

Geotechnical Investigation Proposed Residential Building

230-232 Lisgar Street
Ottawa, Ontario

Prepared for 230 Lisgar Street Inc.

Report PG6401-1 Revision 2 dated October 18, 2023

Table of Contents

	PAGE
1.0 Introduction	1
2.0 Proposed Development.....	1
3.0 Method of Investigation	2
3.1 Field Investigation	2
3.2 Field Survey	3
3.3 Laboratory Review	3
3.4 Analytical testing.....	3
4.0 Observations	4
4.1 Surface Conditions	4
4.2 Subsurface Profile	4
4.3 Groundwater	4
5.0 Discussion	6
5.1 Geotechnical Assessment	6
5.2 Site Grading and Preparation.....	6
5.3 Foundation Design	7
5.4 Design for Earthquakes	11
5.5 Basement Floor Slab.....	11
5.6 Basement Wall	12
5.7 Pavement Structure	13
6.0 Design and Construction Precautions.....	15
6.1 Foundation Drainage and Backfill	15
6.2 Protection of Footings Against Frost Action	16
6.3 Excavation Side Slopes	16
6.4 Pipe Bedding and Backfill	18
6.5 Groundwater Control	19
6.6 Winter Construction.....	20
6.7 Corrosion Potential and Sulphate	20
6.8 Landscaping Considerations.....	20
7.0 Recommendations	21
8.0 Statement of Limitations.....	22

Appendices

- Appendix 1** Soil Profile and Test Data Sheets
 Symbols and Terms
 Analytical Testing Results
- Appendix 2** Figure 1 – Key Plan
 Drawing PG6401-1 - Test Hole Location Plan
- Appendix 3** Relevant Memorandums

1.0 Introduction

Paterson Group (Paterson) was commissioned by 230 Lisgar Street Inc. to conduct a geotechnical investigation for the proposed residential building to be located at 230-232 Lisgar Street, in the City of Ottawa (refer to Figure 1 - Key Plan in Appendix 2 of this report).

The objectives of the geotechnical investigation were to:

- ❑ Determine the subsoil and groundwater conditions at this site by means of test pits.
- ❑ Provide geotechnical recommendations pertaining to the design of the proposed development including construction considerations which may affect the design.

The following report has been prepared specifically and solely for the aforementioned project which is described herein. It contains our findings and includes geotechnical recommendations pertaining to the design and construction of the subject development as they are understood at the time of writing this report.

2.0 Proposed Development

Based on the available drawings, it is understood that the proposed development will consist of a nine-storey apartment building with two (2) levels of underground parking. Associated access lanes, hardscaped areas, and walkways are also anticipated as part of the proposed development. It is anticipated that the proposed development will be municipality serviced.

3.0 Method of Investigation

3.1 Field Investigation

Field Program

The field program for the current geotechnical investigation was carried out on September 22 and 23, 2022. The program consisted of drilling 3 boreholes (BH 1-22, BH 2-22, and BH 3-22) down to a maximum depth of 11.3 m below the existing ground surface. The test hole locations were distributed in a manner to provide general coverage of the subject site. The locations of the test holes are shown on Drawing PG6401-1 - Test Hole Location Plan included in Appendix 2.

The test holes were advanced using a low clearance drill rig and operated by a two-person crew. The drilling procedure consisted of augering to the required depths at the selected locations, and sampling and testing the overburden. All fieldwork was conducted under the full-time supervision of Paterson personnel under the direction of a senior engineer.

Sampling and In Situ Testing

The soil samples were recovered from the auger flights and using a 50 mm diameter split-spoon sampler. The samples were initially classified on site, placed in sealed plastic bags and transported to our laboratory. The depths at which the auger and split-spoon samples were recovered from the boreholes are shown as AU and SS, respectively, on the Soil Profile and Test Data sheets in Appendix 1.

The Standard Penetration Test (SPT) was conducted in conjunction with the recovery of the split-spoon samples. The SPT results are recorded as “N” values on the Soil Profile and Test Data sheets. The “N” value is the number of blows required to drive the split-spoon sampler 300 mm into the soil after a 150 mm initial penetration using a 63.5 kg hammer falling from a height of 760 mm.

The overburden thickness was evaluated by dynamic cone penetration tests (DCPT) at BH 1-22, BH 2-22, and BH 3-22. The DCPT consists of driving a steel drill rod, equipped with a 50 mm diameter cone at the tip, using a 63.5 kg hammer falling from a height of 760 mm. The number of blows required to drive the cone into the soil is recorded for each 300 mm increment.

Undrained shear strength testing was carried out in cohesive soils using a field vane apparatus.

The subsurface conditions observed in the test holes were recorded in detail in the field. The soil profiles are logged on the Soil Profile and Test Data sheets in Appendix 1 of this report.

Groundwater

Flexible polyethylene standpipes were installed in all boreholes to permit monitoring of the groundwater levels subsequent to the completion of the sampling program. The groundwater observations are discussed in subsection 4.3 and presented in the Soil Profile and Test Data Sheets in Appendix 1.

3.2 Field Survey

The test hole locations were selected by Paterson to provide general coverage of the proposed development taking into consideration the existing site features and underground utilities. The test hole locations and ground surface elevation at each test hole location were surveyed by Paterson with respect to a geodetic datum. The location of the test holes and ground surface elevation at each test hole location are presented on Drawing PG6401-1 - Test Hole Location Plan in Appendix 2.

3.3 Laboratory Review

Soil samples recovered from the subject site were visually examined in our laboratory to review the field logs. All representative samples from the current test holes were submitted for moisture content testing.

3.4 Analytical testing

One (1) soil sample from BH 2-22 was submitted for analytical testing to assess the corrosion potential for exposed ferrous metals and the potential of sulphate attacks against subsurface concrete structures. The sample was submitted to determine the concentration of sulphate and chloride, the resistivity and the pH of the sample. The results are presented in Appendix 1 and are discussed further in Section 6.7.

4.0 Observations

4.1 Surface Conditions

The majority of the subject site is currently occupied by two residential dwellings, consisting of two stories each. The asphalt paved ground surface across the subject site is generally flat and at grade with Lisgar Street at approximate geodetic elevation 72 m.

The site is bordered to the north by Lisgar Street, to the east and south by multi-storey residential buildings, and to the west by two-storey residential dwelling.

4.2 Subsurface Profile

Overburden

Generally, the subsurface profile at the test hole locations consists of asphaltic concrete and fill followed by a layer of loose silty sand underlain by a silty clay deposit. The fill consisted of brown silty sand with gravel and crushed stone and clay. The silty clay deposit consisted of a hard to very stiff brown silty clay crust followed by stiff grey silty clay below 3 to 3.7m depth. The silty clay deposit is underlain by compact glacial till consisting of silty sand with gravel, cobbles, boulders with some clay content. Refusal to DCPT was encountered at a depth of 14.25m, 15.85m, and 13.62m in BH 1-22, BH 2-22, and BH 3-22, respectively.

Reference should be made to the Soil Profile and Test Data sheets in Appendix 1 for the details of the soil profile encountered at each test hole location.

Bedrock

Based on available geological mapping, the bedrock in the subject area consists of Paleozoic shale of the Billings Formation with an overburden drift thickness of 10 to 15 m.

4.3 Groundwater

Groundwater levels were measured at the standpipe piezometers installed within the boreholes during the current investigation on September 29, 2022. The measured groundwater levels are presented in Table 1.

Table 1 - Summary of Groundwater Infiltration Level Readings				
Test Hole Number	Ground Surface Elevation (m)	Groundwater Level (m)	Groundwater Elevation (m)	Recording Date
BH 1-22	71.65	Dry	-	September 29, 2022
BH 2-22	71.49	Dry	-	
BH 3-22	71.36	Dry	-	
Note: Ground surface elevations at test hole locations are referenced to a geodetic datum.				

Based on the groundwater observations made during the current investigation, it is anticipated that the long-term groundwater level extends between 5 to 6 m depth below existing grade. It should be noted that perched groundwater conditions may be encountered at the subject site due to the impermeable nature of the silty clay deposit.

Groundwater levels are subject to seasonal fluctuations and therefore may vary at the time of construction. The recorded groundwater levels are noted on the applicable Soil profile and Test Data sheets presented in Appendix 1.

5.0 Discussion

5.1 Geotechnical Assessment

From a geotechnical perspective, the subject site is suitable for the proposed development. The foundation support system required is dependent on the design building loading and depth of foundation. Several foundation support options are listed below and discussed in the following sub- sections:

- Conventional or raft footing placed on undisturbed stiff brown silty clay, or compact glacial till bearing surface.
- Conventional footings placed on vertical, zero entry lean concrete filled trenches extended to the underlying compact glacial till bearing surface.
- Driven piles extending down to bedrock bearing surface.

Where loose glacial till may be encountered below the footprint of the proposed footings, provisions should be made to proof roll the soil subgrade using heavy vibratory compaction equipment followed by field density testing prior to placing the foundations.

Given the presence of a silty clay deposit, a permissible grade raise restriction is required for the proposed development. The permissible grade raise recommendations are further discussed in Subsection 5.3.

Due to the depth of excavation, a temporary shoring system will be required to complete the excavation. The proposed shoring system will have to take into consideration support of the existing structure due to the close proximity of the neighboring buildings and road.

The above and other considerations are further discussed in the following sections.

5.2 Site Grading and Preparation

Stripping Depth

Topsoil, asphalt, and deleterious fill, such as those containing organic materials or construction debris/remnants, should be stripped from under any buildings, paved areas, pipe bedding and other settlement sensitive structures. Under paved areas, existing construction remnants, such as foundation walls, pipe ducts, etc., should be excavated to a minimum depth of 1 m below final grade.

It is expected that the proposed underground parking levels will extend to a depth well within the native soils. Therefore, all surface soils will be removed as part of the excavation for the proposed structure.

Fill Placement

Engineered fill placed for grading beneath the building footprints, where required, should consist of clean imported granular fill, such as Ontario Provincial Standard Specifications (OPSS) Granular A or Granular B Type II. This material should be tested and approved prior to delivery to the site. The fill should be placed in maximum 300 mm thick loose lifts and compacted by suitable compaction equipment. Fill placed beneath the buildings and paved areas should be compacted to at least 98% of the material's standard Proctor maximum dry density (SPMDD).

Non-specified existing fill along with site-excavated soil can be placed as general landscaping fill where settlement of the ground surface is of minor concern. The backfill materials should be spread in thin lifts and at a minimum compacted by the tracks of the spreading equipment to minimize voids. If the non-specified backfill is to be placed to increase the subgrade level for areas to be paved, the fill should be compacted in maximum 300 mm lifts and compacted to 95% of the material's SPMDD. Non-specified existing fill and site-excavated soils are not suitable for placement as backfill against foundation walls unless a composite drainage blanket connected to a perimeter drainage system is provided.

Protective Mud Slab

If a raft slab is selected to support the proposed building, it is recommended that lean concrete mud slab be placed on the undisturbed subgrade surface to protect it from disturbance due to worker traffic. A 75 mm thick lean concrete mud slab (minimum 15 MPa 28-day compressive strength) is recommended to be poured over the undisturbed subgrade surface once exposed.

5.3 Foundation Design

Several foundation design options are available for the proposed building depending on the design loading and foundation depth. The following foundation options are recommended.

Conventional Shallow Foundation

Strip footings, up to 2m wide, and pad footings, up to 5m wide, placed directly on undisturbed, stiff brown silty clay, or compact glacial till can be designed using a bearing resistance value at SLS of **150 kPa** and a factored bearing resistance value at ULS of **225 kPa**. A geotechnical resistance factor of 0.5 was applied to the bearing resistance value at ULS.

Where loose glacial till is encountered below the foundation, provisions should be made to proof-rolling the soil subgrade using heavy vibratory compaction equipment prior to placing the foundations. Any soft areas should be removed and backfilled with OPSS Granular A or Granular B Type II.

An undisturbed soil bearing surface consists of a surface from which all topsoil and deleterious materials, such as loose, frozen or disturbed soil, whether in situ or not, have been removed, in the dry, prior to the placement of concrete for footings.

Footings bearing on an undisturbed soil bearing surface and designed using the bearing resistance values provided herein, will be subjected to potential post-construction total and differential settlements of 25 and 20 mm, respectively.

Lean Concrete Filled Trenches

Consideration should be given to excavating vertical trenches to the compact to dense glacial till bearing surface and backfilling with lean concrete (20 MPa 28-day compressive strength). Typically, the excavation sidewalls will be used as the form to support the concrete. The additional width of the concrete poured against an undisturbed trench sidewall will suffice in providing a direct transfer of the footing load to the underlying bedrock.

The effectiveness of this operation will depend on the ability of maintaining vertical trenches until the lean concrete can be poured. It is suggested that once the bottom of the excavation is exposed, an assessment should be completed to determine the water infiltration and stability of the excavation sidewalls extending to the bedrock surface.

The trench excavation should be at least 300 mm wider than all sides of the footing at the base of the excavation. The excavation bottom should be relatively clean using the hydraulic shovel only (workers will not be permitted in the excavation below a 1.5 m depth). Once approved by the geotechnical engineer, lean concrete can be poured up to the proposed founding elevation.

Lateral Support

The bearing medium under footing-supported structures is required to be provided with adequate lateral support with respect to excavations and different foundation levels. Adequate lateral support is provided to an in-situ soil bearing medium when a plane extending down and out from the bottom edge of the footing at a minimum of 1.5H:1V, passes only through in situ soil or engineered fill of the same or higher capacity as the soil.

Raft Foundation

Where the anticipated loads exceed the allowable bearing resistance values provided above, considerations can be given to placing the proposed building on a raft foundation placed on the undisturbed stiff silty clay and or compact glacial till bearing surface.

For design purposes, it was assumed that the base of a raft foundation for the proposed building would be located at 6 to 7 m depth with two anticipated underground levels. The bearing medium will consist of a stiff grey silty clay or compact glacial till which is susceptible to disturbance under construction traffic. The bearing surface should be protected to prevent disturbance as described above.

The amount of settlement of the raft slab will be dependent on the sustained raft contact pressure. The bearing resistance value at SLS (contact pressure) of **200 kPa** will be considered acceptable. The loading conditions for the contact pressure are based on sustained loads, that are generally taken to be 100% Dead Load and 50% Live Load. The contact pressure provided considers the stress relief associated with the soil removal required for the proposed building. The factored bearing resistance value at ULS can be taken as **300 kPa**. A geotechnical resistance factor of 0.5 was applied to the bearing resistance value at ULS.

The modulus of subgrade reaction was calculated to be **8.0 MPa/m** for a contact pressure of **200 kPa**. The design of the raft foundation is required to consider the relative stiffness of the reinforced concrete slab and the supporting bearing medium.

Based on the following assumptions for the raft foundation, the proposed building can be designed with the above parameters and a potential total and differential settlement of 25 and 20 mm, respectively.

Deep Foundation - End Bearing Piles

A deep foundation method, such as end bearing piles, can be considered for the proposed structure. Concrete filled steel pipe piles driven to refusal on a bedrock surface are a typical deep foundation option in Ottawa.

Applicable pile resistance at SLS values and factored pile resistance at ULS values are provided in Table 2. Additional resistance values can be provided if available pile sizes vary from those detailed in Table 5.

A resistance factor of 0.4 has been incorporated into the factored ULS values. Note that these are all geotechnical axial resistance values.

The geotechnical pile resistance values were estimated calculating the Hiley dynamic formula. The piles should be confirmed during pile installation with a program of dynamic monitoring. For this project, the dynamic monitoring of four piles is recommended. This is considered to be the minimum monitoring program, as the piles under shear walls may be required to be driven using the maximum recommended driving energy to achieve the greatest factored resistance at ULS values. Re-striking of all piles will also be required after at least 48 hours have elapsed since initial driving.

Pile Outside Diameter (mm)	Pile Wall Thickness (mm)	Geotechnical Axial Resistance		Final Set (blows/ 25 mm)	Transferred Hammer Energy (kJ)
		SLS (kN)	Factored at ULS (kN)		
245	10	975	1460	10	36
245	12	1100	1650	10	42
245	13	1175	1760	10	45

Permissible Grade Raise

Due to the presence of the silty clay deposit, a permissible grade raise restriction of **2.0 m** is recommended for grading at the subject site. If higher than permissible grade raises are required, preloading with or without a surcharge, lightweight fill, and/or other measures should be investigated to reduce the risks of unacceptable long-term post construction total and differential settlements.

5.4 Design for Earthquakes

The site class for seismic site response can be taken as **Class D** for the shallow foundations at the subject site. The soils underlying the subject site are not susceptible to liquefaction. Reference should be made to the latest revision of the 2012 Ontario Building Code for a full discussion of the earthquake design requirements.

5.5 Basement Floor Slab

Due to the anticipated level of excavation, it is anticipated that all topsoil and fill will be removed. For the proposed basement floor slab, the bearing medium will consist of stiff grey silty clay or compact glacial till. The undisturbed native soil surface, approved by the Paterson personnel at the time of construction, is considered to be an acceptable subgrade surface on which to commence backfilling for the floor slab construction.

It is expected that the basement area for the proposed building will be mostly parking, and the recommended pavement structures noted in Section 5.7 will be applicable. However, if storage or other uses of the lower level will involve the construction of a concrete floor slab, the upper 200 mm of sub-slab fill is recommended to consist of 19 mm clear crushed stone.

Where loose glacial till is encountered below the slab, provisions should be made to proof-rolling the soil subgrade using heavy vibratory compaction equipment prior to placing any fill. Any soft areas in the basement slab/floor slab subgrade should be removed and backfilled with appropriate backfill material prior to placing fill.

OPSS Granular B Types I or II, with a maximum particle size of 50 mm, are recommended for backfilling below the floor slab (outside the zones of influence of the footings). It is recommended that the upper 200 mm of sub-slab fill consists of OPSS Granular A crushed stone. All backfill material within the footprint of the proposed building should be placed in maximum 300 mm thick loose layers and compacted to a minimum of 98% of the SPMDD.

In consideration of the groundwater conditions at the site, a sub-slab drainage system, consisting of lines of perforated drainage pipe subdrains connected to a positive outlet, such as the sump pump pit, should be provided in the subfloor fill under the lower basement floor. This is discussed further in Subsection 6.1.

5.6 Basement Wall

There are several combinations of backfill materials and retained soils that could be applicable for the basement walls of the subject structure. However, the conditions can be well-represented by assuming the retained soil consists of a material with an angle of internal friction of 30 degrees and a drained unit weight of 20 kN/m³.

However, undrained conditions are anticipated (i.e. below the groundwater level). Therefore, the applicable effective (undrained) unit weight of the retained soil can be taken as 13 kN/m³, where applicable. A hydrostatic pressure should be added to the total static earth pressure when using the effective unit weight.

Lateral Earth Pressures

The static horizontal earth pressure (p_o) can be calculated using a triangular earth pressure distribution equal to $K_o \cdot \gamma \cdot H$ where:

K_o = at-rest earth pressure coefficient of the applicable retained soil (0.5)

γ = unit weight of fill of the applicable retained soil (kN/m³)

H = height of the wall (m)

An additional pressure having a magnitude equal to $K_o \cdot q$ and acting on the entire height of the wall should be added to the above diagram for any surcharge loading, q (kPa), that may be placed at ground surface adjacent to the wall. The surcharge pressure will only be applicable for static analyses and should not be used in conjunction with the seismic loading case.

Actual earth pressures could be higher than the “at-rest” case if care is not exercised during the compaction of the backfill materials to maintain a minimum separation of 0.3 m from the walls with the compaction equipment.

Seismic Earth Pressures

The total seismic force (P_{AE}) includes both the earth force component (P_o) and the seismic component (ΔP_{AE}). The seismic earth force (ΔP_{AE}) can be calculated using $0.375 \cdot a_c \cdot \gamma \cdot H^2/g$ where:

$a_c = (1.45 - a_{max}/g)a_{max}$

γ = unit weight of fill of the applicable retained soil (kN/m³)

H = height of the wall (m)

g = gravity, 9.81 m/s²

The peak ground acceleration, (a_{max}), for the site area is 0.32 g according to OBC 2012. Note that the vertical seismic coefficient is assumed to be zero.

The earth force component (P_o) under seismic conditions can be calculated using $P_o = 0.5 K_o \gamma H^2$, where $K_o = 0.5$ for the soil conditions noted above.

The total earth force (P_{AE}) is considered to act at a height, h (m), from the base of the wall, where:

$$h = \{P_o \cdot (H/3) + \Delta P_{AE} \cdot (0.6 \cdot H)\} / P_{AE}$$

The earth forces calculated are unfactored. For the ULS case, the earth loads should be factored as live loads, as per OBC 2012.

5.7 Pavement Structure

For design purposes, it is recommended that the rigid pavement structure for the lower underground parking level of the proposed building consist of Category C2, 32 MPa concrete at 28 days with air entrainment of 5 to 8%. The recommended rigid pavement structure is further presented in Table 3 below.

Table 3 - Recommended Rigid Pavement Structure - Lower Parking Level	
Thickness (mm)	Material Description
125	Exposure Class C2 - 32 MPa Concrete (5 to 8% Air Entrainment)
300	BASE - OPSS Granular A Crushed Stone
SUBGRADE - Existing imported fill, or OPSS Granular B Type I or II material placed over in situ soil or bedrock.	

The pavement structures presented in Tables 4 and 5 should be used for car only parking areas and heavy loading parking areas:

Table 4 - Recommended Pavement Structure - Car-Only Parking Areas	
Thickness (mm)	Material Description
50	Wear Course - HL-3 or Superpave 12.5 Asphaltic Concrete
150	BASE - OPSS Granular A Crushed Stone
300	SUBBASE - OPSS Granular B Type II
SUBGRADE - Either in situ soils, bedrock or OPSS Granular B Type I or II material placed over in situ soil	

Table 5 - Recommended Pavement Structure – Heavy-Truck Traffic and Loading Areas	
Thickness (mm)	Material Description
40	Wear Course - HL-3 or Superpave 12.5 Asphaltic Concrete
50	Binder Course - HL-8 or Superpave 19.0 Asphaltic Concrete
150	BASE - OPSS Granular A Crushed Stone
450	SUBBASE - OPSS Granular B Type II
SUBGRADE - Either in situ soils, bedrock or OPSS Granular B Type I or II material placed over in situ soil	

Minimum Performance Graded (PG) 58-34 asphalt cement should be used for this project.

If soft spots develop in the subgrade during compaction or due to construction traffic, the affected areas should be excavated and replaced with OPSS Granular B Type I or II material. Weak subgrade conditions may be experienced over service trench fill materials. This may require the use of a geotextile, thicker subbase or other measures that can be recommended at the time of construction as part of the field observation program.

The pavement granular base and subbase should be placed in maximum 300 mm thick lifts and compacted to a minimum of 100% of the material's SPMDD using suitable compaction equipment.

Pavement Structure Drainage

Satisfactory performance of the pavement structure is largely dependent on keeping the contact zone between the subgrade material and the base stone in a dry condition. Failure to provide adequate drainage under conditions of heavy wheel loading can result in the fine subgrade soil being pumped into the voids in the stone subbase, thereby reducing its load carrying capacity.

Due to the impervious nature of the subgrade materials consideration should be given to installing subdrains at each catch basin during the pavement construction. These drains should be at least 3 m long and extend in four orthogonal directions or longitudinally when placed along a curb. The subdrain inverts should be approximately 300 mm below subgrade level. The subgrade surface should be shaped to promote water flow to the drainage lines.

6.0 Design and Construction Precautions

6.1 Foundation Drainage and Backfill

Foundation Drainage

A perimeter foundation drainage system is recommended for each proposed structure. The system should consist of a 150 mm diameter, geotextile-wrapped, perforated and corrugated plastic pipe which is surrounded on all sides by 150 mm of 19 mm clear crushed stone which is placed at the footing level around the exterior perimeter of the structure. The pipe should have a positive outlet, such as a gravity connection to the storm sewer.

It is anticipated that the long term groundwater level will be located deeper than the design founding level. However, perched water conditions may be encountered due to the impermeable nature of the silty clay deposit. The groundwater conditions shall be reassessed during construction to determine whether a waterproofing membrane will be required for the proposed foundation walls.

It is important to note that the building's mechanical pits (sump pit and elevator pit) along with the podium deck be considered for waterproofing. A detail can be provided by Paterson once the design drawings are available for the elevator and sump pits.

Foundation Backfill

Backfill against the exterior sides of the foundation walls should consist of free-draining non frost susceptible granular materials. The greater part of the site excavated materials will be frost susceptible and, as such, are not recommended for re-use as backfill against the foundation walls, unless used in conjunction with a drainage geocomposite, such as Delta Drain 6000, connected to the perimeter foundation drainage system. Imported granular materials, such as clean sand or OPSS Granular B Type I granular material, should otherwise be used for this purpose. A waterproofing system should be provided for any elevator pits (pit bottom and walls).

Under-slab Drainage

Under-slab drainage is recommended to control water infiltration for the basement area. For preliminary design purposes, we recommend that 150 mm diameter perforated PVC pipes be placed at approximate 6 m spacing. The spacing of the under-slab drainage system should be confirmed at the completion time of the excavation when water infiltration can be better assessed.

Adverse Effects of Dewatering on Adjacent Properties

Due to low permeability of the subsoils profile, any minor dewatering will be considered temporary and limited to the local area of the proposed building during the construction period. Therefore, adverse effects to the surrounding buildings or properties are not expected with respect to any groundwater lowering

6.2 Protection of Footings Against Frost Action

Perimeter footings of heated structures are recommended to be insulated against the deleterious effects of frost action. A minimum 1.5 m thick of soil cover alone, or a minimum 0.6 m thick of soil cover in conjunction with adequate foundation insulation, should be provided in this regard.

Exterior unheated footings, such as those for isolated exterior piers, are more prone to deleterious movement associated with frost action than the exterior walls of the heated structure and require additional protection, such as soil cover of 2.1 m or an equivalent combination of soil cover and foundation insulation.

Unheated structures, such as the access ramp wall footings, may be required to be insulated against the deleterious effect of frost action. A minimum of 2.1 m of soil cover alone, or a minimum of 0.6 m of soil cover, in conjunction with foundation insulation, should be provided for the ramp wall. This can be provided by Paterson upon reviewing the design drawings completed by the project's architect.

6.3 Excavation Side Slopes

The side slopes of excavations in the overburden should be either cut back at acceptable slopes or should be retained by shoring systems from the start of the excavation until the structure is backfilled. It is expected that sufficient room will be available for the greater part of the excavation to be undertaken by open-cut methods (i.e. unsupported excavations).

The excavation side slopes above the groundwater level extending to a maximum depth of 3 m should be cut back at 1H:1V or flatter. The flatter slope is required for excavation below groundwater level. Excavations below the groundwater level should be cut back at a maximum slope of 1.5H:1V. Where such side slopes are not permissible or practical, temporary shoring should be installed. The subsoil at this site is considered to be mainly a Type 2 and 3 soil according to the Occupational Health and Safety Act and Regulations for Construction Projects.

Excavated soil should not be stockpiled directly at the top of excavations and heavy equipment should be kept away from the excavation sides.

Slopes in excess of 3 m in height should be periodically inspected by the geotechnical consultant in order to detect if the slopes are exhibiting signs of distress.

It is recommended that a trench box be used at all times to protect personnel working in trenches with steep or vertical sides. It is expected that services will be installed by “cut and cover” methods and excavations will not be left open for extended periods of time.

Temporary Shoring

Temporary shoring may be required for the overburden soil to complete the required excavations where insufficient room is available for open cut methods. The shoring requirements designed by a structural engineer specializing in those works will depend on the depth of the excavation, the proximity of the adjacent structures and the elevation of the adjacent building foundations and underground services. The design and implementation of these temporary systems will be the responsibility of the excavation contractor and their design team. Inspections and approval of the temporary system will also be the responsibility of the designer.

Geotechnical information provided below is to assist the designer in completing a suitable and safe shoring system. The designer should take into account the impact of a significant precipitation event and designate design measures to ensure that a precipitation will not negatively impact the shoring system or soils supported by the system.

Any changes to the approved shoring design system should be reported immediately to the owner’s structural design prior to implementation.

The temporary shoring system could consist of a soldier pile and lagging system. Any additional loading due to street traffic, construction equipment, adjacent structures and facilities, etc., should be included to the earth pressures described below. This system could be cantilevered, anchored or braced. The shoring system is recommended to be adequately supported to resist toe failure, if required, by means of extending the piles into the bedrock through pre-augered holes, if a soldier pile and lagging system is the preferred method.

The earth pressures acting on the temporary shoring system may be calculated with the following parameters.

Table 6 – Soils Parameter for Shoring System Design	
Parameters	Values
Active Earth Pressure Coefficient (K_a)	0.33
Passive Earth Pressure Coefficient (K_p)	3
At-Rest Earth Pressure Coefficient (K_o)	0.5
Unit Weight (γ), kN/m ³	20
Submerged Unit Weight (γ), kN/m ³	13

The active earth pressure should be calculated where wall movements are permissible while the at-rest pressure should be calculated if no movement is permissible. The dry unit weight should be calculated above the groundwater level while the effective unit weight should be calculated below the groundwater level.

The hydrostatic groundwater pressure should be included to the earth pressure distribution wherever the effective unit weights are calculated for earth pressures. If the groundwater level is lowered, the dry unit weight for the soil should be calculated full weight, with no hydrostatic groundwater pressure component.

For design purposes, the minimum factor of safety of 1.5 should be calculated.

6.4 Pipe Bedding and Backfill

Bedding and backfill materials should be in accordance with the most recent Material Specifications & Standard Detail Drawings of the OPSD.

A minimum of 150 mm of OPSS Granular A should be placed for bedding for sewer or water pipes when placed on a soil subgrade. If the bedding is placed on bedrock, the thickness of the bedding should be increased to 300 mm for sewer pipes. The bedding should extend to the spring line of the pipe. Cover material, from the spring line to a minimum of 300 mm above the obvert of the pipe, should consist of OPSS Granular A (concrete or PSM PVC pipes) or sand (concrete pipe). The bedding and cover materials should be placed in maximum 225 mm thick lifts and compacted to 95% of the SPMDD.

It should generally be possible to re-use the site materials above the cover material if the operations are carried out in dry weather conditions.

Where hard surface areas are considered above the trench backfill, the trench backfill material within the frost zone (about 1.5 m below finished grade) and above the cover material should match the soils exposed at the trench walls to minimize differential frost heaving. The trench backfill should be placed in maximum 225 mm thick loose lifts and compacted to a minimum of 95% of the material's SPMDD.

6.5 Groundwater Control

Groundwater Control for Building Construction

Based on our observations, it is anticipated that groundwater infiltration into the excavations should be low to moderate and controllable using open sumps. The contractor should be prepared to direct water away from all bearing surfaces and subgrades, regardless of the source, to prevent disturbance to the founding medium. For excavation within the glacial till and below the long term groundwater level, higher infiltration rates are anticipated.

Groundwater Control for Building Construction

A temporary Ministry of the Environment, Conservation and Parks (MECP) permit to take water (PTTW) may be required if more than 400,000 L/day of ground and/or surface water is to be pumped during the construction phase. A minimum 4 to 5 months should be allowed for completion of the PTTW application and issuance of the permit by the MECP.

For typical ground or surface water volumes being pumped during the construction phase, typically between 50,000 to 400,000 L/day, it is required to register on the Environmental Activity and Sector Registry (EASR). A minimum of two to four weeks should be allotted for completion of the EASR registration and the Water Taking and Discharge Plan to be prepared by a Qualified Person as stipulated under O.Reg. 63/16. If a project qualifies for a PTTW based upon anticipated conditions, an EASR will not be allowed as a temporary dewatering measure while awaiting the MECP review of the PTTW application.

Impacts to Neighbouring Properties

It is understood that 2 levels of underground parking are planned for the proposed building. Any groundwater encountered along the building's perimeter or under-slab drainage system will be directed to the proposed building's cistern/sump pit. Provided the proposed groundwater infiltration control system is properly implemented and approved by the geotechnical consultant at the time of construction, long-term groundwater lowering is anticipated to be negligible for the area. Therefore, no adverse effects to neighbouring properties are expected.

6.6 Winter Construction

Precautions must be taken if winter construction is considered for this project. The subsoil conditions at this site consist of frost susceptible materials. In the presence of water and freezing conditions, ice could form within the soil mass. Heaving and settlement upon thawing could occur.

In the event of construction during below zero temperatures, the founding stratum should be protected from freezing temperatures by the use of straw, propane heaters and tarpaulins or other suitable means. In this regard, the base of the excavations should be insulated from sub-zero temperatures immediately upon exposure and until such time as heat is adequately supplied to the building and the footings are protected with sufficient soil cover to prevent freezing at founding level.

Trench excavations and pavement construction are also difficult activities to complete during freezing conditions without introducing frost into the subgrade or in the excavation walls and bottoms. Precautions should be taken if such activities are to be carried out during freezing conditions.

6.7 Corrosion Potential and Sulphate

One (1) sample from BH 2-22 was submitted for testing. The analytical test results of the soil sample indicate that the sulphate content is less than 0.1%. This result is indicative that Type 10 Portland cement (normal cement) would be appropriate for this site. The chloride content and the pH of the sample indicate they are not significant factors in creating a corrosive environment for exposed ferrous metals at this site, whereas the resistivity is indicative of a non-aggressive to slightly aggressive environment.

6.8 Landscaping Considerations

Tree Planting Restrictions

Due to the anticipated depth of the underground levels and the overall proposed project, the City of Ottawa tree planting restrictions are not applicable for the subject site.

7.0 Recommendations

It is a requirement for the foundation design data provided herein to be applicable that the following material testing and observation program be performed by the geotechnical consultant:

- Review of the grading and site servicing plans from a geotechnical perspective.
- Review of the proposed excavation activities
- Reassess the groundwater conditions once the final excavation level is reached to determine waterproofing requirements.
- Once structural and architectural drawings are available, it is recommended that Paterson provide a damp-proofing, waterproofing and drainage plan for the subject building.
- Periodic inspections of the damp-proofing of the foundation walls and waterproofing of the mechanical pits from a geotechnical perspective.
- Observation of all bearing surfaces prior to the placement of concrete.
- Sampling and testing of the concrete and fill materials.
- Observation of all subgrades prior to backfilling.
- Field density tests to determine the level of compaction achieved.
- Sampling and testing of the bituminous concrete including mix design reviews.

A report confirming that these works have been conducted in general accordance with our recommendations could be issued upon the completion of a satisfactory inspection program by the geotechnical consultant.

All excess soils, with the exception of engineered crushed stone fill, generated by construction activities that will be transported on-site or off-site should be handled as per *Ontario Regulation 406/19: On-Site and Excess Soil Management*.

8.0 Statement of Limitations

The recommendations provided are in accordance with the present understanding of the project. Paterson requests permission to review the recommendations when the drawings and specifications are completed.

A soils investigation is a limited sampling of a site. Should any conditions at the site be encountered which differ from those at the test locations, Paterson requests immediate notification to permit reassessment of our recommendations.

The recommendations provided herein should only be used by the design professionals associated with this project. They are not intended for contractors bidding on or undertaking the work. The latter should evaluate the factual information provided in this report and determine the suitability and completeness for their intended construction schedule and methods. Additional testing may be required for their purposes.

The present report applies only to the project described in this document. Use of this report for purposes other than those described herein or by person(s) other than 230 Lisgar Street Inc. or their agents is not authorized without review by Paterson for the applicability of our recommendations to the alternative use of the report.

Paterson Group Inc.



Maha Saleh, M.A.Sc., P.Eng.



Faisal I. Abou-Seido, P. Eng.

Report Distribution:

- 230 Lisgar Street Inc. (email copy)
- Paterson Group

APPENDIX 1

SOIL PROFILE AND TEST DATA SHEETS

SYMBOLS AND TERMS

ANALYTICAL TESTING RESULTS

DATUM Geodetic

REMARKS

BORINGS BY CME-55 Low Clearance Drill

DATE September 22, 2022

FILE NO.
PG6401

HOLE NO.
BH 1-22

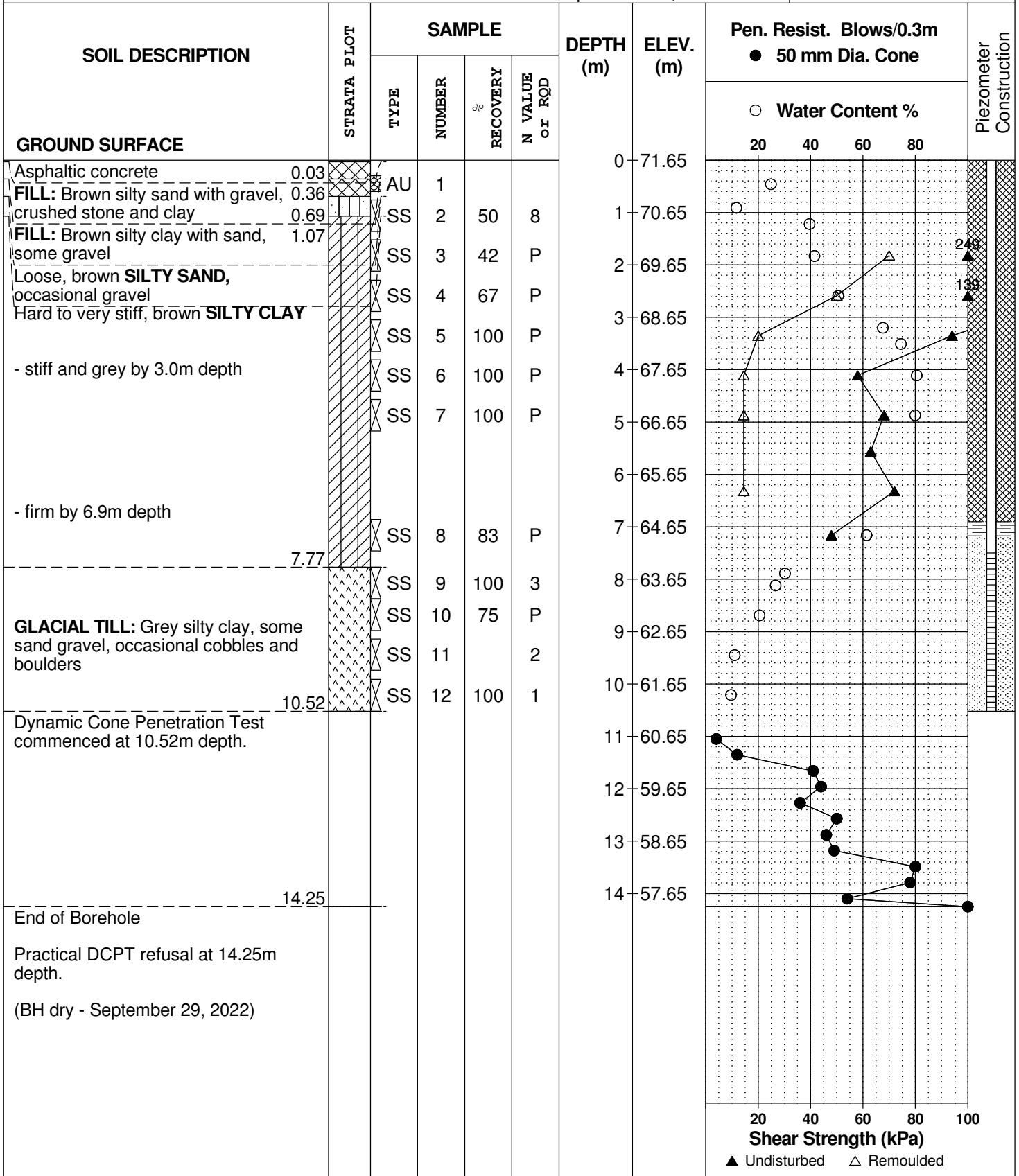

DATUM Geodetic

REMARKS

BORINGS BY CME-55 Low Clearance Drill

DATE September 22, 2022

FILE NO.
PG6401

HOLE NO.
BH 2-22

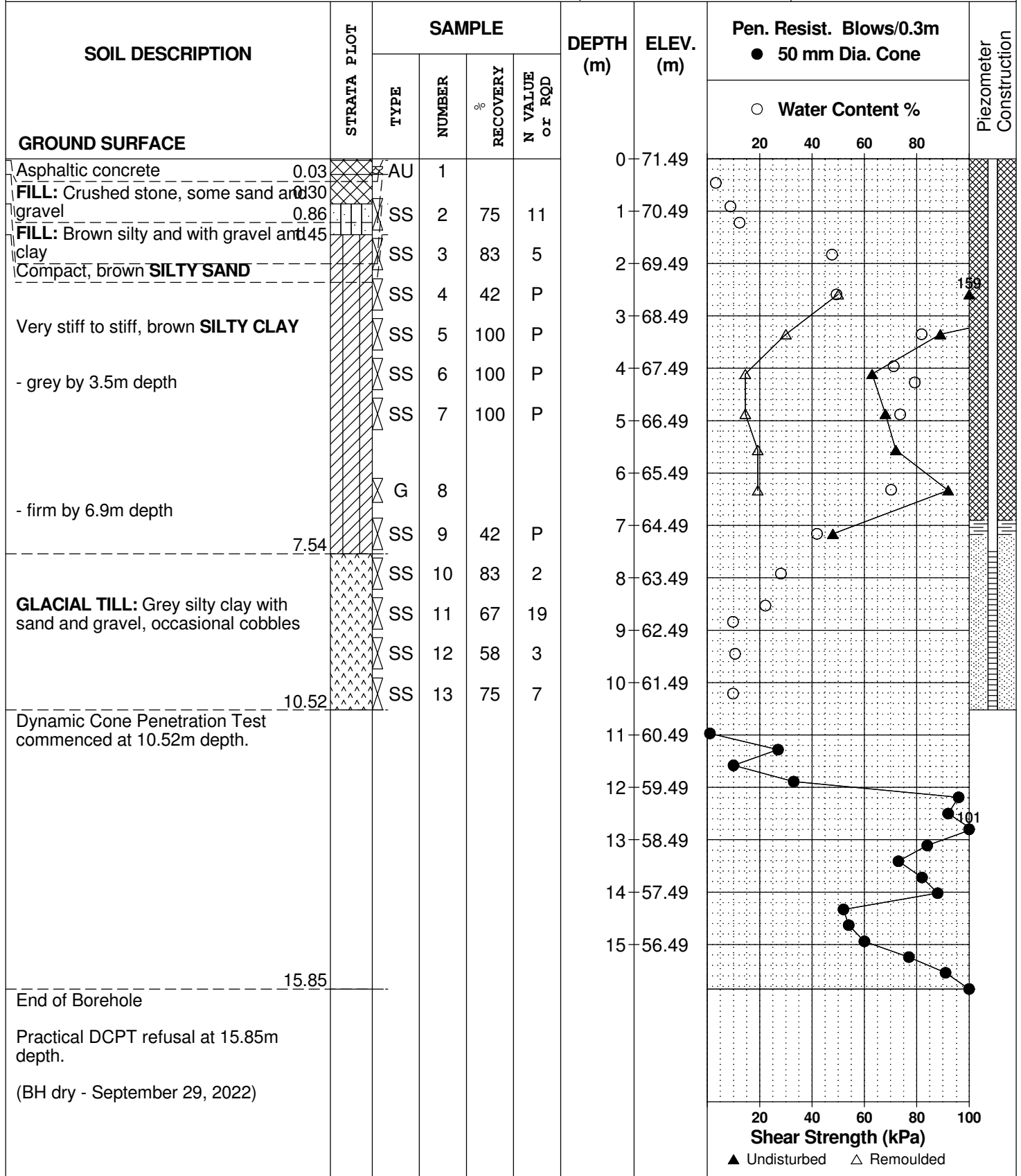

DATUM Geodetic

REMARKS

BORINGS BY CME-55 Low Clearance Drill

DATE September 23, 2022

FILE NO.
PG6401

HOLE NO.
BH 3-22

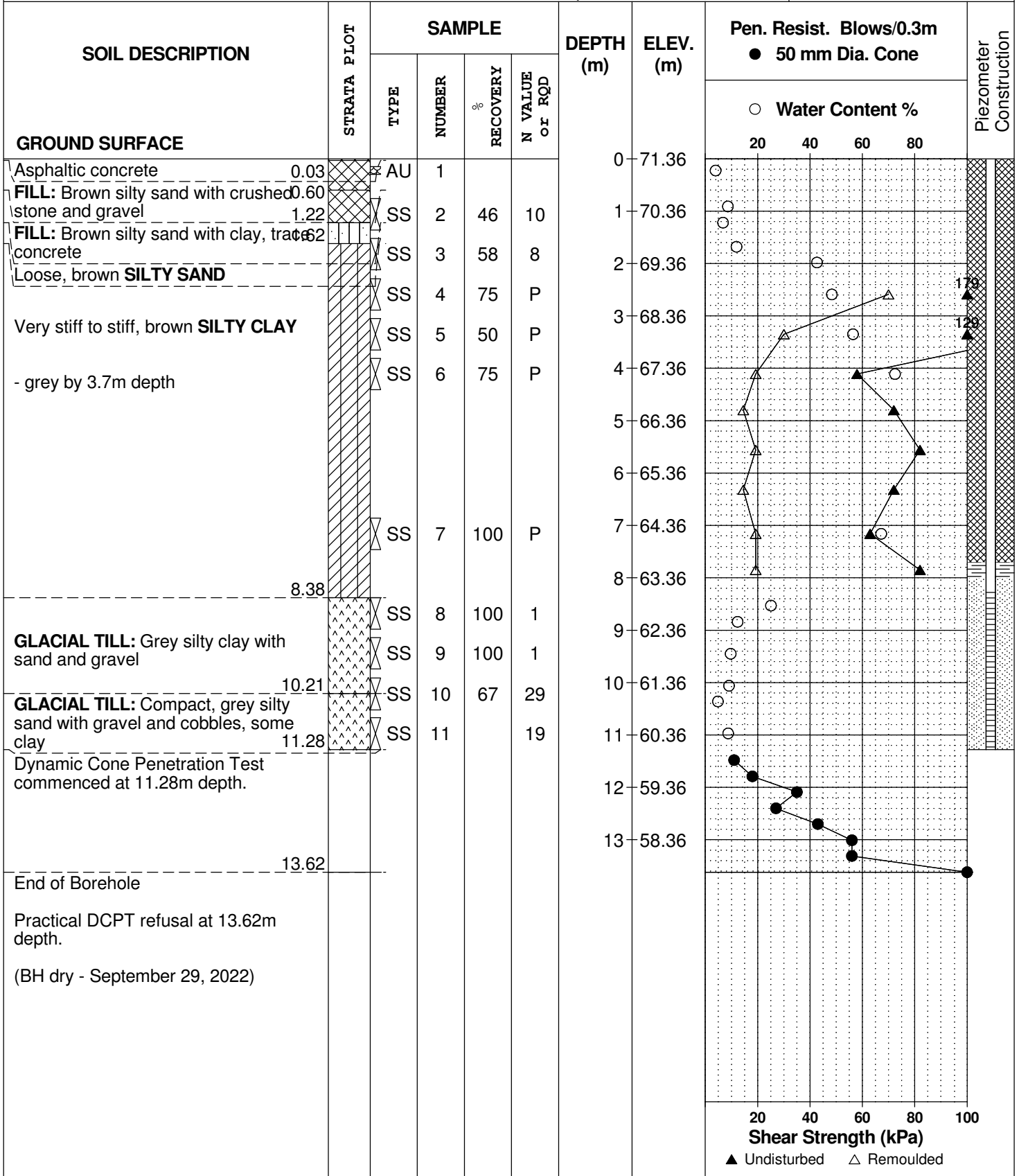

SYMBOLS AND TERMS

SOIL DESCRIPTION

Behavioural properties, such as structure and strength, take precedence over particle gradation in describing soils. Terminology describing soil structure are as follows:

Desiccated	-	having visible signs of weathering by oxidation of clay minerals, shrinkage cracks, etc.
Fissured	-	having cracks, and hence a blocky structure.
Varved	-	composed of regular alternating layers of silt and clay.
Stratified	-	composed of alternating layers of different soil types, e.g. silt and sand or silt and clay.
Well-Graded	-	Having wide range in grain sizes and substantial amounts of all intermediate particle sizes (see Grain Size Distribution).
Uniformly-Graded	-	Predominantly of one grain size (see Grain Size Distribution).

The standard terminology to describe the strength of cohesionless soils is the relative density, usually inferred from the results of the Standard Penetration Test (SPT) 'N' value. The SPT N value is the number of blows of a 63.5 kg hammer, falling 760 mm, required to drive a 51 mm O.D. split spoon sampler 300 mm into the soil after an initial penetration of 150 mm.

Relative Density	'N' Value	Relative Density %
Very Loose	<4	<15
Loose	4-10	15-35
Compact	10-30	35-65
Dense	30-50	65-85
Very Dense	>50	>85

The standard terminology to describe the strength of cohesive soils is the consistency, which is based on the undisturbed undrained shear strength as measured by the in situ or laboratory vane tests, penetrometer tests, unconfined compression tests, or occasionally by Standard Penetration Tests.

Consistency	Undrained Shear Strength (kPa)	'N' Value
Very Soft	<12	<2
Soft	12-25	2-4
Firm	25-50	4-8
Stiff	50-100	8-15
Very Stiff	100-200	15-30
Hard	>200	>30

SYMBOLS AND TERMS (continued)

SOIL DESCRIPTION (continued)

Cohesive soils can also be classified according to their "sensitivity". The sensitivity is the ratio between the undisturbed undrained shear strength and the remoulded undrained shear strength of the soil.

Terminology used for describing soil strata based upon texture, or the proportion of individual particle sizes present is provided on the Textural Soil Classification Chart at the end of this information package.

ROCK DESCRIPTION

The structural description of the bedrock mass is based on the Rock Quality Designation (RQD).

The RQD classification is based on a modified core recovery percentage in which all pieces of sound core over 100 mm long are counted as recovery. The smaller pieces are considered to be a result of closely-spaced discontinuities (resulting from shearing, jointing, faulting, or weathering) in the rock mass and are not counted. RQD is ideally determined from NXL size core. However, it can be used on smaller core sizes, such as BX, if the bulk of the fractures caused by drilling stresses (called "mechanical breaks") are easily distinguishable from the normal in situ fractures.

RQD %	ROCK QUALITY
90-100	Excellent, intact, very sound
75-90	Good, massive, moderately jointed or sound
50-75	Fair, blocky and seamy, fractured
25-50	Poor, shattered and very seamy or blocky, severely fractured
0-25	Very poor, crushed, very severely fractured

SAMPLE TYPES

SS	-	Split spoon sample (obtained in conjunction with the performing of the Standard Penetration Test (SPT))
TW	-	Thin wall tube or Shelby tube
PS	-	Piston sample
AU	-	Auger sample or bulk sample
WS	-	Wash sample
RC	-	Rock core sample (Core bit size AXT, BXL, etc.). Rock core samples are obtained with the use of standard diamond drilling bits.

SYMBOLS AND TERMS (continued)

GRAIN SIZE DISTRIBUTION

MC%	-	Natural moisture content or water content of sample, %
LL	-	Liquid Limit, % (water content above which soil behaves as a liquid)
PL	-	Plastic limit, % (water content above which soil behaves plastically)
PI	-	Plasticity index, % (difference between LL and PL)
Dxx	-	Grain size which xx% of the soil, by weight, is of finer grain sizes These grain size descriptions are not used below 0.075 mm grain size
D10	-	Grain size at which 10% of the soil is finer (effective grain size)
D60	-	Grain size at which 60% of the soil is finer
Cc	-	Concavity coefficient = $(D_{30})^2 / (D_{10} \times D_{60})$
Cu	-	Uniformity coefficient = D_{60} / D_{10}

Cc and Cu are used to assess the grading of sands and gravels:

Well-graded gravels have: $1 < Cc < 3$ and $Cu > 4$

Well-graded sands have: $1 < Cc < 3$ and $Cu > 6$

Sands and gravels not meeting the above requirements are poorly-graded or uniformly-graded.

Cc and Cu are not applicable for the description of soils with more than 10% silt and clay (more than 10% finer than 0.075 mm or the #200 sieve)

CONSOLIDATION TEST

p'_o	-	Present effective overburden pressure at sample depth
p'_c	-	Preconsolidation pressure of (maximum past pressure on) sample
Ccr	-	Recompression index (in effect at pressures below p'_c)
Cc	-	Compression index (in effect at pressures above p'_c)
OC Ratio		Overconsolidation ratio = p'_c / p'_o
Void Ratio		Initial sample void ratio = volume of voids / volume of solids
Wo	-	Initial water content (at start of consolidation test)

PERMEABILITY TEST

k	-	Coefficient of permeability or hydraulic conductivity is a measure of the ability of water to flow through the sample. The value of k is measured at a specified unit weight for (remoulded) cohesionless soil samples, because its value will vary with the unit weight or density of the sample during the test.
---	---	--

SYMBOLS AND TERMS (continued)

STRATA PLOT



Topsoil

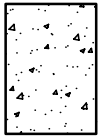

Asphalt

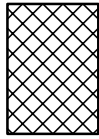

Fill



Peat

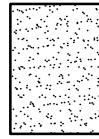

Sand

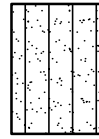

Silty Sand

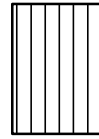

Silt



Sandy Silt

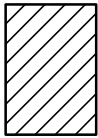

Clay

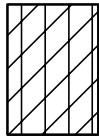

Silty Clay

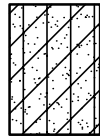

Clayey Silty Sand



Glacial Till

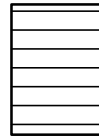

Shale

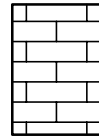

Bedrock

MONITORING WELL AND PIEZOMETER CONSTRUCTION

MONITORING WELL CONSTRUCTION

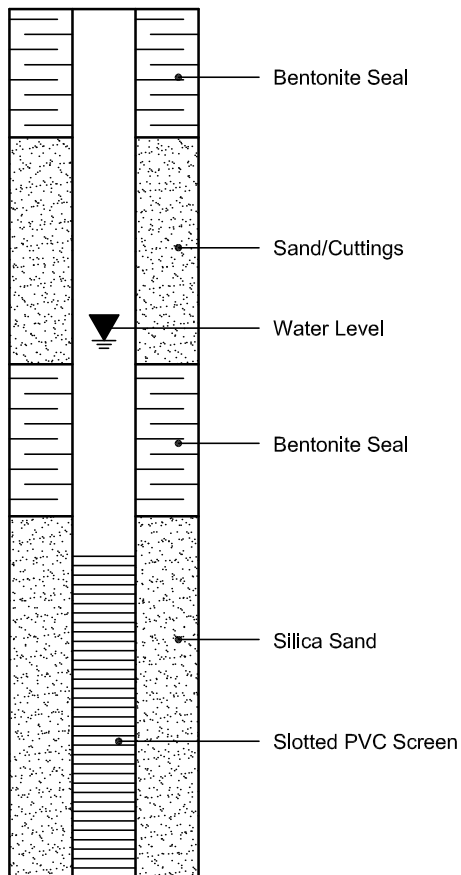

PIEZOMETER CONSTRUCTION

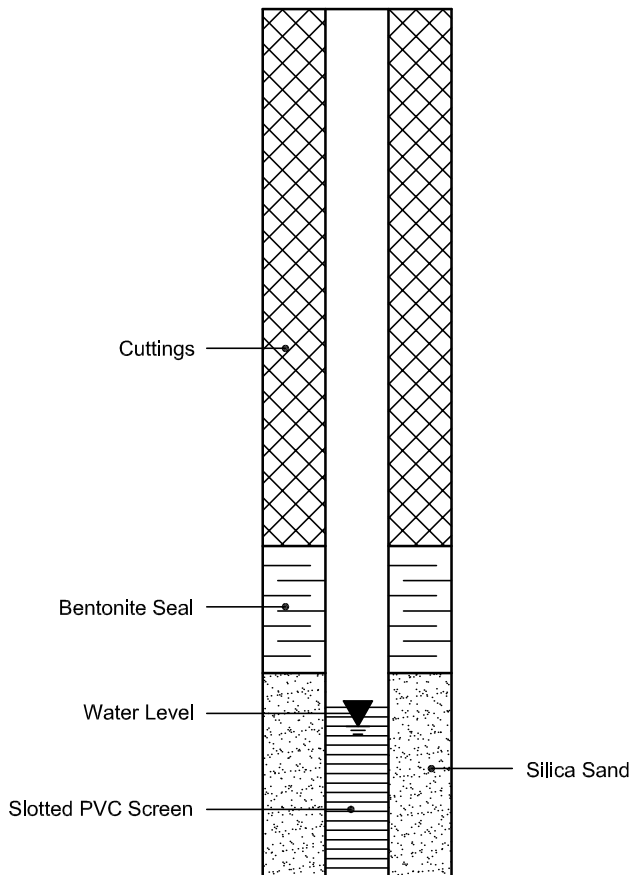

Certificate of Analysis

Report Date: 29-Sep-2022

Client: Paterson Group Consulting Engineers

Order Date: 23-Sep-2022

Client PO: 55869

Project Description: PG6401

Client ID:	BH2-22-SS9	-	-	-	-
Sample Date:	22-Sep-22 09:00	-	-	-	-
Sample ID:	2239598-01	-	-	-	-
Matrix:	Soil	-	-	-	-
MDL/Units					

Physical Characteristics

% Solids	0.1 % by Wt.	64.9	-	-	-	-
----------	--------------	------	---	---	---	---

General Inorganics

pH	0.05 pH Units	7.89	-	-	-	-
Resistivity	0.1 Ohm.m	31.1	-	-	-	-

Anions

Chloride	5 ug/g	15	-	-	-	-
Sulphate	5 ug/g	58	-	-	-	-

APPENDIX 2

FIGURE 1 - KEY PLAN

DRAWING PG6401-1 - TEST HOLE LOCATION PLAN

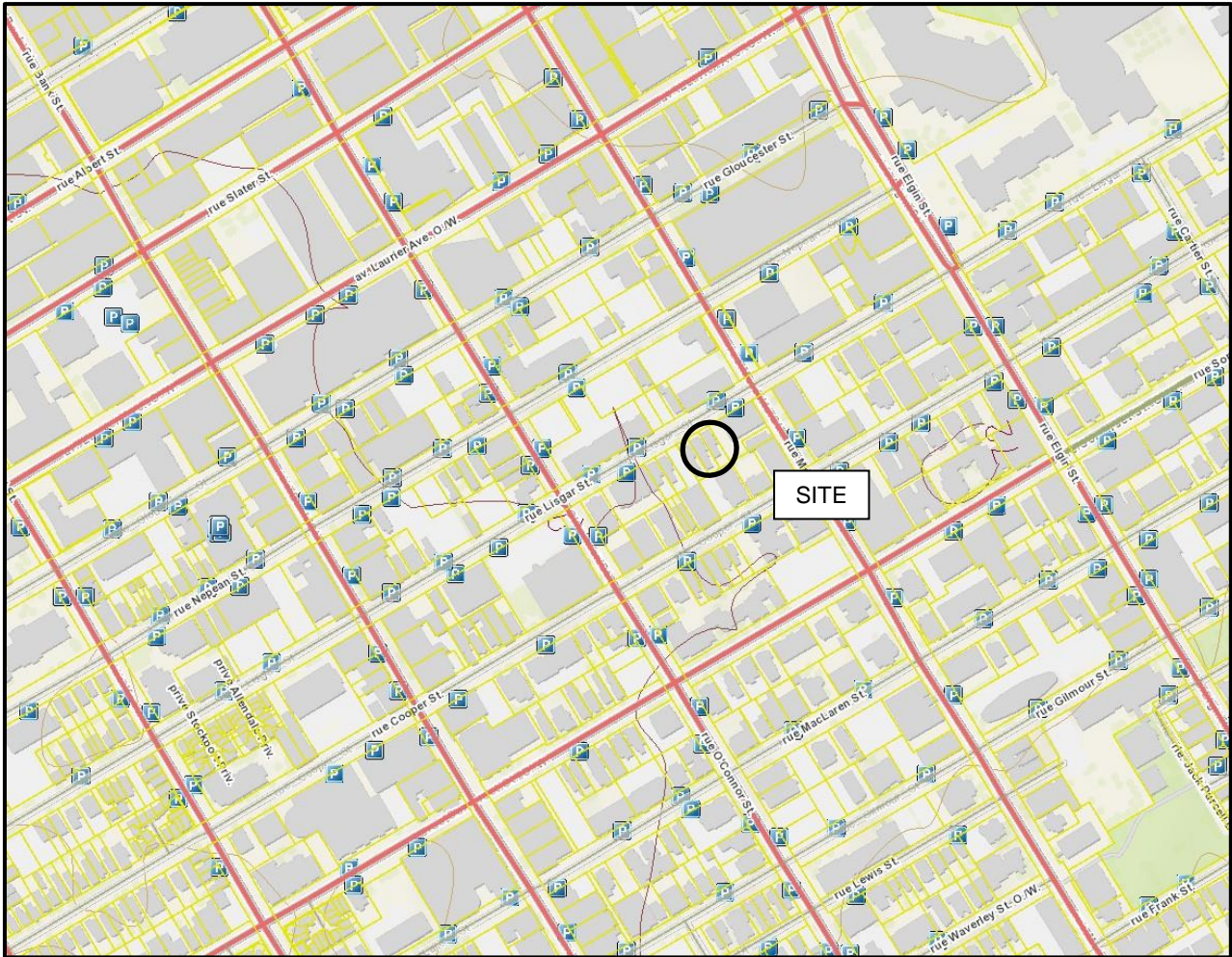
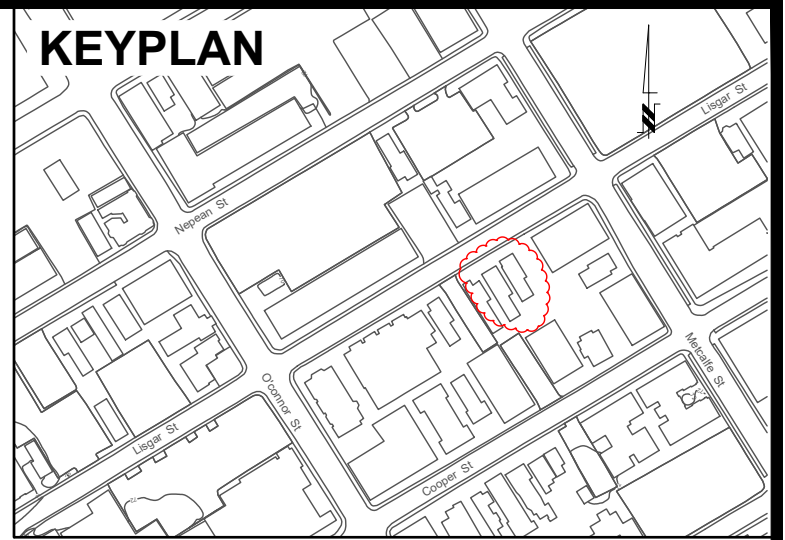
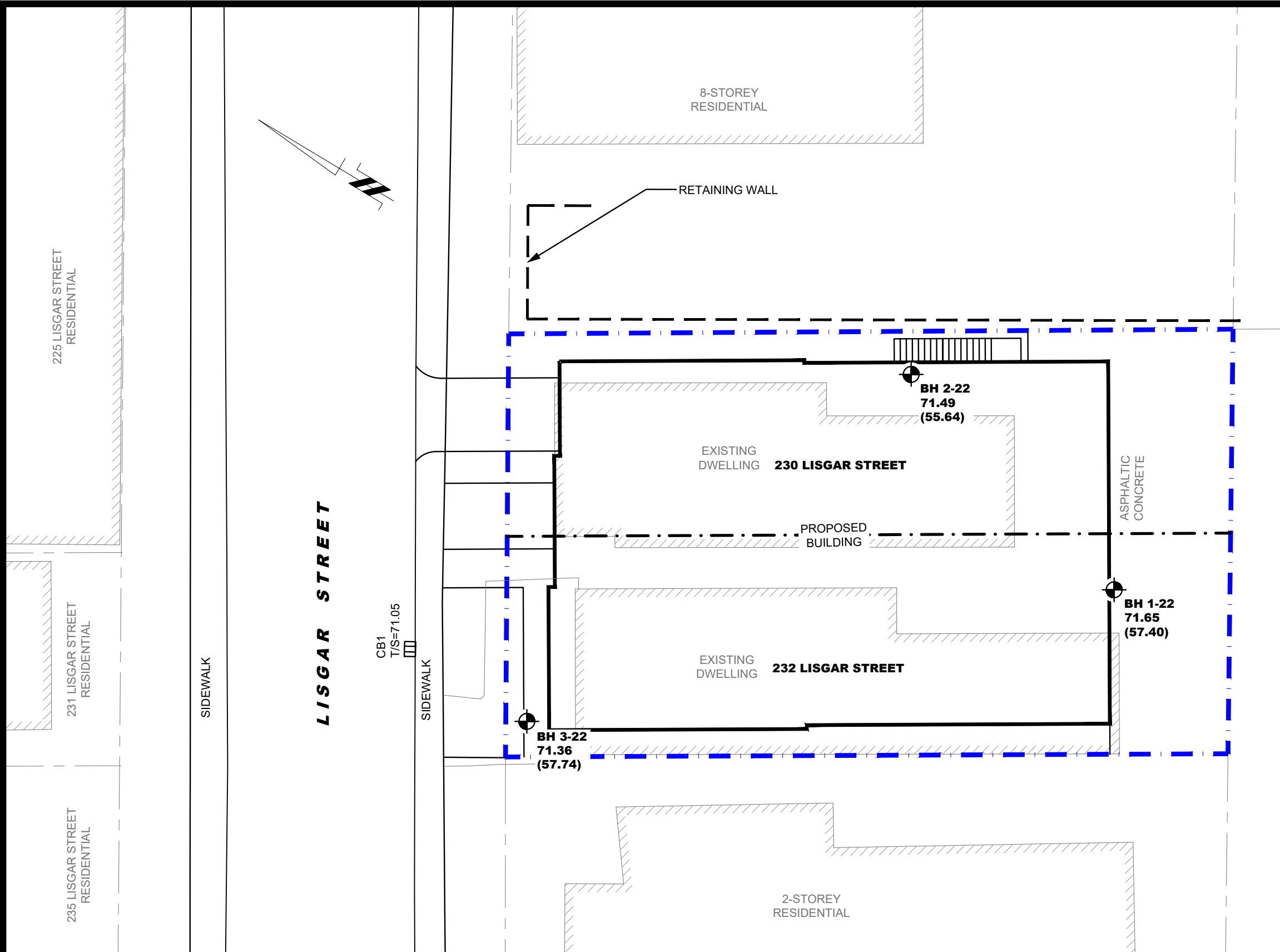

FIGURE 1

KEY PLAN



LEGEND:

BOREHOLE LOCATION

71.65 GROUND SURFACE ELEVATION (m)

(57.40) PRACTICAL REFUSAL TO DCPT ELEVATION (m)

CONCEPTUAL PLAN PROVIDED BY PROJECT STUDIO.

GROUND SURFACE ELEVATIONS AT BOREHOLE LOCATIONS ARE REFERENCED TO A GEODETIC DATUM.

SCALE: 1:200

PATERSON GROUP

9 AURIGA DRIVE
OTTAWA, ON
K2E 7T9
TEL: (613) 226-7381

NO.	REVISIONS	DATE	INITIAL
1	CLIENT NAME UPDATED	11/08/2022	YT

230 LISGAR STREET INC.

**GEOTECHNICAL INVESTIGATION
PROPOSED MULTI-STOREY BUILDING
230-232 LISGAR STREET**

OTTAWA, ONTARIO

Title: **TEST HOLE LOCATION PLAN**

Scale:	1:200	Date:	10/2022
Drawn by:	GK	Report No.:	PG6401-1
Checked by:	YT	Dwg. No.:	PG6401-1
Approved by:	MS	Revision No.:	1

APPENDIX 3

RELEVANT MEMORANDUMS



re: Geotechnical Response to City Comments
Proposed Residential Building
230-232 Lisgar Street - Ottawa
to: 230 Lisgar Street Inc. – **Mr. Albert Falsetto** – a.falsetto@rogers.com
to: Fotenn – **Ms. Jillian Simpson** – simpson@fotenn.com
date: October 18, 2023
file: PG6401-MEMO.01 Revision 2

Further to your request and authorization, Paterson Group (Paterson) prepared the current memorandum to provide geotechnical responses to City of Ottawa comments regarding the proposed residential building. This memorandum should be read in conjunction with Paterson Geotechnical Report PG6401 -1 Revision 2 dated October 18, 2023.

Comment 1.12:

Please submit a letter stating that the latest Grading and Servicing Plan has been reviewed and that it complies with the recommendations and statements of the latest Geotechnical Investigation.

Response:

Paterson prepared a memo for the grading plan review for the proposed building at the aforementioned site. Please refer to our grading plan review memo Report PG6401-MEMO.02 Revision 1 dated May 23, 2023. The proposed grading is considered acceptable from a geotechnical perspective.

Comment 1.13:

Please speak to the foundation design at the proposed USF at 64.50m. Further to section 5.3 of the report, please confirm that a Conventional Shallow foundation on silty clay layer is still an option for this development. If not, please revise this section accordingly.

Response:

Our recommendations for the foundation design are provided under section 5.3-*Foundation Design*, in the aforementioned geotechnical report. The foundation system will be dependant on the design building loading and founding depth. For the proposed USF at geodetic elevation 64.5 m, conventional footings placed on undisturbed stiff brown silty clay bearing surface, using the proposed allowable bearing capacity, is considered acceptable, from a geotechnical perspective.





Comment 1.14:

As per geotechnical investigation and reporting guideline, Where the building will be supported on deep foundations, the investigation should extend to the confirmed bedrock surface. Please revise.

Response:

The subsurface conditions encountered within the drilled boreholes are generally consistent across the site. Furthermore, findings of the current investigation are in agreement with the available historical soil information and geological mapping in the area. In addition, the depth to bedrock has been confirmed through completing DCPT in all boreholes. For the deep foundation system, it is required to confirm the design pile bearing capacity during installation, as stated under section 5.3- Foundation design, in the aforementioned geotechnical report. Therefore, the available information is considered sufficient, from a geotechnical perspective, to provide recommendations for the design of the deep foundation system, provided the pile carrying capacity is confirmed through field testing during construction.

Comment 1.15:

Please discuss protection of retaining wall on the east side of subject property during the excavation/temporary shoring work.

Response:

Due to the depth of excavation, a temporary shoring system will be required to complete the excavation and construction of the proposed two underground parking levels. The shoring system should take into account support of the existing structures, including the existing neighbouring concrete retaining wall along the east side of the property. Based on our review of the available information, it is understood that the neighbouring building adjacent to the east property limit has an underground parking structure. It is anticipated that the existing underground parking extends to the property limit. Therefore, it is anticipated that the existing concrete wall is supported on the foundation wall of the underground parking and will not require underpinning or shoring.

However, this should be confirmed during construction by excavating test pits to confirm the USF and horizontal setback of the existing adjacent underground parking structure. If the retaining wall is supported on overburden, then it should be underpinned or shored.





Comment 1.16:

Please be advised that any encroachment into the public right-of-way will require a municipal consent agreement. This will be for, including but not limited, any shoring systems, and or tiebacks or any other temporary or permanent features that are included in the design.

Response:

Noted.

We trust that the current submission meets your immediate requirements.

Best Regards,

Paterson Group Inc.

Maha K. Saleh, P.Eng



Faisal Abou- Seido, P.Eng.





re: Grading and Site Servicing Plans Review
Proposed Residential Building
230-232 Lisgar Street – Ottawa, Ontario
to: 230 Lisgar Street Inc. – Mr. Albert Falsetto – a.falsetto@rogers.com
to: Fotenn – Ms. Jillian Simpson – simpson@fotenn.com
date: October 18, 2023
file: PG6401-MEMO.02 Revision 2

Further to your request and authorization, Paterson Group (Paterson) prepared the current memorandum to provide a review from a geotechnical perspective for the grading and site servicing plans for the proposed residential building at the aforementioned site. This memorandum should be read in conjunction with Paterson Geotechnical Report PG6401 -1 Revision 2 dated October 18, 2023.

1.0 Grading Plan Review

Paterson reviewed the following grading plans prepared by Novatech, regarding the aforementioned residential building:

- Grading and Erosion and Sediment Control Plan – 230-232 Lisgar Street - Project No. 122160 – Drawing No. 122160-GR - Revision 3, dated July 21, 2023.
- Existing Condition and Removals Plan – 230-232 Lisgar Street - Project No. 122160 – Drawing No. 122160-REM - Revision 2, dated May 19, 2023.

Based on our review of the above noted grading plans, the proposed grade raises within the aforementioned site are within the recommended permissible grade raise of **2.0 m**. No exceedances were noted for any area within the subject site. Therefore, the proposed grade raises are generally acceptable from a geotechnical perspective and will not require the use of lightweight fill at this time.

2.0 Site Servicing Plan Review

Paterson reviewed the following site servicing drawings prepared by Novatech for the aforementioned development:

- General Plan of Services – 230-232 Lisgar Street - Project No. 122160 – Drawing No. 122160-GP - Revision 3, dated July 21, 2023.
- Pre-development Storm Drainage Plan – 230-232 Lisgar Street - Project No. 122160 – Drawing No. 122160-STM1 - Revision 2, dated May 19, 2023.
- Post-development Stormwater Management Plan – 230-232 Lisgar Street - Project No. 122160 – Drawing No. 122160-STM1 - Revision 2, dated May 19, 2023.





Based on our review of the above noted site service plans, The services were found to be outside of the lateral support zone of the proposed footing and be considered to be acceptable from a geotechnical perspective. However, insufficient frost protection has been provided for the storm and sanitary sewer services. At these locations, the storm sewer services are located within the frost zone, approximately 2.1 m below the finished grade.

Refer to Figure 1, attached to the current memorandum, which demonstrates these approximate locations. In the following section, frost protection of the site servicing is recommended where insufficient frost cover has been provided.

3.0 Geotechnical Recommendations

Any portion of the services where the invert level is installed at a depth of 1.8 m below the finished grade or deeper is considered to have sufficient soil cover for frost protection. Where insufficient soil cover is present above the invert of storm and sanitary sewer pipes, the following frost protection criteria should be followed:

Table 1 - Rigid Insulation Recommendations for Storm and Sanitary Sewer Pipes with Reduced Soil Cover			
Thermal Condition	Soil Cover Provided (mm)	Insulation Dimensions	
		Thickness (mm)	Extension (mm)
Unheated	600 to 900	125	Extend 1200 mm horizontally beyond edge face of the sewer
	900 to 1200	100	Extend 1200 mm horizontally beyond edge face of the sewer
	1200 to 1500	75	Extend 900 mm horizontally beyond edge face of the sewer
	1500 to <1800	50	Extend 600 mm horizontally beyond edge face of the sewer
Notes: All designs are based on a freezing index of 1000°C-days			

All rigid insulation should consist of either Dow Chemical High-Load 40 (HI-40), Styro Rail SR.P400, or equivalent approved by Paterson. The placement of all insulation within the service trenches must be reviewed and approved by Paterson personnel at the time of construction.



We trust that the current submission meets your immediate requirements.

Best Regards,

Paterson Group Inc.

Maha K. Saleh, P.Eng



Faisal I. Abou-Seido, P.Eng.

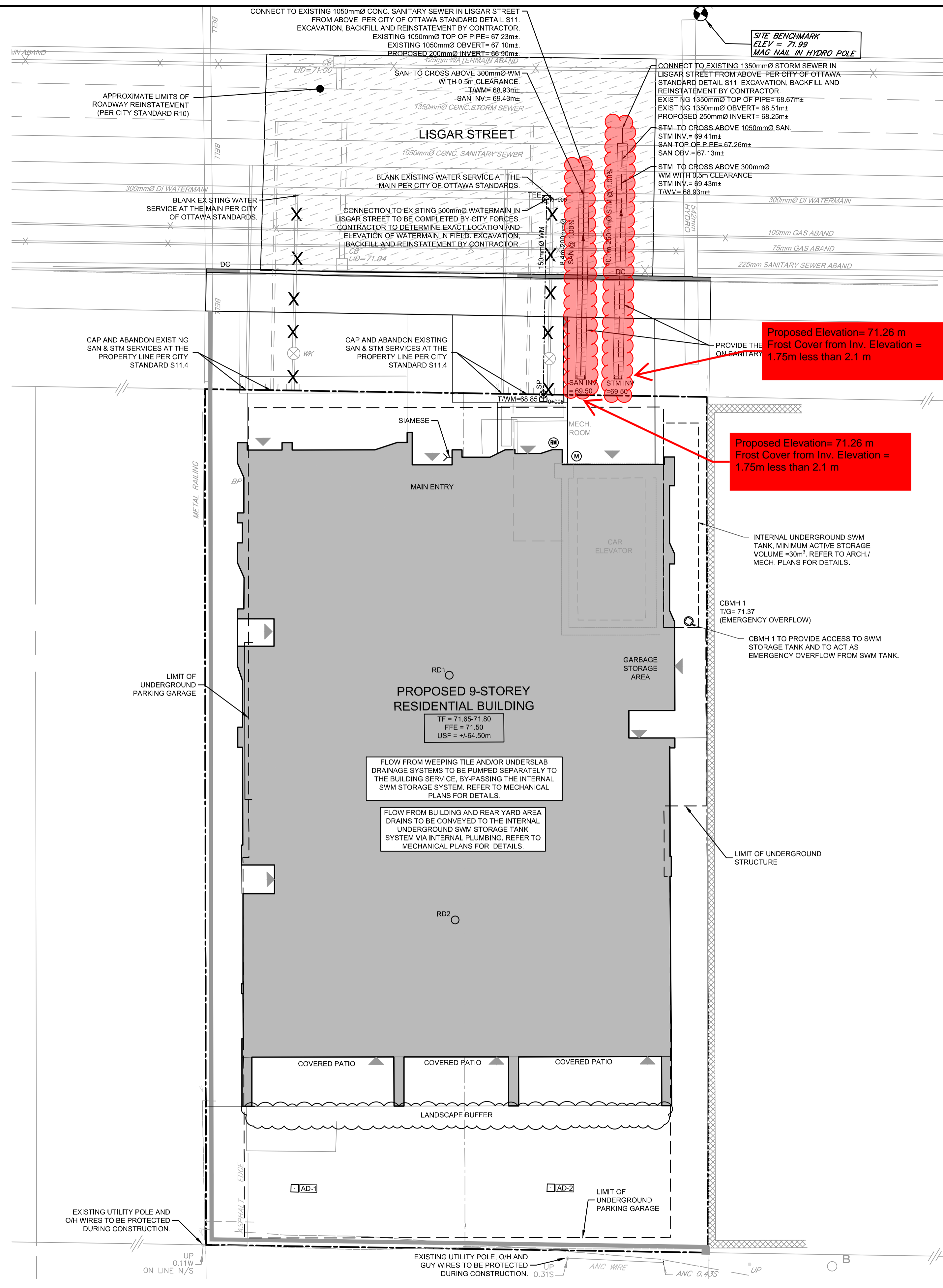

INTERNAL SWM STORAGE SYSTEM

DESIGN EVENT	STORAGE SYSTEM CONTROLLED FLOW	STORAGE VOLUMES	
		REQUIRED	PROVIDED
1:2 YR		5.7 m ³	>30 m ³
1:5 YR		9.1 m ³	
1:100 YR		23.0 m ³	
1:100+20%		29.5 m ³	

NOTES:

- ALL DRAINAGE FROM AREA A-2 (PROPOSED AMENITY AREA DECK DRAINS AND ALL ROOF DRAINS) TO BE DIRECTED TO THE INTERNAL STORMWATER STORAGE SYSTEM. REFER TO ARCHITECTURAL AND MECHANICAL PLANS FOR DETAILS.
- REFER TO ARCHITECTURAL AND STRUCTURAL PLANS FOR EXACT SIZE AND DETAILS OF INTERNAL STORMWATER STORAGE SYSTEM.
- REFER TO ARCHITECTURAL AND MECHANICAL PLANS FOR LOCATION AND CONNECTIONS AND DETAILS OF THE INTERNAL STORMWATER STORAGE SYSTEM.

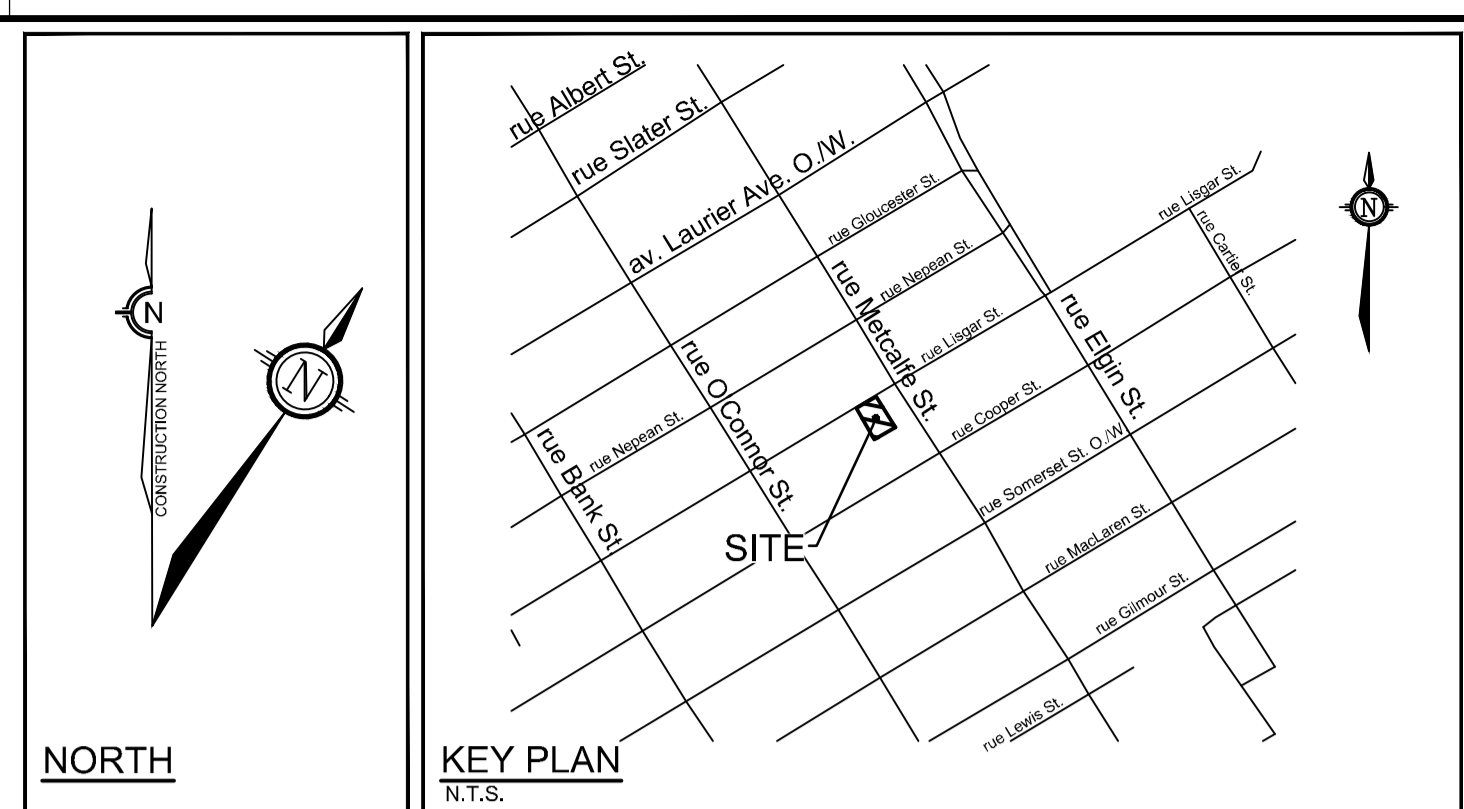
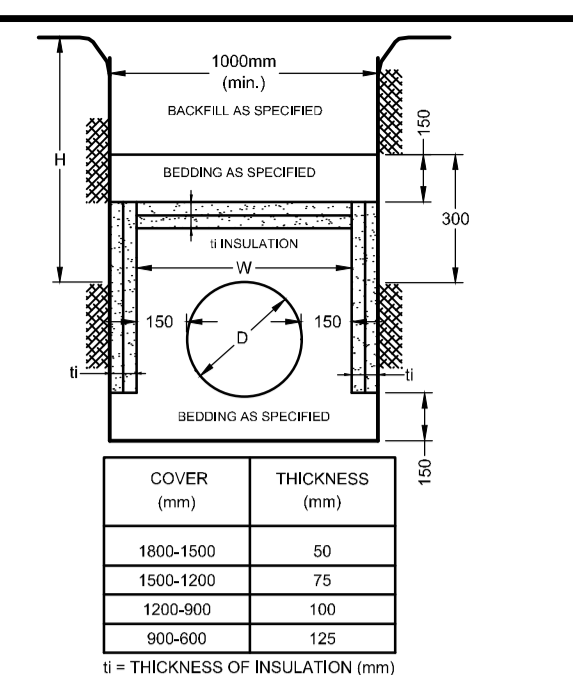

INSULATION DETAIL FOR SHALLOW SEWERS ONLY

LEGEND

---	PROPERTY LINE
---	PROPOSED SANITARY SEWER
---	PROPOSED STORM SEWER
---	PROPOSED THERMAL INSULATION
○	PROPOSED CATCHBASIN MANHOLE
○	AREA DRAIN
○	ROOF DRAIN
○	PROPOSED WATER METER AND REMOTE METER
○	PROPOSED BARRIER CURB
○	PROPOSED DEPRESSED CURB
○	PROPOSED WATER SERVICE AND DIAMETER
○	PROPOSED STAND POST / VALVE & VALVE BOX
○	PROPOSED TEE CW THRUST BLOCK
---	ROAD REINSTATEMENT LIMIT
Y	PROPOSED SIEMSE CONNECTION
C	PROPOSED CAP
---	PROPOSED BUILDING ENTRANCE
---	UNDERGROUND PARKING LIMIT
---	RETAINING WALL
X	REMOVALS
FF	FINISHED FLOOR ELEVATION
TF	TOP OF FOUNDATION WALL ELEVATION
USF	UNDERSIDE OF FOOTING ELEVATION
---	EXISTING CONCRETE CURB
---	EXISTING SANITARY SEWER
---	EXISTING STORM SEWER
---	EXISTING CATCHBASIN CW CATCHBASIN LEAD
WK	EXISTING WATERMAIN AND WATER KEY
EX UP	EXISTING UTILITY POLE CW W/ ANCHOR WIRES
---	EXISTING RETAINING WALL

GENERAL NOTES:

- COORDINATE AND SCHEDULE ALL WORK WITH OTHER TRADES AND CONTRACTORS.
- DETERMINE THE EXACT LOCATION, SIZE, MATERIAL AND ELEVATION OF ALL EXISTING UTILITIES PRIOR TO COMMENCING CONSTRUCTION. PROTECT AND ASSUME RESPONSIBILITY FOR ALL EXISTING UTILITIES WHETHER OR NOT SHOWN ON THIS DRAWING.
- OBTAIN ALL NECESSARY PERMITS AND APPROVALS FROM THE CITY OF OTTAWA BEFORE COMMENCING CONSTRUCTION.
- BEFORE COMMENCING CONSTRUCTION OBTAIN AND PROVIDE PROOF OF COMPREHENSIVE, ALL RISK AND OPERATIONAL LIABILITY INSURANCE FOR \$5,000,000.00. INSURANCE POLICY TO NAME OWNERS, ENGINEERS AND ARCHITECTS AS CO-INSURED.
- COMPLETE ALL WORKS IN ACCORDANCE WITH THE MOST CURRENT CITY OF OTTAWA STANDARDS AND SPECIFICATIONS USING THE CURRENT GUIDELINES, BYLAWS AND STANDARDS INCLUDING MATERIALS OF CONSTRUCTION, DISINFECTANT AND ALL RELEVANT REFERENCES TO OPSS, OPSD & AWWA GUIDELINES - ALL CURRENT VERSIONS AND AS AMENDED.
- RESTORE ALL DISTURBED AREAS ON-SITE AND OFF-SITE, INCLUDING TRENCHES AND SURFACES ON PUBLIC ROAD ALLOWANCES TO EXISTING CONDITIONS OR BETTER TO THE SATISFACTION OF MUNICIPAL AUTHORITIES.
- REMOVE FROM SITE ALL EXCESS EXCAVATED MATERIAL, ORGANIC MATERIAL AND DEBRIS UNLESS OTHERWISE INSTRUCTED BY ENGINEER. EXCAVATE AND REMOVE FROM SITE ANY CONTAMINATED MATERIAL. ALL CONTAMINATED MATERIAL SHALL BE DISPOSED OF AT A LICENSED LANDFILL FACILITY.
- ALL ELEVATIONS ARE GEODETIC.
- REFER TO GEOTECHNICAL INVESTIGATION REPORT (PG6401-1, DATED OCTOBER 26, 2022), PREPARED BY PATERSON GROUP INC., CONSTRUCTION RECOMMENDATIONS AND GEOTECHNICAL INSPECTION REQUIREMENTS. THE GEOTECHNICAL CONSULTANT IS TO REVIEW ON-SITE CONDITIONS AFTER EXCAVATION PRIOR TO PLACEMENT OF THE GRANULAR MATERIAL.
- REFER TO ARCHITECT'S AND LANDSCAPE ARCHITECT'S DRAWINGS FOR BUILDING AND HARD SURFACED AREAS AND DIMENSIONS.
- REFER TO THE 'DEVELOPMENT SERVICING STUDY AND STORMWATER MANAGEMENT REPORT' (R-2022-151) PREPARED BY NOVATECH.
- SAW CUT AND KEYGRIND ASPHALT AT ALL ROAD CUTS AND ASPHALT TIE-IN POINTS AS PER CITY OF OTTAWA STANDARDS (R10).

SEWER NOTES:

- SUPPLY AND CONSTRUCT ALL SEWERS AND APPURTENANCES IN ACCORDANCE WITH THE MOST CURRENT CITY OF OTTAWA STANDARDS AND SPECIFICATIONS - ALL CURRENT VERSIONS AND AS AMENDED.
- SPECIFICATIONS:

ITEM	SPEC. No.	REFERENCE
STORM / SANITARY MANHOLE (12000)	701.010	OPSD
SANITARY MANHOLE FRAME AND COVER	401.010 - TYPE 'A'	OPSD
STORM/CATCHBASIN MANHOLE (18000)	701.012	OPSD
STORM/CBHM FRAME AND COVER	401.010 - TYPE 'B'	OPSD
WATERTIGHT MANHOLE FRAME AND COVER	401.030	OPSD
CATCHBASIN (600V00)	705.010	CITY OF OTTAWA
CATCHBASIN FRAME & COVER	S19	CITY OF OTTAWA
SEWER TRENCH	S6	CITY OF OTTAWA
STORM SEWER	PVC DR 35 (450mmØ PIPE AND SMALLER)	CITY OF OTTAWA
SANITARY SEWER	CONCRETE 65-D (600mmØ PIPE AND LARGER)	CITY OF OTTAWA
	PVC DR 35	
- THE SANITARY SERVICE LATERAL SHALL BE EQUIPPED WITH BACKFLOW PREVENTERS WITHIN THE BUILDING FOOTPRINT AS PER CITY OF OTTAWA STANDARD DETAILS S14.1 OR S14.2. REFER TO MECHANICAL PLANS FOR DETAILS.
- THE STORM SERVICE LATERAL SHALL BE EQUIPPED WITH A BACKFLOW PREVENTER WITHIN THE BUILDING FOOTPRINT AS PER CITY OF OTTAWA STANDARD DETAILS S14. REFER TO MECHANICAL PLANS FOR DETAILS.
- SERVICES ARE TO BE CONSTRUCTED TO 1.0m FROM FACE OF BUILDING AT A MINIMUM SLOPE OF 1.0%.
- PIPE BEDDING, COVER AND BACKFILL ARE TO BE COMPACTED TO AT LEAST 95% OF THE STANDARD PROCTOR MAXIMUM DRY DENSITY. THE USE OF CLEAR CRUSHED STONE AS A BEDDING LAYER SHALL NOT BE PERMITTED.
- INSULATE ALL PIPES (SAN / STM) THAT HAVE LESS THAN 1.8m COVER WITH HI-40 INSULATION PER INSULATION DETAIL FOR SHALLOW SEWERS. PROVIDE 150mm CLEARANCE BETWEEN PIPE AND INSULATION.
- CONCRETE MANHOLES ARE TO BE 1200mmØ STRUCTURES UNLESS OTHERWISE NOTED ON THE DRAWING. FLEXIBLE CONNECTIONS ARE REQUIRED FOR CONNECTING PIPES TO MANHOLES (FOR EXAMPLE KOR-N-SEAL, PSX POSITIVE SEAL AND DURASEAL). THE CONCRETE CRADLE FOR THE PIPE CAN BE ELIMINATED.
- TYPICAL STORM MANHOLES AND CATCHBASIN MANHOLES ARE TO HAVE 300mm SUMP UNLESS OTHERWISE INDICATED.
- THE CONTRACTOR IS TO TELEVIEW (CCTV) ALL PROPOSED SEWERS, 200mmØ OR GREATER PRIOR TO BASE COURSE ASPHALT. UPON COMPLETION OF CONTRACT, THE CONTRACTOR IS RESPONSIBLE TO FLUSH AND CLEAN ALL SEWERS & APPURTENANCES. PROVIDE A COPY OF ALL CCTV INSPECTION REPORTS TO THE ENGINEER FOR REVIEW.
- CONTRACTOR TO PROVIDE THE CONSULTANT WITH A GENERAL PLAN OF SERVICES INDICATING ALL APPLICABLE SERVICING AS-BUILT INFORMATION SHOWN ON THIS PLAN. AS-BUILT INFORMATION MUST INCLUDE: PIPE MATERIAL, SIZES, LENGTHS, SLOPES, INVERT AND T/G ELEVATIONS, STRUCTURE LOCATIONS AND ANY ALIGNMENT CHANGES, ETC.
- THE OWNER SHALL REQUIRE THAT THE SITE SERVICING CONTRACTOR PERFORM FIELD TESTS FOR QUALITY CONTROL OF ALL SANITARY SEWERS. LEAKAGE TESTING SHALL BE COMPLETED IN ACCORDANCE WITH OPSS 410.07.16, 410.07.16.04 AND 407.07.24. DYE TESTING IS TO BE COMPLETED ON ALL SANITARY SERVICES TO CONFIRM PROPER CONNECTION TO THE SANITARY SEWER MAIN. THE FIELD TESTS SHALL BE PERFORMED IN THE PRESENCE OF A CERTIFIED PROFESSIONAL ENGINEER WHO SHALL SUBMIT A CERTIFIED COPY OF THE TEST RESULTS.

WATERMAIN NOTES:

- SUPPLY AND CONSTRUCT ALL WATERMANS AND APPURTENANCES IN ACCORDANCE WITH THE CITY OF OTTAWA STANDARDS AND SPECIFICATIONS - ALL CURRENT VERSIONS AND AS AMENDED.
- SPECIFICATIONS:

ITEM	SPEC. No.	REFERENCE
WATERMAIN TRENCHING	W17	CITY OF OTTAWA
HYDRANT INSTALLATION	W19	CITY OF OTTAWA
THERMAL INSULATION IN SHALLOW TRENCHES	W22	CITY OF OTTAWA
THERMAL INSULATION BY OPEN STRUCTURES	W23	CITY OF OTTAWA
VALVE BOX ASSEMBLY	W24	CITY OF OTTAWA
WATERMAIN CROSSING BELOW SEWERS	W25	CITY OF OTTAWA
CATHODIC PROTECTION FOR PVC WATERMANS	W40	CITY OF OTTAWA
WATERMAIN MATERIAL	PVC DR 18 (100mm AND LARGER)	
- EXCAVATION, INSTALLATION, BACKFILL AND RESTORATION OF ALL WATERMANS BY THE CONTRACTOR. CONNECTIONS AND

PROPOSED 150mmØ WATER SERVICE TABLE

Station	F/G ELEVATION	TOP OF WATERMAIN	DESCRIPTION
0+000.00	71.13	68.93*	ROLL 150mmØ WM CONNECTION TO EX. 300mmØ DI WM
0+007.83	71.39	68.84**	VALVE AND VALVE BOX (SP) 0.5m OFF OF CAP (AT PROPERTY LINE)
0+008.11	71.41	68.85**	CAP AT 1.0m FROM FOUNDATION WALL

* CONNECTION TO EXISTING 300mmØ DUCTILE IRON WATERMAIN. EXACT ELEVATION TO BE FIELD DETERMINED.
** PROVIDE THERMAL INSULATION AS PER CITY OF OTTAWA DETAIL W22 IN SHALLOW TRENCHES AND/OR CITY OF OTTAWA W23 ADJACENT TO OPEN STRUCTURES.

BENCHMARK NOTES:

- ELEVATIONS ARE GEODETIC AND ARE REFERRED TO CITY OF OTTAWA CONTROL POINT 2011-0007 HAVING A PUBLISHED ELEVATION OF 80.55 METRES.

Figure 1 - Approximate Locations of Frost Protection of The Site Servicing and Insulation Recommendations

NOTE: THE POSITION OF ALL POLE LINES, CONDUITS, WATERMANS, SEWERS AND OTHER UNDERGROUND AND OVERGROUND UTILITIES AND STRUCTURES IS NOT NECESSARILY SHOWN ON THE CONTRACT DRAWINGS, AND WHERE SHOWN, THE ACCURACY OF THE POSITION OF SUCH UTILITIES AND STRUCTURES IS NOT GUARANTEED. BEFORE STARTING WORK, DETERMINE THE EXACT LOCATION OF ALL SUCH UTILITIES AND STRUCTURES AND ASSUME ALL LIABILITY FOR DAMAGE TO THEM.

No.	REVISION	DATE	BY
3.	RE-ISSUED FOR SPC APPLICATION	JULY 21/23	FST
2.	REVISED PER CITY COMMENTS	MAY 19/23	FST
1.	ISSUED FOR SPC APPLICATION	NOV 11/22	FST

SCALE	DESIGN
1:100	CV
	CHECKED
	FST
	DRAWN
	CV
	CHECKED
	FST
	APPROVED
	FST

FOR REVIEW ONLY

PROFESSIONAL ENGINEER
F.S. THAUVEYTE
 100041399
 JULY 21, 2023
 PROVINCE OF ONTARIO

NOVATECH
 Engineers, Planners & Landscape Architects
 Suite 200, 240 Michael Cowpland Drive
 Ottawa, Ontario, Canada K2M 1P6
 Telephone: (613) 254-9643
 Facsimile: (613) 254-5867
 Website: www.novatech-eng.com

LOCATION	DRAWING NAME	PROJECT No.
CITY OF OTTAWA 230-232 LISGAR STREET	GENERAL PLAN OF SERVICES	122160
		REV # 3
		DRAWING No.
		122160-GP
		PLAN #18902

M:\2023\122160\CAD\CAD\122160-GP.dwg, GP, May 25, 2023 - 4:19pm, szll

D07-12-22-0166