

ACCESS PROPERTY DEVELOPMENT INC

415 LEGGET DRIVE STORMWATER MANAGEMENT REPORT

MARCH 24, 2023





415 LEGGET DRIVE STORMWATER MANAGEMENT REPORT

ACCESS PROPERTY DEVELOPMENT INC

6TH SUBMISSION

PROJECT NO.: 219-00058-04

CLIENT REF:

DATE: MARCH 24, 2023

WSP
SUITE 300
2611 QUEENSVIEW DRIVE
OTTAWA, ON, CANADA K2B 8K2

T: +1 613 829-2800

F: +1 613 829-8299

WSP.COM

REVISION HISTORY

FIRST ISSUE

October 22 nd , 2021	Draft SWM Report			
Prepared by	Reviewed by	Approved By		
MO	AJ	AJ		
SECOND ISSUE				
March 25 th , 2022	SWM Report			
Prepared by	Reviewed by	Approved By		
MO	AJ	AJ		
THIRD ISSUE				
August 4 th , 2022	SWM Report			
Prepared by	Reviewed by	Approved By		
KK	AJ	AJ		
FOURTH ISSUE				
November 21 st , 2022	SWM Report			
Prepared by	Reviewed by	Approved By		
KK	AJ	AJ		
FIFTH ISSUE				
January 20 th , 2023	SWM Report			
Prepared by	Reviewed by	Approved By		
KK	AJ	AJ		
SIXTH ISSUE				
March 24 th , 2023	SWM Report			

Prepared by	Reviewed by	Approved By		
KK	AJ	LMG		

SIGNATURES

PREPARED BY



Kathryn Kerker, M.A.Sc.
Designer, Water Resources

March 24th, 2023

Date

APPROVED¹ BY

March 24th, 2023

Louis-Marc Girard, P.Eng.
Manager, Municipal Engineering

Date

WSP Canada Inc. (“WSP”) prepared this report solely for the use of the intended recipient, ACCESS PROPERTY DEVELOPMENT INC, in accordance with the professional services agreement. The intended recipient is solely responsible for the disclosure of any information contained in this report. The content and opinions contained in the present report are based on the observations and/or information available to WSP at the time of preparation. If a third party makes use of, relies on, or makes decisions in accordance with this report, said third party is solely responsible for such use, reliance or decisions. WSP does not accept responsibility for damages, if any, suffered by any third party as a result of decisions made or actions taken by said third party based on this report. This limitations statement is considered an integral part of this report.

The original of this digital file will be conserved by WSP for a period of not less than 10 years. As the digital file transmitted to the intended recipient is no longer under the control of WSP, its integrity cannot be assured. As such, WSP does not guarantee any modifications made to this digital file subsequent to its transmission to the intended recipient.

¹ Approval of this document is an administrative function indicating readiness for release and does not impart legal liability on to the Approver for any technical content contained herein. Technical accuracy and fit-for-purpose of this content is obtained through the review process. The Approver shall ensure the applicable review process has occurred prior to signing the document.

CONTRIBUTORS

CLIENT

Access Property Development Inc.

WSP

Water Resources, Designer Kathryn Kerker

Water Resources, Project Engineer Ayham Jadallah

Land Development, Senior Engineer Winston Yang



TABLE OF CONTENTS

1	INTRODUCTION.....	1
1.1	Scope.....	1
1.2	Site Location.....	1
1.3	Stormwater Management Plan Objectives.....	2
1.4	Design Criteria.....	2
2	MODELLING METHODOLOGY.....	3
2.1	Proposed Conditions Model.....	3
3	PRE-DEVELOPMENT CONDITIONS.....	4
3.1	General.....	4
3.2	Rainfall Information.....	5
3.3	Allowable Flow Rates.....	5
4	POST-DEVELOPMENT CONDITIONS.....	6
4.1	General.....	6
4.2	Water Quantity.....	7
4.2.1	Existing Wet Pond.....	8
4.3	Water Quality.....	10
4.4	Floodplain Considerations.....	12
4.5	Temperature Considerations.....	12
4.6	Maintenance Considerations.....	12
5	CONCLUSIONS.....	14

TABLES

TABLE 1: PCSWMM PARAMETERS	3
TABLE 2: PRE-DEVELOPMENT CATCHMENT CHARACTERISTICS.....	4
TABLE 3: PRE-DEVELOPMENT PEAK FLOW RATES.....	5
TABLE 4: POST DEVELOPMENT CATCHMENT CHARACTERISTICS.....	6
TABLE 5: PRE VS POST DEVELOPMENT FLOW RATES.....	7
TABLE 6: PCSWMM MODELING RESULTS	8
TABLE 7: PROPOSED CONDITION PCSWMM RESULTS - WET POND.....	10
TABLE 8: MOE 2003 SWM PLANNING AND DESIGN MANUAL TABLE 3.2	11
TABLE 9: WET POND WATER QUALITY CALCULATIONS	11

FIGURES

FIGURE 1: SITE LOCATION	1
FIGURE 2: 3-HOUR CHICAGO DESIGN STORM HYETOGRAPHS - OTTAWA	5
FIGURE 3: EXISTING POND OUTLET STRUCTURE ...	9
FIGURE 4: PROPOSED POND OUTLET STRUCTURE	9
FIGURE 5: EXISTING DRAINAGE	10

APPENDICES

A	PRE-CONSULTATION MEETING MINUTES AND TECHNICAL COMMENTS
B	EXHIBITS
C	CALCULATIONS & PCSWMM OUTPUT
D	MVCA FLOODPLAIN MAP
E	SUPPORTING DOCUMENTS

1 INTRODUCTION

1.1 SCOPE

WSP Canada Inc. was retained by Access Property Development Inc. to prepare a Stormwater Management (SWM) report for the proposed development at 415 Legget Drive in Ottawa, Ontario. This SWM report examines the potential water quality and quantity impacts of the proposed commercial development and summarizes how each will be addressed in accordance with applicable guidelines.

1.2 SITE LOCATION

The site of the proposed commercial development is located at 415 Legget Drive, Ottawa, Ontario. The subject site is bounded by Solandt Road to the north, Legget Drive to the west, other commercial properties to the south, and a golf course to the east. The site is accessed via Legget Drive and Solandt Road. The site location is shown in Figure 1.

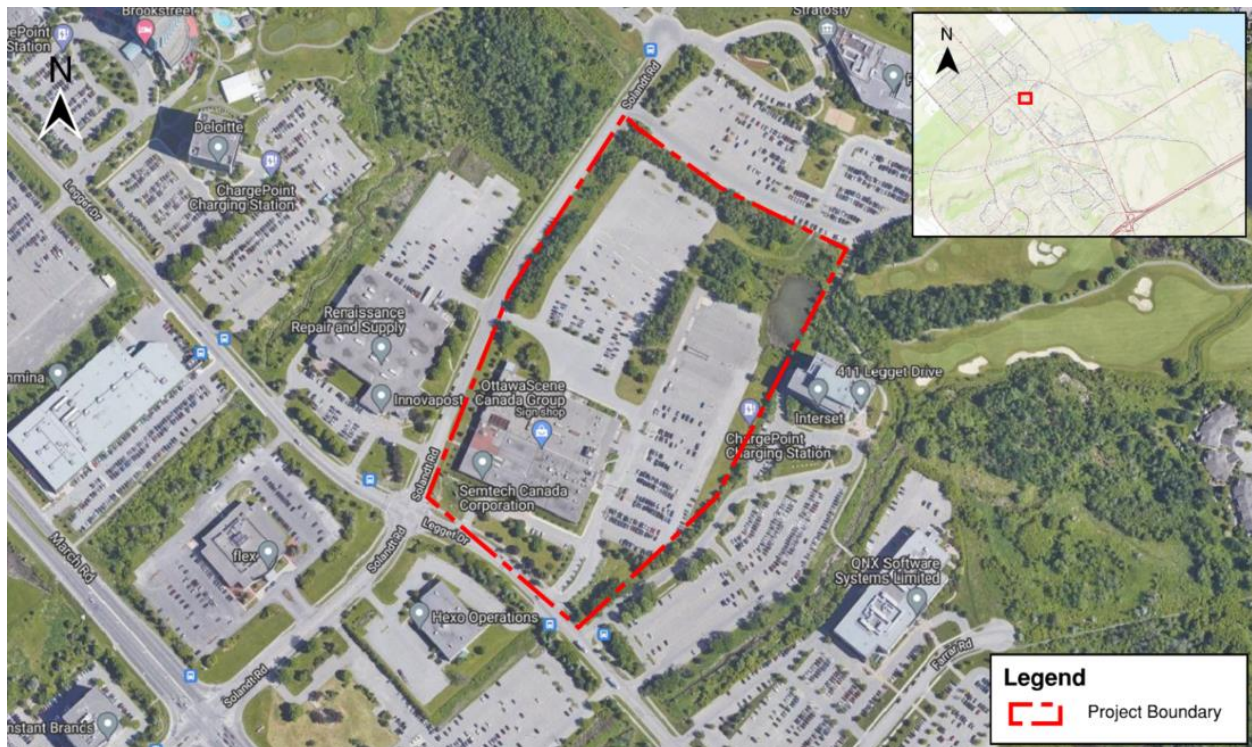

Figure 1: Site Location

1.3 STORMWATER MANAGEMENT PLAN OBJECTIVES

The objectives of the stormwater management plan are as follows:

- Collect and review background information
- Determine the site-specific stormwater management requirements to ensure that the proposals are in conformance with the applicable Provincial, Municipal and Conservation Authority stormwater management and development guidelines.
- Evaluate various stormwater management practices that meet the applicable SWM and development requirements and recommend a preferred strategy.
- Prepare a stormwater management report documenting the strategy along with the technical information necessary for the justification and sizing of the proposed stormwater management facilities.

1.4 DESIGN CRITERIA

Design criteria were obtained through a pre-consultation meeting with the City of Ottawa held on September 27th, 2021 (meeting minutes included in **Appendix A**) and through comments received from the City. Criteria for 415 Legget Drive are as follows:

- **Stormwater Quantity**- An MOE Certificate of Approval was granted for the existing stormwater management pond in 2005. The approval indicates that the 100-year release rate is 310 L/s. Therefore, the target release rate for the proposed works is 310 L/s. The Certificate of Approval is included in **Appendix A**.
- **Storm Quality**- enhanced level of protection per the Mississippi Valley Conservation Authority (MVCA) is required (80% TSS Removal).

2 MODELLING METHODOLOGY

Modelling of the proposed site was completed in PCSWMM. The model includes catchment areas, storage, outlet control, ditches, and the outfall.

2.1 PROPOSED CONDITIONS MODEL

Catchment areas: Subcatchments were delineated based on the proposed discharge locations, which largely follow the existing conditions drainage patterns. Subcatchment imperviousness was calculated based on spatial weighting of the proposed land-use. The standard City of Ottawa values were used for infiltration, depression storage, and roughness coefficient values as described in The subcatchment representing the pond area was set with an imperviousness of 100% and a flow length of 0.1 m as all water landing on the pond surface would immediately enter the pond (i.e. low T_c).

Table 1. The subcatchment representing the pond area was set with an imperviousness of 100% and a flow length of 0.1 m as all water landing on the pond surface would immediately enter the pond (i.e. low T_c).

Table 1: PCSWMM Parameters

PARAMETER	VALUE
N Imperv	0.013
N Perv	0.25
Dstore Imperv (mm)	1.57
Dstore Perv (mm)	4.67
Max. Infil. Rate (mm/hr)	76.2
Min. Infil. Rate (mm/hr)	13.2
Decay Constant (1/hr)	4.14
Drying Time (days)	7

Storage: The existing wet pond was modelled as a storage node with a storage curve based on the proposed site surface (storage curve included in **Appendix C**). The initial depth was set to the permanent pool elevation. The building roof storage was modelled as storage nodes assuming 90% of the roof areas are available for storage. Outlets with the WATTS roof drain stage discharge curve were used to control roof storage outflow to the ditches.

Weir: The weir was modelled based on the proposed weir dimensions discussed in Section 4.2.1. The trapezoidal notch height was determined based on the extended detention water quality volume discussed in Section 4.3.

Ditches: Ditches were modelled as conduits with an irregular or trapezoidal cross-section and a roughness coefficient of 0.035.

Boundary Conditions: The tailwater condition at the outfall to the Kizell Drain was set as a free outfall for evaluation of quantity control and was verified using the 100-year flood elevation.

3 PRE-DEVELOPMENT CONDITIONS

3.1 GENERAL

The subject site is a 7.28 ha parcel of land comprised of two paved parking areas and an existing commercial building. Vehicular access to the site is via two entrances on Legget Drive and Solandt Road. Under pre-development conditions the subject site consists of primarily impervious building and parking area with the exception of the north-east corner of the property which is undeveloped pervious area. Within the north-east corner of the site there is an existing stormwater management wet pond. Existing drainage patterns for the site were determined based on topographic survey information. With the exception of the existing building and a small portion along the north and west border of the site which drains to Solandt Rd, existing site drainage is towards the existing wet pond which discharges into the Kizell Drain. The existing building roof drainage discharges via roof drains into the Solandt Road sewer. It should be noted that the existing building will remain unchanged in the proposed development and therefore no new quantity or quality control measures are proposed for this area (S-BEX). Additionally, as shown on the exhibits found in **Appendix B**, there is approximately 0.28 ha of external drainage area from the adjacent property to the south draining towards the site and into the existing wet pond. The pre-development catchment characteristics are summarized in Table 2 and illustrated in Exhibit 1 and 2 in **Appendix B**.

Table 2: Pre-development Catchment Characteristics

CATCHMENT ID	AREA (ha)	% COVERAGE OF PROJECT AREA	RUNOFF COEFFICIENT
External Drainage Areas to Wet Pond / Kizell Drain			
S-EXT1	0.28		0.35
Un-Controlled Drainage Areas to Solandt Rd			
S-U1	0.76	10.4%	0.23
S-BEX	0.97	13.3%	0.90
Un-Controlled Drainage Areas to Wet Pond / Kizell Drain			
S-U2**	5.55	76.2%	0.63*
TOTAL PROJECT AREA	7.28	100%	0.62
TOTAL (INCL. EXTERNAL DRAINAGE)	7.56		0.61

**Includes "Pond" catchment

3.2 RAINFALL INFORMATION

The rainfall intensity is calculated in accordance with Section 5.4.2 of the Ottawa Sewer Design Guidelines (October, 2012):

Where;

$$i = \left[\frac{A}{(Td + C)^B} \right]$$

- A, B, C = regression constants for each return period (defined in section 5.4.2)
- i = rainfall intensity (mm/hour)
- Td = storm duration (minutes)

The IDF parameters/regression constants are per the Ottawa Sewer Design Guidelines (October, 2012). The 3-hour Chicago storm event was used for the analysis. Hyetographs are shown in Figure 2 below.

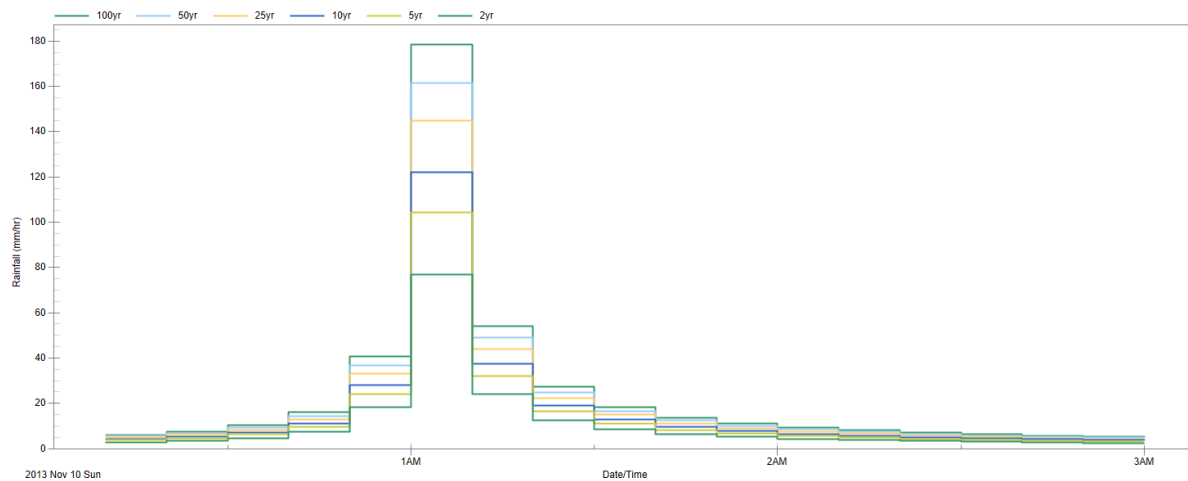

Figure 2: 3-hour Chicago Design Storm Hyetographs - Ottawa

3.3 ALLOWABLE FLOW RATES

As noted in section 1.4, the 100-year release rate from the existing pond will be limited to 310 L/s as indicated in the Certificate of Approval. Outflow to Solandt Rd will be controlled to pre-development rates.

PCSWMM was used to analyze the existing conditions for the site and determine the allowable peak flow rates from the site to Solandt Rd. Results are summarized in Table 3. Detailed PCSWMM results are provided in **Appendix C**. Note that while the existing pond is included in the existing conditions PCSWMM model, these results were not used to determine target flow rates.

Table 3: Pre-Development Peak Flow Rates

OUTFALL	PEAK FLOW RATE (m ³ /sec)					
	2-yr	5-yr	10-yr	25-yr	50-yr	100-yr
OF1 – Solandt Rd	0.22	0.33	0.40	0.50	0.58	0.66
OF2 – Kizell Drain	-	-	-	-	-	0.31

4 POST-DEVELOPMENT CONDITIONS

4.1 GENERAL

The proposed Legget Drive project is a commercial development in Ottawa, Ontario. Post development condition catchment characteristics are summarized in Table 4 and illustrated on Exhibits 3 and 4 found in **Appendix B**. The proposed development includes the construction of two additional commercial buildings over a portion of the two existing parking areas. Vehicular access to the site will continue to be via the existing entrances off Legget Drive and Solandt Road. In general, existing drainage patterns are maintained with the majority of the site draining to the existing wet pond.

Table 4: Post Development Catchment Characteristics

CATCHMENT ID	AREA (HA)	% COVERAGE OF PROJECT AREA	RUNOFF COEFFICIENT
External Drainage Areas to Wet Pond / Kizell Drain			
S-U2 (external portion)	0.08		0.67
S-U4 (external portion)	0.19		0.20
Un-Controlled Drainage Areas to Solandt Rd			
S-U1	0.59	8.1%	0.28
S-BEX	0.97	13.3%	0.90
Un-Controlled Drainage Areas to Wet Pond / Kizell Drain			
S-U2 (internal portion)	2.03	27.8%	0.74
S-U3	0.56	7.7%	0.84
S-U4 (internal portion)	0.22	3.0%	0.21
S-U5	0.18	2.5%	0.20
S-U6	0.05	0.7%	0.20
S-U7	0.37	5.1%	0.20
S-U8	0.20	2.7%	0.20
Pond	0.28	3.8%	1.00
Controlled Drainage Areas to Wet Pond / Kizell Drain			
S-BA	1.12	15.4%	0.90
S-BB	0.72	9.9%	0.90
TOTAL PROJECT AREA	7.28	100%	0.73
TOTAL (INCL. EXTERNAL DRAINAGE)	7.56		0.69

To meet stormwater management objectives, as defined by the design criteria outlined in Section 1.4, the following components have been proposed:

- Roof storage on the two proposed buildings, controlled by WATTS Adjustable Flow Control Roof Drains (or equivalent)
- Existing Wet Pond
- Enhanced grassed swales

The application and sizing of these proposed stormwater management facilities is outlined in the following sections.

4.2 WATER QUANTITY

As noted previously, it is required that the post-development discharge rate from the site match pre-development levels for the 2- to 100-year storm events for Solandt Road, and match the 310 L/s 100-year pond release rate indicated in the Certificate of Approval.

Proposed features to achieve these targets include:

- Roof storage with flow control roof drains
- Pond grading and weir reconfiguration

PCSWMM software has been used to model the behaviour of the proposed SWM system and determine its response under various storm events. The model was developed and tested in an iterative manner to determine the necessary storage volumes and flow control rates from the two proposed buildings. Roof storage areas were defined using storage nodes in the model, with appropriate stage-storage relationships based on the volumes available in each area. Outflow controls from each storage node were defined using outlets with appropriate head-discharge curves as defined using manufacture information provided in **Appendix E**.

A summary of the modeling results is provided in Table 5 and Table 6, detailed PCSWMM modeling results are provided in **Appendix C**.

The model was developed assuming 90% of the roof area is available for storage, as shown on the roof plan, discharge from Building A and Building B will be controlled by 18 and 15 WATTS Adjustable Flow Control Roof Drains (or equivalent) respectively.

Table 5: Pre vs Post Development Flow Rates

OUTFALL	PEAK FLOW RATE (m ³ /sec)					
	2-yr	5-yr	10-yr	25-yr	50-yr	100-yr
Existing Conditions						
OF1 – Solandt Rd	0.22	0.33	0.40	0.50	0.58	0.66
OF2 – Kizell Drain	-	-	-	-	-	0.31
Proposed Conditions						
OF1 – Solandt Rd	0.23	0.33	0.40	0.49	0.56	0.64
OF2 – Kizell Drain	0.085	0.133	0.172	0.226	0.267	0.310

Table 6: PCSWMM Modeling Results

RETURN PERIOD (Years)	BUILDING A			BUILDING B		
	ROOF STORAGE UTILIZED (m ³)	ROOF PONDING DEPTH (mm)	ROOF STORAGE AVAILABLE (m ³)	ROOF STORAGE UTILIZED (m ³)	ROOF PONDING DEPTH (mm)	ROOF STORAGE AVAILABLE (m ³)
2	186	172	1148	110	152	581
5	275	198		163	176	
10	337	214		200	190	
25	416	230		248	206	
50	477	242		285	217	
100	541	253		324	227	

As shown in Table 6, there is a maximum roof ponding depth of 253 mm and 227 for buildings A and B respectively during the full range of storm events and there is sufficient storage volume available on both roofs to store up to and including the 100-yr event. The available storage volume was calculated as the volume available below the overflow scuppers (340 mm and 290 mm above the roof drains for Building A and B respectively).

4.2.1 EXISTING WET POND

As previously discussed, there is an existing wet pond in the north-east corner of the site. A Phase 1 Environmental Site Assessment completed by SRL in April 2021 determined that the existing wet pond is approximately 1 m deep and noted some additional ponding in the area around the pond as shown on Figure 5. It should be noted that the existing ponding area adjacent to the pond will be regraded in proposed conditions to promote positive drainage towards the wet pond and reduce risk of flooding the adjacent property. Detailed survey information found the pond to have an approximately 1,868 m² area at the top of the permanent pool and a top of water elevation of approximately 76.1 m at the time of the survey. The existing pond will be dredged to ensure the required permanent pool volume for quality control is achieved as described in Section 4.3.

A survey of the outlet structure found that the metal plate containing a trapezoidal weir and rectangular opening had been lifted. It was assumed that this plate was designed to be down in existing conditions, with the permanent pool elevation at 76.09 m. A new weir configuration is proposed so that the target release rate of 310 L/s is achieved in post-development conditions (Figure 4). Discharge from the pond flows into a v-ditch and into the Kizell Drain as shown on the MVCA Floodplain Map in **Appendix D**.

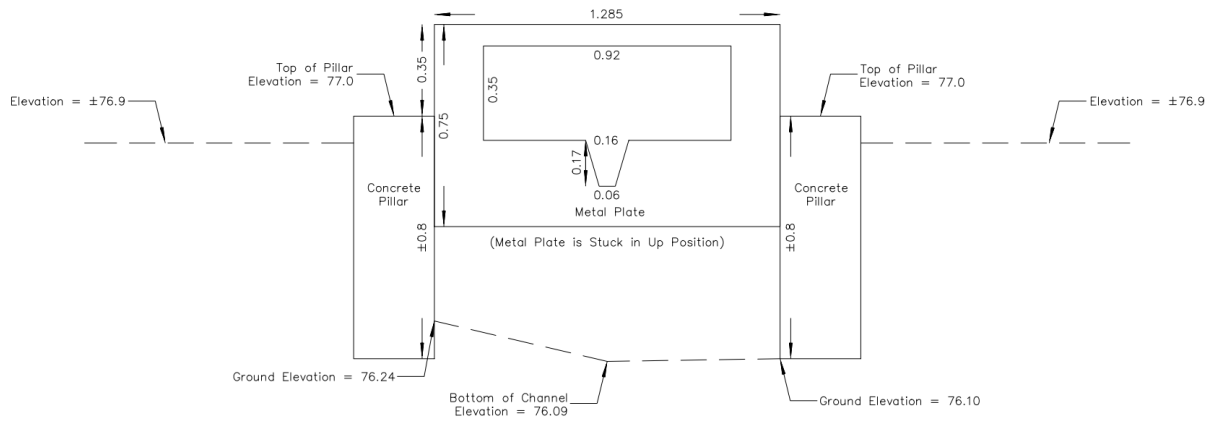

Figure 3: Existing pond outlet structure

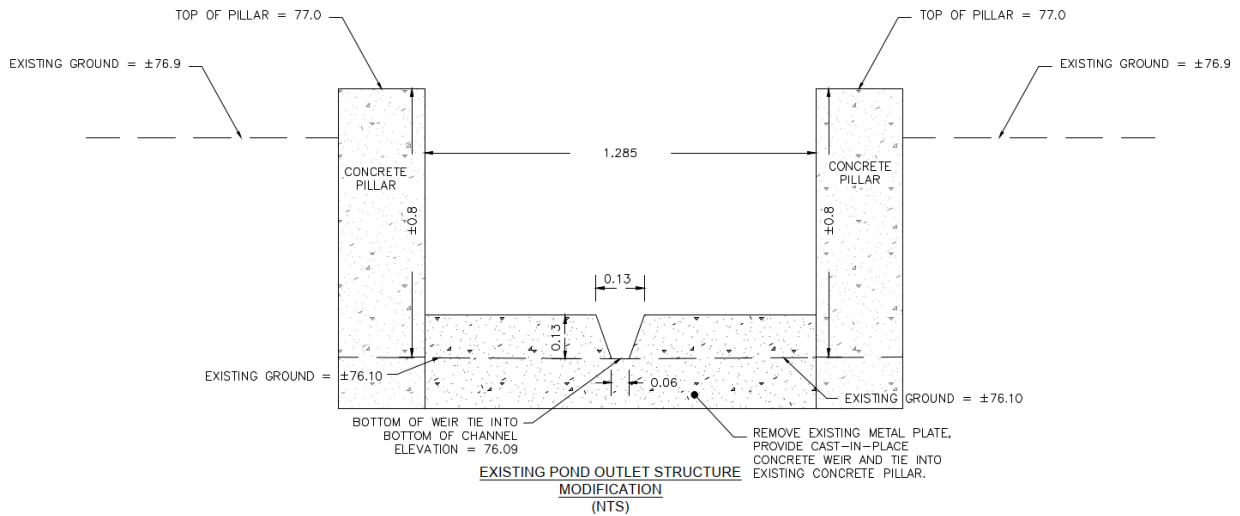

Figure 4: Proposed pond outlet structure

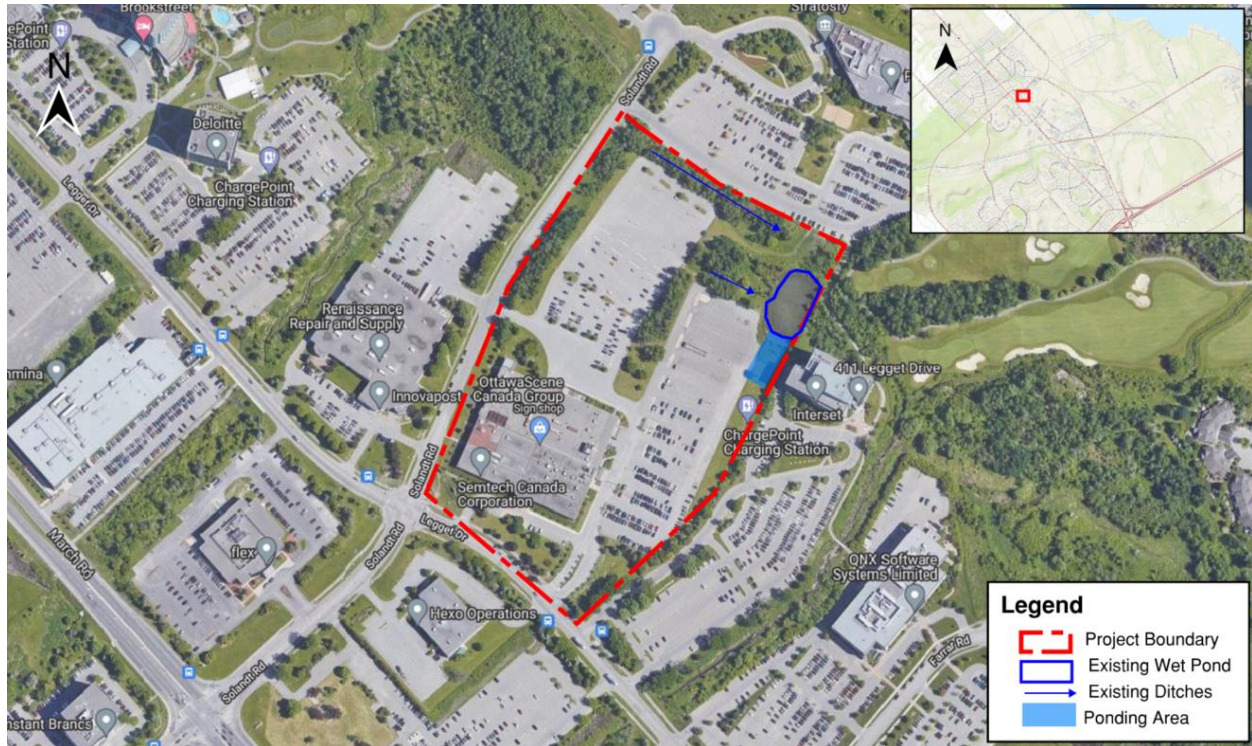

Figure 5: Existing Drainage

A summary of the modeling results showing expected high-water elevations and maximum storage volumes in the pond in proposed conditions is shown in Table 7. Detailed modeling results can be found in **Appendix C**.

Table 7: Proposed Condition PCSWMM Results - Wet Pond

RETURN PERIOD	2-YR	5-YR	10-YR	25-YR	50-YR	100-YR	100-YR+20%	100-YR FIXED TAILWATER*
Active Storage Volume (m ³)	527	656	754	886	986	1093	1324	1705
Total Storage Volume (m ³)	2153	2282	2380	2512	2612	2719	2950	3331
Maximum Water Elevation (m)	76.33	76.37	76.41	76.44	76.47	76.5	76.55	76.63
Pond Outflow (m ³ /s)	0.085	0.133	0.172	0.226	0.267	0.310	0.401	0.439

*See Section 4.4

Surface ponding occurs in the northeast corner and remains well below the existing finished floor elevation of 78.60 m. The proposed condition finished floor elevations are 78.50 m and 77.65 m for Buildings A and B respectively. The proposed 100-year ponding elevation is greater than 1 m below the lowest finished floor elevation. Therefore, the design criteria have been met and there is sufficient volume available to prevent flooding.

4.3 WATER QUALITY

As noted previously, the majority of site runoff will continue to drain to the existing wet pond on site and ultimately discharge into the Kizell Drain.

It is assumed that runoff from the proposed rooftop areas and walkways areas will be free of typical sediment-generating activities and can therefore be considered clean for the purposes of water quality assessment. It should be noted that the typical sediment-generating activities are in areas with vehicular access, such as loading areas and

parking areas. In the case of this development, the overall parking area is reduced and replaced with the roof areas of the proposed buildings. Therefore, the overall water quality leaving the site is improved compared to existing conditions.

The existing wet pond will provide quality control for the site. Using Table 3.2 from the MOE 2003 Stormwater Planning and Design Manual, the required total storage, extended detention, and permanent pool volumes were calculated. The total area draining to the wet pond is 6.00 ha, with an imperviousness of 63%. Based on MOE 2003 Table 3.2, a total storage volume of 1252 m³ is required, with 1012 m³ being permanent pool and 240 m³ being extended detention during the water quality event (see Table 9).

During construction, the existing pond will be dredged so that the required permanent pool volume is achieved. Once this is complete, the pond will provide sufficient permanent pool, extended detention, and drawdown time to achieve an enhanced level of treatment.

Table 8: MOE 2003 SWM Planning and Design Manual Table 3.2

Protection Level	SWMP Type	Storage Volume (m ³ /ha) for Impervious Level			
		35%	55%	70%	85%
<i>Enhanced</i> 80% long-term S.S. removal	Infiltration	25	30	35	40
	Wetlands	80	105	120	140
	Hybrid Wet Pond/Wetland	110	150	175	195
	Wet Pond	140	190	225	250

Table 9: Wet Pond Water Quality Calculations

PARAMETER	REQUIRED	PROVIDED
Total Storage Volume	209 m ³ /ha = 1252 m ³	3335 m ³
Extended Detention Volume	40 m ³ /ha = 240 m ³	279 m ³
Permanent Pool Volume	1252 m ³ – 240 m ³ = 1012 m ³	1626 m ³
Drawdown Time	24 hours	72 hours

The above table demonstrates that the existing wet pond provides sufficient quality control to meet the target of enhanced (80% TSS removal) treatment.

4.4 FLOODPLAIN CONSIDERATIONS

A flood plain map was provided by the MVCA and is included in **Appendix D**. As shown on the map, the proposed development is outside of both the Kizell Drain and Shirley's Brook 1:100-year floodplain and therefore loss of floodplain storage is not a concern in the case of this development.

Based on the MVCA floodplain map, the 100-year flood elevation of the Kizell drain near the pond outlet is approximately 76.5 m. The proposed model was run with this fixed tailwater condition to assess the improbable scenario that the peak 100-year discharge from the site is coincident with the peak 100-year flow in the Kizell Drain. In this scenario, the maximum pond elevation is 76.63 m. This flood elevation remains well below the finished floor elevations of 78.50 m and 77.65 m for Buildings A and B respectively.

4.5 TEMPERATURE CONSIDERATIONS

Proposed enhanced grass swales as well as the vegetation surrounding the existing pond help to cool runoff as it passes along / through naturally vegetated media and infiltrate flows from asphalt surfaces. Furthermore, existing trees around the wet pond further cool water within the pond.

In conjunction, the above measures are considered sufficient to address MVCA requirements related to temperature of storm runoff from the site.

4.6 MAINTENANCE CONSIDERATIONS

Proper maintenance of the SWM pond is necessary to ensure it continues to function as designed. Additional requirements may be prescribed as a result of the pending ECA amendment.

INSPECTION

Inspection of a stormwater management facility is performed to determine if the facility is functioning as designed, and to determine what is required in terms of maintenance. A visual inspection of the facility and surrounding area should take place after major storm events. It is recommended that visual inspection of the facility be carried out after three days without rain, at which time the facility should be at its normal water level.

The inspections should include observations of the items listed below. Results of the inspections should be recorded so that they can be referred to when scheduling follow-up maintenance.

- Water Level: Determine if water level is at, above, or below the permanent pool elevation of 76.09 m.
- Inlets/Outlets: Visually inspect inlets and outlets for blockage, erosion, or debris.
- Erosion Protection: Visually inspect erosion protection measures such as rip-rap at the inlet and outlet.
- Concrete structure: Visually inspect concrete outlet structure for cracks. Cracks should be photographed and documented for future inspections.
- Sediment depth: Sediment depth in the pond should be measured annually and documented.

MAINTENANCE

In order to ensure that the stormwater management facility continues to provide long-term quality, erosion, and flood control benefits, maintenance on a regular basis should be scheduled and implemented. The tasks listed below should be incorporated into the maintenance schedule.

- Trash removal: Trash should be removed from the pond, outlet, and area around the pond annually.
- Debris removal: Debris should be removed from the inlet and outlet at each inspection. Any object with the potential to cause future blockage should be removed.

- Sediment removal: Periodic sediment removal from the pond is required to maintain water quality treatment capacity. It is estimated that sediment removal will be required approximately every 30 years (MOE SWM Planning and Design Manual Figure 6.3). Sediment removal should occur when the permanent pool volume reaches 70% of the design volume.

5 CONCLUSIONS

A stormwater management report has been prepared to support the feasibility study for the proposed development at 415 Legget Drive in the City of Ottawa. The key points are summarized below.

WATER QUALITY

The existing stormwater management wet pond is considered sufficient to meet the quality control requirements for the site. The pond will be dredged during construction to ensure the required permanent pool volume is provided.

WATER QUANTITY

Quantity control will be provided via roof storage on the two proposed buildings, controlled with flow control roof drains. The existing wet pond with a new outlet structure will provide additional flow control to meet the target release rate of 310 L/s.

APPENDIX

A

PRE-CONSULTATION
MEETING MINUTES
AND TECHNICAL
COMMENTS

Pre-Application Consultation Meeting Notes

11:00am to 12:00pm, September 27, 2021, via Microsoft Teams
Property Address: 415 Legget Drive and 2700 Solandt Road
File No.: PC2021-0327

Attendees:

Molly Smith – Planner, City of Ottawa
Matthew Ippersiel – Planner (Urban Design), City of Ottawa
Matthew Hayley – Planner (Environmental), City of Ottawa
Jeffrey Ren – Co-op Student, City of Ottawa
Jill MacDonald – WSP
Justyna Garbos – WSP
Survir Pursnani – WSP
Jie Chen – Architecture49
Frank Abrantes – Access Storage
Hind Barnieh – Access Storage

Regrets:

Mark Richardson – Forester, City of Ottawa
Neeti Paudel – Project Manager (Transportation), City of Ottawa
Jessica Valic – Project Manager (Infrastructure), City of Ottawa
Jeff Goettling – Planner (Parks), City of Ottawa

Applicant's Proposal:

- The proposed development will be split into two phases – the first phase is interior retrofit of the existing building and the second phase is the construction of the two new warehouse buildings in the current parking lot
- The new buildings will be between 24 and 36 feet in height
- A total of 176 surface level parking spaces will be provided
- Access to the proposed development will be via the three existing accesses from Legget Drive and Solandt Road
- No minor variance being sought; the applicants expect that the proposed development conforms to the Zoning By-law.
- The applicant is targeting a submission on or before October 27

Preliminary comments and questions from staff and agencies, including follow-up actions:

Infrastructure

Water

Available Watermain

- 305mm (DI) – Legget Dr (existing 250mm service is located off this main)
- 305mm (PVC) – Solandt Rd

- Per WDG 4.3.1, where basic demand is greater than 50 m³/day, there shall be a minimum of two water services, separated by an isolation valve, to avoid creation of vulnerable service area.
- Per WDG 4.4.7.2, District Meter Area (DMA) Chamber is required for services greater than 150mm in diameter.
- Only one water service is permitted per parcel. Servicing for additional buildings must be accomplished through internal branching of existing water service. If larger water service is required to accommodate additional development, please utilize the location of the existing service to limit cuts in watermain. If a new service is required, and existing location cannot be used, the existing service must be blanked at the main
- Demonstrate that the water service is adequately sized for increased water use.
- Demonstrate that adequate fire flow from fire hydrants and required pressures per City of Ottawa Water Design Guidelines are available. Provide fire hydrant coverage plan.

Boundary Conditions

Request prior to first submission. Contact assigned City Infrastructure Project Manager with the following information

- Location of service(s)
- Type of development
- Fire flow (per FUS method – include FUS calculation sheet with boundary condition request – boundary conditions will not be requested without fire flow calculations)
- Average Daily Demand (l/s)
- Maximum Hourly Demand (l/s)
- Maximum Daily Demand (l/s)

Sanitary

Available Sanitary Sewer

- 750mm (CONR) – Legget Dr – Marchwood Collector
- No available sanitary main on Solandt Rd
- Connections to collector sewers are discouraged. It is assumed that the existing building sanitary service is connected to this collector sewer. Reuse existing connection location to limit cuts in sanitary sewer.
- Demonstrate that the existing sanitary service is adequately sized for increased flow.
- Demonstrate that there is sufficient/adequate residual capacity in the receiving system to accommodate increase in flow
- Provided the existing service is adequately sized, please CCTV existing lateral to determine the condition of the lateral and submit CCTV video and report with application. If service is in poor condition, repair/replacement will be required.

Storm

Available Storm Sewer

- 525mm (CONC) – Solandt Rd
- 375mm (PVC) – Legget Dr

Stormwater Management

- Quantity Control
 - Required for the site up to and including the 100-yr storm event.
 - Refer to Shirley's Brook and Watts Creek Subwatershed Study Report for relevant environmental protection targets.
 - Consult Stormwater Management Plan, Kanata Research Park, City of Kanata for relevant stormwater management criteria.
 - Existing ditch system and wet pond exist on site.
 - If underground/inline stormwater storage is proposed, an average release rate equal to 50% of the determined peak allowable rate must be used. Otherwise, disregard the underground/inline storage as available storage or provide modeling to support the proposed design. The reasoning for this restriction is that the discharge rate at full storage is not representative of the discharge rate for more frequent storm events. Halving the discharge rate compensates for the inaccuracies of the modified rational method when underground storage is used.
 - Provide both pre and post development stormwater management plans, showing individual drainage areas and their respective coefficient.
 - If roof storage is proposed, please provide a roof drainage plan showing the 5 and 100-year storm ponding levels. Include the roof drain type, opening settings, and flow rate.
 - Per Technical Bulletin PIEDTB-2016-01 section 8.3.11.1 there shall be no surface ponding on private parking areas during the 2-year storm rainfall event.
 - Please note that the minimum orifice dia. for a plug style ICD is 83mm and the minimum flow rate from a vortex ICD is 6 L/s in order to reduce the likelihood of plugging.
- Quality Control: Please consult Conservation Authority (CA) regarding water quality control restrictions for the subject site. Include correspondence in servicing report.
- Ministry of Environment, Conservation, and Parks (MECP): Designer to determine if approval for sewage works under Section 53 of OWRA is required and to determine the type of application required. Reviews will be done through Transfer of Review or Direct Submission.
- Stormwater drainage systems that are designed to accommodate drainage from two separate parcels require an ECA.

Geotechnical Investigation

- Geotechnical Report is required for this development proposal.
- The Geotechnical Report shall speak to any proposed underground stormwater storage and provide confirmation that the site subsurface characteristics (groundwater table elevation, soil type) are appropriate. Of note, the high groundwater table must be 1.0m above the bottom of any proposed storage system per MECP requirements.

Exterior Lighting

- If exterior light fixtures are proposed, provide a plan showing the location of all exterior fixtures and include a table providing fixture details (make, model, mounting heights). All external light fixtures must meet the criteria for full cut-off classification as recognized by the Illuminating Engineering Society of North America (IESNA or IES), resulting in minimal light spillage onto

adjacent properties (as a guideline, 0.5 fc is normally the maximum allowable spillage). Provide certification letter from a relevant Professional Engineer.

Required Studies

- Servicing/Stormwater Management Report (Submit completed Servicing Study Checklist with Servicing Report)
- Geotechnical Investigation

Required Plans

- Site Servicing Plan
- Grade Control and Drainage Plan (Show major overland flow route)
- Erosion and Sediment Control Plan (Can be combined with grading plan)
- Existing Conditions and Removals Plan
- SWM Plans

General Information

1. The Servicing Study Guidelines for Development Applications are available at the following address: <https://ottawa.ca/en/city-hall/planning-and-development/information-developers/development-application-review-process/development-application-submission/guide-preparing-studies-and-plans#servicing-study-guidelines-development-applications>
2. Servicing and site works shall be in accordance with the following documents:
 - Ottawa Sewer Design Guidelines (October 2012) (including subsequent Technical Bulletins)
 - Ottawa Design Guidelines – Water Distribution (2010) (including subsequent Technical Bulletins)
 - Geotechnical Investigation and Reporting Guidelines for Development Applications in the City of Ottawa (2007)
 - Ottawa Standard Tender Documents (latest version)
3. Record drawings and utility plans are also available for purchase from the City (Contact the City's Information Centre by email at InformationCentre@ottawa.ca or by phone at (613) 580-2424 x.44455).
4. Any proposed work in utility easements requires written consent of easement owner.
5. **All submitted report and plan pdf documents to be flattened and unsecured to allow for editing and ease of use.**
6. All documents prepared by Engineers shall be signed and dated on the seal.

Please contact Infrastructure Project Manager Jessica Valic (jessica.valic@ottawa.ca) for follow-up questions.

Planning

- The application will be considered Site Plan Control (Manager Approval, Public Consultation), please fine the application form and information on fees [here](#).
- Please review the following Official Plan policies and Zoning By-law provisions:

- The subject site is designated as [Urban Employment Area](#) in the Official Plan
- The subject site is zone [Business Park Industrial Zone, Subzone 6 – Kanata North Business Park \(IP6\)](#).
- The New Official Plan will be going to Planning Committee on October 14, 2021 and then to City Council for adoption on October 27, 2021 – please be aware of the following New Official Plan policies:
 - The subject site is designated as ‘Kanata North Economic District’ with an ‘Evolving Neighbourhood’ overlay; policies for the ‘Kanata North Economic District’ can be found under [Section 6.6.3.2 of the revised draft New Official Plan](#).
 - Please provide a review and summary of the designation and applicable policies as they apply to the site.
 - The ‘Kanata North Economic District’ is expected to be the site of a Community Planning Permit System pilot project – the pilot project would require the passage of a Community Planning Permit System by-law after the New Official Plan comes into effect.
 - A complete application is received by no later than the day before the new Official Plan is adopted (October 27, 2021), it will be processed on the basis of existing Official Plan policy provided it is consistent with the 2020 Provincial Policy Statement.
 - Applications received after the day before the new Official Plan is adopted will be reviewed and evaluated on the basis of the policies of the new Official Plan.
 - Based on the submitted concept plan and the draft New Official Plan available at the time of the pre-consultation meeting, the proposed development does not appear to be affected by any proposed policy changes.
- Please consider providing only the minimum number of required parking spaces.
- Please consider relocating the parking spaces between the right-of-way and the existing building.
- Please incorporate additional landscaping throughout the parking lot through the introduction of additional parking lot islands and along the perimeter of the property where sidewalks would be found.
- Please ensure that all landscaping provisions for parking lots are being followed; please refer to Section 110 of the Zoning By-law.
- Please provide shaded landscaped pedestrian connections from the public sidewalk to building entrances.
- For bicycle parking, consider providing covered shelters for bicycle parking or integrate within buildings.
- Please refrain from designing blank walls along the street frontages; buildings should be street-oriented with entrances facing the street with highly transparent ground-floor facades.
- Please consider integrating pedestrian-oriented features such as shade trees, bicycle/scooter parking, outdoor seating areas and street furniture.
- Please ensure that the proposed development complies with all applicable provisions of the Zoning By-law and provide a comprehensive zoning table on the submitted site plan and report.
- Please note that Councillor Jenna Sudds has resigned as Councillor for Kanata North (Ward 4) – please reach out to her successor when applicable.
 - City Council will be declaring the office vacant and staff will recommend that City Council approve interim delegations of authority with respect to Ward 4 matters on

October 13, 2021, Council will then appoint person to fill the vacancy or hold a by-election.

- The application will be subject to public consultation (conducted through the posting of on-site signage, the notification of community groups, and through the City of Ottawa's DevApps website); please note that the Councillor may also ask for a Community Information and Comment Session.
- Please determine if Section 37 applies.

Urban Design

- Specific Design Comments
 - Avoid blank walls facing the public realm. Integrate as much glazing, transparency, entrances and active frontages as possible facing Legget and Solandt, particularly at the ground floor.
 - Integrate a generous landscaping treatment along Solandt that is in keeping with the character of Kanata Business Park. This often includes coniferous species of trees.
 - Consider opportunities for pedestrian-oriented features such as shade trees, bicycle/scooter parking, outdoor seating areas and street furniture
 - To minimize the impact on the public realm, service areas such as parking, loading, vehicle access and service entrances should be at the rear of the buildings. Use landscaping to screen them from the public realm.
 - Where exposed to the public realm, use landscaping to screen parking lots as much as possible.
 - Integrate as much greening into the parking lot as possible and ensure strong and logical pedestrian connectivity to building entrances.
- New Official Plan (New OP) – Note that the draft new OP aims to designate the greater area that this property falls within as a “Special Economic District” and as a Design Priority Area. The new policy will aim to enhance mobility options, encourage mixed-use development and promote enhanced urban design. Please refer to [Section 6.6.3.2](#) of the draft plan. Though not currently in effect, the proponent is strongly encouraged to implement the new vision for the area as much as possible.
- Kanata North Tech Park Community Planning Permit Pilot Study (CPP) – Note that a study is currently underway for the greater area that this property falls within, which will have implications for urban design. It is being re-envisioned as a “highly-connected, vibrant mixed-use area where people live, work, connect and play”. Refer to the project [Website](#) for more details.
- Design Brief – As part of your submission, please include a Design Brief. Please refer to the attached Design Brief Terms of Reference to inform the content of the brief.
- Urban Design Review Panel – In the current policy context, this application is not subject to review by the Urban Design Review Panel (UDRP). While the draft new Official Plan aims to recognize the area as a Design Priority Area, early indications from staff working on the Kanata

North CPP are that the area will likely be exempt from review by the UDRP (though it is possible that this may be subject to change).

Please contact Urban Design Planner Matthew Ippersiel (Matthew.Ippersiel@ottawa.ca) for follow-up questions.

Environmental Planning

Bird-safe Design

- Given the height of the proposal (mid to high rise) the proposal will need to review and incorporate bird safe design elements. Some of the risk factors include glass and related design traps such as corner glass and fly-through conditions, ventilation grates and open pipes, landscaping, light pollution. More guidance and solutions are available in the guidelines which can be found here: <https://ottawa.ca/en/planning-development-and-construction/developing-property/development-application-review-process/development-application-submission/guide-preparing-studies-and-plans> .

Environmental Impact Statement (EIS) to address species at risk and provide recommendations on wildlife mitigations.

- Blanding's turtles sighted in the area, indicating regulated habitat may be present on the property, particularly in the parts around the pond. MECP consultation will likely be required to address the limits of Blanding's turtle habitat and to obtain the necessary approvals.

Please contact Environmental Planner Matthew Hayley (Matthew.Hayley@ottawa.ca) for follow-up questions.

Forestry

- A Tree Conservation Report (TCR) must be supplied for review along with the suite of other plans/reports required by the City
 - a. an approved TCR is a requirement of Site Plan approval.
 - b. The TCR may be combined with the Landscape Plan provided all information is supplied.
- As of January 1 2021, any removal of privately-owned trees 10cm or larger in diameter, or publicly (City) owned trees of any diameter requires a tree permit issued under the Tree Protection Bylaw (Bylaw 2020 – 340); the permit will be based on an approved TCR and made available at or near plan approval.
- The Planning Forester from Planning and Growth Management as well as foresters from Forestry Services will review the submitted TCR.
 - a. If tree removal is required, both municipal and privately-owned trees will be addressed in a single permit issued through the Planning Forester.
 - b. Compensation may be required for city owned trees – if so, it will need to be paid prior to the release of the tree permit.
- The TCR must list all trees on site, as well as off-site trees if the CRZ extends into the developed area, by species, diameter and health condition.
- Please identify trees by ownership – private onsite, private on adjoining site, city owned, co-owned (trees on a property line).
- The TCR must list all trees on adjacent sites if they have a critical root zone that extends onto the development site.

- If trees are to be removed, the TCR must clearly show where they are, and document the reason they cannot be retained.
- All retained trees must be shown and all retained trees within the area impacted by the development process must be protected as per City guidelines available at [Tree Protection Specification](#) or by searching Ottawa.ca.
 - a. The location of tree protection fencing must be shown on a plan
 - b. Show the critical root zone of the retained trees
 - c. If excavation will occur within the critical root zone, please show the limits of excavation
- The City encourages the retention of healthy trees; if possible, please seek opportunities for retention of trees that will contribute to the design/function of the site.
- For more information on the process or help with tree retention options, contact Mark Richardson mark.richardson@ottawa.ca or on [City of Ottawa](#).

Landscape Plan tree planting requirements:

For additional information on the following please contact tracy.smith@Ottawa.ca

Minimum Setbacks

- Maintain 1.5m from sidewalk or MUP/cycle track.
- Maintain 2.5m from curb
- Coniferous species require a minimum 4.5m setback from curb, sidewalk or MUP/cycle track/pathway.
- Maintain 7.5m between large growing trees, and 4m between small growing trees. Park or open space planting should consider 10m spacing.
- Adhere to Ottawa Hydro's planting guidelines (species and setbacks) when planting around overhead primary conductors.

Tree specifications

- Minimum stock size: 50mm tree caliper for deciduous, 200cm height for coniferous.
- Maximize the use of large deciduous species wherever possible to maximize future canopy coverage
- Tree planting on city property shall be in accordance with the City of Ottawa's Tree Planting Specification; and include watering and warranty as described in the specification (can be provided by Forestry Services).
- Plant native trees whenever possible
- No root barriers, dead-man anchor systems, or planters are permitted.
- No tree stakes unless necessary (and only 1 on the prevailing winds side of the tree)

Hard surface planting

- Curb style planter is highly recommended
- No grates are to be used and if guards are required, City of Ottawa standard (which can be provided) shall be used.
- Trees are to be planted at grade

Soil Volume

- Please ensure adequate soil volumes are met:

Tree Type/Size	Single Tree Soil Volume (m3)	Multiple Tree Soil Volume (m3/tree)
Ornamental	15	9
Columnar	15	9
Small	20	12
Medium	25	15
Large	30	18
Conifer	25	15

Please note that these soil volumes are not applicable in cases with Sensitive Marine Clay.

Sensitive Marine Clay

- Please follow the City's 2017 Tree Planting in Sensitive Marine Clay guidelines

Please contact Planning Forester Mark Richardson (Mark.Richardson@ottawa.ca) for follow-up questions.

Transportation

- Follow Traffic Impact Assessment Guidelines
 - Proceed with scoping.
 - Start this process asap.
 - Applicant advised that their application will not be deemed complete until the submission of the draft step 1-4, including the functional draft RMA package (if applicable) and/or monitoring report (if applicable). Collaboration and communication between development proponents and City staff are required at the end of every step in the TIA process
 - Request base mapping asap if RMA is required. Contact Engineering Services (<https://ottawa.ca/en/city-hall/planning-and-development/engineering-services>)
- Noise Impact Studies required for the following:
 - Stationary (if, within 100m of noise sensitive land use).
- Ensure clear throat length requirements as per TAC are met at the accesses.
- The easterly access on Legget Drive does not meet the private approach guidelines. This may have to be reconfigured and will be further reviewed in the TIA.
- On site plan:
 - Show all details of the roads abutting the site up to and including the opposite curb; include such items as pavement markings, accesses and/or sidewalks.
 - Turning templates will be required for all accesses showing the largest vehicle to access the site; required for internal movements and at all access (entering and exiting and going in both directions).
 - Show all curb radii measurements; ensure that all curb radii are reduced as much as possible
 - Grey out any area that will not be impacted by this application.

- As the proposed site is industrial and for general public use, AODA legislation applies. Consider using the City's Accessibility Design Standards.
- Number of accessible parking spaces should meet the requirements from Table 3 of the City's accessible Design Standards.
- Site triangles at the following locations on the final plan will be required:
 - Collector Road to Collector Road: 5 metre x 5 metres
- The scoping and forecasting can be submitted together and should be done as soon as possible.

Please contact Transportation Project Manager Neeti Paudel (Neeti.Paudel@ottawa.ca) for follow-up questions.

Parks

- How will the proposal meet the Parkland Dedication (By-law No. 2009-95)?
- For commercial and industrial purposes, the parkland requirement is calculated as 2% of the gross land area of the site being developed.
- The conveyance of land for purposes or the payment of money in-lieu of accepting the conveyance is not required for development, redevelopment, subdivisions or consents, where it is known, or can be demonstrated that the required parkland conveyance or money in-lieu thereof has been previously satisfied.

Please contact Parks Planner Jeff Goettling (Jeff.Goettling@ottawa.ca) for follow-up questions.

Other

Please refer to the links to the [guide to preparing studies and plans](#) and [development application fees](#) for general information. Additional information is available related to [building permits](#), [development charges](#), and [the Accessibility Design Standards](#). Be aware that other fees and permits may be required, outside of the development review process. You may obtain background drawings by contacting informationcentre@ottawa.ca.

These pre-consultation comments are valid for one year. If you submit a development application(s) after this time, you may be required to meet for another pre-consultation meeting and/or the submission requirements may change. You are as well encouraged to contact us for a follow-up meeting if the plan/concept will be further refined.



Ministry
of the
Environment

Ministère
de
l'Environnement

CERTIFICATE OF APPROVAL
INDUSTRIAL SEWAGE WORKS
NUMBER 0147-6CKGJG

415 Legget Leaseholds Inc.
150 King Street West, Suite 2103 , Box 40
Toronto, Ontario
M5H 3Z7

Site Location: 415 Legget Drive
Ottawa City

You have applied in accordance with Section 53 of the Ontario Water Resources Act for approval of:

the establishment of sewage works for the collection, transmission, treatment and disposal of stormwater run-off, to provide normal water quality protection and to attenuate post-development peak flows to pre-development levels, for all storm events up to and including the 100-year return storm, consisting of the following:

- one (1) stormwater management pond with a permanent pool of approximately 520 cubic metres and a total active storage volume of approximately 1,171 cubic metres for the 100-year return storm discharging at the rate of approximately 310 litres per second, with the outlet structure consisting of multistage weir which outlets to Kizzell Drain; the pond being equipped with riprap overflow spillway.

all in accordance with the Application for Approval of Industrial Sewage Works submitted by Greg Spafford, Vice President of 415 Legget Leaseholds Inc. dated April 11, 2005 and all supporting information.

For the purpose of this Certificate of Approval and the terms and conditions specified below, the following definitions apply:

"certificate" means this entire certificate of approval document, issued in accordance with Section 53 of the *Ontario Water Resources Act*, and includes any schedules;

"Director" means any Ministry employee appointed by the Minister pursuant to section 5 of the *Ontario Water Resources Act*;

"District Manager" means the District Manager of the Ottawa District Office of the Ministry;

"Ministry" means the Ontario Ministry of the Environment;

"Owner" means 415 Legget Leaseholds Inc. and includes its successors and assignees; and

"works" means the sewage works described in the Owner's application, this certificate and in the supporting documentation referred to herein, to the extent approved by this certificate.

You are hereby notified that this approval is issued to you subject to the terms and conditions outlined below:

TERMS AND CONDITIONS

1. GENERAL CONDITION

(1) Except as otherwise provided by these Conditions, the Owner shall design, build, install, operate and maintain the works in accordance with the description given in this Certificate, the application for approval of the works and the submitted supporting documents and plans and specifications as listed in this Certificate.

(2) Where there is a conflict between a provision of any submitted document referred to in this Certificate and the Conditions of this Certificate, the Conditions in this Certificate shall take precedence, and where there is a conflict between the listed submitted documents, the document bearing the most recent date shall prevail.

2. OPERATION AND MAINTENANCE

(1) The Owner shall undertake an inspection of the condition of the works, at least once a year, and undertake any necessary cleaning and maintenance to prevent excessive buildup of sediment and vegetation.

(2) The owner shall maintain a logbook to record the results of these inspections and any cleaning and maintenance operations undertaken and shall keep the logbook at the site for inspection by the Ministry.

3. EXPIRY OF APPROVAL

The approval issued by this Certificate will cease to apply to those parts of the Works which have not been constructed within five (5) years of the date of this Certificate.

4. CHANGE OF OWNER

4.1 The Owner shall notify the District Manager, in writing, of any of the following changes within 30 days of the change occurring:

(a) change of Owner;

(b) change of partners where the Owner is or at any time becomes a partnership, and a copy of the most recent declaration filed under the Business Names Act, R.S.O. 1990, c.B17 shall be included in the notification to the District Manager;

(c) change of name of the corporation where the Owner is or at any time becomes a corporation, and a copy of the most current information filed under the Corporations Information Act, R.S.O. 1990, c. C39 shall be included in the notification to the District Manager.

5. RECORD KEEPING

5.1 The Owner shall prepare operational manual which should include, but not limited to, frequency and method of clean-out of stormwater management works within six (6) months from the date of issuance of this Certificate of Approval or the commissioning of the Works. The Owner shall keep the operations manual up to date with such revisions as may be required. Upon request, the Owner shall make the manual available for inspection by Ministry personnel and furnish a copy to the Ministry.

5.2 The Owner shall maintain a logbook to record the results of all inspections and any cleaning and maintenance operations undertaken and shall make the logbook available for inspection by the Ministry upon request.

5.3 The Owner shall retain for a minimum period of five (5) years from the date of their creation all records and information related to or resulting from the monitoring activities required by this certificate.

The reasons for the imposition of these terms and conditions are as follows:

1. Condition 1 is imposed to ensure that the works are built and operated in the manner in which they were described for review and upon which approval was granted. This condition is also included to emphasize the precedence of Conditions in the Certificate and the practice that the Approval is based on the most current document, if several conflicting documents are submitted for review.

2. Condition 2 is included to ensure that any build-up of sediment does not impair the performance of the works.

3. Condition 3 is included to ensure that, when the Works are constructed, the Works will meet the standards that apply at the time of construction to ensure the ongoing protection of the environment.

4. Condition 4 is included to ensure that the Ministry records are kept accurate and current.

5. Condition 5 is included to provide a performance record for future references, to ensure that the Ministry is made aware of problems as they arise, and to provide a compliance record for all the terms and conditions outlined in this Certificate, so that the Ministry can work with the Owner in resolving any problems in a timely manner.

In accordance with Section 100 of the Ontario Water Resources Act, R.S.O. 1990, Chapter 0.40, as amended, you may by written notice served upon me and the Environmental Review Tribunal within 15 days after receipt of this Notice, require a hearing by the Tribunal. Section 101 of the Ontario Water Resources Act, R.S.O. 1990, Chapter 0.40, provides that the Notice requiring the hearing shall state:

1. The portions of the approval or each term or condition in the approval in respect of which the hearing is required, and;
2. The grounds on which you intend to rely at the hearing in relation to each portion appealed.

The Notice should also include:

3. The name of the appellant;
4. The address of the appellant;
5. The Certificate of Approval number;
6. The date of the Certificate of Approval;
7. The name of the Director;
8. The municipality within which the works are located;

And the Notice should be signed and dated by the appellant.

This Notice must be served upon:

The Secretary*
Environmental Review Tribunal
2300 Yonge St., 12th Floor
P.O. Box 2382
Toronto, Ontario
M4P 1E4

AND

The Director
Section 53, *Ontario Water Resources Act*
Ministry of the Environment
2 St. Clair Avenue West, Floor 12A
Toronto, Ontario
M4V 1L5

*** Further information on the Environmental Review Tribunal's requirements for an appeal can be obtained directly from the Tribunal at: Tel: (416) 314-4600, Fax: (416) 314-4506 or www.ert.gov.on.ca**

The above noted sewage works are approved under Section 53 of the Ontario Water Resources Act.

DATED AT TORONTO this 27th day of May, 2005

Mohamed Dhalla, P.Eng.
Director
Section 53, *Ontario Water Resources Act*

KD/
c: District Manager, MOE Ottawa
Jeff Shillington, Novatech Engineering Consultants Ltd.

Date: 12/2/2022 File: D07-12-21-0211
To: Santhosh Kuruvilla
From: Charles Warnock
Project: 415 Legget Drive and 2700 Solandt Road
Subject: Stormwater Review

TECHNICAL MEMO

The following is a summary of the review that was undertaken by GM BluePlan Engineering and Asset Management Service of the Stormwater Management Report for 415 Legget Drive (WSP Canada Inc., dated August 4, 2022).

Comments

It is our recommendation that the following comments be provided to the applicant:

Stormwater Management Report:

1. In the swale calculation sheet, please revise the slope of swale S1 to match the drawings (i.e. 1%) and provide the flow depths.
2. Please discuss how the required enhanced level quality control will be achieved through the enhanced swale. In general, enhanced swales are not intended to provide 80% TSS removal. The response letter indicates that all water quality control is provided by the enhances swales, and not by the pond. Please demonstrate how the 80% TSS control target is being achieved. Please include details in the report, not in the response letter.
3. The design of the swales should be revised such that the swale outlets are above the permanent pond elevation. If the swales are submerged, how will quality control be achieved?
4. Area SU-8 includes SWM wet pond. The surface water area 0.1868 ha should be considered impervious. Please review and revise C value as necessary.
5. Under 3.4 floodplain considerations. What is the 100-year water surface elevation in the receiving stream and how does it affect the outlet structure and outflows from the pond?
6. Please provide tables all the rainfall hyetographs used.
7. Need to provide discussion on the parameters used in the model. It should also include a table listing the parameters for the different drainage areas. Explain how you came up with the width parameter and slope. We note a very high width parameter (27550 m) for one area.
8. Section 1.3 reads as if a SWM pond will be designed when there does not seem to be an changes proposed. Background information should include the MECP ECA issued for 415 Legget Drive.
9. Section 1.4. The allowable release rate from the SWM pond should be based on the current SWM pond design approved by the MECP and issued an Industrial ECA. The design approved for the ECA was based on predevelopment conditions that existed during the original site plan development. The MECP ECA for the existing SWM pond shows a release rate of 310 L/s for the 100-year storm.
10. The quantity criteria are confusing. Is it pre-development flows into the pond that are maintained, or predevelopment flows from the pond? Section 2.3 2nd paragraph

states that primary function is to control flows into the pond to predevelopment conditions. Section 3.2 says to match flows from the site which would be from the pond outlet.

11. Table 6. The permanent pool and active storage volumes listed in the ECA are less than what is stated here.
12. Bottom of page 8 refers to the wet pond storage curve in Appendix C. This curve cannot be found. Please provide the stage discharge curve.

Modeling:

1. Please provide models for all pre-development and post-development scenarios.

Drawings:

1. Please provide additional cross-sections of the SWM pond.
2. Please revise the grading around the building to prevent ponding against the building during the 100-year scenario.

February 28, 2023

Nadia De Santi
WSP Canada Group
Via email: Nadia.de-santi@wsp.com

Subject: Site Plan Control Application – 415 Legget Drive and 2700 Solandt Road – 4th Review Comments

Please find below the consolidated comments from the 4th review of the above noted application.

1. Engineering

- 1.1. Please provide an updated Site Grading Plan Review memo from the retained geotechnical consultant now that lightweight fill is shown on the December 1st, 2022 revision of the grading plan.
- 1.2. Should be noted on the grading plan where insulation for footings is anticipated due to lack of 1.5m cover.
- 1.3. What is reason for proposed 250mm water system? Seems large for the little domestic demand. Was water plant designed as 250mm to meet max day plus fire scenario? What are pressures throughout system if new portion of private plant is proposed as 200mm? Water age could be a concern if water plant is unnecessarily oversized especially if small domestic demand.
- 1.4. Provide roof drain memo as per attached City template signed by structural and mechanical eng. Previous memo submitted was not as per template.

SWM Report Comments:

- 1.5. Initial Comment: In the swale calculation sheet, please revise the slope of swale S1 to match the drawings (i.e. 1%) and provide the flow depths.

Developer Response: The swale calculation sheet has been revised.

Follow-up: No further comment.

- 1.6. Initial Comment: Please discuss how the required enhanced level quality control will be achieved through the enhanced swale. In general, enhanced swales are not intended to provide 80% TSS removal. The response letter indicates that all water quality control is provided by the enhanced swales, and not by the pond. Please demonstrate how the 80% TSS control target is being achieved. Please include details in the report, not in the response letter.

Developer Response: The report has been updated to discuss the water quality impact of the existing pond, including the calculation of water quality volume.

Follow-up: The change to the pond volumes will require an amendment to the existing ECA. No further comment.

- 1.7. Initial Comment: The design of the swales should be revised such that the swale outlets are above the permanent pond elevation. If the swales are submerged, how will quality control be achieved?

Developer Response: Water quality control will be achieved with the existing SWM pond. See response to comment #2.

Follow-up: No further comment.

- 1.8. Initial Comment: Area SU-8 includes SWM wet pond. The surface water area 0.1868 ha should be considered impervious. Please review and revise C value as necessary.

Developer Response: An imperviousness of 100% was used for the pond. Figures have been updated to reflect this.

Follow-up: No further comment.

- 1.9. Initial Comment: Under 3.4 floodplain considerations. What is the 100-year water surface elevation in the receiving stream and how does it affect the outlet structure and outflows from the pond?

Developer Response: A discussion of tailwater conditions has been added.

Follow-up: The new proposal is to lower the bottom of the v-notch weir to equal the elevation of the downstream channel bottom. Flows over a weir usually are free flowing and above the downstream channel bottom. Downstream channel should be included in the model to support this new proposal.

- 1.10. Initial Comment: Please provide tables all the rainfall hyetographs used.

Developer Response: The 3-hour Chicago design storm was used for each return period event. Hyetographs have been added to the report.

Follow-up: No further comment.

- 1.11. Initial Comment: Need to provide discussion on the parameters used in the model. It should also include a table listing the parameters for the different drainage areas. Explain how you came up with the width parameter and slope. We note a very high width parameter (27,550 m) for one area.

Developer Response: Model parameters have been added to the report. The catchment with the high width parameter is the pond to lower the T_c . A methodology section has been added to the report.

Follow-up: No further comment.

- 1.12. Initial Comment: Section 1.3 reads as if a SWM pond will be designed when there does not seem to be any changes proposed. Background information should include the MECP ECA issued for 415 Legget Drive.

Developer Response: The MECP ECA for 415 Legget has been reviewed. Section 1.3 refers to the stormwater management plan, which in this case involves rooftop storage. Wording has been revised for clarity.

Follow-up: No further comment.

- 1.13. Initial Comment: Section 1.4. The allowable release rate from the SWM pond should be based on the current SWM pond design approved by the MECP and issued an Industrial ECA. The design approved for the ECA was based on predevelopment

conditions that existed during the original site plan development. The MECP ECA for the existing SWM pond shows a release rate of 310 L/s for the 100-year storm.

Developer Response: The MECP ECA for 415 Legget has been reviewed, and the report has been updated accordingly. The target release rate is now set at 310 L/s.

Follow-up: No further comment.

- 1.14. Initial Comment: The quantity criteria are confusing. Is it pre-development flows into the pond that are maintained, or predevelopment flows from the pond? Section 2.3 2nd paragraph states that primary function is to control flows into the pond to predevelopment conditions. Section 3.2 says to match flows from the site which would be from the pond outlet.

Developer Response: The report has been updated to reflect that the target release rate from the site is 310 L/s.

Follow-up: No further comment.

- 1.15. Initial Comment: Table 6. The permanent pool and active storage volumes listed in the ECA are less than what is stated here.

Developer Response: The MECP ECA for 415 Legget has been reviewed and the report has been updated.

Follow-up: It still appears that the noted volumes in Section 4.3 are larger than what is described in the ECA. Where is this additional storage volume coming from?

- 1.16. Initial Comment: Bottom of page 8 refers to the wet pond storage curve in Appendix C. This curve cannot be found. Please provide the stage discharge curve.

Developer Response: The storage curves are included in Appendix C. Discharge is modelled as a weir in PCSWMM.

wsp			Project: 415 Legget Dr		No.: 219-00058-04	
			By: KK		Date: 2023-01-20	
			Checked: AJ		Checked: 2023-01-20	
Subject: SWM CALCULATIONS - Storage Curves					Page: 1	
Existing Storage Curve			Proposed Storage Curve			
Elevation (m)	Area (m2)	Volume (m3)	Elevation (m)	Area (m2)	Volume (m3)	
75.1	1383	0	75.1	1383	0	
76.1	1868	1625	76.1	1868	1626	
76.2	1934	1815	76.2	2252	1831	
76.3	2185	2021	76.3	2635	2076	
76.4	2471	2254	76.4	3110	2363	
76.5	2891	2522	76.5	4013	2719	
76.6	3525	2843	76.56	4702	2981	
76.7	5616	3300	76.63	5428	3335	

Follow-up: As requested in the original comment provide the outflows for the different depths in this table. Also if we calculate the active storage in this table, they do not seem to line up with those shown in table 7 of the report. Starting at 76.2 and going to 76.5 the active storages (cu.m) are 76.2 (190), 76.3 (396), 76.4 (629), and 76.5 (890). Table 7 the elevations (volume cu.m.) are 76.33 (534), 76.37 (663), 76.41 (761), 76.44 (893), 76.47 (993), 76.5 (1100). Example,

table 7 shows 663 cu. m. at 76.37 which is greater than 629 shown above at 76.4.

It would be helpful if table 7 also included the outflows. Please provide information on how the proposed v notch weir set at the channel bottom is modeled in PCSWMM. The invert of the weir is set at the channel bottom, and this will not be free flowing. With this new proposal to lower the outlet please provide information on the downstream channel and its possible effect on the outflow from the pond. There should be a channel segment added downstream of the pond outlet structure.

The change in the outlet will be include in the amendment to the ECA.

The new proposed small V-notch weir at channel bottom should have some sort of protection from debris. One small stick will block the weir.

Modelling Comments:

- 1.17. Initial Comment: Please provide models for all pre-development and post-development scenarios.

Developer Response: Models have been provided with the submission package.

Follow-up: Please provide an individual model file for pre- and post-development for each storm (i.e. all 2-yr, 5-yr, 10-yr, 25-yr, 50-yr, 100-yr, 100-yr+20%, 100yr+fixed tailwater, 25mm for the 3-hr and 6-hr Chicago storms). This is necessary to ensure consistent results between the design process and review process, as we review the specific models and associated results in PCSWMM. The drawings show stress test results however the tables in the report do not. Please include the stress test results in the report.

Drawing Comments:

- 1.18. Initial Comment: Please provide additional cross-sections of the SWM pond.

Developer Response: Cross sections E-E has been added, however below the permanent pool elevation the pond is assumed to be 1m deep with 3:1 side slope.

Follow-up: Section D-D appears to be taken through the outlet weir and downstream channel however the cross-section information does not portray this.

- 1.19. Initial Comment: Please revise the grading around the building to prevent ponding against the building during the 100-year scenario.

Developer Response: Grading has been revised, and the 100 yr. and 100 yr. + 20% ponding limits have been changed. There is no ponding against the building.

Follow-up: No further comment.

Other Comments:

- 1.20. With the new proposal to dredge the pond and alter the outlet the sediment and erosion control needs to discuss how downstream water way will be protected when the dredging takes place. How will the stream be protected with the construction of the new outlet weir? How will the pond function during the construction of the new weir? What will be done with the sediments removed in the dredging?



If you have further questions, please contact Justin Armstrong, Infrastructure Project Manager (justin.armstrong@ottawa.ca).

2. Conservation Authority

Comments:

- 2.1. No further comments.

3. Environmental Planning and Forestry

Comments:

- 3.1. The City still hasn't heard back from MECP, a special condition in the site plan approval will be included.
- 3.2. A preclearing site inspection may be required prior to tree removal.
- 3.3. Trees 85 and 166-169 are right on the edge of impacts, but not listed in the legend. Having them shown as retained on the list would assist with clarity.
- 3.4. The List of Data in the EIS/TCR is still showing the previous list of removals. If the date table is updated to reflect what is shown in legend of Figure 5, this will finalize the TCR.
- 3.5. Please consider relocating/exchanging the proposed Black Walnuts and Sugar maples adjacent to parking lots to alternative planting locations. Black walnut produces fruit which can adversely impact parked cars, and sugar maples are not salt tolerant species and are likely to struggle in those areas. These are great species otherwise and should still be included. The locations east of building A, and south/east of building B are great locations for the walnuts and sugar maples.
- 3.6. Please consider including Bur oak into the plant list. They are more hardy and salt tolerant than the red oaks and would do better in the parking areas.
- 3.7. Please confirm the island planting strips for trees is at least 3.0m in width. Allowing a 1.5m setback from either side.
- 3.8. It is crucial for long term growth and development that these island plantings are also provided with quality topsoil, typically 300mm in depth. In many cases these islands are filled with mostly aggregates and the trees are unable to survive. Which may have been the case for many of the existing island plantings on site to fail.
- 3.9. 5 Serviceberry trees are shown on the plan, yet 6 are identified in the list. Where is the last tree? The three located off the west edge of building 2 are appropriate, but please replace the 2 AC's off the SW corner of the building with larger species.
- 3.10. Please consider balancing out some of the proposed Brandon elms and lindens into the oaks, walnuts and hickories for better diversity.
- 3.11. Is there any opportunity for additional trees off the east side of building B, and the SE corner of building A around what appears to be a garbage area. There are open grass sections in both areas that would benefit from canopy cover given the extensive tree removal required to facilitate development. There is also an open grass area west of the 5 proposed white pines where additional trees could be included.

4. Planning

Comments:

- 4.1. Please adjust the zoning information on the site plan for Building A minimum rear yard setback, currently says 8.96m but 7.50m is identified on the plan (stats table).
- 4.2. Please adjust the zoning information for Building B minimum interior side yard setback to read 11.50m (stats table).
- 4.3. Please clarify on the Landscape Plan why several Keynotes #2 are identified throughout parking areas with the same tree symbol as 'proposed' or 'retained' (?) trees. If these trees are to be removed, identify that on the legend. The TCR and LP need to be coordinated, specifically identifying on the LP the trees to be retained (including groupings labeled as retained) and trees to be removed. Please include tree symbols with **X** to indicate removals, a lighter lineweight or hatch is not sufficient.
- 4.4. There are several tree symbols that are not included in the legend, please clarify if these are proposed/existing to remain/to be removed. Such as the symbol below.



- 4.5. The landscape plan must be stamped by a landscape architect.
- 4.6. The landscape plan needs to include information in the title block consistent with the City's [Guide to preparing studies and plans | City of Ottawa](#) for site plan approval.

The development review team will be happy to meet you to discuss comments and resolve issues.

Should there be any other questions, please do not hesitate to contact me.

Yours Truly,
Molly Smith

APPENDIX

B EXHIBITS





CLIENT
ACCESS PROPERTY DEVELOPMENT

PROJECT
415 LEGGET DRIVE

TITLE
**EXHIBIT 1
EXISTING CONDITIONS
DRAINAGE MOSAIC**

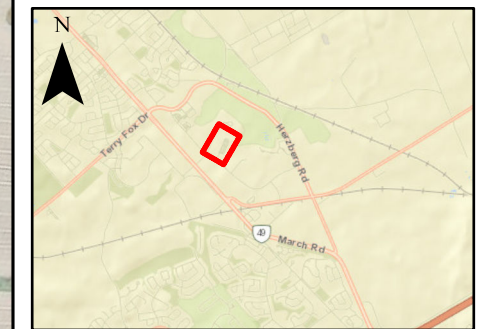

LEGEND

- Existing Ditches
- Existing Wet Pond
- Existing Drainage Areas
- S-BEX
- S-EXT1
- S-U1
- S-U2

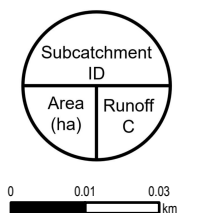

DRAWN BY
MO

March 2022

NAD 1983 MTM 9

1:1,275

CHECKED BY
AJ



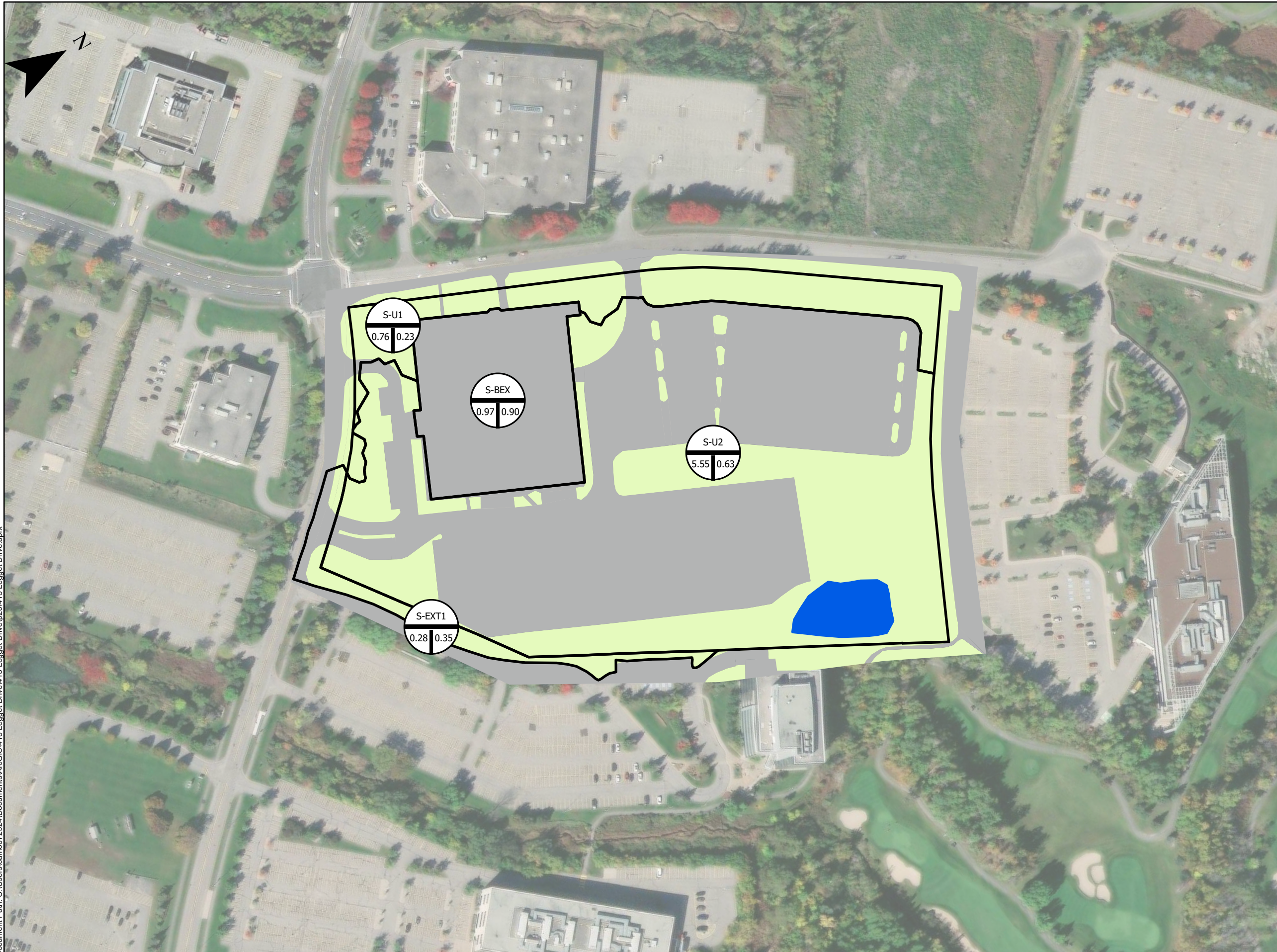

Document Path: C:\Users\cam072924\Documents\ArcGIS\415 Legget Drive\201415 Legget Drive.aprx

CLIENT
ACCESS PROPERTY DEVELOPMENT

PROJECT
415 LEGGET DRIVE

TITLE
**EXHIBIT 2
EXISTING CONDITIONS
LAND USE**

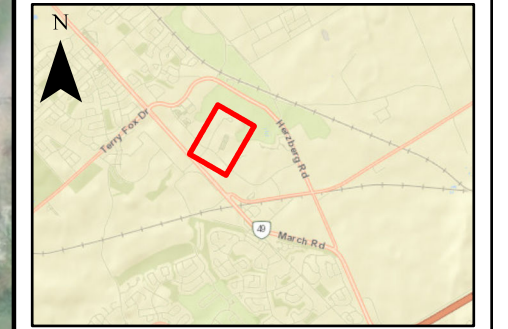

- LEGEND**
- Existing Drainage Areas
 - Existing Wet Pond
 - Land Use
 - Impervious
 - Pervious

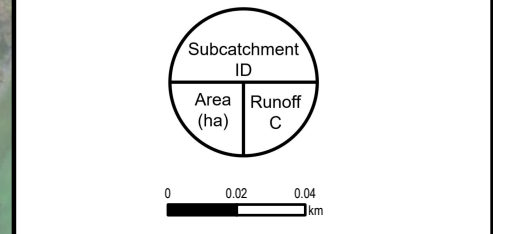

DRAWN BY	MO	CHECKED BY	AJ
	March 2022		
	NAD 1983 MTM 9		
	1:2,204		

Document Path: C:\Users\CAK\72000\Documents\ArcGIS\15 Packages\415 Legget 2022-03 08360p20\415 Legget Drive.aprx



CLIENT
ACCESS PROPERTY DEVELOPMENT

PROJECT
415 LEGGET DRIVE

TITLE
**EXHIBIT 3
PROPOSED CONDITIONS
DRAINAGE MOSAIC**

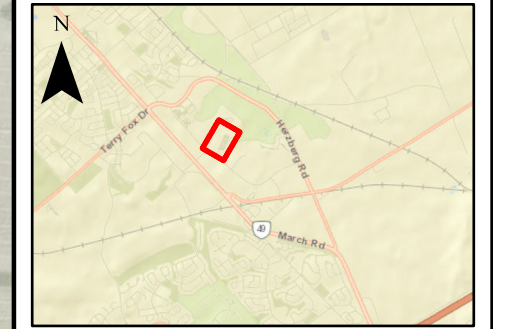

LEGEND

- - - Proposed Swales
- Existing Wet Pond
- External Drainage Area

Proposed Drainage Areas

	S-BA
	S-BB
	S-BEX
	S-U1
	S-U2
	S-U3
	S-U4
	S-U5
	S-U6
	S-U7
	S-U8
	Pond

Subcatchment
ID
Area
(ha) | Runoff
C

0 0.01 0.03
km

DRAWN BY KK	CHECKED BY AJ
December 2022	
NAD 1983 MTM 9	
1:1,275	

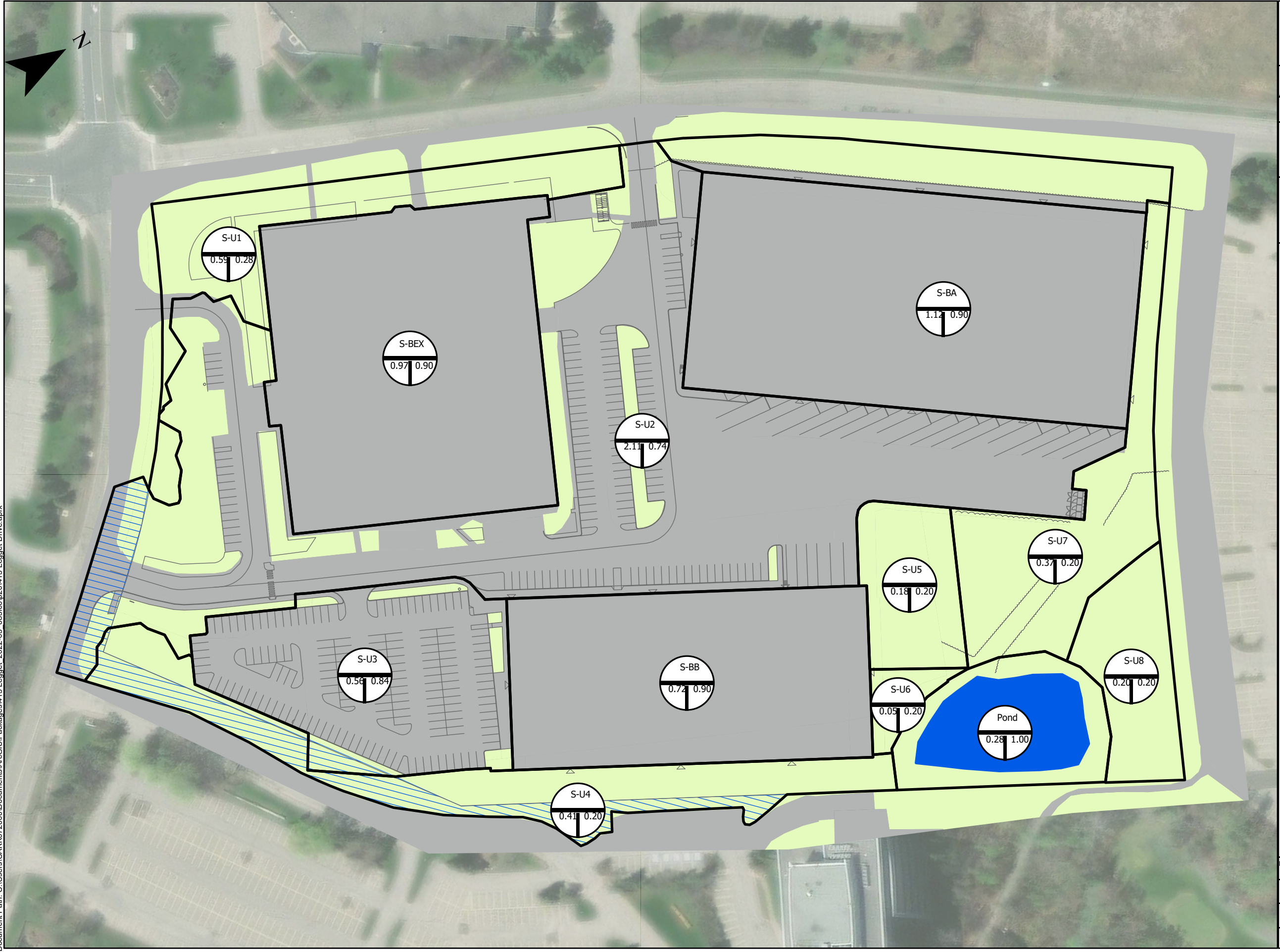

CLIENT
ACCESS PROPERTY DEVELOPMENT

PROJECT
415 LEGGET DRIVE

TITLE
**EXHIBIT 4
PROPOSED CONDITIONS
LAND USE**

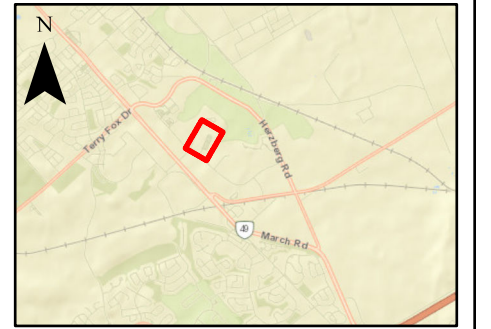

- LEGEND**
- External Drainage Area
 - Existing Wet Pond
 - Land Use
 - Impervious
 - Pervious

Subcatchment ID	
Area (ha)	Runoff C
S-U1	0.59 0.28
S-BEX	0.97 0.90
S-U2	2.11 0.74
S-BA	1.12 0.90
S-U3	0.56 0.84
S-BB	0.72 0.90
S-U4	0.41 0.20
S-U5	0.18 0.20
S-U6	0.05 0.20
S-U7	0.37 0.20
Pond	0.28 1.00
S-U8	0.20 0.20

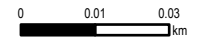

DRAWN BY KK	CHECKED BY AJ
December 2022	
NAD 1983 MTM 9	
1:1,275	

Document Path: C:\Users\CAK\72000\Documents\ArcGIS\ISIPackages\415 Legget 2022-03 083fc0\p20\415 Legget Drive.aprx

APPENDIX

C CALCULATIONS & PCSWMM OUTPUT





SWALE CALCULATION SHEET

415 Legget - 25 mm, 4 hour storm

Check for satisfaction of criteria for enhanced grass swales (TRCA, 2010)

Designed by: Kathryn Kerker Date: 2022-12-13
 Checked by: Ayham Jadallah Date: 2022-12-13
 Approved by: Ayham Jadallah Date: 2022-12-13
 Drawing Ref:

Standard Design Calculation Sheet (Rational Method)

Location			Drainage Areas			Rational Method Runoff					Swale Data					Comment		
Street Name or Description	From	To	Runoff Coefficients			Individual AC	Accum. AC	Runoff Coefficient C	Rainfall Intensity i mm/h	Q L/s	Side Slope x:1	Bottom Width m	Depth m	Slope %	Length m	Q L/s	Vel. m/s	
			0.20 ha	0.70 ha	0.90 ha													
S1	LCB01	Pond	0.37		1.12	1.08	1.08	0.73	37.1	112	3	0.75	0.15	1.00	174	112	0.6	
S2	LCB02	Pond	0.73		1.68	1.66	1.66	0.69	35.5	164	3	0.75	0.20	0.60	64	164	0.6	
S3	LCB03	Pond	0.48		1.08	1.07	1.07	0.68	35.3	104	3	0.75	0.16	0.60	153	104	0.5	

Notes:

- The slope of open channels will depend on various factors including roadway longitudinal grade and natural topography;
- The minimum allowable ditch/swale slope is 0.5% (1% is desirable);
- For Runoff Coefficient (C), grassed area = 0.2, ballast = 0.7, paved area = 0.9
- Also for C, add 10% for 25-year storm event, 20% for 50-year storm event and 25% for 100-year storm event (update this in appropriate drainage cell)
- A minimum time of concentration of 10min shall be used
- Rainfall intensity determined by MOE Stormwater Management Planning and Design Manual (2003) $i = 43C + 5.9$
- Maximum velocity = 0.5m/s, Flow depth below 0.1m preferred
- Channel protection in the form of sodding, gabion, armour stone, riprap, asphalt, and concrete lining may be required depending on design flow and velocities; and
- Roughness Coefficient (n) = 0.04
- Permissible velocities for channels lined with grass are included in Appendix 6-C of the Ottawa Sewer Design Guidelines.
- Depths will be greater where checkdams are used



Project:	415 Legget Dr	No.:	219-00058-04	
By:	KK	Date:	2023-03-14	Page:
Checked:	AJ	Checked:	2023-03-14	1

Subject: **SWM CALCULATIONS - Storage Curves**

Existing Storage Curve

Elevation (m)	Area (m2)	Volume (m3)
75.1	1383	0
76.1	1868	1625
76.2	1934	1815
76.3	2185	2021
76.4	2471	2254
76.5	2891	2522
76.6	3525	2843
76.7	5616	3300

Proposed Storage Curve

Elevation (m)	Area (m2)	Volume (m3)	Active Storage (m3)	Outflow (m3/s)
75.1	1383	0	0	0.000
76.1	1868	1626	0	0.000
76.2	2252	1831	206	0.003
76.3	2635	2076	450	0.052
76.4	3110	2363	738	0.167
76.5	4013	2719	1094	0.310
76.56	4702	2981	1355	
76.63	5428	3335	1710	

PRE-DEVELOPMENT CONDITIONS



WET POND - EXISTING CONDITIONS

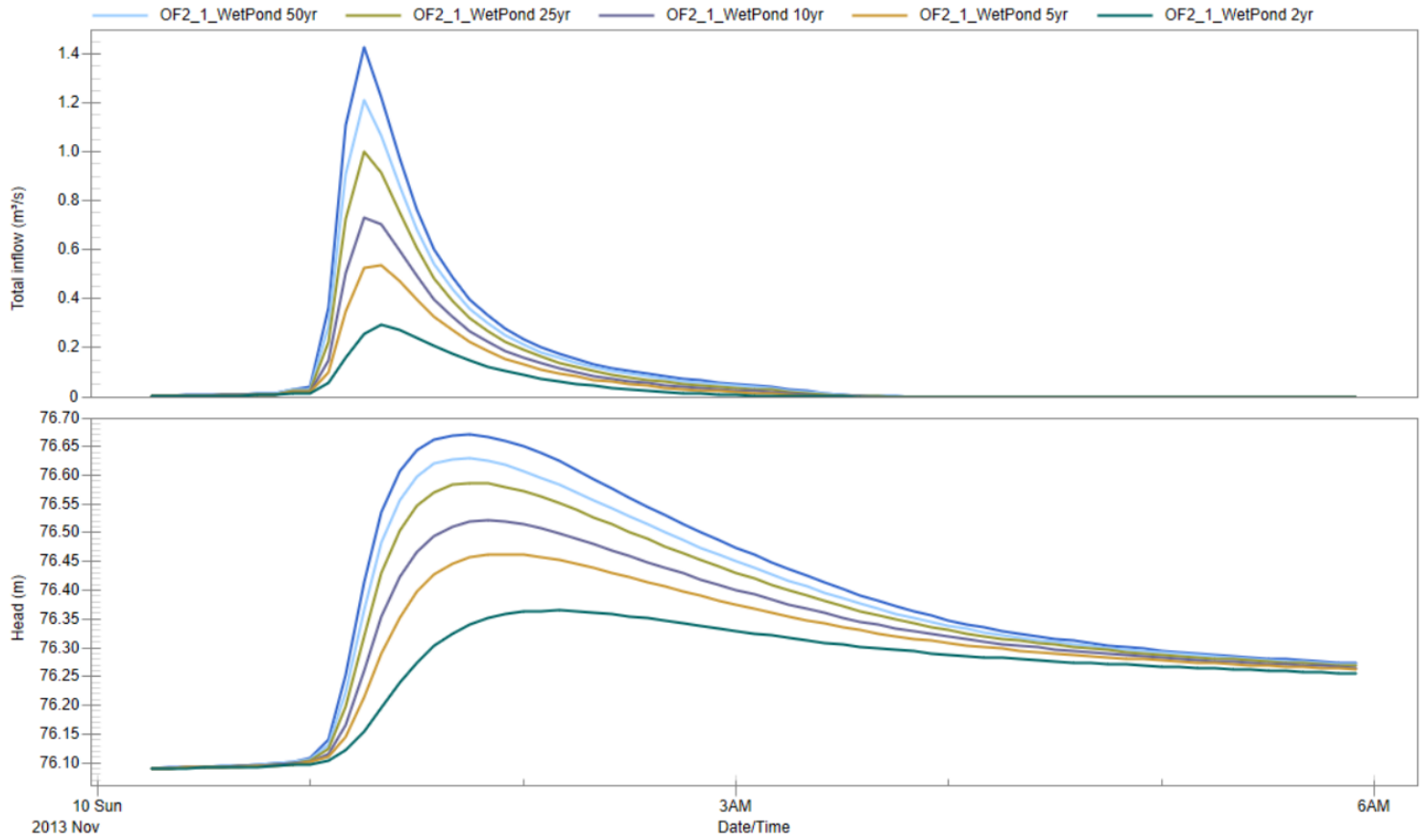

2-year Pre Development

EPA STORM WATER MANAGEMENT MODEL - VERSION 5.1 (Build 5.1.013)

 Element Count

 Number of rain gages 16
 Number of subcatchments ... 5
 Number of nodes 4
 Number of links 3
 Number of pollutants 0
 Number of land uses 0

 Raingage Summary

Name	Data Source	Data Type	Recording Interval
100yr_3hr_Chicago	100yr_3hr_Chicago	INTENSITY	10 min.
100yr_3hr_Chicago_Climate_Change	100yr_3hr_Chicago_Increase_20percent	INTENSITY	10 min.
100yr_6hr_Chicago	100yr_6hr_Chicago	INTENSITY	10 min.
100yr_6hr_Chicago_Climate_Change	100yr_6hr_Chicago_Increase_20percent	INTENSITY	10 min.
10yr_3hr_Chicago	10yr_3hr_Chicago	INTENSITY	10 min.
10yr_6hr_Chicago	10yr_6hr_Chicago	INTENSITY	10 min.
25mm_3hr_Chicago	25mm_3hr_Chicago	INTENSITY	10 min.
25mm_4hr_Chicago	25mm_4hr_Chicago	INTENSITY	10 min.
25yr_3hr_Chicago	25yr_3hr_Chicago	INTENSITY	10 min.
25yr_6hr_Chicago	25yr_6hr_Chicago	INTENSITY	10 min.
2yr_3hr_Chicago	2yr_3hr_Chicago	INTENSITY	10 min.
2yr_6hr_Chicago	2yr_6hr_Chicago	INTENSITY	10 min.
50yr_3hr_Chicago	50yr_3hr_Chicago	INTENSITY	10 min.
50yr_6hr_Chicago	50yr_6hr_Chicago	INTENSITY	10 min.
5yr_3hr_Chicago	5yr_3hr_Chicago	INTENSITY	10 min.
5yr_6hr_Chicago	5yr_6hr_Chicago	INTENSITY	10 min.

 Subcatchment Summary

Name	Area	Width	%Imperv	%Slope	Rain Gage	Outlet
Pond	0.28	27550.00	100.00	3.3690	2yr_3hr_Chicago	OF2_1_WetPond
S-BEX	0.97	167.35	99.91	2.0000	2yr_3hr_Chicago	OF1
S-EXT1	0.28	7.91	24.119	7.3320	2yr_3hr_Chicago	OF2_1_WetPond
S-U1	0.76	162.55	8.85	4.9330	2yr_3hr_Chicago	OF1
S-U2	5.27	198.99	66.00	3.4650	2yr_3hr_Chicago	OF2_1_WetPond

 Node Summary

Name	Type	Invert Elev.	Max. Depth	Ponded Area	External Inflow
OF2_2_KizellDrain	JUNCTION	76.09	1.91	0.0	
OF1	OUTFALL	77.70	0.00	0.0	
OF2	OUTFALL	75.90	1.49	0.0	
OF2_1_WetPond	STORAGE	75.10	3.00	0.0	

 Link Summary

Name	From Node	To Node	Type	Length	%Slope	Roughness
C1	OF2_2_KizellDrain	OF2	CONDUIT	11.1	1.7054	0.0350
W1	OF2_1_WetPond	OF2_2_KizellDrain	WEIR			
W2	OF2_1_WetPond	OF2_2_KizellDrain	WEIR			

 Cross Section Summary

Conduit	Shape	Full Depth	Full Area	Hyd. Rad.	Max. Width	No. of Barrels	Full Flow
C1	Transect1	1.49	10.54	0.51	22.03	1	25.26

 Transect Summary

Transect	Area:	0.0004	0.0016	0.0037	0.0066	0.0103
		0.0148	0.0201	0.0261	0.0326	0.0398
		0.0475	0.0558	0.0646	0.0741	0.0841
		0.0947	0.1059	0.1177	0.1302	0.1434
		0.1572	0.1717	0.1868	0.2026	0.2189
		0.2359	0.2535	0.2716	0.2904	0.3099
		0.3302	0.3512	0.3730	0.3957	0.4193
		0.4438	0.4693	0.4958	0.5235	0.5525
		0.5838	0.6182	0.6557	0.6960	0.7395
		0.7867	0.8369	0.8897	0.9440	1.0000
Hrad:		0.0283	0.0566	0.0849	0.1132	0.1415

	0.1698	0.2008	0.2341	0.2683	0.3015
	0.3339	0.3656	0.3968	0.4277	0.4581
	0.4872	0.5142	0.5413	0.5682	0.5951
	0.6221	0.6493	0.6764	0.7057	0.7351
	0.7644	0.7936	0.8227	0.8487	0.8719
	0.8954	0.9185	0.9383	0.9587	0.9797
	0.9957	1.0114	1.0281	1.0389	1.0427
	1.0049	0.9690	0.9539	0.9451	0.9240
Width:	0.9138	0.9228	0.9436	0.9738	1.0000
	0.0131	0.0263	0.0394	0.0525	0.0657
	0.0788	0.0905	0.1006	0.1098	0.1189
	0.1281	0.1372	0.1463	0.1555	0.1646
	0.1742	0.1846	0.1949	0.2054	0.2159
	0.2264	0.2369	0.2475	0.2571	0.2667
	0.2763	0.2859	0.2955	0.3063	0.3183
	0.3302	0.3425	0.3563	0.3701	0.3840
	0.4001	0.4168	0.4335	0.4533	0.4772
	0.5243	0.5769	0.6225	0.6678	0.7269
	0.7828	0.8252	0.8580	0.8811	1.0000

 NOTE: The summary statistics displayed in this report are based on results found at every computational time step, not just on results from each reporting time step.

 Analysis Options

Flow Units CMS
 Process Models:
 Rainfall/Runoff YES
 RDII NO
 Snowmelt NO
 Groundwater NO
 Flow Routing YES
 Ponding Allowed YES
 Water Quality NO
 Infiltration Method HORTON
 Flow Routing Method DYNNAVE
 Surcharge Method EXTRAN
 Starting Date 11/10/2013 00:00:00
 Ending Date 11/10/2013 06:00:00
 Antecedent Dry Days 0.0
 Report Time Step 00:05:00
 Wet Time Step 00:05:00
 Dry Time Step 00:05:00
 Routing Time Step 1.00 sec
 Variable Time Step YES
 Maximum Trials 20
 Number of Threads 1
 Head Tolerance 0.001500 m

	Volume	Depth
Runoff Quantity Continuity	hectare-m	mm
Total Precipitation	0.241	31.860
Evaporation Loss	0.000	0.000
Infiltration Loss	0.126	16.677
Surface Runoff	0.109	14.434
Final Storage	0.007	0.982
Continuity Error (%)	-0.730	

	Volume	Volume
Flow Routing Continuity	hectare-m	10 ⁶ ltr
Dry Weather Inflow	0.000	0.000
Wet Weather Inflow	0.109	1.092
Groundwater Inflow	0.000	0.000
RDII Inflow	0.000	0.000
External Inflow	0.000	0.000
External Outflow	0.077	0.774
Flooding Loss	0.000	0.000
Evaporation Loss	0.000	0.000
Exfiltration Loss	0.000	0.000
Initial Stored Volume	0.161	1.607
Final Stored Volume	0.192	1.924
Continuity Error (%)	0.000	

 Time-Step Critical Elements

None

 Highest Flow Instability Indexes

 All links are stable.

 Routing Time Step Summary

Minimum Time Step	: 0.50 sec
Average Time Step	: 1.00 sec
Maximum Time Step	: 1.00 sec
Percent in Steady State	: 0.00
Average Iterations per Step	: 2.00
Percent Not Converging	: 0.00

 Subcatchment Runoff Summary

Subcatchment	Total Precip mm	Total Runon mm	Total Evap mm	Total Infil mm	Imperv Runoff mm	Perv Runoff mm	Total Runoff mm	Total Runoff 10 ⁶ ltr	Peak Runoff CMS	Runoff Coeff
Pond	31.86	0.00	0.00	0.00	31.86	0.00	31.86	0.09	0.06	1.000
S-BX	31.86	0.00	0.00	0.03	30.53	0.00	30.53	0.30	0.21	0.958
S-EXT1	31.86	0.00	0.00	30.67	7.39	0.89	0.89	0.00	0.00	0.028
S-U1	31.86	0.00	0.00	29.02	2.69	0.04	2.73	0.02	0.02	0.086
S-U2	31.86	0.00	0.00	18.10	20.13	12.96	12.96	0.68	0.27	0.407

 Node Depth Summary

Node	Type	Average Depth Meters	Maximum Depth Meters	Maximum HGL Meters	Time of Max Occurrence days hr:min	Reported Max Depth Meters
OF2_2_KizellDrain	JUNCTION	0.08	0.15	76.24	0 02:08	0.15
OF1	OUTFALL	0.00	0.00	77.70	0 00:00	0.00
OF2	OUTFALL	0.07	0.13	76.03	0 02:08	0.13
OF2_1_WetPond	STORAGE	1.16	1.26	76.36	0 02:08	1.26

 Node Inflow Summary

Node	Type	Maximum Lateral Inflow CMS	Maximum Total Inflow CMS	Time of Max Occurrence days hr:min	Lateral Inflow 10 ⁶ ltr	Total Inflow 10 ⁶ ltr	Flow Balance Error Percent
OF2_2_KizellDrain	JUNCTION	0.000	0.067	0 02:08	0	0.456	0.028
OF1	OUTFALL	0.221	0.221	0 01:10	0.318	0.318	0.000
OF2	OUTFALL	0.000	0.067	0 02:08	0	0.456	0.000
OF2_1_WetPond	STORAGE	0.292	0.292	0 01:20	0.774	2.38	0.001

 Node Surge Summary

No nodes were surcharged.

 Node Flooding Summary

No nodes were flooded.

 Storage Volume Summary

Storage Unit	Average Volume 1000 m3	Avg Full	Evap Loss	Exfil Loss	Maximum Volume 1000 m3	Max Full	Time of Max Occurrence days hr:min	Maximum Outflow CMS
OF2_1_WetPond	1.937	5	0	0	2.169	5	0 02:08	0.067

 Outfall Loading Summary

Outfall Node	Flow Freq Pcnt	Avg Flow CMS	Max Flow CMS	Total Volume 10 ⁶ ltr
OF1	86.65	0.017	0.221	0.318
OF2	82.56	0.026	0.067	0.456
System	84.61	0.043	0.067	0.774

 Link Flow Summary

Link	Type	Maximum Flow CMS	Time of Max Occurrence days hr:min	Maximum Veloc m/sec	Max/ Full Flow	Max/ Full Depth
C1	CHANNEL	0.067	0 02:08	0.70	0.00	0.09
W1	WEIR	0.009	0 02:07			1.00
W2	WEIR	0.057	0 02:08			0.30

Flow Classification Summary

Conduit	Adjusted /Actual Length	Up Dry	Down Dry	Up Sub Dry	Down Sub Dry	Sup Crit	Up Crit	Down Crit	Norm Crit	Inlet Ltd	Inlet Ctrl
C1	1.00	0.04	0.00	0.00	0.00	0.89	0.07	0.00	0.00	0.00	0.00

 Conduit Surge Summary

No conduits were surcharged.

Analysis begun on: Wed Aug 3 10:35:47 2022
 Analysis ended on: Wed Aug 3 10:35:47 2022
 Total elapsed time: < 1 sec

EPA STORM WATER MANAGEMENT MODEL - VERSION 5.1 (Build 5.1.013)

 Element Count

 Number of rain gages 16
 Number of subcatchments 5
 Number of nodes 4
 Number of links 3
 Number of pollutants 0
 Number of land uses 0

 Rainage Summary

Name	Data Source	Data Type	Recording Interval
100yr_3hr_Chicago	100yr_3hr_Chicago	INTENSITY	10 min.
100yr_3hr_Chicago_Climate_Change	100yr_3hr_Chicago_Increase_20percent	INTENSITY	10 min.
100yr_6hr_Chicago	100yr_6hr_Chicago	INTENSITY	10 min.
100yr_6hr_Chicago_Climate_Change	100yr_6hr_Chicago_Increase_20percent	INTENSITY	10 min.
10yr_3hr_Chicago	10yr_3hr_Chicago	INTENSITY	10 min.
10yr_6hr_Chicago	10yr_6hr_Chicago	INTENSITY	10 min.
25mm_3hr_Chicago	25mm_3hr_Chicago	INTENSITY	10 min.
25mm_4hr_Chicago	25mm_4hr_Chicago	INTENSITY	10 min.
25yr_3hr_Chicago	25yr_3hr_Chicago	INTENSITY	10 min.
25yr_6hr_Chicago	25yr_6hr_Chicago	INTENSITY	10 min.
2yr_3hr_Chicago	2yr_3hr_Chicago	INTENSITY	10 min.
2yr_6hr_Chicago	2yr_6hr_Chicago	INTENSITY	10 min.
50yr_3hr_Chicago	50yr_3hr_Chicago	INTENSITY	10 min.
50yr_6hr_Chicago	50yr_6hr_Chicago	INTENSITY	10 min.
5yr_3hr_Chicago	5yr_3hr_Chicago	INTENSITY	10 min.
5yr_6hr_Chicago	5yr_6hr_Chicago	INTENSITY	10 min.

 Subcatchment Summary

Name	Area	Width	%Imperv	%Slope	Rain Gage	Outlet
Pond	0.28	27550.00	100.00	3.3690	100yr_3hr_Chicago	OF2_1_WetPond
S-BXK	0.97	167.35	99.91	2.0000	100yr_3hr_Chicago	CF1
S-EXT1	0.28	7.91	24.19	7.3320	100yr_3hr_Chicago	OF2_1_WetPond
S-U1	0.76	162.55	8.85	4.9330	100yr_3hr_Chicago	CF1
S-U2	5.27	198.99	66.00	3.4650	100yr_3hr_Chicago	OF2_1_WetPond

 Node Summary

Name	Type	Invert Elev.	Max. Depth	Ponded Area	External Inflow
OF2_2_KizellDrain	JUNCTION	76.09	1.91	0.0	
OF1	OUTFALL	77.70	0.00	0.0	
OF2	OUTFALL	75.90	1.49	0.0	
OF2_1_WetPond	STORAGE	75.10	3.00	0.0	

 Link Summary

Name	From Node	To Node	Type	Length	%Slope	Roughness
C1	OF2_2_KizellDrain	OF2	CONDUIT	11.1	1.7054	0.0350
W1	OF2_1_WetPond	OF2_2_KizellDrain	WEIR			
W2	OF2_1_WetPond	OF2_2_KizellDrain	WEIR			

 Cross Section Summary

Conduit	Shape	Depth	Full Area	Hyd. Rad.	Max. Width	No. of Barrels	Full Flow
C1	Transect1	1.49	10.54	0.51	22.03	1	25.26

 Transect Summary

Transect	Area:	0.0004	0.0016	0.0037	0.0066	0.0103	0.0148	0.0201	0.0261	0.0326	0.0398	0.0475	0.0558	0.0646	0.0741	0.0841	0.0947	0.1059	0.1177	0.1302	0.1434	0.1572	0.1717	0.1868	0.2026	0.2189	0.2359	0.2535	0.2716	0.2904	0.3099	0.3302	0.3512	0.3730	0.3957	0.4193	0.4438	0.4693	0.4958	0.5235	0.5525	0.5838	0.6182	0.6557	0.6960	0.7395	0.7867	0.8369	0.8897	0.9440	1.0000
----------	-------	--------	--------	--------	--------	--------	--------	--------	--------	--------	--------	--------	--------	--------	--------	--------	--------	--------	--------	--------	--------	--------	--------	--------	--------	--------	--------	--------	--------	--------	--------	--------	--------	--------	--------	--------	--------	--------	--------	--------	--------	--------	--------	--------	--------	--------	--------	--------	--------	--------	--------

Hrad:

0.0283	0.0566	0.0849	0.1132	0.1415
0.1698	0.2008	0.2341	0.2683	0.3015
0.3339	0.3656	0.3968	0.4277	0.4581
0.4872	0.5142	0.5413	0.5682	0.5951
0.6221	0.6493	0.6764	0.7057	0.7351
0.7644	0.7936	0.8227	0.8487	0.8719
0.8954	0.9185	0.9383	0.9587	0.9797
0.9957	1.0114	1.0281	1.0389	1.0427
1.0049	0.9690	0.9539	0.9451	0.9240
0.9138	0.9228	0.9435	0.9738	1.0000

Width:

0.0131	0.0263	0.0394	0.0525	0.0657
0.0798	0.0905	0.1006	0.1098	0.1199
0.1281	0.1372	0.1463	0.1555	0.1646
0.1742	0.1846	0.1949	0.2054	0.2159
0.2264	0.2369	0.2475	0.2571	0.2667
0.2763	0.2859	0.2955	0.3063	0.3183
0.3302	0.3425	0.3563	0.3701	0.3840
0.4001	0.4168	0.4335	0.4533	0.4772
0.5243	0.5769	0.6225	0.6678	0.7269
0.7828	0.8252	0.8580	0.8811	1.0000

NOTE: The summary statistics displayed in this report are based on results found at every computational time step, not just on results from each reporting time step.

 Analysis Options

Flow Units CMS
 Process Models:
 Rainfall/Runoff YES
 RDII NO
 Snowmelt NO
 Groundwater NO
 Flow Routing YES
 Ponding Allowed YES
 Water Quality NO
 Infiltration Method HORTON
 Flow Routing Method DYNWAVE
 Surcharge Method EXTRAN
 Starting Date 11/10/2013 00:00:00
 Ending Date 11/10/2013 06:00:00
 Antecedent Dry Days 0
 Report Time Step 00:05:00
 Wet Time Step 00:05:00
 Dry Time Step 00:05:00
 Routing Time Step 1.00 sec
 Variable Time Step YES
 Maximum Trials 20
 Number of Threads 1
 Head Tolerance 0.001500 m

Runoff Quantity	Continuity	Volume	Depth
		hectare-m	mm
Total Precipitation	0.542	71.677
Evaporation Loss	0.000	0.000
Infiltration Loss	0.154	20.371
Surface Runoff	0.386	51.038
Final Storage	0.007	0.983
Continuity Error (%)	-0.998	

Flow Routing	Continuity	Volume	Volume
		hectare-m	10 ⁶ ltr
Dry Weather Inflow	0.000	0.000
Wet Weather Inflow	0.386	3.860
Groundwater Inflow	0.000	0.000
RDII Inflow	0.000	0.000
External Inflow	0.000	0.000
External Outflow	0.351	3.507
Flooding Loss	0.000	0.000
Evaporation Loss	0.000	0.000
Exfiltration Loss	0.000	0.000
Initial Stored Volume	0.161	1.607
Final Stored Volume	0.196	1.960
Continuity Error (%)	-0.001	

 Time-Step Critical Elements

None

 Highest Flow Instability Indexes

All links are stable.

 Routing Time Step Summary

Minimum Time Step : 0.50 sec
 Average Time Step : 1.00 sec
 Maximum Time Step : 1.00 sec
 Percent in Steady State : 0.00
 Average Iterations per Step : 2.00

Percent Not Converging : 0.00

Subcatchment Runoff Summary

Subcatchment	Precip mm	Runon mm	Evap mm	Infil mm	Runoff mm	Runoff mm	Runoff mm	Runoff mm	Runoff mm	Runoff mm	Runoff mm	Coeff
Fond	71.68	0.00	0.00	0.00	71.67	0.00	71.67	0.20	0.14	1.000		
S-BX	71.68	0.00	0.00	0.04	70.56	0.03	70.59	0.69	0.48	0.985		
S-EXT1	71.68	0.00	0.00	42.78	17.06	28.83	28.83	0.08	0.03	0.402		
S-U1	71.68	0.00	0.00	42.11	6.21	23.89	30.10	0.23	0.18	0.420		
S-U2	71.68	0.00	0.00	20.86	46.65	50.55	50.55	2.67	1.36	0.705		

Node Depth Summary

Node	Type	Average Depth Meters	Maximum Depth Meters	Maximum HGL Meters	Time of Max Occurrence days hr:min	Reported Max Depth Meters
OF2_2_KisellDrain	JUNCTION	0.14	0.29	76.38	0 01:43	0.29
OF1	OUTFALL	0.00	0.00	77.70	0 00:00	0.00
OF2	OUTFALL	0.13	0.27	76.17	0 01:43	0.27
OF2_1_WetPond	STORAGE	1.26	1.57	76.67	0 01:43	1.57

Node Inflow Summary

Node	Type	Maximum Lateral Inflow CMS	Maximum Total Inflow CMS	Time of Max Occurrence days hr:min	Lateral Inflow Volume 10^6 ltr	Total Inflow Volume 10^6 ltr	Flow Balance Error Percent
OF2_2_KisellDrain	JUNCTION	0.000	0.421	0 01:43	0	2.59	0.006
OF1	OUTFALL	0.662	0.662	0 01:10	0.918	0.918	0.000
OF2	OUTFALL	0.000	0.421	0 01:43	0	2.59	0.000
OF2_1_WetPond	STORAGE	1.429	1.429	0 01:15	2.94	4.55	0.001

Node Surcharge Summary

No nodes were surcharged.

Node Flooding Summary

No nodes were flooded.

Storage Volume Summary

Storage Unit	Average Volume 1000 m3	Avg Pcnt	Evap Pcnt	Exfil Pcnt	Maximum Volume 1000 m3	Max Full	Time of Max Occurrence days hr:min	Maximum Outflow CMS
OF2_1_WetPond	2.225	6	0	0	3.146	8	0 01:43	0.421

Outfall Loading Summary

Outfall Node	Flow Freq Pcnt	Avg Flow CMS	Max Flow CMS	Total Volume 10^6 ltr
OF1	92.20	0.046	0.662	0.918
OF2	85.54	0.140	0.421	2.590
System	88.87	0.186	0.421	3.507

Link Flow Summary

Link	Type	Maximum Flow CMS	Time of Max Occurrence days hr:min	Maximum Veloce m/sec	Max/ Full Flow	Max/ Full Depth
C1	CHANNEL	0.421	0 01:43	1.12	0.02	0.19
W1	WEIR	0.014	0 01:43			1.00
W2	WEIR	0.407	0 01:43			1.00

Flow Classification Summary

Conduit	Adjusted /Actual Length	Fraction of Time in Flow Class									
		Dry Dry	Up Dry	Down Dry	Sub Crit	Sup Crit	Up Crit	Down Crit	Norm Crit	Inlet Ltd	Ctrl
C1	1.00	0.04	0.00	0.00	0.88	0.08	0.00	0.00	0.00	0.00	0.00

Conduit Surcharge Summary

No conduits were surcharged.

Analysis begun on: Tue Aug 2 16:11:37 2022
Analysis ended on: Tue Aug 2 16:11:37 2022
Total elapsed time: < 1 sec

POST DEVELOPMENT CONDITIONS

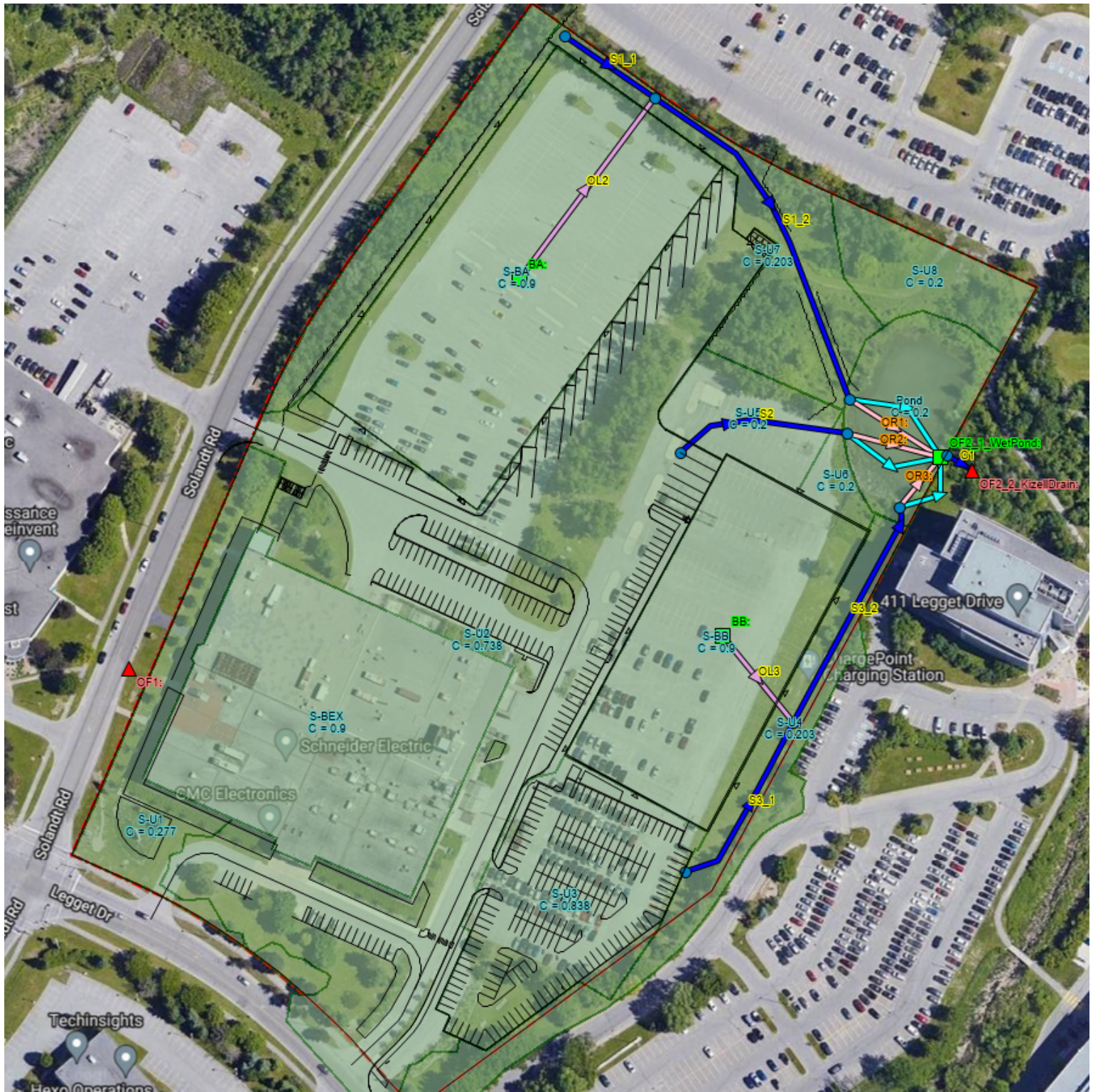

WET POND - PROPOSED CONDITIONS

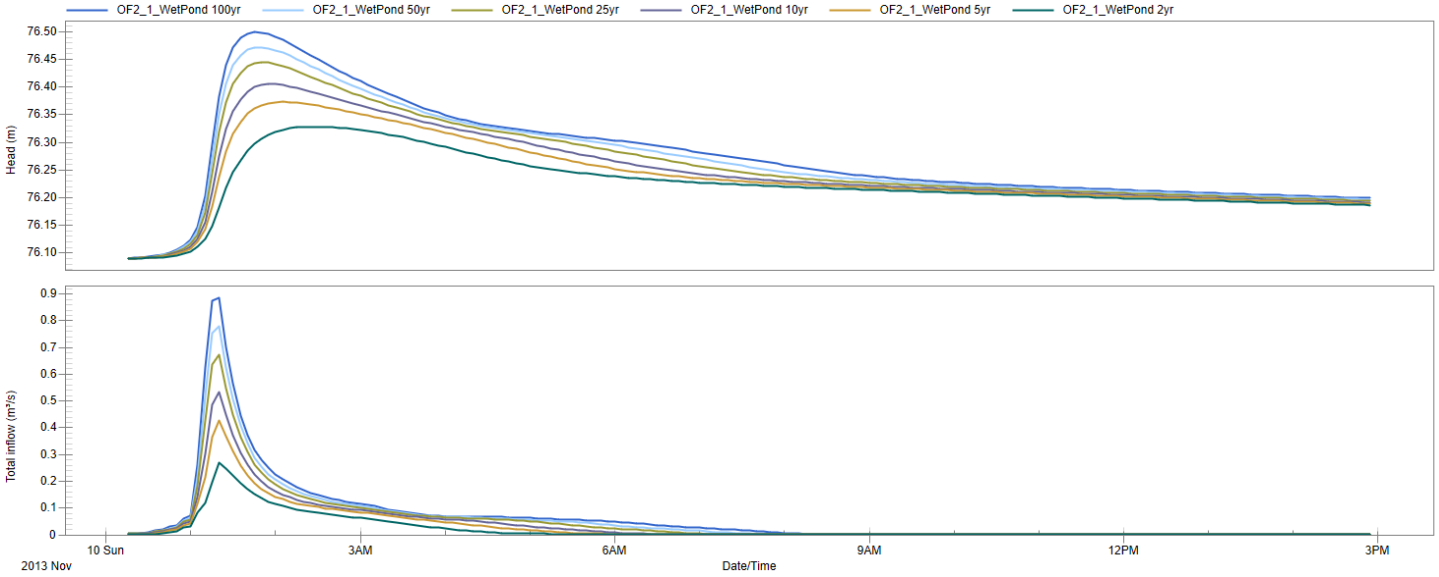

BUILDING A

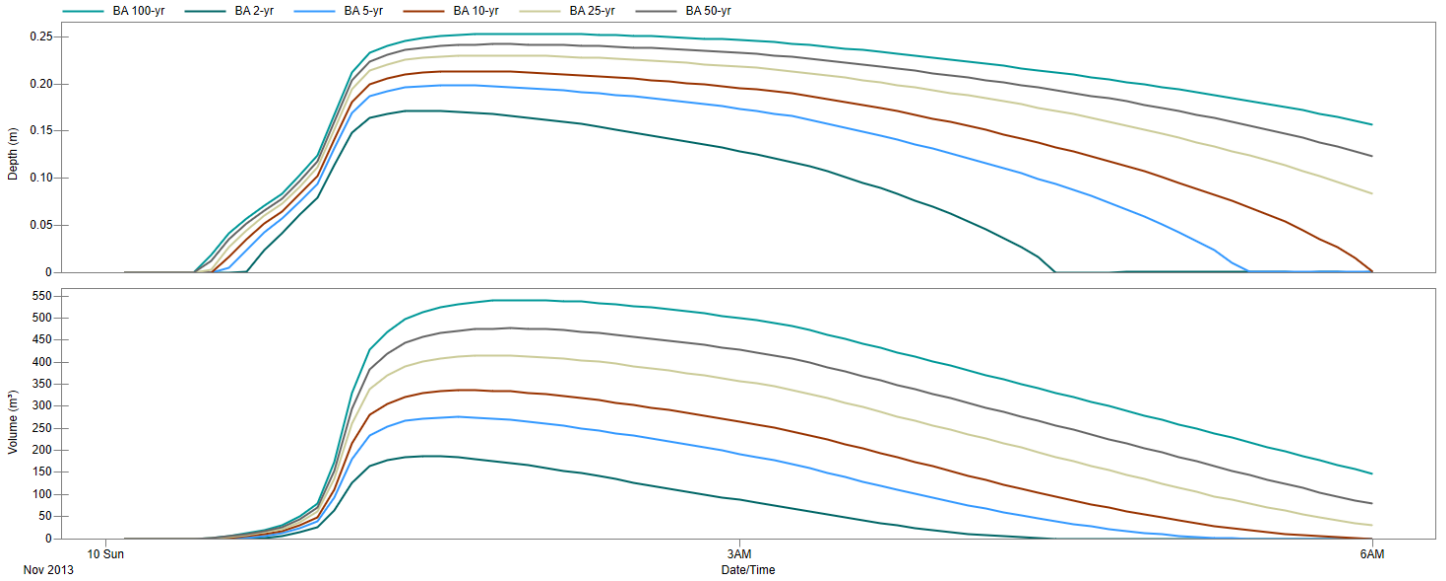

BUILDING B

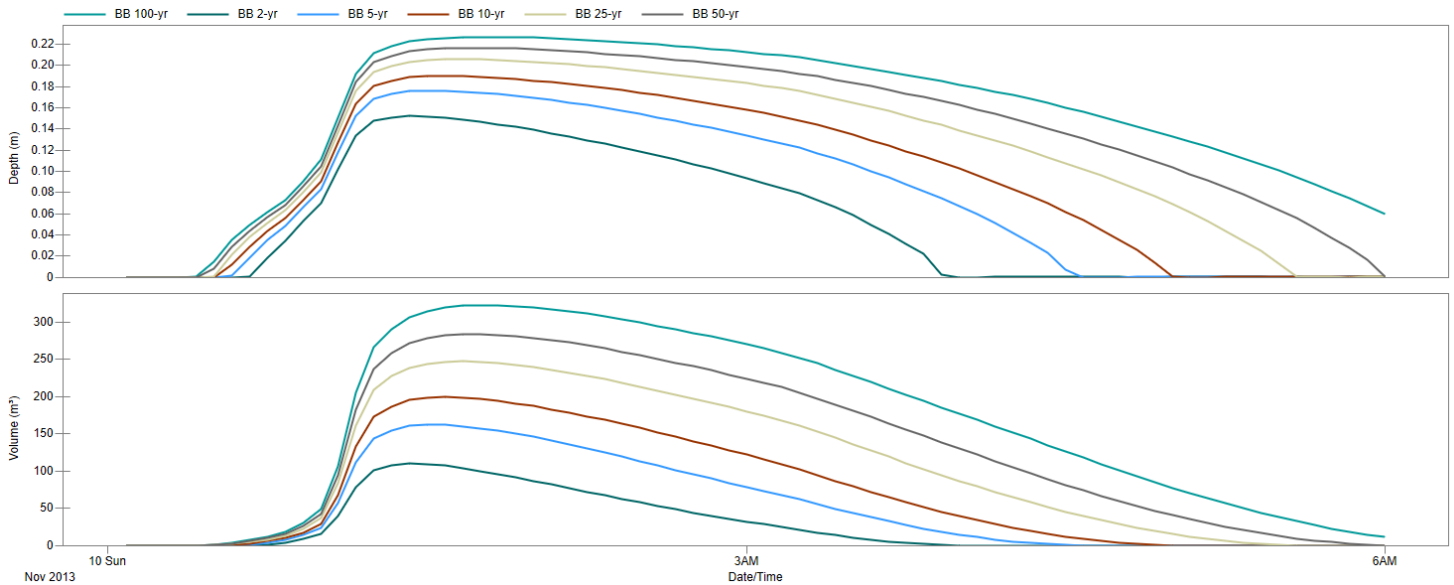

2-year Post Development

EPA STORM WATER MANAGEMENT MODEL - VERSION 5.1 (Build 5.1.015)

WARNING 02: maximum depth increased for Node J1
 WARNING 02: maximum depth increased for Node J3
 WARNING 02: maximum depth increased for Node J4
 WARNING 02: maximum depth increased for Node J5
 WARNING 02: maximum depth increased for Node J8

 Element Count

 Number of rain gages 16
 Number of subcatchments ... 12
 Number of nodes 15
 Number of links 16
 Number of pollutants 0
 Number of land uses 0

Raingage Summary

Name	Data Source	Data Type	Recording Interval
100yr_3hr_Chicago	100yr_3hr_Chicago	INTENSITY	10 min.
100yr_3hr_Chicago_Climate_Change	100yr_3hr_Chicago_Increase_20percent	INTENSITY	10 min.
100yr_6hr_Chicago	100yr_6hr_Chicago	INTENSITY	10 min.
100yr_6hr_Chicago_Climate_Change	100yr_6hr_Chicago_Increase_20percent	INTENSITY	10 min.
10yr_3hr_Chicago	10yr_3hr_Chicago	INTENSITY	10 min.
10yr_6hr_Chicago	10yr_6hr_Chicago	INTENSITY	10 min.
25mm_3hr_Chicago	25mm_3hr_Chicago	INTENSITY	10 min.
25mm_4hr_Chicago	25mm_4hr_Chicago	INTENSITY	10 min.
25yr_3hr_Chicago	25yr_3hr_Chicago	INTENSITY	10 min.
25yr_6hr_Chicago	25yr_6hr_Chicago	INTENSITY	10 min.
2yr_3hr_Chicago	2yr_3hr_Chicago	INTENSITY	10 min.
2yr_6hr_Chicago	2yr_6hr_Chicago	INTENSITY	10 min.
50yr_3hr_Chicago	50yr_3hr_Chicago	INTENSITY	10 min.
50yr_6hr_Chicago	50yr_6hr_Chicago	INTENSITY	10 min.
5yr_3hr_Chicago	5yr_3hr_Chicago	INTENSITY	10 min.
5yr_6hr_Chicago	5yr_6hr_Chicago	INTENSITY	10 min.

Subcatchment Summary

Name	Area	Width	%Imperv	%Slope	Rain Gage	Outlet
Pond	0.28	27550.00	100.00	3.3690	2yr_3hr_Chicago	OF2_1_WetPond
S-BA	1.12	660.53	100.00	2.0000	2yr_3hr_Chicago	BA
S-BB	0.72	422.71	99.98	2.0000	2yr_3hr_Chicago	BB
S-BBX	0.97	221.34	99.97	2.0000	2yr_3hr_Chicago	CF1
S-U1	0.59	125.57	15.46	4.9330	2yr_3hr_Chicago	OF1
S-U2	2.11	70.80	77.97	2.0000	2yr_3hr_Chicago	J2
S-U3	0.56	54.08	91.54	0.6000	2yr_3hr_Chicago	J6
S-U4	0.41	31.45	5.39	0.6000	2yr_3hr_Chicago	J6
S-U5	0.18	73.32	5.00	2.0000	2yr_3hr_Chicago	J2
S-U6	0.05	19.04	5.00	2.0000	2yr_3hr_Chicago	OF2_1_WetPond
S-U7	0.37	98.63	5.36	2.0000	2yr_3hr_Chicago	J1
S-U8	0.20	41.38	5.00	2.0000	2yr_3hr_Chicago	OF2_1_WetPond

Node Summary

Name	Type	Invert Elev.	Max. Depth	Ponded Area	External Inflow
J1	JUNCTION	77.50	1.00	0.0	
J10	JUNCTION	0.00	0.00	0.0	
J2	JUNCTION	76.20	1.00	0.0	
J3	JUNCTION	75.85	1.31	0.0	
J4	JUNCTION	75.85	1.31	0.0	
J5	JUNCTION	75.85	1.31	0.0	
J6	JUNCTION	76.72	1.00	0.0	
J7	JUNCTION	76.33	1.00	0.0	
J8	JUNCTION	77.13	1.00	0.0	
J9	JUNCTION	76.09	1.91	0.0	
OF1	OUTFALL	77.70	0.00	0.0	
OF2_2_KizellDrain	OUTFALL	75.90	1.49	0.0	
BA	STORAGE	95.50	2.00	0.0	
BB	STORAGE	95.50	2.00	0.0	
OF2_1_WetPond	STORAGE	75.10	3.00	0.0	

Link Summary

Name	From Node	To Node	Type	Length	%Slope	Roughness
C1	J9	OF2_2_KizellDrain	CONDUIT	11.1	1.7054	0.0350
S1_1	J1	J8	CONDUIT	39.1	0.9572	0.0350
S1_2	J8	J3	CONDUIT	133.4	0.3566	0.0350
S2	J2	J4	CONDUIT	64.2	0.5453	0.0350
S3_1	J6	J7	CONDUIT	69.7	0.5555	0.0350
S3_2	J7	J5	CONDUIT	86.9	0.5561	0.0350
OR1	J3	OF2_1_WetPond	ORIFICE			
OR2	J4	OF2_1_WetPond	ORIFICE			
OR3	J5	OF2_1_WetPond	ORIFICE			
CI_1	OF2_1_WetPond	J9	WEIR			
W1	J3	OF2_1_WetPond	WEIR			
W2	J4	OF2_1_WetPond	WEIR			

W3	J5	OF2_1_WetPond	WEIR
W4	J9	OF2_1_WetPond <td>WEIR</td>	WEIR
OL2	BA	J8	OUTLET
OL3	BB	J7	OUTLET

Cross Section Summary

Conduit	Shape	Full Depth	Full Area	Hyd. Rad.	Max. Width	No. of Barrels	Full Flow
C1	Transect1	1.40	10.54	0.51	22.03	1	25.26
S1_1	TRAPEZOIDAL	1.00	3.75	0.53	6.75	1	6.87
S1_2	TRAPEZOIDAL	1.00	3.75	0.53	6.75	1	6.86
S2	TRAPEZOIDAL	1.00	3.75	0.53	6.75	1	5.18
S3_1	TRAPEZOIDAL	1.00	3.75	0.53	6.75	1	5.23
S3_2	TRAPEZOIDAL	1.00	3.75	0.53	6.75	1	5.23

Transect Summary

Transect	Area:	0.0004	0.0016	0.0037	0.0066	0.0103
Transect1	Area:	0.0148	0.0201	0.0261	0.0326	0.0398
		0.0475	0.0558	0.0646	0.0741	0.0841
		0.0947	0.1059	0.1177	0.1302	0.1434
		0.1572	0.1717	0.1868	0.2026	0.2189
		0.2359	0.2535	0.2716	0.2904	0.3099
		0.3302	0.3512	0.3730	0.3957	0.4193
		0.4438	0.4693	0.4958	0.5235	0.5525
		0.5838	0.6182	0.6557	0.6960	0.7395
		0.7867	0.8369	0.8897	0.9440	1.0000
		0.0283	0.0566	0.0849	0.1132	0.1415
Hrad:		0.1698	0.2008	0.2341	0.2683	0.3015
		0.3339	0.3656	0.3968	0.4277	0.4581
		0.4872	0.5142	0.5413	0.5682	0.5951
		0.6231	0.6493	0.6764	0.7057	0.7351
		0.7644	0.7936	0.8227	0.8487	0.8719
		0.8954	0.9185	0.9383	0.9587	0.9797
		0.9957	1.0114	1.0281	1.0389	1.0427
		1.0049	0.9690	0.9539	0.9451	0.9240
		0.9138	0.9228	0.9436	0.9738	1.0000
		0.0131	0.0263	0.0394	0.0525	0.0657
Width:		0.0788	0.0905	0.1006	0.1098	0.1189
		0.1281	0.1372	0.1463	0.1555	0.1646
		0.1742	0.1846	0.1949	0.2054	0.2159
		0.2264	0.2369	0.2475	0.2571	0.2667
		0.2763	0.2859	0.2955	0.3063	0.3183
		0.3302	0.3425	0.3563	0.3701	0.3840
		0.4001	0.4168	0.4335	0.4533	0.4772
		0.5243	0.5769	0.6225	0.6678	0.7269
		0.7828	0.8252	0.8580	0.8811	1.0000
		0.0311	0.0622	0.0933	0.1244	0.1555
Hrad:		0.1867	0.2208	0.2574	0.2950	0.3315
		0.3671	0.4020	0.4363	0.4702	0.5037
		0.5357	0.5653	0.5951	0.6247	0.6543
		0.6840	0.7138	0.7437	0.7759	0.8082
		0.8404	0.8725	0.9045	0.9331	0.9586
		0.9845	1.0099	1.0316	1.0540	1.0771
		1.0948	1.1120	1.1304	1.1422	1.1464
		1.1049	1.0653	1.0488	1.0391	1.0159
		1.0047	1.0146	1.0374	1.0706	1.0000
		0.0131	0.0263	0.0394	0.0525	0.0657
Width:		0.0788	0.0905	0.1006	0.1098	0.1189
		0.1281	0.1372	0.1463	0.1555	0.1646
		0.1742	0.1846	0.1949	0.2054	0.2159
		0.2264	0.2369	0.2475	0.2571	0.2667
		0.2763	0.2859	0.2955	0.3063	0.3183
		0.3302	0.3425	0.3563	0.3701	0.3840
		0.4001	0.4168	0.4335	0.4533	0.4772
		0.5243	0.5769	0.6225	0.6678	0.7269
		0.7828	0.8252	0.8580	0.8811	1.0000

NOTE: The summary statistics displayed in this report are based on results found at every computational time step, not just on results from each reporting time step.

Analysis Options

Flow Units CMS
 Process Model:
 Rainfall/Runoff YES
 RDII NO
 Snowmelt NO
 Groundwater NO
 Flow Routing YES
 Ponding Allowed YES
 Water Quality NO
 Infiltration Method HORTON
 Flow Routing Method DYNNAVE
 Surchage Method EXTRAN
 Starting Date 11/10/2013 00:00:00
 Ending Date 11/13/2013 00:00:00
 Antecedent Dry Days 0.0
 Report Time Step 00:05:00
 Wet Time Step 00:05:00
 Dry Time Step 00:05:00
 Routing Time Step 1.00 sec
 Variable Time Step YES
 Maximum Trials 20
 Number of Threads 2
 Head Tolerance 0.001500 m

	Volume hectare-m	Depth mm
Runoff Quantity Continuity	-----	-----
Total Precipitation	0.241	31.860
Evaporation Loss	0.000	0.000
Infiltration Loss	0.085	11.243
Surface Runoff	0.149	19.752
Final Storage	0.008	1.065
Continuity Error (%)	-0.626	

	Volume hectare-m	Volume 10 ⁶ ltr
Flow Routing Continuity	-----	-----
Dry Weather Inflow	0.000	0.000
Wet Weather Inflow	0.149	1.494
Groundwater Inflow	0.000	0.000
RDII Inflow	0.000	0.000
External Inflow	0.000	0.000
External Outflow	0.146	1.455
Flooding Loss	0.000	0.000
Evaporation Loss	0.000	0.000
Exfiltration Loss	0.000	0.000
Initial Stored Volume	0.164	1.645
Final Stored Volume	0.171	1.706
Continuity Error (%)	-0.704	

Time-Step Critical Elements
 None

Highest Flow Instability Indexes
 Link OR1 (15)
 Link W2 (14)
 Link W3 (13)
 Link OR3 (10)
 Link OR2 (7)

Routing Time Step Summary
 Minimum Time Step : 0.50 sec
 Average Time Step : 1.00 sec
 Maximum Time Step : 1.00 sec
 Percent in Steady State : 0.00
 Average Iterations per Step : 2.00
 Percent Not Converging : 0.00
 Time Step Frequencies :
 1.000 - 0.871 sec : 100.00 %
 0.871 - 0.758 sec : 0.00 %
 0.758 - 0.660 sec : 0.00 %
 0.660 - 0.574 sec : 0.00 %
 0.574 - 0.500 sec : 0.00 %

Subcatchment Runoff Summary

Subcatchment	Total Precip mm	Total Runon mm	Total Evap mm	Total Infil mm	Imperv mm	Perv Runoff mm	Total Runoff mm	Total Runoff 10 ⁶ ltr	Peak Runoff CMS	Runoff Coeff
Pond	31.86	0.00	0.00	0.00	31.86	0.00	31.86	0.09	0.06	1.000
S-BA	31.86	0.00	0.00	0.00	30.46	0.00	30.46	0.34	0.24	0.956
S-BB	31.86	0.00	0.00	0.01	30.46	0.00	30.46	0.22	0.15	0.956
S-BBX	31.86	0.00	0.00	0.01	30.55	0.00	30.55	0.30	0.21	0.959
S-U1	31.86	0.00	0.00	26.92	4.70	0.04	4.74	0.03	0.02	0.149
S-U2	31.86	0.00	0.00	13.10	23.79	17.82	17.82	0.38	0.14	0.559
S-U3	31.86	0.00	0.00	5.44	27.95	25.45	25.45	0.14	0.09	0.799
S-U4	31.86	0.00	0.00	31.76	1.64	0.03	0.03	0.00	0.00	0.001
S-U5	31.86	0.00	0.00	31.63	1.52	0.20	0.20	0.00	0.00	0.006
S-U6	31.86	0.00	0.00	31.63	1.52	0.20	0.20	0.00	0.00	0.006

S-U7	31.86	0.00	0.00	31.66	1.63	0.15	0.15	0.00	0.00	0.005
S-U8	31.86	0.00	0.00	31.70	1.52	0.11	0.11	0.00	0.00	0.004

Node Depth Summary

Node	Type	Average Depth Meters	Maximum Depth Meters	Maximum HGL Meters	Time of Max Occurrence days hr:min	Reported Max Depth Meters
J1	JUNCTION	0.00	0.01	77.51	0 01:13	0.01
J10	JUNCTION	0.00	0.00	0.00	0 00:00	0.00
J2	JUNCTION	0.01	0.20	76.40	0 01:21	0.19
J3	JUNCTION	0.30	0.48	76.33	0 02:27	0.48
J4	JUNCTION	0.30	0.48	76.33	0 02:25	0.48
J5	JUNCTION	0.30	0.48	76.33	0 02:26	0.48
J6	JUNCTION	0.00	0.15	76.87	0 01:15	0.15
J7	JUNCTION	0.00	0.17	76.50	0 01:17	0.17
J8	JUNCTION	0.00	0.08	77.21	0 01:21	0.08
J9	JUNCTION	0.04	0.16	76.25	0 02:27	0.16
OF1	OUTFALL	0.00	0.00	77.70	0 00:00	0.00
OF2_2_KizellDrain	OUTFALL	0.03	0.14	76.04	0 02:27	0.14
BA	STORAGE	0.01	0.17	95.67	0 01:32	0.17
BB	STORAGE	0.00	0.15	95.65	0 01:24	0.15
OF2_1_WetPond	STORAGE	1.05	1.23	76.33	0 02:27	1.23

Node Inflow Summary

Node	Type	Maximum Lateral Inflow CMS	Maximum Total Inflow CMS	Time of Max Occurrence days hr:min	Lateral Inflow Volume 10 ⁶ ltr	Total Inflow Volume 10 ⁶ ltr	Flow Balance Error Percent
J1	JUNCTION	0.001	0.001	0 01:10	0.000568	0.000568	-0.298
J10	JUNCTION	0.000	0.000	0 00:00	0	0	0.000 ltr
J2	JUNCTION	0.144	0.144	0 01:20	0.376	0.376	-0.289
J3	JUNCTION	0.000	0.035	0 01:21	0	0.349	0.528
J4	JUNCTION	0.000	0.143	0 01:21	0	0.379	0.493
J5	JUNCTION	0.000	0.111	0 01:17	0	0.368	0.690
J6	JUNCTION	0.095	0.095	0 01:15	0.143	0.143	-0.159
J7	JUNCTION	0.000	0.119	0 01:15	0	0.368	-0.013
J8	JUNCTION	0.000	0.035	0 01:13	0	0.349	0.042
J9	JUNCTION	0.000	0.085	0 02:27	0	1.13	0.002
OF1	OUTFALL	0.227	0.227	0 01:10	0.325	0.325	0.000
OF2_2_KizellDrain	OUTFALL	0.000	0.085	0 02:27	0	1.13	0.000
BA	STORAGE	0.240	0.240	0 01:10	0.342	0.342	-1.760
BB	STORAGE	0.153	0.153	0 01:10	0.219	0.219	-2.432
OF2_1_WetPond	STORAGE	0.059	0.270	0 01:20	0.0881	2.78	0.141

Node Surchage Summary

Surcharging occurs when water rises above the top of the highest conduit.

Node	Type	Hours Surcharged	Max. Height Above Crown Meters	Min. Depth Below Rim Meters
J10	JUNCTION	72.00	0.000	0.000

Node Flooding Summary

No nodes were flooded.

Storage Volume Summary

Storage Unit	Average Volume 1000 m3	Avg Full	Evap Loss	Exfil Loss	Maximum Volume 1000 m3	Max Full	Time of Max Occurrence days hr:min	Maximum Outflow CMS
BA	0.005	0	0	0	0.186	0	0 01:32	0.034
BB	0.002	0	0	0	0.110	0	0 01:24	0.028
OF2_1_WetPond	1.735	8	0	0	2.153	10	0 02:27	0.085

Outfall Loading Summary

Outfall Node	Flow Freq CMS	Avg Flow CMS	Max Flow CMS	Total Volume 10 ⁶ ltr
OF1	6.66	0.019	0.227	0.325
OF2_2_KizellDrain	98.68	0.004	0.085	1.130
System	52.67	0.023	0.227	1.455

Link Flow Summary

Link	Type	Maximum Flow CMS	Time of Max Occurrence days hr:min	Maximum Veloc m/sec	Max/ Full Flow	Max/ Full Depth
C1	CHANNEL	0.085	0 02:27	0.74	0.00	0.10
S1_1	CONDUIT	0.001	0 01:13	0.02	0.00	0.04
S1_2	CONDUIT	0.035	0 01:21	0.13	0.01	0.28
S2	CONDUIT	0.143	0 01:21	0.26	0.03	0.33
S3_1	CONDUIT	0.091	0 01:15	0.46	0.02	0.16
S3_2	CONDUIT	0.111	0 01:17	0.24	0.02	0.29
OR1	ORIFICE	0.019	0 01:14			1.00
OR2	ORIFICE	0.046	0 01:19			1.00
OR3	ORIFICE	0.043	0 01:17			1.00
CI_1	WEIR	0.006	0 02:27			1.00
W1	WEIR	0.027	0 02:26			0.17
W2	WEIR	0.094	0 01:25			0.17
W3	WEIR	0.061	0 01:20			0.17
W4	WEIR	0.079	0 02:27			0.16
OL2	DUMMY	0.034	0 01:10			
OL3	DUMMY	0.028	0 01:24			

Flow Classification Summary

Conduit	Adjusted /Actual Length	Fraction of Time in Flow Class								
		Up Dry	Down Dry	Sub Crit	Sup Crit	Up Crit	Down Crit	Norm Inlet	Inlet Ctrl	
C1	1.00	0.00	0.00	0.00	0.99	0.00	0.00	0.00	0.00	0.00
S1_1	1.00	0.01	0.94	0.00	0.05	0.00	0.00	0.00	0.98	0.00
S1_2	1.00	0.00	0.01	0.00	0.99	0.00	0.00	0.00	0.99	0.00
S2	1.00	0.00	0.71	0.00	0.29	0.00	0.00	0.00	0.85	0.00
S3_1	1.00	0.01	0.86	0.00	0.13	0.00	0.00	0.00	0.99	0.00
S3_2	1.00	0.00	0.01	0.00	0.99	0.00	0.00	0.00	0.99	0.00

Conduit Surchage Summary

No conduits were surcharged.

Analysis begun on: Fri Jan 20 11:02:01 2023
Analysis ended on: Fri Jan 20 11:02:05 2023
Total elapsed time: 00:00:04

100-year Post Development

EPA STORM WATER MANAGEMENT MODEL - VERSION 5.1 (Build 5.1.015)

WARNING 02: maximum depth increased for Node J1
WARNING 02: maximum depth increased for Node J3
WARNING 02: maximum depth increased for Node J4
WARNING 02: maximum depth increased for Node J5
WARNING 02: maximum depth increased for Node J8

Element Count

Number of rain gages 16
Number of subcatchments ... 12
Number of nodes 15
Number of links 16
Number of pollutants 0
Number of land uses 0

Rainage Summary

Name	Data Source	Data Type	Recording Interval
100yr_3hr_Chicago	100yr_3hr_Chicago	INTENSITY	10 min.
100yr_3hr_Chicago_Climate_Change	100yr_3hr_Chicago_Increase_20percent	INTENSITY	10 min.
100yr_6hr_Chicago	100yr_6hr_Chicago	INTENSITY	10 min.
100yr_6hr_Chicago_Climate_Change	100yr_6hr_Chicago_Increase_20percent	INTENSITY	10 min.
10yr_3hr_Chicago	10yr_3hr_Chicago	INTENSITY	10 min.
10yr_6hr_Chicago	10yr_6hr_Chicago	INTENSITY	10 min.
25mm_3hr_Chicago	25mm_3hr_Chicago	INTENSITY	10 min.
25mm_6hr_Chicago	25mm_6hr_Chicago	INTENSITY	10 min.
25yr_3hr_Chicago	25yr_3hr_Chicago	INTENSITY	10 min.
25yr_6hr_Chicago	25yr_6hr_Chicago	INTENSITY	10 min.
2yr_3hr_Chicago	2yr_3hr_Chicago	INTENSITY	10 min.
2yr_6hr_Chicago	2yr_6hr_Chicago	INTENSITY	10 min.
50yr_3hr_Chicago	50yr_3hr_Chicago	INTENSITY	10 min.
50yr_6hr_Chicago	50yr_6hr_Chicago	INTENSITY	10 min.
5yr_3hr_Chicago	5yr_3hr_Chicago	INTENSITY	10 min.
5yr_6hr_Chicago	5yr_6hr_Chicago	INTENSITY	10 min.

Subcatchment Summary

Name	Area	Width	%Imperv	%Slope	Rain Gage	Outlet
Pond	0.28	27550.00	100.00	3.3690	100yr_3hr_Chicago	OF2_1_WetPond
S-BA	1.12	660.53	100.00	2.0000	100yr_3hr_Chicago	BA
S-BB	0.72	422.71	99.98	2.0000	100yr_3hr_Chicago	BB
S-BEX	0.97	221.34	99.97	2.0000	100yr_3hr_Chicago	OF1
S-U1	0.59	125.57	15.46	4.9330	100yr_3hr_Chicago	OF1
S-U2	2.11	70.80	77.97	2.0000	100yr_3hr_Chicago	J2
S-U3	0.56	54.08	91.54	0.6000	100yr_3hr_Chicago	J6
S-U4	0.41	31.45	5.39	0.6000	100yr_3hr_Chicago	J6
S-U5	0.18	73.32	5.00	2.0000	100yr_3hr_Chicago	J2
S-U6	0.05	19.04	5.00	2.0000	100yr_3hr_Chicago	OF2_1_WetPond
S-U7	0.37	98.63	5.36	2.0000	100yr_3hr_Chicago	J1
S-U8	0.20	41.38	5.00	2.0000	100yr_3hr_Chicago	OF2_1_WetPond

Node Summary

Name	Type	Invert Elev.	Max. Depth	Ponded Area	External Inflow
J1	JUNCTION	77.50	1.00	0.0	
J10	JUNCTION	0.00	0.00	0.0	
J2	JUNCTION	76.20	1.00	0.0	
J3	JUNCTION	75.85	1.31	0.0	
J4	JUNCTION	75.85	1.31	0.0	
J5	JUNCTION	75.85	1.31	0.0	
J6	JUNCTION	76.72	1.00	0.0	
J7	JUNCTION	76.33	1.00	0.0	
J8	JUNCTION	77.13	1.00	0.0	
J9	JUNCTION	76.09	1.91	0.0	
OF1	OUTFALL	77.70	0.00	0.0	
OF2_2_RizellDrain	OUTFALL	75.90	1.49	0.0	
BA	STORAGE	95.50	2.00	0.0	
BB	STORAGE	95.50	2.00	0.0	
OF2_1_WetPond	STORAGE	75.10	3.00	0.0	

Link Summary

Name	From Node	To Node	Type	Length	%Slope	Roughness
C1	J9	OF2_2_RizellDrain	CONDUIT	11.1	1.7054	0.0350
S1_1	J1	J8	CONDUIT	39.1	0.9572	0.0350
S1_2	J8	J3	CONDUIT	133.4	0.8566	0.0350
S2	J2	J4	CONDUIT	64.2	0.5453	0.0350
S3_1	J6	J7	CONDUIT	69.7	0.5555	0.0350
S3_2	J7	J5	CONDUIT	86.9	0.5561	0.0350
OR1	J3	OF2_1_WetPond	ORIFICE			
OR2	J4	OF2_1_WetPond	ORIFICE			
OR3	J5	OF2_1_WetPond	ORIFICE			
CI_1	OF2_1_WetPond	J9	WEIR			
W1	J3	OF2_1_WetPond	WEIR			

W2 J4 OF2_1_WetPond WEIR
W3 J5 OF2_1_WetPond WEIR
W4 OF2_1_WetPond J9 WEIR
OL2 BA J8 OUTLET
OL3 BB J7 OUTLET

Cross Section Summary

Conduit	Shape	Full Depth	Full Area	Hyd. Rad.	Max. Width	No. of Barrels	Full Flow
C1	Transect1	1.49	10.54	0.51	22.03	1	25.26
S1_1	TRAPEZOIDAL	1.00	3.75	0.53	6.75	1	6.87
S1_2	TRAPEZOIDAL	1.00	3.75	0.53	6.75	1	6.86
S2	TRAPEZOIDAL	1.00	3.75	0.53	6.75	1	5.18
S3_1	TRAPEZOIDAL	1.00	3.75	0.53	6.75	1	5.23
S3_2	TRAPEZOIDAL	1.00	3.75	0.53	6.75	1	5.23

Transect Summary

Area:	0.0004	0.0016	0.0037	0.0066	0.0103
	0.0148	0.0201	0.0261	0.0326	0.0398
	0.0475	0.0558	0.0646	0.0741	0.0841
	0.0947	0.1059	0.1177	0.1302	0.1434
	0.1572	0.1717	0.1868	0.2026	0.2189
	0.2359	0.2535	0.2716	0.2904	0.3099
	0.3302	0.3512	0.3730	0.3957	0.4193
	0.4438	0.4693	0.4958	0.5235	0.5525
	0.5838	0.6182	0.6557	0.6960	0.7395
	0.7867	0.8369	0.8897	0.9440	1.0000
Width:	0.0131	0.0263	0.0394	0.0525	0.0657
	0.0788	0.0905	0.1006	0.1098	0.1189
	0.1281	0.1372	0.1463	0.1555	0.1646
	0.1742	0.1846	0.1949	0.2054	0.2159
	0.2264	0.2369	0.2475	0.2571	0.2667
	0.2763	0.2859	0.2955	0.3063	0.3183
	0.3302	0.3425	0.3563	0.3701	0.3840
	0.4001	0.4168	0.4335	0.4533	0.4772
	0.5243	0.5769	0.6225	0.6678	0.7269
	0.7828	0.8252	0.8580	0.8811	1.0000

Area:	0.0004	0.0016	0.0037	0.0066	0.0103
	0.0148	0.0201	0.0261	0.0326	0.0398
	0.0475	0.0558	0.0646	0.0741	0.0841
	0.0947	0.1059	0.1177	0.1302	0.1434
	0.1572	0.1717	0.1868	0.2026	0.2189
	0.2359	0.2535	0.2716	0.2904	0.3099
	0.3302	0.3512	0.3730	0.3957	0.4193
	0.4438	0.4693	0.4958	0.5235	0.5525
	0.5838	0.6182	0.6557	0.6960	0.7395
	0.7867	0.8369	0.8897	0.9440	1.0000
Width:	0.0131	0.0263	0.0394	0.0525	0.0657
	0.0788	0.0905	0.1006	0.1098	0.1189
	0.1281	0.1372	0.1463	0.1555	0.1646
	0.1742	0.1846	0.1949	0.2054	0.2159
	0.2264	0.2369	0.2475	0.2571	0.2667
	0.2763	0.2859	0.2955	0.3063	0.3183
	0.3302	0.3425	0.3563	0.3701	0.3840
	0.4001	0.4168	0.4335	0.4533	0.4772
	0.5243	0.5769	0.6225	0.6678	0.7269
	0.7828	0.8252	0.8580	0.8811	1.0000

NOTE: The summary statistics displayed in this report are based on results found at every computational time step, not just on results from each reporting time step.

Analysis Options

Flow Units CMS
Process Models:
Rainfall/Runoff YES
RDI NO
Snowmelt NO
Groundwater NO
Flow Routing YES
Funding Allowed YES
Water Quality NO
Infiltration Method HORTON
Flow Routing Method DYNRAVE
Surcharge Method EXTRAN
Starting Date 11/10/2013 00:00:00
Ending Date 11/13/2013 00:00:00
Antecedent Dry Days 0.0
Report Time Step 00:05:00
Wet Time Step 00:05:00
Dry Time Step 00:05:00
Routing Time Step 1.00 sec
Variable Time Step YES
Maximum Trials 20
Number of Threads 2
Head Tolerance 0.001500 m

Runoff Quantity Continuity	Volume hectare-m	Depth mm
Total Precipitation	0.542	71.677
Evaporation Loss	0.000	0.000
Infiltration Loss	0.115	15.243
Surface Runoff	0.423	55.909
Final Storage	0.008	1.065
Continuity Error (%)	-0.753	

Flow Routing Continuity	Volume hectare-m	Volume 10 ⁶ ltr
Dry Weather Inflow	0.000	0.000
Wet Weather Inflow	0.423	4.229
Groundwater Inflow	0.000	0.000
RDI Inflow	0.000	0.000
External Inflow	0.000	0.000
External Outflow	0.418	4.182
Flooding Loss	0.000	0.000
Evaporation Loss	0.000	0.000
Exfiltration Loss	0.000	0.000
Initial Stored Volume	0.164	1.645
Final Stored Volume	0.171	1.708
Continuity Error (%)	-0.271	

Time-Step Critical Elements

None

Highest Flow Instability Indexes

Link W2 (20)
Link OR1 (14)
Link W3 (13)
Link OR3 (9)
Link OR2 (7)

Routing Time Step Summary	
Minimum Time Step	: 0.50 sec
Average Time Step	: 1.00 sec
Maximum Time Step	: 1.00 sec
Percent in Steady State	: 0.00
Average Iterations per Step	: 2.00
Percent Not Converging	: 0.00
Time Step Frequencies	:
1.000 - 0.871 sec	: 100.00 %
0.871 - 0.758 sec	: 0.00 %
0.758 - 0.660 sec	: 0.00 %
0.660 - 0.574 sec	: 0.00 %
0.574 - 0.500 sec	: 0.00 %

Subcatchment Runoff Summary

Subcatchment	Total Precip mm	Total Runon mm	Total Evap mm	Total Infil mm	Imperv Runoff mm	Perv Runoff mm	Total Runoff mm	Total Runoff 10 ⁶ ltr	Peak Runoff CMS	Runoff Coeff
Pond	71.68	0.00	0.00	0.00	71.67	0.00	71.67	0.20	0.14	1.000
S-BA	71.68	0.00	0.00	0.00	70.28	0.00	70.28	0.79	0.56	0.981
S-BB	71.68	0.00	0.00	0.01	70.27	0.01	70.27	0.50	0.36	0.980
S-BX	71.68	0.00	0.00	0.01	70.53	0.01	70.54	0.69	0.48	0.984
S-U1	71.68	0.00	0.00	38.92	10.85	22.33	33.18	0.20	0.16	0.463
S-U2	71.68	0.00	0.00	14.72	55.13	56.59	56.59	1.19	0.61	0.790
S-U3	71.68	0.00	0.00	5.90	64.75	65.32	65.32	0.37	0.25	0.911
S-U4	71.68	0.00	0.00	53.20	3.78	18.52	18.52	0.08	0.02	0.258
S-U5	71.68	0.00	0.00	44.25	3.52	28.19	28.19	0.05	0.04	0.393

S-U6	71.68	0.00	0.00	44.25	3.51	28.19	28.19	0.01	0.01	0.393
S-U7	71.68	0.00	0.00	45.03	3.76	27.16	27.16	0.10	0.07	0.379
S-U8	71.68	0.00	0.00	45.81	3.51	26.27	26.27	0.05	0.03	0.367

Node Depth Summary

Node	Type	Average Depth Meters	Maximum Depth Meters	Maximum HGL Meters	Time of Max Occurrence days hr:min	Reported Max Depth Meters
J1	JUNCTION	0.00	0.11	77.61	0 01:10	0.11
J10	JUNCTION	0.00	0.00	0.00	0 00:00	0.00
J2	JUNCTION	0.02	0.46	76.66	0 01:18	0.46
J3	JUNCTION	0.32	0.65	76.50	0 01:45	0.65
J4	JUNCTION	0.32	0.77	76.62	0 01:19	0.77
J5	JUNCTION	0.32	0.65	76.50	0 01:45	0.65
J6	JUNCTION	0.00	0.26	76.98	0 01:15	0.26
J7	JUNCTION	0.01	0.27	76.61	0 01:16	0.27
J8	JUNCTION	0.01	0.14	77.26	0 01:14	0.14
J9	JUNCTION	0.05	0.26	76.35	0 01:45	0.26
OF1	OUTFALL	0.00	0.00	77.70	0 00:00	0.00
OF2_2_KizellDrain	OUTFALL	0.04	0.24	76.14	0 01:45	0.24
BA	STORAGE	0.02	0.25	95.75	0 02:00	0.25
BB	STORAGE	0.01	0.23	95.73	0 01:44	0.23
OF2_1_WetPond	STORAGE	1.07	1.40	76.50	0 01:45	1.40

Node Inflow Summary

Node	Type	Maximum Lateral Inflow CMS	Maximum Total Inflow CMS	Time of Max Occurrence days hr:min	Lateral Inflow Volume 10 ⁶ ltr	Total Inflow Volume 10 ⁶ ltr	Flow Balance Error Percent
J1	JUNCTION	0.068	0.068	0 01:10	0.102	0.102	-0.055
J10	JUNCTION	0.000	0.000	0 00:00	0	0	0.000 ltr
J2	JUNCTION	0.646	0.646	0 01:15	1.25	1.25	-0.198
J3	JUNCTION	0.000	0.094	0 01:14	0	0.895	0.387
J4	JUNCTION	0.000	0.612	0 01:15	0	1.25	0.371
J5	JUNCTION	0.000	0.283	0 01:16	0	0.953	0.514
J6	JUNCTION	0.268	0.268	0 01:15	0.443	0.443	-0.143
J7	JUNCTION	0.000	0.293	0 01:15	0	0.95	-0.268
J8	JUNCTION	0.000	0.100	0 01:10	0	0.893	-0.258
J9	JUNCTION	0.000	0.310	0 01:45	0	3.3	0.001
OF1	OUTFALL	0.637	0.637	0 01:10	0.882	0.882	0.000
OF2_2_KizellDrain	OUTFALL	0.000	0.310	0 01:45	0	3.3	0.000
BA	STORAGE	0.557	0.557	0 01:10	0.789	0.789	-0.217
BB	STORAGE	0.356	0.356	0 01:10	0.505	0.505	-0.300
OF2_1_WetPond	STORAGE	0.178	0.932	0 01:17	0.263	4.95	0.044

Node Surcharge Summary

Surcharging occurs when water rises above the top of the highest conduit.

Node	Type	Hours Surcharged	Max. Height Above Crown Meters	Min. Depth Below Rim Meters
J10	JUNCTION	72.00	0.000	0.000

Node Flooding Summary

No nodes were flooded.

Storage Volume Summary

Storage Unit	Average Volume 1000 m3	Avg Full	Evap Pent	Exfil Pent	Maximum Volume 1000 m3	Max Full	Time of Max Occurrence days hr:min	Maximum Outflow CMS
BA	0.029	0	0	0	0.541	1	0 02:00	0.034
BB	0.014	0	0	0	0.324	0	0 01:44	0.028
OF2_1_WetPond	1.769	8	0	0	2.719	12	0 01:45	0.310

Outfall Loading Summary

Outfall Node	Flow Freq Pent	Avg Flow CMS	Max Flow CMS	Total Flow Volume 10 ⁶ ltr
OF1	7.10	0.048	0.637	0.882
OF2_2_KizellDrain	98.99	0.013	0.310	3.300
System	53.05	0.061	0.641	4.182

Link Flow Summary

Link	Type	Maximum Flow CMS	Time of Max Occurrence days hr:min	Maximum Veloc #/sec	Max/ Full Flow	Max/ Full Depth
C1	CHANNEL	0.310	0 01:45	1.03	0.01	0.17
SL_1	CONDUIT	0.066	0 01:10	0.50	0.01	0.12
SL_2	CONDUIT	0.094	0 01:14	0.22	0.01	0.37
S2	CONDUIT	0.612	0 01:15	0.43	0.12	0.62
S3_1	CONDUIT	0.264	0 01:15	0.64	0.05	0.27
S3_2	CONDUIT	0.283	0 01:16	0.34	0.05	0.43
OR1	ORIFICE	0.018	0 01:05			1.00
OR2	ORIFICE	0.076	0 01:15			1.00
OR3	ORIFICE	0.048	0 01:14			1.00
CL_1	WEIR	0.008	0 01:45			1.00
W1	WEIR	0.046	0 01:36			0.34
W2	WEIR	0.502	0 01:17			0.46
W3	WEIR	0.205	0 01:17			0.34
W4	WEIR	0.302	0 01:45			0.41
OL2	DUMMY	0.034	0 01:03			
OL3	DUMMY	0.028	0 01:05			

Flow Classification Summary

Conduit	Adjusted /Actual Length	Up Dry	Down Dry	Sub	Fraction of Time in Flow Class	Sup Crit	Up Crit	Down Crit	Norm Crit	Inlet Ltd	Inlet Ctrl
C1	1.00	0.00	0.00	0.00	0.99	0.00	0.00	0.00	0.00	0.00	0.00
SL_1	1.00	0.00	0.93	0.00	0.07	0.00	0.00	0.00	0.00	0.99	0.00
SL_2	1.00	0.00	0.00	0.00	1.00	0.00	0.00	0.00	0.00	1.00	0.00
S2	1.00	0.00	0.67	0.00	0.33	0.00	0.00	0.00	0.00	0.80	0.00
S3_1	1.00	0.00	0.85	0.00	0.14	0.00	0.00	0.00	0.00	0.99	0.00
S3_2	1.00	0.00	0.00	0.00	1.00	0.00	0.00	0.00	0.00	0.98	0.00

Conduit Surcharge Summary

No conduits were surcharged.

Analysis begun on: Fri Jan 20 11:02:38 2023
Analysis ended on: Fri Jan 20 11:02:42 2023
Total elapsed time: 00:00:04

100-year Post-Development with 100-year Fixed Tailwater

EPA STORM WATER MANAGEMENT MODEL - VERSION 5.1 (Build 5.1.015)

WARNING 02: maximum depth increased for Node J1
 WARNING 02: maximum depth increased for Node J3
 WARNING 02: maximum depth increased for Node J4
 WARNING 02: maximum depth increased for Node J5
 WARNING 02: maximum depth increased for Node J8

 Element Count

 Number of rain gages 16
 Number of subcatchments ... 12
 Number of nodes 15
 Number of links 16
 Number of pollutants 0
 Number of land uses 0

 Rainage Summary

Name	Data Source	Data Type	Recording Interval
100yr_3hr_Chicago	100yr_3hr_Chicago	INTENSITY	10 min.
100yr_3hr_Chicago_Climate_Change	100yr_3hr_Chicago_Increase_20percent	INTENSITY	10 min.
100yr_6hr_Chicago	100yr_6hr_Chicago	INTENSITY	10 min.
100yr_6hr_Chicago_Climate_Change	100yr_6hr_Chicago_Increase_20percent	INTENSITY	10 min.
10yr_3hr_Chicago	10yr_3hr_Chicago	INTENSITY	10 min.
10yr_6hr_Chicago	10yr_6hr_Chicago	INTENSITY	10 min.
25mm_3hr_Chicago	25mm_3hr_Chicago	INTENSITY	10 min.
25mm_6hr_Chicago	25mm_6hr_Chicago	INTENSITY	10 min.
25yr_3hr_Chicago	25yr_3hr_Chicago	INTENSITY	10 min.
25yr_6hr_Chicago	25yr_6hr_Chicago	INTENSITY	10 min.
2yr_3hr_Chicago	2yr_3hr_Chicago	INTENSITY	10 min.
2yr_6hr_Chicago	2yr_6hr_Chicago	INTENSITY	10 min.
50yr_3hr_Chicago	50yr_3hr_Chicago	INTENSITY	10 min.
50yr_6hr_Chicago	50yr_6hr_Chicago	INTENSITY	10 min.
5yr_3hr_Chicago	5yr_3hr_Chicago	INTENSITY	10 min.
5yr_6hr_Chicago	5yr_6hr_Chicago	INTENSITY	10 min.

 Subcatchment Summary

Name	Area	Width	%Imperv	%Slope	Rain Gage	Outlet
Pond	0.28	27550.00	100.00	3.3690	100yr_3hr_Chicago	OF2_1_WetPond
S-BA	1.12	660.53	100.00	2.0000	100yr_3hr_Chicago	BA
S-BB	0.72	422.71	99.98	2.0000	100yr_3hr_Chicago	BB
S-BEX	0.97	221.34	99.97	2.0000	100yr_3hr_Chicago	OF1
S-U1	0.59	125.57	15.46	4.9330	100yr_3hr_Chicago	OF1
S-U2	2.11	70.80	77.97	2.0000	100yr_3hr_Chicago	J2
S-U3	0.66	54.08	91.54	0.6000	100yr_3hr_Chicago	J6
S-U4	0.41	31.45	5.39	0.6000	100yr_3hr_Chicago	J6
S-U5	0.18	73.32	5.00	2.0000	100yr_3hr_Chicago	J2
S-U6	0.05	19.04	5.00	2.0000	100yr_3hr_Chicago	OF2_1_WetPond
S-U7	0.37	98.63	5.36	2.0000	100yr_3hr_Chicago	J1
S-U8	0.20	41.38	5.00	2.0000	100yr_3hr_Chicago	OF2_1_WetPond

 Node Summary

Name	Type	Invert Elev.	Max. Depth	Ponded Area	External Inflow
J1	JUNCTION	77.50	1.00	0.0	
J10	JUNCTION	0.00	0.00	0.0	
J2	JUNCTION	76.20	1.00	0.0	
J3	JUNCTION	75.85	1.31	0.0	
J4	JUNCTION	75.85	1.31	0.0	
J5	JUNCTION	75.85	1.31	0.0	
J6	JUNCTION	76.72	1.00	0.0	
J7	JUNCTION	76.33	1.00	0.0	
J8	JUNCTION	77.13	1.00	0.0	
J9	JUNCTION	76.09	1.91	0.0	
OF1	OUTFALL	77.70	0.00	0.0	
OF2_2_RizellDrain	OUTFALL	75.90	1.49	0.0	
BA	STORAGE	95.50	2.00	0.0	
BB	STORAGE	95.50	2.00	0.0	
OF2_1_WetPond	STORAGE	75.10	3.00	0.0	

 Link Summary

Name	From Node	To Node	Type	Length	%Slope	Roughness
C1	J9	OF2_2_RizellDrain	CONDUIT	11.1	1.7054	0.0350
S1	J8	J3	CONDUIT	39.1	0.9572	0.0350
SL_2	J8	J3	CONDUIT	133.4	0.9566	0.0350
S2	J2	J4	CONDUIT	64.2	0.5453	0.0350
S3_1	J6	J7	CONDUIT	69.7	0.5555	0.0350
S3_2	J7	J5	CONDUIT	86.9	0.5561	0.0350
OR1	J3	OF2_1_WetPond	ORIFICE			
OR2	J4	OF2_1_WetPond	ORIFICE			
OR3	J5	OF2_1_WetPond	ORIFICE			
CL_1	OF2_1_WetPond	J9	WEIR			
W1	J3	OF2_1_WetPond	WEIR			

W2	J4	OF2_1_WetPond	WEIR
W3	J5	OF2_1_WetPond	WEIR
W4	J9	OF2_1_WetPond	WEIR
OL2	BA	J8	OUTLET
OL3	BB	J7	OUTLET

 Cross Section Summary

Conduit	Shape	Full Depth	Full Area	Hyd. Rad.	Max. Width	No. of Barrels	Full Flow
C1	Transect1	1.49	10.54	0.51	22.03	1	25.26
S1_1	TRAPEZOIDAL	1.00	3.75	0.53	6.75	1	6.87
S1_2	TRAPEZOIDAL	1.00	3.75	0.53	6.75	1	6.86
S2	TRAPEZOIDAL	1.00	3.75	0.53	6.75	1	5.18
S3_1	TRAPEZOIDAL	1.00	3.75	0.53	6.75	1	5.23
S3_2	TRAPEZOIDAL	1.00	3.75	0.53	6.75	1	5.23

 Transect Summary

Transect Area:	Transect1	0.0004	0.0016	0.0037	0.0066	0.0103
		0.0148	0.0201	0.0261	0.0326	0.0398
		0.0475	0.0558	0.0646	0.0741	0.0841
		0.0947	0.1059	0.1177	0.1302	0.1434
		0.1572	0.1717	0.1868	0.2026	0.2189
		0.2359	0.2535	0.2716	0.2904	0.3099
		0.3302	0.3512	0.3730	0.3957	0.4193
		0.4438	0.4693	0.4958	0.5235	0.5525
		0.5838	0.6182	0.6557	0.6960	0.7395
		0.7867	0.8369	0.8897	0.9440	1.0000
Width:		0.0283	0.0566	0.0849	0.1132	0.1415
		0.1698	0.2008	0.2341	0.2683	0.3015
		0.3339	0.3656	0.3968	0.4277	0.4581
		0.5162	0.5142	0.5143	0.5143	0.5143
		0.6221	0.6493	0.6764	0.7057	0.7351
		0.7644	0.7936	0.8227	0.8487	0.8719
		0.8954	0.9185	0.9383	0.9587	0.9797
		0.9957	1.0114	1.0281	1.0389	1.0427
		1.0049	0.9690	0.9539	0.9451	0.9240
		0.9138	0.9228	0.9436	0.9738	1.0000
Width:		0.0131	0.0263	0.0394	0.0525	0.0657
		0.0788	0.0905	0.1006	0.1098	0.1189
		0.1281	0.1372	0.1463	0.1555	0.1646
		0.1742	0.1846	0.1949	0.2054	0.2159
		0.2264	0.2369	0.2475	0.2571	0.2667
		0.2763	0.2859	0.2955	0.3063	0.3183
		0.4001	0.4168	0.4335	0.4533	0.4772
		0.5243	0.5769	0.6225	0.6678	0.7269
		0.7828	0.8252	0.8580	0.8811	1.0000
Transect Area:	Transect2	0.0004	0.0016	0.0037	0.0066	0.0103
		0.0148	0.0201	0.0261	0.0326	0.0398
		0.0475	0.0558	0.0646	0.0741	0.0841
		0.0947	0.1059	0.1177	0.1302	0.1434
		0.1572	0.1717	0.1868	0.2026	0.2189
		0.2359	0.2535	0.2716	0.2904	0.3099
		0.3302	0.3512	0.3730	0.3957	0.4193
		0.4438	0.4693	0.4958	0.5235	0.5525
		0.5838	0.6182	0.6557	0.6960	0.7395
		0.7867	0.8369	0.8897	0.9440	1.0000
Width:		0.0311	0.0622	0.0933	0.1244	0.1555
		0.1867	0.2208	0.2574	0.2950	0.3315
		0.3671	0.4020	0.4363	0.4702	0.5037
		0.5357	0.5653	0.5951	0.6247	0.6543
		0.6840	0.7138	0.7437	0.7759	0.8082
		0.8404	0.8725	0.9045	0.9331	0.9586
		0.9845	1.0099	1.0316	1.0540	1.0771
		1.0948	1.1120	1.1304	1.1422	1.1464
		1.1049	1.0653	1.0488	1.0391	1.0159
		1.0047	1.0146	1.0374	1.0706	1.0000
Width:		0.0131	0.0263	0.0394	0.0525	0.0657
		0.0788	0.0905	0.1006	0.1098	0.1189
		0.1281	0.1372	0.1463	0.1555	0.1646
		0.1742	0.1846	0.1949	0.2054	0.2159
		0.2264	0.2369	0.2475	0.2571	0.2667
		0.2763	0.2859	0.2955	0.3063	0.3183
		0.3302	0.3425	0.3563	0.3701	0.3840
		0.4001	0.4168	0.4335	0.4533	0.4772
		0.5243	0.5769	0.6225	0.6678	0.7269
		0.7828	0.8252	0.8580	0.8811	1.0000

 NOTE: The summary statistics displayed in this report are based on results found at every computational time step, not just on results from each reporting time step.

 Analysis Options

Flow Units CMS
 Process Models:
 Rainfall/Runoff YES
 RDII NO
 Snowmelt NO
 Groundwater NO
 Flow Routing YES
 Flooding Allowed YES
 Water Quality NO
 Infiltration Method HORTON
 Flow Routing Method DYNWAVE
 Surcharge Method EXTRAN
 Starting Date 11/10/2013 00:00:00
 Ending Date 11/13/2013 00:00:00
 Antecedent Dry Days 0.0
 Report Time Step 00:05:00
 Wet Time Step 00:05:00
 Dry Time Step 00:05:00
 Routing Time Step 1.00 sec
 Variable Time Step YES
 Maximum Trials 20
 Number of Threads 2
 Head Tolerance 0.001500 m

	Volume	Depth
	hectare-m	mm
Runoff Quantity Continuity	-----	-----
Total Precipitation	0.542	71.677
Evaporation Loss	0.000	0.000
Infiltration Loss	0.115	15.243
Surface Runoff	0.423	55.909
Final Storage	0.008	1.065
Continuity Error (%)	-0.753	

	Volume	Volume
	hectare-m	10 ⁶ ltr
Flow Routing Continuity	-----	-----
Dry Weather Inflow	0.000	0.000
Wet Weather Inflow	0.423	4.229
Groundwater Inflow	0.000	0.000
RDII Inflow	0.000	0.000
External Inflow	0.000	0.003
External Outflow	0.423	4.234
Flooding Loss	0.000	0.000
Evaporation Loss	0.000	0.000
Exfiltration Loss	0.000	0.000
Initial Stored Volume	0.295	2.948
Final Stored Volume	0.301	3.014
Continuity Error (%)	-0.931	

Time-Step Critical Elements
 None

Highest Flow Instability Indexes

Link W2 (144)
 Link W3 (139)
 Link W4 (137)
 Link W1 (137)
 Link Cl_1 (135)

Routing Time Step Summary

Minimum Time Step	: 0.50 sec
Average Time Step	: 1.00 sec
Maximum Time Step	: 1.00 sec
Percent in Steady State	: 0.00
Average Iterations per Step	: 2.00
Percent Not Converging	: 0.00
Time Step Frequencies	:
1.000 - 0.871 sec	: 100.00 %
0.871 - 0.758 sec	: 0.00 %
0.758 - 0.660 sec	: 0.00 %
0.660 - 0.574 sec	: 0.00 %
0.574 - 0.500 sec	: 0.00 %

Subcatchment Runoff Summary

Subcatchment	Total Precip mm	Total Runon mm	Total Evap mm	Total Infil mm	Imperv Runoff mm	Perv Runoff mm	Total Runoff mm	Total Runoff 10 ⁶ ltr	Peak Runoff CMS	Runoff Coeff
Pond	71.68	0.00	0.00	0.00	71.67	0.00	71.67	0.20	0.14	1.000
S-BA	71.68	0.00	0.00	0.00	70.28	0.00	70.28	0.79	0.56	0.981
S-BB	71.68	0.00	0.00	0.01	70.27	0.01	70.27	0.50	0.36	0.980
S-BEX	71.68	0.00	0.00	0.01	70.53	0.01	70.54	0.69	0.48	0.984
S-U1	71.68	0.00	0.00	38.92	10.85	22.33	33.18	0.20	0.16	0.463
S-U2	71.68	0.00	0.00	14.72	55.13	56.59	56.59	1.19	0.61	0.790
S-U3	71.68	0.00	0.00	5.90	64.75	65.32	65.32	0.37	0.25	0.911
S-U4	71.68	0.00	0.00	53.20	3.78	18.52	18.52	0.08	0.02	0.258
S-U5	71.68	0.00	0.00	44.25	3.52	28.19	28.19	0.05	0.04	0.393

S-U6	71.68	0.00	0.00	44.25	3.51	28.19	28.19	0.01	0.01	0.393
S-U7	71.68	0.00	0.00	45.03	3.76	27.16	27.16	0.10	0.07	0.379
S-U8	71.68	0.00	0.00	45.81	3.51	26.27	26.27	0.05	0.03	0.367

Node Depth Summary

Node	Type	Average Depth Meters	Maximum Depth Meters	Maximum HGL Meters	Time of Max Occurrence days hr:min	Reported Max Depth Meters
J1	JUNCTION	0.00	0.11	77.61	0 01:10	0.11
J10	JUNCTION	0.00	0.00	0.00	0 00:00	0.00
J2	JUNCTION	0.30	0.56	76.76	0 01:18	0.55
J3	JUNCTION	0.65	0.79	76.64	0 01:34	0.79
J4	JUNCTION	0.65	0.89	76.74	0 01:18	0.89
J5	JUNCTION	0.65	0.79	76.64	0 01:34	0.79
J6	JUNCTION	0.00	0.26	76.98	0 01:15	0.26
J7	JUNCTION	0.17	0.31	76.65	0 01:33	0.31
J8	JUNCTION	0.01	0.14	77.26	0 01:14	0.14
J9	JUNCTION	0.41	0.42	76.51	0 01:34	0.42
OF1	OUTFALL	0.00	0.00	77.70	0 00:00	0.00
OF2_2_KizellDrain	OUTFALL	0.60	0.60	76.50	0 00:00	0.60
BA	STORAGE	0.02	0.25	95.75	0 02:00	0.25
BB	STORAGE	0.01	0.23	95.73	0 01:44	0.23
OF2_1_WetPond	STORAGE	1.40	1.54	76.64	0 01:34	1.54

Node Inflow Summary

Node	Type	Maximum Lateral Inflow CMS	Maximum Total Inflow CMS	Time of Max Occurrence days hr:min	Lateral Inflow Volume 10 ⁶ ltr	Total Inflow Volume 10 ⁶ ltr	Flow Balance Error Percent
J1	JUNCTION	0.068	0.068	0 01:10	0.102	0.102	-0.064
J10	JUNCTION	0.000	0.000	0 00:00	0	0	0.000 ltr
J2	JUNCTION	0.646	0.646	0 01:15	1.25	1.25	-0.017
J3	JUNCTION	0.000	0.092	0 01:15	0	0.896	0.342
J4	JUNCTION	0.000	0.610	0 01:15	0	1.26	0.108
J5	JUNCTION	0.000	0.266	0 01:16	0	0.969	0.157
J6	JUNCTION	0.268	0.268	0 01:15	0.443	0.443	-0.226
J7	JUNCTION	0.000	0.292	0 01:15	0	0.964	0.127
J8	JUNCTION	0.000	0.100	0 01:10	0	0.893	-0.005
J9	JUNCTION	0.000	0.466	0 01:34	0	3.35	-0.309
OF1	OUTFALL	0.637	0.637	0 01:10	0.882	0.882	0.000
OF2_2_KizellDrain	OUTFALL	0.000	0.466	0 01:34	0	3.36	0.000
BA	STORAGE	0.557	0.557	0 01:10	0.789	0.789	-0.217
BB	STORAGE	0.356	0.356	0 01:10	0.505	0.505	-0.300
OF2_1_WetPond	STORAGE	0.178	0.951	0 01:17	0.263	6.08	0.101

Node Surcharge Summary

Surcharging occurs when water rises above the top of the highest conduit.

Node	Type	Hours Surcharged	Max. Height Above Crown Meters	Min. Depth Below Rim Meters
J10	JUNCTION	72.00	0.000	0.000

Node Flooding Summary

No nodes were flooded.

Storage Volume Summary

Storage Unit	Average Volume 1000 m3	Avg Full	Evap Loss	Exfil Loss	Maximum Volume 1000 m3	Max Full	Time of Max Occurrence days hr:min	Maximum Outflow CMS
BA	0.029	0	0	0	0.541	1	0 02:00	0.034
BB	0.014	0	0	0	0.324	0	0 01:44	0.028
OF2_1_WetPond	2.731	12	0	0	3.394	15	0 01:34	0.466

Outfall Loading Summary

Outfall Node	Flow Free Flow	Avg Flow CMS	Max Flow CMS	Total Flow Volume 10 ⁶ ltr
OF1	7.10	0.048	0.637	0.882
OF2_2_KizellDrain	99.88	0.013	0.466	3.356
System	53.49	0.061	0.840	4.237

 Link Flow Summary

Link	Type	Maximum Flow CMS	Time of Max Occurrence days hr:min	Maximum Veloc m/sec	Max/ Full Flow	Max/ Full Depth
C1	CHANNEL	0.466	0 01:34	0.41	0.02	0.34
S1_1	CONDUIT	0.966	0 01:10	0.51	0.01	0.12
S1_2	CONDUIT	0.092	0 01:15	0.11	0.01	0.45
S2	CONDUIT	0.610	0 01:15	0.30	0.12	0.72
S3_1	CONDUIT	0.264	0 01:15	0.61	0.05	0.28
S3_2	CONDUIT	0.266	0 01:16	0.22	0.05	0.55
OR1	ORIFICE	0.004	0 01:13			1.00
OR2	ORIFICE	0.054	0 01:16			1.00
OR3	ORIFICE	0.024	0 01:16			1.00
CL1	WEIR	0.007	0 01:34			1.00
W1	WEIR	0.059	0 01:24			0.48
W2	WEIR	0.526	0 01:17			0.58
W3	WEIR	0.218	0 01:16			0.48
W4	WEIR	0.459	0 01:34			0.62
OL2	DUMMY	0.034	0 01:03			
OL3	DUMMY	0.028	0 01:05			

 Flow Classification Summary

Conduit	Adjusted /Actual Length	Up		Down		Sub		Sup		Up		Down		Norm Inlet Ctrl
		Dry	Dry	Dry	Crit	Crit	Crit	Crit	Crit	Crit	Crit	Crit	Crit	
C1	1.00	0.00	0.00	0.00	1.00	0.00	0.00	0.00	0.00	0.00	0.00	0.00	0.00	0.00
S1_1	1.00	0.00	0.93	0.00	0.07	0.00	0.00	0.00	0.00	0.99	0.00			
S1_2	1.00	0.00	0.00	0.00	1.00	0.00	0.00	0.00	0.00	1.00	0.00			
S2	1.00	0.00	0.00	0.00	1.00	0.00	0.00	0.00	0.00	0.00	0.00			
S3_1	1.00	0.00	0.83	0.00	0.17	0.00	0.00	0.00	0.00	0.99	0.00			
S3_2	1.00	0.00	0.00	0.00	1.00	0.00	0.00	0.00	0.00	0.00	0.00			

 Conduit Surcharge Summary

No conduits were surcharged.

Analysis begun on: Fri Jan 20 11:04:10 2023
 Analysis ended on: Fri Jan 20 11:04:15 2023
 Total elapsed time: 00:00:05

APPENDIX







D

MVCA

FLOODPLAIN

MAP

Legend

- Parcels - Assessment
-  Meander Belt
-  1:100 yr Flood Plain
-  Floodplain Spill Lines
-  Floodplain Study Limit
-  MVCA Regulation Limit
-  MVCA Streams
-  Ottawa_Subcatchments

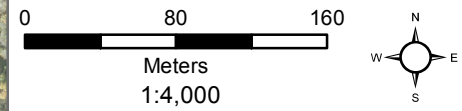

Projection: UTM Zone 18- NAD 83 Datum

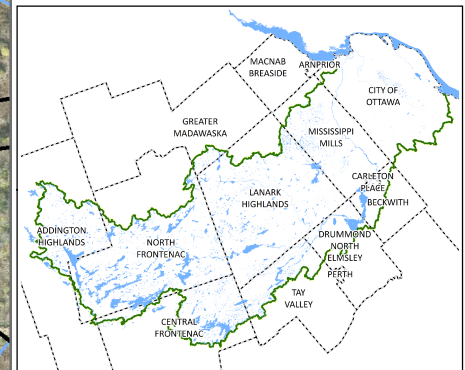

This map is produced in part with data provided by the Ontario Geographic Data Exchange under License with the Ontario Ministry of Natural Resources and the Queen's Printer for Ontario, 2019

Imagery @ Fugro Geospatial, May 2014

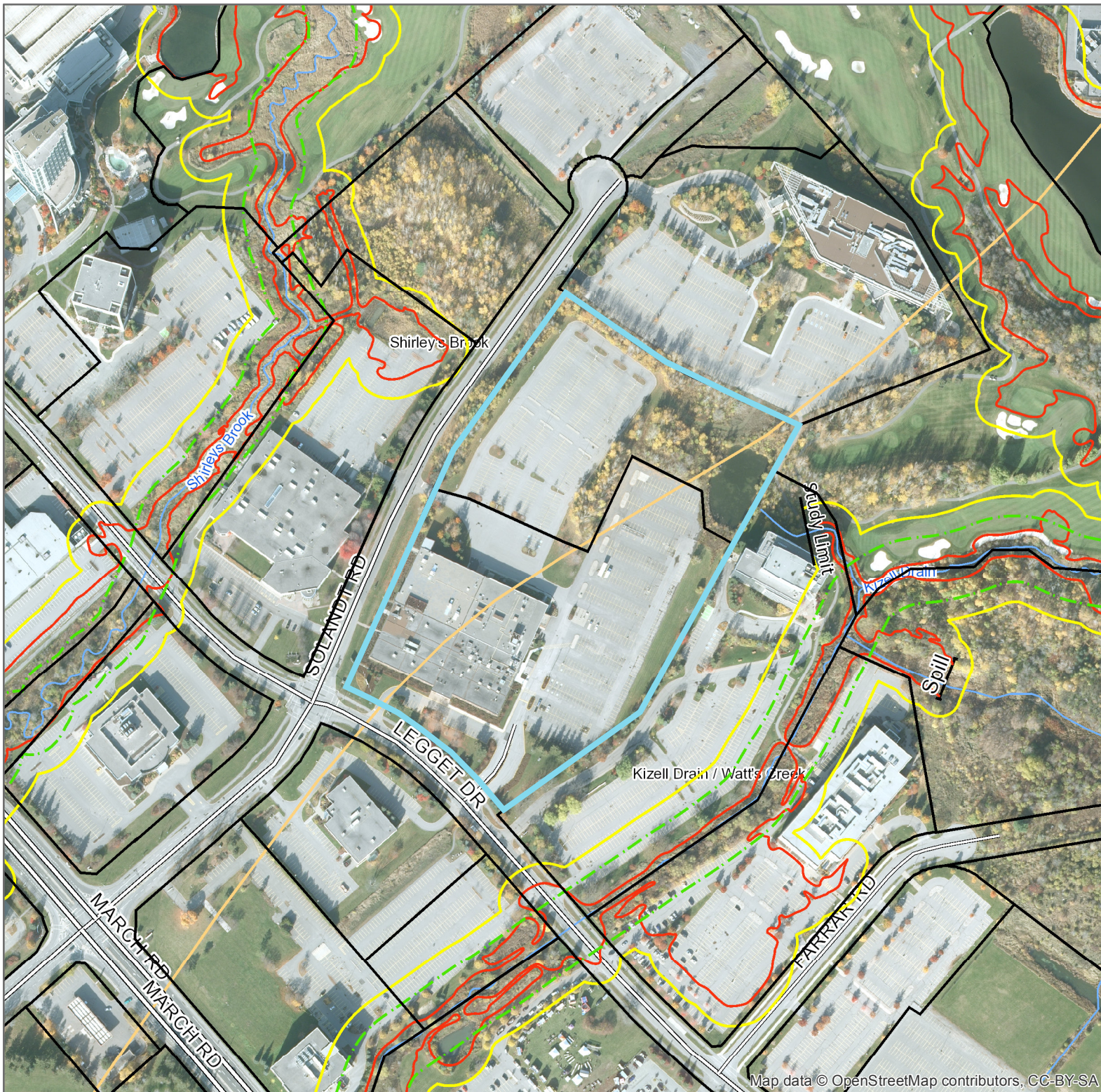

Map data © OpenStreetMap contributors, CC-BY-SA

APPENDIX

E SUPPORTING DOCUMENTS





Adjustable Accutrol Weir

Tag: _____

Adjustable Flow Control for Roof Drains

ADJUSTABLE ACCUTROL (for Large Sump Roof Drains only)

For more flexibility in controlling flow with heads deeper than 2", Watts Drainage offers the Adjustable Accutrol. The Adjustable Accutrol Weir is designed with a single parabolic opening that can be covered to restrict flow above 2" of head to less than 5 gpm per inch, up to 6" of head. To adjust the flow rate for depths over 2" of head, set the slot in the adjustable upper cone according to the flow rate required. Refer to Table 1 below.
 Note: Flow rates are directly proportional to the amount of weir opening that is exposed.

EXAMPLE:

For example, if the adjustable upper cone is set to cover 1/2 of the weir opening, flow rates above 2" of head will be restricted to 2-1/2 gpm per inch of head.

Therefore, at 3" of head, the flow rate through the Accutrol Weir that has 1/2 the slot exposed will be:
 [5 gpm (per inch of head) x 2 inches of head] + 2-1/2 gpm (for the third inch of head) = 12-1/2 gpm.

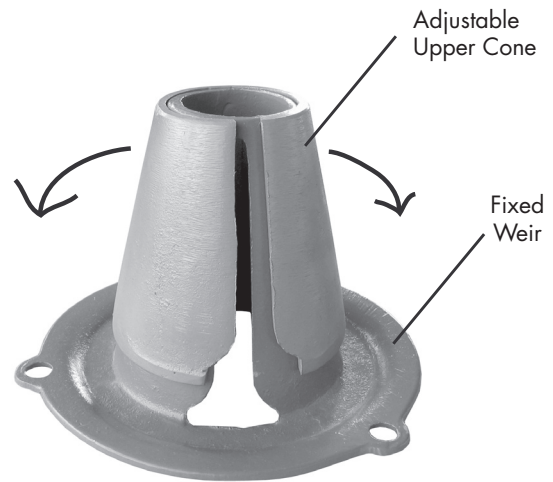
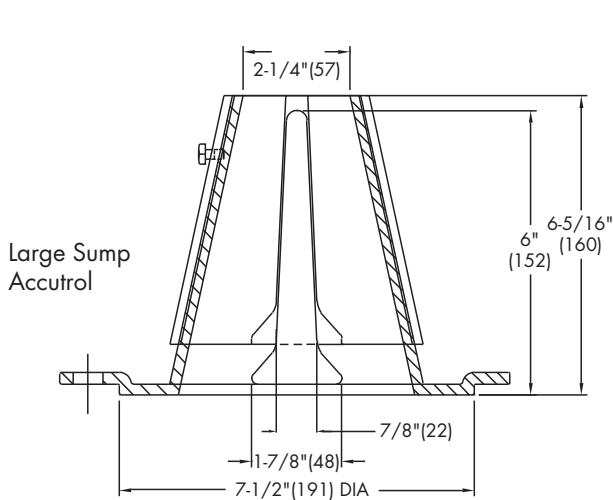

1/2 Weir Opening Exposed Shown Above

TABLE 1. Adjustable Accutrol Flow Rate Settings

Weir Opening Exposed	1"	2"	3"	4"	5"	6"
	Flow Rate (gallons per minute)					
Fully Exposed	5	10	15	20	25	30
3/4	5	10	13.75	17.5	21.25	25
1/2	5	10	12.5	15	17.5	20
1/4	5	10	11.25	12.5	13.75	15
Closed	5	5	5	5	5	5

Job Name _____
 Job Location _____
 Engineer _____

Contractor _____
 Contractor's P.O. No. _____
 Representative _____

Watts product specifications in U.S. customary units and metric are approximate and are provided for reference only. For precise measurements, please contact Watts Technical Service. Watts reserves the right to change or modify product design, construction, specifications, or materials without prior notice and without incurring any obligation to make such changes and modifications on Watts products previously or subsequently sold.

USA: Tel: (800) 338-2581 • Fax: (828) 248-3929 • Watts.com
 Canada: Tel: (905) 332-4090 • Fax: (905) 332-7068 • Watts.ca
 Latin America: Tel: (52) 81-1001-8600 • Fax: (52) 81-8000-7091 • Watts.com

