

VIPER Area/Site

VIPER LUMINAIRE

MICRO STRIKE | STRIKE OPTICS

FEATURES

- Low profile LED area/site luminaire with a variety of IES distributions for lighting applications such as auto dealership, retail, commercial, and campus parking lots
- Featuring two different optical technologies, Strike and Micro Strike Optics, which provide the best distribution patterns for retrofit or new construction
- Rated for high vibration applications including bridges and overpasses. All sizes are rated for 1.5G
- Control options including photo control, occupancy sensing, NX Lighting Controls™, wiSCAPE and 7-Pin with networked controls
- New customizable lumen output feature allows for the wattage and lumen output to be customized in the factory to meet whatever specification requirements may entail
- Field interchangeable mounting provides additional flexibility after the fixture has shipped



CONTROL TECHNOLOGY



SPECIFICATIONS

CONSTRUCTION

- Die-cast housing with hidden vertical heat fins are optimal for heat dissipation while keeping a clean smooth outer surface
- Corrosion resistant, die-cast aluminum housing with 1000 hour powder coat paint finish
- External hardware is corrosion resistant

OPTICS

- Micro Strike Optics (160, 320, 480, or 720 LED counts) maximize uniformity in applications and come standard with mid-power LEDs which evenly illuminate the entire luminous surface area to provide a low glare appearance. Catalog logic found on page 2
- Strike Optics (36, 72, 108, or 162 LED counts) provide best in class distributions and maximum pole spacing in new applications with high powered LEDs. Strike optics are held in place with a polycarbonate bezel to mimic the appearance of the Micro Strike Optics so both solutions can be combined on the same application. Catalog logic found on page 3
- Both optics maximize target zone illumination with minimal losses at the house-side, reducing light trespass issues. Additional backlight control shields and house side shields can be added for further reduction of illumination behind the pole
- One-piece silicone gasket ensures a weatherproof seal
- Zero up-light at 0 degrees of tilt
- Field rotatable optics

INSTALLATION

- Mounting patterns for each arm can be found on page 11
- Optional universal mounting block for ease of installation during retrofit applications. Available as an option (ASQU) or accessory for square and round poles
- All mounting hardware included

INSTALLATION (CONTINUED)

- Knuckle arm fitter option available for 2-3/8" OD tenon
- For products with EPA less than 1 mounted to a pole greater than 20ft, a vibration damper is recommended

ELECTRICAL

- Universal 120-277 VAC or 347-480 VAC input voltage, 50/60 Hz
- Ambient operating temperature -40°C to 40°C
- Drivers have greater than 90% power factor and less than 20% THD
- LED drivers have output power over-voltage, over-current protection and short circuit protection with auto recovery
- Field replaceable surge protection device provides 20kA protection meeting ANSI/IEEE C62.41.2 Category C High and Surge Location Category C3; Automatically takes fixture off-line for protection when device is compromised
- Dual Driver option provides 2 drivers within luminaire but only one set of leads exiting the luminaire, where Dual Power Feed provides two drivers which can be wired independently as two sets of leads are extended from the luminaire. Both options cannot be combined

CONTROLS

- Photo control, occupancy sensor programmable controls, and Zigbee wireless controls available for complete on/off and dimming control
- Please consult brand or sales representative when combining control and electrical options as some combinations may not operate as anticipated depending on your application
- 7-pin ANSI C136.41-2013 photocontrol receptacle option available for twist lock photocontrols or wireless control modules (control accessories sold separately)

CONTROLS (CONTINUED)

- 0- 10V Dimming Drivers are standard and dimming leads are extended out of the luminaire unless control options require connection to the dimming leads. Must specify if wiring leads are to be greater than the 6" standard
- NX Lighting Controls™ available with in fixture wireless control module, features dimming and occupancy sensor
- wiSCAPE® available with in fixture wireless control module, features dimming and occupancy sensor. Also available in 7-pin configuration

CERTIFICATIONS

- DLC® (DesignLights Consortium Qualified), with both Premium and Standard Qualified configurations. Please refer to the DLC website for specific product qualifications at <http://www.designlights.org>
- Listed to UL1598 and CSA C22.2#250.0-24 for wet locations and 40°C ambient temperatures
- 1.5 G rated for ANSI C136.31 high vibration applications
- Fixture is IP65 rated
- Meets IDA recommendations using 3K CCT configuration at 0 degrees of tilt
- This product qualifies as a "designated country construction material" per FAR 52.225-11 Buy American-Construction Materials under Trade Agreements effective 04/23/2020.

WARRANTY

- 5 year warranty

KEY DATA	
Lumen Range	5,000–80,000
Wattage Range	36–600
Efficacy Range (LPW)	92–155
Weight lbs. (kg)	13.7-30.9 (6.2-13.9)

VIPER Area/Site

VIPER LUMINAIRE

MICROSTRIKE OPTICS – ORDERING GUIDE

Example: VP-2-320L-145-3K7-2-R-UNV-A3-BLT

CATALOG # _____

VP Series	Optic Platform	Size	Light Engine	CCT/CRI	Distribution	Optic Rotation	Voltage
VP Viper	Micro Strike	1 Size 1	160L-35 ⁶ 5500 lumens 160L-50 ⁶ 7500 lumens 160L-75 10000 lumens 160L-100 12500 lumens 160L-115 15000 lumens 160L-135 18000 lumens 160L-160 21000 lumens	AP AP-Amber Phosphor Converted 27K8 2700K, 80 CRI 3K7 3000K, 70 CRI 3K8 3000K, 80 CRI 35K8 3500K, 80 CRI 3K9 3000K, 90 CRI 4K7 4000K, 70 CRI 4K8 4000K, 80 CRI 4K9 4000K, 90 CRI 5K7 5000K, 70 CRI 5K8 5000K, 80 CRI	2 Type 2 3 Type 3 4F Type 4 Forward 4W Type 4 Wide 5QW Type 5 Square Wide	BLANK No Rotation L Optic rotation left R Optic rotation right	UNV 120-277V 120 120V 208 208V 240 240V 277 277V 347 347V 480 480V
		2 Size 2	320L-145 21000 lumens 320L-170 24000 lumens 320L-185 27000 lumens 320L-210 30000 lumens 320L-235 33000 lumens 320L-255 36000 lumens 320L-315 ⁶ 40000 lumens				
		3 Size 3	480L-285 40000 lumens 480L-320 44000 lumens 480L-340 48000 lumens 480L-390 52000 lumens 480L-425 55000 lumens 480L-470 60000 lumens				
		4 Size 4	720L-435 60000 lumens 720L-475 65000 lumens 720L-515 70000 lumens 720L-565 ⁶ 75000 lumens 720L-600 ⁶ 80000 lumens CLO Custom Lumen Output ¹				

Mounting	
A	Arm mount for square pole/flat surface (B3 Drill Pattern) (Does not include round pole adapter)
A_	Arm mount for round pole ²
ASQU	Universal arm mount for square pole. Can be used with B3 or S2 Drill Pattern
A_U	Universal arm mount for round pole ²
AAU	Adjustable arm for pole mounting (universal drill pattern)
AA_U	Adjustable arm mount for round pole ²
ADU	Decorative upswept Arm (universal drill pattern)
AD_U	Decorative upswept arm mount for round pole ²
MAF	Mast arm fitter for 2-3/8" OD horizontal arm
K	Knuckle
T	Trunnion
WB	Wall Bracket, horizontal tenon with MAF
WM	Wall mount bracket with decorative upswept arm
WA	Wall mount bracket with adjustable arm

Color	
BLT	Black Matte Textured
BLS	Black Gloss Smooth
DBT	Dark Bronze Matte Textured
DBS	Dark Bronze Gloss Smooth
GTT	Graphite Matte Textured
LGS	Light Grey Gloss Smooth
LGT	Light Grey Gloss Textured
PSS	Platinum Silver Smooth
WHT	White Matte Textured
WHS	White Gloss Smooth
VGT	Verde Green Textured
Color Option	
CC	Custom Color

Options	
F	Fusing
2PF	Dual Power Feed
2DR	Dual Driver
TE	Toolless Entry
BC	Backlight Control ⁸
TB	Terminal Block

Network Control Options	
NXWS16F	NX Networked Wireless Enabled Integral NXSP2-LMO PIR Occupancy Sensor with Automatic Dimming Photocell and Bluetooth Programming ^{1,3,4}
NXWS40F	NX Networked Wireless Enabled Integral NXSP2-HMO PIR Occupancy Sensor with Automatic Dimming Photocell and Bluetooth Programming ^{1,3,4}
NXW	NX Networked Wireless Radio Module NXRM2 and Bluetooth Programming, without Sensor ^{3,4}
WIR	wiSCAPE® In-Fixture Module ^{3,4}
WIRSC	wiSCAPE® Module and Occupancy Sensor ^{3,4}
Stand Alone Sensors	
BTS-14F	Bluetooth® Programmable, BTSMP-LMO PIR Occupancy Sensor with Automatic Dimming Photocell and 360° Lens
BTS-40F	Bluetooth® Programmable, BTSMP-HMO PIR Occupancy Sensor with Automatic Dimming Photocell and 360° Lens
BTSO-12F	Bluetooth® Programmable, BTSMP-OMNI-O PIR Occupancy Sensor with Automatic Dimming Photocell and 360° Lens
7PR	7-Pin Receptacle ⁴
7PR-SC	7-Pin Receptacle with shorting cap ⁴
3PR	3-Pin twist lock ⁴
3PR-SC	3-Pin receptacle with shorting cap ⁴
3PR-TL	3-Pin PCR with photocontrol ⁴
Programmed Controls	
ADD	AutoDim Timer Based Dimming ⁴
ADT	AutoDim Time of Day Dimming ⁴
Photocontrols	
PC	Button Photocontrol ^{4,7}

1 – Items with a grey background can be done as a custom order. Contact brand representative for more information

2 – Replace “_” with “2” for 2.5”-3.4” OD pole, “3” for 3.5”-4.13” OD pole, “4” for 4.18”-5.25” OD pole, “5” for 5.5”-6.5” OD pole

3 – Networked Controls cannot be combined with other control options

4 – Not available with 2PF option

5 – Not available with Dual Driver option

6 – Some voltage restrictions may apply when combined with controls

7 – Not available with 480V

8 – BC not available on 4F and type 5 distributions

VIPER Area/Site

VIPER LUMINAIRE

STRIKE OPTIC – ORDERING GUIDE

Example: VP-ST-1-36L-39-3K7-2-UNV-A-BLT

CATALOG # _____

VP	Optic Platform	Size	Light Engine	CCT/CRI	Distribution	Optic Rotation	Voltage
VP Viper	ST Strike	1 Size 1	36L-39 ⁸ 5500 lumens 36L-55 ⁸ 7500 lumens 36L-85 10000 lumens 36L-105 12500 lumens 36L-120 14000 lumens	AM monochromatic amber, 595nm 27K8 2700K, 80 CRI 3K7 3000K, 70 CRI 3K8 3000K, 80 CRI 3K9 3000K, 90 CRI 35K8 3500K, 80 CRI 4K7 4000K, 70 CRI 4K8 4000K, 80 CRI 4K9 4000K, 90 CRI 5K7 5000K, 70 CRI 5K8 5000K, 80 CRI	FR Auto Front Row 2 Type 2 3 Type 3 4F Type 4 Forward 4W Type 4 Wide 5QN Type 5 Square Narrow 5QW Type 5 Square Wide 5QM Type 5 Square Medium 5W Type 5 Wide (Round) 5RW Type 5 Rectangular C Corner Optic TC Tennis Court Optic	BLANK No Rotation L Optic rotation left R Optic rotation right	UNV 120-277V 120 120V 208 208V 240 240V 277 277V 347 347V 480 480V
		2 Size 2	72L-115 15000 lumens 72L-145 18000 lumens 72L-180 21000 lumens 72L-210 24000 lumens 72L-240 27000 lumens				
		3 Size 3	108L-215 ⁸ 27000 lumens 108L-250 30000 lumens 108L-280 33000 lumens 108L-325 36000 lumens 108L-365 40000 lumens				
		4 Size 4	162L-320 40000 lumens 162L-365 ¹⁰ 44000 lumens 162L-405 48000 lumens 162L-445 52000 lumens 162L-485 55000 lumens 162L-545 ⁸ 60000 lumens CLO Custom Lumen Output ¹				

Mounting	Color	Options	Network Control Options
A Arm mount for square pole/flat surface	BLT Black Matte Textured	F Fusing	NXWS16F NX Networked Wireless Enabled Integral NX SMP2-LMO PIR Occupancy Sensor with Automatic Dimming Photocell and Bluetooth Programming ^{1,3,4}
A_ Arm mount for round pole ³	BLS Black Gloss Smooth	E Battery Backup ^{1,2,7,8,9}	NXWS40F NX Networked Wireless Enabled Integral NX SMP2-HMO PIR Occupancy Sensor with Automatic Dimming Photocell and Bluetooth Programming ^{1,3,4}
ASQU Universal arm mount for square pole	DBT Dark Bronze Matte Textured	2PF Dual Power Feed	NXW NX Networked Wireless Radio Module NXRM2 and Bluetooth Programming, without Sensor ^{3,4}
A_U Universal arm mount for round pole ³	DBS Dark Bronze Gloss Smooth	2DR Dual Driver	WIR wiSCAPE® In-Fixture Module ^{3,4}
AAU Adjustable arm for pole mounting (universal drill pattern)	GTT Graphite Matte Textured	TE Tooless Entry	WIRSC wiSCAPE® Module and Occupancy Sensor ^{3,4}
AA_U Adjustable arm mount for round pole ³	LGS Light Grey Gloss Smooth	BC Backlight Control	Stand Alone Sensors
ADU Decorative upswept Arm (universal drill pattern)	LGT Light Grey Gloss Textured	TB Terminal Block	BTS-14F Bluetooth® Programmable, BTSMP-LMO PIR Occupancy Sensor with Automatic Dimming Photocell and 360° Lens
AD_U Decorative upswept arm mount for round pole ³	PSS Platinum Silver Smooth		BTS-40F Bluetooth® Programmable, BTSMP-HMO PIR Occupancy Sensor with Automatic Dimming® Photocell and 360° Lens
MAF Mast arm fitter for 2-3/8" OD horizontal arm	WHT White Matte Textured		BTSO-12F Bluetooth® Programmable, BTSMP-OMNI-O PIR Occupancy Sensor with Automatic Dimming Photocell and 360° Lens
K Knuckle	WHS White Gloss Smooth		7PR 7-Pin Receptacle ⁴
T Trunnion	VGT Verde Green Textured		7PR-SC 7-Pin Receptacle with shorting cap ⁴
WB Wall Bracket, horizontal tenon with MAF	Color Option		3PR 3-Pin twist lock ⁴
WM Wall mount bracket with decorative upswept arm	CC Custom Color		3PR-SC 3-Pin receptacle with shorting cap ⁴
WA Wall mount bracket with adjustable arm			3PR-TL 3-Pin PCR with photocontrol ⁴
			Programmed Controls
			ADD AutoDim Timer Based Dimming ⁴
			ADT AutoDim Time of Day Dimming ⁴
			Photocontrols
			PC Button Photocontrol ^{4,7}

1 – Items with a grey background can be done as a custom order. Contact brand representative for more information

2 – Battery temperature rating -20C to 55C

3 – Replace “_” with “3” for 3.5”-4.13” OD pole, “4” for 4.18”-5.25” OD pole, “5” for 5.5”-6.5” OD pole

4 – Networked Controls cannot be combined with other control options

5 – Not available with 2PF option

6 – Not available with 480V

7 – Not available with 347 or 480V

8 – Not available with Dual Driver option

9 – Only available in Size 1 housing, up to 105 Watts

10 – Some voltage restrictions may apply when combined with controls

VIPER Area/Site

VIPER LUMINAIRE

DELIVERED LUMENS

For delivered lumens, please see Lumens Data PDF on www.Currentlighting.com

PROJECTED LUMEN MAINTENANCE

Ambient Temp.	0	25,000	*TM-21-11 36,000	50,000	100,000	Calculated L ₇₀ (Hours)
25°C / 77°F	1.00	0.97	0.96	0.95	0.91	408,000
40°C / 104°F	0.99	0.96	0.95	0.94	0.89	356,000

LUMINAIRE AMBIENT TEMPERATURE FACTOR (LATF)

Ambient Temperature		Lumen Multiplier
0°C	32°F	1.03
10°C	50°F	1.01
20°C	68°F	1.00
25°C	77°F	1.00
30°C	86°F	0.99
40°C	104°F	0.98

Micro Strike Lumen Multiplier			
CCT	70 CRI	80 CRI	90 CRI
2700K	–	0.841	–
3000K	0.977	0.861	0.647
3500K	–	0.900	–
4000K	1	0.926	0.699
5000K	1	0.937	0.791
Monochromatic Amber Multiplier			
Amber	0.250		

Strike Lumen Multiplier			
CCT	70 CRI	80 CRI	90 CRI
2700K	0.9	0.81	0.62
3000K	0.933	0.853	0.659
3500K	0.959	0.894	0.711
4000K	1	0.9	0.732
5000K	1	0.9	0.732
Monochromatic Amber Multiplier			
Amber	0.255		

VIPER Area/Site

VIPER LUMINAIRE

DATE:	LOCATION:
TYPE:	PROJECT:
CATALOG #:	

ELECTRICAL DATA: MICRO STRIKE

# OF LEDS	160						
NOMINAL WATTAGE	35	50	75	100	115	135	160
SYSTEM POWER (W)	34.9	50.5	72.1	97.2	111.9	132.2	157.8
INPUT VOLTAGE (V)	CURRENT (Amps)						
120	0.29	0.42	0.63	0.83	0.96	1.13	1.33
208	0.17	0.24	0.36	0.48	0.55	0.65	0.77
240	0.15	0.21	0.31	0.42	0.48	0.56	0.67
277	0.13	0.18	0.27	0.36	0.42	0.49	0.58
347	0.10	0.14	0.22	0.29	0.33	0.39	0.46
480	0.07	0.10	0.16	0.21	0.24	0.28	0.33

# OF LEDS	320						
NOMINAL WATTAGE	145	170	185	210	235	255	315
SYSTEM POWER (W)	150	166.8	185.7	216.2	240.9	261.5	312
INPUT VOLTAGE (V)	CURRENT (Amps)						
120	1.21	1.42	1.54	1.75	1.96	2.13	2.63
208	0.70	0.82	0.89	1.01	1.13	1.23	1.51
240	0.60	0.71	0.77	0.88	0.98	1.06	1.31
277	0.52	0.61	0.67	0.76	0.85	0.92	1.14
347	0.42	0.49	0.53	0.61	0.68	0.73	0.91
480	0.30	0.35	0.39	0.44	0.49	0.53	0.66

# OF LEDS	480					
NOMINAL WATTAGE	285	320	340	390	425	470
SYSTEM POWER (W)	286.2	316.7	338.4	392.2	423.2	468
INPUT VOLTAGE (V)	CURRENT (Amps)					
120	2.38	2.67	2.83	3.25	3.54	3.92
208	1.37	1.54	1.63	1.88	2.04	2.26
240	1.19	1.33	1.42	1.63	1.77	1.96
277	1.03	1.16	1.23	1.41	1.53	1.70
347	0.82	0.92	0.98	1.12	1.22	1.35
480	0.59	0.67	0.71	0.81	0.89	0.98

# OF LEDS	720				
NOMINAL WATTAGE	435	475	515	565	600
SYSTEM POWER (W)	429.3	475	519.1	565.2	599.9
INPUT VOLTAGE (V)	CURRENT (Amps)				
120	3.63	3.96	4.29	4.71	5.00
208	2.09	2.28	2.48	2.72	2.88
240	1.81	1.98	2.15	2.35	2.50
277	1.57	1.71	1.86	2.04	2.17
347	1.25	1.37	1.48	1.63	1.73
480	0.91	0.99	1.07	1.18	1.25

VIPER Area/Site

VIPER LUMINAIRE

ELECTRICAL DATA: STRIKE

# OF LEDS	36				
NOMINAL WATTAGE	39	55	85	105	120
SYSTEM POWER (W)	39.6	56.8	83.6	108.2	120.9
INPUT VOLTAGE (V)	CURRENT (Amps)				
120	0.33	0.46	0.71	0.88	0.96
208	0.19	0.26	0.41	0.50	0.55
240	0.16	0.23	0.35	0.44	0.48
277	0.14	0.20	0.31	0.38	0.42
347	0.11	0.16	0.24	0.30	0.33
480	0.08	0.11	0.18	0.22	0.24

# OF LEDS	72				
NOMINAL WATTAGE	115	145	180	210	240
SYSTEM POWER (W)	113.7	143.2	179.4	210.2	241.7
INPUT VOLTAGE (V)	CURRENT (Amps)				
120	1.00	1.21	1.50	1.75	1.79
208	0.58	0.70	0.87	1.01	1.03
240	0.50	0.60	0.75	0.88	0.90
277	0.43	0.52	0.65	0.76	0.78
347	0.35	0.42	0.52	0.61	0.62
480	0.25	0.30	0.38	0.44	0.45

# OF LEDS	108				
NOMINAL WATTAGE	215	250	280	325	365
SYSTEM POWER (W)	214.8	250.8	278.3	324.7	362.6
INPUT VOLTAGE (V)	CURRENT (Amps)				
120	2.00	2.08	2.33	3.04	2.67
208	1.15	1.20	1.35	1.75	1.54
240	1.00	1.04	1.17	1.52	1.33
277	0.87	0.90	1.01	1.32	1.16
347	0.69	0.72	0.81	1.05	0.92
480	0.50	0.52	0.58	0.76	0.67

# OF LEDS	162					
NOMINAL WATTAGE	320	365	405	445	485	545
SYSTEM POWER (W)	322.1	362.6	403.6	445.1	487.1	543.9
INPUT VOLTAGE (V)	CURRENT (Amps)					
120	2.71	2.67	3.38	3.71	4.04	4.54
208	1.56	1.54	1.95	2.14	2.33	2.62
240	1.35	1.33	1.69	1.85	2.02	2.27
277	1.17	1.16	1.46	1.61	1.75	1.97
347	0.94	0.92	1.17	1.28	1.40	1.57
480	0.68	0.67	0.84	0.93	1.01	1.14

VIPER Area/Site

VIPER LUMINAIRE

MICRO STRIKE PHOTOMETRY

The following diagrams represent the general distribution options offered for this product. For detailed information on specific product configurations, see website photometric test reports.

Type 2

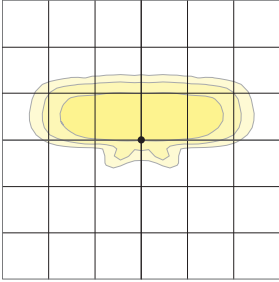

Type 3

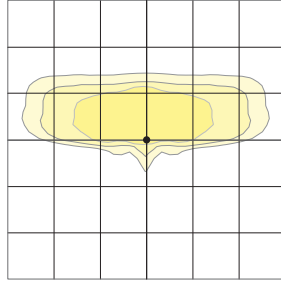

Type 4 Wide

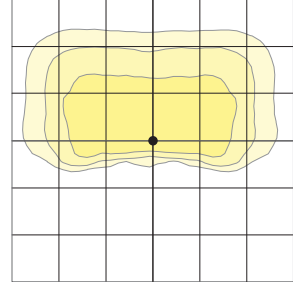

Type 4F

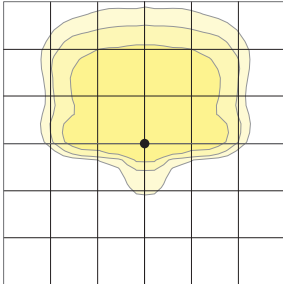

Type 5QW

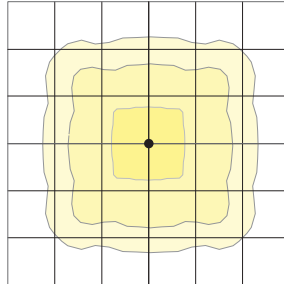

VIPER Area/Site

VIPER LUMINAIRE

OPTIC STRIKE PHOTOMETRY

The following diagrams represent the general distribution options offered for this product. For detailed information on specific product configurations, see website photometric test reports.

Type FR – Front Row/Auto Optic

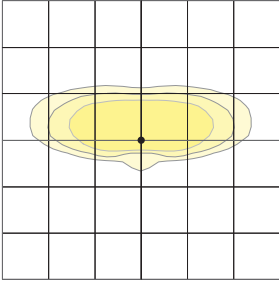

Type 2

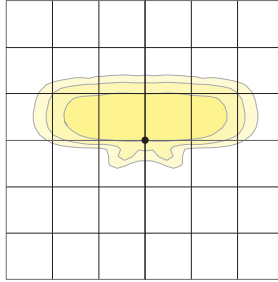

Type 3

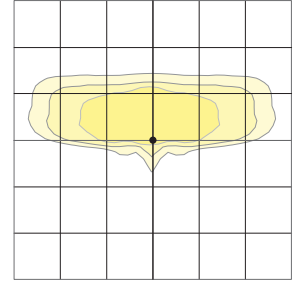

Type 4 Forward

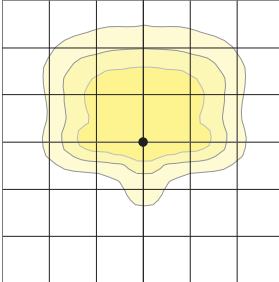

Type 4 Wide

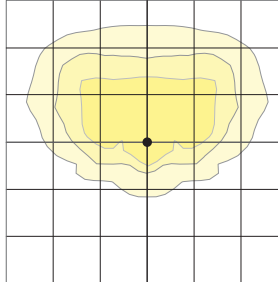

Type 5QM

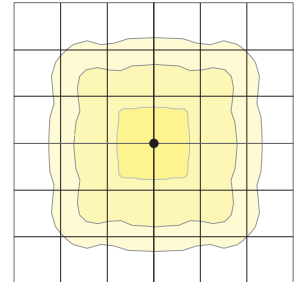

Type 5R (rectangular)

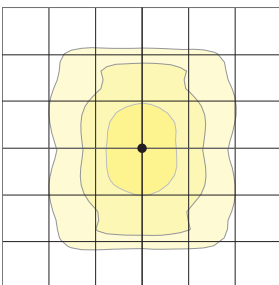

Type 5W (round wide)

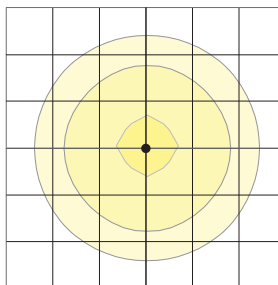

Type TC

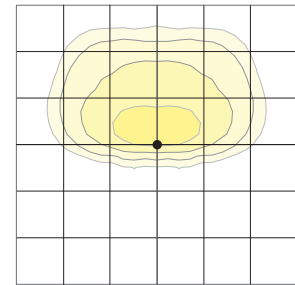

Type Corner

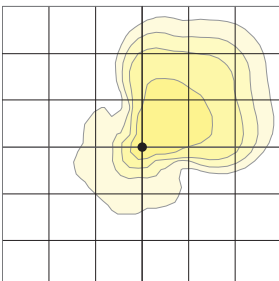

VIPER Area/Site

VIPER LUMINAIRE

DIMENSIONS

SIZE 1

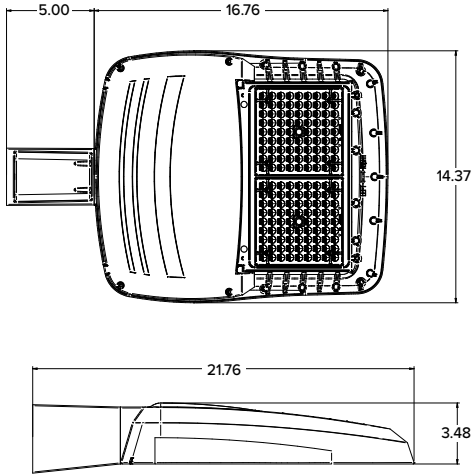

SIZE 2

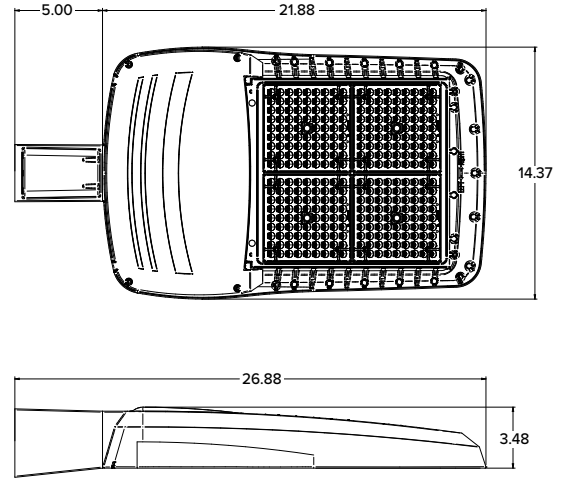



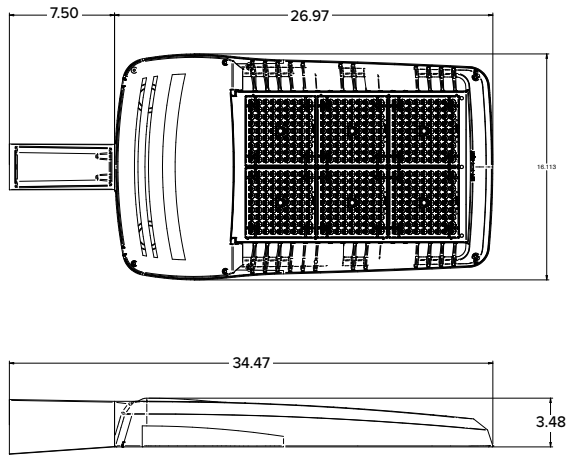

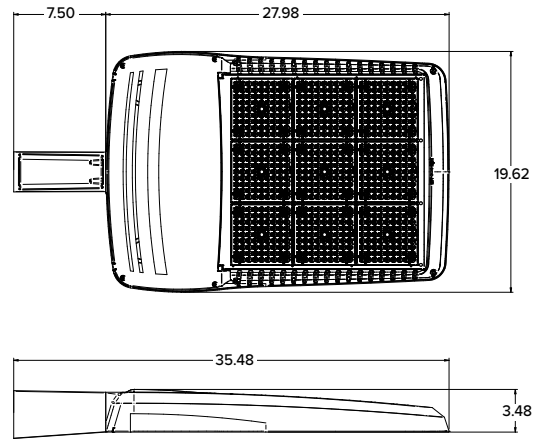

SIZE 3



SIZE 4



	EPA				Config.
	VP1 (Size 1)	VP2 (Size 2)	VP3 (Size 3)	VP4 (Size 4)	
Single Fixture	0.454	0.555	0.655	0.698	
Two at 180	0.908	1.110	1.310	1.396	
Two at 90	0.583	0.711	0.857	0.948	
Three at 90	1.037	1.266	1.512	1.646	
Three at 120	0.943	1.155	1.392	1.680	
Four at 90	1.166	1.422	1.714	1.896	

	Weight	
	lbs	kgs
VP1 (Size 1)	13.7	6.2
VP2 (Size 2)	16.0	7.26
VP3 (Size 3)	25.9	11.7
VP4 (Size 4)	30.8	13.9

VIPER Area/Site

VIPER LUMINAIRE

MOUNTING



A-STRAIGHT ARM MOUNT

Fixture ships with integral arm for ease of installation. Compatible with Current Outdoor B3 drill pattern for ease of installation on square poles. For round poles add applicable suffix (2/3/4/5)

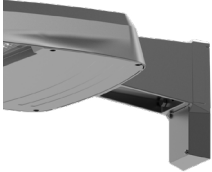
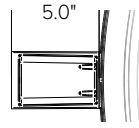

ASQU-UNIVERSAL ARM MOUNT

Universal mounting block for ease of installation. Compatible with drill patterns from 2.5" to 4.5" and Current drill pattern S2. For round poles add applicable suffix (2/3/4/5)

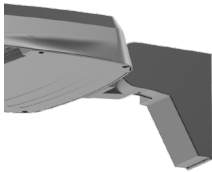
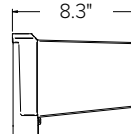

AAU-ADJUSTABLE ARM FOR POLE MOUNTING

Rotatable arm mounts directly to pole. Compatible with drill patterns from 2.5" to 4.5" and Current drill pattern S2 and B3. For round poles add applicable suffix (2/3/4/5). Rotatable in 15° aiming angle increments. Micro Strike configurations have a 45° aiming limitation.

Strike configurations have a 30° aiming limitation.

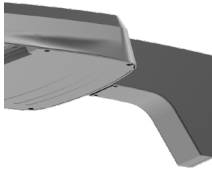
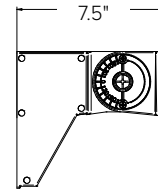

ADU-DECORATIVE UPSWEPT ARM

Upswept Arm compatible with drill patterns from 2.5" to 4.5" and Current drill pattern S2. For round poles add applicable suffix (2/3/4/5).

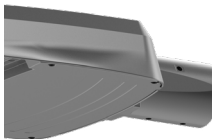
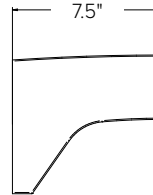

MAF-MAST ARM FITTER

Fits 2-3/8" OD horizontal tenons.

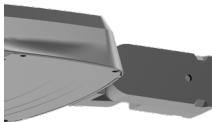
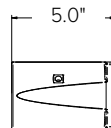

K-KNUCKLE

Knuckle mount 15° aiming angle increments for precise aiming and control, fits 2-3/8" tenons or pipes. Micro Strike configurations have a 45° aiming limitation. Strike configurations have a 30° aiming limitation.

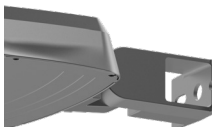
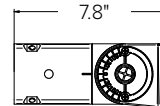

T-TRUNNION

Trunnion for surface and crossarm mounting using (1) 3/4" or (2) 1/2" size through bolts. Micro Strike configurations have a 45° aiming limitation. Strike configurations have a 30° aiming limitation.

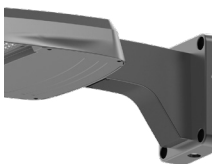
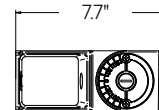

WM-WALL MOUNT

Compatible with universal arm mount, adjustable arm mount, and decorative arm mount. The WA option uses the same wall bracket but replaces the decorative arm with an adjustable arm.

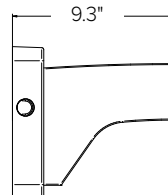

VIPER Area/Site

VIPER LUMINAIRE

ADDITIONAL INFORMATION (CONTINUED)

HOUSE SIDE SHIELD FIELD INSTALL ACCESSORIES

HSS has a depth of 5" for all Viper sizes

Not to be used with Occupancy Sensors as the shield may block the light to the sensor.

VPR2x HSS-90-B-xx

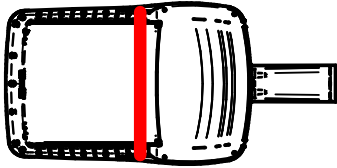

VPR2x HSS-270-BSS-xx

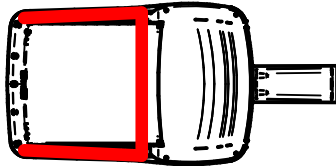

VPR2x HSS-360-xx

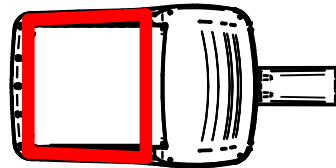

VPR2x HSS-90-F-xx

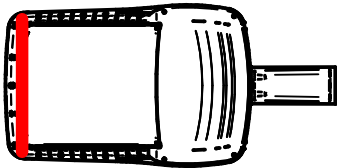

VPR2x HSS-270-FSS-xx

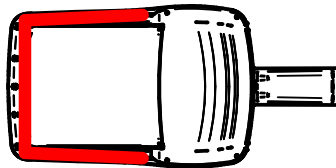

VPR2x HSS-90-S-xx

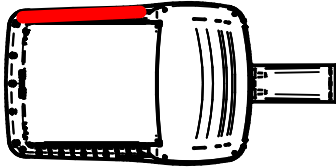

VPR2x HSS-270-FSB-xx

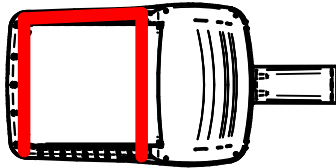

VPR2x HSS-90-S-xx

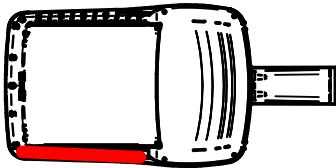

VPR2x HSS-270-FSB-xx

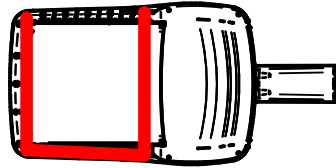

VIPER Area/Site

VIPER LUMINAIRE

ADDITIONAL INFORMATION (CONTINUED)

PROGRAMMED CONTROLS

ADD-AutoDim Timer Based Options

- Light delay options from 1-9 hours after the light is turned on to dim the light by 10-100%. To return the luminaire to its original light level there are dim return options from 1-9 hours after the light has been dimmed previously.

EX: ADD-6-5-R6

ADD Control Options	Configurations Choices	Example Choice Picked
Auto-Dim Options	1-9 Hours	6 - Delay 6 hours
Auto-Dim Brightness	10-100% Brightness	5 - Dim to 50% brightness
Auto-Dim Return	Delay 0-9 Hours	R6 - Return to full output after 6 hours

ADT-AutoDim Time of Day Based Option

- Light delay options from 1AM-9PM after the light is turned on to dim the light by 10-100%. To return the luminaire to its original light level there are dim return options from 1AM-9PM after the light has been dimmed previously.

EX: ADT-6-5-R6

ADD Control Options	Configurations Choices	Example Choice Picked
Auto-Dim Options	12-3 AM and 6-11 PM	6 - Dim at 6PM
Auto-Dim Brightness	10-100% Brightness	5 - Dim to 50%
Auto-Dim Return	12-6 AM and 9-11P	R6 - Return to full output at 6AM