

1345 Baseline Road

Architectural Design Report

UDRP

2026-03-06



rla / architecture



FOTENN
Planning + Design

PROJECT INTRODUCTION



The proposed development consists of 4 high-rise rental apartment towers situated at the four corners of the subject property. Each tower has been designed to conform to the City's high-rise guidelines, with ample separation between the towers and clear distinctions between podium, tower, and crown. The proposed towers range in height from 28 to 40 storeys, and all feature 4 storey podiums with active commercial or residential amenity uses at grade. A major focus of the site is the centralized municipal park, this park is approximately 9% of the total site area with an additional POPS area provided that acts as a plaza for residents and brings green space further into the site. The municipal park fronts onto Baseline Road providing easy access to the broader community, and is situated equal distance between to the two high-rise towers with ample southern exposure.

Access to the site is off the existing shared right-of-way to the west, beside the existing retail plaza. A private road has been added to the site to provide vehicular access to all 4 buildings, with the primary access to the site located in the middle of the western property line. The road continues east from the entrance, where the main lobbies of towers A and B are located, along with the entrance to their shared underground parking, the road passes the park and then turns north and connects to the road that runs along the northern property line. This road on the north of the site connects to the existing right-of-way and provides access to the shared underground parking for buildings C and D, and could potentially connect to sites further to the East, if the opportunity arises.

All of the required parking is located below grade, with additional on grade parking spots for short term parking, drop off/pick-up, loading, and maintenance vehicles. At this time, we are assuming a parking ratio of .7 per unit as this site is very well served by public transit, and has access to services located nearby.

As the design process progressed, we amended the tower plate from the original slab design to a point tower. The change allowed us to maximize the tower separations, provide more public space, and created an overall more efficient and desirable layout for the interior units.

It should be noted the proposed development is intended to be constructed in phases. Phase 1 will proceed with tower A, with towers C and D following after that, while tower B will be held in reserve until the site has adequate access to municipal services that can accommodate the full number of occupants. When built out the site could contain 1,200 residential units within a total of 960,000sqft.

DESIGN POLICY RESPONSE

Sustainable Design and Height Transition

- / The proposal intends to incorporate the latest in building design, durable materials, and sustainable technologies consistent with the intent of the High-Performance Development Standard, supporting climate resilience along the Corridor.
- / The site's location on an Arterial Road within the Mainstreet Corridor designation supports high-rise development. Building heights and massing are arranged to minimize impacts on adjacent low-rise neighbourhoods through setbacks, stepbacks, and a graduated transition in scale.
- / A 45-degree angular plane is used as a guiding tool to achieve an appropriate transition from the tallest elements along Baseline Road toward the adjacent neighbourhood. *(OP Policies 4.6.4.1, 11.1, 4.6.5.1, 4.6.6.2; High-Rise Guidelines 1.12, 1.14, 1.16)*

Public Realm, Pedestrian Experience, and Servicing

- / The proposal replaces a surface parking-dominated parcel with a continuous, animated street edge defined by a podium scaled to the pedestrian realm, active at-grade uses, frequent entrances, and ample glazing.
- / Sidewalk improvements, landscaping, and a new public park improve pedestrian comfort and neighbourhood amenities while strengthening the streetwall condition along Baseline Road, the new public road, and the internal drive aisle.
- / Loading, servicing, and mechanical functions are internalized within the building and accessed from an internal drive aisle located away from the arterial roadway, reducing conflicts and minimizing interruptions to the public realm. *(OP Policies 4.6.5.2, 4.6.5.3; High-Rise Guideline 2.1)*

Built Form, Permeability, and Microclimate

- / The proposed buildings are designed with a clear base-middle-top expression, frame the street and park edges, and include mid-block pedestrian connections for site permeability.
- / The high-rise towers are designed with articulated façades and stepbacks that reinforce the podium as the primary street-defining element and contribute positively to both Baseline Road's pedestrian realm and skyline.
- / Setbacks and landscaped areas support tree planting, while stepbacks reduce canyon effects and mitigate microclimatic impacts on sidewalks and amenity areas. *(OP Policies 4.6.6.7, 4.6.6.8; High-Rise Guidelines 2.3, 2.29, 2.31)*

Amenity Areas

- / A range of indoor and outdoor amenity spaces will be provided, including at-grade landscaped areas, indoor communal rooms, and rooftop amenity terraces, designed to accommodate users of all ages and throughout all seasons. *(OP Policy 4.6.6.4)*

Tower Floorplates, Separation, Privacy, and Shadow Impacts

- / The proposed residential tower floorplates, approximately 786.7 m², slightly exceed the 750 m² guideline. However, this modest increase is justified by the site's Corridor context, large lot size, generous setbacks, tower separation distances, and the slender, articulated tower design.
- / Tower separation, orientation, and setbacks meet or exceed applicable guidelines and provide adequate light, sky views, and privacy between towers on this site and towards surrounding properties.
- / Tower orientation, narrow floorplates, and stepbacks minimize shadow duration, reduce wind impacts, and maintain usable outdoor spaces. Shadows move quickly and are consistent with expectations for point-tower development along an Arterial corridor. *(OP Policies 4.6.6.8, 4.6.6.9; High-Rise Guidelines 2.24(c), 2.25)*

Overall, the proposed development demonstrates strong conformity with the City's Official Plan design policies and the Urban Design Guidelines for High-Rise Buildings. Where minor deviations occur, they are supported by contextual analysis and technical studies and continue to meet the underlying intent of the applicable policies.

DESIGN POLICY RESPONSE

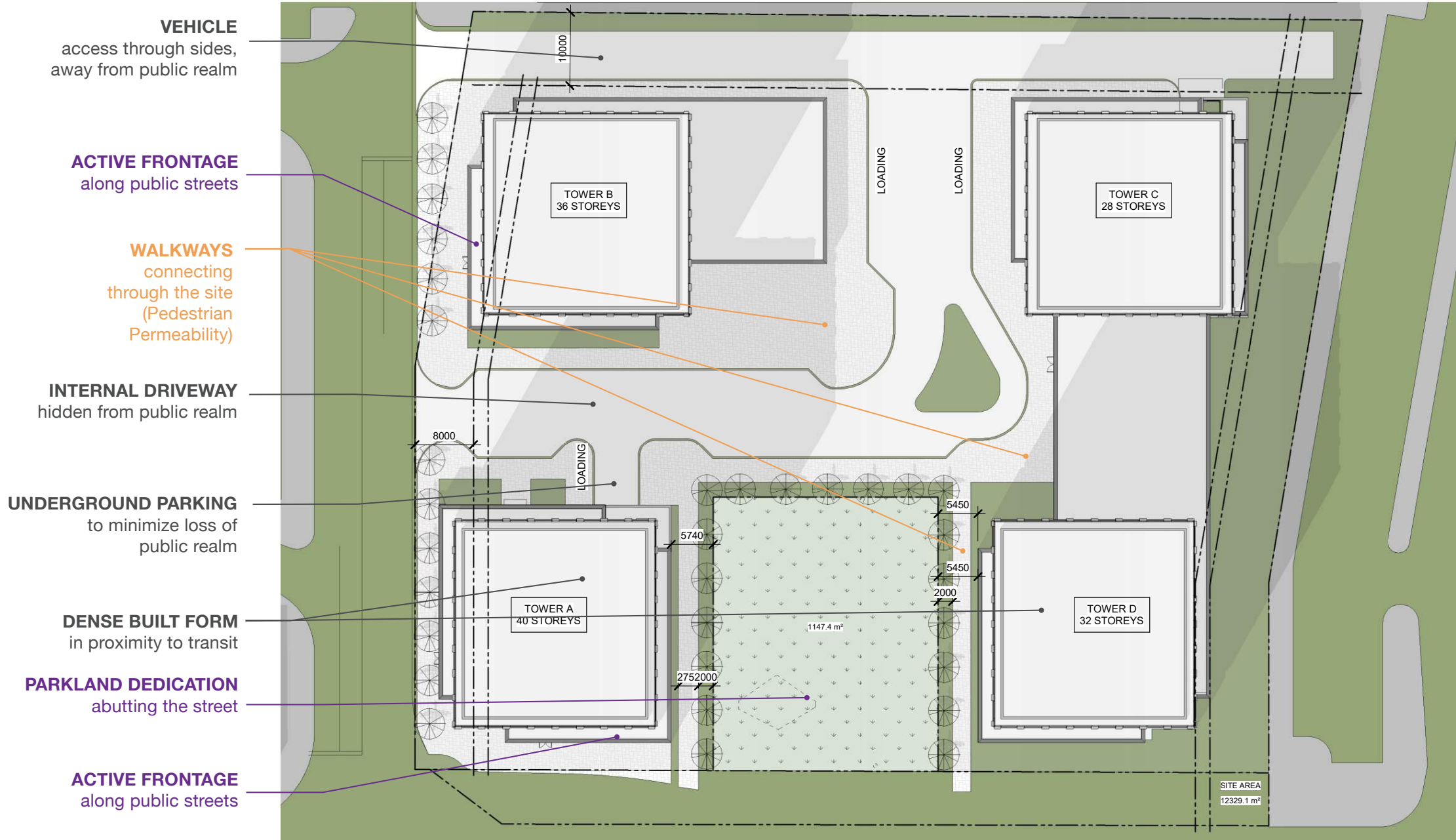

DESIGN POLICY RESPONSE



TOWER MATERIALITY
lighter materials and glazing
within the tower to
compliment the skyline

PODIUM MATERIALITY
enhances the streetscape
through a vibrant red
brick materiality

GLAZING
enhances the public realm and
reinforces the streetscape through
transparent facades along the
ground floor

TOWER HEIGHT
are reduced at the rear to
respect adjacent residential
neighbourhoods

PODIUM HEIGHT
engages the public realm and
interacts with the human scale

TOWER ARTICULATION
frames the public realm and
enhances the architecture through
a continuous glazing facade at the
corner

PRE-APPLICATION CONSULTATION COMMENTS

A Pre-Application Consultation Meeting was held on June 25, 2025. As a result of this meeting, the following comments were received from the Urban Design team at the City of Ottawa. Responses to these comments are also provided below.

1345 Baseline Road, Ottawa
Response to Comments - Pre-Consultation Meeting Feedback
Zoning By-Law Amendment Application (PC2025-0177)

No.	Comment	Response
1.0	Urban Design	
	General	
17	An Urban Design Brief is required. Please see attached customized Terms of Reference to guide the preparation. a. The Urban Design Brief should be structured by generally following the headings highlighted under Section 3 – Contents of these Terms of Reference	Acknowledged. The Urban Design Brief TOR have been consulted and used as the basis for this UDRP submission.
18	The site is located within a Design Priority Area, as such, a visit to the UDRP, and a UDRP Report is required as part of a complete submission.	Acknowledged. We will attend the UDRP and provide a presentation. A corresponding UDRP report is also being prepared.
19	Additional drawings and studies are required as shown on the SPIL. Please follow the terms of references (Planning application submission information and materials City of Ottawa) to prepare these drawings and studies. These include: a. Site Plan. b. Landscape Plan c. Building Elevations d. Conceptual Floorplans	The required plans and studies listed have been prepared and are included as part of this submission.
20	The City is in the process of preparing a Secondary Plan which will ensure that the area develops as one large cohesive community with shared roads and amenities, including parks and community services and facilities.	Acknowledged. The applicant team is aware of the Secondary Plan and will remain informed as the process evolves. Appropriate regard will be given to the Secondary Plan throughout.
21	If the development proceeds in advance of the Secondary Planning process, the site will need to be designed in a manner that supports broader connections into the larger community.	Acknowledged. The site is being design to support connections into the community, as showcased by the public road, internal circulation network, and site pedestrian permeability.
22	UD Staff think that there should be at least one public road preferably east-west that provides connections into the broader community with the potential for future expansion as the area continues to intensify:	A public road, as shown in the image below, has been incorporated into the site design.
		

PRE-APPLICATION CONSULTATION COMMENTS

A Pre-Application Consultation Meeting was held on June 25, 2025. As a result of this meeting, the following comments were received from the Urban Design team at the City of Ottawa. Responses to these comments are also provided below.

No.	Comment	Response
23	Please provide a land use strategy for the site. UD Staff recommend a mix of non-res and residential uses to promote live, work, and play in the same district.	A land use strategy is provided and includes a mix of uses on the site.
24	The Baseline Road frontage should include non-res at-grade facing the street.	Tower A which fronts onto Baseline Road, incorporates street-oriented commercial uses that help activate the public realm. Tower D, also fronting Baseline Road, is planned as a retirement residence, and the design and programming of Tower D are intended to support the needs of future residents.
25	Active ground floors will be required for all buildings facing public roads and critical frontages:	Towers A and B incorporate at-grade commercial uses and active frontages along the public roads. Towers C and D also provide an active, publicly accessible entrances, however, commercial uses are not proposed in these buildings, as they are planned to function as retirement residences. Their design and programming prioritize resident needs and supportive services rather than commercial activity.
		
26	UD staff support the development of a mix of mid and high-rise building typologies on the site. Tall buildings need to have regard for the City's built form policies as well as the Urban Design Guidelines for High-Rise Buildings.	Acknowledged. The proposed high-rise buildings have regard for City's built form policies as well as the Urban Design Guidelines for High-Rise Buildings.
27	The tallest building should be closest to the proposed bus rapid transit station with building heights tapering down across the property.	This has been implemented. The tallest building heights are proposed in the western half of the site closest to the rapid transit station, with the tallest building fronting onto Baseline Road.
28	Podiums should not exceed 6 storeys.	The podiums are 4 and 6 storeys.
29	Explore the potential for distinct architecture for the tallest building within the district.	Acknowledged. Further architectural definition will be explored as the design evolves.
30	Please provide a phasing plan for the development of the site and explore the potential for interim uses so significant portions of the site are not vacant and underutilized while the site is being developed in phases.	The western half of the site is the first phase of development and the eastern half of the site is the later phase of development.
31	Parking access and loading should occur internal to the site, similar the old scheme:	Although the new configuration differs from the previous scheme, the parking and loading access remains internal to the site. The revised approach is considered an improvement, as it reduces the number of access and loading points, streamlining circulation and simplifying the overall design. It consolidates elements such as ramps and loading docks, which minimizes potential conflict points, improves efficiency, and provides a more coordinated servicing strategy across the site.

PRE-APPLICATION CONSULTATION COMMENTS

A Pre-Application Consultation Meeting was held on June 25, 2025. As a result of this meeting, the following comments were received from the Urban Design team at the City of Ottawa. Responses to these comments are also provided below.

No.	Comment	Response
		
32	Positioning of the park should consider shadow and microclimate conditions.	The proposed park is uniform and regular in shape, with frontage along both Baseline Road and the internal public street, making it visible and accessible for the public. Its location at the southern edge of the site provides a significant shadow benefit. The proposed buildings do not cast direct shadows into the park. Additionally, any future development to the south would be separated from the park by a right of way approximately 37.5 metres wide, further limiting potential shadow impacts and helping maintain high-quality sunlight access throughout the day.
33	The site should be developed in an urban manner with limited surface parking. Above-grade surface parking spaces should be on-street parking spaces along future public and private roads.	The surface parking has been revised and no longer includes perpendicular parking, rather, proposes only limited parallel street parking, improving the pedestrian realm.
34	Generous public realm (building face to sidewalk curb needed).	Acknowledged, this has been addressed in the design.
35	Tree growth within the public and private realm needed.	Acknowledged, tree planting in the public realm is proposed.
36	Sustainability strategy needed.	Acknowledged, sustainability measures will continue to be refined as the planning and design processes evolve.

REGIONAL CONTEXT



Perspective from Google Earth

Regional Context

The surrounding context is characterized by a mix of land uses, including residential, institutional, and commercial properties with the nearby Central Experimental Farm and Canada Agriculture and Food Museum as a focal point of the area. The neighbourhood surrounding the subject site includes a range of building heights including low-rise, mid-rise and high-rise buildings.

North of the subject site surface is surface parking associated with the commercial use building to the east. To the north is a residential neighbourhood generally, characterized by low-rise detached dwellings with high-rise buildings. Further north are large community amenities, including Carlington Park and Carlington Recreation Centre, and Highway 417 which can be accessed from Maitland Avenue.

East of the subject site are commercial use buildings with a range of building heights, including low-rise and mid-rise buildings. Further east is the Central Experimental Farm.

South of the subject site is a commercial plaza, accommodating several buildings fronting Baseline Road and Merivale Road. Further south is the Fisher Heights residential neighbourhood, generally characterized by low-rise detached dwellings, with townhomes and mid-rise residential buildings.

West of the subject site is a commercial plaza accommodating low-rise buildings fronting onto Baseline Road, a big box store on the interior of the property, and a mid-rise building fronting onto Clyde. West of Clyde Avenue is the Braemar Park – Bel Air Heights – Copeland Park a generally low-rise residential neighbourhood with a concentration of high-rise buildings at the intersection of Baseline Road and Clyde Avenue.

SITE PERSPECTIVE VIEWS

Aerial Views

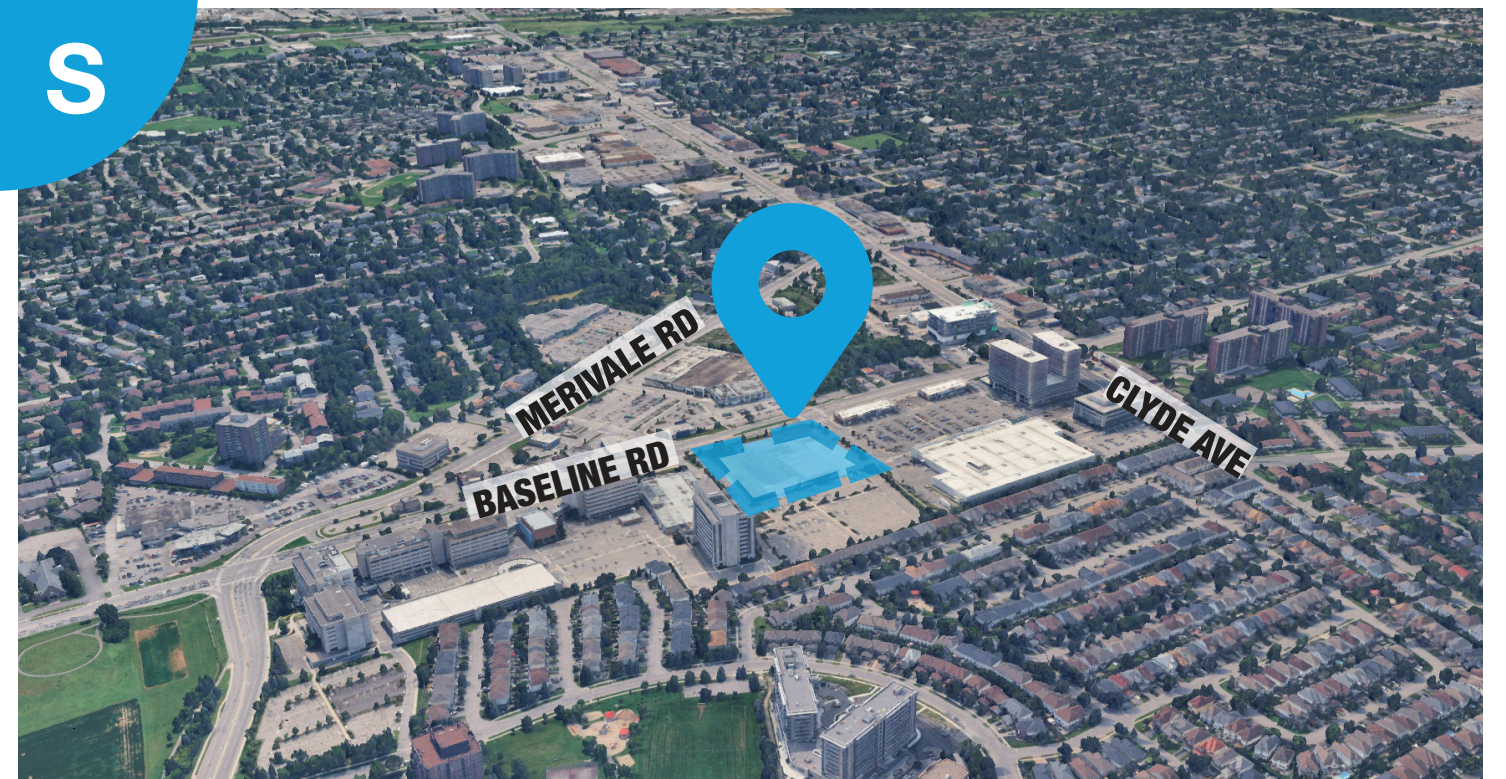
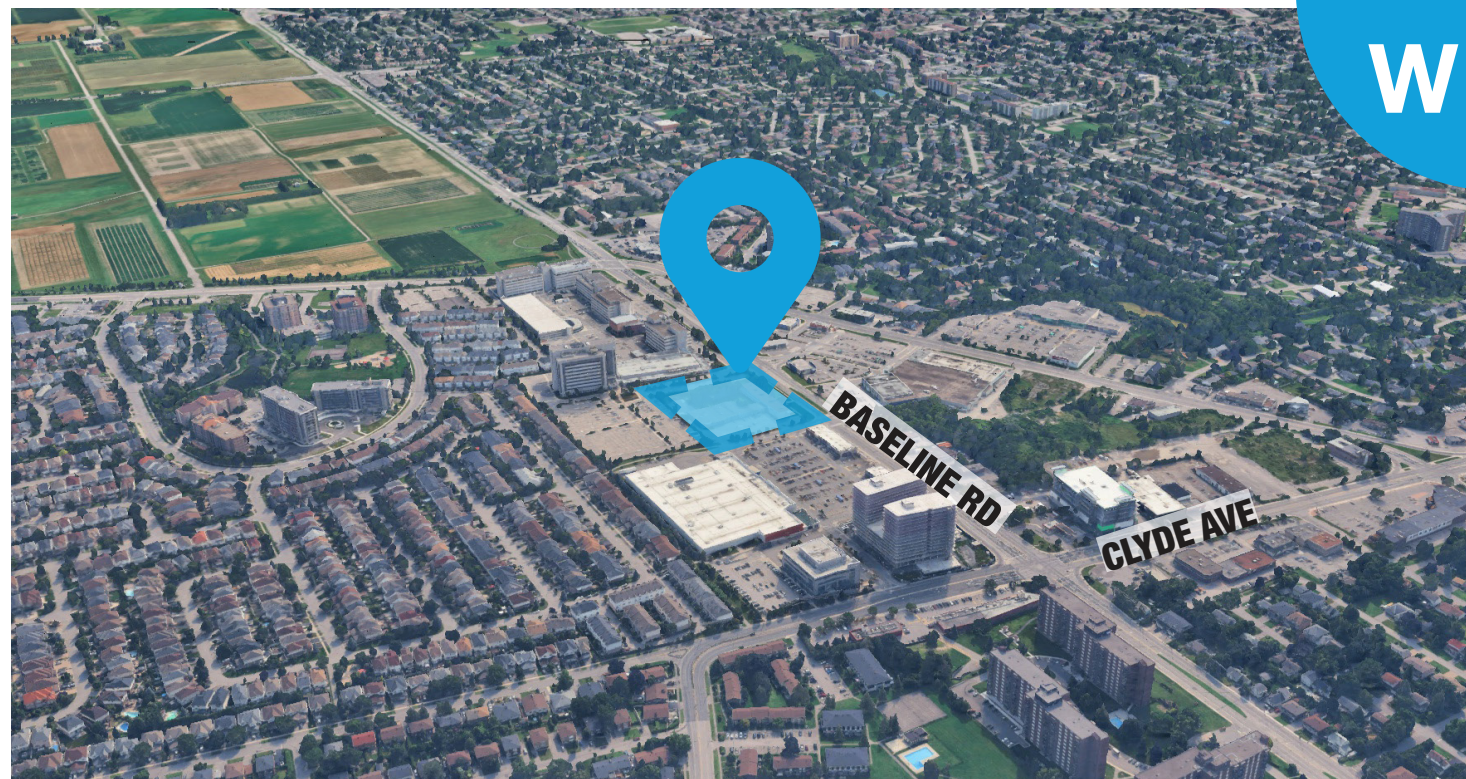

SITE PHOTOS

Street Views

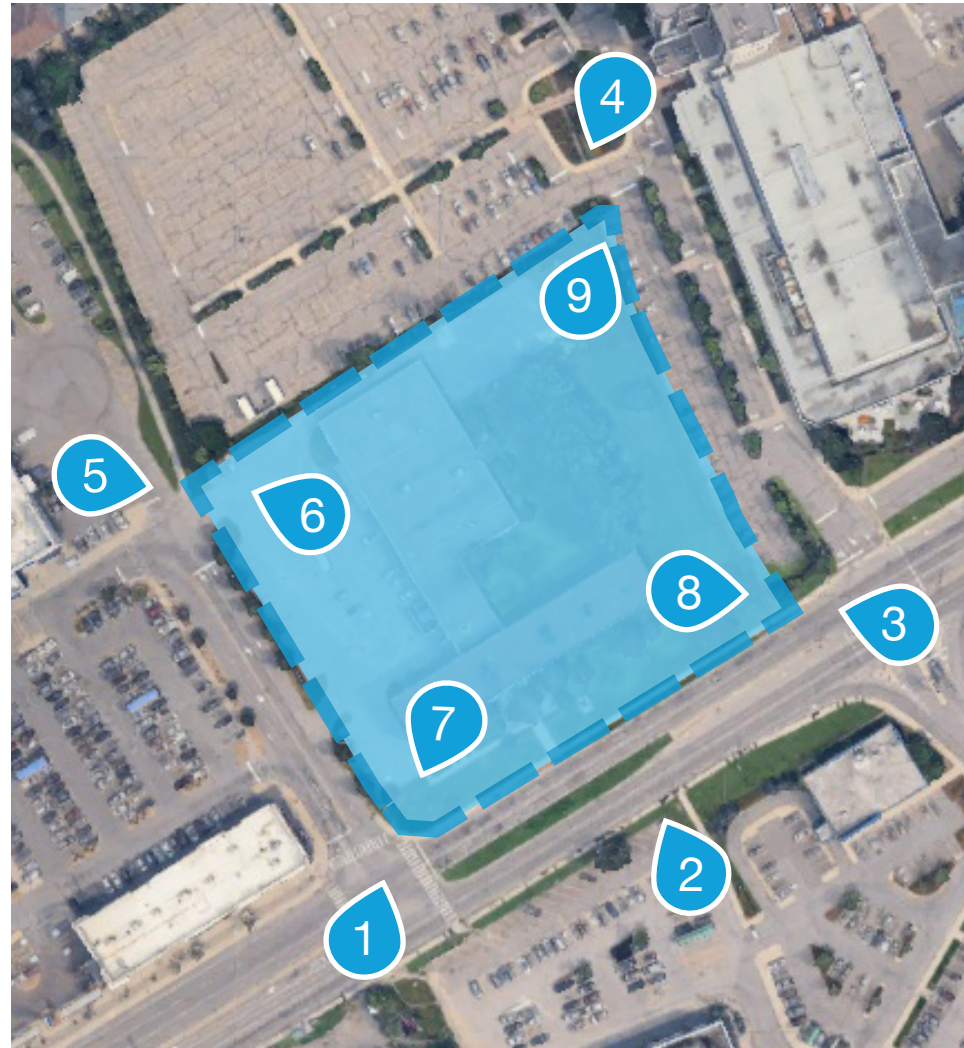

Key Plan indicating location for photos. Aerial image source: Google Earth.



Subject Site

The subject site, municipally known as 1345 Baseline Rd is located in Ward 16 (River) in the Carlington community of the City of Ottawa. The subject site is a square-shaped lot with a total area of approximately 13,156 square metres (3.25 acres), with approximately 109 metres of frontage on Baseline Road.

The subject site currently accommodates a two-storey office use building with associated parking on the west and green open space on the east on the building. The building is arranged in a T-shape with two-storeys parallel to Baseline Road and a one-storey extension to the north. Scouts Canada Quebec Council previously occupied the two buildings, but operations on the subject site have since ceased. The subject site also features a totem pole with cultural heritage value, fronting Baseline Road.

SITE ANALYSIS

Microclimate

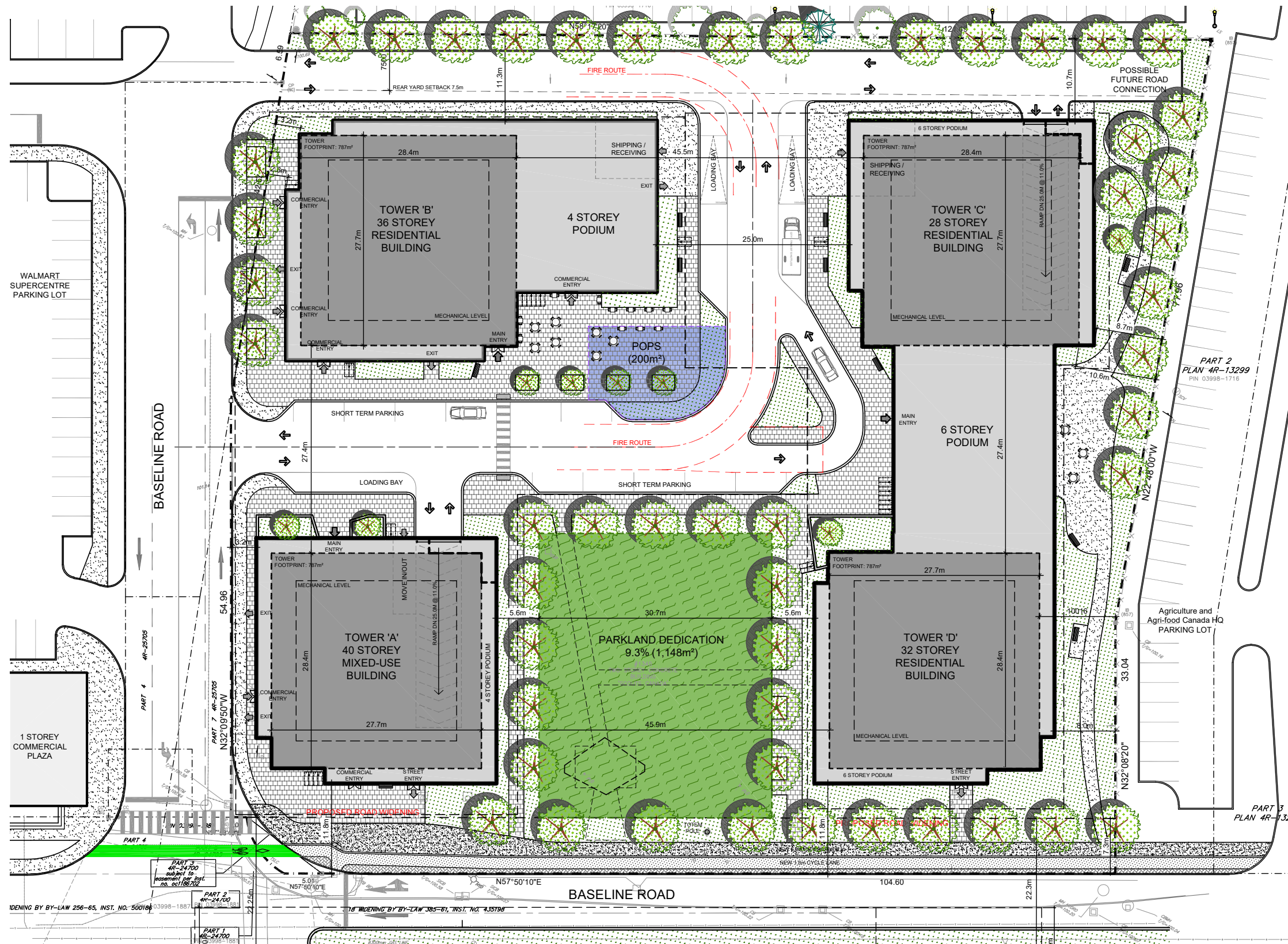

The development incorporates microclimate responsive design strategies, including reduced asphalt coverage, permeable unit pavers, and drainage measures to mitigate heat island effects and manage stormwater.

The proposed tree plantings, landscape buffers and soft landscaping will help to minimize microclimate impacts on the public realm and proposed city park.

The amount of land permitted to asphalt has been reduced to mitigate the negative effects of impervious surfaces. There are permeable pavers such as unit pavers within the walkable surfaces for pedestrians, improving drainage and moisture circulation.

A continuous tree planting strategy along the northeast pathway, complemented by soft landscaping will enhance pedestrian comfort and improve the usability of outdoor amenity spaces. There will also be movable planters along the permeable walkways that introduce additional greenery and microclimatic flexibility along pedestrian routes.

The public realm of this development includes a POPS adjacent to Tower B. The POPS will include a shaded patio area with pergolas and furnishings for residents.

SITE ANALYSIS

Key Destinations









Local Neighbourhood Amenities

The subject site is situated next to Laurentian Place which contains a Walmart, various fast-food establishments and other services. The surrounding areas contain various grocery stores, coffee shops, banks, automobile-related services and fitness centres.

There are open spaces accessible within a 500m radius of the project site. Some of these being Celebration Park, the Experimental Farm, Trillium Park and Gilbey Park. The parks are currently used by the residents of the surrounding neighbourhoods.

Legend

-  Food/Beverage Services
-  Fitness Centres
-  Retail/Grocery Stores
-  Services
-  Worship
-  Open Spaces

Local Amenities Map - Background Image from Google Maps

SITE ANALYSIS

Urban Pattern

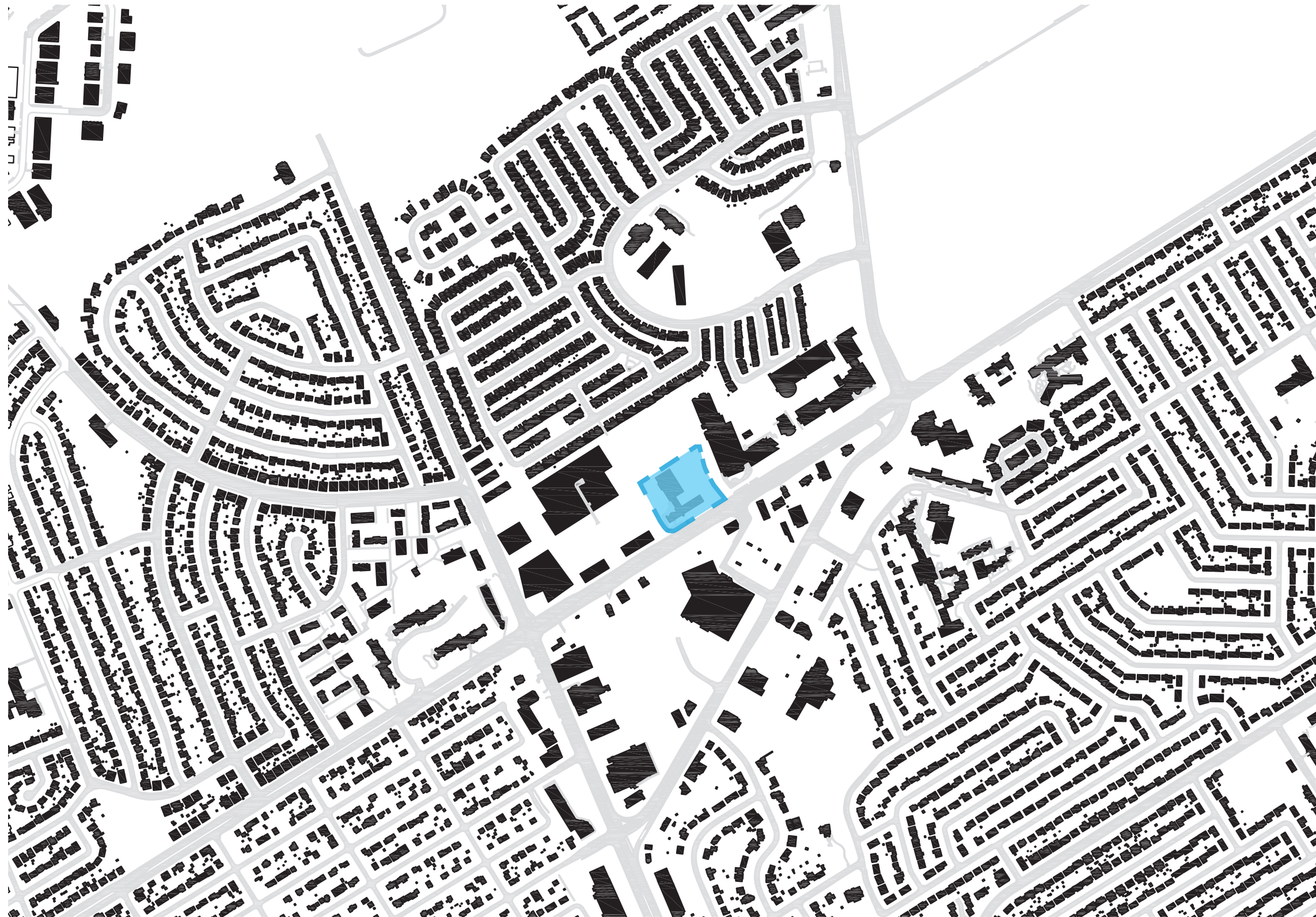

Urban Pattern

The urban blocks illustrate an inconsistent street wall with various vacant parcels, underdeveloped areas and parking lots that front arterial streets. There is a presence of big retail in close proximity to the site. The project site is located in an area that is expected to have large growth due to New Official Plan policies and the ongoing process of a Secondary Plan for the Baseline-Merivale area. These will aim to improve the street wall, increase density, mitigate surface parking and maximize the potential of surrounding sites with mixed-use developments.

SITE ANALYSIS

Characteristics of Adjacent Streets

Baseline Rd

As per Schedule C4, Baseline Rd is designated an Arterial Road. Arterial roads function as major public and infrastructure corridors in the urban communities. Along the section fronting the subject property, there is currently a government complex, commercial developments and a sidewalk. The subject property is along Baseline Road and is currently used as the Scouts Canada National Office. As per the Official Plan, the site is in a Hub designation and also along the future Bus Rapid Transit Corridor which will promote an increased height, 6-storey podiums, activating the public realm and buildings framing the street. The project site along Baseline Rd will be included in the ongoing Secondary Plan for Baseline-Merivale.

Clyde Ave

As per Schedule C4, Clyde Ave is designated an Arterial Road. Clyde Rd serves low-rise residential developments towards the northern end while serving mixed-use and commercial developments towards the southern end. Clyde Ave becomes Merivale Rd at the junction of these two arterial roads. Certain areas along Clyde Rd are included in the Hub designation as per the Official Plan and will also be included in the ongoing Secondary Plan for Baseline-Merivale to guide redevelopment.



Merivale Rd

As per Schedule C4, Merivale Rd is designated as an Arterial Road. Merivale Rd functions as a major corridor that serves a variety of uses such as automobile services, retail and restaurants. A large portion of Merivale Rd is expected for redevelopment as per the Official Plan policies and further guided by an ongoing Secondary Plan for Baseline-Merivale. These future developments will contain buildings that frame the street, activate the public realm while also respecting the nearby residential zones. Certain areas along Merivale Rd are also designated as a Hub as per the Official Plan which will further guide these redevelopment strategies.

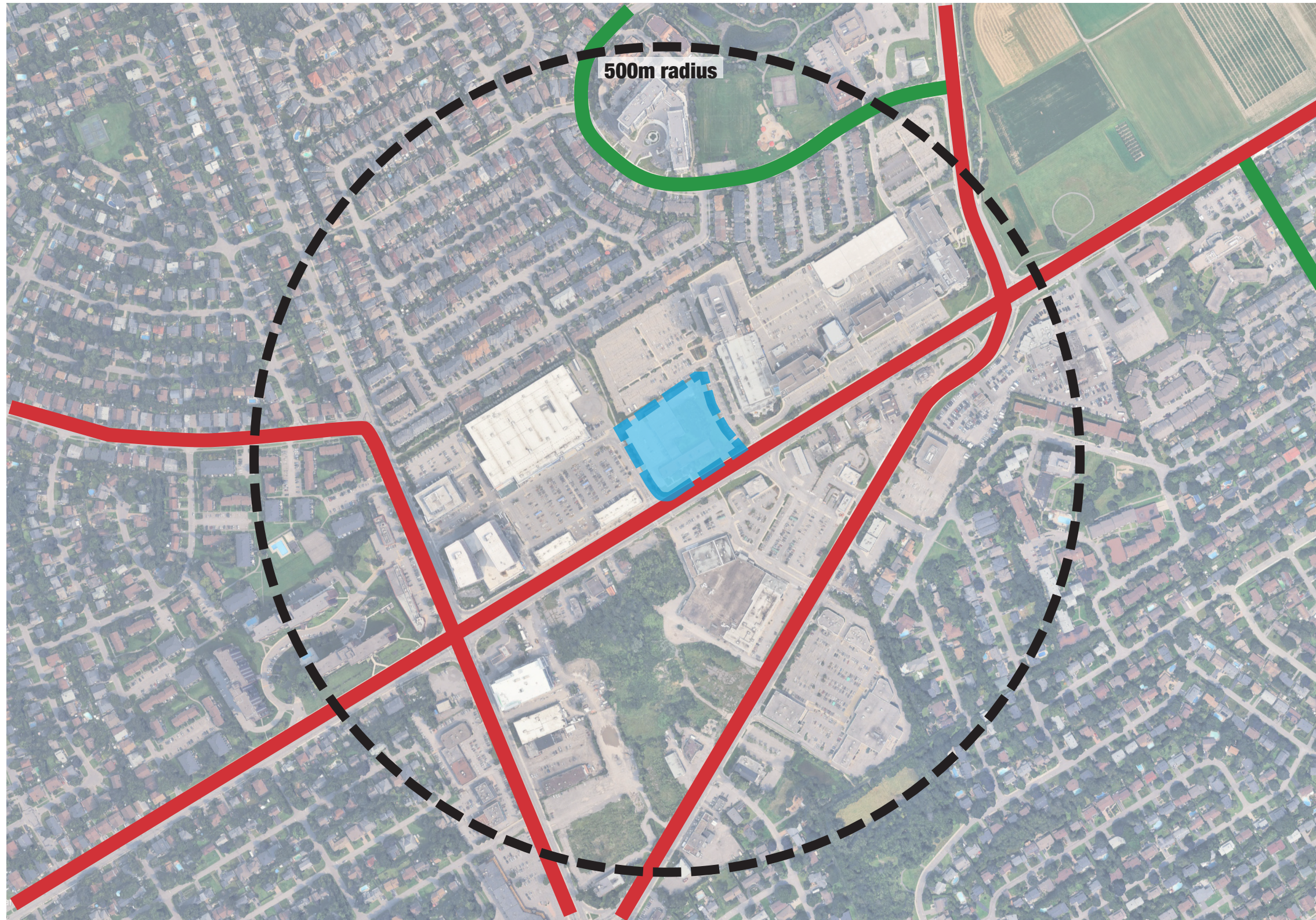



Road Network

Schedule C4-Urban Road Network identified Baseline Road, Clyde Ave and Merivale Road as Arterial Roads.

Arterial Roads are intended to function as major corridors that support the efficient movement of people and goods across the city. They are planned to accommodate a full range of travel modes including public transit, motor vehicles, pedestrians, and cyclists, and are designed to balance mobility with safety and accessibility. Where appropriate, this is achieved through the provision of sidewalks, cycling facilities, transit infrastructure, and other complete street elements.

Along these arterial roads there is no on-street parking, but most of the retail stores and services offer private parking for their customers.

Schedule C4-Urban Road Network identified certain surrounding roads as Collector Roads. Collector roads connect communities and distribute traffic between the Arterial roads and Local roads.

-  Subject Site
-  Arterial Road - Existing
-  Collector Road - Existing

Existing and Planned street network (Based on Ottawa Official Plan - Schedule C4)

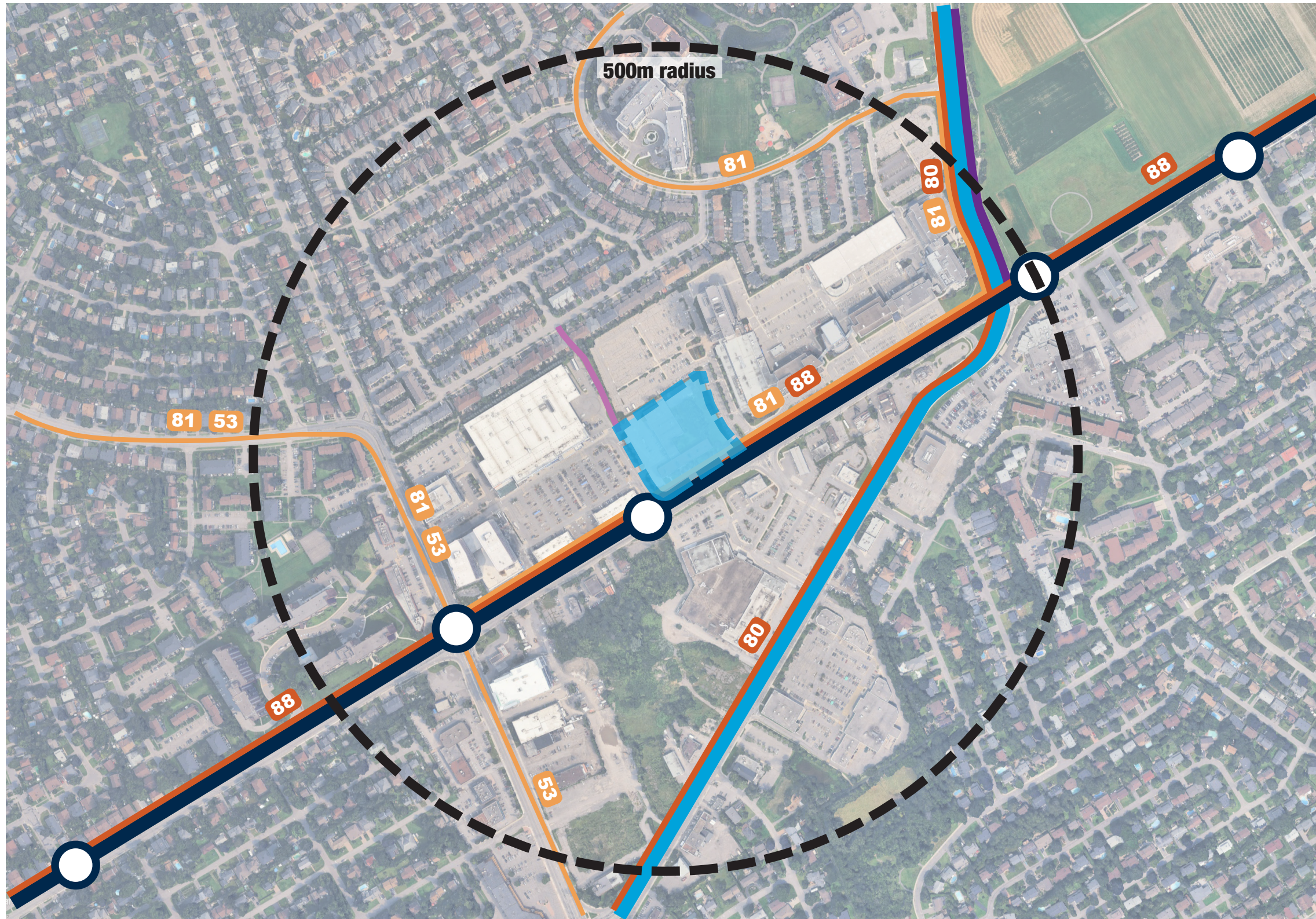

Transit Network









As per Schedule C2 of the Official Plan, the subject property has frontage along Baseline Road, a future transitway corridor. The future bus rapid transit (BRT) line proposes a BRT station at the intersection of Baseline Road and Merivale Road. This BRT line shall be integrated directly with the Confederation LRT line and the Trillium LRT Line, providing rapid access across the city. Merivale Road is also designated as a Transit Priority Corridor to improve transit circulation.

As per the OC Transpo Network map, existing transit stops along Merivale and Baseline Road service frequent routes 80 and 88. OC Transpo also services local routes 81 and 53 along Merivale Road and Clyde Avenue.

Active Transportation

As per Schedule C3 – Active Transportation Network, a painted conventional bike lane along Merivale Road offers north cycling connectivity into the larger major pathway network across the City. A network of multi-use pathways (MUP), intersect the Experimental Farm, providing separated and safe cycling across the street.

The main Arterial roads surrounding the site have pedestrian infrastructure. To the rear of the site, a pedestrian pathway connects the site to the Central Park neighbourhood along Scout Street.

-  Subject Site
-  Future Transitway Stations - At Grade
-  Future Transitway - At Grade
-  Future Transit Priority Corridor
-  Frequent Bus Route
-  Local Bus Route
-  Future Major Pathway
-  Existing Pedestrian Connection

Transit Network and Active Transportation (Based on Ottawa Official Plan - Schedules C2 and C3, and OC Transpo Network Map, Google Maps.)

POLICY CONTEXT

Design Priority Area





Design Priority Areas

As per Schedule C7-A Design Priority Areas, the subject site is identified as being within a Design Priority Area.

Design Priority Areas are locations where a higher standard of urban design is required and where development is expected to make a strong, positive contribution to the city's image, streetscape, and sense of place. These areas include locations such as main streets, arterial roads, gateways, and areas adjacent to significant public spaces.

As a result, proposals in Design Priority Areas are typically subject to a more detailed design review, including attendance at the UDRP, and must more clearly demonstrate conformity with the Official Plan's urban design policies and guidelines.

-  Subject Site
-  Corridor - Mainstreet within Design Priority Area
-  Design Priority Area







Design Priority Area (Based on Ottawa Official Plan - Schedule C7-A)



Outer Urban Transect

As per Schedule B3 - Outer Urban Transect Network of the Official Plan, the subject property has frontage along a Mainstreet Corridor and is adjacent to a future transitway station. The site is also within a Hub designation and the Evolving Neighbourhood Overlay.

Intensification will be directed along these Corridors and within the Hub designation. Since the development is within a Hub, adjacent to the future bus rapid transit, and has a right-of-way width greater than 30 metres, it could permit high-rise development generally up to 40 storeys. Development within Hubs and along Mainstreet Corridors should also activate the public realm and frame the street.

-  Subject Site
-  Corridor - Mainstreet
-  Corridor - Minor
-  Hub
-  Evolving Neighbourhood
-  Greenspace
-  Transitway Station

Outer Urban Transect Network (Based on Ottawa Official Plan - Schedule B3)

POLICY CONTEXT
Proposed Development in Existing Context



POLICY CONTEXT
Proposed Development in Existing Context



POLICY CONTEXT
Proposed Development in Existing Context



POLICY CONTEXT
Proposed Development in Existing Context



POLICY CONTEXT
Proposed Development in Planned Context



POLICY CONTEXT
Proposed Development in Planned Context



POLICY CONTEXT
Proposed Development in Planned Context



POLICY CONTEXT
Proposed Development in Planned Context



POLICY CONTEXT

Baseline-Merivale Secondary Plan

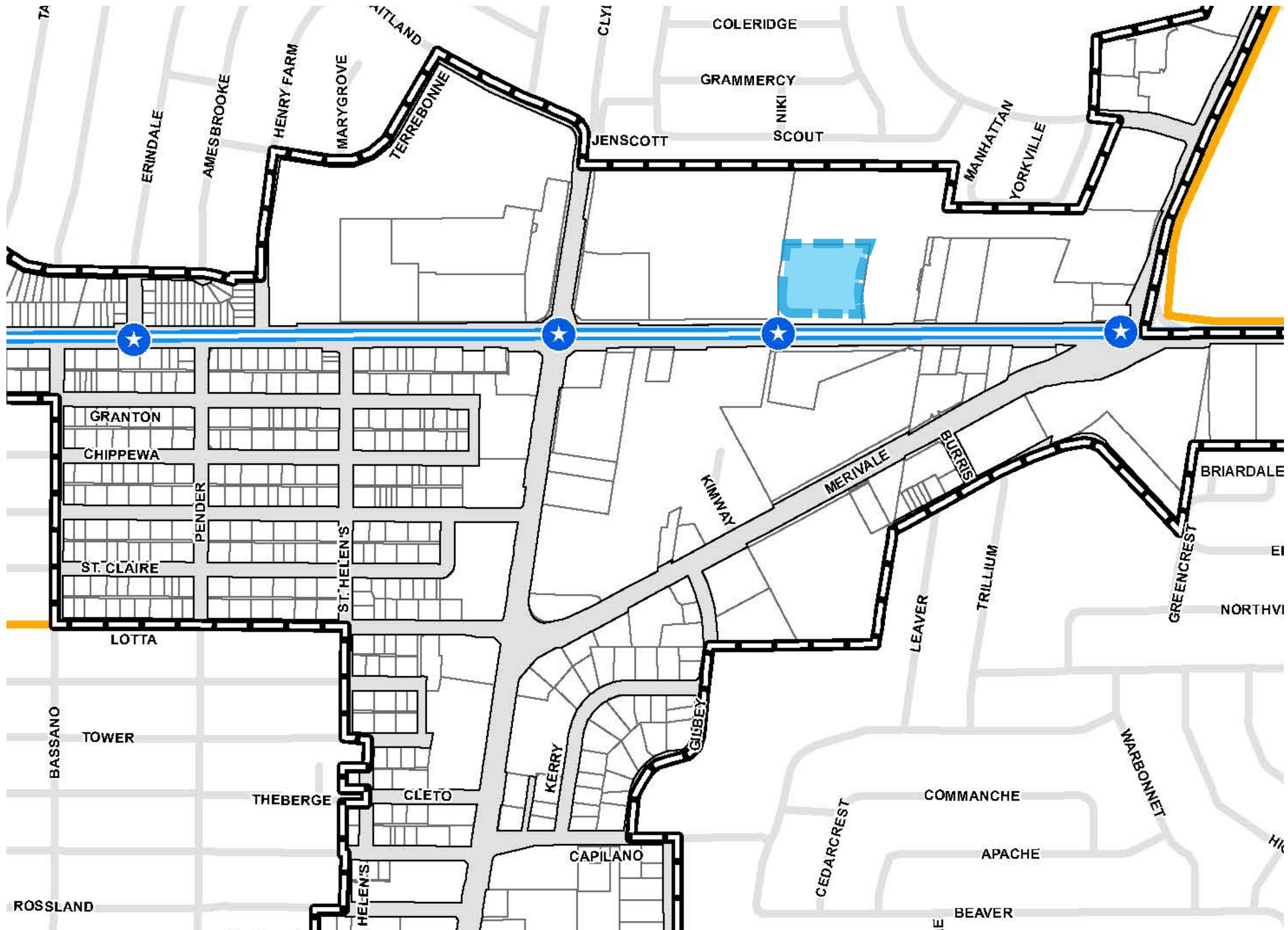

The Secondary Plan study is being undertaken to guide private development and public infrastructure investment in an area expected to experience significant growth in the coming decades. The study will establish a vision and planning framework to accommodate intensification while advancing the City's objectives related to housing, mobility, transit, health, climate resilience, and economic development.

The draft study area is generally centred around the intersection of Baseline Road and Clyde Road, extending approximately one kilometre east and west along Baseline Road, and south along Merivale Road to the Beachburg rail corridor. It primarily includes lands designated as Hub and Corridor, as well as select Neighbourhood-designated lands within the Evolving Neighbourhood Overlay.

The subject site is located at the central-north end of the draft study area. The project team will continue to monitor and remain informed as the Secondary Plan process evolves to ensure ongoing alignment with emerging policy direction.

A Block Plan illustrating potential future development in the surrounding area was requested as part of the UDB Terms of Reference. However, the information typically conveyed through a Block Plan is already comprehensively addressed through the 3D massing visualizations and the Planned Context description slide. As such, the preparation of an additional Block Plan graphic would be redundant. This approach is also consistent with the City's recent efforts to reduce and streamline the Terms of Reference.

 Subject Site

Baseline-Merivale Secondary Plan - Draft Study Area

DESIGN DEVELOPMENT

Design Evolution

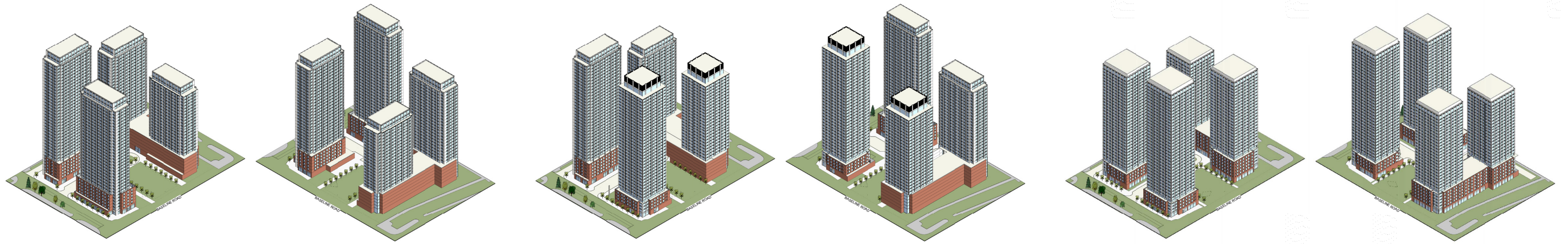

Massing Evolution:

We studied various different tower masses on this site, and ultimately decided that using point towers was the most effective use of the site. This allowed us to place four towers, with ample separation, at the four corners of the site, with the most minimal shadowing and the least site coverage. This scheme also avoids the wall effect of two slab towers placed next to each other in the same orientation.

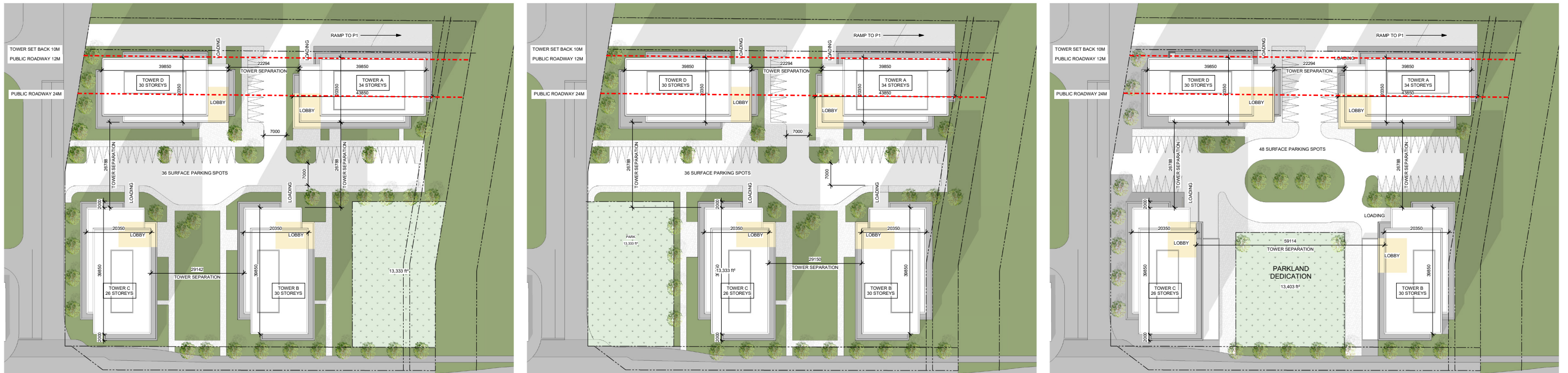

Park Placement:

We tried several different park placements along Baseline Road. We feel that the most successful of these schemes has the park located in the centre of the site, with towers on either side. This allows for a close connection between the commercial spaces located in buildings A and B with the existing commercial centre to the west, as well as allowing it to be protected from the busy intersection at the corner of the site. Having the park centralized allows it to be a feature of the site, and closely connected to all of the buildings. While it is located between two high rise buildings, there is ample sun exposure throughout the day as a result of the southern exposure.

DESIGN DEVELOPMENT

Tower Massing

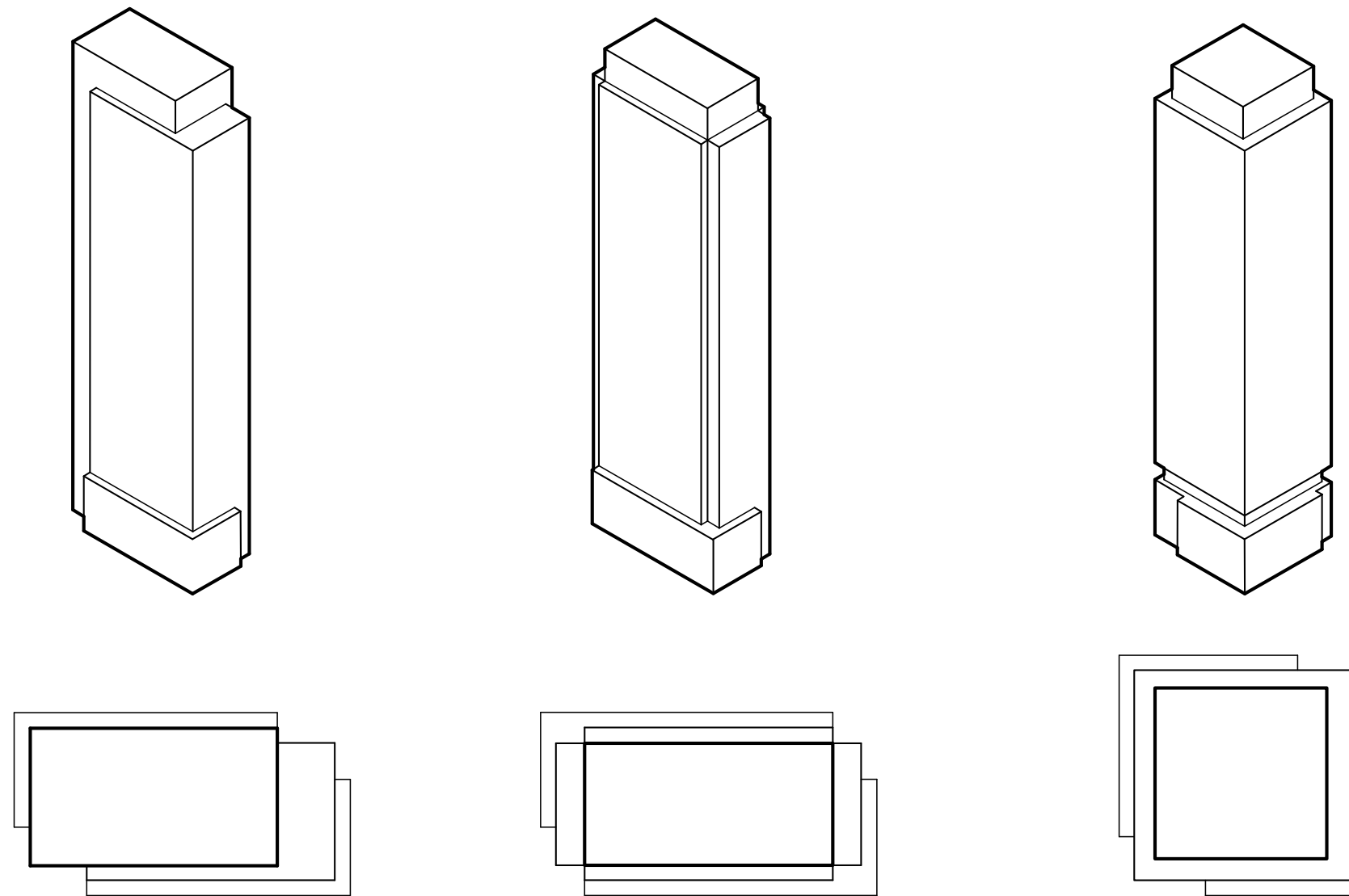

The proposed development takes advantage of the site's location along a major arterial road with a future proposed Bus Rapid Transit route. This type of intensification is consistent with the Official Plan's goals of intensifying along major transit and connectivity networks, as well as providing more density in the housing being built in the outer urban transects.

The proposed development has been designed in accordance with the City's High-rise guidelines, with ample tower separations, between 27m to 45m, with forms that have been chosen to reduce shadowing, and servicing removed from the streets and contained in the centre of the site. Each of the proposed towers is comprised of three distinct parts, the Base, a 4-storey podium; middle, a window wall clad tower that has been set back from the base; and Crown, with a corner step back design leading to the party room and mechanical penthouse.

The proposed floor plate is slightly over the 750m² area as recommended floor plate area in the guidelines. However, the point tower design, and the increased tower separations, will mitigate any perceived adverse impacts of the slight increase.

To add to the project's visual interest at a neighbourhood scale each of the four towers have been designed with different total building height. The tallest building, at 40 storeys, is located along

Baseline Road, at the corner of Baseline and the shared access way, with the shortest, at 28 storeys, is located at the north east corner of the site. This height difference implies a transition to the north and east neighbourhoods that lie beyond the adjacent sites.

SITE PLAN

With Grading

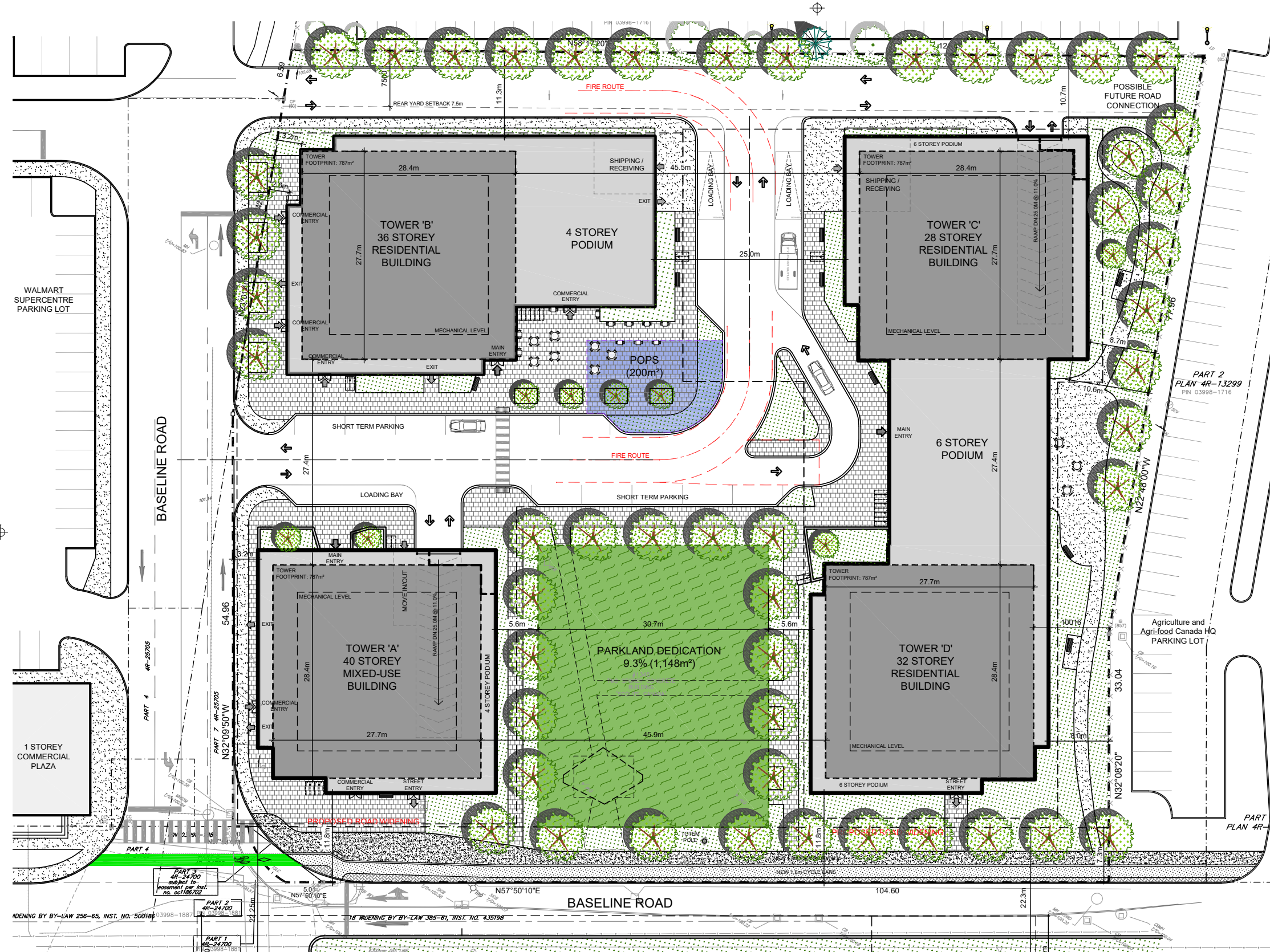

PROJECT INFORMATION		
Zoning By-law: 2008-250 Consolidation	AMS (436)	SITE AREA (PURCHASED) 13,158.6 m ² 141,538 ft ²
		ROW PROTECTION 839.3 m ² 8,924 ft ²
		SITE AREA (DEVELOPABLE) 12,319.3 m ² 132,604 ft ²

ZONING	REQUIRED	PROVIDED
ZONING	AMS (436)	
DENSITY: THE CUMULATIVE TOTAL GFA MUST NOT EXCEED (MAXIMUM)	1.26 = 15,550m ²	7.20 = 87,738.5m ²
BUILDING HEIGHT	BUILDING 'A' 25.0m BUILDING 'B' 25.0m BUILDING 'C' 25.0m BUILDING 'D' 25.0m	40 STOREYS / 125.0m 36 STOREYS / 113.0m 28 STOREYS / 89.0m 32 STOREYS / 101.0m
TOWER FOOTPRINT (GUIDELINE ONLY) NOT INCLUDES BALCONIES	750m ²	787m ²
TOWER SEPARATION (GUIDELINE ONLY)	23.0m	27.4m
FRONT YARD SETBACK	0.0m	11.8m
INTERIOR SIDE YARD SETBACK (WEST & EAST SIDE)	0.0m	2.6m / 8.0m
REAR YARD SETBACK (MIXED USE BUILDING)	7.5m	11.3m
PARKLAND SETBACK (ABOVE GRADE ONLY)	3.0m	5.6m
TOTAL RESIDENTIAL UNIT COUNT		1,269
PARKING - RESIDENTIAL - 0.5 PER UNIT		611
PARKING - VISITOR ONLY (AFTER 12 UNITS PER BLDG.) - 0.2 PER UNIT		244
PARKING - COMMERCIAL (VARIES WITH USE) - 1.25 TO 10.0 PER 100m ² GFA		12 - 80
PARKING - RESIDENTIAL MAXIMUM: 1.75 PER UNIT		2,255
PARKING - COMMERCIAL RETAIL ONLY MAXIMUM: 3.6 PER 100m ² GFA		136
BICYCLE PARKING - RESIDENTIAL - 0.5 PER UNIT		635
BICYCLE PARKING - COMMERCIAL - 1 PER 250m ² GFA		4
aisle & DRIVEWAY MINIMUM / MAXIMUM WIDTH	6.0m / 6.7m	6.0m / 6.7m
AMENITY AREA - TOTAL PER UNIT - 6.0m ²		9,930 m ²
AMENITY AREA - 50% COMMUNAL PER UNIT - 3.0m ²		6,330 m ²
PARKLAND DEDICATION AREA - 10% LOT AREA		1,148.0m ²

CAR PARKING		BUILDING STATISTICS	
MINIMUM REQUIRED		BUILDING 'A' - 40 Storeys	
RESIDENCE (AFTER 12 UNITS) - 0.5 PER DWELLING UNIT	611	GROSS BUILDING AREA	32,141.9 m ² / 345,919 ft ²
VISITOR (AFTER 12 UNITS) - 0.2 PER DWELLING UNIT	244	(GFA IS BASED ON 75% CONSTRUCTION AREA)	
COMM. USE (UNITS OVER 500m ²) - 1.25 TO 10.0 PER 100m ² GFA	24	TOWER FOOTPRINT	787.0 m ² / 8,467 ft ²
TOTAL	879	UNIT COUNT	370
MAXIMUM PERMITTED		VEHICLE PARKING	144
RESIDENCE + VISITOR - 1.75 PER DWELLING UNIT	2,221	BICYCLE PARKING	190
COMM. USE - 3.6 PER 100m ² GFA	34	COMMERCIAL AREA	2,770 m ²
TOTAL	2,255		

PROVIDED		BUILDING 'B' - 36 Storeys	
RESIDENCE - 0.54 PER DWELLING UNIT	684	GROSS BUILDING AREA	30,455.9 m ² / 329,763 ft ²
VISITOR - 0.2 PER DWELLING UNIT	244	(GFA IS BASED ON 75% CONSTRUCTION AREA)	
COMM. USE - 2.5 TO 10.0 PER 100m ² GFA	24	TOWER FOOTPRINT	787.0 m ² / 8,467 ft ²
TOTAL	952	UNIT COUNT	339
LOCATION		VEHICLE PARKING	212
BUILDING 'A' UIG GARAGE	280	BICYCLE PARKING	173
BUILDING 'B' UIG GARAGE	208	COMMERCIAL AREA	780.8 m ² / 7,328 ft ²
BUILDING 'C' & 'D' UIG GARAGE	453		
SURFACE PARKING	11		
TOTAL	952		

BICYCLE PARKING		BUILDING 'C' - 28 Storeys	
REQUIRED		TOTAL BUILDING AREA	21,788.5 m ² / 233,847 ft ²
RESIDENCE - 0.5 PER UNIT	635	(GFA IS BASED ON 75% CONSTRUCTION AREA)	
COMMERCIAL - 1 PER 250m ² GFA (611 m ²)	4	TOWER FOOTPRINT	787.0 m ² / 8,467 ft ²
TOTAL	639	UNIT COUNT	242
PROVIDED		VEHICLE PARKING - RESIDENTIAL ONLY	210
RESIDENCE - 0.5 PER UNIT	640	BICYCLE PARKING	112
COMMERCIAL	4		
TOTAL	650		

AMENITY SPACE		BUILDING 'D' - 32 Storeys	
PHASE 1: BUILDING 'A' PRIVATE =	1,200 m ²	TOTAL AREA	28,170.9 m ² / 303,259 ft ²
PHASE 2: BUILDING 'B' PRIVATE =	900 m ²	(GFA IS BASED ON 75% CONSTRUCTION AREA)	
PHASE 1: BUILDING 'C' & 'D' PRIVATE =	1,500 m ²	TOWER FOOTPRINT	787.0 m ² / 8,467 ft ²
PHASE 1: BUILDING 'A' COMMUNAL =	1,030 m ²	UNIT COUNT	318
PHASE 2: BUILDING 'B' COMMUNAL =	1,360 m ²	VEHICLE PARKING - RESIDENTIAL ONLY	243
PHASE 2: BUILDING 'C' & 'D' COMMUNAL =	3,940 m ²	BICYCLE PARKING	165
TOTAL	6,330 m ²		
TOTAL COMMUNAL =	6,330 m ²		
REQUIRED - 6.0M ² PER UNIT (1,269) =	7,614 m ²		
REQUIRED COMMUNAL @ 50% =	3,807 m ²		

LOT COVERAGE		BUILDING AREA	
BUILDING FOOTPRINT 'A'	1,001.0 m ² / 8.13%	CITY OF OTTAWA ZONING AREA GFA'S BASED ON 75% CONSTRUCTION AREA	
BUILDING FOOTPRINT 'B'	1,352.2 m ² / 10.98%	BUILDING 'A'	32,141.9 m ² / 345,919 ft ²
BUILDING FOOTPRINT 'C'	953.8 m ² / 7.44%	BUILDING 'B'	30,455.9 m ² / 329,763 ft ²
BUILDING FOOTPRINT 'D'	1,513.6 m ² / 12.29%	BUILDING 'C'	21,788.5 m ² / 233,847 ft ²
DRIVING SURFACE =	2,352.6 m ² / 19.18%	BUILDING 'D'	28,170.9 m ² / 303,259 ft ²
LANDSCAPE SURFACE =	3,788.1 m ² / 30.75%	TOTAL AREA ABOVE GRADE	112,459.3 m ² / 1,210,761 ft ²
POPS =	200.0 m ² / 1.62%		
PARKLAND DEDICATION =	1,148.0 m ² / 9.30%		
TOTAL	12,319.3 m ² / 100.00%		

LOT PHASING AREA		UNIT MIX	
PHASE 1: BUILDING 'A' =	2,746.5 m ² / 29.30%	BLDG. A	0
PHASE 2: BUILDING 'B' =	2,528.3 m ² / 26.52%	BLDG. B	0
PHASE 3: BUILDING 'C' & 'D' =	5,803.7 m ² / 62.18%	BLDG. C	0
PARKLAND DEDICATION =	1,148.0 m ² / 9.30%	BLDG. D	0
TOTAL	12,319.3 m ² / 100.00%	TOTAL	0



SITE PLAN
SCALE: 1: 500
PLOT DATE: Thursday, February 19, 2026

ISSUED FOR: UDRP PRESENTATION
(March 6, 2026)



1345 BASELINE ROAD
OTTAWA ONTARIO



SHEET #
SP-1
PROJ. # 2503

PROJECT STATISTICS

TOWER A					
Building Areas	Construction	Municipal	Residential	Common	Commercial
	345, 973 SF	269,851 SF	268,086 SF	75,117 SF	4,053 SF
Building Height	40 storeys				
Amenity area	Private	Public			
	12,920 SF	11,124 SF			
Parking	Residential	Visitor	Bicycle		
	250	30	190		
Unit Type	1 Bedroom	1 Bed + Study	2 Bedroom	2 Bed + Study	Total
	71	151	142	6	370

TOWER B					
Building Areas	Construction	Municipal	Residential	Common	Commercial
	327,932 SF	255,787 SF	250,524 SF	62,883 SF	7,328 SF
Building Height	36 storeys				
Amenity area	Private	Public			
	9,690 SF	14,647 SF			
Parking	Residential	Visitor	Bicycle		
	178	30	175		
Unit Type	1 Bedroom	1 Bed + Study	2 Bedroom	2 Bed + Study	Total
	63	132	138	6	339

TOWER C					
Building Areas	Construction	Municipal	Residential	Common	Commercial
	233,467 SF	182,104 SF	170,331 SF	56,206 SF	0 SF
Building Height	28 storeys				
Amenity area	Private	Public			
	8,075 SF	16,308 SF			
Parking	Residential	Visitor	Bicycle		
	423	30	125		
Unit Type	1 Bedroom	1 Bed + Study	2 Bedroom	2 Bed + Study	Total
	44	98	97	3	242

TOWER D					
Building Areas	Construction	Municipal	Residential	Common	Commercial
	303,229 SF	219,359 SF	231,137 SF	69,947 SF	0 SF
Building Height	32 storeys				
Amenity area	Private	Public			
	8,075 SF	26,116 SF			
Parking	Residential	Visitor	Bicycle		
	Combined with tower C	Combined with Tower C	190		
Unit Type	1 Bedroom	1 Bed + Study	2 Bedroom	2 Bed + Study	Total
	57	145	109	7	318

PLANS

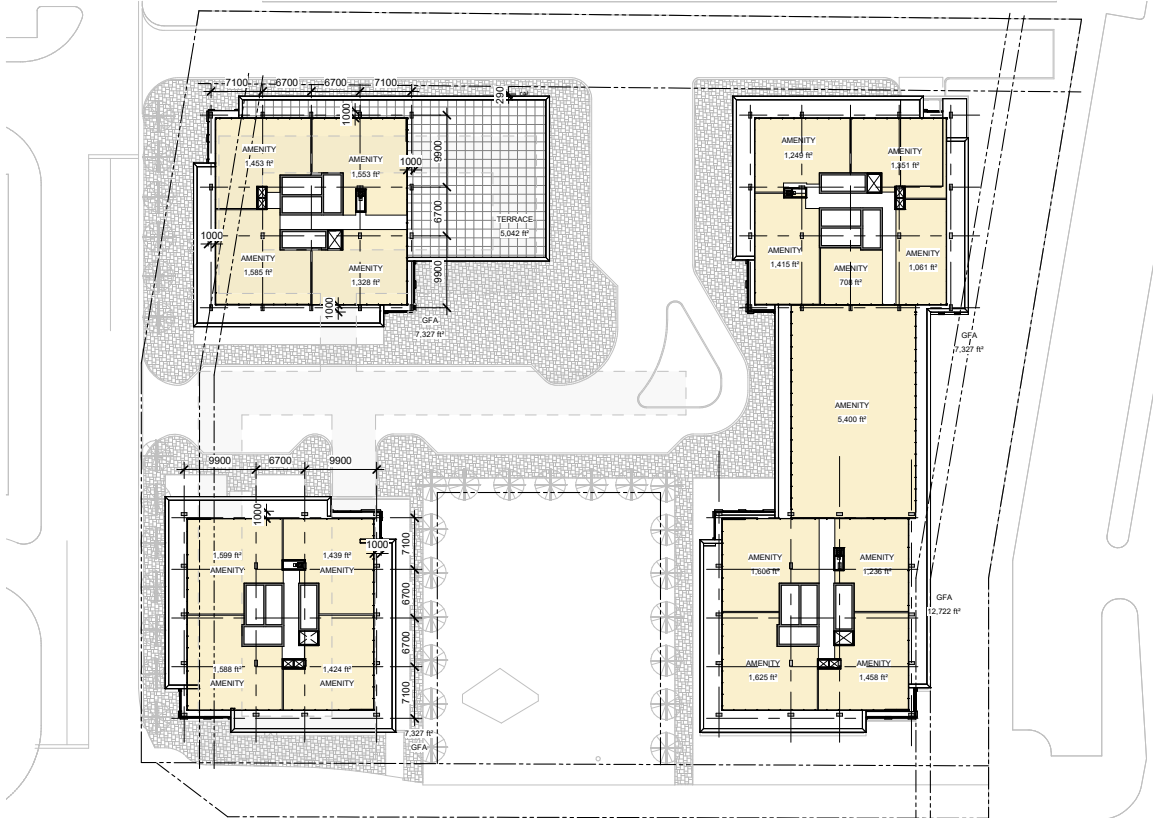

L5 Plan - Amenity Floor

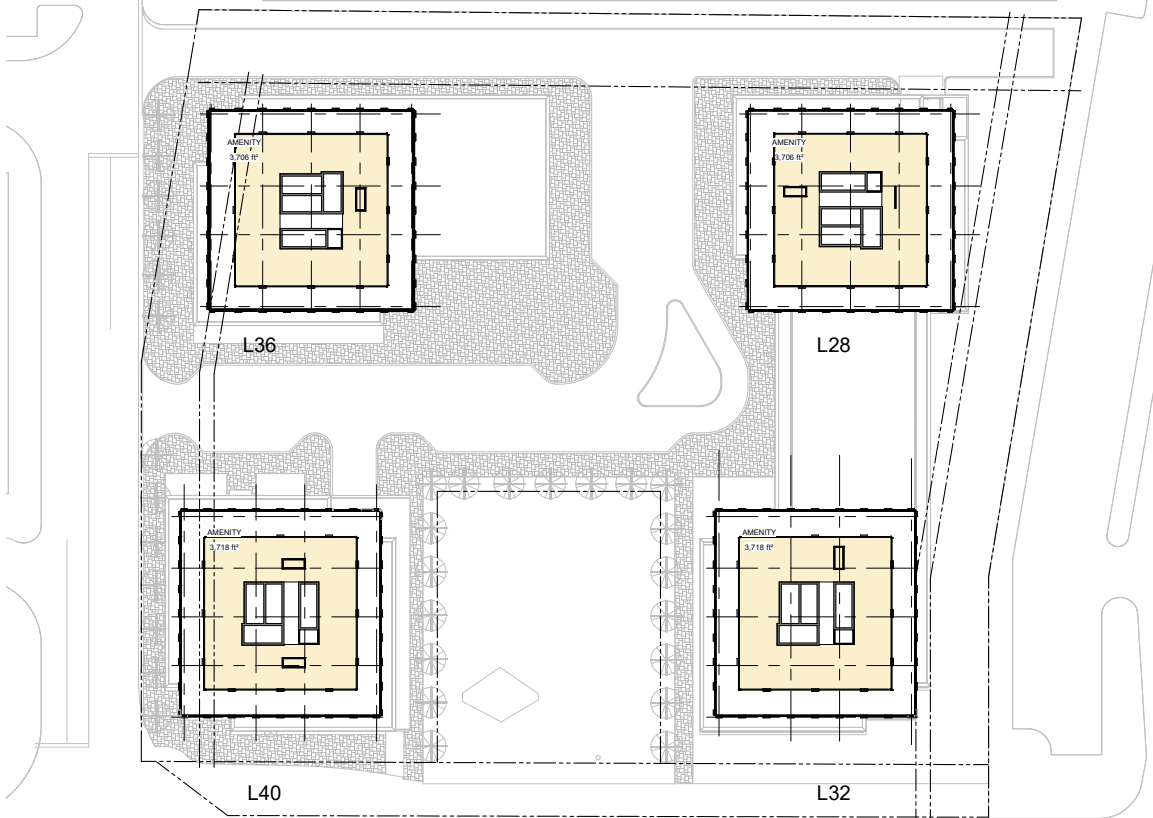

Plan - Penthouse Amenity Floor



Plan - Typical Tower

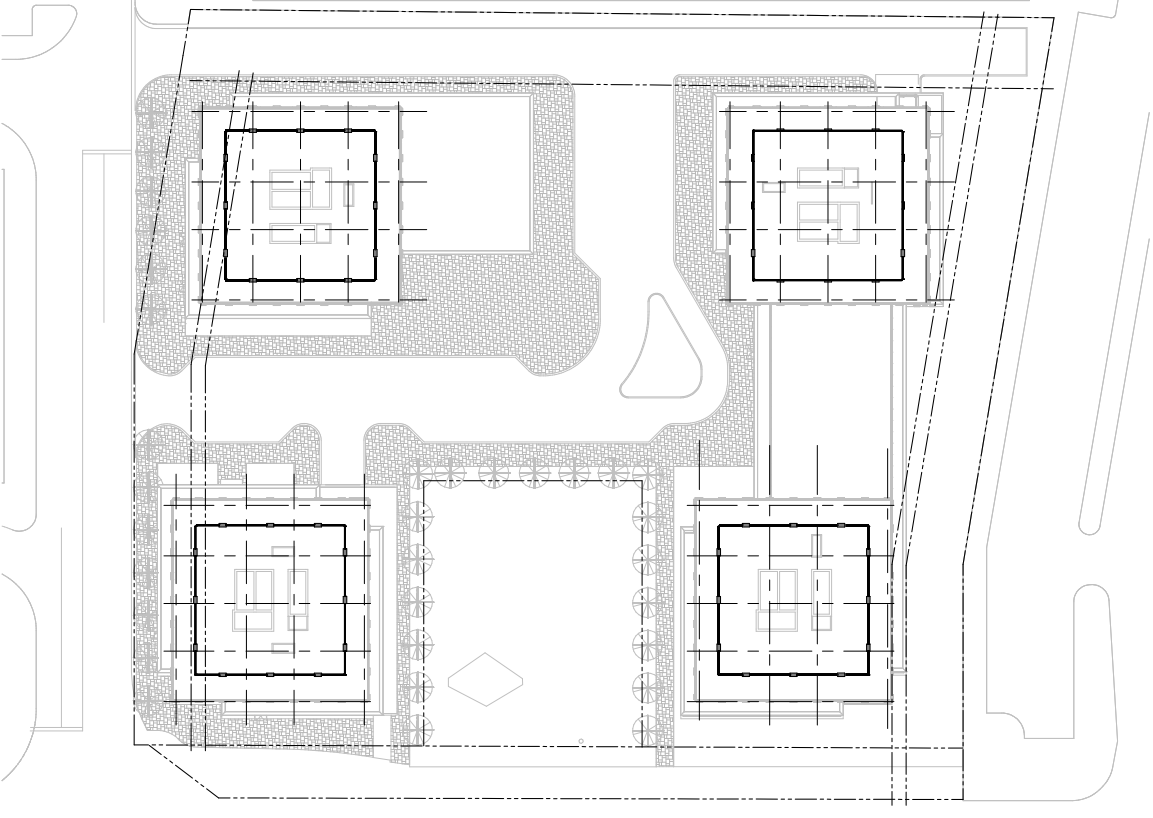

Mechanical Penthouse Plan

SITE ELEVATION

South and West Elevations

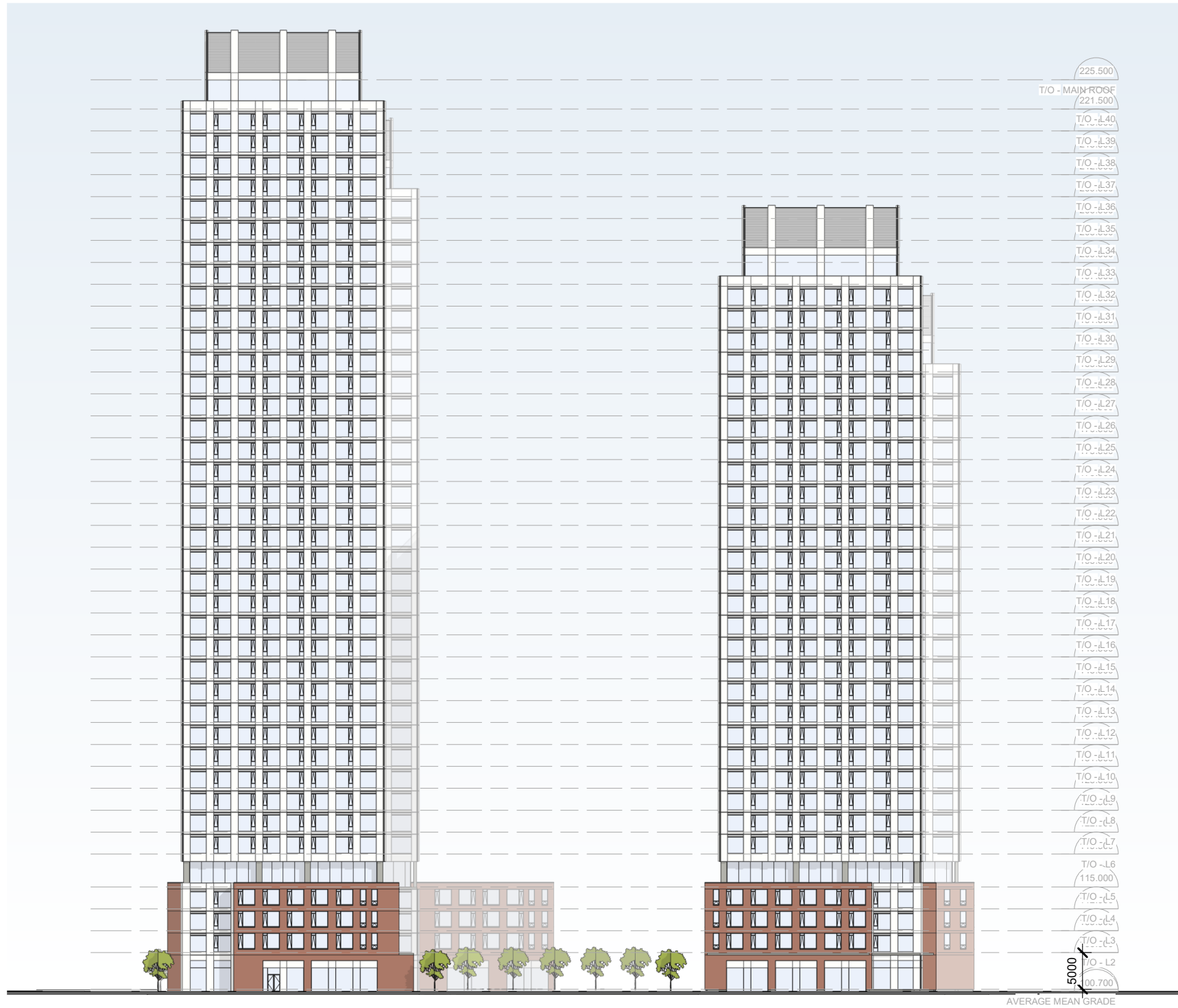

South Elevation

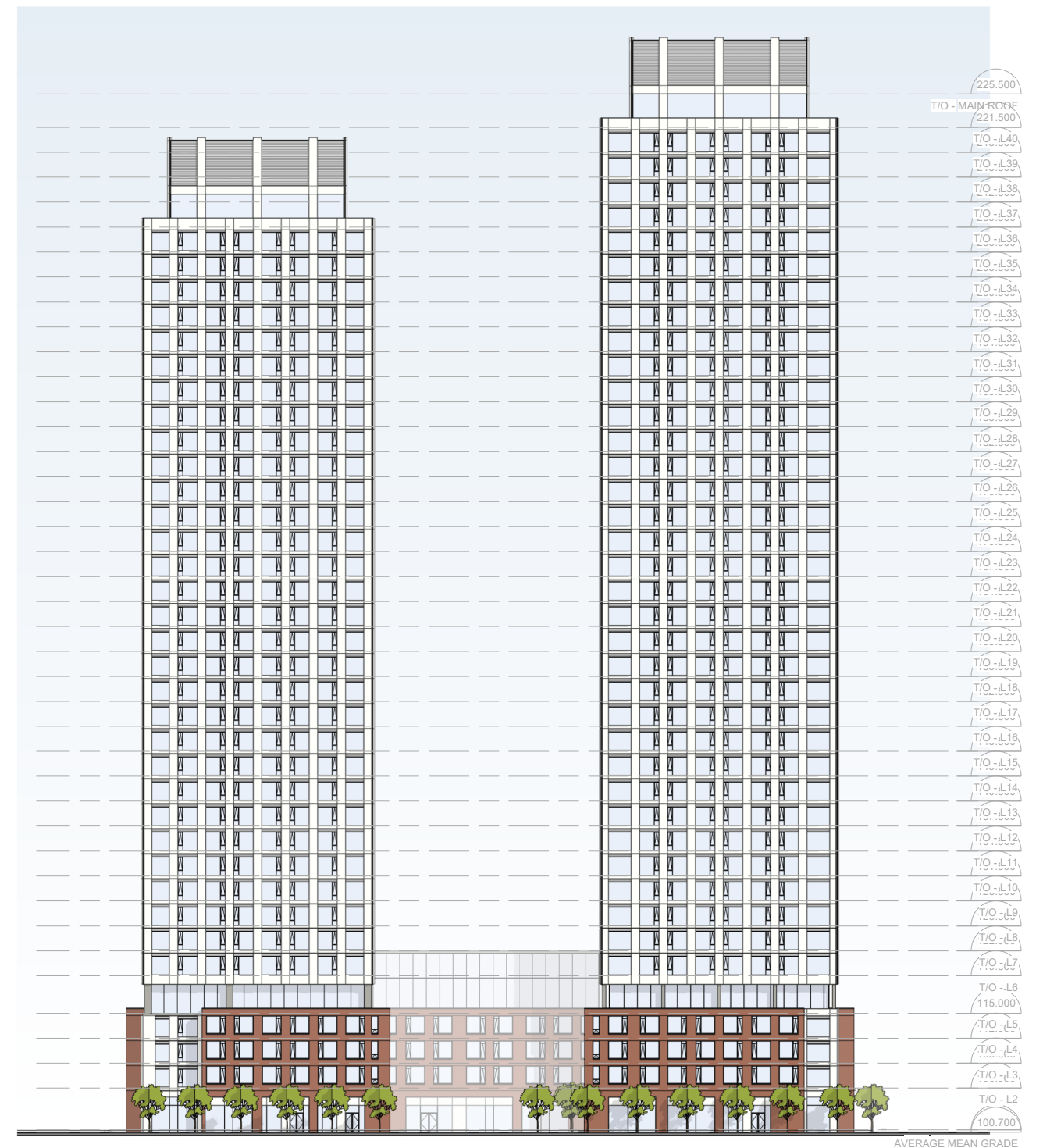

West Elevation

SITE ELEVATION

North and East Elevations

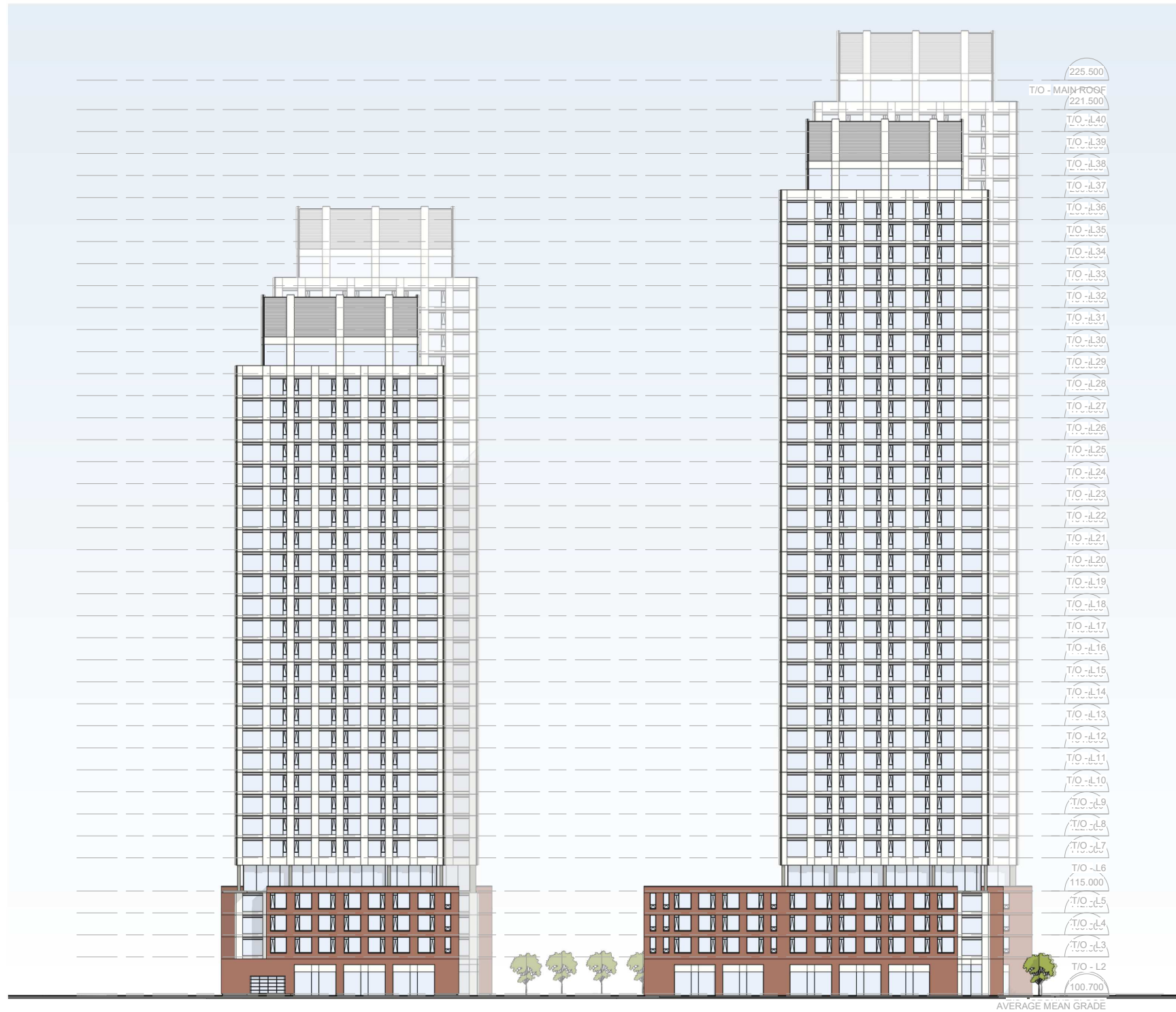

North Elevation

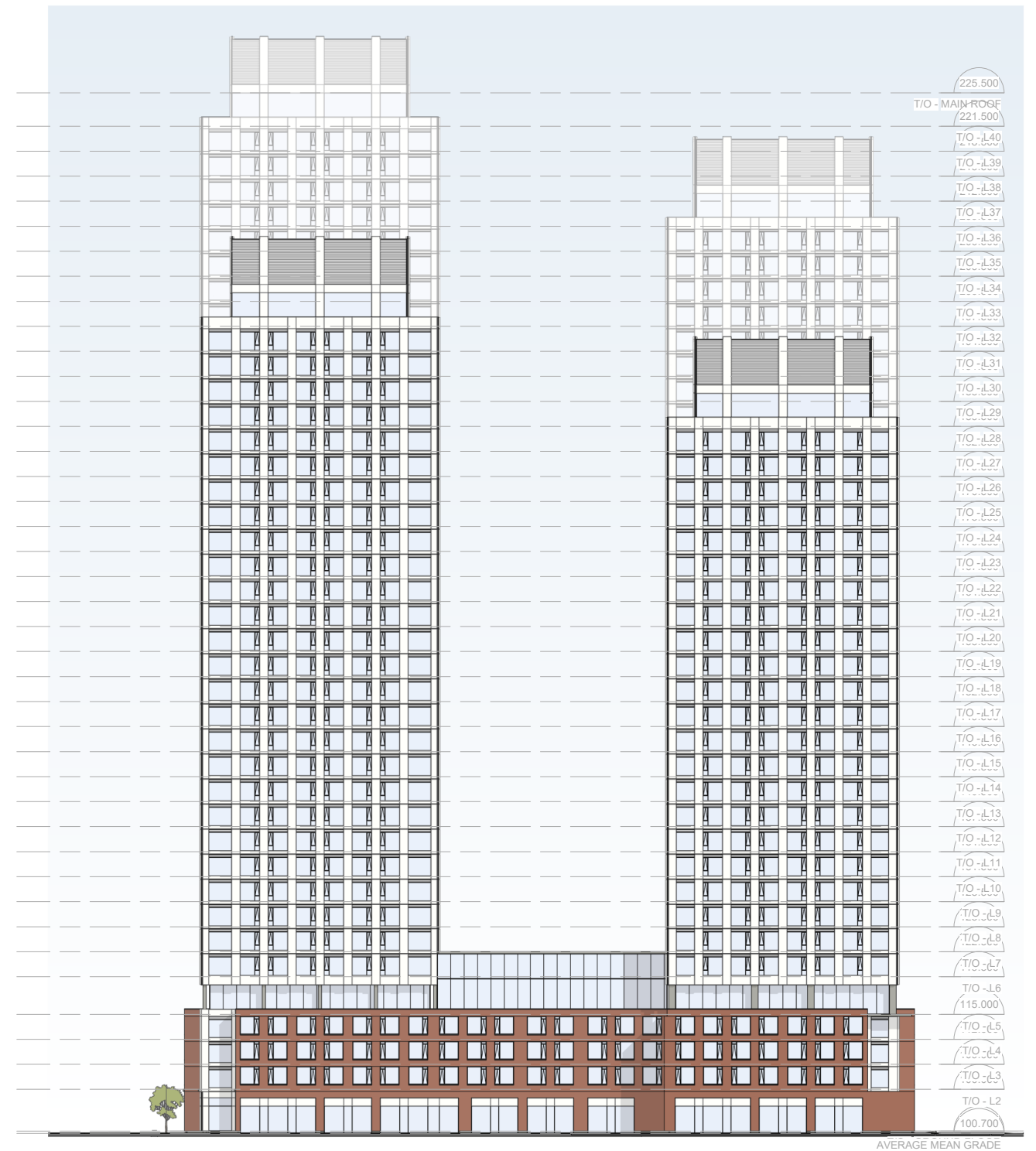

East Elevation

STUDIES

Balcony Options



ELEVATION

Blow-up elevation with materials

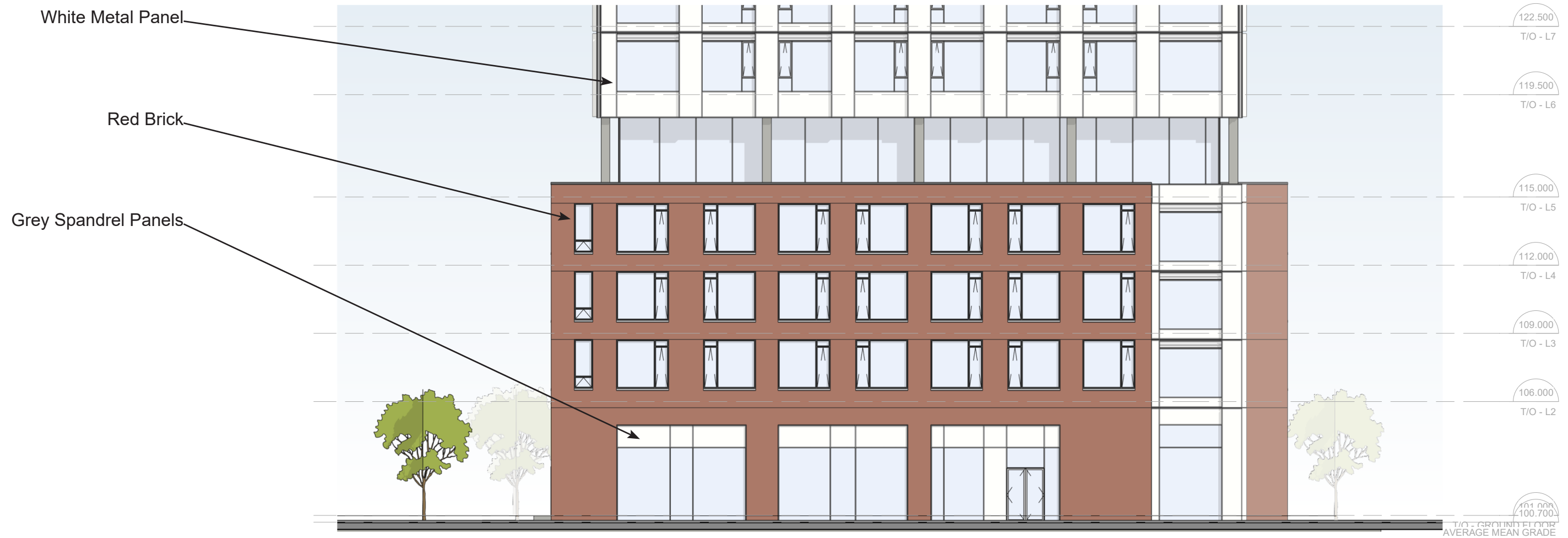

Sustainable design features currently being contemplated:

- High Density developments in close proximity to public transit
- Higher use of public transit will reduce greenhouse gas emissions
- Reduction of heat island effect with use of cool roofs.
- All required parking located below grade maximizing landscape areas
- EV car charging
- EV car sharing
- Every parking stall will be EV ready
- Bike parking within the ground floor and parking garage
- Site Lighting will be Dark Star compliant
- Bird friendly design guidelines incorporated into the podium design.
- All internal and external communal spaces will be designed to accessible standards
- Incorporation of pedestrian pathways that are continuous and universally accessible into landscape design along all site frontages connecting to POPS and public park
- 15% of the residential units are proposed to be accessible barrier-free units.

SITE CONTEXT

Street Sections



Baseline Road



Access Road

SITE CONTEXT

Perspective Images - Park View



SITE CONTEXT

Perspective Images- Entry View



AERIAL VIEW
Axonometric View of the Full Site

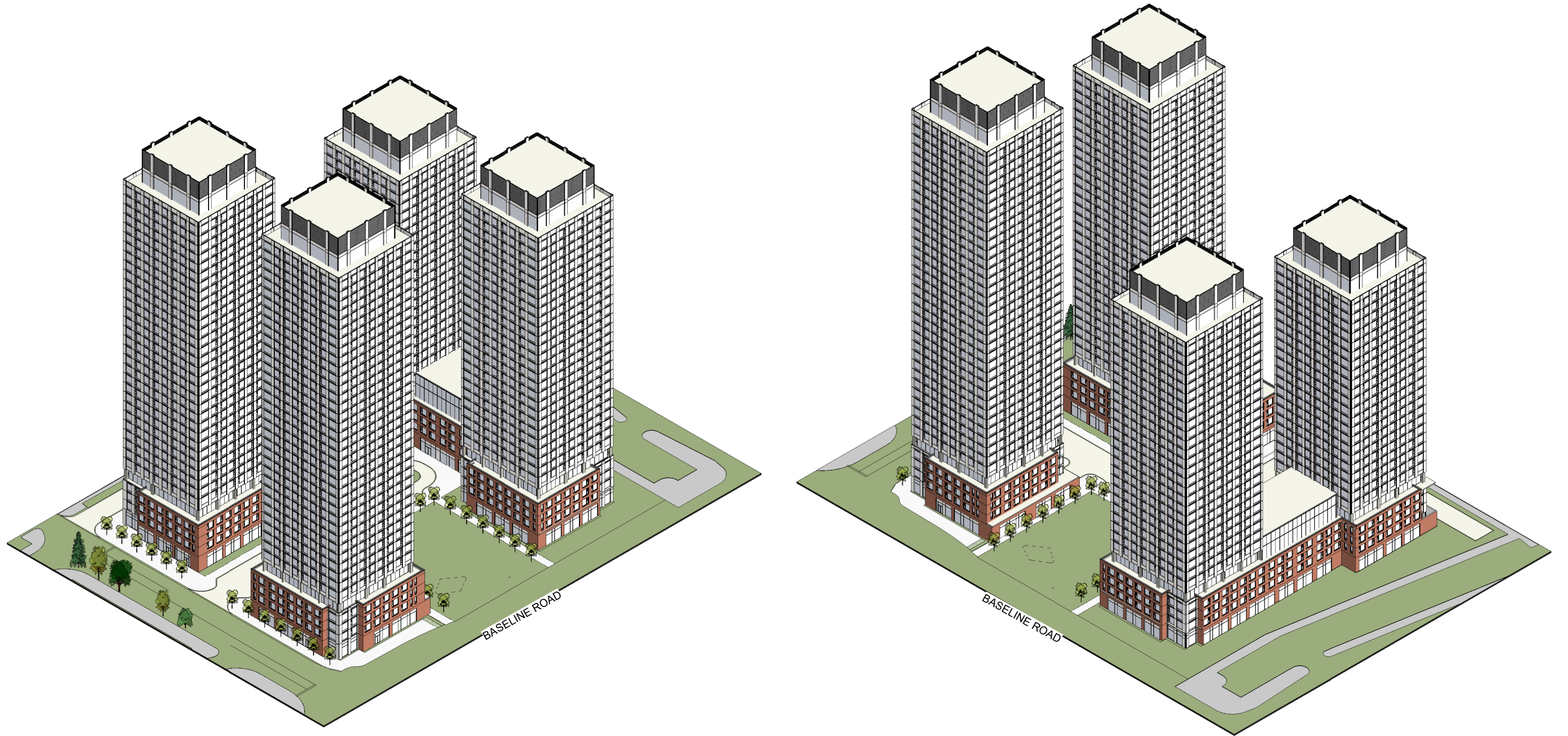

SHADOW ANALYSIS

June 21st

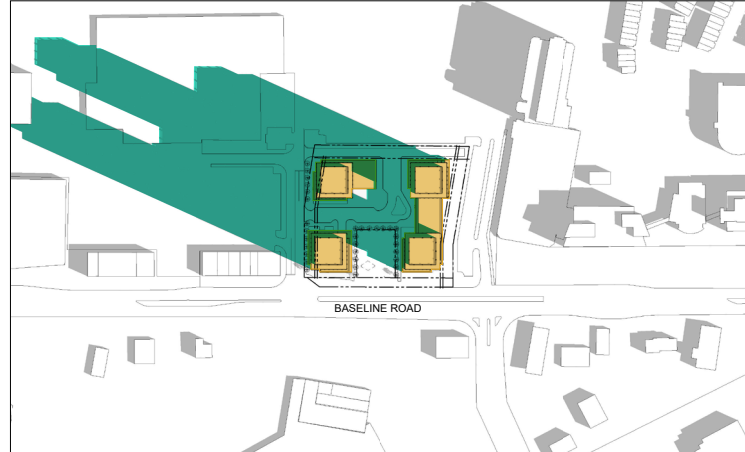

1345 BASELINE ROAD SHADOW STUDY
JUNE 21ST - 8:00



1345 BASELINE ROAD SHADOW STUDY
JUNE 21ST - 9:00



1345 BASELINE ROAD SHADOW STUDY
JUNE 21ST - 10:00

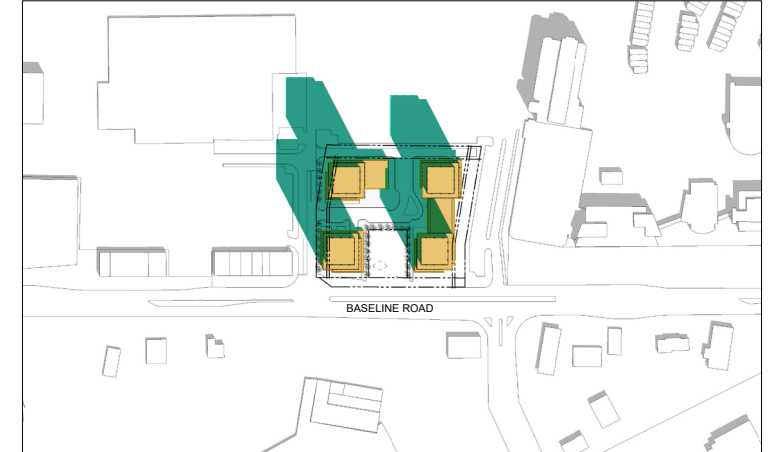

1345 BASELINE ROAD SHADOW STUDY
JUNE 21ST - 11:00



1345 BASELINE ROAD SHADOW STUDY
JUNE 21ST - 12:00



1345 BASELINE ROAD SHADOW STUDY
JUNE 21ST - 13:00



1345 BASELINE ROAD SHADOW STUDY
JUNE 21ST - 14:00

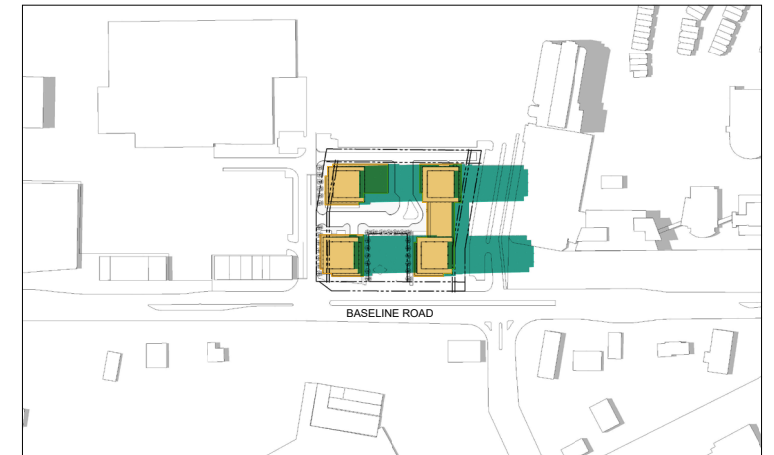

1345 BASELINE ROAD SHADOW STUDY
JUNE 21ST - 15:00



1345 BASELINE ROAD SHADOW STUDY
JUNE 21ST - 16:00

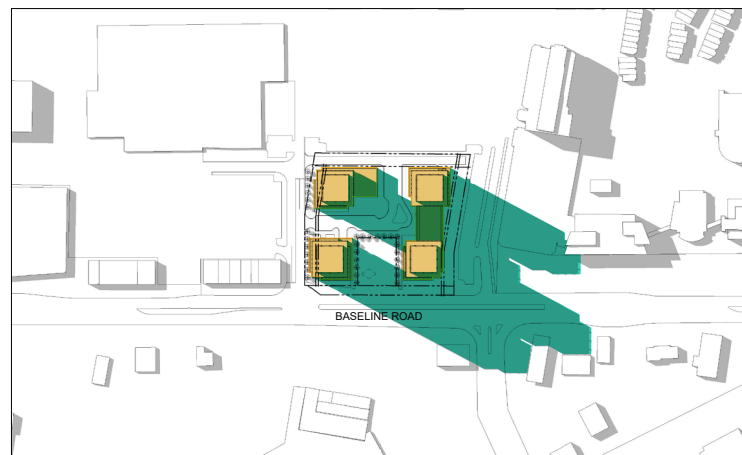

1345 BASELINE ROAD SHADOW STUDY
JUNE 21ST - 17:00



1345 BASELINE ROAD SHADOW STUDY
JUNE 21ST - 18:00

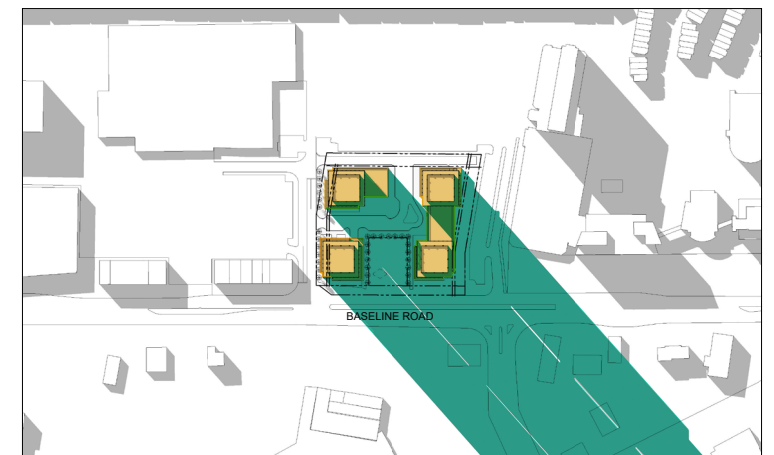

1345 BASELINE ROAD SHADOW STUDY
JUNE 21ST - 19:00

SHADOW ANALYSIS

Sept/ Mar 21st



1345 BASELINE ROAD SHADOW STUDY
SEPTEMBER 21ST - 8:00

1345 BASELINE ROAD SHADOW STUDY
SEPTEMBER 21ST - 9:00

1345 BASELINE ROAD SHADOW STUDY
SEPTEMBER 21ST - 10:00

1345 BASELINE ROAD SHADOW STUDY
SEPTEMBER 21ST - 11:00



1345 BASELINE ROAD SHADOW STUDY
SEPTEMBER 21ST - 12:00

1345 BASELINE ROAD SHADOW STUDY
SEPTEMBER 21ST - 13:00

1345 BASELINE ROAD SHADOW STUDY
SEPTEMBER 21ST - 14:00

1345 BASELINE ROAD SHADOW STUDY
SEPTEMBER 21ST - 15:00

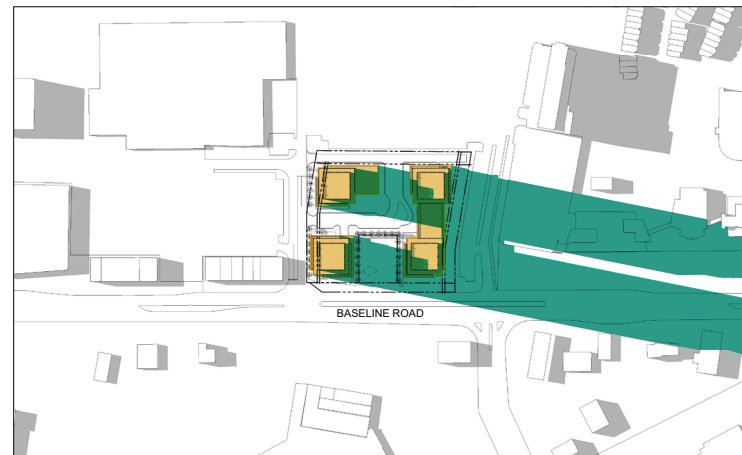

1345 BASELINE ROAD SHADOW STUDY
SEPTEMBER 21ST - 16:00

1345 BASELINE ROAD SHADOW STUDY
SEPTEMBER 21ST - 17:00

1345 BASELINE ROAD SHADOW STUDY
SEPTEMBER 21ST - 18:00

SHADOW ANALYSIS

Dec 21st

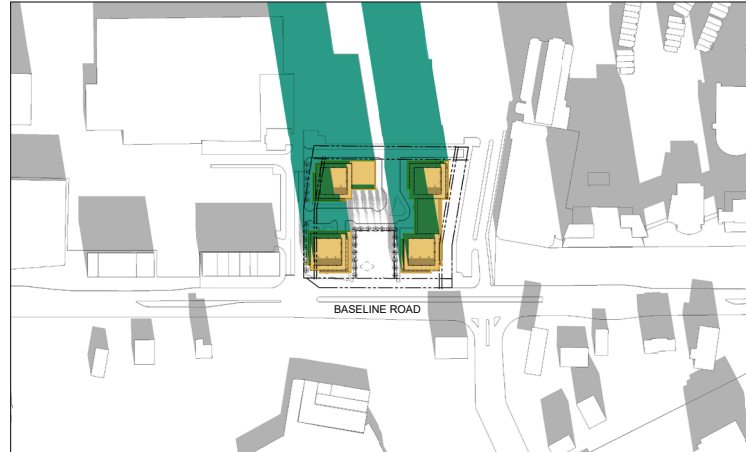

1345 BASELINE ROAD SHADOW STUDY
DECEMBER 21ST - 9:00

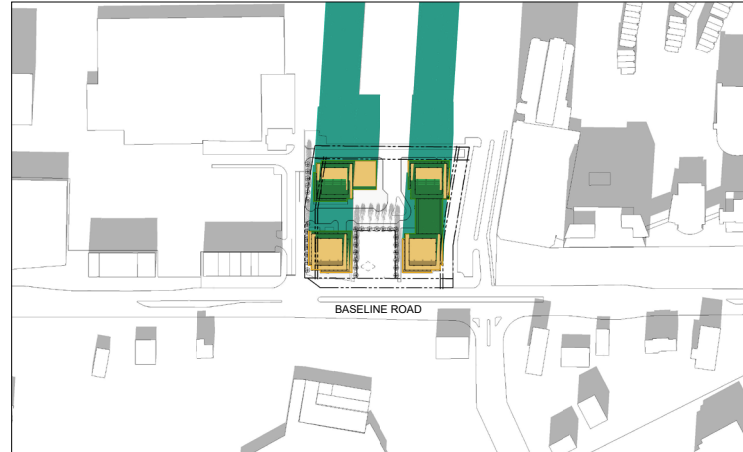

1345 BASELINE ROAD SHADOW STUDY
DECEMBER 21ST - 10:00



1345 BASELINE ROAD SHADOW STUDY
DECEMBER 21ST - 11:00

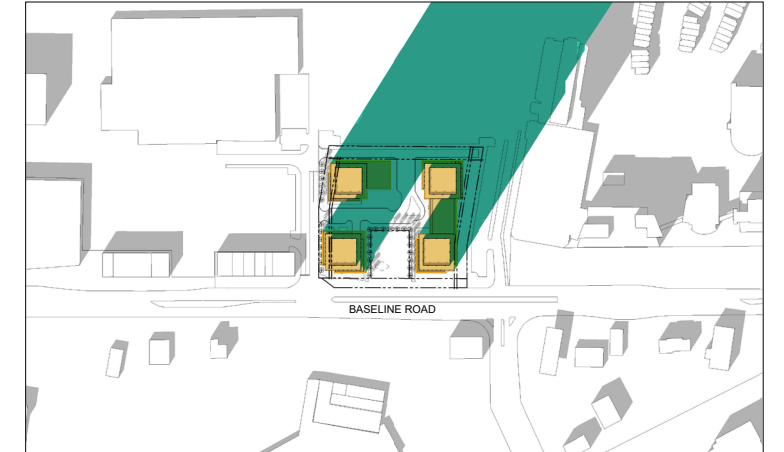

1345 BASELINE ROAD SHADOW STUDY
DECEMBER 21ST - 12:00



1345 BASELINE ROAD SHADOW STUDY
DECEMBER 21ST - 13:00



1345 BASELINE ROAD SHADOW STUDY
DECEMBER 21ST - 14:00



1345 BASELINE ROAD SHADOW STUDY
DECEMBER 21ST - 15:00

LANDSCAPE PLAN

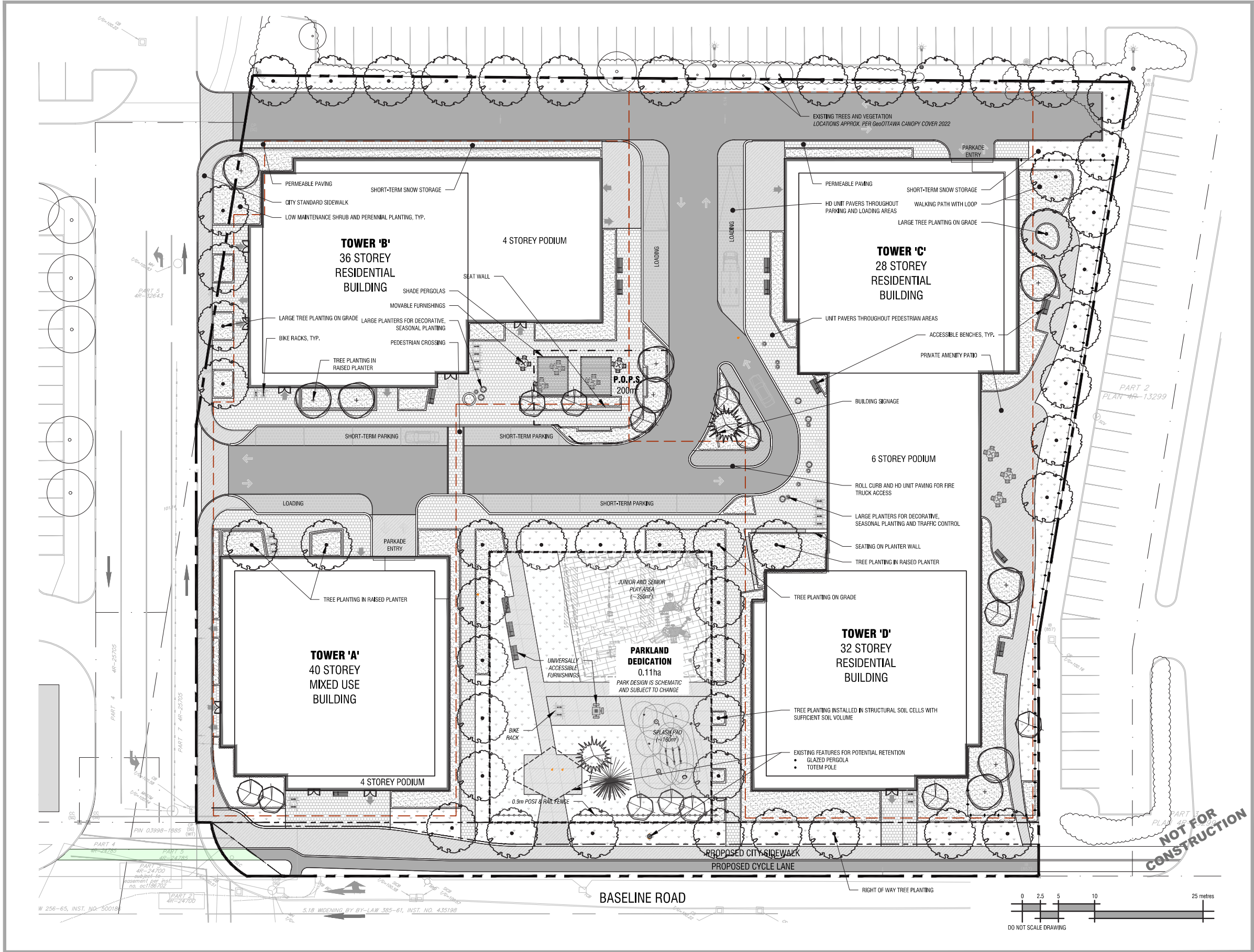

Copyright Reserved
 The Copyrights to all designs and drawings are the property of Fotenn Consultants Inc. Unauthorised reproduction or use is forbidden. DO NOT SCALE DRAWING

Copyright réservés
 Les droits d'auteur à tous les modèles et dessins sont la propriété de Fotenn Consultants Inc. Reproduction ou utilisation non autorisée est interdite. NE PAS L'ÉCHELLE DE DESSIN

Client / Client
BERTONE DEVELOPMENT CORPORATION

- Legend / Légende
- PROPERTY LINE
 - - - EXTENT OF UNDERGROUND GARAGE
 - - - EXTENT OF PARKLAND DEDICATION
 - - - LIMIT OF P.O.P.S.
 - (Tree symbols) EXISTING TREES AND VEGETATION ESTIMATED LOCATIONS PER GeoTOWNA 2022 CANOPY COVER
 - (Circle with dot) PROPOSED DECIDUOUS TREE PLANTING
 - (Circle with star) PROPOSED CONIFEROUS TREE PLANTING
 - (Grid pattern) CIP CONCRETE
 - (Square with dots) UNIT PAVERS
 - (Square with horizontal lines) UNIT PAVERS - HEAVY DUTY
 - (Square with diagonal lines) ASPHALT PAVING
 - (Dotted pattern) LAWN
 - (Square with vertical lines) PLANTING AREA
 - (Square with cross) ACCESSIBLE BENCH WITH THIRD ARMREST
 - (Square with vertical lines) BIKE RACKS

00	Issue for UDRP	2026/02/19
rev'n	description / la description	yyyy/mm/dd
FOTENN Planning + Design 420 O'Connor Street Ottawa, ON, CANADA K2P 1W4 613.730.5706 fotenn.com		

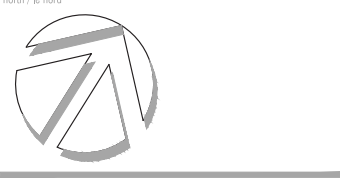

project / projet
1345 BASELINE

LANDSCAPE CONCEPT PLAN

designed / conçu BM / DF	drawn / dessiné BM	reviewed / examiné DF
date		project number / No. du projet 25001

drawing number / No. du dessin
L1

NOT FOR CONSTRUCTION

1345 Baseline Road

Architectural Design Report

UDRP

2026-03-06



la/architecture



BERTONE
ARCHITECTURE
CORPORATION

FOTENN