



URBAN FORESTRY & FOREST MANAGEMENT CONSULTING

P.O. Box 13593, STN. KANATA, OTTAWA, ON K2K 1X6
TELEPHONE: (613) 850-2475
WEBSITE: WWW.IFSASSOCIATES.CA

April 8, 2026

Concorde Properties
408 Tweedsmuir Avenue
Ottawa, ON
K1Z 5N5

RE: TREE CONSERVATION REPORT FOR 114 RICHMOND ROAD, OTTAWA

This Tree Conservation Report (TCR) was prepared by IFS Associates Inc. (IFS) on behalf of Concorde Properties in support of their proposed development of 114 Richmond Road in Ottawa. The need for this report is related to trees protected under the City of Ottawa's Tree Protection By-law (By-law No. 2020-340). The By-law reflects Section 4.8.2. of the City of Ottawa's Official Plan which calls for the retention of the City's urban forestry canopy and, in particular, large healthy trees.

Under the tree protection by-law, a TCR is required for all plans of subdivision, site plan control applications, common elements condominium applications, and vacant land condominium applications where there is a tree of 10 cm in diameter at breast height (DBH) or greater on a site and/or if there is a tree on an adjacent site that has a critical root zone (CRZ) extending onto a development site. Trees of any size on adjacent City lands must also be documented in a TCR. A "tree" is defined in the By-law as any species of woody perennial plant, including its root system, which has reached or can reach a minimum height of at least 450 cm at physiological maturity. The CRZ is calculated as DBH x 10 cm.

The development proposed for this presently open property includes the construction of one four-storey apartment building and six blocks of stacked townhouses with underground parking. Proposed fire access route, walkways, surface vehicle parking and amenity areas are to share the property. An existing paved walkway ('Nun's Walk') will be retained.

The inventory in this report details the assessment of all individual trees on the subject property and adjacent private properties and City of Ottawa land. Field work for this report was completed in March 2026.

The approval of this tree conservation report by the City and the issuing of a permit authorizes the removal of approved trees. *Importantly, although this report may be used to support the application for a tree removal permit, it does not by itself constitute permission to remove trees or begin site clearing activities. No such work should occur before a tree removal permit is issued authorizing the injury or destruction of a tree in accordance with the By-law. Further, the removal of any trees shared with or fully on neighbouring properties will require written permission of the adjacent landowner.*



TREE SPECIES, CONDITION, SIZE AND STATUS

Table 1 below details the species, ownership, size (diameter), condition and status of the individual and groups of trees on the subject and adjacent properties. Each of these trees is referenced by the numbers plotted on the tree conservation plans on pages 7 and 8 of this report.

Table 1. Species, ownership, diameter, condition and status of trees at 114 Richmond Road

Tree No.	Tree species	Ownership ¹	DBH ² (cm)	CRZ ³	SRZ ⁴	Distance to excavation ⁵	Tree Condition; Age Class; Condition Notes; Species Origin & Preservation Status (to be removed or preserved and protected)
1	White cedar (<i>Thuja occidentalis</i>) & white spruce (<i>Picea glauca</i>)	City owned	Cedar 9avg; spruce 45avg	4.5	1.4	>5	Fair; mature; cedars generally in multi-stemmed clusters with fair to good crown densities, annual increments and needle colour; seven spruce with single dominant stems and leaders with poor to fair crown densities, annual increments and needle colour; one spruce is fully dead; native species; to be preserved and protected
2	Silver maple (<i>Acer saccharinum</i>)	City owned	85.6 (at 0.5m)	8.5	2.6	<2	Fair, mature; central stem with multiple competing laterals starting at 1m; generally upright form; native species; to be preserved and protected
3	Freman maple (<i>Acer x freemanii</i>)	Co-owned with City	23.1	-	-	-	Good; maturing; co-dominant leaders at 4m; moderate basal sprouting; cultivar; to be removed (conflicts with construction)
4	Silver maple (<i>Acer saccharinum</i>)	Co-owned with City	66.3	-	-	-	Good; mature; suppressed central stem with multiple competing laterals starting at 2.5m; crown mildly asymmetric towards west; native species; to be removed (conflicts with construction)
5	Freman maple (<i>Acer x freemanii</i>)	Co-owned with City	29.5	-	-	-	Good; maturing; co-dominant leaders at 4m; moderate basal sprouting; cultivar; to be removed (conflicts with construction)

Table 1. Cont.

Tree No.	Tree species	Ownership ¹	DBH ² (cm)	CRZ ³	SRZ ⁴	Distance to excavation ⁵	Tree Condition; Age Class; Condition Notes; Species Origin & Preservation Status (to be removed or preserved and protected)
6	Silver maple (<i>Acer saccharinum</i>)	Co-owned with City	59.3	-	-	-	Good; mature; central stem with multiple competing laterals on north and west starting at 2m; native species; to be removed (conflicts with construction)
7	Silver maple (<i>Acer saccharinum</i>)	Co-owned with City	54.3	-	-	-	Fair; mature; strong central stem with competing laterals on east and south at 3m and west at 1.75m – the union of which is so weak that failure is imminent; crown mildly asymmetric towards west; native species; to be removed (conflicts with construction)
8	Silver maple (<i>Acer saccharinum</i>)	Co-owned with City	53.9	-	-	-	Fair; mature; central stem with co-dominant leaders at 4.5m; competing laterals at 2.5m on north and 4m on northwest; recent woodpecker activity at 4.5-5m on south side of central stem; crown mildly asymmetric towards west; native species; to be removed (conflicts with construction)
9	Silver maple (<i>Acer saccharinum</i>)	Co-owned with City	57.6	-	-	-	Fair; mature; tri-stemmed at 1m; fourth stem removed at 1m on east; east stem bisects at 2m; very broad crown; some storm damaged branches require pruning for safety; native species; to be removed (conflicts with construction)
10	Silver maple (<i>Acer saccharinum</i>)	Co-owned with City	61.3	-	-	-	Fair; mature; strongly upright form; co-dominant stems 2.25m with inclusion ridge at union; crown asymmetric towards east; native species; to be removed (conflicts with construction)
11	Honey-locust (<i>Gleditsia triacanthos</i>)	City owned	43.7	4.4	1.3	>5	Fair; mature; central stem with competing lateral at 5.5m on north and suppressed lateral at 4m on southeast; crown asymmetric towards north; introduced species to Eastern Ontario; to be preserved and protected

Table 1. Cont.

Tree No.	Tree species	Owner-ship ¹	DBH ² (cm)	CRZ ³	SRZ ⁴	Distance to excavation ⁵	Tree Condition; Age Class; Condition Notes; Species Origin & Preservation Status (to be removed or preserved and protected)
12	Honey-locust (<i>Gleditsia triacanthos</i>)	City owned	38.6	3.9	1.2	>5	Fair; mature; co-dominant stems at 4.5m – both bisect at 7 and 8.5m; crown moderately asymmetric towards north; introduced species to Eastern Ontario; to be preserved and protected
13	Honey-locust (<i>Gleditsia triacanthos</i>)	City owned	33.3	3.3	1.0	>5	Fair; mature; central dominant stem and leader; generally upright form; competing laterals starting at 6.5m – height of living crown; introduced species to Eastern Ontario; to be preserved and protected
14	Honey-locust (<i>Gleditsia triacanthos</i>)	City owned	38.3	3.8	1.2	>5	Fair; mature; tri-dominant leaders at 7.5m; suppressed lateral at 6m on west; introduced species to Eastern Ontario; to be preserved and protected
15	Sugar maple (<i>Acer saccharum</i>)	City owned	35.2	3.5	1.1	>3	Fair; mature; strongly upright form; co-dominant stems at 2.25m with inclusion ridge at union; crown asymmetric towards east due to influence of tree #16; native species; to be preserved and protected
16	Little-leaf linden (<i>Tilia cordata</i>)	City owned	48.5	4.9	1.5	<2	Fair; mature; generally upright form; tri-stemmed at 3.5-4m, all bisect between 5-5.5m; broad crown; introduced species; to be preserved and protected
17	Little-leaf linden (<i>Tilia cordata</i>)	City owned	35.7	-	-	-	Fair; mature; poor form – central stem with competing lateral at 2.25m on south and suppressed lateral at 1.5m on southwest; introduced species; to be removed (conflicts with proposed sidewalk)
18	Ginkgo (<i>Ginkgo biloba</i>)	City owned	22.3	2.2	0.7	>2	Fair; mature; central dominant upright main stem; suppressed lateral at 3m on south is dead; introduced species; to be preserved and protected
19	Little-leaf linden (<i>Tilia cordata</i>)	City owned	48.7	4.9	1.5	>3	Fair; mature; co-dominant stems 3.5m – roughly equal in diameter and mildly divergent; introduced species; to be preserved and protected

Table 1. Cont.

Tree No.	Tree species	Owner-ship ¹	DBH ² (cm)	CRZ ³	SRZ ⁴	Distance to excavation ⁵	Tree Condition; Age Class; Condition Notes; Species Origin & Preservation Status (to be removed or preserved and protected)
20	Little-leaf linden (<i>Tilia cordata</i>)	City owned	19 avg.	1.9	0.6	>5	Poor; mature; five stemmed from grade – coppice growth; all strongly upright (epicormic); crown asymmetric towards east and south due to influence of tree #19; introduced species; to be preserved and protected
21	Sugar maple (<i>Acer saccharum</i>)	City owned	41.4	4.1	1.2	>5	Fair; mature; generally upright form; central stem with co-dominant leaders at 5m with inclusion ridge at union; native species; to be preserved and protected
22	Little-leaf linden (<i>Tilia cordata</i>)	City owned	43.8	4.4	1.3	>5	Good; mature; central upright stem with suppressed laterals starting at 1.5m; dieback near crown apex; introduced species; to be preserved and protected
23	Catalpa (<i>Catalpa speciosa</i>)	City owned	23.7	2.4	0.7	>5	Good; maturing; strongly upright form – central stem with suppressed lateral at 1.5m on east; introduced species; to be preserved and protected
24	Norway maple (<i>Acer platanoides</i>)	City owned	45.6	4.6	1.4	>7	Fair; mature; co-dominant stems 1.5m – central stem with competing lateral on southeast; very weak primary union; broad, generally symmetric crown; introduced invasive species; to be preserved and protected
25	Little-leaf linden (<i>Tilia cordata</i>)	City owned	61.3	6.1	1.8	>7	Fair; mature; poor form – four stemmed at 2m (two dominant and two suppressed on north); dominant stems both bisect at 3.5-4m; broad, moderately asymmetric crown; introduced species; to be preserved and protected
26	Manitoba maple (<i>Acer negundo</i>)	City owned	67.8 (at 0.5m)	6.8	2.0	>5	Poor; mature; central stem with competing lateral at 1.2m on east; central stem bisects at 3.25m; very broad crown; naturalized species; to be preserved and protected

Table 1. Cont.

Tree No.	Tree species	Ownership ¹	DBH ² (cm)	CRZ ³	SRZ ⁴	Distance to excavation ⁵	Tree Condition; Age Class; Condition Notes; Species Origin & Preservation Status (to be removed or preserved and protected)
27	Bur oak (<i>Quercus macrocarpa</i>)	City owned	23.4	2.3	0.7	>7	Fair; maturing; heavily suppressed by tree #26; central stem with multiple competing and suppressed laterals on south - crown heavily asymmetric; native species; to be preserved and protected
28	White pine (<i>Pinus strobus</i>)	Private onsite	57	-	-	-	Fair; mature; dominant central stem with moderately asymmetric crown towards south; fair crown density, growth increment and needle colour; tagged #631; native species; to be removed (conflicts with construction)
29	White pine (<i>Pinus strobus</i>)	Private onsite	69	-	-	-	Fair; mature; dominant central stem with generally symmetric crown; fair crown density, growth increment and needle colour; tagged #630; native species; to be removed (conflicts with construction)
30	Siberian elm (<i>Ulmus pumila</i>),	Neighbour & co-owned	+/-50 avg.	+/-5	+/-1.5	3	Fair; mature; line of trees likely originally planted as a hedge – now full-sized trees; introduced invasive species; to be preserved and protected
31	Siberian elm (<i>Ulmus pumila</i>) Manitoba maple (<i>Acer negundo</i>) & White elm (<i>Ulmus americana</i>)	Neighbour & co-owned with school yard	+/-10 to +/-40	+/-4	+/-1.2	3	Fair; maturing; line of trees likely originally from seed spread from nearby mature trees in 30; one naturalized Manitoba maple and one native elm present – both likely from seed as well; introduced invasive species; to be preserved and protected

Table 1. Cont.

Tree No.	Tree species	Ownership ¹	DBH ² (cm)	CRZ ³	SRZ ⁴	Distance to excavation ⁵	Tree Condition; Age Class; Condition Notes; Species Origin & Preservation Status (to be removed or preserved and protected)
32	Siberian elm <i>(Ulmus pumila)</i>	Neighbour & co-owned	+/-10 to +/-30	+/-3	+/-0.9	3	Fair; maturing; line of trees likely originally from seed spread from nearby mature trees in 30; introduced invasive species; to be preserved and protected

¹As determine from topographic survey prepared by Annis O’Sullivan Vollebakk Ltd.; ²Diameter at breast height, or 1.3m from grade (unless otherwise indicated); ³Critical root zone (CRZ) is 10 centimetres from the trunk of a tree for every centimetre of DBH. The CRZ is calculated as DBH x 10 cm; ⁴Static root zone (SRZ) is considered three times the DBH and is considered the zone in which no roots can be cut. ⁵Distance to excavation approximate only.

GENERAL NOTES

LEGEND

- DECIDUOUS TREE TO REMAIN
- TREES TO BE RETAINED
- CRITICAL ROOT ZONE
- PROTECTIVE FENCING
- DECIDUOUS TREE TO BE REMOVED
- ✱ CONIFEROUS TREE TO BE REMOVED
- CRITICAL ROOT ZONE

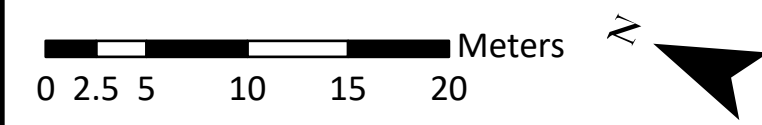
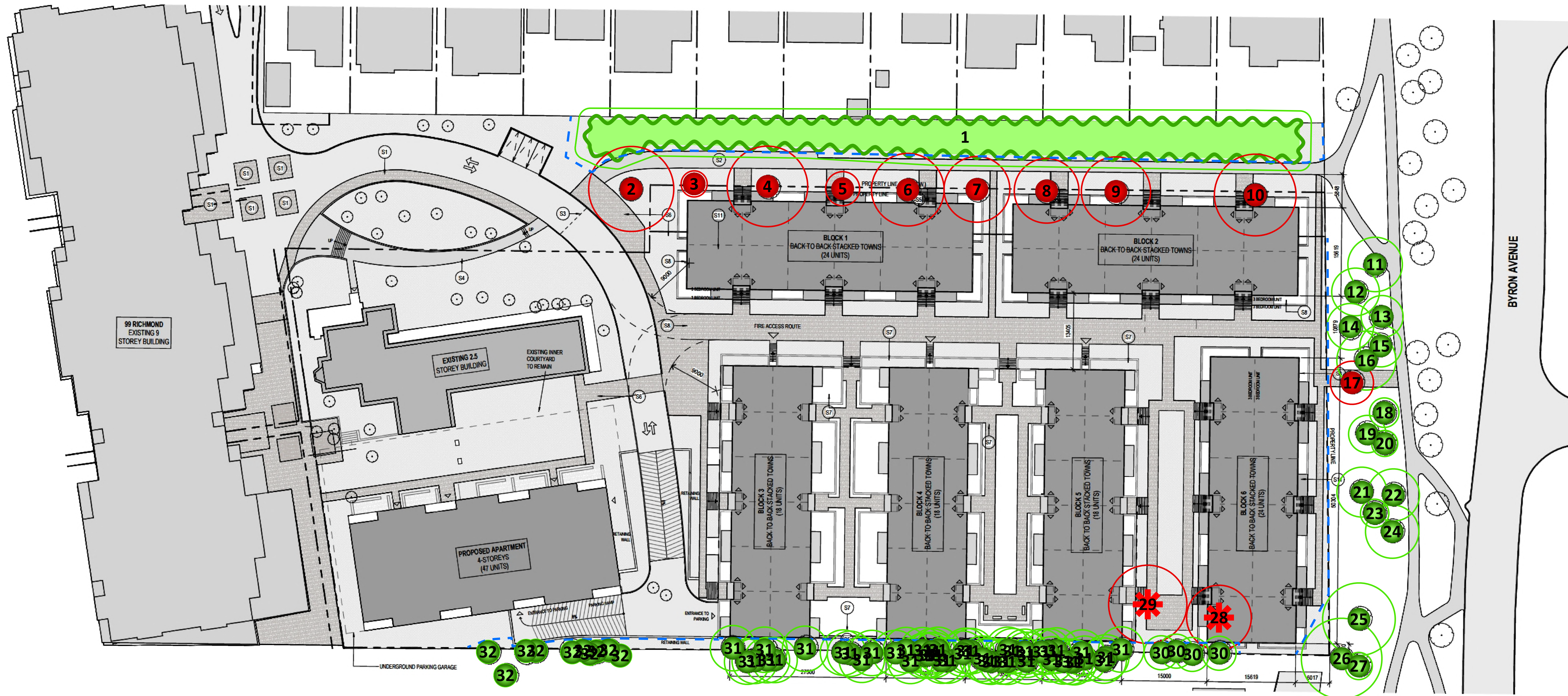

DRAWING: Tree Conservation Plan

PROJECT: 114 RICHMOND ROAD
CITY OF OTTAWA



Andrew K. Boyd, R.P.F.

SCALE: 1:375
DATE: 2026-03-09
DRAWN BY: SS
SHEET NO: 1

1 1 4 R

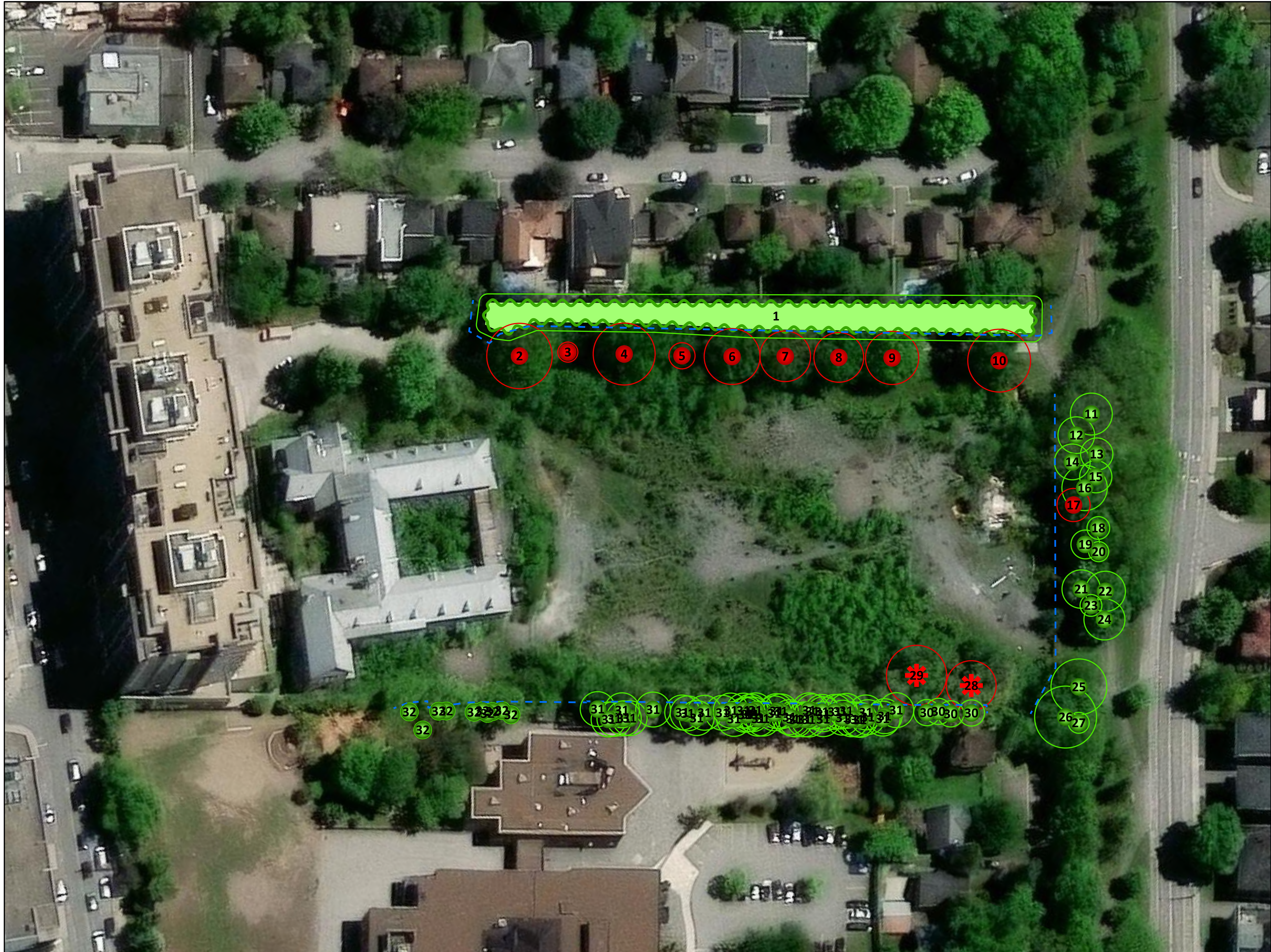

GENERAL NOTES

Microsoft, Vantor

LEGEND

- DECIDUOUS TREE TO REMAIN
- TREES TO BE RETAINED
- CRITICAL ROOT ZONE
- PROTECTIVE FENCING
- DECIDUOUS TREE TO BE REMOVED
- ★ CONIFEROUS TREE TO BE REMOVED
- CRITICAL ROOT ZONE



DRAWING: Tree Conservation Plan

PROJECT: 114 RICHMOND ROAD
CITY OF OTTAWA



Andrew K. Boyd, R.P.F.

SCALE: 1:375	1 1 4 R
DATE: 2026-03-09	
DRAWN BY: SS	
SHEET NO: 1	

Pictures 1 through 6 on pages 13 to 18 of this report show selected trees and tree groupings on and adjacent to the subject property.

FEDERAL AND PROVINCIAL REGULATIONS

Federal and provincial regulations can be applicable to trees on private property. In particular, the following two regulations have been considered for this property:

- 1) Endangered Species Act (2007): The Province of Ontario's Endangered Species Act (2007) mandates tree species on the Species at Risk in Ontario (SARO) list be identified. Butternut (*Juglans cinerea*) and black ash (*Fraxinus nigra*) are present in Eastern Ontario and are listed as threatened on the SARO. Because of this they are protected from harm. No trees of this species were identified on the subject or nearby properties.
- 2) Migratory Bird Convention Act (1994): In the period between mid-April and August of each year nest surveys are required to be performed by a suitably trained person no more than three (3) days before trees or other similar nesting habitat are to be removed.

TREE PRESERVATION AND PROTECTION MEASURES

Preservation and protection measures intended to mitigate damage during construction will be applied for the trees to be retained on and adjacent to the subject property. The following measures are the minimum required by the City of Ottawa to ensure tree survival during and following construction:

1. As per the City of Ottawa's tree protection barrier specification, erect a fence as close as possible to the CRZ of the tree(s) (see page 11 for City of Ottawa tree protection barrier specifications).
2. Do not place any material or equipment within the CRZ of the tree(s).
3. Do not attach any signs, notices or posters to any tree.
4. Do not raise or lower the existing grade within the CRZ without approval.
5. Tunnel or bore instead of trenching within the CRZ of any tree.
6. Do not damage the root system, trunk or branches of any tree.
7. Ensure that exhaust fumes from all equipment are NOT directed towards any tree's canopy.

TREE PRESERVATION MEASURES

As excavation will be within the CRZs and SRZs of multiple adjacent trees, the following measures will be taken:

1. Air or hydro excavation along the edge of excavation to carefully expose roots. Exposed roots will then be cleanly cut and sealed before being reburied (see City of Ottawa root pruning detail on page 12). Excavation can then resume using traditional mechanical means. Sealing the cleanly cut root ends with a beeswax product will help prevent the loss of moisture and facilitate healing.

2. An arborist and a City forestry inspector will be present during the excavation and root pruning to assess the stability and viability of retained trees. If any trees are thought to be terminally impacted by root loss, the neighbouring property owners will be alerted and their permission to remove them will be sought.
3. If the excavation is to be left open for any length of time a covering of at least three layers of moistened burlap is to be draped over the exposed face of excavation closet to the tree. A final covering of clear plastic or white tarp will help retain moisture within the burlap. The use of burlap and coverings will help reduce the loss of moisture from the soil surrounding the remaining roots.

Please do not hesitate to contact the undersigned with any questions concerning this report.

This report is subject to the attached Limitations of Tree Assessments and Liability to which the reader's attention is directed.

Yours,



Andrew K. Boyd, B.Sc.F, R.P.F. (#1828)
Certified Arborist #ON-0496A
Consulting Urban Forester

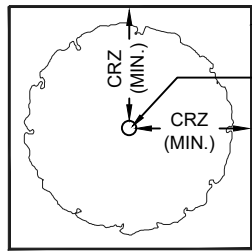

TREE PROTECTION FENCING
TREE TRUNK

PLAN VIEW

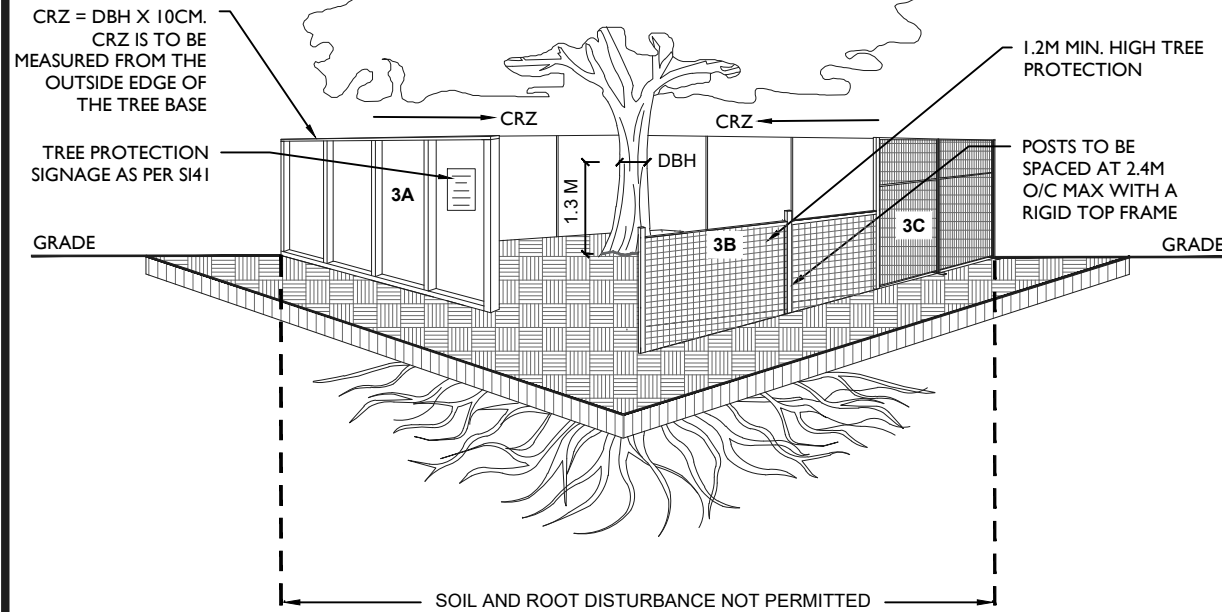

TREE PROTECTION REQUIREMENTS:

1. TREE PROTECTION FENCING MUST BE INSTALLED PER THE TREE CONSERVATION REPORT (TCR) OR THE TREE INFORMATION REPORT (TIR), WHICH EVER APPLIES, AND MUST BE DETERMINED BY AN ARBORIST AND APPROVED BY CITY FORESTRY STAFF PRIOR TO THE COMMENCEMENT OF THE WORK AND REMAIN IN PLACE UNTIL THE WORK IS COMPLETE.
 2. FOR WORK WITHIN THE TREE PROTECTION ZONE (TPZ):
 - DO NOT PLACE OR STORE ANY MATERIAL, FILL OR EQUIPMENT (INCLUDING OUTHOUSES)
 - DO NOT ATTACH ANY SIGNS, NOTICES OR POSTERS TO ANY TREE.
 - DO NOT RAISE OR LOWER THE EXISTING GRADE (SCRAPING OF THE TOP LAYER OF SOIL FOR FINAL GRADING MUST BE AVOIDED WITHIN THE CRZ, THIS INCLUDES FINAL LANDSCAPE/ REINSTATEMENT GRADING).
 - ENSURE THAT EXHAUST FUMES FROM ALL EQUIPMENT ARE DIRECTED AWAY FROM THE TREE CANOPY
 - DO NOT EXTEND/REINSTATE HARD SURFACE WITHIN THE CRZ
 - DO NOT DISPOSE OF WASTE OR VOLATILE MATERIALS, SUCH AS MINERAL SPIRITS, OIL OR PAINT THINNER
 - DO NOT OPERATE, PARK, REPAIR, OR REFUEL VEHICLES OR EQUIPMENT.
 - DO NOT DAMAGE THE ROOT SYSTEM, TRUNK OR BRANCHES OF ANY TREE
 - EXCAVATION SHALL BE CARRIED OUT BY TUNNELING, BORING OR HYDRO VAC
 3. TREE PROTECTION FENCING MUST BE AT LEAST 1.2M IN HEIGHT AND BE CONSTRUCTED OF RIGID OR FRAMED MATERIALS SUCH AS:
 - A. PLYWOOD HOARDING
 - B. SNOW FENCE
 - C. MODULAR STEEL PANELS
- INSTALLATION OF ALL FENCING TYPES, A, B OR C, MUST MINIMIZE DAMAGE TO EXISTING ROOTS.
4. ANY DEVIATION TO THE APPROVED TREE PROTECTION FENCING LOCATION MUST BE SUPERVISED BY AN ARBORIST AND APPROVED BY CITY FORESTRY STAFF. MODIFICATIONS MAY INCLUDE THE INSTALLATION OF PLYWOOD, WOOD CHIPS, OR STEEL PLATING OVER THE ROOTS, OR PERFORMING PROPER ROOT PRUNING AND CARE WHERE ROOTS ARE ENCOUNTERED.
 5. IF TREES ARE BEING AFFECTED BY CONSTRUCTION, A WATER AND FERTILIZING PROGRAM MAY BE REQUIRED.
 6. THE CITY OF OTTAWA'S TREE PROTECTION BY-LAW (NO. 2020-340) AND STANDARD F-8011 APPLY



Tree Protection

SCALE: NTS

DATE: JANUARY 2026

DRAWING NO.: F7

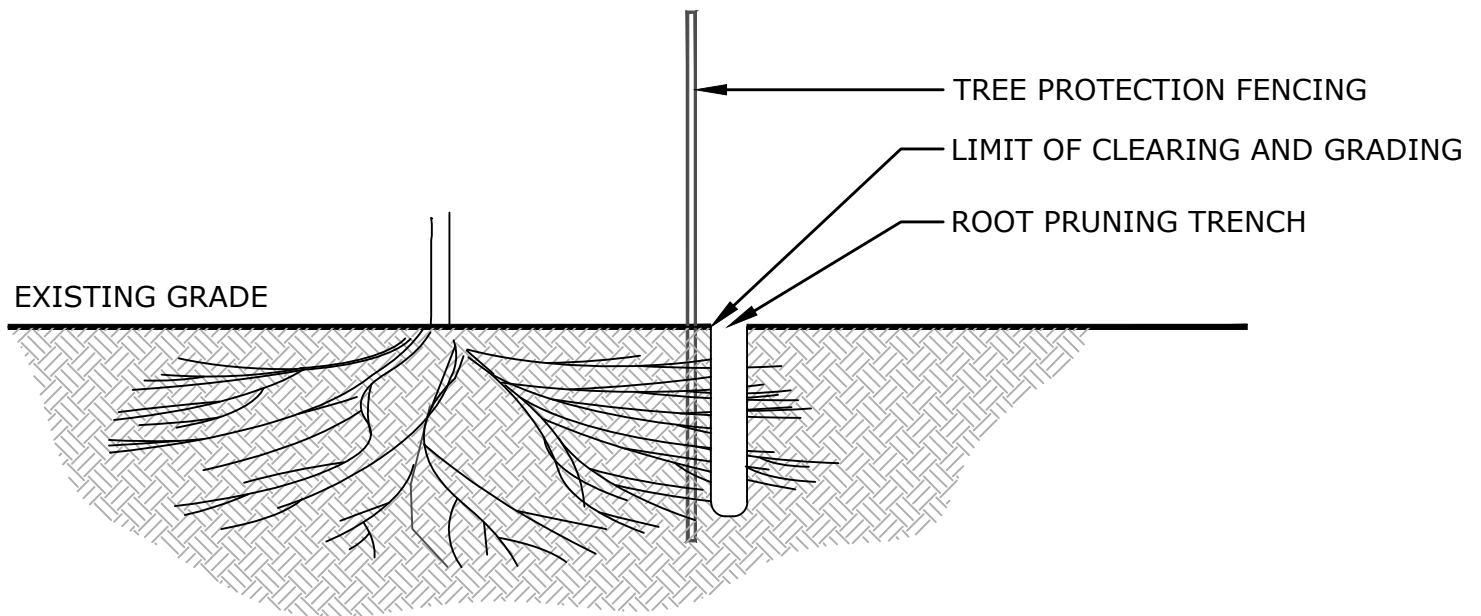

NOTES:

1. PROPER ROOT PRUNING TECHNIQUES REQUIRED WHEN TREE ROOTS ARE ENCOUNTERED DURING EXCAVATION.
2. EXCAVATION (ROOT PRUNING TRENCH) SHALL BE CARRIED OUT BY TUNNELING, BORING OR HYDRO VAC.
3. ROOTS ARE TO BE CLEANLY CUT AND THE AREA AROUND THE ROOTS SHALL BE BACKFILLED WITH SUITABLE MATERIAL, AS DETAILED IN THE CONTRACT DRAWINGS.
4. TREES SHALL BE PRUNED TO RESTORE TREE APPEARANCE AND/OR RESTORE THE BALANCE BETWEEN TOP GROWTH AND ROOTS.
5. LEADERS SHALL NOT BE PRUNED.



Picture 1. Tree grouping #1 (left) cedars and spruce trees on city property and line of maples shared with city at 114 Richmond Road



Picture 2. Maple tree #2 shared with city at 114 Richmond Road



Picture 3. City trees # adjacent to 114 Richmond Road



Picture 4. City trees #25 (background), #26 (left) and #27 adjacent to 114 Richmond Road





Picture 5. Tree #28 (white pine on right) and tree line #30 (Siberian elms on left) located on and adjacent to 114 Richmond Road



Picture 6. Tree line #31 (in background) located adjacent to 114 Richmond Road

LIMITATIONS OF TREE ASSESSMENTS & LIABILITY

GENERAL

It is the policy of *IFS Associates Inc.* to attach the following clause regarding limitations. We do this to ensure that our clients are clearly aware of what is technically and professionally realistic in assessing trees for retention.

This report was carried out by *IFS Associates Inc.* at the request of the client. The information, interpretation and analysis expressed in this report are for the sole benefit and exclusive use of the client. Possession of this report or a copy thereof does not imply right of publication or use for any purpose by any other than the client to whom it is addressed. Unless otherwise required by law, neither all or any part of the contents of this report, nor copy thereof, shall be conveyed by anyone, including the client, to the public through public relations, news or other media, without the prior expressly written consent of the author, and especially as to value conclusions, identity of the author, or any reference to any professional society or institute or to any initialed designation conferred upon the author as stated in his qualifications.

This report and any values expressed herein represent the opinion of the author; his fee is in no way contingent upon the reporting of a specified value, a stipulated result, nor upon any finding to be reported. Details obtained from photographs, sketches, *etc.*, are intended as visual aids and are not to scale. They should not be construed as engineering reports or surveys. Although every effort has been made to ensure that this assessment is reasonably accurate, the tree(s) should be reassessed at least annually. The assessment presented in this report is valid at the time of the inspection only. The loss or alteration of any part of this report invalidates the entire report.

LIMITATIONS

The information contained in this report covers only the tree(s) in question and no others. It reflects the condition of the assessed tree(s) at the time of inspection and was limited to a visual examination of the accessible portions only. *IFS Associates Inc.* has prepared this report in a manner consistent with that level of care and skill ordinarily exercised by members of the forestry and arboricultural professions, subject to the time limits and physical constraints applicable to this report. The assessment of the tree(s) presented in this report has been made using accepted arboricultural techniques. These include a visual examination of the above-ground portions of each tree for structural defects, scars, cracks, cavities, external indications of decay such as fungal fruiting bodies, evidence of insect infestations, discoloured foliage, the condition of any visible root structures, the degree and direction of lean (if any), the general condition of the tree(s) and the surrounding site, and the proximity of people and property. Except where specifically noted in the report, the tree(s) examined were not dissected, cored, probed or climbed to gain further evidence of their structural condition. Also, unless otherwise noted, no detailed root collar examinations involving excavation were undertaken.

While reasonable efforts have been made to ensure that the tree(s) proposed for retention are healthy, no warranty or guarantee, expressed or implied, are offered that these trees, or any parts of them, will remain standing. This includes other trees on or off the property not examined as part of this assignment. It is both professionally and practically impossible to predict with absolute certainty the behaviour of any single tree or groups of trees or their component parts in all circumstances, especially when within construction zones. Inevitably, a standing tree will always pose some risk. Most trees have the potential for failure in the event of root loss due to excavation and other construction-related impacts. This risk can only be eliminated through full tree removal.

Notwithstanding the recommendations and conclusions made in this report, it must be realized that trees are living organisms, and their health and vigour constantly change over time. They are not immune to changes in site conditions, or seasonal variations in the weather. It is a condition of this report that *IFS Associates Inc.* be notified of any changes in tree condition and be provided an opportunity to review or revise the recommendations within this report. Recognition of changes to a tree's condition requires expertise and extensive experience. It is recommended that *IFS Associates Inc.* be employed to re-inspect the tree(s) with sufficient frequency to detect if conditions have changed significantly.

ASSUMPTIONS

Statements made to *IFS Associates Inc.* in regards to the condition, history and location of the tree(s) are assumed to be correct. Unless indicated otherwise, all trees under investigation in this report are assumed to be on the client's property. A recent survey prepared by a Licensed Ontario Land Surveyor showing all relevant trees, both on and adjacent to the subject property, will be provided prior to the start of field work. The final version of the grading plan for the project will be provided prior to completion of the report. Any further changes to this plan invalidate the report on which it is based. *IFS Associates Inc.* must be provided the opportunity to revise the report in relation to any significant changes to the grading plan. The procurement of said survey and grading plan, and the costs associated with them both, are the responsibility of the client, not *IFS Associates Inc.*

LIABILITY

Without limiting the foregoing, no liability is assumed by *IFS Associates Inc.* for: 1) any legal description provided with respect to the property; 2) issues of title and/or ownership with respect to the property; 3) the accuracy of the property line locations or boundaries with respect to the property; 4) the accuracy of any other information provided by the client or third parties; 5) any consequential loss, injury or damages suffered by the client or any third parties, including but not limited to replacement costs, loss of use, earnings and business interruption; and, 6) the unauthorized distribution of the report.

INDEMNIFICATION

An applicant for a permit or other approval based on this report shall agree to indemnify and save harmless *IFS Associates Inc.* from any and all claims, demands, causes of action, losses, costs or damages that affected private landowners and/or the City of Ottawa may suffer, incur or be liable for resulting from the issuance of a permit or approval based on this report or from the performance or non-performance of the applicant, whether with or without negligence on the part of the applicant, or the applicant's employees, directors, contractors and agents.

Further, under no circumstances may any claims be initiated or commenced by the applicant against *IFS Associates Inc.* or any of its directors, officers, employees, contractors, agents or assessors, in contract or in tort, more than 12 months after the date of this report.

ONGOING SERVICES

IFS Associates Inc. accepts no responsibility for the implementation of any or all parts of the report, unless specifically requested to supervise the implementation or examine the results of activities recommended herein. In the event that examination or supervision is requested, that request shall be made in writing and the details, including fees, agreed to in advance.