

6259 RENAUD ROAD,
OTTAWA, ONTARIO

PRELIMINARY CONSTRUCTION MANAGEMENT PLAN

Presented to:

Mr. Jaafar Oleiche
Project Manager – Land Development
Richcraft Homes Ltd.
2280 St. Laurent Boulevard, Suite 201
Ottawa, Ontario
K1G 4K1

June 10, 2025



Project 7369

CASTLEGLENN CONSULTANTS LTD.

THIRD PARTY DISCLAIMER

This study has been prepared by Castleglenn Consultants Inc. (“CGI”) for the benefit of the Client to whom it is addressed. The information and data contained herein represents CGI’s best professional judgment in light of the knowledge and information available to CGI at the time of preparation. Except as required by law, this study and the information and data contained herein are to be treated as confidential and may be used and relied upon only by the Client, its officers and employees. CGI denies any liability whatsoever to other parties who may obtain access to this study for any injury, loss or damage suffered by such parties arising from their use of, or reliance upon, this study or any of its contents without the express written consent of CGI and the Client.

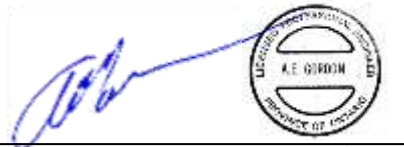

Mr. Arthur Gordon B.A. P.Eng
Principal Engineer
Castleglenn Consultants Inc.
Authorized representative of the Applicant:
Richcraft Homes



Mr. Konstantin Joulanov B.Asc
Transportation Planner
Castleglenn Consultants Inc.

Introduction

This Preliminary Construction Management Plan (CMP) is intended to address the City of Ottawa’s requirements under Bylaw 2003-445 to identify impacts to all modes of transportation and all elements in the public right of way during the anticipated construction of the proposed 6259 Renaud Road development in the City of Ottawa. The CMP is required before site plan approval and prior to issuance of a building permit.

Figure 1 illustrates the boundaries of the site, which is bounded by Renaud Road on the south, Compass Street on the east, Melodie Street to the west and a public walking path with green space to the North.



Figure 1: Location of 6259 Renaud Road

The Proposed Development

Figure 2 illustrates 7 residential townhouse blocks resulting in a total of 76 units that would be municipally serviced.

- 48 of the units would be accessed by internal subdivision roadways,
- 16 of the units would have driveway access directly onto/from Renaud Road,
- 6 of the units would have driveway access directly onto/from Compass Street,
- 6 of the units would have driveway access directly onto/from Melodie Steet.

The subdivision is characterized by an internal driveway with two connection points onto, from Renaud Road. There is an amenity area on the southeast corner of the site as well as a landscape feature with walking pathways connecting the public path to the north with the Renaud Road Pedestrian Crossing (PXO) to the south of the property. The proposed townhouse blocks will be surrounded by landscaped areas, asphalt paved access lanes, parking areas, and sidewalks.

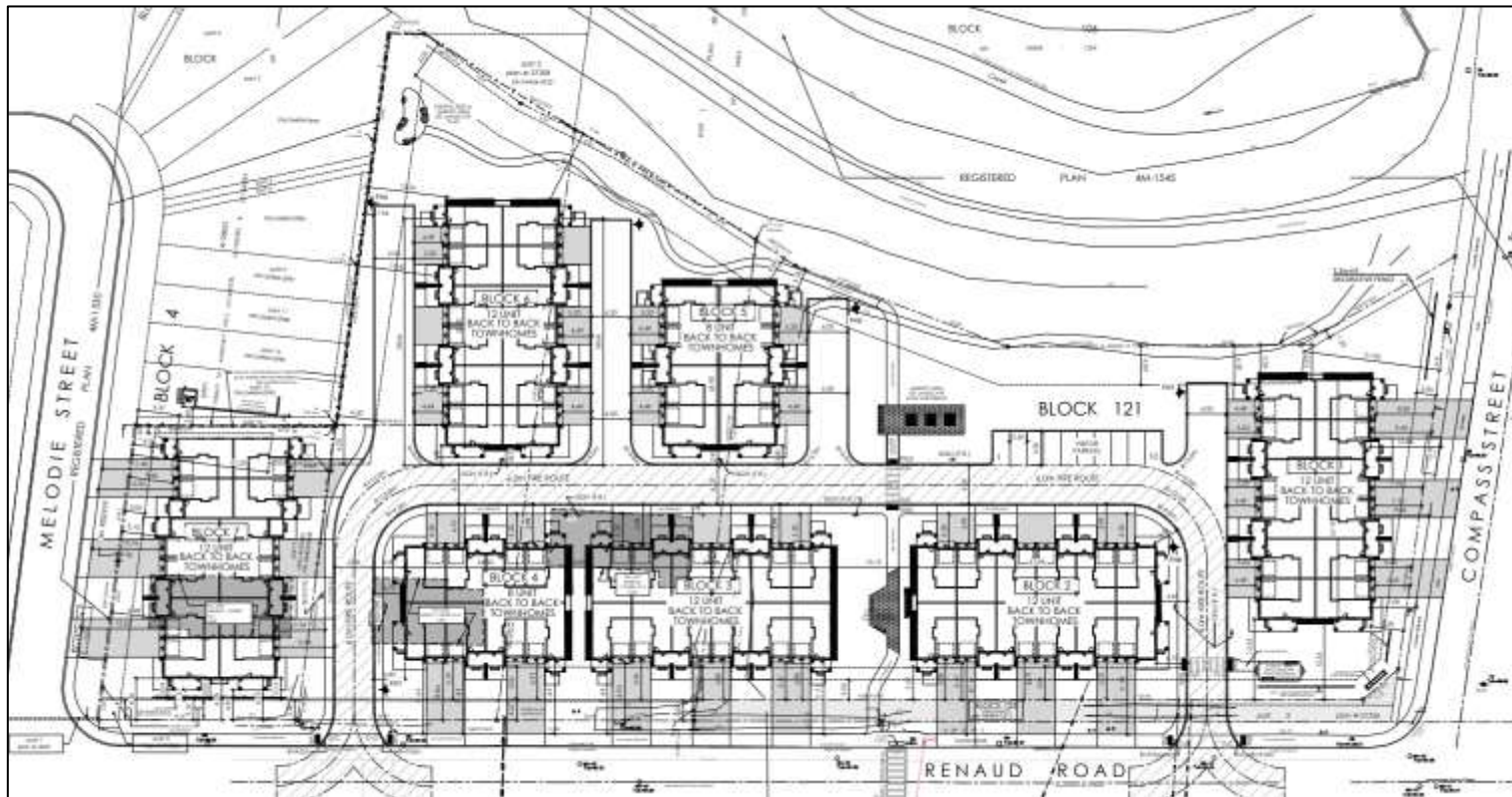

Figure 2: Extract of Site Plan: 6259 Renaud Road

Application Submission 1: Diagram

Storage of Equipment and Supplies: Figure 2 above illustrates the proposed 6259 Renaud Road site plan. All construction related materials will be securely stored within the site limits. It's emphasized that the actual location on the site should be considered dynamic in that it may be moved as necessary to available areas as construction proceeds. The visitor parking and landscape structure areas would be most conducive for storage purposes. All large construction related material (such as lumber, framing materials, steel, roofing materials, masonry supplies, concrete blocks, stones and pavers etc.) would be off-loaded and securely stored on-site. The site is large enough to support construction staging and staff parking on-site. On-street parking will be avoided wherever possible.

Servicing Impacts to the Public Right-of Way: Figure 3 below displays an extract of the proposed servicing plan which illustrates the stormwater (green lines), sanitary (red lines) and water (blue lines) connections that would connect the construction site to existing municipal services.

All three services (sanitary, storm and water) enter the site from Compass Street on the east side of the property at various points. Additionally, there is a second watermain feed that would enter at the western access onto Renaud Road to complete the watermain loop.

The storm service connection would take place just to the west of the Compass Street centerline. The sanitary connection is nearest the crown/centerline of Compass Street. The watermain connections are illustrated as being located on the east side of Compass Street and south side of Renaud Road.

The public right-of-way that would be required for construction purposes is indicated within Figure 3 below:

Compass Street:

Each connection to municipal services will be short in duration and likely involve a single lane of Compass Street to be closed to traffic during this construction and roadway reinstatement. Road cuts along Compass Street would be completed one at a time, with a single lane closure that will progressively move to the south as each service connection is made. All required servicing connections will be coordinated within these staged closures. We do not anticipate the need to restrict closures to weekends only.

- The only connection that would impact the northbound lanes of Compass Street was thought to be the water connection. Construction should be done in two stages, such that only one lane of traffic needs to be closed at any time.
- OC Transpo Bus Route 24 from St-Laurent Station to Chapel Hill runs along Renaud Road and Compass Street. This only occurs on weekdays and could be avoided by doing construction on the weekend.
- There are no bike lanes on Compass Street that would be impacted by construction activities.

Renaud Road:

- The second connection from the development to the watermain cuts across all of Renaud Road. Construction should be done in two stages, such that only one lane of traffic needs to be closed at any time.
- OC Transpo Bus Route 32 from Blair to Chapel Hill runs along Renaud Road.
- The westbound bike lane on the north side of Renaud Road would be required to be closed temporarily during construction activities. Cyclist would need to share the westbound vehicle lane.

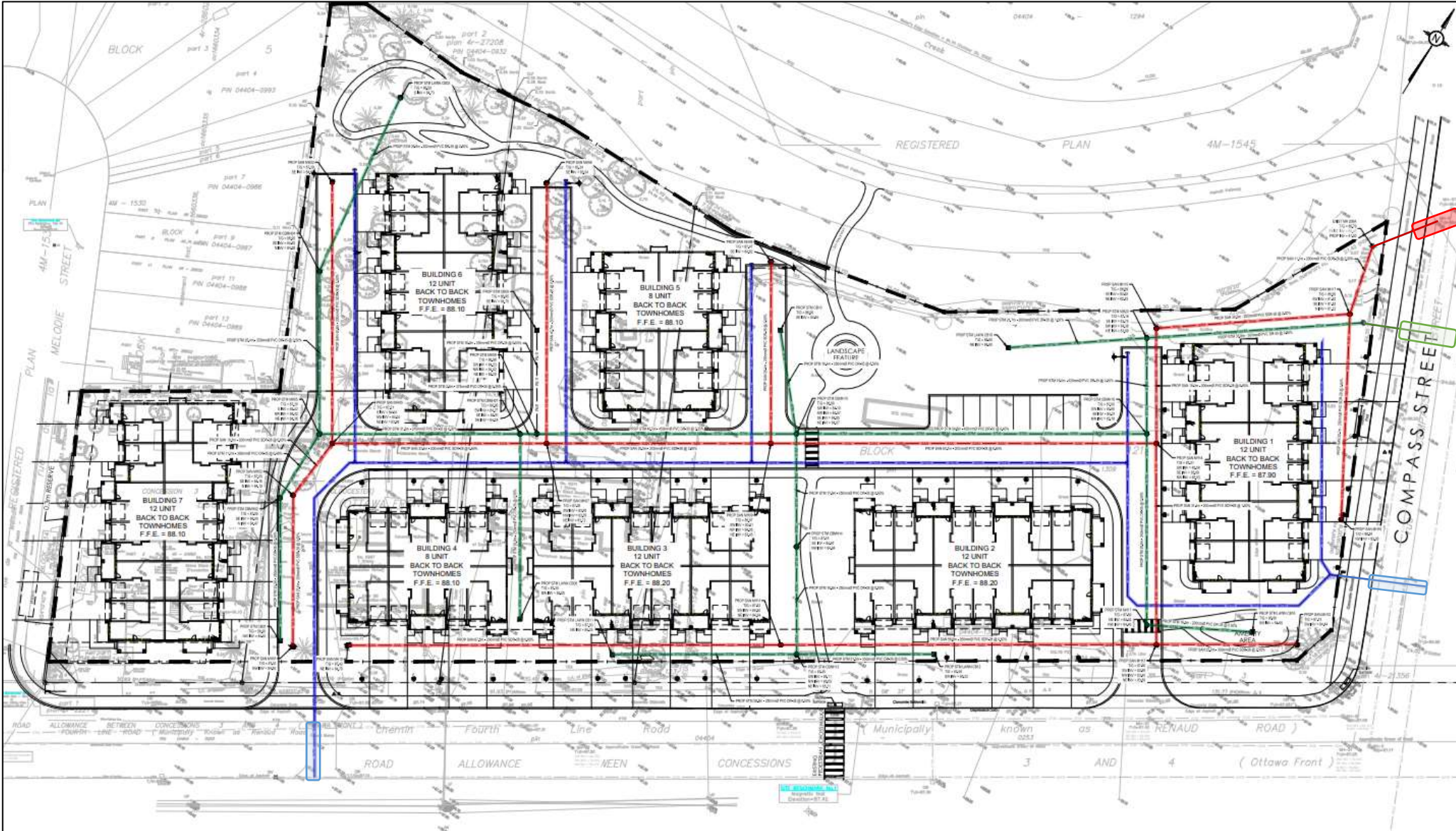

Figure 3: Extract of Servicing Plan

Application Submission 2: Check-List

- o *Traffic Control Plan:* Prior to the commencement of construction, a traffic control plan would be prepared ready for implementation and put into effect as servicing connections are established and the roadworks reinstated. All necessary encroachments on municipal rights-of-way will be coordinated with City of Ottawa staff (By-law Services).
- o *Planned Pedestrian Detour:* The existing sidewalk along the west side of Compass Avenue and north side of Renaud Road would be closed in the vicinity of the planned servicing connections. Pedestrian traffic would be detoured to the existing sidewalk on the opposite side of each of the roadways while the servicing connections are established, and reinstatement of roadworks takes place.
 - o The sidewalk and PXO on the north side of Renaud will also require closure (exact time of closure TBD). Pedestrian access will be safely redirected to Compass Street, which offers a suitable alternative crossing route.
 - o The existing sidewalks will be ripped out completely and redone.
- o *Temporary Fencing:* It is understood that temporary fencing across the entrance to site will be required and along any open holes or areas of excavation and where any temporary barrier may be required to accommodate health and safety requirements and secure construction materials.
- o *Roadway Surface Maintenance:* The private accesses into the property are to be stabilized with aggregate and if warranted install mud mats to prevent construction vehicles from tracking mud/debris/dirt onto Renaud Road that could create a hazard to motorists and pedestrians. The contractor is responsible for keeping public roads free and clean from mud and debris.
- o *Anticipated Ingress/Egress:* Attachment “A” illustrates the turning movements associated with a fire truck and a waste collection truck. This would also simulate a construction vehicle entering and leaving the proposed construction site. The most likely route taken to approach the site would be by way of Navan Road onto Renaud Road from the west and Mer Bleue Road, onto Brian Coburn Boulevard, to Fern Casey onto Renaud Road from the east.

Safety Measures:

- Richcraft’s Construction Managers will be responsible for providing, upon request from the City, Richcraft’s safety manual and policy in addition to a site-specific safety plan for the 6259 Renaud Road project.
- Richcraft will perform regular safety inspections to ensure that all contractors are following safety policies, procedures, and regulations.

Key Contacts:

- Owner: Richcraft Homes
- Project Management Firm: Richcraft Homes
- Construction Management Firm: Richcraft Homes
- Emergency Contact: A specific contact name and number will be provided closer to site mobilization.



ATTACHMENT “A” TURNING MOVEMENT DIAGRAMS

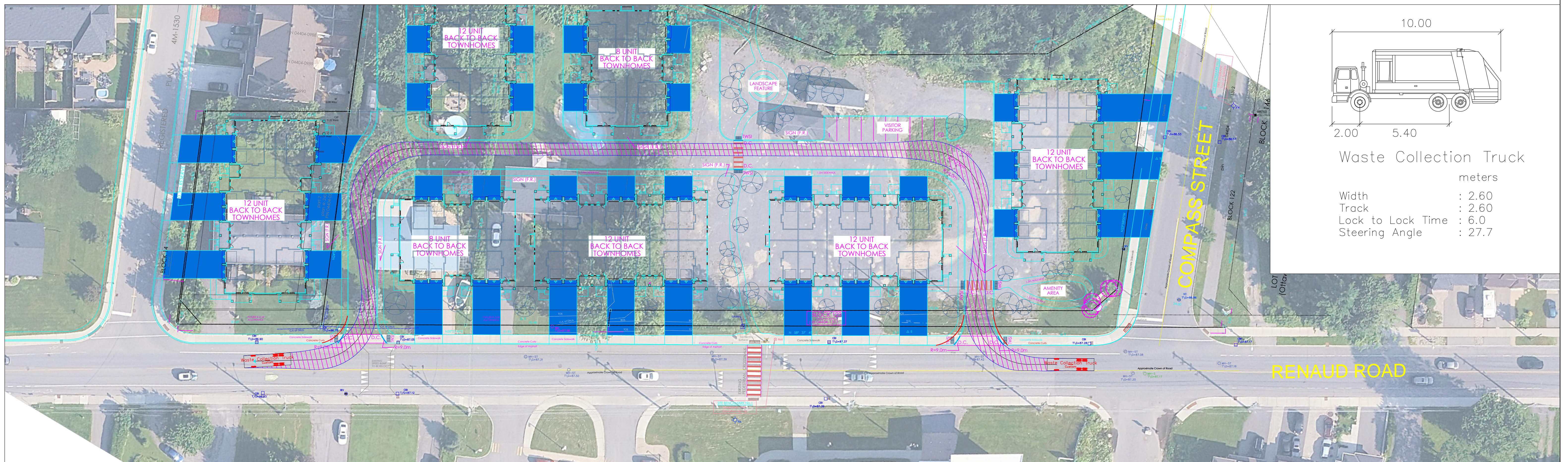
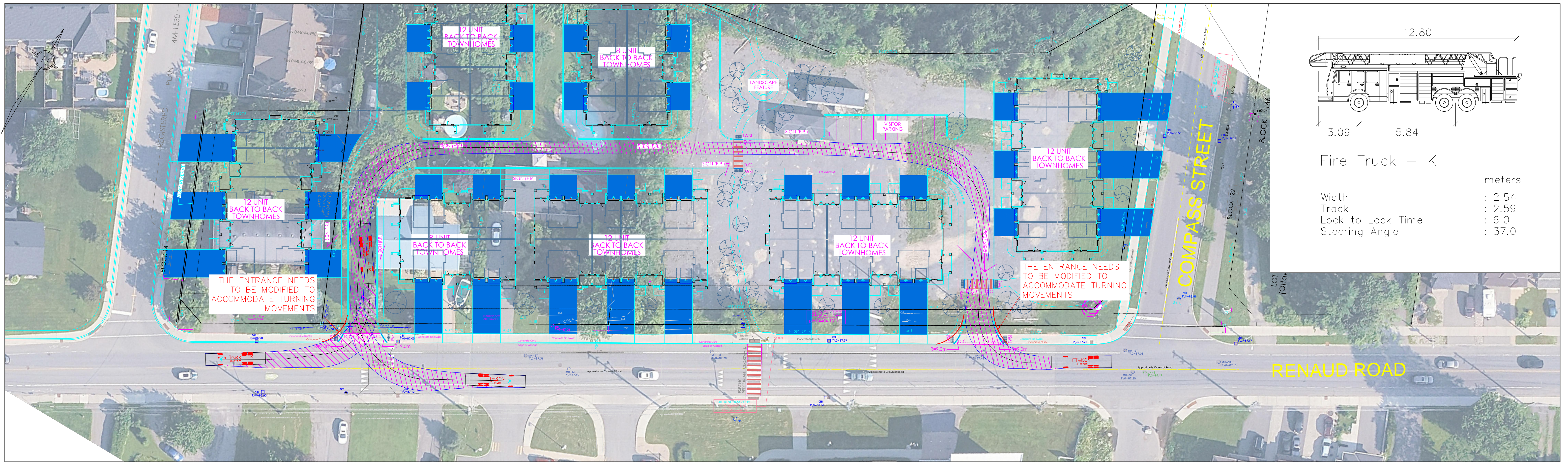

CONSULTANT



Castleglenn Consultants
Engineers, Project Managers & Planners

DESIGNED BY A.P. CHECKED BY
CONSULTANTS JOB NO.

CONCEPT PLAN
FOR DISCUSSION ONLY

FIRE TRUCK/WASTE COLLECTION TRUCK COMING FROM EAST

8.0m 0 8.0m
HORIZ 1: 400

SCALE

PLAN NUMBER

BLOCK 121		
TRAILSEDGE PHASE3		
STATUS DRAFT	DATE 02-04-2025	SHEET 01 OF 02

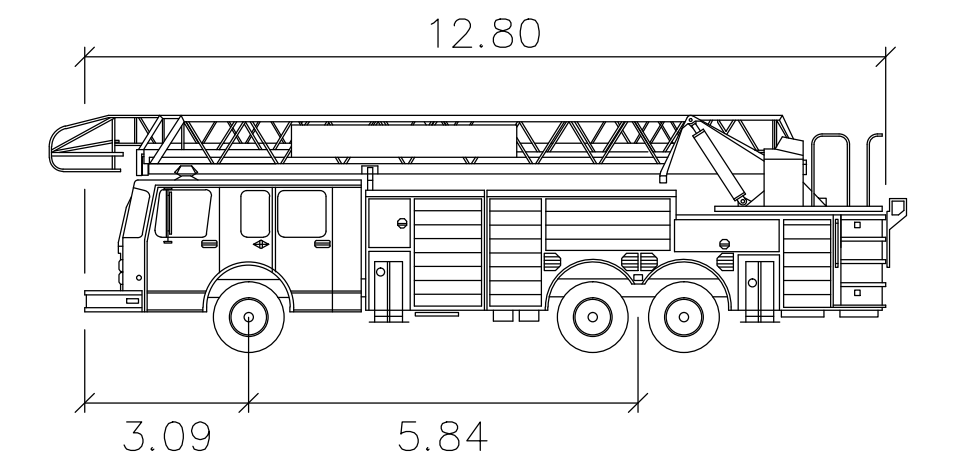
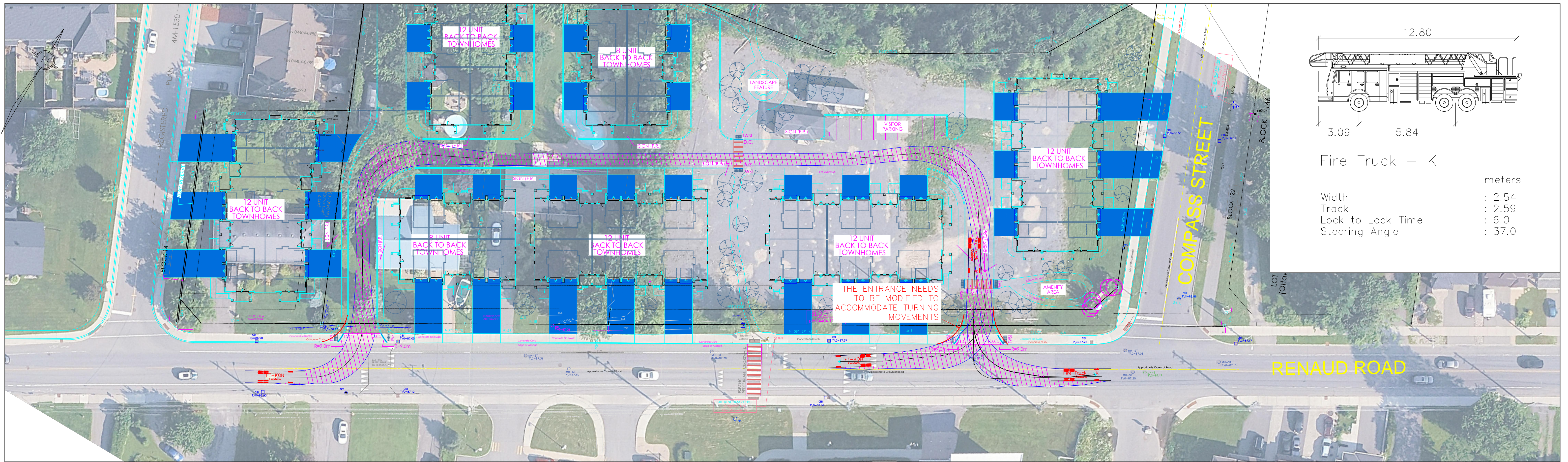

Fire Truck – K

	meters
Width	: 2.54
Track	: 2.59
Lock to Lock Time	: 6.0
Steering Angle	: 37.0

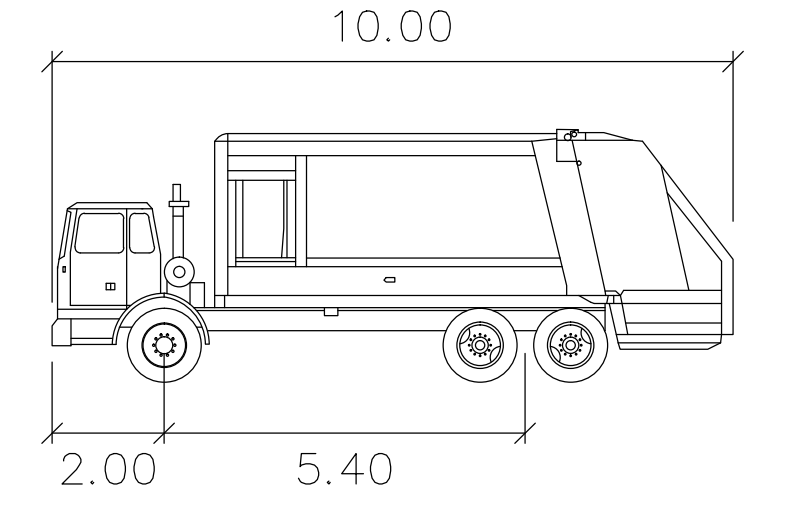
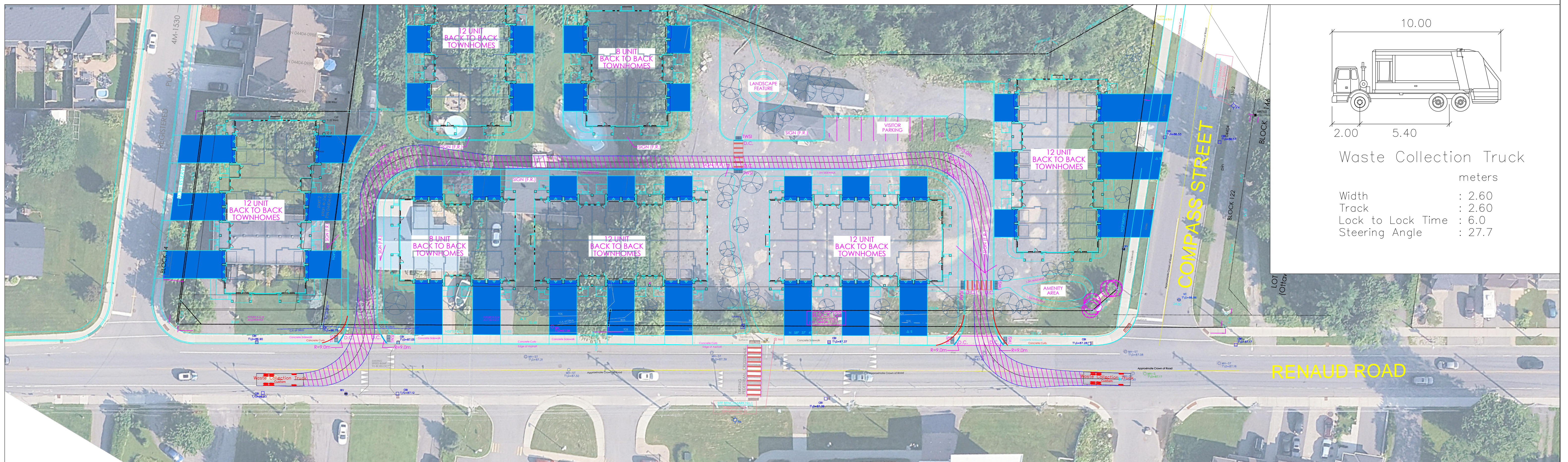

Waste Collection Truck

	meters
Width	: 2.60
Track	: 2.60
Lock to Lock Time	: 6.0
Steering Angle	: 27.7

CONSULTANT

Castleglenn Consultants
Engineers, Project Managers & Planners

DESIGNED BY A.P. CHECKED BY
CONSULTANTS JOB NO.

CONCEPT PLAN
FOR DISCUSSION ONLY

FIRE TRUCK/WASTE COLLECTION TRUCK COMING FROM WEST

8.0m 0 8.0m
HORIZ 1: 400

SCALE

PLAN NUMBER

BLOCK 121		
TRAILSEDGE PHASE3		
STATUS DRAFT	DATE 02-04-2025	SHEET 02 OF 02