

2175 PRINCE OF WALES DRIVE,
CITY OF OTTAWA
PROPOSED COMMERCIAL / OFFICE DEVELOPMENT
(FOR ZONING BY-LAW AMENDMENT) -
TRANSPORTATION IMPACT ASSESSMENT (TIA)

FINAL REPORT

Presented to:

Mr. Mike Giampa
Transportation Project Manager
Transportation Review
Planning, Real Estate and Economic
Development Department
110 Laurier Avenue
Ottawa, Ontario K1P 1J1
mike.giampa@ottawa.ca

May 10th, 2024



Project 7327

CASTLEGLENN CONSULTANTS LTD.

THIRD PARTY DISCLAIMER

This study has been prepared by Castleglenn Consultants Inc. (“CGI”) for the benefit of the Client to whom it is addressed. The information and data contained herein represents CGI’s best professional judgment in light of the knowledge and information available to CGI at the time of preparation. Except as required by law, this study and the information and data contained herein are to be treated as confidential and may be used and relied upon only by the Client, its officers and employees. CGI denies any liability whatsoever to other parties who may obtain access to this study for any injury, loss or damage suffered by such parties arising from their use of, or reliance upon, this study or any of its contents without the express written consent of CGI and the Client.

TABLE OF CONTENTS

1.0	BACKGROUND & SCREENING RESULTS	1-1
1.1	BACKGROUND.....	1-1
1.2	SUMMARY OF DEVELOPMENT	1-1
1.3	SCREENING: TRIP GENERATION TRIGGERS.....	1-1
1.4	SCREENING: LOCATION TRIGGERS	1-2
1.5	SCREENING: SAFETY TRIGGERS	1-2
1.6	SCREENING CONCLUSIONS.....	1-2
2.0	SCOPING RESULTS	2-1
2.1	EXISTING AND PLANNED CONDITIONS	2-1
2.1.1	The Proposed Development	2-1
2.1.2	Existing Conditions.....	2-1
2.1.2.1	Study Area Roadways	2-2
2.1.2.2	Study Area Intersections	2-2
2.1.2.3	Existing Surrounding Driveways	2-5
2.1.2.4	Existing Pedestrian Facilities	2-8
2.1.2.5	Existing Bicycle Facilities.....	2-8
2.1.2.6	Existing Transit Provisions	2-10
2.1.2.7	Area Traffic Management	2-11
2.1.2.8	Existing Peak Hour Travel Demands by Mode	2-12
2.1.2.9	Existing Road Safety Information	2-17
2.1.3	Planned Conditions	2-22
2.1.3.1	Changes to the Study Area Transportation Network	2-22
2.1.3.2	Other Study Area Developments.....	2-24
2.2	STUDY AREA AND TIME PERIODS.....	2-25
2.2.1	Study Area	2-25
2.2.2	Time Periods	2-25
2.2.3	Horizon Years	2-25
2.3	EXEMPTION REQUEST	2-25
3.0	FORECASTING	3-1
3.1	DEVELOPMENT-GENERATED TRAFFIC DEMAND	3-1
3.1.1	Trip Generation and Mode Shares	3-1
3.1.1.1	Auto Trip Generation Rates.....	3-1
3.1.1.2	Person Trips and Mode Shares	3-2
3.1.2	Trip Distribution	3-3
3.1.2.1	Traffic Distribution by Access	3-4
3.1.3	Trip Assignment.....	3-5
3.1.4	Resulting Site Generated Traffic Volumes	3-5
3.1.5	The TIA Report and Application for a Zoning Amendment.....	3-5
3.2	BACKGROUND NETWORK TRAVEL DEMAND	3-10
3.2.1	Transportation Network Plans.....	3-10
3.2.2	Background Growth.....	3-10
3.2.3	Other Identified Developments	3-10
3.2.4	Background Traffic Forecasts and Analysis	3-10
3.3	DEMAND RATIONALIZATION	3-14
3.3.1	Total Travel Demand	3-14
4.0	STRATEGY	4-1

4.1	DEVELOPMENT DESIGN.....	4-1
4.1.1	Design for Sustainable Modes	4-1
4.1.2	Circulation and Access.....	4-1
4.2	PARKING	4-2
4.2.1	Parking Requirements	4-2
4.2.1.1	Vehicle Parking	4-2
4.2.1.2	Bicycle Parking	4-3
4.3	BOUNDARY STREETS.....	4-4
4.3.1	Prince of Wales Widening ESR	4-4
4.3.2	Mobility	4-4
4.3.3	Road Safety	4-6
4.3.4	Neighbourhood Traffic Management.....	4-6
4.4	ACCESS INTERSECTIONS.....	4-6
4.4.1	Location and Design of Accesses	4-6
4.4.2	Access Control	4-6
4.4.3	The Proposed Accesses and the Future Multi-Use Pathway	4-7
4.4.4	Intersection Design	4-7
4.5	TRANSPORTATION DEMAND MANAGEMENT	4-8
4.5.1	Context for TDM	4-8
4.5.2	Need and Opportunity	4-8
4.5.3	TDM Program	4-8
4.6	NEIGHBOURHOOD TRAFFIC CALMING.....	4-9
4.7	TRANSIT.....	4-10
4.7.1	Route Capacity.....	4-10
4.7.2	Transit Priority	4-10
4.7.3	Future Changes to Transit Network	4-10
4.8	REVIEW OF NETWORK CONCEPT	4-11
4.8.1	Affected Links	4-12
4.8.2	Adequacy of Network Concepts	4-12
4.8.3	Screenlines	4-13
4.9	NETWORK INTERSECTIONS.....	4-13
4.9.1	Intersection Control.....	4-14
4.9.2	Intersection Design	4-14
4.9.2.1	MMLOS Analysis	4-14
4.9.2.2	Operations Analysis - Option 1: Auto Dealership (80,000 sqft) Traffic	4-16
4.9.2.3	Operations Analysis - Option 2: Hotel (400 Rooms) Traffic	4-16
4.9.2.4	Operations Analysis - Option 3: Office (80,000 sqft) Traffic	4-23
4.9.2.5	Operations Analysis - Option 4: Retail Plaza (70,000 sqft) Traffic	4-23
4.9.3	Access Operations.....	4-30
4.9.3.1	Location and Design of Access	4-30
4.9.3.2	Access Design	4-30
4.9.3.3	Access Operations	4-31
4.9.3.4	Queue Spillover into the Site.....	4-32
4.9.4	Traffic Analysis Conclusions.....	4-32
5.0	SIGN-OFF.....	5-1

APPENDICES

APPENDIX A – TIA SCREENING FORM AND PROJECT MANAGER CERTIFICATION FORM “A”

APPENDIX B – EXISTING TRAFFIC COUNTS, VOLUMES, COLLISIONS “B”

APPENDIX C – SYNCHRO ANALYSIS OUTPUT SHEETS EXISTING (2023) “C”

APPENDIX D – PROPOSED ACCESS CONCEPT “D”

APPENDIX E - SYNCHRO ANALYSIS OUTPUT SHEETS BACKGROUND (2025 AND 2030) “E”

APPENDIX F – TDM SUPPORTIVE DEVELOPMENT DESIGN AND INFRASTRUCTURE CHECKLIST “F”

APPENDIX G – TURNING MOVEMENT ANALYSIS AT THE PROPOSED ACCESS “G”

APPENDIX H – TDM MEASURES CHECKLIST “H”

APPENDIX I – INTERSECTION MMLOS ANALYSIS SHEETS “I”

APPENDIX J - SYNCHRO ANALYSIS OUTPUT SHEETS TOTAL (2025 AND 2030) “J”

APPENDIX K – CITY STAFF COMMENT RESPONSES “K”

LIST OF TABLES

TABLE 2-1: STUDY AREA ROADWAYS.....	2-2
TABLE 2-2: SUMMARY OF ADJACENT DRIVEWAYS.....	2-7
TABLE 2-3: EXISTING TRANSIT ROUTES	2-11
TABLE 2-4: EXISTING TRAFFIC COUNT INFORMATION	2-12
TABLE 2-5: PEDESTRIAN TRAVEL DEMAND	2-12
TABLE 2-6: CYCLIST TRAVEL DEMAND.....	2-13
TABLE 2-7: EXISTING (2023) TRAFFIC ANALYSIS.....	2-16
TABLE 2-8: FIVE-YEAR INTERSECTION COLLISION HISTORY	2-18
TABLE 2-9: FIVE-YEAR MID-BLOCK COLLISION HISTORY	2-18
TABLE 2-10: SUMMARY OF FIVE-YEAR COLLISION INFORMATION.....	2-21
TABLE 2-11: EXEMPTIONS AS PER TIA GUIDELINES.....	25
TABLE 3-1: SUMMARY OF TRIP GENERATION RATES BY SCENARIO	3-1
TABLE 3-2: SUMMARY OF VEHICLE TRIPS GENERATED BY SCENARIO	3-2
TABLE 3-3: EXISTING MODE SHARES	3-2
TABLE 3-4: SUMMARY OF PERSON TRIPS GENERATED IN EACH LAND USE SCENARIO BY MODE	3-3
TABLE 3-5: SUMMARY OF FORECASTED TRIP DISTRIBUTION	3-4
TABLE 3-6: TRIP DISTRIBUTION BY ACCESS.....	3-4
TABLE 3-7: SUMMARY OF VEHICLE TRIPS GENERATED BY SCENARIO AND RELEVANT EXHIBITS.....	3-5
TABLE 3-8: BACKGROUND (2025 AND 2030) TRAFFIC ANALYSIS	3-11
TABLE 4-1: PARKING REQUIREMENTS	4-3
TABLE 4-2: BICYCLE PARKING REQUIREMENTS	4-3
TABLE 4-3: SEGMENT MMLOS ANALYSIS RESULTS.....	4-4
TABLE 4-4: NEIGHBOURHOOD TRAFFIC CALMING CRITERIA.....	4-9
TABLE 4-5: INTERSECTION MMLOS ANALYSIS	4-14
TABLE 4-6: TOTAL (2025 AND 2030) TRAFFIC ANALYSIS [ASSUMING 80,000 SF AUTO DEALERSHIP].....	4-19
TABLE 4-7: TOTAL (2025 AND 2030) TRAFFIC ANALYSIS [ASSUMING 400-ROOM HOTEL].....	4-22
TABLE 4-8: TOTAL (2025 AND 2030) TRAFFIC ANALYSIS [ASSUMING 80,000 SF OFFICE].....	4-26
TABLE 4-9: TOTAL (2025 AND 2030) TRAFFIC ANALYSIS [ASSUMING 70,000 SF RETAIL PLAZA].....	4-29
TABLE 4-10: CLEAR THROAT LENGTH REQUIREMENTS.....	4-31

LIST OF EXHIBITS

EXHIBIT 2-1: LOCATION OF PROPOSED DEVELOPMENT	2-1
EXHIBIT 2-2: HUNT CLUB ROAD / PRINCE OF WALES INTERSECTION	2-3
EXHIBIT 2-3: PRINCE OF WALES / DEAKIN STREET INTERSECTION	2-4
EXHIBIT 2-4: PRINCE OF WALES / WATERBEND LANE INTERSECTION	2-5
EXHIBIT 2-5: PRINCE OF WALES DRIVE / ESSO SERVICE STATION ACCESS INTERSECTION	2-6
EXHIBIT 2-6: ACCESS ARRANGEMENT INTO ESSO STATION	2-6
EXHIBIT 2-7: ADJACENT DRIVEWAYS.....	2-7
EXHIBIT 2-8: PEDESTRIAN NETWORK WITHIN THE STUDY AREA.....	2-8
EXHIBIT 2-9: EXISTING CYCLING INFRASTRUCTURE IN THE STUDY AREA	2-9
EXHIBIT 2-10: ULTIMATE CYCLING NETWORK IN THE STUDY AREA.....	2-9
EXHIBIT 2-11: TRANSIT NETWORK WITHIN THE STUDY AREA.....	2-10
EXHIBIT 2-12: TRUCK ROUTES WITHIN THE STUDY AREA.....	2-11
EXHIBIT 2-13: ACTUAL TRAFFIC COUNTS: MORNING AND AFTERNOON PEAK HOUR TRAFFIC VOLUMES	2-14
EXHIBIT 2-14: 2023 BALANCED MORNING AND AFTERNOON PEAK HOUR TRAFFIC VOLUMES.....	2-15
EXHIBIT 2-15: LOCATION OF MID-BLOCK COLLISIONS & PROPOSED EXTENSION OF MEDIAN.....	2-19
EXHIBIT 2-16: UNDIVIDED SEGMENT OF PRINCE OF WALES DRIVE.....	2-19
EXHIBIT 2-17: ACTIVE TRANSPORTATION PROJECTS.....	2-22
EXHIBIT 2-18: ADJACENT PROPOSED DEVELOPMENTS	2-24
EXHIBIT 3-1: MYERS CUSTOMER MAPPING	3-3
EXHIBIT 3-2: SITE-GENERATED TRAFFIC OPTION 1: 80,000 SF AUTO DEALERSHIP.....	3-6
EXHIBIT 3-3: SITE-GENERATED TRAFFIC OPTION 2: 400 ROOM HOTEL	3-7
EXHIBIT 3-4: SITE-GENERATED TRAFFIC OPTION 3: 80,000 SQFT OFFICE	3-8
EXHIBIT 3-5: SITE-GENERATED TRAFFIC OPTION 4: 70,000 RETAIL PLAZA	3-9
EXHIBIT 3-6: BACKGROUND 2025 TRAFFIC FORECAST.....	3-12
EXHIBIT 3-7: BACKGROUND 2030 TRAFFIC FORECAST.....	3-13
EXHIBIT 4-1: 25M LONG CAR CARRIER DESIGN VEHICLE: GEOMETRIC ATTRIBUTES	4-2
EXHIBIT 4-2: DISTANCES TO NEAREST FUTURE LRT STATIONS (SCHEDULE A OP).....	4-11
EXHIBIT 4-3: ADJACENT SCREENLINES.....	4-13
EXHIBIT 4-4: TOTAL 2025 TRAFFIC FORECAST [80,000 SQFT AUTO DEALERSHIP].....	4-17
EXHIBIT 4-5: TOTAL 2030 TRAFFIC FORECAST [80,000 SQFT AUTO DEALERSHIP].....	4-18
EXHIBIT 4-6: TOTAL 2025 TRAFFIC FORECAST [400 ROOM HOTEL].....	4-20
EXHIBIT 4-7: TOTAL 2030 TRAFFIC FORECAST [400 ROOM HOTEL].....	4-21
EXHIBIT 4-8: TOTAL 2025 TRAFFIC FORECAST [80,000 SQFT OFFICE]	4-24

EXHIBIT 4-9: TOTAL 2030 TRAFFIC FORECAST [80,000 SQFT OFFICE]4-25
EXHIBIT 4-10: TOTAL 2025 TRAFFIC FORECAST [70,000 SQFT RETAIL PLAZA].....4-27
EXHIBIT 4-11: TOTAL 2030 TRAFFIC FORECAST [70,000 SQFT RETAIL PLAZA].....4-28
EXHIBIT 4-12: PROPOSED ACCESS DESIGN4-30

1.0 BACKGROUND & SCREENING RESULTS

1.1 BACKGROUND

The 2017 City of Ottawa “*Transportation Impact Assessment Guidelines*” set out a multi-step pre-application process where the scope, assumptions, study area and methodology to conduct a transportation impact assessment (TIA) are detailed. Each sequential stage of the TIA process is to be approved by City staff.

The July 2023 update to the City’s TIA guidelines have effectively sub-divided Step 3 (Forecasting) into components belonging to both Steps 1 & 2 (Screening and Scoping), and the former Step 4 (Strategy Report).

- Screening and Scoping Report (steps 1 and 2) was submitted on December 18th, 2023 to City staff and subsequently reviewed with City comments being forwarded on January 8th, 2024.
- Strategy Report addressing steps 3 & 4 (Forecasting and Strategy) were submitted on March 14, 2024 and comments on the submission were received on April 12, 2024.
- This report represents the final TIA submission, compiling all of the previous submissions together and addressing comments from each submission;
- City staff comments and responses are documented within Appendix “K”

1.2 SUMMARY OF DEVELOPMENT

The purpose of this submission is to serve as background to a request for a zoning by-law amendment that pertains to the 2175 Prince of Wales Drive site. The proponent wishes to have zoning in place that would permit any one of the following land uses:

- An auto dealership,
- A hotel,
- An office building, or
- A retail plaza

At the time of writing the proponent of the development has not confirmed which of the intended land uses would be going forward to site plan approval. The proponent recognizes that to proceed onto site plan approval a single land use must be selected, and an update to this document may very well be required.

1.3 SCREENING: TRIP GENERATION TRIGGERS

For the purposes of this report, each of the four land uses were assigned a development thresholds based on a maximum or upper development potential that would represent a “worst-case” traffic impact.

- An auto dealership with up to 80,000 ft² of gross floor area (GFA),
- A hotel with up to 400 rooms,
- An office building with up to 80,000 ft² of office space, or
- A retail plaza with up to 70,000 ft² of building GFA (excluding a supermarket / grocery store or drive-thru fast-food restaurant-type land use.)

Assuming each of the individual land use scenarios above the trip generation trigger would be fulfilled. Hence, **the TIA trip generation trigger of the Screening Report would be satisfied.**

1.4 SCREENING: LOCATION TRIGGERS

The proposed development proposes two access driveways onto the Prince of Wales Drive corridor. Prince of Wales drive is designated as Cross-Town Bikeway within the 2013 Cycling Plan¹.

Hence, **the TIA location trigger would be satisfied.**

1.5 SCREENING: SAFETY TRIGGERS

The proposed access driveways to the 2175 Prince of Wales Drive development would be located within the area of influence of the respective adjacent traffic signals.

- The proposed south access (which prohibits left turns out of the site) is located less than 150 metres from Prince of Wales Drive/Deakin Street intersection,
- The proposed more northerly right-in/right-out access is less than 150 metres from the Hunt Club Road/Prince of Wales Drive intersection.

Therefore, **the TIA safety trigger would be satisfied.**

1.6 SCREENING CONCLUSIONS

The screening results indicate that all three triggers (trip generation, location and safety) were satisfied. Therefore, the TIA is required to address both the “Design Review” and “Network Impact” components of the Traffic Impact Assessment process.

¹ “Ottawa Cycling Plan”, November 2013

2.0 SCOPING RESULTS

2.1 EXISTING AND PLANNED CONDITIONS

2.1.1 The Proposed Development

Exhibit 2-1 illustrates the location of proposed site which is situated in the south-east quadrant of the Hunt Club Road/ Prince of Wales Drive intersection.

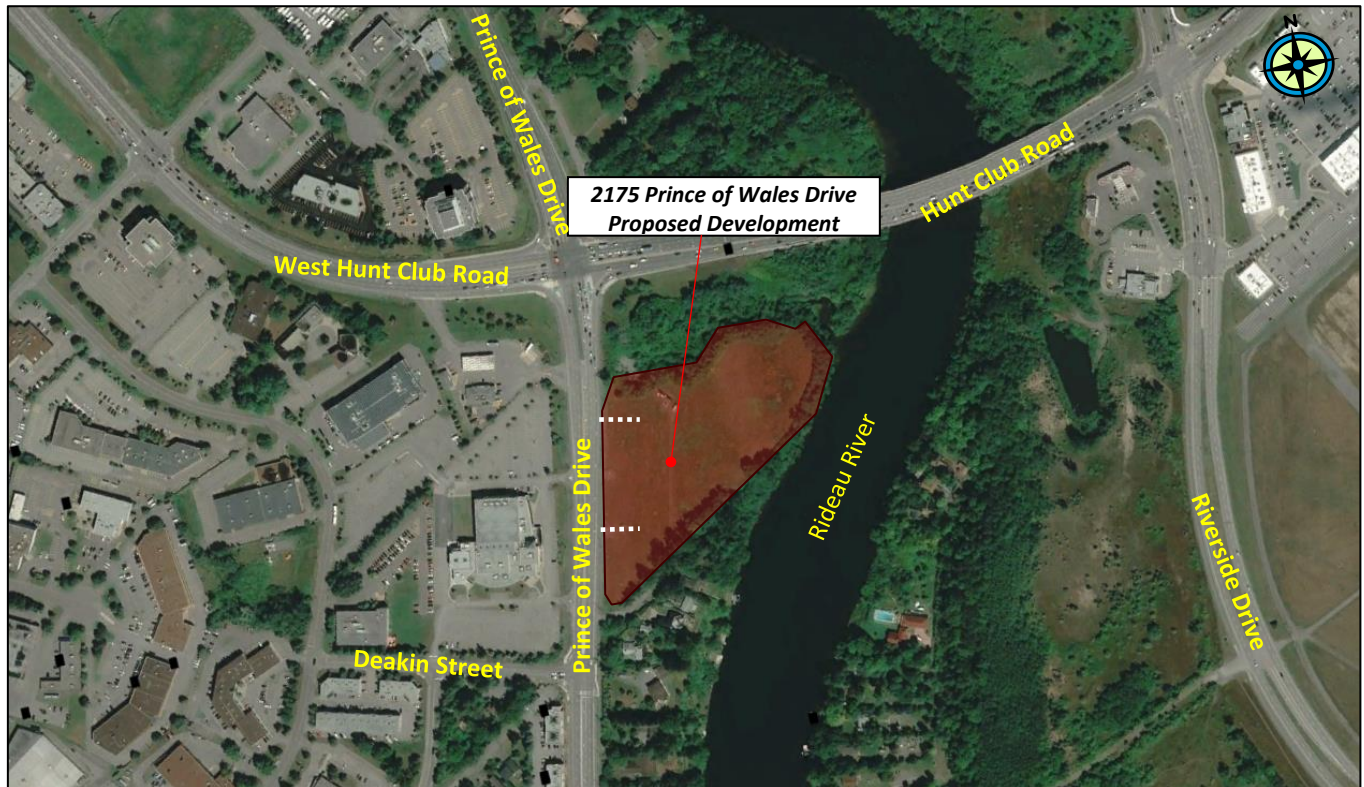

Exhibit 2-1: Location of Proposed Development

The 2175 Prince of Wales Drive parcel is irregularly shaped and currently zoned “*DR-Development Reserve Zone*”, intended for future urban development. The proponent is seeking to amend the existing zoning such that a commercial or office development would be possible. The amendment would be intended to provide the flexibility to develop the site as either a hotel, a car dealership, an office building, or a retail land use.

2.1.2 Existing Conditions

This section addresses the study area roadways and intersections adjacent to the development, existing pedestrian and cycling facilities, transit provisions, traffic management measures, peak hour travel demands by mode, intersection capacity, road safety, planned conditions and other planned developments in the area.

2175 Prince of Wales Drive Development, City of Ottawa, Ontario

2.1.2.1 Study Area Roadways

The City of Ottawa TMP (Map 8) was referenced, along with a desktop review of aerial photography, to document the existing roadways within the surrounding area that would serve the proposed development. Table 2-1 provides a summary of the public roadways in the vicinity of the proposed development.

Table 2-1: Study Area Roadways

Roadways	Description	On-Street Parking Provisions	Posted Speed	ROW Protection ²
<i>Prince of Wales Drive</i>	a 4-lane arterial undivided roadway. A non-continuous raised median exists ion the vicinity of signalized intersections	None in the vicinity of the study area	has a posted speed limit of 60 km/hr.	40-48 metres, subject to unequal requirements of Prince of Wales Widening ESR ³
<i>Hunt Club Road</i>	a 4-lane arterial divided roadway.		has a posted speed limit of 80 km/hr.	44.5 metres
<i>Deakin Street</i>	a 2-lane collector undivided roadway.		has a posted speed limit of 50 km/hr.	24 metres
<i>Waterbend Lane</i>	a 2-lane local roadway		No posted speed limit (50 km/hr applies)	N/A

2.1.2.2 Study Area Intersections

The following section of the report summarizes the geometrical characteristics of intersections within the study area.

² City of Ottawa Official Plan, Schedule C16

³ Prince of Wales Drive Widening Fisher Avenue to Woodroffe Avenue Environmental Study Report – Volume I. Morrison Hershfield, October 2011. Page 261, drawing 23 and 24

1. Hunt Club Road / Prince of Wales Drive Intersection

Exhibit 2-2 illustrates this 4-leg traffic signal-controlled intersection.

- The *eastbound approach* (West Hunt Club Road) provides for:
 - Two through lanes;
 - Two auxiliary left turn lanes;
 - One channelized right turn lane;
 - Two receiving lanes for through and left turning traffic; and
 - A 100-metre long receiving lane for right turns is provided which tapers off after the bus stop;
- The *westbound approach* (Hunt Club Road) provides for:
 - Two through lanes;
 - Two auxiliary left turn lanes;
 - One channelized right turn lane;
 - Two receiving lanes for through or left turning traffic; and
 - A 100-metre long taper on the receiving side is provided to assist right turning traffic merging onto Hunt Club Road.
- The *northbound approach* (Prince of Wales Drive) provides for:
 - Two through lanes;
 - One auxiliary left turn lane;
 - One channelized right turn lane;
 - Two receiving lanes for through and left turning traffic; and
 - A 100-metre long receiving lane for right turning traffic is provided which tapers off;
- The *southbound approach* (Prince of Wales Drive) provides for:
 - Two through lanes;
 - Two auxiliary left turn lanes;
 - One channelized right turn lane;
 - Two receiving lanes for through and left turning traffic; and
 - A 100-metre long taper on the receiving side is provided to assist right turning traffic merging onto Prince of Wales Drive.
- Cycling tracks are present on each approach.
- Pedestrian crosswalks are provided across each leg of the intersection.



Exhibit 2-2: Hunt Club Road / Prince of Wales Intersection

2. Prince of Wales Drive / Deakin Street Intersection

Exhibit 2-3 illustrates this 3-leg traffic signal-controlled intersection.

- The *northbound approach* (Prince of Wales Drive) provides for:
 - two through lanes; and
 - one auxiliary left turn lane.
 - two receiving lanes for southbound vehicles.
- The *southbound approach* (Prince of Wales Drive) provides for:
 - one through lane and
 - one shared through-right turn lane.
 - two receiving lanes for northbound vehicles.
- The *eastbound approach* (Deakin Street) provides for:
 - one left turn lane;
 - one shared left-right turn lane;
 - one receiving lane for westbound vehicles.
 - Pedestrian crosswalks are provided across the south and west legs of the intersection (northbound and eastbound approaches).
- Pedestrian crossing of the north leg (southbound approach) is prohibited.
- Cycling tracks along with cycling traffic lights which facilitate crossing the roadways are provided on each intersection approach;

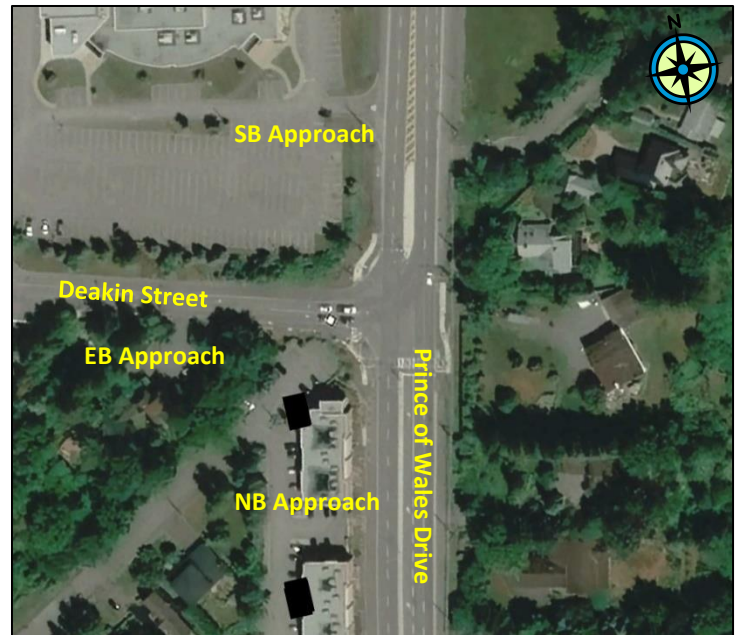

Exhibit 2-3: Prince of Wales / Deakin Street Intersection

3. Prince of Wales Drive / Waterbend Lane Intersection

- Exhibit 2-3 illustrates the 3-leg minor leg STOP-controlled intersection of Prince of Wales Drive and Waterbend Lane.
- Waterbend Lane is characterized as a narrow (~5 m wide) local roadway providing access to 5 single-family residential dwellings.
- The westbound approach (Waterbend Lane) provides for a right turn lane.
- The major northbound and southbound approaches (Prince of Wales Drive) provide for two travel lanes in each direction.
- Cycling lanes are provided along Prince of Wales Drive
- The intersection operates as right-in, right-out. However, aside from the painted median, there is no signage or physical barriers (i.e. raised median) restricting left turns into and out of the site.

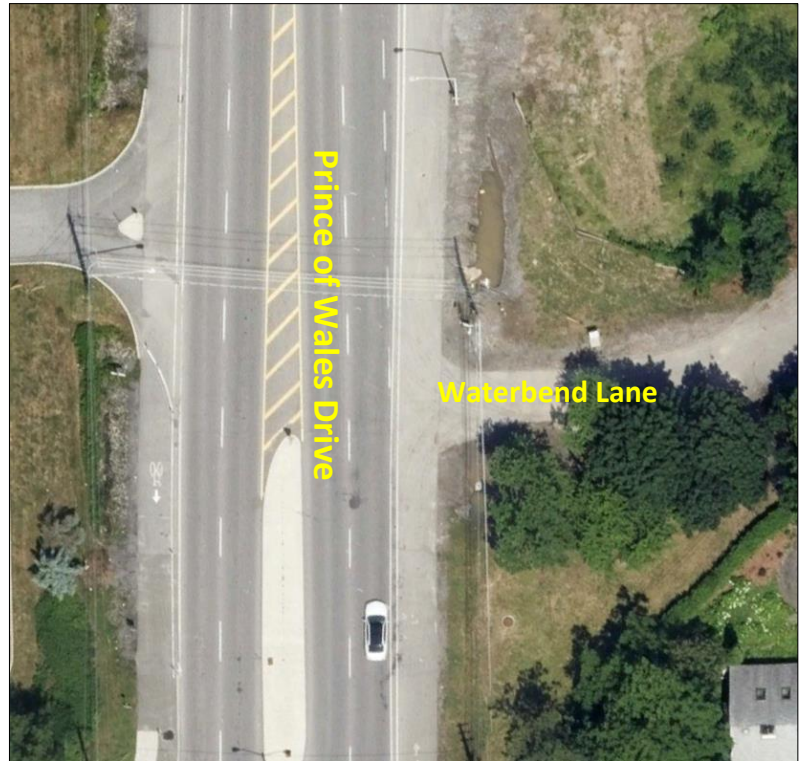

Exhibit 2-4: Prince of Wales / Waterbend Lane Intersection

2.1.2.3 Existing Surrounding Driveways

Exhibit 2-7 illustrates, and Table 2-2 describes the adjacent existing driveways within the immediate proximity of the proposed 2175 Prince of Wales Drive development. [The accesses within the study area were determined based upon a 200 meters distance from the edge of property line along each boundary street (Prince of Wales Drive and Hunt Club Road)]:

Prince of Wales Drive / Esso Service Station Access

Exhibit 2-5 and Exhibit 2-6 illustrate the uncontrolled Esso Service Station access. Operations at this intersection were analyzed separately to determine queuing in the northbound left turn lane.

- The access is located approximately 80 metres south of West Hunt Club Road.
- For the purposes of operational traffic analysis, the operations at the access were analyzed assuming STOP-control on the minor leg (Esso Service Station Access).
- The *eastbound approach* (Esso Service Station Access) provides for:
 - one right turn lane.
 - one receiving lane for the traffic entering the service station.



Exhibit 2-5: Prince of Wales Drive / Esso Service Station Access Intersection

- The *northbound approach* to the access (Prince of Wales Drive NB) provides for:
 - two through lanes.
 - one right turn lane for vehicles heading eastbound on Hunt Club Road.
 - one left turn lane for vehicles heading into the service station.



Exhibit 2-6: Access Arrangement into Esso Station

- The *southbound approach* (Prince of Wales Drive SB) provides for:
 - two through lanes.
 - one shared through-right. turn lane, which tapers off shortly after the access.
- The left turn out of the Esso Service Station site to Prince of Wales Drive is prohibited and restricted by a shaped centre median and a raised “porkchop” island.

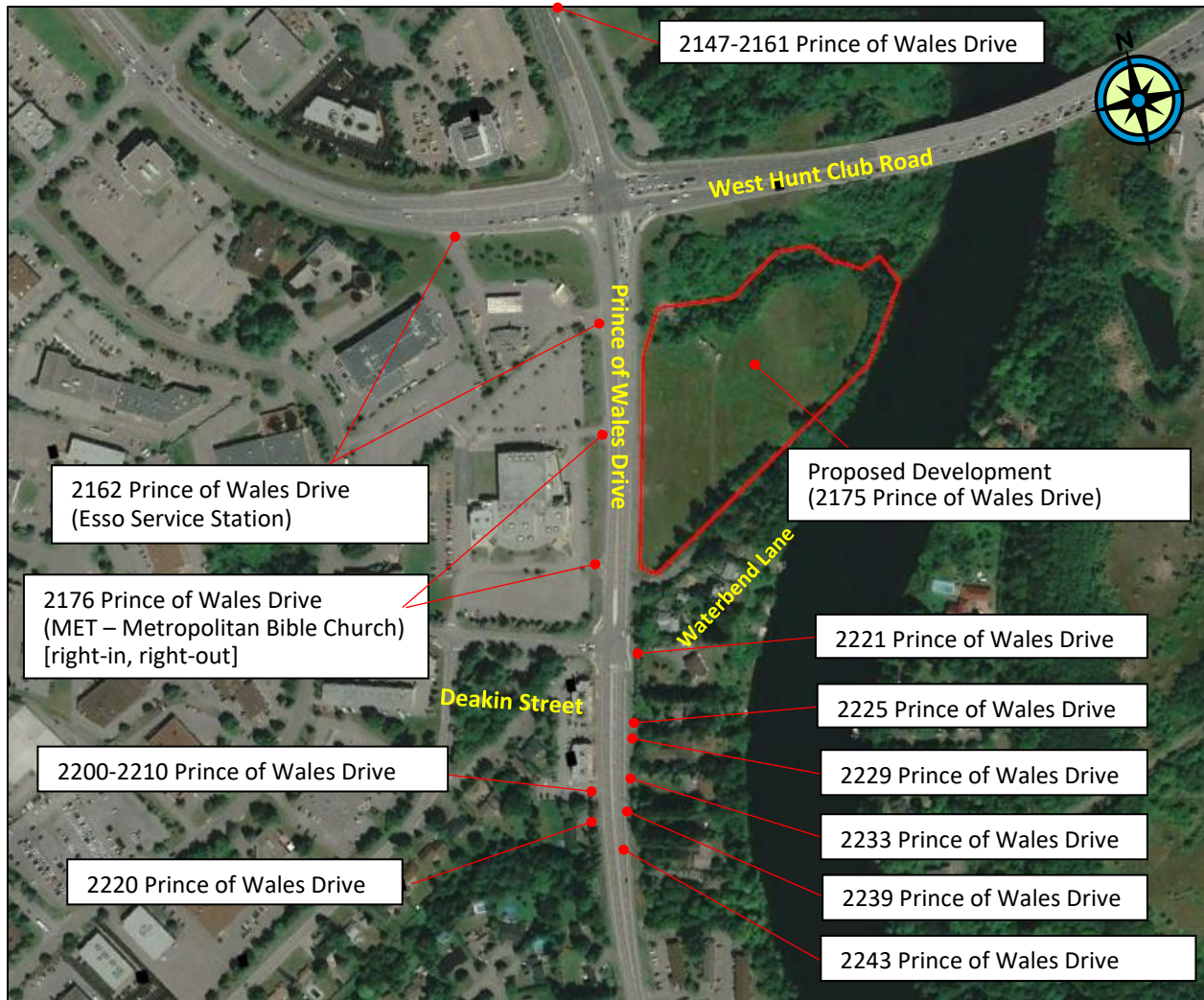

Exhibit 2-7: Adjacent Driveways

Table 2-2: Summary of Adjacent Driveways

Driveway Address		Description
2147-2161	Prince of Wales Drive	A driveway serving 4 (four) single-family detached dwellings
2221		Driveways serving single-family detached dwellings
2225		
2229		
2233		
2239		
2243		
2220		
2200-2210		A driveway serving two 3-storey office buildings
2176		Two right-in right-out driveways serving Metropolitan Bible Church (The MET)
2162		One driveway off Prince of Wales drive (see Exhibit 2-5), and one driveway off West Hunt Club Road serving the Esso Service Station

2.1.2.4 Existing Pedestrian Facilities

Exhibit 2-8 illustrates the pedestrian facilities within the study area. Sidewalks are provided:

- along Hunt Club Road and in each quadrant of the Hunt Club Road/Prince of Wales Drive intersection,
- Sidewalks are not provided on either side of Prince of Wales Drive between the Hunt Club Road and Deakin Street intersections,
- Sidewalks are provided in each quadrant of the Prince of Wales Drive/Deakin Street intersection with crosswalks on the west and south sides of the intersection,
- Sidewalks are provided along the south side of Deakin Street,
- Pedestrians may also use the paved shoulders / asphalt pathways provided on either side of Prince of Wales drive corridor within the study area.

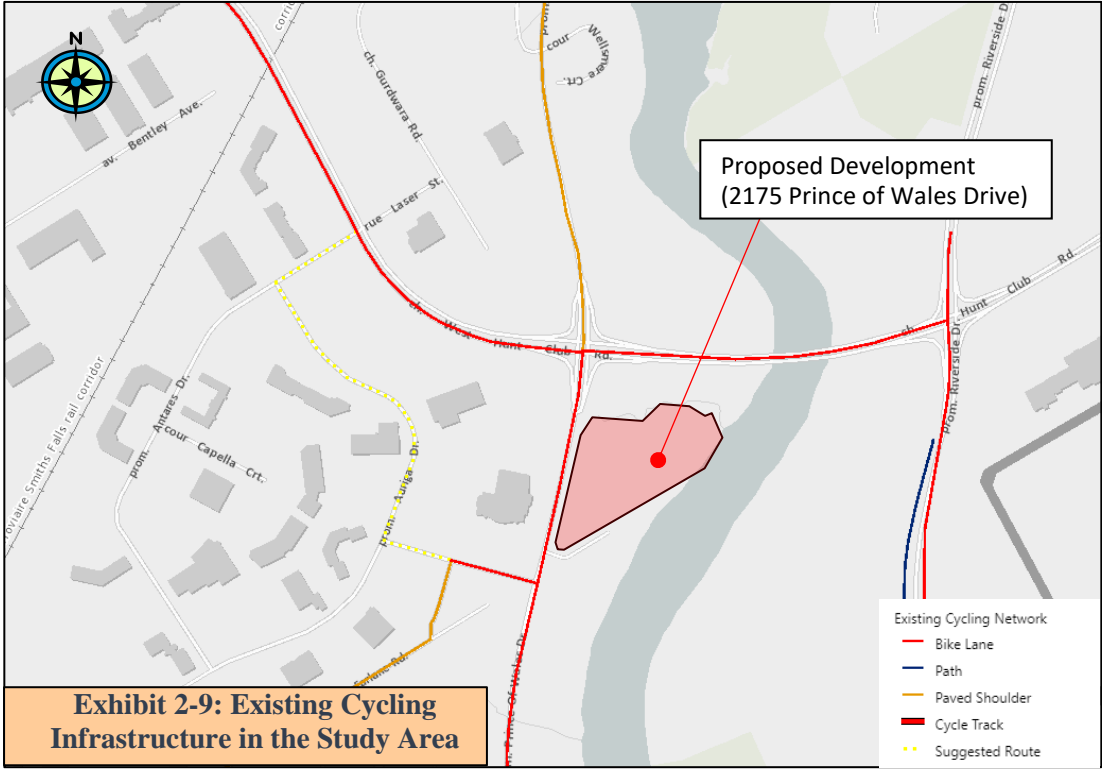

Exhibit 2-8: Pedestrian Network within the Study Area

2.1.2.5 Existing Bicycle Facilities

The City of Ottawa's 2013 Cycling Plan⁴ was referenced to identify the existing and ultimate cycling network which, for ease of reference, are illustrated within Exhibit 2-9 and Exhibit 2-10, respectively.

4 "Ottawa Cycling Plan", November 2013



Source: GeoOttawa; maps.ottawa.ca: City of Ottawa 2013 Cycling Plan

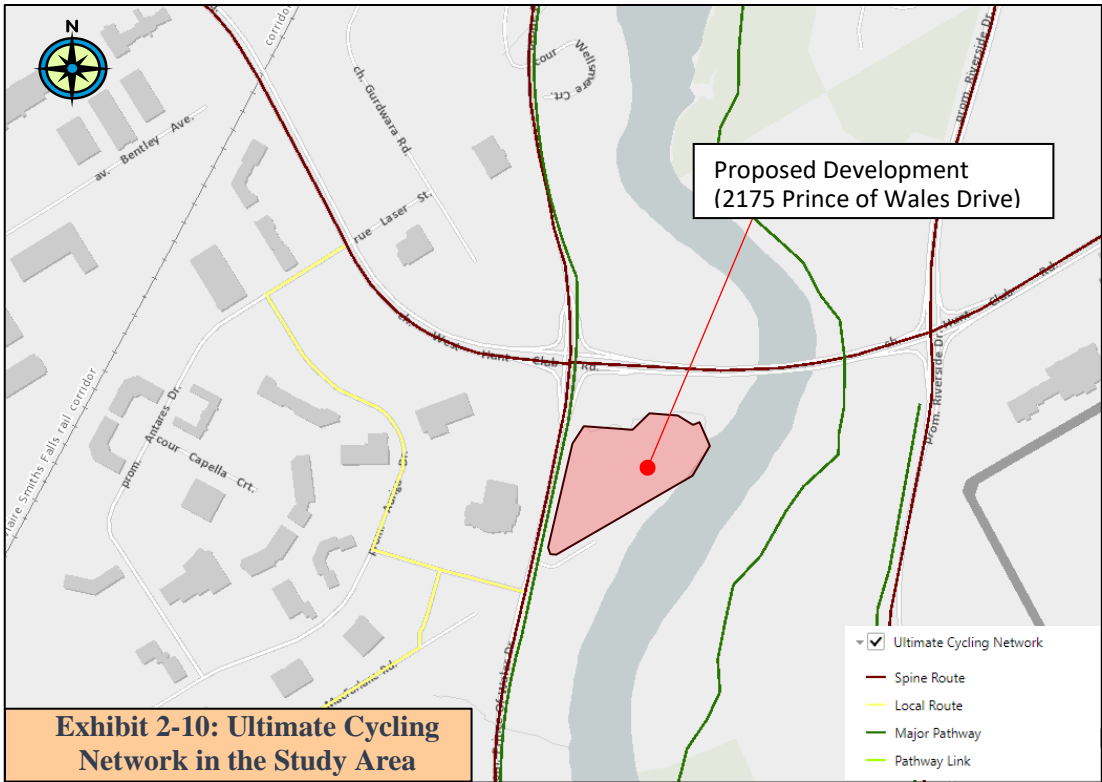

Source: GeoOttawa; maps.ottawa.ca: City of Ottawa 2013 Cycling Plan

The following is noted regarding the cycling network within the study area:

- Hunt Club Road and Prince of Wales Drive are designated as spine routes in the 2013 Cycling Plan;
- Within the DRAFT 2023 Transportation Master Plan, Prince of Wales corridor within the study area is designated as a Cross-Town Bikeway; and
- At the time of writing this report (November 2023), no additional cycling infrastructure projects within the study area were identified within the DRAFT 2023 Transportation Master Plan.

2.1.2.6 Existing Transit Provisions

Exhibit 2-11 illustrates, and Table 2-3 describes the existing (November 2023) transit operational service along roadways within the immediate proximity of the proposed development.

- The development site is best served by Routes 96 (and 96B), and 199, served by the following 2 closest bus stops (250-300 metre walking distance):

- Bus Stop #5815 serves the westbound direction; and
- Bus Stop #6098 serves the eastbound direction.

- Bus Stops serving Routes 80, 96, 187 and 670 are located on MacFarlane Road about 400 metre walking distance from the south access:

- Bus Stop #1955 serves the westbound direction; and
- Bus Stop #6085 serves the eastbound direction.

- Bus Stop #1601 serving Route 187 is located on Prince of Wales Drive about 200 metre walking distance from the south access:

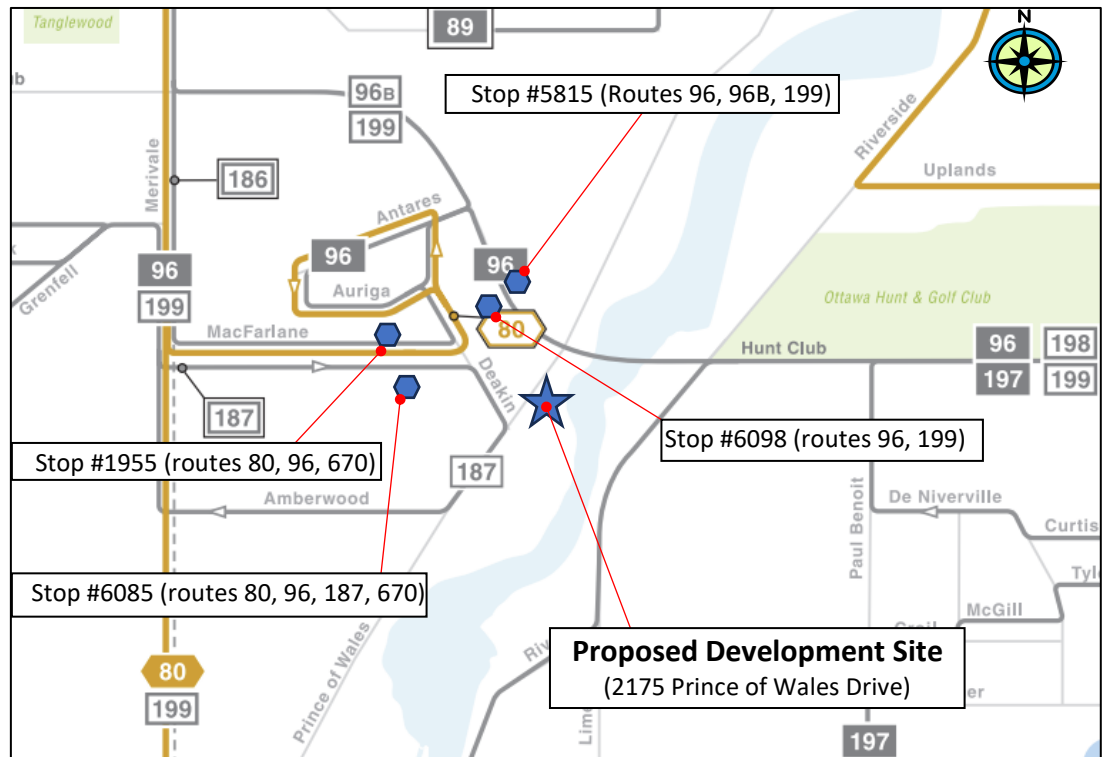

Source: OC Transpo Travel Planner, <https://www.octranspo.com/en/plan-your-trip/schedules-maps/network-map/>
Source: OC Transpo Travel Planner, plan.octranspo.com

Exhibit 2-11: Transit Network within the Study Area

Table 2-3: Existing Transit Routes⁵

Route	Type	Terminus 1	Terminus 2	Headways	Notes
80	Bus - Frequent	Barrhaven Centre	Tunney's Pasture	• 30 min-1 hour	• The route runs 7 days a week; • However, stops within the study area are only serviced Monday - Friday
96	Bus - Local	Merivale	Greenboro/Hurdman	• 30 min-1 hour	• 7 days a week; • Route 96B does not service stops 1955 and 6085
187	Bus - Local	Baseline	Amberwood	• 30 min-1 hour	• Monday-Friday service; • Peak Periods only
199	Bus - Local	Leikin	Hurdman	• 30 min-1 hour • 2 trips per direction per day	• Monday-Friday service; • 2 trips / peak direction / day • Peak Periods only
670	Bus - Regular	Nepean South	St. Pius High School	• N/A [2 trips per weekday]	• School route; • Monday-Friday service; • 1 trip per direction in the morning and afternoon

2.1.2.7 Area Traffic Management

Heavy Vehicle Restrictions

Exhibit 2-12 illustrates the heavy truck network within the study area.

- Both Hunt Club Road and Prince of Wales Drive are designated as full load truck routes.
- Trucks are prohibited from entering Deakin Street, with signage present along Prince of Wales Drive.

There are no other Area Traffic Management measures that were identified within the study area.



**Exhibit 2-12: Truck Routes within the Study Area
(outlined in black)**

5. OC Transpo Travel Planner – Schedules & Maps

2.1.2.8 Existing Peak Hour Travel Demands by Mode

Table 2-4 indicates the existing traffic count information that was either referenced from City of Ottawa sources or manually collected in preparation for this strategy report.

Table 2-4: Existing Traffic Count Information

Intersection	Traffic Control	Source	Duration and Date of Traffic Count
1. <i>Hunt Club Road and Prince of Wales Drive</i>	Traffic Signal	City of Ottawa	8-hour TMC; Monday, February 10, 2020;
2. <i>Prince of Wales Drive and Deakin Street</i>	Traffic Signal	City of Ottawa	8-hour TMC; Tuesday, November 26, 2019;
3. <i>Prince of Wales Drive and Esso Service Station Access (Minor Leg Traffic Only)</i>	Minor Leg STOP-control	Manual Traffic Count	5-hour TMC; Tuesday, July 18, 2023;

The following limitations regarding the traffic counts are noted:

- The purpose of the traffic count conducted at the Prince of Wales Drive/Esso Service Station access was to determine the demand or queue-length associated with the northbound left turn lane into the Esso site from Prince of Wales Drive. The traffic from both the vehicles entering and leaving the existing Esso Service Station at this access was manually recorded on July 18, 2023. The north-south thru vehicle, pedestrian and cycling traffic along Prince of Wales Drive was not recorded.
- The traffic counts at the Prince of Wales Drive/Deakin Street and Hunt Club Road/Prince of Wales Drive intersections were conducted in the late Fall and Winter, respectively. The pedestrian and cyclist count at these two locations are indicated in Table 2-5 and Table 2-6 and are not representative of peak demand.
- The traffic balancing assumes traffic to and from the Metropolitan Bible Church (MET) is negligible during the weekday peak hours of travel demand along Prince of Wales Drive.

Appendix “B” provides detailed existing traffic count and traffic signal timing information.

Pedestrian Travel Demand

Table 2-5 summarizes peak hour and 8-hour pedestrian travel demands at the two signalized study area intersections.

Table 2-5: Pedestrian Travel Demand

Intersection	Hunt Club Road / Prince of Wales Drive (Winter Count)				Prince of Wales Drive / Deakin Street (Late Fall Count)			
	North Leg	South Leg	East Leg	West Leg	North Leg	South Leg	East Leg	West Leg
<i>Morning Pedestrian Demand</i>	0	1	0	0	0	0	0	1
<i>Afternoon Pedestrian Demand</i>	0	8	4	0	0	2	0	1
<i>8-Hour Pedestrian Demand</i>	1	24	5	9	0	3	1	10

Cyclist Travel Demand

Table 2-6 indicates morning and afternoon peak hours and 8-hour cyclist travel demands at the two traffic-signal controlled study area intersections.

Table 2-6: Cyclist Travel Demand

Intersection	Prince of Wales Drive / Hunt Club Road (Winter Count)				Prince of Wales Drive / Deakin Street (Late Fall Count)		
	NB	SB	EB	WB	SB	NB	EB
Approach / Movement							
<i>Morning Pedestrian Demand</i>	2	1	0	1	2	6	1
<i>Afternoon Pedestrian Demand</i>	0	0	1	2	3	2	3
<i>8-Hour Cycling Demand</i>	2	3	2	3	23	22	10

Vehicle Travel Demand

The actual morning and afternoon peak hour motor-vehicle traffic information described within Table 2-4 is illustrated in Exhibit 2-13.

As the traffic information was collected on different dates, fluctuations in the collected information were anticipated due to factors ranging from different weather conditions, construction activity (detours, lane restrictions), work-from-home arrangements, etc. The collected information had to be balanced such that the traffic leaving one intersection would balance with that arriving at a downstream intersection, allowing for mid-block accesses that would logically account for discrepancies.

The following factors were considered in the balancing approach:

- Traffic volumes along Prince of Wales Drive, Hunt Club Road and Deakin Street were augmented by an annual 0.5% annual growth rate to adjust the volumes to a 2023 horizon year. This was done to account for the growth in background traffic that occurred in the 4-year period between 2019-and-2023.
- The traffic volumes along Prince of Wales Drive were balanced in the northbound and southbound direction.

Exhibit 2-14 depicts the resulting existing balanced weekday morning and afternoon peak hour traffic volumes. It is worthwhile to note that the two southbound right-in-right-out accesses to the Metropolitan Bible Church saw no traffic during the time of the manual traffic count.

Exhibit 2-13: Actual Traffic Counts: Morning and Afternoon Peak Hour Traffic Volumes

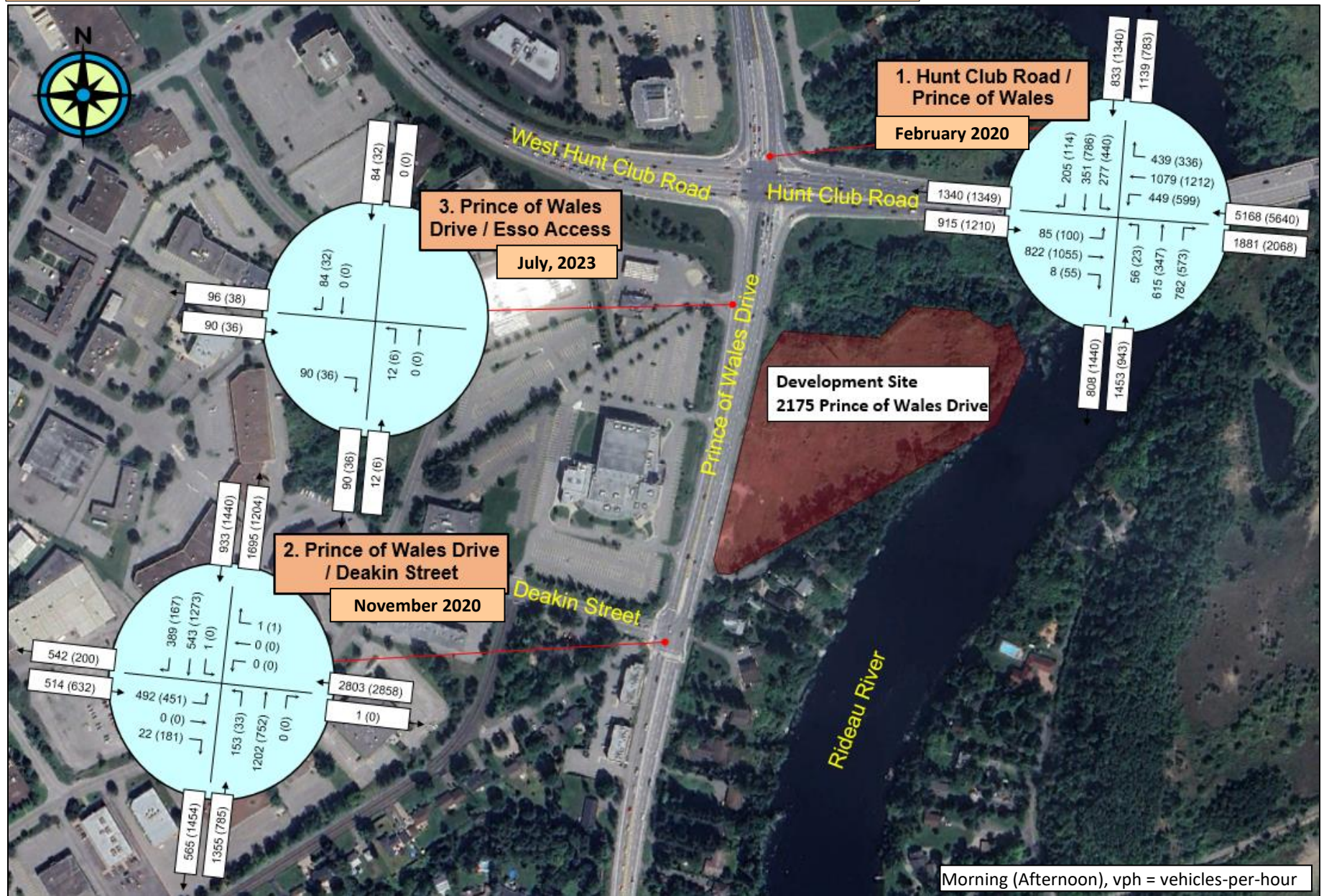
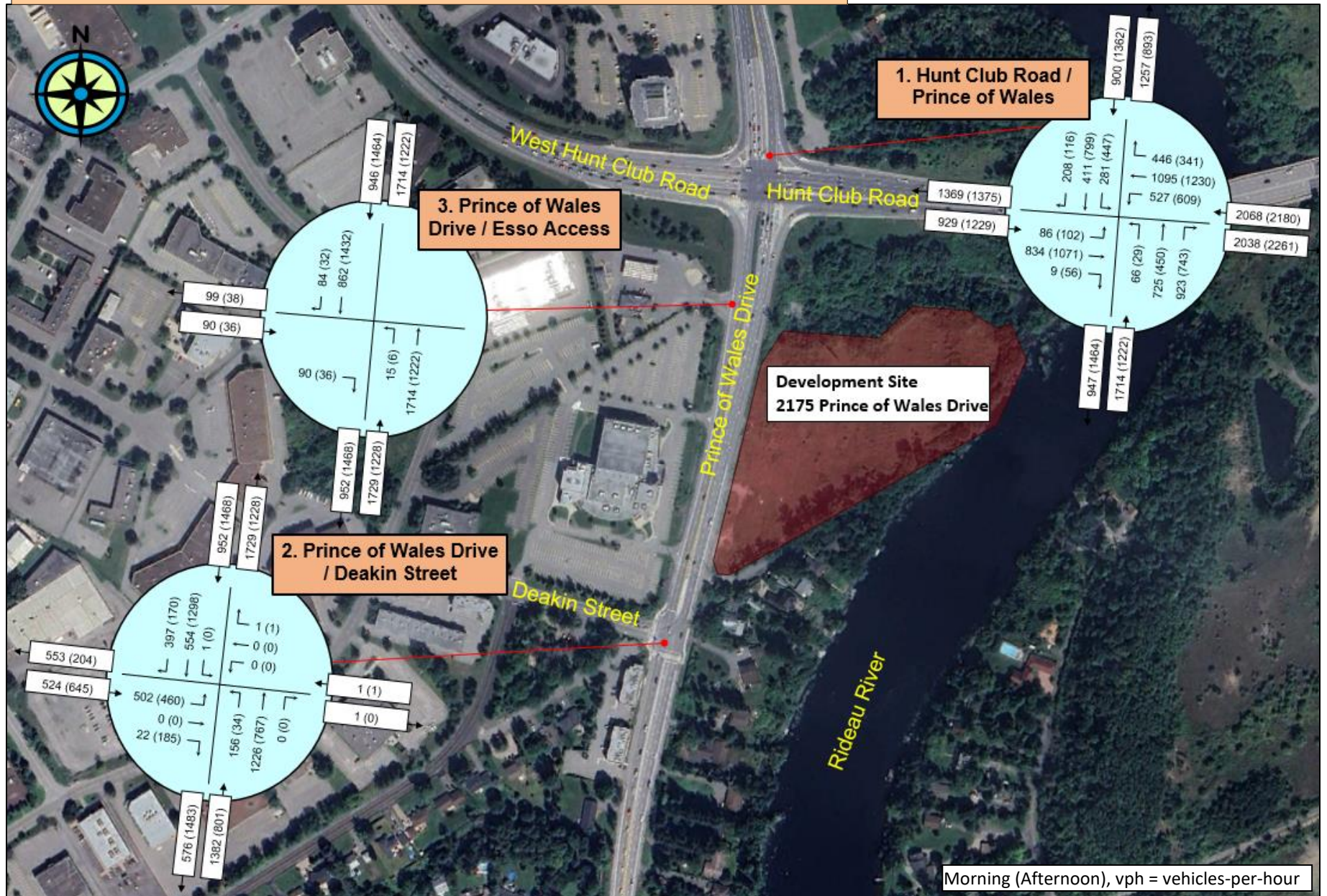

Exhibit 2-14: 2023 Balanced Morning and Afternoon Peak Hour Traffic Volumes



Existing Traffic Volumes: Intersection Capacity Analysis

Table 2-7 summarizes the existing balanced intersection capacity analysis results. This analysis assumes the development is not in place and accounts for the effects of background growth between the counts’ base year and the current year (2023).

Table 2-7: Existing (2023) Traffic Analysis
[Assumes Development is NOT in Place]

Intersection	Control Type	Weekday Morning Peak Hour (Afternoon Peak Hour)				
		Critical Movement	95 th Percentile Queue (m)	Delay (seconds)	v/c Ratio	LOS
1. Hunt Club Road and Prince of Wales Drive	Traffic Signal	NB-LT	33 (20)	78 (90.1)	0.56 (0.45)	A (A)
		NB-TH	137 (102)	63.7 (86.0)	0.90 (0.93)	E (E)
		NB-RT	408 (361)	327.6 (397)	1.65 (1.81)	F (F)
		EB-RT	0 (0)	0 (0.2)	0.02 (0.08)	A (A)
		SB-TH	69 (172)	42.8 (62.8)	0.47 (0.89)	A (D)
		WB-LT	126 (164)	154.4 (250.0)	1.19 (1.43)	F (F)
2. Prince of Wales Drive and Deakin Street	Traffic Signal	SB-TH	49 (132)	7.3 (14.9)	0.49 (0.73)	A (C)
		NB-TH	100 (49)	12.7 (9.2)	0.62 (0.37)	B (A)
		EB-LT	64 (112)	44.4 (75.0)	0.79 (0.99)	C (E)
3. Prince of Wales Drive and Esso Service Station Access	Assumed Minor Leg-STOP	EB-RT	8 (5)	18.2 (23.3)	0.27 (0.17)	A (A)
		NB-LT	2 (1)	16.3 (27.0)	0.05 (0.04)	A (A)

Analysis was undertaken using Synchro™ V11 traffic analysis software. See Appendix “C” for Synchro analysis output sheets.

Assumed 2023 balanced traffic volumes. See Exhibit 2-14.

Analysis was carried using the traffic-signal timings phasing that were provided by the City of Ottawa. See Appendix “B”.

Analysis assumes a peak hour factor (PHF) of 0.90.

Values outside of Brackets represent Morning Peak Hour Values.

Values inside of Brackets represent Afternoon Peak Hour Values.

Values that are in Bold indicate unsatisfactory results / parameters.

Movements that are forecast to be affected by the proposed development’s traffic are shown

Hunt Club Road / Prince of Wales Drive intersection: Table 2-7 indicates that the during both morning and afternoon peak hours of travel demand the NB-RT destined to the Hunt Club bridge and the WB-LT departing from the Hunt Club bridge are congested:

- The northbound right turn movement from Prince of Wales Drive onto Hunt Club Road exhibits a level of service “F” with an average delay of over 5 minutes during the morning peak hour of travel demand, and over 5 minutes during the afternoon peak hour. This is largely attributed to there being only 2 EB thru lanes on the Hunt Club Road bridge where 3-lanes are required. The YIELD at the right turn followed by the necessary merge results in back-ups occurring along the corridor. The queues along Prince of Wales Drive in the northbound right turn lane reach 408 metres, effectively stretching all along the proposed development’s frontage.

- The westbound left turn movement from Hunt Club Road onto Prince of Wales Drive SB, despite being provided with double left turn lanes, exhibits a level of service “F” during the weekday morning and afternoon peak hour of travel demand with average delays over two minutes during the morning peak hour of travel demand, and 3 minutes during the afternoon peak hour. The reason for this is the high volumes of opposing movements demand more signal time.

Prince of Wales / Deakin Street intersection: Table 2-7 indicates that during the afternoon peak hour of travel demand the eastbound left turn operates at a level of service “E” with an average delay of over one minute and a volume-to-capacity ratio of 0.99 during the afternoon peak hour of travel demand. The existing signal timing provides a preference to dominant north-south Prince of Wales Drive traffic volumes.

The Esso Service Station Access: Table 2-7 indicates that this access is operating at a level of service “A”, with a critical 95th percentile queue length of a single passenger vehicle (8 metres) during the morning peak hour.

According to the City of Ottawa’s MMLOS guidelines⁶, the minimum desirable vehicular LOS target (Auto-LOS) for arterial and collector roadways within “general urban area” as defined within the City’s Official Plan Designation / Policy Area as **LOS “D”**. It is important to emphasize that these results represent an existing condition and have little to do with the proposed development initiative.

2.1.2.9 Existing Road Safety Information

Historical collision information was reviewed for the study area intersections and segments. The collision information was referenced from the City of Ottawa for the period 2017-through-2021. (See Appendix “B”)

- the date and time of each collision
- the type of collision (e.g., angle collision, rear-end)
- the severity of damage involved
- vehicle details (truck, passenger vehicle, etc.)
- vehicle path/maneuver characteristics
- the number of pedestrians involved in the collision

Intersection Collisions: Table 2-8 provides a summary of intersection and mid-block collisions for the two traffic-signal controlled study area intersections and the collisions which occurred mid-block between the intersections for the 5-year period between 2017-through-2021. The collisions listed in the table highlight the type of collision and collision severity.

- The collision rate for the West Hunt Club Road/Prince of Wales intersection was determined to be 1.07. A collision rate greater than 1.0 collisions/MEV is considered to indicate a potential concern. The table indicates that two-thirds (91) of the 141 collisions that occurred at this intersection were rear-end collisions however, additional evaluation indicated that there was no discernible pattern as regards location of the rear end incidents as they were distributed evenly on each of the intersection approaches.

⁶ “Multi-Modal Level of Service (MMLOS) Guidelines”, Supplement to the TIA Guidelines, City of Ottawa September 2015, IBI Group. Page 24, Exhibit 22 – Minimum Desirable MMLOS Targets by Official Plan Policy Designation & Road Class.

Table 2-8: Five-Year Intersection Collision History
(January 1st, 2017 -to- December 31st, 2021)

Intersection Collisions: Table 2-8 presents for each intersection a calculated collision rate based on the number of collisions- per-million-entering-vehicles (MEV).

Intersections			
Intersection Number		1	2
Intersection		Hunt Club Road / Prince of Wales Drive	Prince of Wales Drive / Deakin Street
Total Collisions		141	26
Collision Type	Approaching	1	0
	Angle	13	2
	Rear End	91	15
	Sideswipe	29	6
	Turning Movement	2	2
	Single Vehicle	3	1
	Other	2	0
Collision Severity	Property Damage only	116	19
	Non-Fatal Injury	25	7
	Fatal	0	0
No. of Collisions Involving Pedestrians		0	0
No. of Collisions Involving Cyclists		1	1
Intersection AADT		72,100	36,400
Collision Rate per MEV		1.07	0.39

Table 2-9: Five-Year Mid-Block Collision History
(January 1st, 2017 -to- December 31st, 2021)

Mid-Block			
Intersection Number		3	4
Street		Prince of Wales Drive	
Between		West Hunt Club Road	Waterbend Lane
... and		Waterbend Lane	Deakin Street
Total Collisions		19	1
Collision Type	Approaching	0	0
	Angle	2	0
	Rear End	6	1 NB
	Sideswipe	3	0
	Turning Movement	8	0
	Single Vehicle	0	0
	Other	0	0
Collision Severity	Property Damage only	17	1
	Non-Fatal Injury	2	0
	Fatal	0	0
No. of Collisions Involving Pedestrians		0	0
No. of Collisions Involving Cyclists		0	0

Mid-Block Collisions: Table 2-9 presents the collision related information that occurred on the mid-block segment of Prince of Wales Drive between the West Hunt Club Road and Deakin Street intersections.

Mid-Block Collisions: Table 2-9 indicates that the mid-block sections experienced 19 collisions over the 5-year period of which 8 (42%) were turning movement incidents.

Additional evaluation of this mid-block section indicated that of the 8 incidents:

- 4 of the incidents occurred when a southbound vehicle attempted to make a U-turn.
- 3 of the incidents occurred when a northbound vehicle attempted to make a left turn; and
- The remaining incident occurred when a southbound vehicle made an improper lane change.

Exhibit 2-15 (left side) illustrates the geo-location of all the mid-block collisions which, if correct, appear to cluster around the portion of the Prince of Wales Drive which has no median.

Exhibit 2-15 (right side) illustrates the location of a proposed median associated with development of the subject site. The advent of the

proposed median will clearly have a beneficial effect on the reducing the incidence of mid-block U-turns and left turn collisions.

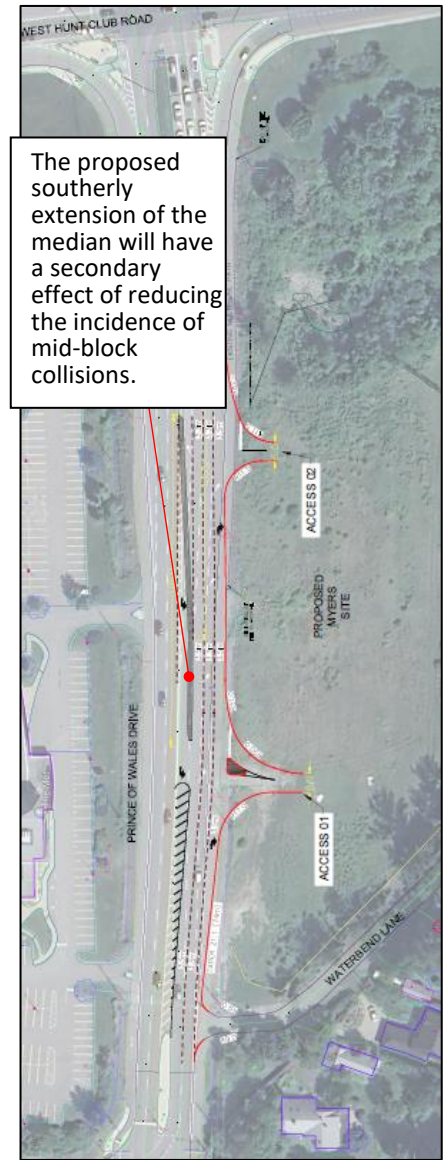

Exhibit 2-15: Location of Mid-block Collisions & Proposed Extension of Median



Exhibit 2-16: Undivided Segment of Prince of Wales Drive

Table 2-10 provides a more detailed summary of the available collision information and indicates the following:

- *Motor-Vehicle Incidents:* Of the 141 reported incidents at the Hunt Club Roads/Prince of Wales Drive the following findings were evident:
 - The 91 rear end collisions at the intersection were split roughly evenly on each approach to the intersection indicating no discernable pattern;
 - The 13 angled collisions that occurred over the 5 year period do not represent a significant enough sample to indicate any discernable pattern. The 13 incidents were found to be roughly distributed among all 4 approach directions;
 - Similarly, the 29 sideswipe incidents that occurred over the same 5 year period split roughly evenly on each approach to the intersection indicating no discernable pattern.”
 - *Cycling Incidents:* The following two cycling incidents, both of which resulted in non-fatal injuries, were reported within the five year period analyzed:
 - In 2018, a southbound cyclist on the west side of Prince of Wales Drive was struck by a northbound motor-vehicle making a left turn onto Deakin Street which failed to yield the right-of-way.
 - In 2019, a westbound cyclist travelling on the south side of West Hunt Club Road was struck by a northbound motor-vehicle making a right turn which failed to yield the right-of-way.
- The small sample of reported cycling incidents do not present any trends or discernable patterns.”

**Table 2-10: Summary of Five-Year Collision Information
(January 1st, 2017 -to- December 31st, 2021)**

1. Hunt Club Road and Prince of Wales Drive Intersection
This intersection is the junction of two major arterial roads with heavy through and turning volumes and exhibited the worst collision statistics within the study area, with 141 collisions recorded over the last 5 years of available information. The types of collisions were:
<ul style="list-style-type: none"> • 91 out of 141 (65%) were rear end collisions which were evenly distributed among the 4 approaches: • 29 out of 141 (21%) were sideswipe collisions; • 13 out of 141 (9%) were turning movement collisions.
The severity of the collisions included:
<ul style="list-style-type: none"> • 116 out of 141 (82%) resulted in property damage only; • 25 out of 141 (18%) resulted in non-fatal injuries;
There were no fatal collisions recorded in the 5 years of data provided;
There were no collisions involving a pedestrian recorded in the 5 years of data provided;
There was 1 (one) non-fatal collision involving a cyclist recorded in the 5 years of data provided;
On average, reported collisions at this intersection occur more than two times per month over the last 5 years. The resulting collision rate at this intersection is 1.07 collisions per million entering vehicles (MEV), which may indicate a potential safety concern.
2. Prince of Wales and Deakin Street Intersection
This intersection exhibited 26 recorded collisions over the last 5 years and resulted in a collision rate on 0.39 collisions per MEV;
<ul style="list-style-type: none"> • 15 out of 26 (58%) were rear end collisions; • 6 out of 26 (23%) were sideswipe collisions;
The severity of the collisions included:
<ul style="list-style-type: none"> • 19 out of 26 (73%) resulted in property damage only; • 7 out of 26 (27%) resulted in non-fatal injuries;
There were no fatal collisions recorded in the 5 years of data provided;
There were no collisions involving a pedestrian recorded in the 5 years of data provided;
There was 1 (one) non-fatal collision involving a cyclist recorded in the 5 years of data provided;
3. Mid-Block Roadway Segments on Prince of Wales Drive between Hunt Club Road and Deakin Street
A total of 20 collisions occurred along Prince of Wales Drive between Hunt Club Road and Deakin Street;
<ul style="list-style-type: none"> • 8 out of 20 (40%) were turning movement collisions; • 7 out of 20 (35%) were rear end collisions;
The severity of the collisions included:
<ul style="list-style-type: none"> • 18 out of 20 (90%) resulted in property damage only; • 2 out of 20 (10%) resulted in non-fatal injuries;
There were no fatal collisions recorded in the 5 years of data provided;
There were no collisions involving a pedestrian recorded in the 5 years of data provided;

2.1.3 Planned Conditions

2.1.3.1 Changes to the Study Area Transportation Network

2023 Transportation Master Plan

At the time of writing this report, Part 1 of the City’s new Transportation Master Plan (2023), (which addresses TMP policies, Active Transportation Projects and Networks, and Transit and Road Project Prioritization Framework) was available for review. However, Part 2 of the TMP, which details the Capital Infrastructure Plan remained to be finalized⁷.

Exhibit 2-17 illustrates a proposed sidewalk along Auriga Drive and Antares Drive between West Hunt Club Road and Deakin Street which was identified as the only active transportation project in the vicinity of the proposed development.

However, with the advent of the proposed development, both pedestrian and cycling facilities could be completed along the frontage of the Prince of Wales Drive site that would effectively complete the active transportation infrastructure between the Hunt Club Road intersection and the Deakin Street intersection benefiting both safety and active transportation objectives.



Exhibit 2-17: Active Transportation Projects

⁷ Transportation Master Plan Update, Engage Ottawa <https://engage.ottawa.ca/transportation-master-plan>
2175 Prince of Wales Drive Development, City of Ottawa, Ontario
Castleglenn Consultants Inc.

2013 Transportation Master Plan

A review of the City of Ottawa's former (2013) Transportation Master Plan (TMP) took place to identify previously envisioned roadway and transit objectives that were previously indicated to take place in the vicinity of the proposed development. These initiatives are detailed below:

a) Affordable Network (2031):

- Widening of Prince of Wales Drive between Hunt Club Road and Merivale Road (south of the site) is listed as a part of Phase 3 (completed in 2026-2031) of the 2031 Affordable Road Network⁸.
 - This project, once completed, would have no effect on the auto travel lane configuration within the immediate study area, since Prince of Wales Drive between Hunt Club Road and Deakin Avenue is already a 4-lane corridor. The widening is to occur south of Deakin Street;
 - A review of the 2011 Prince of Wales widening ESR indicated that northbound and southbound cycling lanes, a sidewalk on the west side of the corridor, and a 3 metre multi-use pathway were proposed.⁹;
 - The 2031 Network Concept expands the length of the corridor's widening to a 4-lane Prince of Wales Drive corridor between Fisher Avenue and Strandherd Drive. (See below.)

b) Transit Priority Projects:

- Transit Signal Priority and Queue Jump Lanes along West Hunt Club Road between Woodroffe Avenue and Riverside Drive is listed as part of Transit Priority Projects¹⁰.
 - This project is intended to improve transit service for bus trips bypassing the inner-city.

c) Network Concept Projects:

- Widening of Hunt Club Road east of Riverside Drive (until Bank Street) from four-to-six lanes¹¹;
- Widening of West Hunt Club Road west of Prince of Wales Drive until Highway 416 from four-to-six lanes¹²
 - Both of the two projects were intended to address capacity issues along Hunt Club Road;
- Widening of Prince of Wales Drive corridor between Fisher Avenue and Strandherd Drive from two-to-four lanes.
- Given these three projects are not part of the affordable road network, the completion of these projects is unlikely to occur before 2031. The impacts of any future widenings along the Hunt Club Road have not been considered within the scope of this TIA.

8 City of Ottawa 2013 Transportation Master Plan, Table A2- Transit Priority Projects, page 113

9 Prince of Wales Drive Widening Fisher Avenue to Woodroffe Avenue Environmental Study Report – Volume I. Morrison Hershfield, October 2011. Page 261, drawing 23 and 24

10 City of Ottawa 2013 Transportation Master Plan, Table A2- Transit Priority Projects, page 107

11 City of Ottawa 2013 Transportation Master Plan, Table A3- Road Projects, page 111

12 City of Ottawa 2013 Transportation Master Plan, Table A3- Road Projects, page 114

2.1.3.2 Other Study Area Developments

The City of Ottawa's Development Applications website¹³ was reviewed to identify adjacent proposed developments within the study area. A 0.5% annual traffic growth rate was used within this study that was assumed to account for all of the below development-related traffic growth.

The two proposed developments identified nearby the study area are:

- **3930-3960 Riverside Drive:** Exhibit 2-18 illustrates the location of a proposed residential subdivision that was addressed within a TIA prepared in December 2023¹⁴. The TIA document included provision for 24 single family homes, 53 townhouses and 590 apartment dwelling units within multiple phases. The TIA document indicated that the generated traffic associated with this development would be 169 vehicle trips during the morning peak hour (52 inbound and 117 outbound); and 170 vehicle trips during the afternoon peak hour (99 inbound and 71 outbound). However, only 20% of these trips are forecast to be destined to and from West Hunt Club Road within the study area.

- **2009-2013 Prince of Wales Drive:** Exhibit 2-18 illustrates the location of a proposed residential development that was addressed TIA prepared in November 2023¹⁵. The TIA document included provision for 7 single family homes. The TIA document indicated that the generated traffic associated with this development would be 4 vehicle trips during the morning peak hour (1 inbound and 3 outbound); and 4 vehicle trips during the afternoon peak hour (3 inbound and 1 outbound).

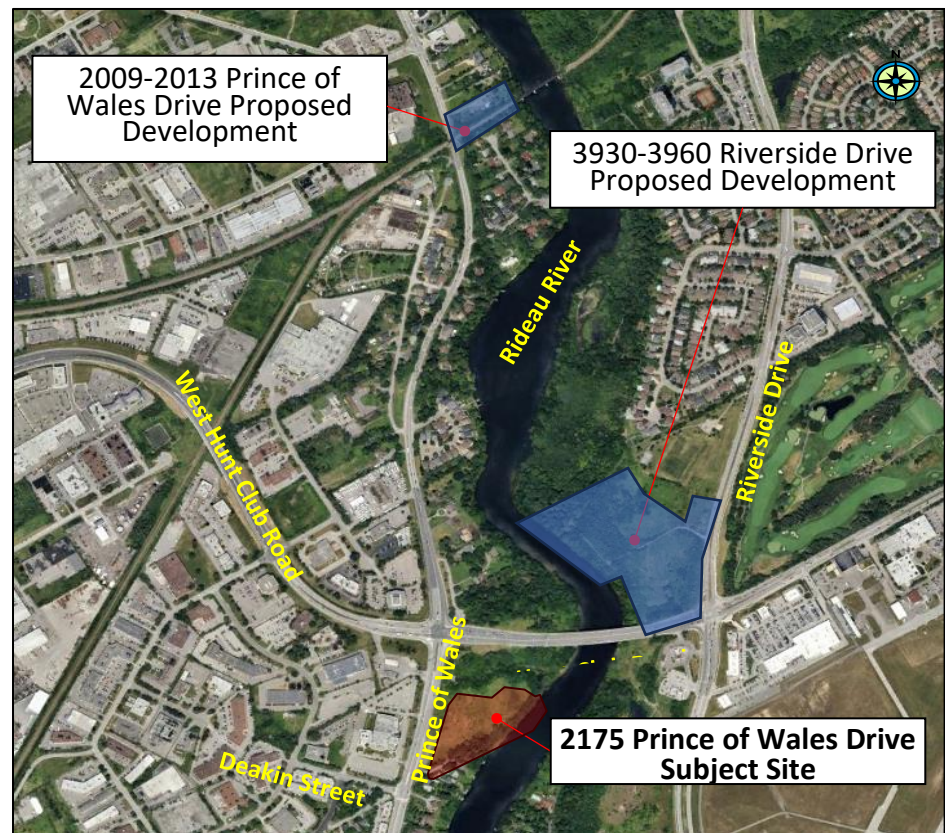

Exhibit 2-18: Adjacent Proposed Developments

13 Development Application Search Tool <https://devapps.ottawa.ca/en/applications>

14 "3930 & 3960 Riverside Drive TIA Final Report", Parsons, December 15, 2023.

15 "2009 & 2013 Prince of Wales Drive Transportation Impact Assessment", Novatech, November 2023.

2.2 STUDY AREA AND TIME PERIODS

2.2.1 Study Area

Section 2.1.2 described the roadways and intersections included within the study area. The study area considered for this TIA Report includes all the traffic-signal controlled intersections within a 400-metre radius from the development (Hunt Club Road/Prince of Wales Drive and Prince of Wales Drive/Deakin Street).

2.2.2 Time Periods

The study provided an analysis of the weekday morning and afternoon peak hours of travel demand which was determined to represent the “worst-case” scenario in terms of weekday commuter traffic conditions.

2.2.3 Horizon Years

The proposed development, at the time of writing is anticipated to be achieved by the end of 2025. A period five-years-after-buildout would then correspond to year 2030.

2.3 EXEMPTION REQUEST

Table 2-11 reflects the exemptions, or reductions in scope, that were requested for the TIA Strategy Report. The only module from the City of Ottawa’s TIA guidelines that were determined to be exempt was Module 4.1.3: New Street Networks, since there are no new streets being proposed as part of the development.

Table 2-11: Exemptions as per TIA Guidelines

Module	Element	Exemption Rationalization / Considerations	Include Module in TIA
<i>Design Review Component</i>			
4.1 Development Design	4.1.3 New Street Networks	There are no new streets being proposed as part of this development.	No
<i>Network Impact Component</i>			
All network Impact Component modules are to be included in the TIA as per City of Ottawa’s request			

3.0 FORECASTING

Section 3.1 of this report was previously submitted to satisfy the Stage 2 (Scoping) requirements on December 18th, 2023 and has been reviewed by the City with comments received on January 8th, 2024.

The remaining sections of this submission represent new information intended to address the Stage 3 (Forecasting) and Stage 4 (Strategy) requirements of the TIA process.

3.1 DEVELOPMENT-GENERATED TRAFFIC DEMAND

Section 1.3 highlighted that, for the purposes of this report, four land uses had been assigned development thresholds based on a maximum or upper development potential that would represent a “worst-case” traffic impact. The land used included:

- An auto dealership with up to 80,000 ft² of gross floor area (GFA),
- A hotel with up to 400 rooms,
- An office building with up to 80,000 ft² of office space, or
- A retail plaza with up to 70,000 ft² of building GFA. (without a supermarket / grocery

Traffic generation estimates have been prepared for each of the alternative land use options. The values (square footage GFA or No. of hotel rooms) of each land use were iteratively determined and represent the worst-case development thresholds for that land use that still would provide traffic options that would not result in a worsening of the existing conditions.

Once the development proponent has selected the desired land use and the actual development potential, it would then be presented for further review by City staff at the time of site plan application.

3.1.1 Trip Generation and Mode Shares

3.1.1.1 Auto Trip Generation Rates

Table 3-1 presents the traffic generation rates that were referenced¹⁶ and Table 3-2 presents the associated vehicle traffic for each alternative land use.

Table 3-1: Summary of Trip Generation Rates by Scenario

Land Use	Source (ITE 11 th Ed.)	Size	Independent Variable	Trip Generation Rate					
				Morning Peak Hour			Afternoon Peak Hour		
				Rate	In	Out	Rate	In	Out
<i>Auto Dealership</i>	<i>Land Use 840</i>	<i>80,000 ft² GFA</i>	<i>1,000 ft² GFA</i>	1.86	73%	27%	2.42	40%	60%
<i>Hotel</i>	<i>Land Use 310</i>	<i>400 Rooms</i>	<i>No. of Rooms</i>	0.46	56%	44%	0.59	51%	49%
<i>Office</i>	<i>Land Use 710</i>	<i>80,000 ft² GFA</i>	<i>1,000 ft² GFA</i>	1.52	88%	12%	1.44	17%	83%
<i>Retail Plaza</i>	<i>Land Use 821</i>	<i>70,000 ft² GFA</i>	<i>1,000 ft² GFA</i>	1.73	62%	38%	5.19	49%	51%

¹⁶ “Trip Generation Manual” (11th Edition) – ITE – Institute of Transportation Engineers

Table 3-2: Summary of Vehicle Trips Generated by Scenario

Land Use	Size	Vehicle Trip Ends					
		Morning Peak Hour			Afternoon Peak Hour		
		In	Out	Total	In	Out	Total
<i>Auto Dealership</i>	<i>80,000 ft² GFA</i>	109	40	149	78	116	194
<i>Hotel</i>	<i>400 Rooms</i>	103	81	184	120	116	236
<i>Office</i>	<i>80,000 ft² GFA</i>	107	15	122	20	95	115
<i>Retail Plaza</i>	<i>70,000 ft² GFA</i>	75	46	121	178	185	363

3.1.1.2 Person Trips and Mode Shares

A comparison of the estimated vehicle traffic generation rates indicated in Table 3-1 with the application of the City of Ottawa’s TIA Guidelines that suggest a vehicle occupancy factor of 1.28-person trips-to-vehicle trips (average auto occupancy) was used to convert vehicle-trips to person-trips.

Table 3-3: Existing Mode Shares

Mode	Mode Share, Employment Generators	Mode Share, Commercial Generators, AM	Mode Share, Commercial Generators, PM
<i>Auto-Driver</i>	70%	71%	61%
<i>Auto-Passenger</i>	7%	19%	16%
<i>Transit</i>	16%	1%	8%
<i>Cycling</i>	3%	0%	1%
<i>Walking</i>	4%	9%	14%

The 2020 TRANS Trip Generation Manual¹⁷ was referenced to provide an estimate of mode share applicable to the “Merivale Area” which indicated a 60-to-70% peak hour auto-driver mode share.

The following bullets highlight the adopted mode-share for each alternative land which were assumed to be identical for each of the non-residential land uses:

- 78% Auto-driver;
- 15% Auto Passenger;
- 5% Transit;
- 2% Active Transportation (walking + cycling).

The 78% auto-driver mode share is roughly 10% higher than the predicted 70% share indicated in the TRANS Trip Generation Manual for employment and commercial generators¹⁷. This resulted in a conservative worst-case approach when assessing the impacts of vehicle traffic operational impacts upon the surrounding roadways. It was appreciated that the suggested auto-driver mode shares within the TRANS document reflects a “peak period” share which is likely lower than the mode share that would occur during the “peak hour” of travel demand.

¹⁷ TRANS Trip Generation Manual – Summary Report, City of Ottawa, WSP, October 2020, Table 12 and Table 13

Table 3-4: Summary of Person Trips Generated in Each Land Use Scenario by Mode

Land Use	Mode	Share	Trip Ends					
			Morning Peak Hour			Afternoon Peak Hour		
			In	Out	Total	In	Out	Total
Auto Dealership 80,000 ft ² GFA	Auto-Driver	78%	109	40	149	78	116	194
	Auto-Passenger	15%	21	8	29	15	22	37
	Transit	5%	7	3	10	5	7	12
	Active Transportation	2%	3	0	3	2	3	5
	Total	100%	140	51	191	100	148	248
Hotel 400 Rooms	Auto-Driver	78%	103	81	184	120	116	236
	Auto-Passenger	15%	20	15	35	23	22	45
	Transit	5%	7	5	12	8	7	15
	Active Transportation	2%	2	3	5	3	3	6
	Total	100%	132	104	236	154	148	302
Office 80,000 ft ² GFA	Auto-Driver	78%	107	15	122	20	95	115
	Auto-Passenger	15%	21	2	23	4	18	22
	Transit	5%	7	1	8	1	6	7
	Active Transportation	2%	2	1	3	1	2	3
	Total	100%	137	19	156	26	121	147
Retail Plaza 70,000 ft ² GFA	Auto-Driver	78%	75	46	121	178	185	363
	Auto-Passenger	15%	14	9	23	34	36	70
	Transit	5%	5	3	8	11	12	23
	Active Transportation	2%	2	1	3	5	4	9
	Total	100%	96	59	155	228	237	465

3.1.2 Trip Distribution

Exhibit 3-1 illustrates the traffic distribution trends associated with the existing Myers dealership located on Baseline Road.

It was therefore determined that:

- 33% of the traffic was assumed to originate from, or be destined to, south of the site along Prince of Wales Drive.
- Traffic distribution at the Prince of Wales Drive / Deakin Street intersection is based on the existing traffic split at the intersection; and
- 67% of the traffic was forecast to originate from, or be destined to, north of the site along Prince of Wales Drive, and Hunt Club Road.

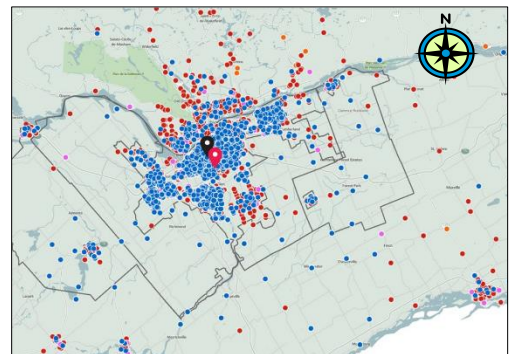

Exhibit 3-1: Myers Customer Mapping

Traffic distribution at the Hunt Club Road / Prince of Wales Drive intersection was based on the existing traffic proportions occurring at the intersection.

Table 3-5 presents the resulting traffic distribution trends to, and from, the proposed development.

Table 3-5: Summary of Forecasted Trip Distribution

North-South Trip Distribution on Prince of Wales Drive		Distribution	Morning Peak Hour		Afternoon Peak Hour	
			Inbound Trips (Originating from...)	Outbound Trips (Destined to...)	Inbound Trips (Originating from...)	Outbound Trips (Destined to...)
Northbound	67%	West on Hunt Club Road	1%	3%	3%	2%
		East on Hunt Club Road	37%	36%	28%	41%
		North on Prince of Wales	29%	28%	36%	24%
Southbound	33%	South on Prince of Wales	24%	20%	21%	29%
		West on Deakin Street	9%	13%	12%	4%
Total	100%		100%	100%	100%	100%

3.1.2.1 Traffic Distribution by Access

As illustrated on the following exhibits and Appendix “D”, access to/from the development would be provided by the following two accesses to/from Prince of Wales Drive:

- A more northerly right-in right-out access; and
- A more southerly access that would permits right-in, right-out and southbound left turns in. (Left turns out of the site would be prohibited.)
- The City of Ottawa had indicated a preference for right-in, right-out accesses along the Prince of Wales Drive corridor. However, given that 67% of the traffic headed into the proposed development (Exhibit 3-1 illustrates the existing auto dealership’s customer addresses.) would originate from the north, there is a significant need to accommodate left turns into the site from the north providing entry via the south access. It should be kept in mind that inbound traffic making a U-turn at the Deakin Street intersection was considered more disruptive to north-south thru movements than providing for a properly designed southbound left-turn lane. In addition, for a site of this size (3.23 hectares with 65% of the area developable), a minimum of two accesses are necessary to assure project viability.

Table 3-6 summarizes the forecast traffic distribution trends by access.

Table 3-6: Trip Distribution by Access

Inbound Traffic		Outbound Traffic	
South Access Left-in	67%	South Access Right-out	40%
South Access Right-in	20%		
North Access Right-in	13%	North Access Right-out	60%
Total Inbound	100%	Total Outbound	100%

3.1.3 Trip Assignment

Table 3-7 summarizes and the following exhibits illustrate the traffic generated by each of the four potential land use concepts currently considered for the subject site’s development.

Table 3-7: Summary of Vehicle Trips Generated by Scenario and Relevant Exhibits

Land Use	Size	Exhibit Number	Trip Ends					
			Morning Peak Hour			Afternoon Peak Hour		
			In	Out	Total	In	Out	Total
<i>Auto Dealership</i>	<i>80,000 ft² GFA</i>	Exhibit 3-2	109	40	149	78	116	194
<i>Hotel</i>	<i>400 Rooms</i>	Exhibit 3-3	103	81	184	120	116	236
<i>Office</i>	<i>80,000 ft² GFA</i>	Exhibit 3-4	107	15	122	20	95	115
<i>Retail Plaza</i>	<i>70,000 ft² GFA</i>	Exhibit 3-5	75	46	121	178	185	363

3.1.4 Resulting Site Generated Traffic Volumes

Exhibit 3-2 through Exhibit 3-5 illustrate the vehicle traffic volumes that would be generated by each of the four alternative land uses being considered for the site.

- Exhibit 3-2 illustrates the site generated traffic associated with a 80,000 SF auto dealership.
- Exhibit 3-3 illustrates the site generated traffic associated with a 400 room hotel.
- Exhibit 3-4 illustrates the site generated traffic associated with an 80,000 SF office.
- Exhibit 3-5 illustrates the site generated traffic associated with an 70,000 SF retail plaza (excluding a supermarket / grocery store or drive-thru fast food restaurant-type land use.)

3.1.5 The TIA Report and Application for a Zoning Amendment

It is understood that this TIA, after review and suggestions by City Staff, is to be sufficient to permit application for a zoning amendment that would permit an auto dealership, hotel, office or retail plaza land use to be added to the list of permitted uses.

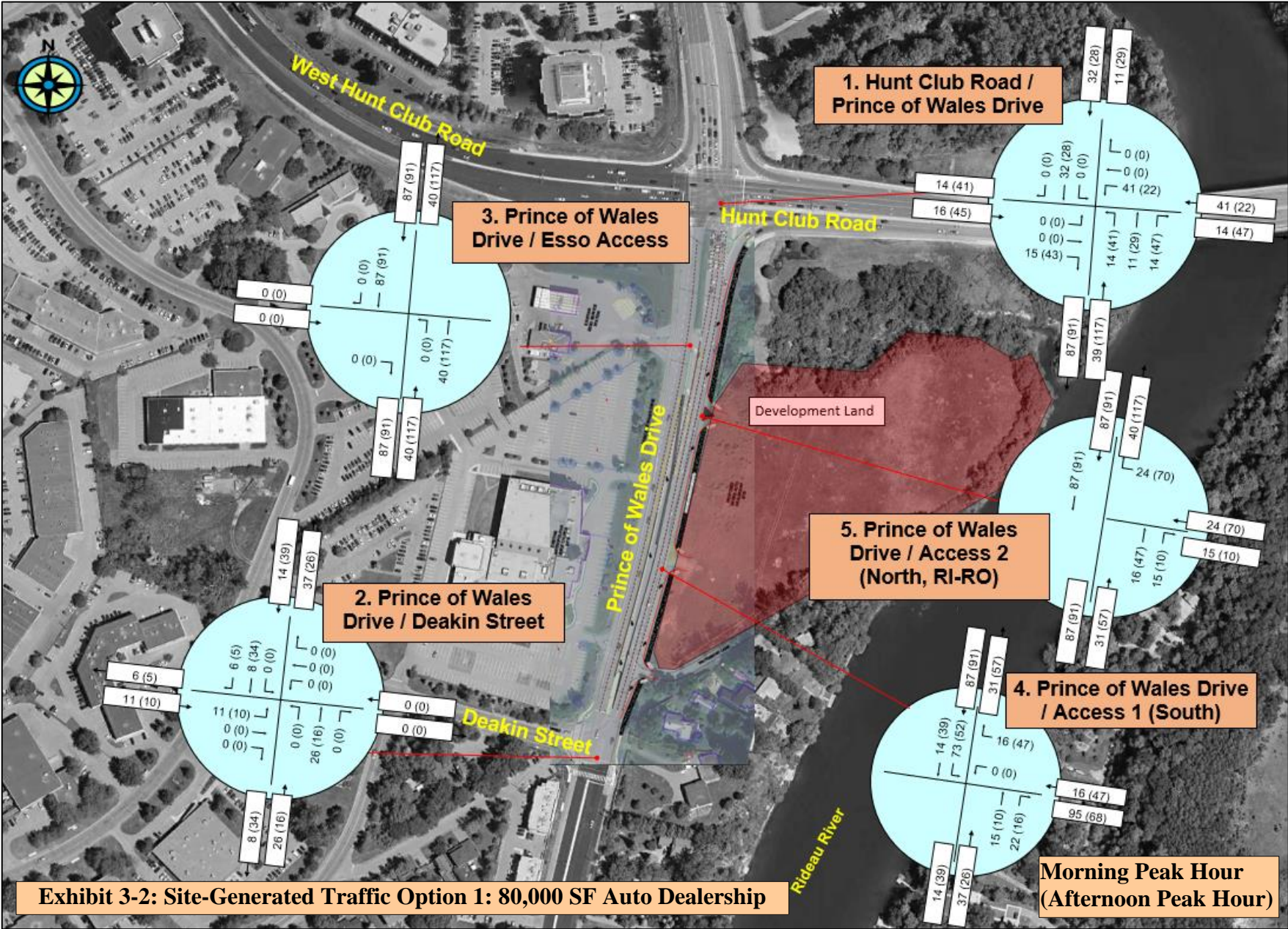

Exhibit 3-2: Site-Generated Traffic Option 1: 80,000 SF Auto Dealership

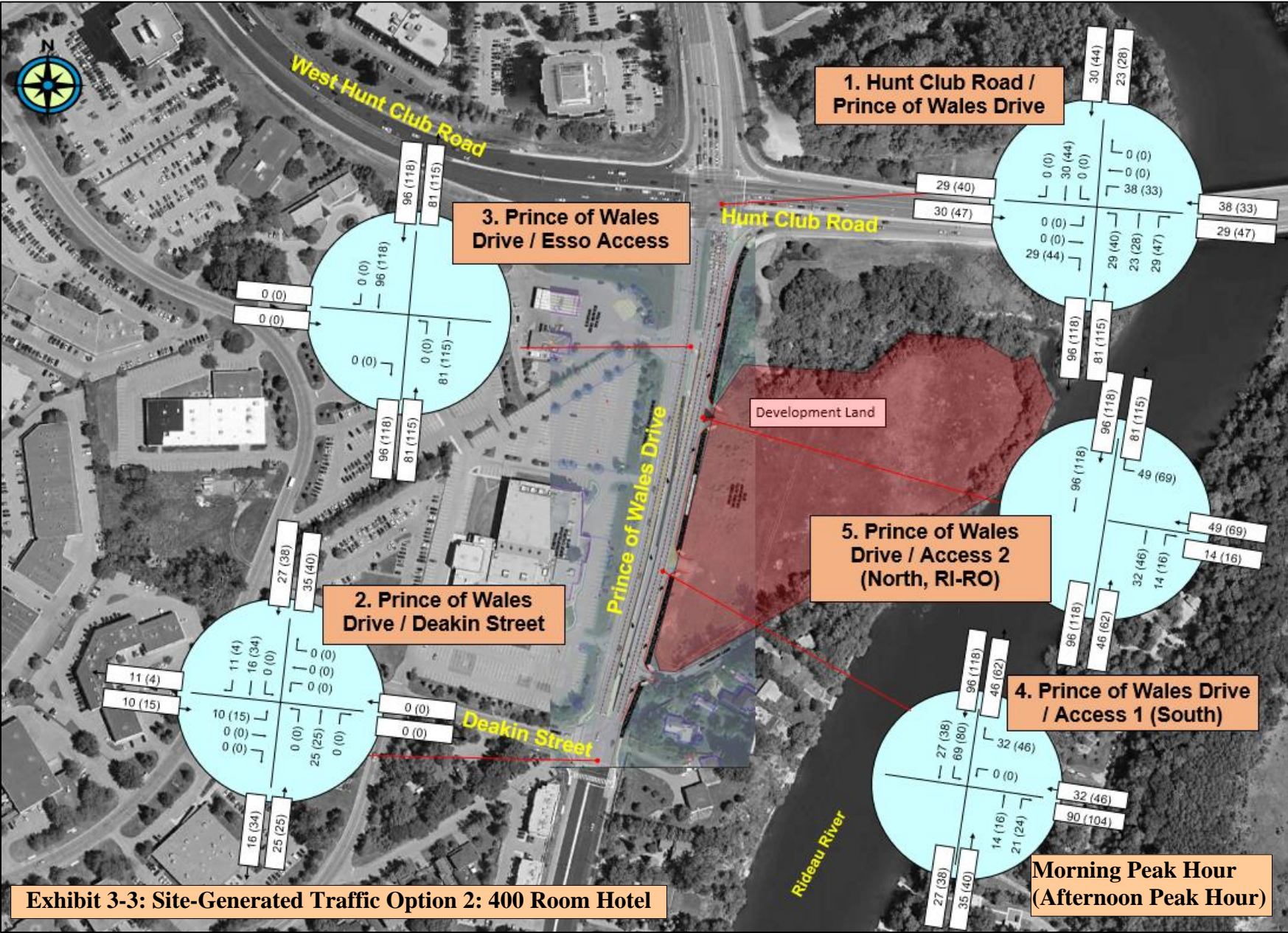

Exhibit 3-3: Site-Generated Traffic Option 2: 400 Room Hotel

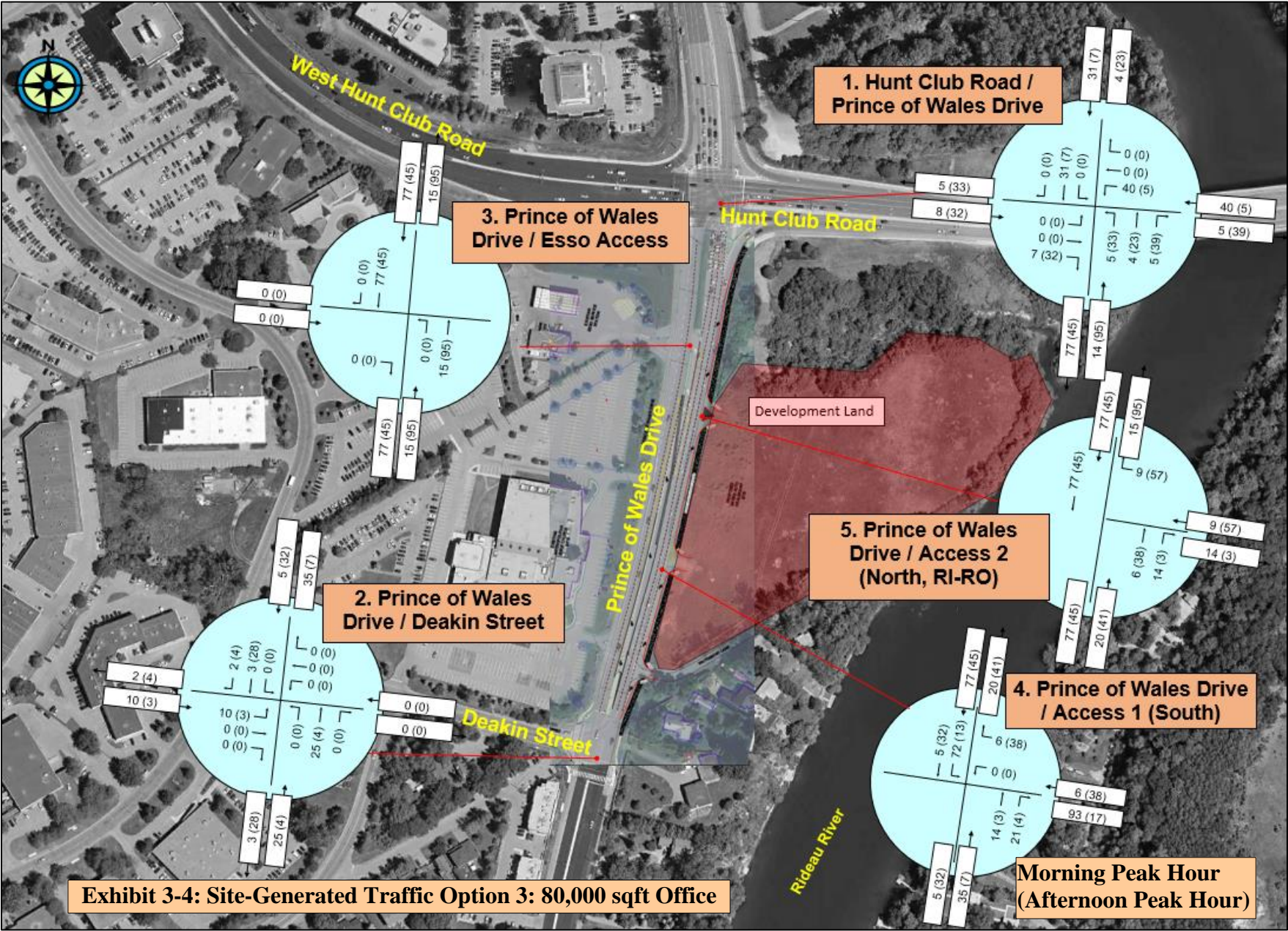
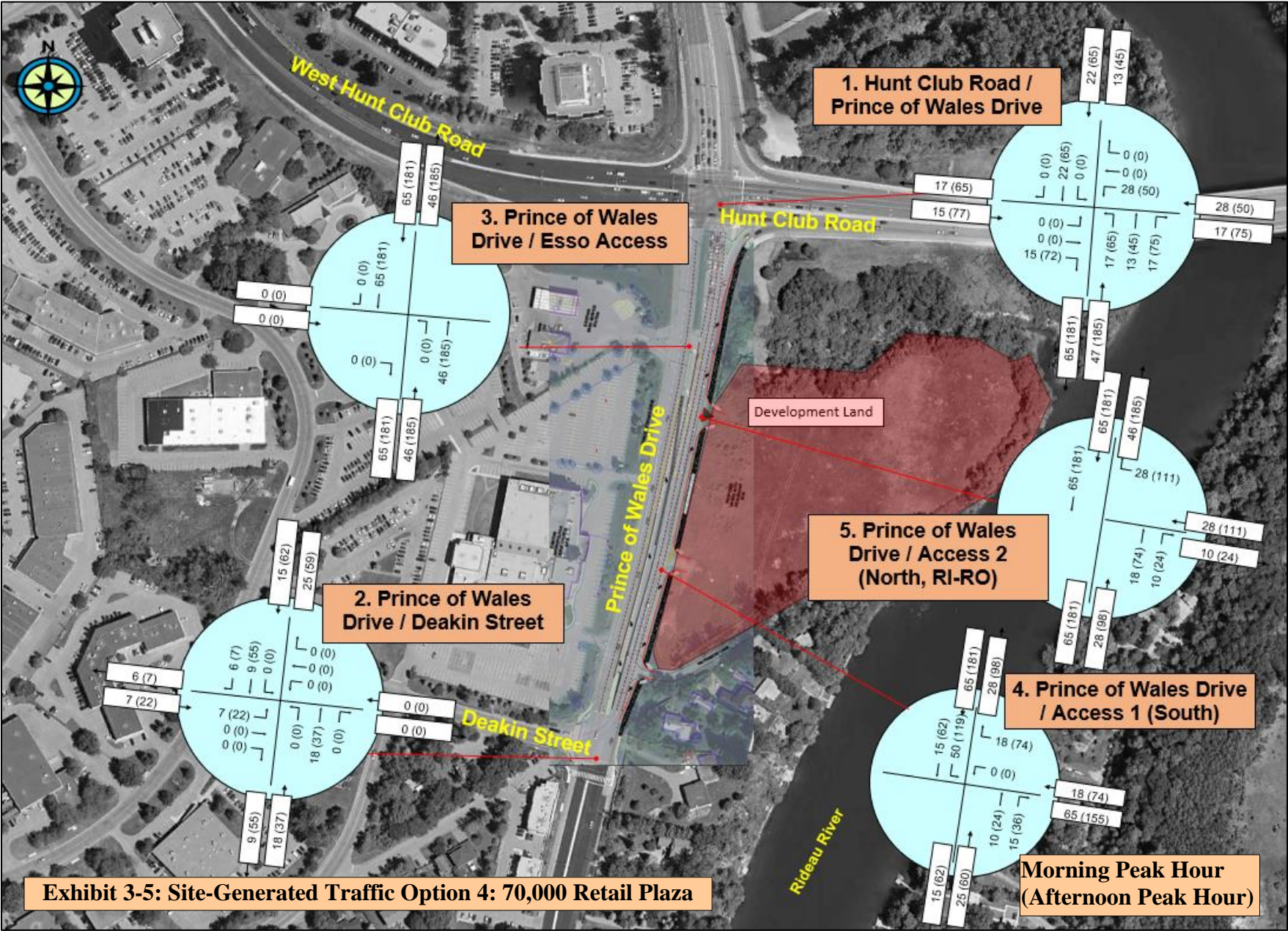

Exhibit 3-4: Site-Generated Traffic Option 3: 80,000 sqft Office



3.2 BACKGROUND NETWORK TRAVEL DEMAND

3.2.1 Transportation Network Plans

Refer to Section 2.1.3.1 for the future transportation network plans in the study area.

3.2.2 Background Growth

A background traffic growth rate of 0.5% was used to account for traffic growth that could occur within the study area.

3.2.3 Other Identified Developments

Section 2.1.3.2 describe the identified 3930-3960 Riverside Drive, and 2009-2013 Prince of Wales Drive residential developments. The traffic generated by these developments were felt to be accounted for within the 0.5% background growth rate applied to the study area intersections.

3.2.4 Background Traffic Forecasts and Analysis

It is understood that the Prince of Wales Drive / Hunt Club Road intersection is currently operating at capacity (See Section 2.1.2.8) and this represents an existing condition.

The following exhibits illustrate the additional effects of background traffic (assuming the proposed development is not in place) for the selected horizon years:

- Exhibit 3-6 illustrates the background traffic forecast for an assumed 2025 (build-out) horizon.
- Exhibit 3-7 illustrates the background traffic forecast assuming a 2030 (build-out + 5 years) horizon.

Table 3-8 provides the results of background traffic analysis for both the 2025 (build-out) and 2030 (Build-out + 5 years) horizons [Appendix “E” provides the Synchro intersection capacity analysis output sheets.]. The table indicates:

- *Hunt Club Road and Prince of Wales Drive Intersections:* Overall, the intersection of continues to operate at capacity and exhibit failing operational performance for the critical NB-RT and WB-LT movements. Some improvement in operational performance over the existing conditions for some of the movements was noted but this was attributed to the application of a 1.0 PHF (Peak Hour Factor) as per City of Ottawa’s TIA Guidelines for future conditions analysis (0.9 PHF was used for existing analysis)¹⁸.
- *Prince of Wales Drive and Deakin Street Intersection:* The Eastbound left turn from Deakin Street onto Prince of Wales Drive will exhibit a level of service “E” with a delay of 65 seconds and a v/c ratio of 0.92 in the 2030 horizon year, even without the proposed development.

18. City of Ottawa TIA Guidelines, Appendix C – Synchro Analysis Parameters, Page 76

Table 3-8: Background (2025 and 2030) Traffic Analysis
[Assumes Development is NOT in Place]

Intersection	Control Type	Weekday Morning Peak Hour (Afternoon Peak Hour)				
		Critical Movement	95 th Percentile Queue (m)	Delay (seconds)	v/c Ratio	LOS
Background 2025						
1. Hunt Club Road and Prince of Wales Drive	Traffic Signal	NB-LT	31 (18)	77.1 (87.1)	0.54 (0.41)	A (A)
		NB-TH	115 (88)	56.8 (75.9)	0.82 (0.84)	D (D)
		NB-RT	354 (317)	257.6 (325)	1.49 (1.64)	F (F)
		EB-RT	0 (0)	0 (0.2)	0.02 (0.08)	A (A)
		SB-TH	62 (147)	41.7 (57.1)	0.42 (0.81)	A (D)
2. Prince of Wales Drive and Deakin Street	Traffic Signal	WB-LT	111 (146)	118.8 (198.6)	1.08 (1.30)	F (F)
		SB-TH	41 (110)	6.2 (12.9)	0.44 (0.68)	A (B)
		NB-TH	86 (43)	11 (8.7)	0.55 (0.34)	A (A)
3. Prince of Wales Drive and Esso Service Station Access	Assumed Minor Leg-STOP	EB-LT	58 (96)	43.9 (62.3)	0.76 (0.92)	C (E)
		EB-RT	6 (4)	16.2 (19.9)	0.22 (0.13)	A (A)
		NB-LT	1 (1)	14.6 (22.1)	0.04 (0.03)	A (A)
Background 2030						
1. Hunt Club Road and Prince of Wales Drive	Traffic Signal	NB-LT	31 (19)	77.4 (88.0)	0.54 (0.42)	A (A)
		NB-TH	118 (92)	58.1 (77.9)	0.84 (0.86)	D (D)
		NB-RT	367 (327)	274.7 (342.7)	1.53 (1.68)	F (F)
		EB-RT	0 (0)	0 (0.2)	0.02 (0.08)	A (A)
		SB-TH	64 (153)	42.0 (58.2)	0.43 (0.83)	A (D)
2. Prince of Wales Drive and Deakin Street	Traffic Signal	WB-LT	114 (150)	126.6 (210.8)	1.11 (1.33)	F (F)
		SB-TH	43 (115)	6.5 (13.4)	0.45 (0.68)	A (B)
		NB-TH	89 (45)	11.4 (8.8)	0.57 (0.35)	A (A)
3. Prince of Wales Drive and Esso Service Station Access	Assumed Minor Leg-STOP	EB-LT	59 (100)	44.0 (64.6)	0.76 (0.92)	C (E)
		EB-RT	6 (4)	16.4 (19.9)	0.22 (0.13)	A (A)
		NB-LT	1 (1)	14.8 (22.1)	0.04 (0.03)	A (A)

Analysis was undertaken using Synchro™ V11 traffic analysis software. See Appendix "E" for Synchro analysis output sheets.

Assumed 2025 and 2030 Forecast traffic volumes. See Exhibit 3-6 and Exhibit 3-7.

Analysis was carried using the traffic-signal timings phasing that were provided by the City of Ottawa. See Appendix "B".

Analysis assumes a peak hour factor (PHF) of 1.00.

Values outside of Brackets represent Morning Peak Hour Values.

Values inside of Brackets represent Afternoon Peak Hour Values.

Values that are in Bold indicate unsatisfactory results / parameters.

Movements that are forecast to be affected by the proposed development's traffic are shown

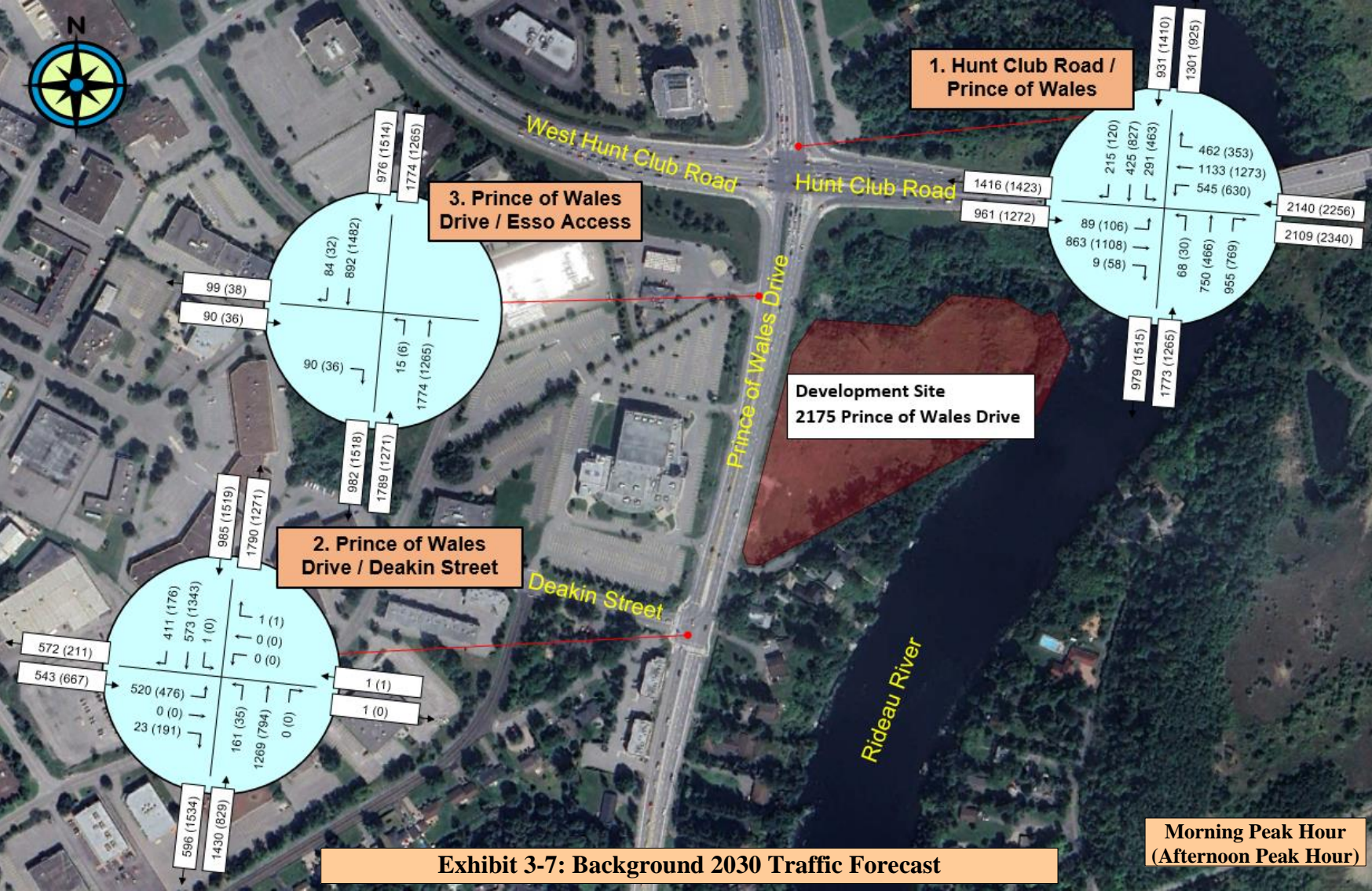

3.3 DEMAND RATIONALIZATION

The existing 2023 traffic analysis, (See Section 2.1.2.8, Exhibit 2-14 and Table 2-7) along with background traffic analysis impacts estimated to occur in 2025 & 2030 (See Section 3.2.4 Exhibit 3-6, Exhibit 3-7 and Table 3-8) indicate that there is an existing capacity constraint at Hunt Club Road / Prince of Wales Drive intersection, which is forecast to continue in future horizon years even without the proposed development in place.

It is understood that the intersections on either side of the Hunt Club Road bridge operate in sync with one another at their maximum capacity with traffic signal cycle-lengths of between 140-to-150 seconds of duration. It is unlikely that any further signal optimization could resolve the capacity constraint.

Possible solutions to the capacity constraints could be to:

- decrease the auto-driver mode share in favor of transit or active transportation modes.
- decrease peak hour demands by encouraging hybrid and remote work options.
- arrange for staggered work arrival times that would spread out peak hour traffic demands over a longer period of time.

3.3.1 Total Travel Demand

Total travel demand traffic forecasts, along with traffic analysis are provided and presented in Section 4.9.2.

4.0 STRATEGY

The development application for 2175 Prince of Wales Drive intends to seek a Zoning By-Law Amendment permitting a variety of uses such as an auto dealership, hotel, office or retail plaza.

At this stage, the proponent has not provided a final land use, or a detailed site plan for the development but still wishes to amend the zoning by-law to permit the desired uses. As such, there are certain limitations to the scope of this Strategy Report, that cannot address details such as on-site circulation, parking, and TDM measures that cannot be evaluated or assessed at this time. Rather, this document focuses on requirements set out by the City of Ottawa regarding the above items, as well as recommendations to the development proponent to achieve the desired mode share targets.

4.1 DEVELOPMENT DESIGN

The Development Design section of the City of Ottawa's TIA guidelines is intended to assess the design of the transportation facilities provided within the proposed development's site plan. However, since there is no site plan and the proponent has yet to select a final land use option, this section will focus on recommendations oriented at increasing the sustainable mode share targets.

4.1.1 Design for Sustainable Modes

Appendix "F" provides City of Ottawa TDM-Supportive Development Design and Infrastructure checklist for the site. The proponent has been advised to review the TDM measures checklist, ensure all required measures applicable to each land use is implemented, and strongly consider implementing "basic" and "better" TDM measures as outlined in the checklist at the Site Plan Control stage.

4.1.2 Circulation and Access

Out of the four considered land uses, an 80,000 SF auto dealership was chosen as the critical case for circulation analysis. This land use represents a worst-case in relation to the required size of the design vehicle that must be accommodated on site and within the on-road turning lanes and accesses points. Exhibit 4-1 illustrates the dimensions of a 25m long typical car carrier truck which delivers vehicles to such a dealership. Given the heavy traffic volumes along Prince of Wales Drive, it is not advisable for this site to permit curbside car carrier off-loading.

Appendix "G" provides turning movement diagrams and access layouts for the 25m long car carrier vehicle illustrating the potential impacts to the access designs. This design vehicle naturally requires wider accesses and circulation room through the site that would necessitate entry by way of Access 1 (the south access) and exit via Access 2 (the north access). Internal circulation patterns into/out of and through the site will be required at the time of site plan application.

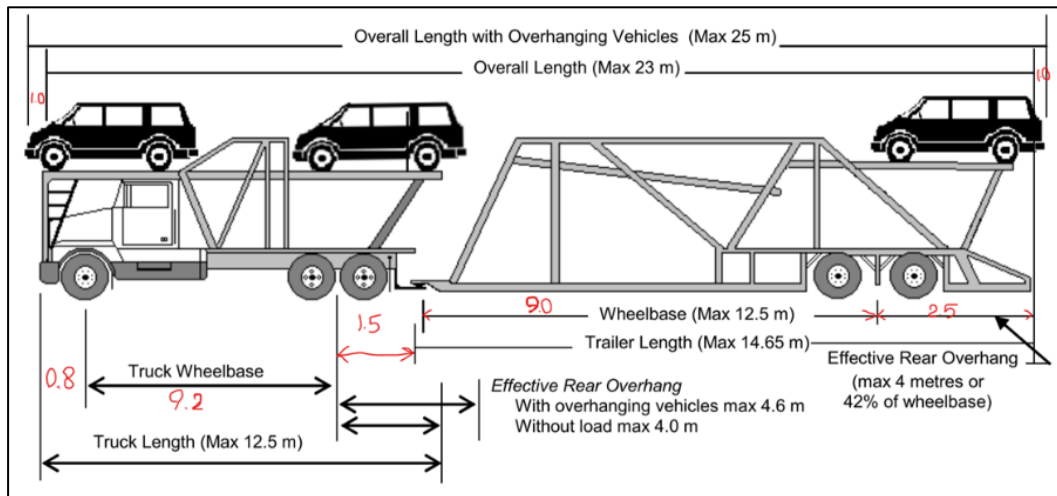

Exhibit 4-1: 25m long Car Carrier Design Vehicle: Geometric Attributes

The Car Dealership land use represents the “worst-case” land use as regards the resulting required site access widths due to the prohibition of on-street loading/unloading on the adjacent boundary streets and the requirement needed to permit this vehicle to circulate through the site.

4.2 PARKING

The following section discusses required parking provisions for the proposed development options. Given that a detailed site plan for each of the alternative land uses is not available, this section outlines the requirements from the City of Ottawa’s parking by-law¹⁹, however information regarding the parking that would be provided for each alternative land use is not available (since the parking provisions of each site plan option are unknown at the time).

Parking provisions for the preferred land use will be required at the time of site plan application.

4.2.1 Parking Requirements

4.2.1.1 Vehicle Parking

Table 4-1 summarizes vehicle parking provisions required for each of the four considered land uses. The development area is located within “Area C: Suburban” for the purpose of establishing minimum parking space rate calculations²⁰

19. City of Ottawa By-Law 2018-206, Table 101

20. Schedule A to Zoning By-law No. 2008-250. Table 101

Table 4-1: Parking Requirements

Alternative Land Use	Land Use per Table 101	Size (up to..)	Vehicle Parking Rate	Parking Required	Comment
Auto Dealership	N10 – Automobile Dealership	80,000 sqft (7,432 m ²)	<ul style="list-style-type: none"> -Sales/showroom area, 2 per 100 m² of gross floor area. -Service area, 2 per service bay. -Other areas, 1 per 100 m² of gross floor area. 	Up to 149 parking stalls	This is subject to further review at the SPA stage.
Hotel	N44 - Hotel	400 rooms (guest units)	<ul style="list-style-type: none"> 1 per guest unit. 	Up to 400 parking stalls	Parking rate for restaurant use, should it be present on-site, would be calculated separately.
Office	N59 - Office	80,000 sqft (7,432 m ²)	<ul style="list-style-type: none"> 2.4 per 100 m² of gross floor area. 	Up to 179 parking stalls	
Retail Plaza	N83 – Shopping Centre	70,000 sqft (6,503 m ²)	<ul style="list-style-type: none"> 3.6 per 100 m² of gross leasable floor area. 	Up to 235 parking stalls	Assuming the maximum gross leasable area of 70,000 SF (6,503 m ²). This would be subject to further review at the SPA Stage.

4.2.1.2 Bicycle Parking

Table 4-2 summarizes bicycle parking requirements for each of the four alternative land uses. Larger than required number of bicycle stalls can help promote a more sustainable mode share choice for the development’s trip generation.

Table 4-2: Bicycle Parking Requirements

Alternative Land Use	Land Use per Table 111A	Size (up to..)	Bicycle Parking Rate	Parking Required	Comment
Auto Dealership	(i) all other non-residential uses	80,000 sqft (7,432 m ²)	1 per 1,500 m ² of gross floor area	Up to 5 bicycle parking stalls	
Hotel	(g) airport; bus station; hospital; hotel ; light industrial use; medical facility; technology industry; train station	400 rooms (guest units). [assuming 400 sqft / room + 40,000 sqft for common areas and etc. = 200,000 sqft (18581 m ²)	1 per 1,000 m ² of gross floor area	Up to 19 bicycle parking stalls	To be revised at the Site Plan Control stage given updated gross floor area.
Office	(e) bank; convenience store; day care; office ; post office; post secondary educational institution; restaurant; retail food store; retail store	80,000 sqft (7,432 m ²)	1 per 250 m ² of gross floor area	Up to 30 bicycle stalls	
Retail Plaza	(f) library; municipal service centre; personal service business; retail food store 8,000 m ² of gross floor area or greater; retail store 8,000 m ² of gross floor area or greater; service or repair shop; shopping centre	70,000 sqft (6,503 m ²)	1 per 500 m ² of gross floor area	Up to 14 bicycle stalls	

4.3 BOUNDARY STREETS

The following section discusses the impacts of the proposed development on boundary streets (Prince of Wales Drive and Hunt Club Road).

4.3.1 Prince of Wales Widening ESR

The 2011 Prince of Wales Widening ESR²¹ had proposed a design for the Prince of Wales corridor, that addresses the area fronting the proposed development. The document was reviewed prior to developing the proposed access arrangement.

4.3.2 Mobility

The City of Ottawa’s Multi-Modal Level of Service Guidelines²² along with the MMLOS addendum²³ were referenced to evaluate the multi-modal operational characteristics of the roadway segments in the vicinity of the proposed development.

Table 4-3 outlines the values of the existing level of service and target levels of service for various non-auto-driver transportation modes in the city:

- Pedestrian Level of Service (PLOS);
- Bicycle Level of Service (BLOS);
- Transit Level of Service (TLOS); and
- Truck Level of Service (TkLOS).

The Multi-Modal Level of Service analysis focuses on roadway segments adjacent to the development which include the Hunt Club Road West and Prince of Wales Drive corridors.

Table 4-3: Segment MMLOS Analysis Results

Location		Level of Service and Targets							
	Level of Service	PLOS		BLOS		TLOS		TkLOS	
Roadway Segment	Policy Area/ Land Use Designation	Existing	Target	Existing	Target	Existing	Target	Existing	Target
Hunt Club Road	General Urban Area	E	C	E	C	D	D	A	D
Prince of Wales Drive		F	C	C	B	E	D	C	D

Note – Levels of Service highlighted in bold font fail to meet the respective target LOS

21. Prince of Wales Drive Widening Fisher Avenue to Woodroffe Avenue Environmental Study Report – Volume I. Morrison Hershfield, October 2011. Page 261, drawing 23 and 24

22. Multi-Modal Level of Service (MMLOS) Guidelines, IBI Group, September 2015

23. Document 5: Addendum to the City’s Multi-Modal Level of Service Guidelines, December 2016

The Hunt Club Road boundary segment is characterized by a 1.5-metre-wide sidewalk and a 1.5-metre boulevard in the vicinity of the proposed development, earning it a PLOS of “E”.

The Prince of Wales Drive boundary segment fronting the development has no sidewalks along the frontage which results in a PLOS of “F”.

Mitigations: to achieve the satisfactory PLOS “C”, the following mitigations could be considered:

*Pedestrian
Level of Service
(PLOS):*

- Maximum achievable PLOS while maintaining an operating speed of over 60 km/hr along the roadways is “D”. Therefore,
 - Along Hunt Club Road, a reduction in posted speed limit to 60 km/hr, along with a widening of the boulevard to over 2 metres would be required to meet the required PLOS “C”;
 - Along Prince of Wales Drive, a sidewalk with a boulevard width of over 2 metres would have to be instated, which would net the segment a PLOS “C”

Bicycle lanes are provided along both Hunt Club Road and Prince of Wales Drive. However, the operating speed along Prince of Wales Drive is 60 km/hr (60 km/hr posted) and along Hunt Club Road it is 80 km/hr (80 km/hr posted). Operating speeds of 60 km/hr nets Prince of Wales Drive a BLOS “C” and operating speed of over 70 km/hr nets Hunt Club Road a BLOS “E”.

Prince of Wales drive, being a Cross-Town Bikeway, has a target BLOS “B”, while Hunt Club Road, being a spine route arterial, has a target BLOS “C”.

Mitigations: to achieve the satisfactory BLOS “C” along Hunt Club Road, the following mitigations could be considered:

*Bicycle Level of
Service (BLOS):*

- Reduction in operating (posted) speed to 60 km/hr, which would net the segment a PLOS “C”, or
- A physically-separated bikeway, which would result in BLOS “A”.

Mitigations: to achieve the satisfactory BLOS “B” along Prince of Wales Drive, the following mitigations could be considered:

- Reduction in operating (posted) speed to 50 km/hr (or lower), or
- A physically-separated bikeway;
- Either of the above options would result in BLOS “A”. It is understood that providing a physically-separated bikeway along Prince of Wales is preferred.

<i>Transit Level of Service (TLOS):</i>	Both Prince of Wales Drive and Hunt Club Road experience significant levels of congestion during the peak hours of travel demand. The congestion along Prince of Wales Drive is exacerbated by higher driveway friction earning it a TLOS of “E” while the Hunt Club Road West corridor earned a TLOS of “D”. There is presently no transit service along Prince of Wales Drive between Hunt Club Road and Deakin Street.
<i>Truck Level of Service (TkLOS):</i>	Both roadways were found to meet their target for TkLOS, as they provide for more than two travel lanes, however the travel lanes along Prince of Wales Drive narrows down to around 3.3 metres in width, earning it a TkLOS “C”, while Hunt Club Road exhibits a TkLOS of “A” which was attributed to the wider travel lanes. No further

4.3.3 Road Safety

A comprehensive review of available collision information is provided within Section 2.1.2.9 [Existing Road Safety Information](#).

4.3.4 Neighbourhood Traffic Management

Traffic management measures are not anticipated to be required.

4.4 ACCESS INTERSECTIONS

4.4.1 Location and Design of Accesses

As per City of Ottawa’s revisions to the TIA Guidelines effective June 2023²⁴, this module is discussed within Section 4.9.3.

4.4.2 Access Control

As indicated within Section 1.5, two access driveways are proposed for the 2175 Prince of Wales Drive development. These include:

- A proposed south access (which prohibits left turns out of the site) is located less than 150 metres from Prince of Wales Drive/Deakin Street intersection, and
- A proposed north right-in/right-out only access is less than 150 metres from the Hunt Club Road/Prince of Wales Drive intersection.

The accesses arrangement was evaluated accounting for:

- the existing traffic volumes along Prince of Wales Drive,
- the forecast traffic volumes along Prince of Wales Drive,
- the existing roadway geometry (number of lanes),
- the proposed roadway geometry as detailed within the Prince of Wales Widening ESR²⁵,

²⁴ *Revisions to Transportation Impact Assessment Guidelines*, Dillon Consulting, effective June 14, 2023

²⁵ *“Prince of Wales Drive Widening Fisher Avenue to Woodroffe Avenue Environmental Study Report”* – Volume I. Morrison Hershfield, October 2011. Page 261, drawing 23 and 24

- the proximity to other signalized intersections,
- the 184m / 600 ft long frontage,
- the desire to minimize left turn movements into and out of the proposed site,
- the need to accommodate a minimum of 2 accesses into the site to provide a circular route internal to the site, and
- The need to minimize disruption to the adjacent residents living on Waterbend Lane.

Both development accesses would operate as minor leg STOP-controlled intersections. The idea of developing full movement intersections such as roundabouts or signalized intersections that would provide access to the site was considered unworkable due to the amount of property that would be required and the proximity to adjacent intersections.

4.4.3 The Proposed Accesses and the Future Multi-Use Pathway

Approximately 65% of the 8-acre site is developable and two accesses are required to assure functionality since on-street vehicle unloading/loading of car carrier vehicles would be discouraged on Prince of Wales Drive, provision must be made for large car carrier vehicles to navigate and circulate through the site which necessitates one access to be used for entry and another for exit to assure project viability.

Consolidation of the two accesses for a site this size to a single access will jeopardize the auto dealership land use for this project.

The Prince of Wales Drive EA proposed a multi-use pathway envisioned along the east side of the Prince of Wales Drive corridor. At the time of functional planning, access designs are to incorporate the most current City of Ottawa design standards aimed at assuring both pedestrian and cyclist safety.

4.4.4 Intersection Design

Appendix “D” provides the proposed concept design for the Prince of Wales corridor illustrating the following accesses:

- *Access 1:* This is the more southerly access that would permits right-in, right-out and southbound left turns in. (Left turns out of the site would be prohibited.) The access is located roughly 70m to the north of Waterbend Lane.
- *Access 2:* The more northerly access would be constrained to right-in right-out only access located roughly 100m north of Access 1, and 120 m south of the Hunt Club Road West STOP bar.

Please refer to Section 4.9.2 for detailed review of access operations, including operational performance analysis.

4.5 TRANSPORTATION DEMAND MANAGEMENT

This section of the report identifies applicable post-occupancy TDM measures, as outlined in the City of Ottawa’s TIA Guidelines and TDM Measures Checklist (See Appendix “H”).

4.5.1 Context for TDM

The proposed auto-driver mode share (78%) was considered to be higher than the existing mode shares in the Merivale area. This was thought to represent a conservative “worst-case” approach to forecasting the impact of auto trips destined to, and leaving, the proposed development. This approach was used for the purposes of determining the upper threshold of traffic into, and out of, the development that the site accesses could support, given the existing and forecast traffic volumes on the surrounding network.

Relevant TDM measures, active transportation infrastructure upgrades, and improvements in transit service within the study area can, if successfully implemented, result in a lower auto-driver mode share.

4.5.2 Need and Opportunity

Applicable TDM measures, should they be implemented, will aid in reducing adjacent street peak hour demands. Providing more convenient travel options to, and from, the development and can also help to increase patronage (particularly in case of retail plaza), and/or enhance convenience for employees (particularly in case of office building development).

4.5.3 TDM Program

A preliminary review of the City of Ottawa’s TDM Measures checklist indicated that the following TDM (Transportation Demand Management) measures are applicable for this development, regardless of the preferred land use that would go forward for site plan application. This will be substantiated along with any additional development specific TDM Measures at the time of site plan application.

- designate an internal coordinator, or contract with an external coordinator,
- display local area maps with walking/cycling access routes and key destinations at major entrances,
- display relevant transit schedules and route maps at entrances,
- provide a dedicated ride-matching portal such as OttawaRideMatch.com,
- provide a multi-modal travel option information package to new/relocating employees or patrons.

4.6 NEIGHBOURHOOD TRAFFIC CALMING

The City of Ottawa’s revisions to the TIA Guidelines²⁶ (effective June 2023, Neighborhood Traffic Calming measures) would be reviewed. A review of Table 4-4 indicates that only 2 out of 5 triggers are met, therefore neighbourhood traffic calming measures are not applicable for this development.

Table 4-4: Neighbourhood Traffic Calming Criteria

#	Criteria	Additional Criteria	Triggered?
1.	Access to Collector or Local		No (Access directly to Prince of Wales is proposed).
2.	“Significant sensitive land use presence” exists, where there is <u>at least two</u> of the following adjacent to the subject street segment:	School	<i>Not present</i>
		Park	<i>Not present</i>
		Retirement / Older Adult Facility	<i>Not present</i>
		Licensed Child Care Centre	<i>Present - Little Explorers Reggio Emilia Pre-School, 6 Deakin St. is adjacent to Prince of Wales corridor</i>
		Community Centre	<i>Not present</i>
		50%, or greater, of adjacent property along the route(s) is occupied by residential lands and a minimum of 10 occupied residential units are present on the route.	<i>Not present</i>
		Overall trigger [2/6 required]	No [only 1 out of 6 present]
3.	Application is for Zoning By-Law Amendment or Draft Plan of Subdivision		Yes
4.	At least 75 site-generated auto trips		Yes
5.	Site Trip Infiltration is expected. Site traffic will increase peak hour vehicle volumes along the route by 50% or more.		No
Overall			2 / 5 triggered (5 / 5 required) Therefore, Neighbourhood Traffic Calming is not required to be assessed

²⁶ Revisions to Transportation Impact Assessment Guidelines, Dillon Consulting, effective June 14, 2023

4.7 TRANSIT

The following section discusses projected transit route capacity within the study area and was used to evaluate the need for transit priority measures along the two main corridors serving the development.

4.7.1 Route Capacity

Table 3-4 indicated that the following transit trips are forecast to be generated by the proposed development assuming the various land uses being considered:

- During the morning peak hour, between 8 and 12 transit trips are forecast;
- During the afternoon peak hour, between 7 and 15 transit trips are forecast;

It is noted that the transit mode share was assumed to only be 5%, which was done to conservatively forecast auto-driver trips, and is generally reflective of the somewhat limited availability of transit service within the study area.

Since these additional transit trips are not anticipated to cause capacity constraints for transit routes within the study area.

4.7.2 Transit Priority

Exhibit 2-11 and Table 2-3 presented the existing transit routes and stops within the study area. A review indicated that there is no continuous transit service along the Prince of Wales Drive corridor fronting the development's driveways (service is provided along Hunt Club Road and Deakin Street). Therefore, no transit priority measures were found to warranted along Prince of Wales Drive, and the proposed development's traffic entering and exiting the driveways is unlikely to result in transit delays.

Transit priority measures along Hunt Club Road (Signal Priority and Queue Jump Lanes) are proposed as part of the City of Ottawa's Network Concept (See Sections 2.1.3.1 and 0).

4.7.3 Future Changes to Transit Network

Exhibit 4-2, was referenced from the City of Ottawa's Official Plan, and illustrates future connections to nearest planned LRT stations. With the advent of the new LRT's South and West extensions, significant revision to OC Transpo's bus route network may well occur.

The proposed Prince of Wales Drive site is located approximately 5 km from the future South Keys Station of Lines 2 and 4 and approximately 7 km away from the future Algonquin (presently called Baseline) Station of Line 3. The site could potentially benefit from increased frequencies of existing Route 96 that would connect to South Keys station along Hunt Club Road. There are currently no direct transit Route connection between the future Algonquin Station and the Prince of Wales site.

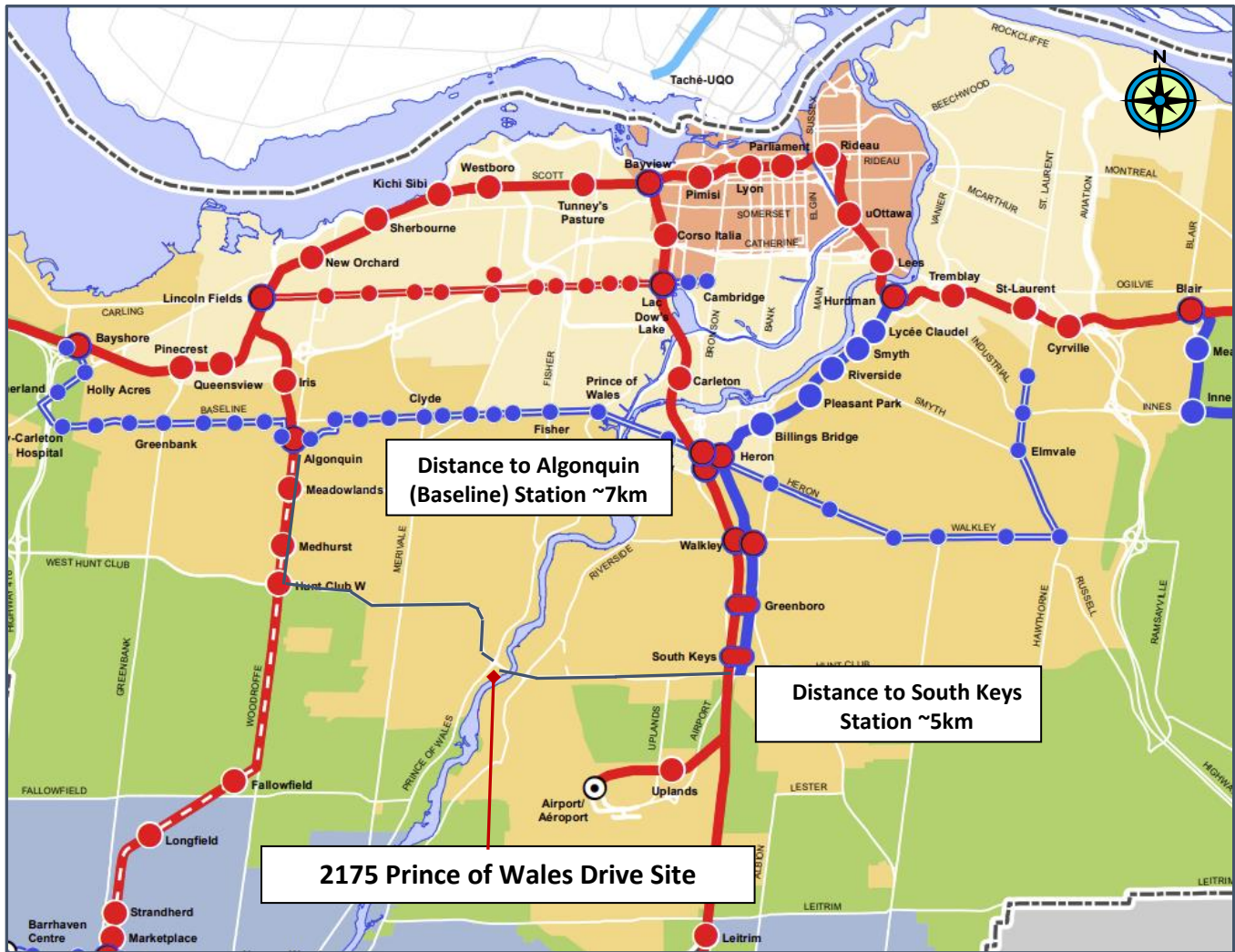

Exhibit 4-2: Distances to Nearest Future LRT Stations (Schedule A OP)

4.8 REVIEW OF NETWORK CONCEPT

The proposed development site is presently zoned “DR-Development Reserve” and is seeking a zoning by-law amendment to permit a wider range of development options. Section 3.1.4 of this report indicates that the site, upon its full build-out and occupancy, will produce between 156 and 465 person-trips per peak hour of travel demand, without considering any pass-by, internal or diverted trips.

The study area can be characterized as having little to no remaining capacity in the existing travel demand conditions (using the pre-pandemic traffic counts as base for forecasting). The existing capacity concerns have already been noted within the City of Ottawa’s Transportation Master Plan (TMP) and addressed by means of developing network concepts, which are addressed below.

This section determines whether any modifications to the future network concepts within the City of Ottawa's Transportation Master Plan are warranted given the advent of the proposed development. It is noted that the City of Ottawa is presently in process of reviewing and approving the New Transportation Master Plan and Capital Infrastructure Plan, which may propose changes to the below network concepts or new network concepts.

4.8.1 Affected Links

The following two major links (arterial roadways) would be most significantly affected by the proposed development's traffic:

- Hunt Club Road and West Hunt Club Road, and
- Prince of Wales Drive.

4.8.2 Adequacy of Network Concepts

The following network concepts were identified within the 2013 Transportation Master Plan

- *Prince of Wales Drive Improvements*: Widening of Prince of Wales Drive corridor between Fisher Avenue and Strandherd Drive from two-to-four lanes. This concept intends to address capacity issues along Prince of Wales Drive. Slight modifications to the original design supported by the Prince of Wales Widening ESR²⁷ would be required to accommodate the proposed site accesses.
- Hunt Club Road Improvements:
 - a. Transit Signal Priority and Queue Jump Lanes along West Hunt Club Road between Woodroffe Avenue and Riverside Drive are listed as part of Transit Priority Projects²⁸;
 - b. Widening of Hunt Club Road east of Riverside Drive (until Bank Street) from four-to-six lanes²⁹;
 - c. Widening of West Hunt Club Road west of Prince of Wales Drive until Highway 416 from four-to-six lanes³⁰;
- The three above concepts intend to address capacity concerns along Hunt Club Road.

Approval of the requested zoning amendment would not result in any required modifications to the above network concepts.

27. "Prince of Wales Drive Widening Fisher Avenue to Woodroffe Avenue Environmental Study Report" Volume I. Morrison Hershfield, October 2011. Page 261, Drawing 23 and 24.

28. City of Ottawa 2013 Transportation Master Plan, Table A2- Transit Priority Projects, page 107

29. City of Ottawa 2013 Transportation Master Plan, Table A3- Road Projects, page 111

30. City of Ottawa 2013 Transportation Master Plan, Table A3- Road Projects, page 114

4.8.3 Screenlines

Exhibit 4-3 provides a review of TRANS Transportation Planning Committee's screenlines in the vicinity of the study area.

Traffic generated by the development of the Prince of Wales site will result in traffic volumes increasing slightly across the following screenlines:

- **SL9** at Prince of Wales (location id 50030),
- **SL12** at Prince of Wales (location id 50031),
- **SL20** at Hunt Club (location id 03205), and
- **SL25** at Hunt Club (location id 03202).

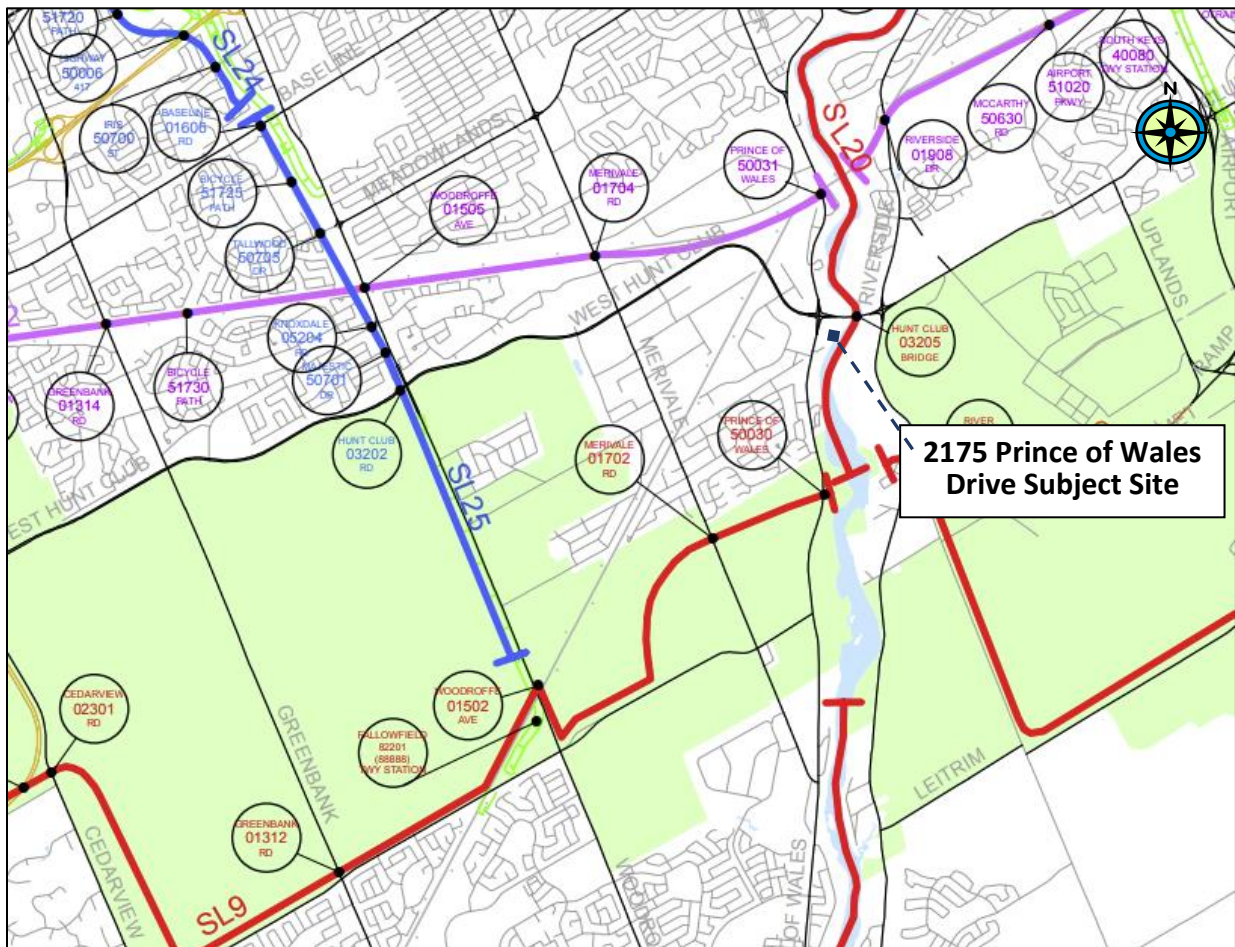

Exhibit 4-3: Adjacent Screenlines

4.9 NETWORK INTERSECTIONS

The following sub-sections provide total traffic analysis (including a combination of background traffic and development-generated traffic), including the multi-modal level of service analysis and vehicle level of service analysis for each of the four development options considered within this TIA.

Appendix “J” provides Synchro™ analysis output sheets for each of the four proposed land use options in 2025 and 2030 total traffic conditions.

4.9.1 Intersection Control

The two study area intersections of Hunt Club Road / Prince of Wales Drive and Prince of Wales Drive / Deakin Street are to continue to operate as signalized intersections. Given the heavy traffic volumes along both intersections during the peak hours of travel demand, roundabouts are not being considered for these intersections.

As previously discussed in Section 4.4.2, both site access intersections are to operate as a minor-leg STOP controlled intersections. Traffic signals or roundabouts for access intersections are not being considered.

4.9.2 Intersection Design

The following sub-sections provide the total traffic network analysis, which includes background traffic discussed within Section 3.2.4, along with the development-generated traffic discussed in section 3.1.4.

4.9.2.1 MMLOS Analysis

Table 4-5 provides Multi-Modal Level of Service analysis for the two signalized study area intersections. The results of MMLOS analysis are not forecast to vary between the development scenarios.

As per the City of Ottawa’s Multi-Modal Level of Service Guidelines³¹, only the two signalized study area intersections are included in this analysis. Appendix “I” provides the calculation spreadsheet.

Table 4-5: Intersection MMLOS Analysis

Intersection	Intersection Leg	PLOS		BLOS		TLOS		IkLOS	
		Forecast	Target	Forecast	Target	Forecast	Target	Forecast	Target
Hunt Club Road / Prince of Wales Drive	East Leg	F	C	C	C	F	D	A	C
	West Leg	F	C	C	C	F	D	A	C
	North Leg	F	C	C	B	F	D	A	C
	South Leg	F	C	C	B	F	D	A	C
	Overall	F	C	C	B	F	D	A	C
	West Leg	F	C	C	B	F	D	N/A	N/A
	North Leg	F	C	A	B	B	D	A	C

Prince of Wales Drive / Deakin Street	South Leg	F	C	C	B	B	D	A	C
	Overall	F	C	C	B	F	D	C	C

Note – Levels of Service highlighted in bold font fail to meet the respective target LOS

Pedestrian Level of Service (PLOS): Pedestrian level of service at both intersections is “F”, which is attributed primarily to long crossing distances, lack of protected right turns and lack of leading pedestrian intervals. It is noted that there is no pedestrian crossing along the north leg of Prince of Wales Drive / Deakin Street intersection.

Bicycle Level of Service (BLOS): Two-stage left turn bike boxes are provided at each intersection, which would typically yield a BLOS “A” along low speed roadways. However, the operating speed of over 60 km/hr yields a BLOS “C” for both study area intersections. This level of service is just under the desired BLOS “B” for cross-town bikeway (Prince of Wales Drive).

Transit Level of Service (TLOS): Intersection of Hunt Club Road and Prince of Wales Drive is experiencing significant delays caused by long signal cycle during the peak hours of travel demand, yielding a TLOS “F”. The west leg (Deakin Street) of Prince of Wales Drive / Deakin Street intersection is similarly forecast to exhibit TLOS “F”.

Truck Level of Service (TkLOS): Both intersections were found to meet their target for TkLOS, as they provide for large effective corner radii and two receiving lanes.

4.9.2.2 Operations Analysis - Option 1: Auto Dealership (80,000 sqft) Traffic

The total study area network traffic generated by an 80,000 sqft auto dealership is illustrated within the following exhibits:

- Exhibit 4-4 illustrates the total study area traffic in the horizon year 2025 (build-out);
- Exhibit 4-5 illustrates the total study area traffic in the horizon year 2030 (5 years after build-out).
- Table 4-6 provides the total traffic analysis associated with an advent of the 80,000 sqft auto dealership, combined with the background traffic in both 2025 and 2030 horizon years.

4.9.2.3 Operations Analysis - Option 2: Hotel (400 Rooms) Traffic

The total study area network traffic generated by a 400-room hotel is illustrated within the following exhibits:

- Exhibit 4-6 illustrates the total study area traffic in the horizon year 2025 (build-out);
- Exhibit 4-7 illustrates the total study area traffic in the horizon year 2030 (5 years after build-out).
- Table 4-7 provides the total traffic analysis associated with an advent of the 400-room hotel, combined with the background traffic in both 2025 and 2030 horizon years.

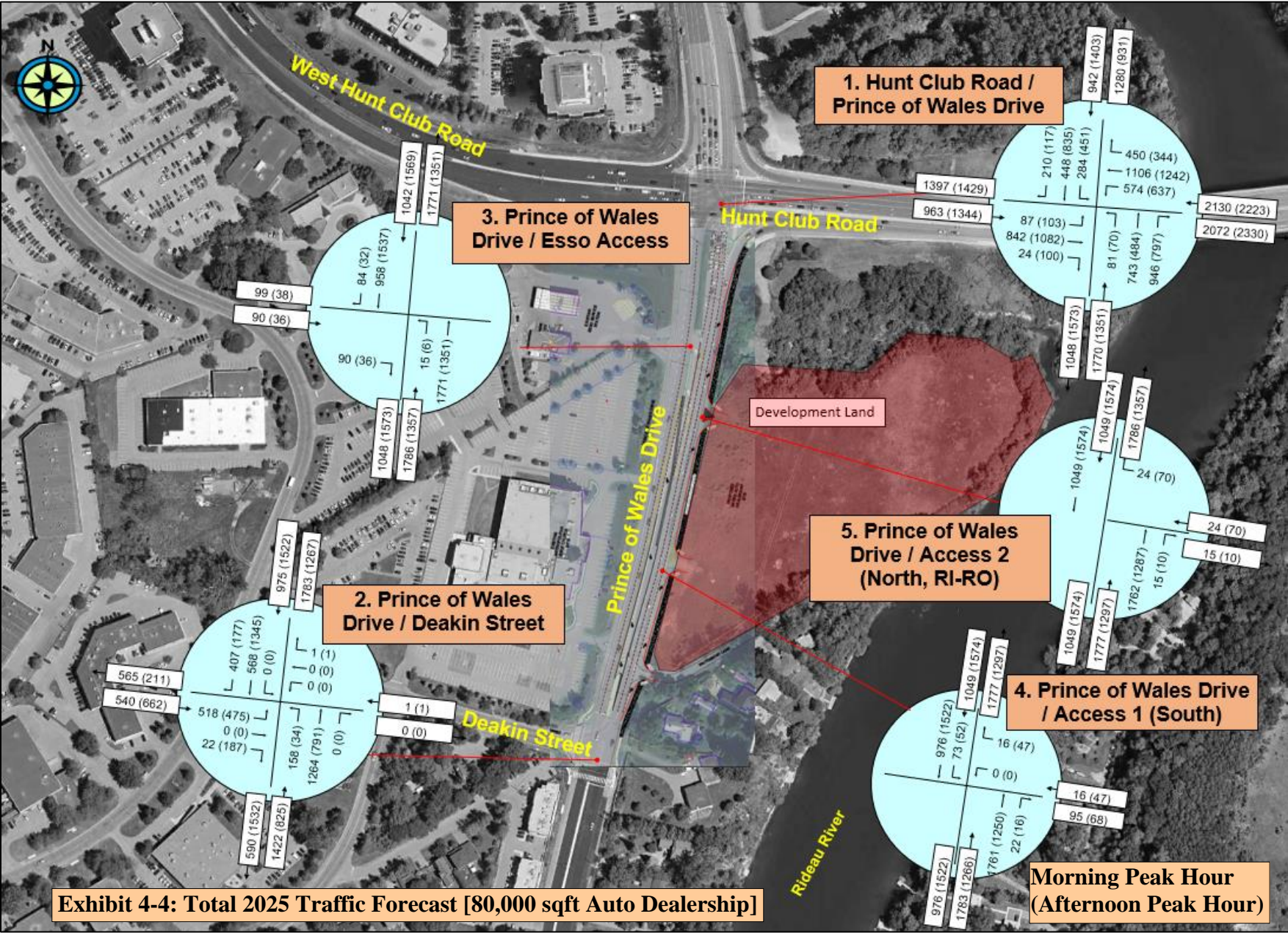

Exhibit 4-4: Total 2025 Traffic Forecast [80,000 sqft Auto Dealership]

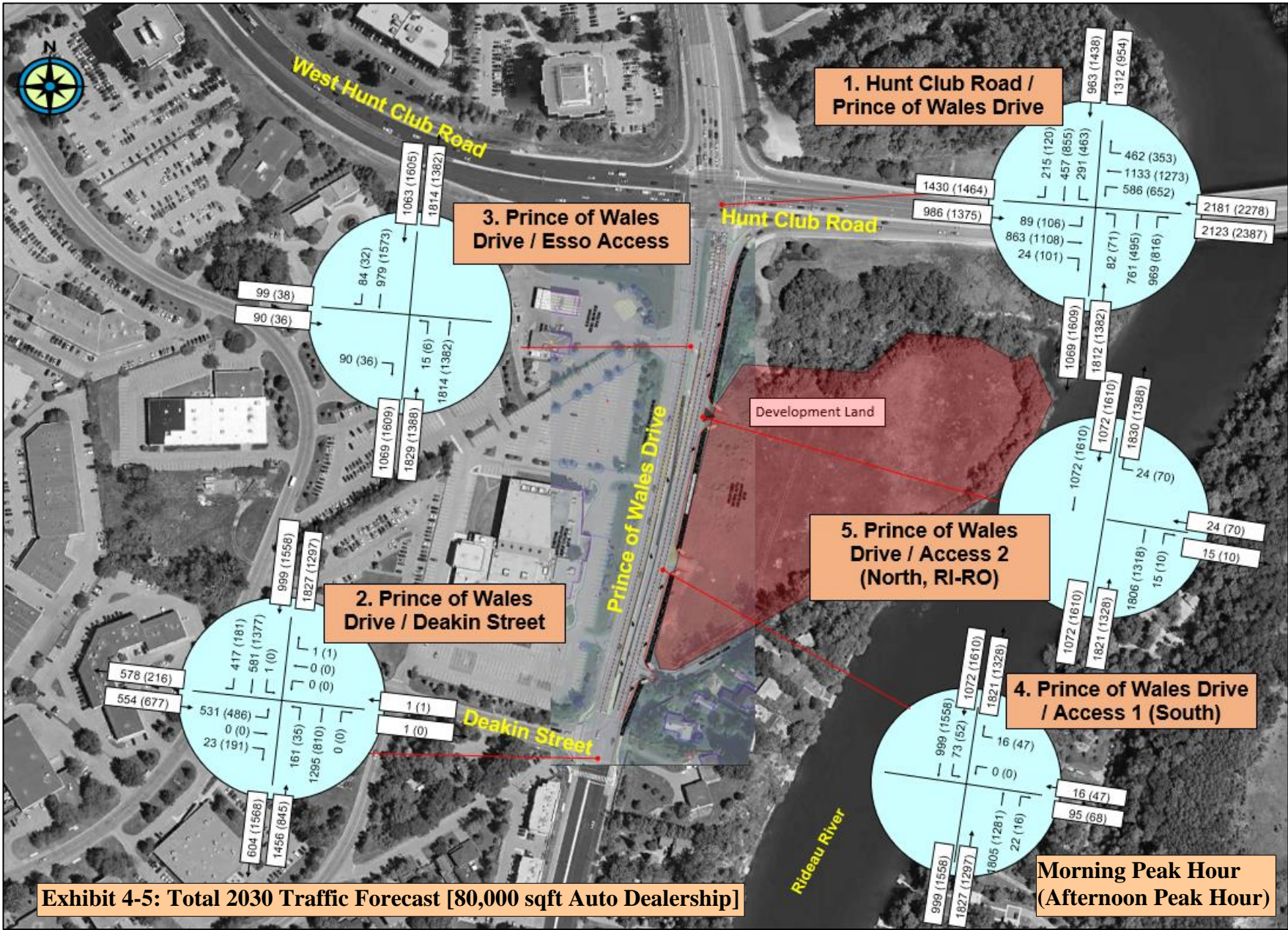

Exhibit 4-5: Total 2030 Traffic Forecast [80,000 sqft Auto Dealership]

Table 4-6: Total (2025 and 2030) Traffic Analysis [Assuming 80,000 SF Auto Dealership]

Intersection	Control Type	Weekday Morning Peak Hour (Afternoon Peak Hour)				
		Critical Movement	95 th Percentile Queue (m)	Delay (seconds)	v/c Ratio	LOS
Total 2025						
1. Hunt Club Road and Prince of Wales Drive	Traffic Signal	NB-LT	36 (49)	80.7 (163.5)	0.60 (0.96)	B (E)
		NB-TH	117 (97)	57.6 (81.8)	0.83 (0.90)	D (E)
		NB-RT	362 (317)	267.3 (325)	1.52 (1.64)	F (F)
		EB-RT	0 (0)	0.1 (0.2)	0.02 (0.08)	A (A)
		SB-TH	67 (156)	44.6 (74.5)	0.49 (0.95)	A (E)
		WB-LT	123 (152)	145.9 (216.5)	1.17 (1.35)	F (F)
2. Prince of Wales Drive and Deakin Street	Traffic Signal	SB-TH	43 (115)	6.4 (13.4)	0.45 (0.68)	A (B)
		NB-TH	89 (44)	11.4 (8.8)	0.57 (0.35)	A (A)
		EB-LT	59 (99)	44.0 (63.9)	0.76 (0.92)	C (E)
3. Prince of Wales Drive and Esso Service Station Access	Assumed Minor Leg-STOP	EB-RT	7 (4)	17.2 (21.1)	0.23 (0.14)	A (A)
		NB-LT	1 (1)	15.6 (23.9)	0.04 (0.03)	A (A)
4. Prince of Wales Drive and Access 1 (South Access)	Minor Leg-STOP	SB-LT [into the access]	16 (5)	44.7 (20.0)	0.45 (0.18)	A (A)
		WB-RT [out of the access]	2 (3)	20.7 (16.4)	0.07 (0.13)	A (A)
5. Prince of Wales Drive and Access 2 (North Access)	Minor Leg-STOP	WB-RT [out of the access]	2 (5)	21.2 (17.7)	0.10 (0.20)	A (A)
Total 2030						
1. Hunt Club Road and Prince of Wales Drive	Traffic Signal	NB-LT	36 (50)	81.1 (167.0)	0.61 (0.97)	B (E)
		NB-TH	120 (101)	59.0 (84.6)	0.85 (0.92)	D (E)
		NB-RT	375 (355)	284.4 (387)	1.56 (1.79)	F (F)
		EB-RT	0 (0)	0.1 (0.2)	0.02 (0.08)	A (A)
		SB-TH	69 (162)	44.8 (78.8)	0.50 (0.97)	A (E)
		WB-LT	126 (157)	154.4 (229.0)	1.19 (1.38)	F (F)
2. Prince of Wales Drive and Deakin Street	Traffic Signal	SB-TH	44 (121)	6.6 (13.9)	0.46 (0.69)	A (B)
		NB-TH	92 (46)	11.8 (8.9)	0.59 (0.35)	A (A)
		EB-LT	61 (103)	44.1 (66.4)	0.77 (0.95)	C (E)
3. Prince of Wales Drive and Esso Service Station Access	Assumed Minor Leg-STOP	EB-RT	7 (4)	17.4 (21.7)	0.24 (0.14)	A (A)
		NB-LT	1 (1)	15.8 (24.8)	0.04 (0.03)	A (A)
4. Prince of Wales Drive and Access 1 (South Access)	Minor Leg-STOP	SB-LT [into the access]	17 (5)	48.3 (20.7)	0.48 (0.19)	A (A)
		WB-RT [out of the access]	2 (4)	21.3 (16.7)	0.07 (0.13)	A (A)
5. Prince of Wales Drive and Access 2 (North Access)	Minor Leg-STOP	WB-RT [out of the access]	2 (5)	21.8 (18.0)	0.10 (0.20)	A (A)

Analysis was undertaken using Synchro™ V11 traffic analysis software. See Appendix "J" for Synchro analysis output sheets.

Assumed 2025 and 2030 Forecast traffic volumes. See Exhibit 4-4 and Exhibit 4-5.

Analysis was carried using the traffic-signal timings phasing that were provided by the City of Ottawa. See Appendix "B".

Analysis assumes a peak hour factor (PHF) of 1.00.

Values outside of Brackets represent Morning Peak Hour Values.

Values inside of Brackets represent Afternoon Peak Hour Values.

Values that are in Bold indicate unsatisfactory results / parameters.

Movements that are forecast to be affected by the proposed development's traffic are shown

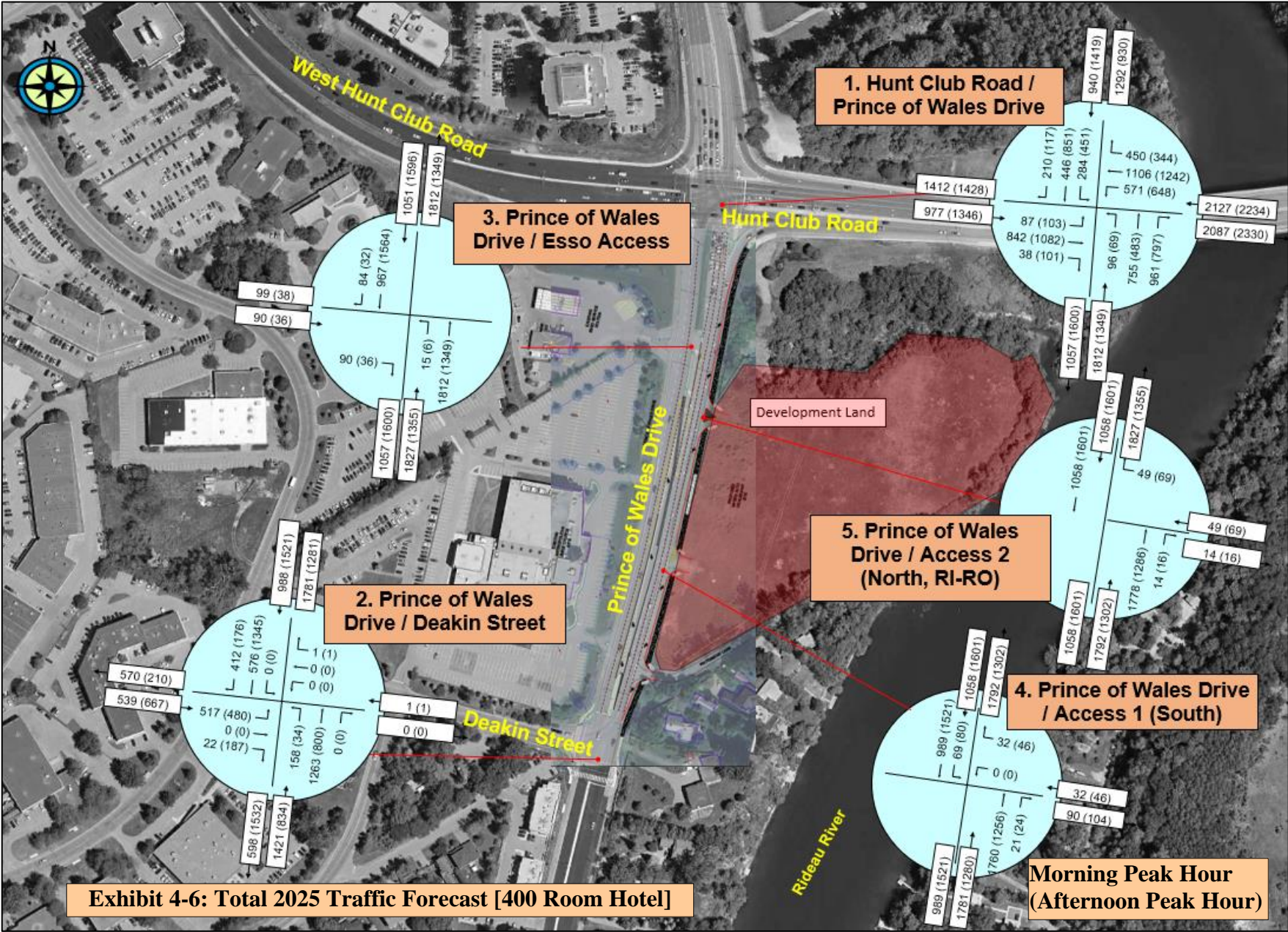

Exhibit 4-6: Total 2025 Traffic Forecast [400 Room Hotel]

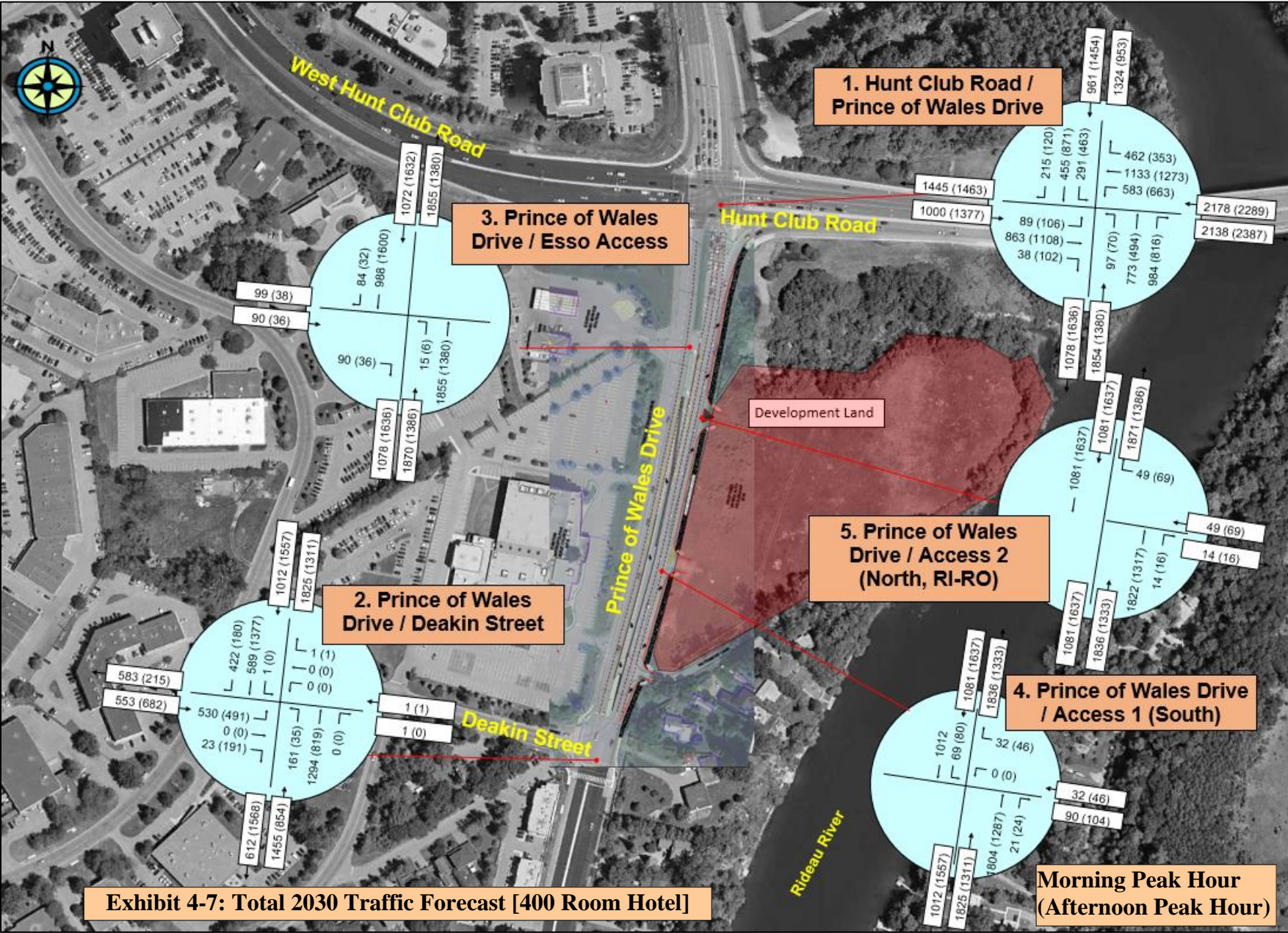

Exhibit 4-7: Total 2030 Traffic Forecast [400 Room Hotel]

Table 4-7: Total (2025 and 2030) Traffic Analysis [Assuming 400-Room Hotel]

Intersection	Control Type	Weekday Morning Peak Hour (Afternoon Peak Hour)				
		Critical Movement	95 th Percentile Queue (m)	Delay (seconds)	v/c Ratio	LOS
Total 2025						
1. Hunt Club Road and Prince of Wales Drive	Traffic Signal	NB-LT	42 (48)	85.6 (160.1)	0.68 (0.95)	B (E)
		NB-TH	119 (97)	58.5 (81.5)	0.84 (0.90)	D (E)
		NB-RT	370 (345)	277.7 (369)	1.54 (1.74)	F (F)
		EB-RT	0 (0)	0.1 (0.2)	0.02 (0.08)	A (A)
		SB-TH	67 (161)	45.1 (77.8)	0.50 (0.97)	A (E)
		WB-LT	122 (156)	143.8 (225.6)	1.16 (1.37)	F (F)
2. Prince of Wales Drive and Deakin Street	Traffic Signal	SB-TH	44 (115)	6.5 (13.4)	0.45 (0.68)	A (B)
		NB-TH	88 (45)	11.3 (8.8)	0.57 (0.35)	A (A)
		EB-LT	59 (100)	44.0 (64.8)	0.76 (0.92)	C (E)
3. Prince of Wales Drive and Esso Service Station Access	Assumed Minor Leg-STOP	EB-RT	7 (4)	17.3 (21.5)	0.24 (0.14)	A (A)
		NB-LT	1 (1)	15.7 (24.6)	0.04 (0.03)	A (A)
4. Prince of Wales Drive and Access 1 (South Access)	Minor Leg-STOP	SB-LT [into the access]	14 (8)	43.2 (22.4)	0.43 (0.28)	A (A)
		WB-RT [out of the access]	3 (3)	21.9 (16.5)	0.13 (0.13)	A (A)
5. Prince of Wales Drive and Access 2 (North Access)	Minor Leg-STOP	WB-RT [out of the access]	5 (5)	23.5 (17.7)	0.20 (0.20)	A (A)
Total 2030						
1. Hunt Club Road and Prince of Wales Drive	Traffic Signal	NB-LT	42 (49)	85.8 (163.5)	0.68 (0.96)	B (E)
		NB-TH	125 (101)	60.1 (84.3)	0.86 (0.92)	D (E)
		NB-RT	383 (355)	294.8 (387)	1.56 (1.79)	F (F)
		EB-RT	0 (0)	0.1 (0.2)	0.02 (0.08)	A (A)
		SB-TH	68 (167)	45.3 (82.8)	0.51 (0.99)	A (E)
		WB-LT	125 (160)	152.2 (238.2)	1.18 (1.40)	F (F)
2. Prince of Wales Drive and Deakin Street	Traffic Signal	SB-TH	45 (120)	6.7 (13.9)	0.47 (0.69)	A (B)
		NB-TH	92 (46)	11.7 (9.2)	0.58 (0.36)	A (A)
		EB-LT	61 (104)	44.2 (66.9)	0.77 (0.95)	C (E)
3. Prince of Wales Drive and Esso Service Station Access	Assumed Minor Leg-STOP	EB-RT	7 (4)	17.6 (22.0)	0.24 (0.14)	A (A)
		NB-LT	1 (1)	16.0 (25.5)	0.04 (0.03)	A (A)
4. Prince of Wales Drive and Access 1 (South Access)	Minor Leg-STOP	SB-LT [into the access]	16 (9)	46.5 (23.3)	0.45 (0.29)	A (A)
		WB-RT [out of the access]	4 (3)	22.5 (16.8)	0.14 (0.13)	A (A)
5. Prince of Wales Drive and Access 2 (North Access)	Minor Leg-STOP	WB-RT [out of the access]	6 (5)	24.3 (18.1)	0.21 (0.20)	A (A)

Analysis was undertaken using Synchro™ V11 traffic analysis software. See Appendix "J" for Synchro analysis output sheets.

Assumed 2025 and 2030 Forecast traffic volumes. See Exhibit 4-6 and Exhibit 4-7 Exhibit 4-4: Total 2025 Traffic Forecast [80,000 sqft Auto Dealership].

Analysis was carried using the traffic-signal timings phasing that were provided by the City of Ottawa. See Appendix "B".

Analysis assumes a peak hour factor (PHF) of 1.00.

Values outside of Brackets represent Morning Peak Hour Values.

Values inside of Brackets represent Afternoon Peak Hour Values.

Values that are in Bold indicate unsatisfactory results / parameters.

Movements that are forecast to be affected by the proposed development's traffic are shown

4.9.2.4 Operations Analysis - Option 3: Office (80,000 sqft) Traffic

The total study area network traffic generated by an 80,000 sqft office is illustrated within the following exhibits:

- Exhibit 4-8 illustrates the total study area traffic in the horizon year 2025 (build-out);
- Exhibit 4-9 illustrates the total study area traffic in the horizon year 2030 (5 years after build-out).
- Table 4-8 provides the total traffic analysis associated with an advent of the 80,000 sqft office, combined with the background traffic in both 2025 and 2030 horizon years.

4.9.2.5 Operations Analysis - Option 4: Retail Plaza (70,000 sqft) Traffic

The total study area network traffic generated by a 70,000 sqft retail plaza is illustrated within the following exhibits:

- Exhibit 4-10 illustrates the total study area traffic in the horizon year 2025 (build-out);
- Exhibit 4-11 illustrates the total study area traffic in the horizon year 2030 (5 years after build-out).
- Table 4-9 provides the total traffic analysis associated with an advent of the 70,000 sqft retail plaza, combined with the background traffic in both 2025 and 2030 horizon years

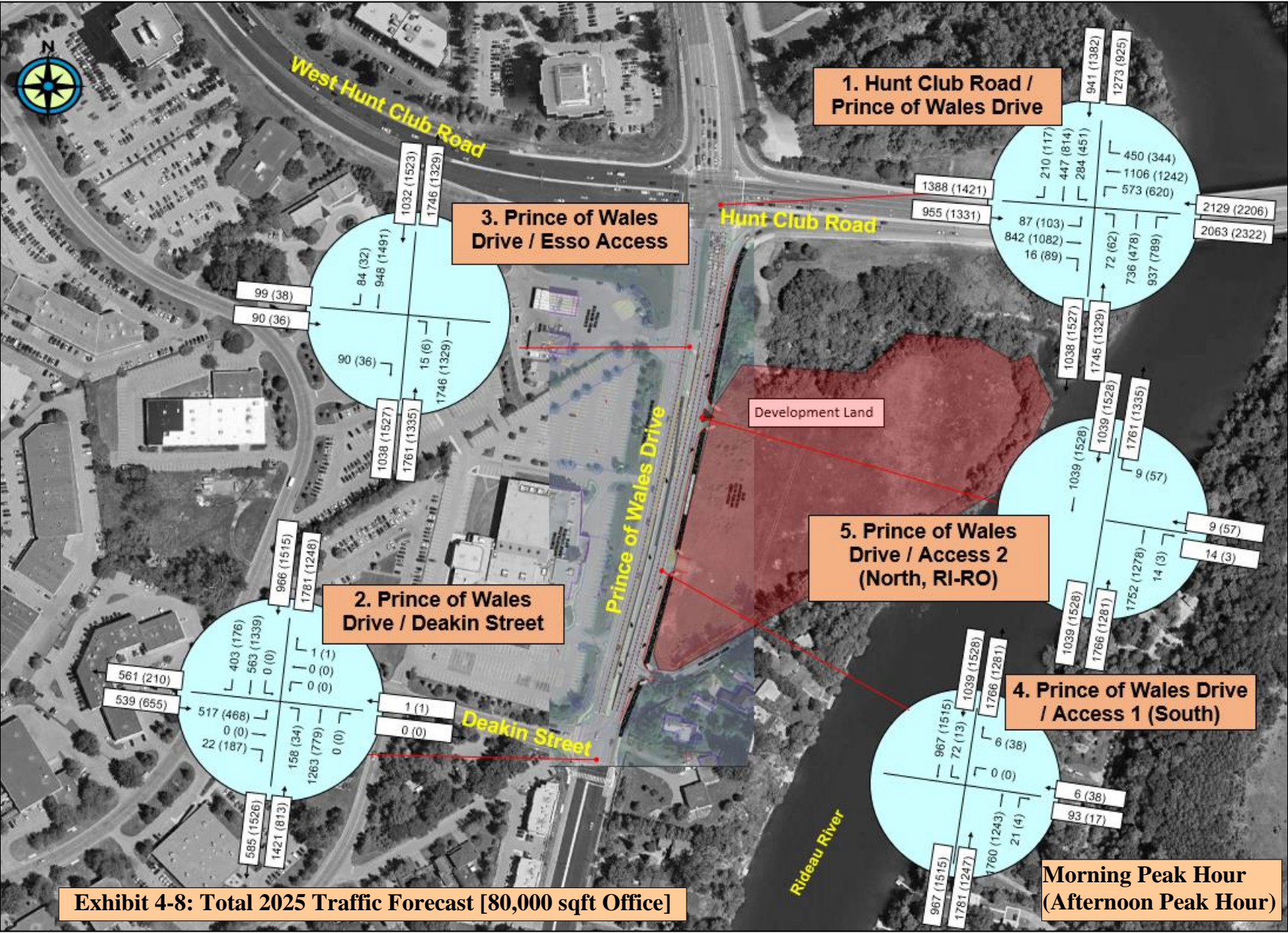

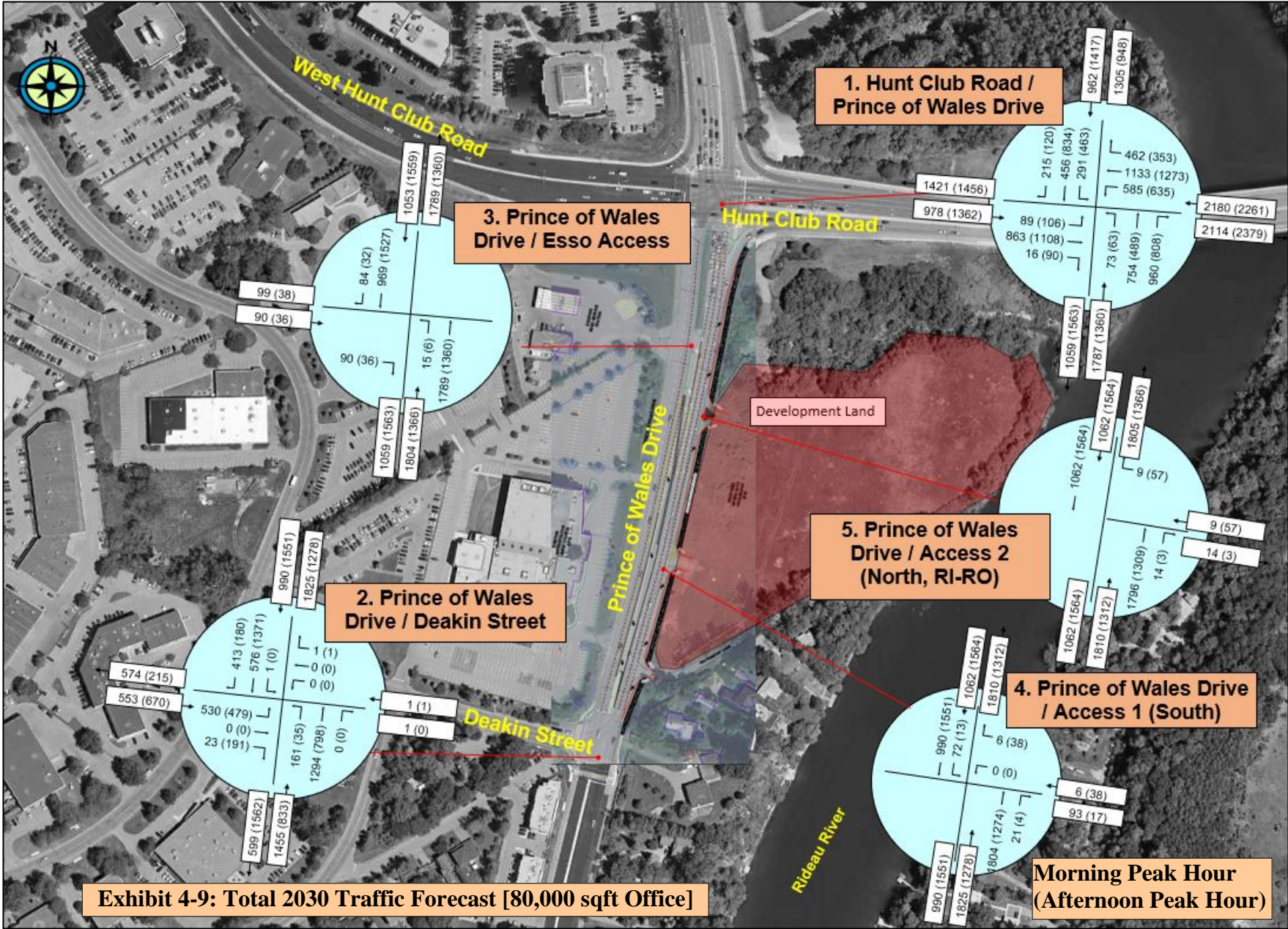

Exhibit 4-9: Total 2030 Traffic Forecast [80,000 sqft Office]

Table 4-8: Total (2025 and 2030) Traffic Analysis [Assuming 80,000 SF Office]

Intersection	Control Type	Weekday Morning Peak Hour (Afternoon Peak Hour)				
		Critical Movement	95 th Percentile Queue (m)	Delay (seconds)	v/c Ratio	LOS
Total 2025						
1. Hunt Club Road and Prince of Wales Drive	Traffic Signal	NB-LT	33 (43)	78.1 (138.5)	0.56 (0.85)	A (E)
		NB-TH	115 (95)	57.1 (80.4)	0.82 (0.89)	D (D)
		NB-RT	356 (340)	261.1 (361.7)	1.50 (1.73)	F (F)
		EB-RT	0 (0)	0.1 (0.2)	0.02 (0.08)	A (A)
		SB-TH	67 (150)	42.6 (70.8)	0.46 (0.93)	A (E)
		WB-LT	123 (147)	145.2 (202.6)	1.16 (1.31)	F (F)
2. Prince of Wales Drive and Deakin Street	Traffic Signal	SB-TH	42 (114)	6.3 (13.3)	0.44 (0.67)	A (B)
		NB-TH	88 (44)	11.3 (8.7)	0.57 (0.34)	A (A)
		EB-LT	59 (97)	44.0 (62.7)	0.76 (0.90)	C (E)
3. Prince of Wales Drive and Esso Service Station Access	Assumed Minor Leg-STOP	EB-RT	7 (4)	17.1 (20.5)	0.23 (0.13)	A (A)
		NB-LT	1 (1)	15.5 (23.0)	0.04 (0.03)	A (A)
4. Prince of Wales Drive and Access 1 (South Access)	Minor Leg-STOP	SB-LT [into the access]	15 (1)	44.3 (17.7)	0.45 (0.04)	A (A)
		WB-RT [out of the access]	2 (2)	20.1 (15.9)	0.02 (0.10)	A (A)
5. Prince of Wales Drive and Access 2 (North Access)	Minor Leg-STOP	WB-RT [out of the access]	1 (5)	20.1 (17.0)	0.04 (0.16)	A (A)
Total 2030						
1. Hunt Club Road and Prince of Wales Drive	Traffic Signal	NB-LT	33 (44)	78.3 (141.3)	0.56 (0.86)	A (E)
		NB-TH	119 (99)	58.4 (83.0)	0.84 (0.91)	D (E)
		NB-RT	370 (350)	278.1 (379.7)	1.54 (1.77)	F (F)
		EB-RT	0 (0)	0.1 (0.2)	0.02 (0.08)	A (A)
		SB-TH	69 (156)	42.8 (74.3)	0.47 (0.95)	A (E)
		WB-LT	126 (151)	153.7 (214.9)	1.19 (1.34)	F (F)
2. Prince of Wales Drive and Deakin Street	Traffic Signal	SB-TH	44 (119)	6.6 (13.7)	0.46 (0.69)	A (B)
		NB-TH	92 (45)	11.7 (8.8)	0.58 (0.35)	A (A)
		EB-LT	61 (101)	44.2 (65.2)	0.77 (0.94)	C (E)
3. Prince of Wales Drive and Esso Service Station Access	Assumed Minor Leg-STOP	EB-RT	7 (4)	17.3 (21.0)	0.24 (0.14)	A (A)
		NB-LT	1 (1)	15.7 (23.7)	0.04 (0.03)	A (A)
4. Prince of Wales Drive and Access 1 (South Access)	Minor Leg-STOP	SB-LT [into the access]	17 (1)	47.9 (18.1)	0.48 (0.05)	A (A)
		WB-RT [out of the access]	1 (3)	20.6 (16.2)	0.07 (0.11)	A (A)
5. Prince of Wales Drive and Access 2 (North Access)	Minor Leg-STOP	WB-RT [out of the access]	1 (5)	20.6 (17.3)	0.04 (0.16)	A (A)

Analysis was undertaken using Synchro™ V11 traffic analysis software. See Appendix "J" for Synchro analysis output sheets.

Assumed 2025 and 2030 Forecast traffic volumes. See Exhibit 4-8 and Exhibit 4-9
Exhibit 4-4: Total 2025 Traffic Forecast [80,000 sqft Auto Dealership].

Analysis was carried using the traffic-signal timings phasing that were provided by the City of Ottawa. See Appendix "B".

Analysis assumes a peak hour factor (PHF) of 1.00.

Values outside of Brackets represent Morning Peak Hour Values.

Values inside of Brackets represent Afternoon Peak Hour Values.

Values that are in Bold indicate unsatisfactory results / parameters.

Movements that are forecast to be affected by the proposed development's traffic are shown

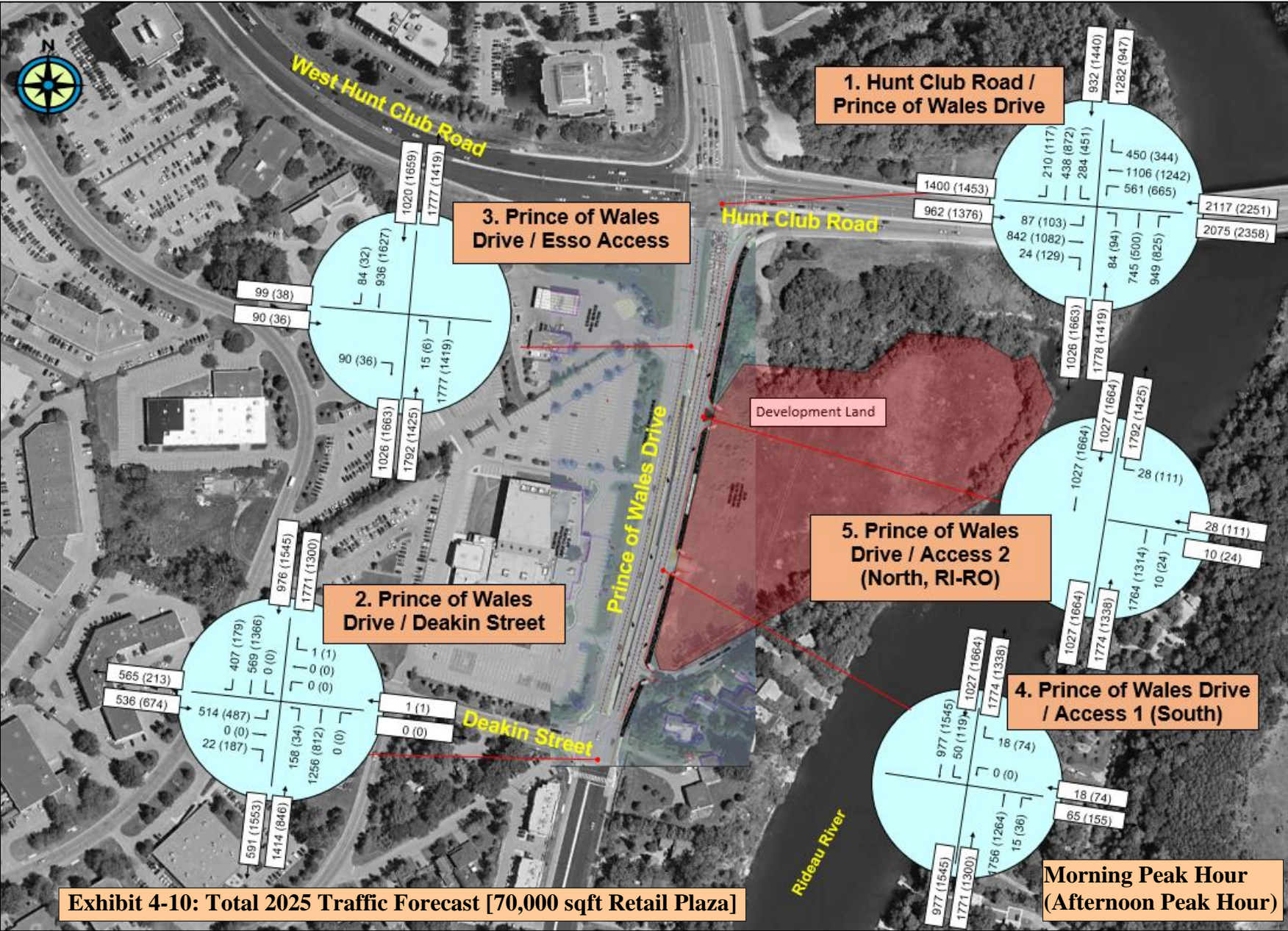

Exhibit 4-10: Total 2025 Traffic Forecast [70,000 sqft Retail Plaza]

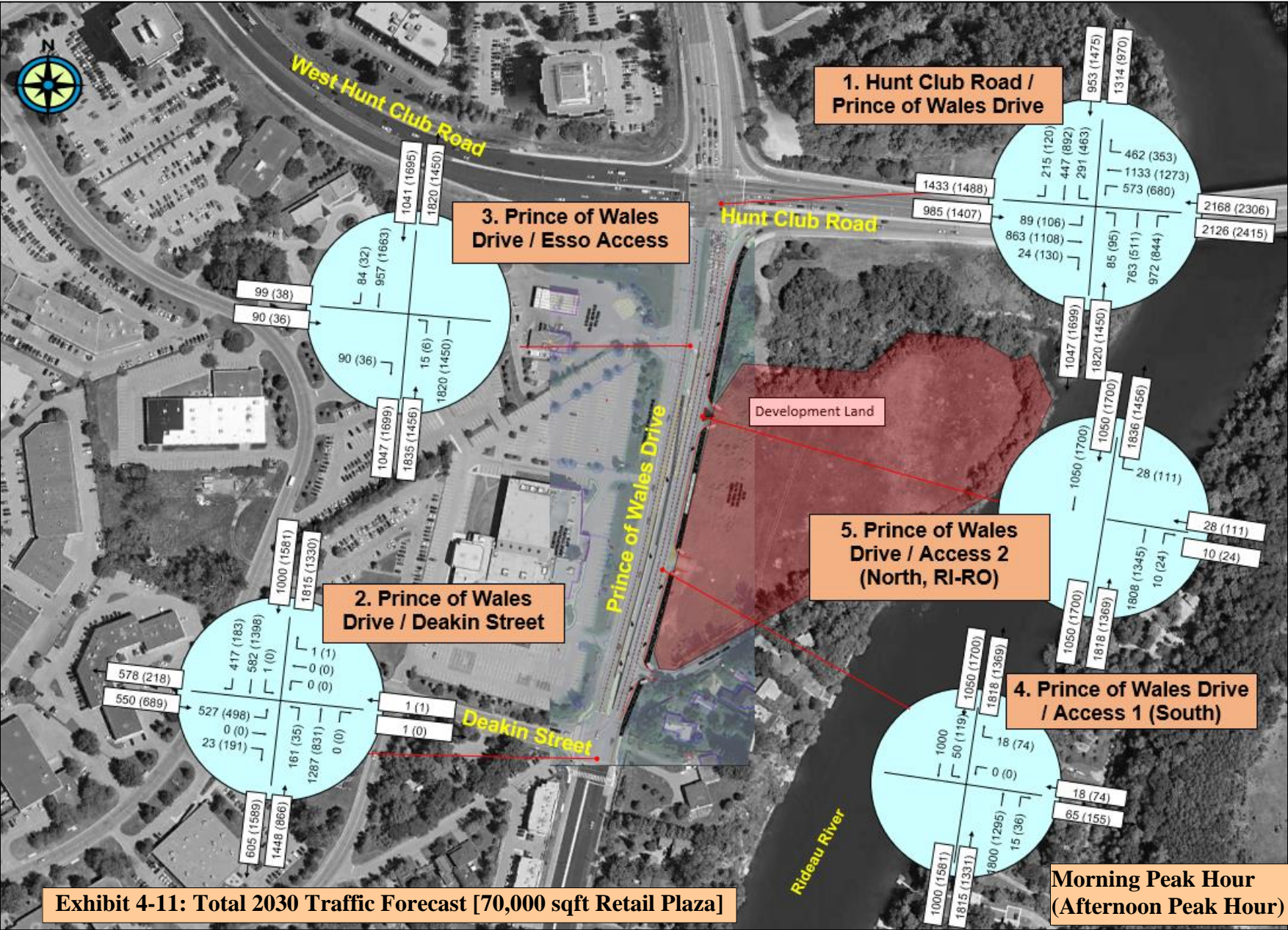

Exhibit 4-11: Total 2030 Traffic Forecast [70,000 sqft Retail Plaza]

Table 4-9: Total (2025 and 2030) Traffic Analysis [Assuming 70,000 SF Retail Plaza]

Intersection	Control Type	Weekday Morning Peak Hour (Afternoon Peak Hour)				
		Critical Movement	95 th Percentile Queue (m)	Delay (seconds)	v/c Ratio	LOS
Total 2025						
1. Hunt Club Road and Prince of Wales Drive	Traffic Signal	NB-LT	37 (67)	81.7 (253.4)	0.62 (1.29)	B (F)
		NB-TH	117 (102)	57.7 (86.0)	0.83 (0.93)	D (E)
		NB-RT	363 (360)	269.4 (396)	1.52 (1.81)	F (F)
		EB-RT	0 (0)	0.0 (0.2)	0.02 (0.08)	A (A)
		SB-TH	66 (167)	44.4 (83.0)	0.48 (0.99)	A (E)
		WB-LT	119 (161)	137.0 (239.8)	1.14 (1.41)	F (F)
2. Prince of Wales Drive and Deakin Street	Traffic Signal	SB-TH	43 (122)	6.4 (13.9)	0.45 (0.70)	A (C)
		NB-TH	88 (46)	11.2 (8.9)	0.56 (0.36)	A (A)
		EB-LT	59 (102)	44.0 (66.0)	0.76 (0.95)	C (E)
3. Prince of Wales Drive and Esso Service Station Access	Assumed Minor Leg-STOP	EB-RT	7 (4)	16.9 (22.5)	0.23 (0.15)	A (A)
		NB-LT	1 (1)	15.3 (26.2)	0.04 (0.03)	A (A)
4. Prince of Wales Drive and Access 1 (South Access)	Minor Leg-STOP	SB-LT [into the access]	9 (15)	36.6 (27.0)	0.31 (0.43)	A (A)
		WB-RT [out of the access]	2 (6)	20.7 (17.9)	0.07 (0.21)	A (A)
5. Prince of Wales Drive and Access 2 (North Access)	Minor Leg-STOP	WB-RT [out of the access]	3 (10)	21.4 (20.4)	0.11 (0.32)	A (A)
Total 2030						
1. Hunt Club Road and Prince of Wales Drive	Traffic Signal	NB-LT	38 (68)	81.9 (257.9)	0.62 (1.30)	B (F)
		NB-TH	121 (106)	59.2 (89.4)	0.85 (0.95)	D (E)
		NB-RT	377 (372)	286.4 (414.0)	1.56 (1.85)	F (F)
		EB-RT	0 (0)	0.1 (0.2)	0.02 (0.08)	A (A)
		SB-TH	67 (173)	44.7 (88.0)	0.49 (1.01)	A (F)
		WB-LT	123 (165)	145.2 (252.5)	1.16 (1.44)	F (F)
2. Prince of Wales Drive and Deakin Street	Traffic Signal	SB-TH	44 (124)	6.6 (14.2)	0.46 (0.71)	A (C)
		NB-TH	91 (47)	11.6 (9.1)	0.58 (0.36)	A (A)
		EB-LT	60 (106)	44.2 (67.9)	0.77 (0.95)	C (E)
3. Prince of Wales Drive and Esso Service Station Access	Assumed Minor Leg-STOP	EB-RT	7 (4)	17.2 (23.1)	0.23 (0.15)	A (A)
		NB-LT	1 (1)	15.6 (27.1)	0.04 (0.04)	A (A)
4. Prince of Wales Drive and Access 1 (South Access)	Minor Leg-STOP	SB-LT [into the access]	10 (16)	38.9 (28.4)	0.32 (0.44)	A (A)
		WB-RT [out of the access]	2 (6)	21.3 (18.3)	0.08 (0.21)	A (A)
5. Prince of Wales Drive and Access 2 (North Access)	Minor Leg-STOP	WB-RT [out of the access]	3 (11)	22.1 (21.0)	0.12 (0.33)	A (A)

Analysis was undertaken using Synchro™ V11 traffic analysis software. See Appendix "J" for Synchro analysis output sheets.

Assumed 2025 and 2030 Forecast traffic volumes. See Exhibit 4-10 and Exhibit 4-11

Analysis was carried using the traffic-signal timings phasing that were provided by the City of Ottawa. See Appendix "B".

Analysis assumes a peak hour factor (PHF) of 1.00.

Values outside of Brackets represent Morning Peak Hour Values.

Values inside of Brackets represent Afternoon Peak Hour Values.

Values that are in Bold indicate unsatisfactory results / parameters.

Movements that are forecast to be affected by the proposed development's traffic are shown

4.9.3 Access Operations

4.9.3.1 Location and Design of Access

Exhibit 4-12 illustrates the design and characteristics of the two proposed site accesses. Concept plan is also provided within Appendix “D”. The proposed accesses:

- Are spaced approximately 100 metres apart (centreline-to-centreline);
- The centreline of Access 2 (north access) is located approximately:
 - 120 metres south of the stop bar at the Hunt Club Road / Prince of Wales intersection,
 - 45 metres south of the Esso Service station access,
 - 50 metres north of MET’s (Metropolitan Bible Church) north access,
- The centreline of Access 1 (south access) is located approximately:
 - 75 metres north of the departure end of curve of Waterbend Lane,
 - 110 metres north of the stop bar at the Prince of Wales Drive / Deakin Street intersection,
 - 50 metres south of MET’s north access, and
 - 65 metres north of MET’s south access.

Access Spacing and the Private Approach By-Law

The frontage of the site along prince of Wales Drive is approximately 185m long, the proposed two accesses are separated by 100m and the distance between the south access and Waterbend Lane is 75m. The proposed two accesses fully comply with the Private Approach By-Law (Section 25 (1) (a)) as concerns the number of permitted accesses and also complies with Section 25 (1) (m) regarding the spacing of the accesses and separation from Waterbend Lane.

4.9.3.2 Access Design

Proposed Median

A concrete median is proposed to be instated along Prince of Wales Drive in the vicinity of Access 2. The median is proposed to extend just north of Access 1 and terminate right before the access to allow left turns into the site.

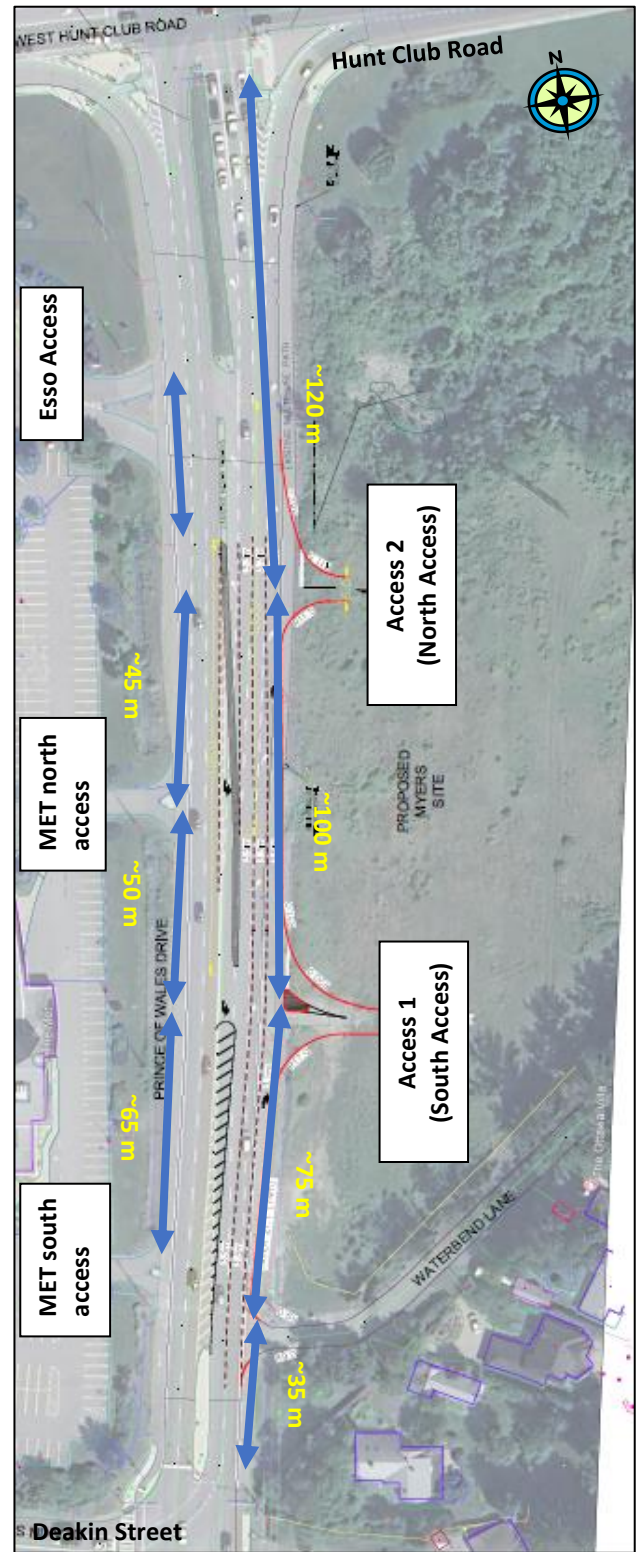

Exhibit 4-12: Proposed Access Design

Existing Guardrail

A guardrail currently exists along the east side of Prince of Wales Drive at Access 2’s location. The existing guard rail would need to be shortened in order to accommodate the proposed north access.

Access Design

- As indicated within Section 4.1 the Car Dealership land use would result in the “worst-case” impact to the two accesses that are proposed to connect to Prince of Wales Drive. This is attributed to the large car-carrier design vehicle that would require access into, and through, the site given the prohibition of on-street loading/unloading on boundary streets such as Prince of Wales Drive and Waterbend Lane.
- Numerous iterations of the access design were prepared, and Appendix “G” presents the turning movements of a 25m long car carrier vehicle. The volume of traffic associated with these vehicles is anticipated to be less than 10 trips-per-week.

Clear Throat Length Requirements

Table 4-10 outlines the requirements for clear throat lengths at each access for each of the land use.

Table 4-10: Clear Throat Length Requirements

Land Use	Minimum Clear Throat Length Required (TAC Chapter 8 – Access, Table 8.9.3)
Auto Dealership (80,000 sqft)	Not Specified within TAC (15 metre minimum suggested based on other land uses)
Hotel (400 rooms)	30 metres
Office (80,000 sqft)	25 metres
Retail Plaza (70,000 sqft)	15 metres

Geometric Characteristics of the Access and Roadway Modification Approval

Geometric characteristics of the accesses are to be confirmed at the time of site plan application. It is understood that an RMA (Roadway Modification Approval) application will be required to accommodate the proposed accesses to Prince of Wales Drive.

4.9.3.3 Access Operations

The following operational characteristics are forecast to be exhibited by the proposed accesses in the horizon year 2030 (5 years after the development’s build-out). The values below represent a worst-case operational performance characteristic of the four land use alternatives that were analyzed:

Access 1 (South Access, WB-LT Prohibited):

- The southbound left-turn movement into the site is forecast to operate [assuming the 80,000 sqft office land use] with delays of up to 48 seconds in the morning peak hour, and a 95th percentile queue of that does not exceed 20 meters (or 3 car lengths). The design of the access illustrated in this document provides for sufficient storage length to accommodate (approximately 45m or 6 vehicles) which is more than sufficient to accommodate each of the four of the alternative land uses and the car carrier design vehicle length as illustrated in Exhibit 4-1.

- The westbound right turn movement out of the site is forecast to operate [assuming the 400 room hotel land use] with delays of up to 23 seconds in the morning peak hour; and a 95th percentile queue [assuming the 70,000 sqft retail plaza land use] of 6 metres (a single car length) during the afternoon peak hour of travel demand.

Access 2 (North access, RI-RO only):

- The westbound right turn movement out of the site is forecast to operate [assuming the 400 room hotel land use] with delays of up to 25 seconds in the morning peak hour, and a 95th percentile queue [assuming the 70,000 sqft retail plaza land use] of 11 metres (2 car lengths) during the afternoon peak hour of travel demand

4.9.3.4 Queue Spillover into the Site

The total traffic analysis indicates that in the worst-case scenario (70,000 sqft retail plaza), the 95th percentile queue leaving the proposed site will amount to 11 metres (2 car lengths).

The maximum volume of outbound traffic was forecast to be 185 vehicles [for the 70,000 sqft retail plaza]. Assuming a 40/60 traffic split between south and north access, respectively, this would translate up to 111 vehicles-per-hour, or only about 2 vehicles-per-minute during the peak hour of demand that would use Access 2 (North Access) to exit the site during the afternoon peak hour.

The development's accesses front the right turn lane from Prince of Wales Drive onto Hunt Club Road, which is prone to congestion and queuing. Motorists turning right out of either development's access onto Prince of Wales Drive during the peak hours of travel demand may need to rely on motorist courtesy gaps to enter the Prince of Wales northbound lane.

4.9.4 Traffic Analysis Conclusions

An evaluation of the total forecast traffic analyses presented in Section 4.9.2 indicated the following:

- Overall, the 2030 total traffic conditions exacerbate existing capacity constraints at the Prince of Wales Drive / Hunt Club Road intersection, however, this is primarily driven by the assumed growth in background (including adjacent proposed developments) traffic.
- An increase in northbound left-turning volumes during the afternoon peak hour of travel demand is forecast to result in a decline in the level of service particularly for the retail land use which generates more traffic than the other land uses. This could be addressed by consideration of adding additional signal time to northbound left-turn lane, but this would come at the expense of the more dominant southbound through movement.
- The advent of development's traffic is forecast to further increase delays and queues associated with the right turn movement from Prince of Wales Drive to Hunt Club Road. In the worst-case scenario [70,000 sqft retail plaza], the 95th percentile queues during the afternoon peak hour of travel demand are forecast to increase by 45 metres (from 327 m to 372 m), and delays are forecast to increase by about 70 seconds (from 343 seconds to 414 seconds).

- Both of the proposed site accesses are forecast to operate with acceptable levels of delay and queues internal to the site. However, motorists may be required to rely on other drivers' courtesy gaps in traffic along Prince of Wales Drive to exit the site.



5.0 SIGN-OFF

The undersigned report is submitted to the City of Ottawa staff. It is understood that this document is to be used in support of an application to amend the City's zoning by-law. Further revisions and additions to this document will be required as part of a future site plan application.

Should you have any questions or comments, please do not hesitate to contact us.

Yours truly,



Mr. Arthur Gordon B.A. P.Eng
Principal Engineer
Castleglenn Consultants Inc.

Mr. Andrey Kirillov B.Eng , EIT
Transportation Planner
Castleglenn Consultants Inc.

APPENDICIES

Appendix "A" – Certification Form for TIA Study Project Manager and Screening Form	"A"
Appendix "B" – Existing Traffic Counts, Signal Timings and Collision Information	"B"
Appendix "C" –Synchro Analysis Output Sheets Existing (2023).....	"C"
Appendix "D" – Proposed Access Concept	"D"
Appendix "E" – Synchro Analysis Output Sheets Background (2025 and 2030)	"E"
Appendix "F" – TDM Supportive Development Design and Infrastructure Checklist.....	"F"
Appendix "G" – Turning Movement Analysis at the Proposed Access	"G"
Appendix "H" – TDM Measures Checklist.....	"H"
Appendix "I" – Intersection MMLOS Analysis Sheets.....	"I"
Appendix "J" – Synchro Analysis Output Sheets Total (2025 and 2030)	"J"
Appendix "K" – City Staff Comment Responses.....	"K"

APPENDIX “A”

**CERTIFICATION FORM FOR TIA STUDY PROJECT MANAGER AND SCREENING
FORM**



TIA Plan Reports

Certification Form for TIA Study PM

On April 14, 2022, the Province's Bill 109 received Royal Assent providing legislative direction to implement the More Homes for Everyone Act, 2022 aiming to increase the supply of a range of housing options to make housing more affordable. Revisions have been made to the TIA guidelines to comply with Bill 109 and streamline the process for applicants and staff.

Individuals submitting TIA reports will be responsible for all aspects of development-related transportation assessment and reporting, and undertaking such work, in accordance and compliance with the City of Ottawa's Official Plan, the Transportation Master Plan and the Transportation Impact Assessment (2017) Guidelines.

By submitting the attached TIA report (and any associated documents) and signing this document, the individual acknowledges that they meet the four criteria listed below.

CERTIFICATION

- I have reviewed and have a sound understanding of the objectives, needs and requirements of the City of Ottawa's Official Plan, Transportation Master Plan and the Transportation Impact Assessment (2017) Guidelines; (Update effective July 2023)
- I have a sound knowledge of industry standard practice with respect to the preparation of transportation impact assessment reports, including multi modal level of service review;
- I have substantial experience (more than 5 years) in undertaking and delivering transportation impact studies (analysis, reporting and geometric design) with strong background knowledge in transportation planning, engineering or traffic operations; and
- I am either a licensed or registered¹ professional in good standing, whose field of expertise
 - is either transportation engineering
 - or transportation planning.

¹ License of registration body that oversees the profession is required to have a code of conduct and ethics guidelines that will ensure appropriate conduct and representation for transportation planning and/or transportation engineering works.

Dated at Ottawa this 1st day of December, 2023.
(City)

Name : Arthur Gordon

Professional title: Chairman Board of Directors

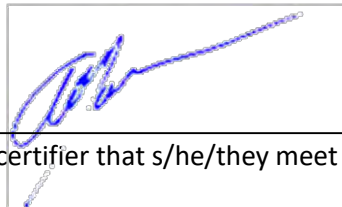

Signature of individual certifier that s/he/they meet the above criteria

Office Contact Information (Please Print)
Address: <u>200-2460 Lancaster Road</u>
City / Postal Code: <u>Ottawa, ON, K1B 4S5</u>
Telephone / Extension: <u>613-731-4052</u>
Email Address: <u>agordon@castleglenn.ca</u>

Stamp

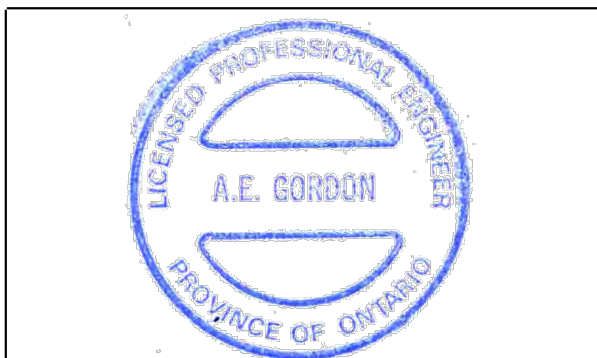

City of Ottawa 2017 TIA Guidelines Screening Form

1. Description of Proposed Development

Municipal Address	2175 Prince of Wales Drive
Description of Location	400 room hotel OR 80,000 sqft auto dealership OR 80,000 sqft office
Land Use Classification	OR 70,000 sqft retail plaza. Zoning: DR (Development Reserve)
Development Size (units)	400 rooms (Hotel); or
Development Size (m ²)	7,432 m ² auto dealership, or 7,432 m ² sqft office, or 6,503 sqft plaza
Number of Accesses and Locations	2 accesses to Prince of Wales Drive
Phase of Development	Single Phase
Buildout Year	2025

If available, please attach a sketch of the development or site plan to this form.

2. Trip Generation Trigger

Considering the Development's Land Use type and Size (as filled out in the previous section), please refer to the Trip Generation Trigger checks below.

Table notes:

1. Table 2, Table 3 & Table 4 TRANS Trip Generation Manual
2. Institute of Transportation Engineers (ITE) Trip Generation Manual 11.1 Ed.

Land Use Type	Minimum Development Size
Single-family homes	60 units
Multi-Use Family (Low-Rise) ¹	90 units
Multi-Use Family (High-Rise) ¹	150 units
Office ²	1,400 m ²
Industrial ²	7,000 m ²
Fast-food restaurant or coffee shop ²	110 m ²
Destination retail ²	1,800 m ²
Gas station or convenience market ²	90 m ²

If the proposed development size is greater than the sizes identified above, the Trip Generation Trigger is satisfied.

3. Location Triggers

	Yes	No
Does the development propose a new driveway to a boundary street that is designated as part of the City’s Transit Priority Network, Rapid Transit network or Cross-Town Bikeways?	X	
Is the development in a Hub, a Protected Major Transit Station Area (PMTSA), or a Design Priority Area (DPA)? ²		X

If any of the above questions were answered with ‘Yes,’ the Location Trigger is satisfied.

4. Safety Triggers

	Yes	No
Are posted speed limits on a boundary street 80 km/hr or greater?		X
Are there any horizontal/vertical curvatures on a boundary street limits sight lines at a proposed driveway?		X
Is the proposed driveway within the area of influence of an adjacent traffic signal or roundabout (i.e. within 300 m of intersection in rural conditions, or within 150 m of intersection in urban/ suburban conditions)?	X	
Is the proposed driveway within auxiliary lanes of an intersection?	X	
Does the proposed driveway make use of an existing median break that serves an existing site?		X
Is there is a documented history of traffic operations or safety concerns on the boundary streets within 500 m of the development?	X	
Does the development include a drive-thru facility?		X

If any of the above questions were answered with ‘Yes,’ the Safety Trigger is satisfied.

• Summary

	Yes	No
Does the development satisfy the results of screening?	X	
Does the development satisfy the Location Trigger?	X	
Does the development satisfy the Safety Trigger?	X	

² Hubs are identified in Schedules B1 to B8 of the City of Ottawa Official Plan. PMTSAs are identified in Schedule C1 of the Official Plan. DPAs are identified in Schedule C7A and C7B of the Official. See Chapter 4 for a list of City of Ottawa Planning and Engineering documents that support the completion of TIA.

If none of the triggers are satisfied, the TIA Study is complete. If one or more of the triggers is satisfied, the TIA Study must continue into the next stage (Screening and Scoping).

APPENDIX “B”

**EXISTING TRAFFIC COUNTS, SIGNAL TIMINGS AND COLLISION
INFORMATION**



Transportation Services - Traffic Services

Turning Movement Count - Study Results

DEAKIN ST @ PRINCE OF WALES DR

Survey Date: Tuesday, November 26, 2019

WO No: 39111

Start Time: 07:00

Device: Miovision

Full Study Diagram

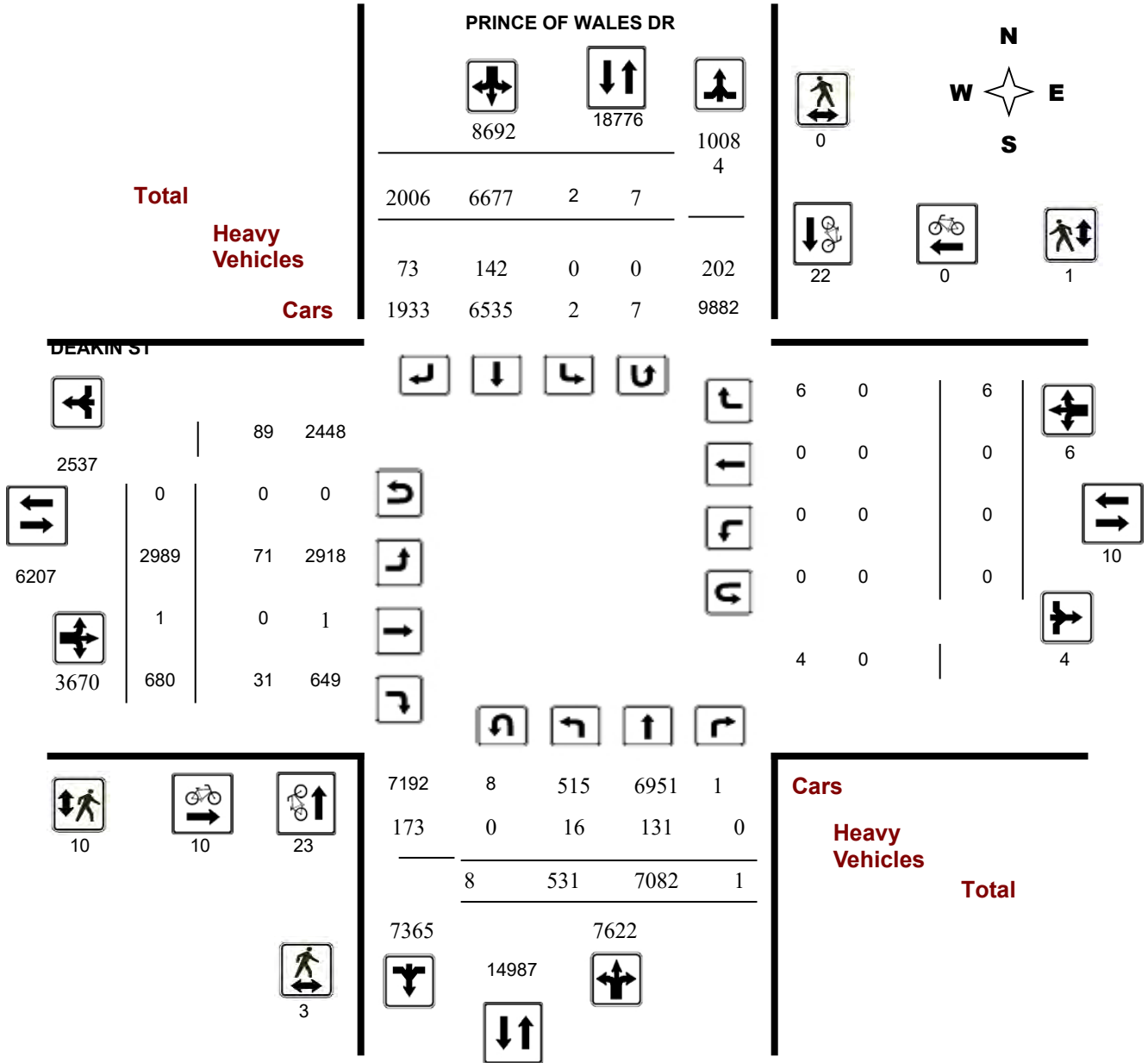

Turning Movement Count - Study Results

DEAKIN ST @ PRINCE OF WALES DR

Survey Date: Tuesday, November 26, 2019

WO No: 39111

Start Time: 07:00

Device: Miovision

Full Study Peak Hour Diagram

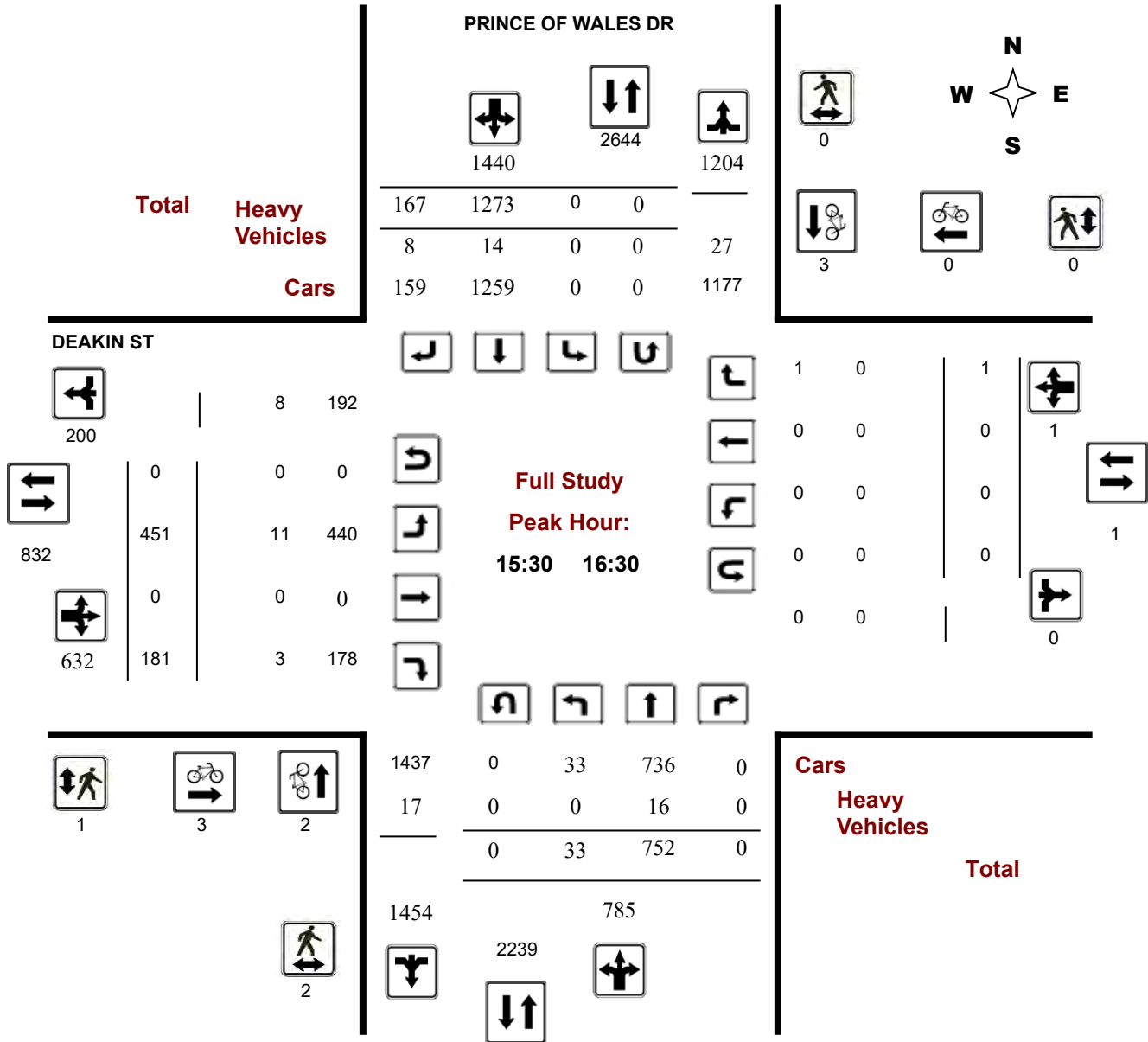



Transportation Services - Traffic Services

Turning Movement Count - Peak Hour Diagram

DEAKIN ST @ PRINCE OF WALES DR

Survey Date: Tuesday, November 26, 2019

Start Time: 07:00

WO No: 39111

Device: Miovision

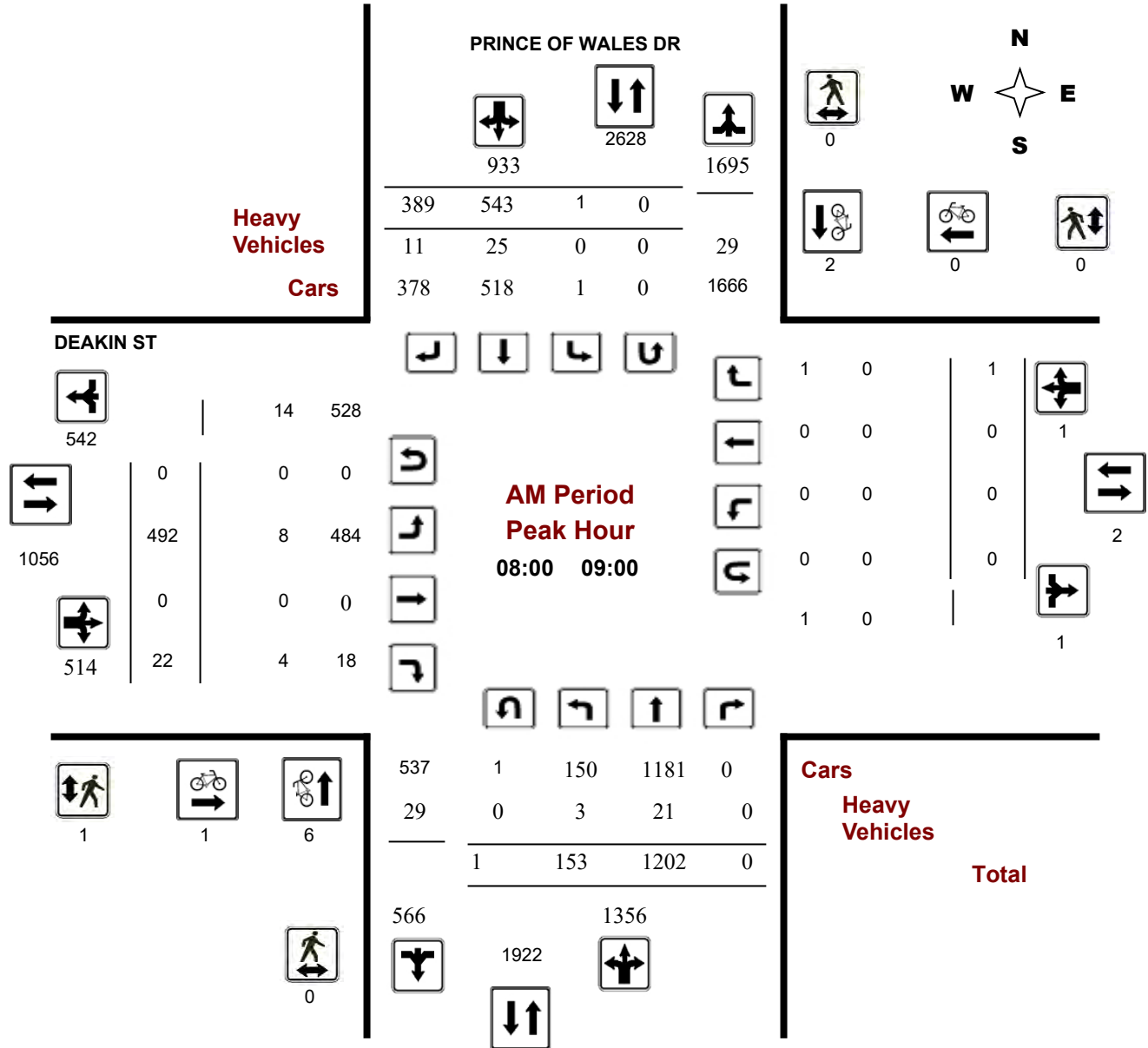



Transportation Services - Traffic Services

Turning Movement Count - Peak Hour Diagram

DEAKIN ST @ PRINCE OF WALES DR

Survey Date: Tuesday, November 26, 2019

Start Time: 07:00

WO No: 39111

Device: Miovision

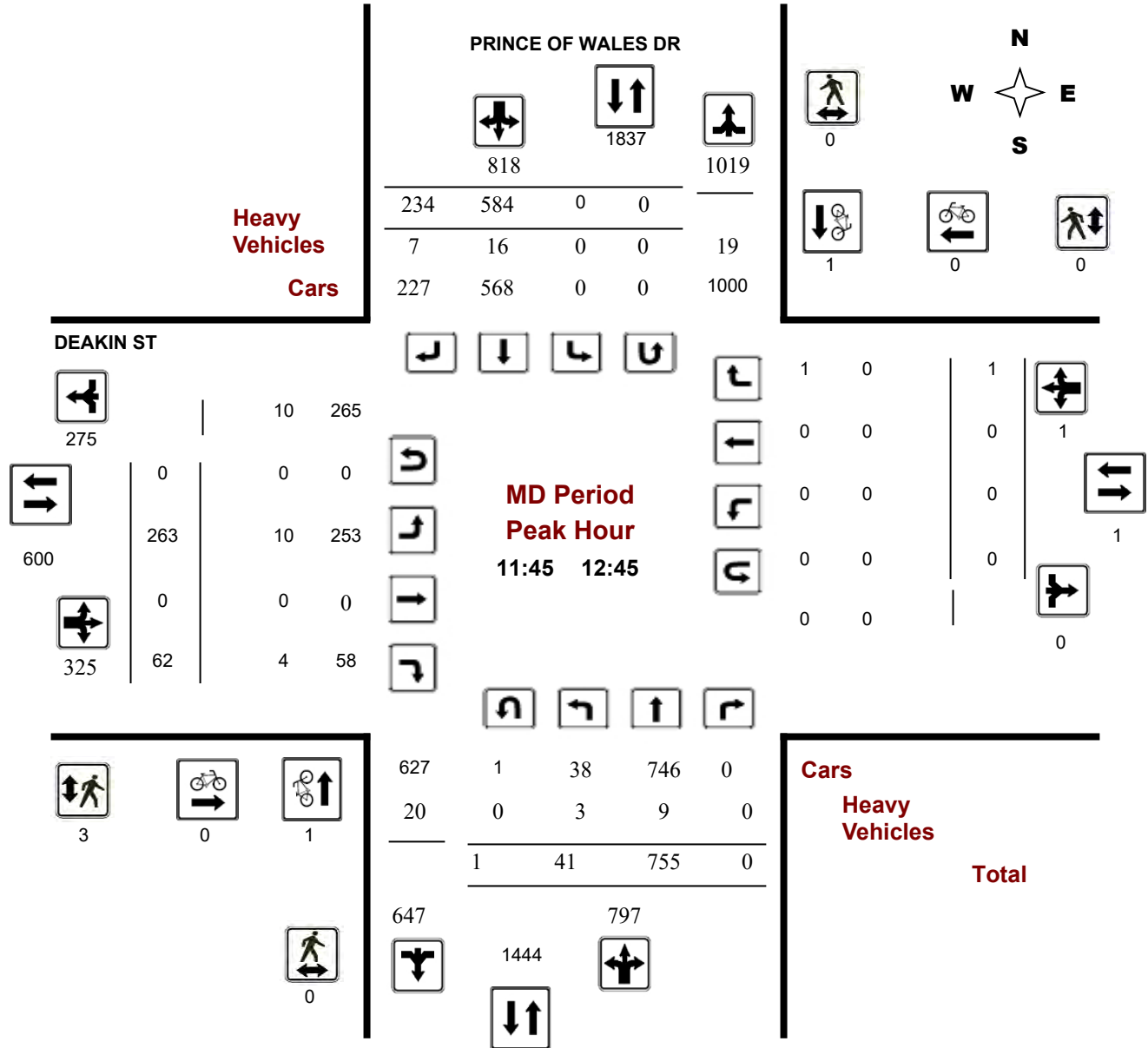

Comments



Transportation Services - Traffic Services

Turning Movement Count - Peak Hour Diagram

DEAKIN ST @ PRINCE OF WALES DR

Survey Date: Tuesday, November 26, 2019

Start Time: 07:00

WO No: 39111

Device: Miovision

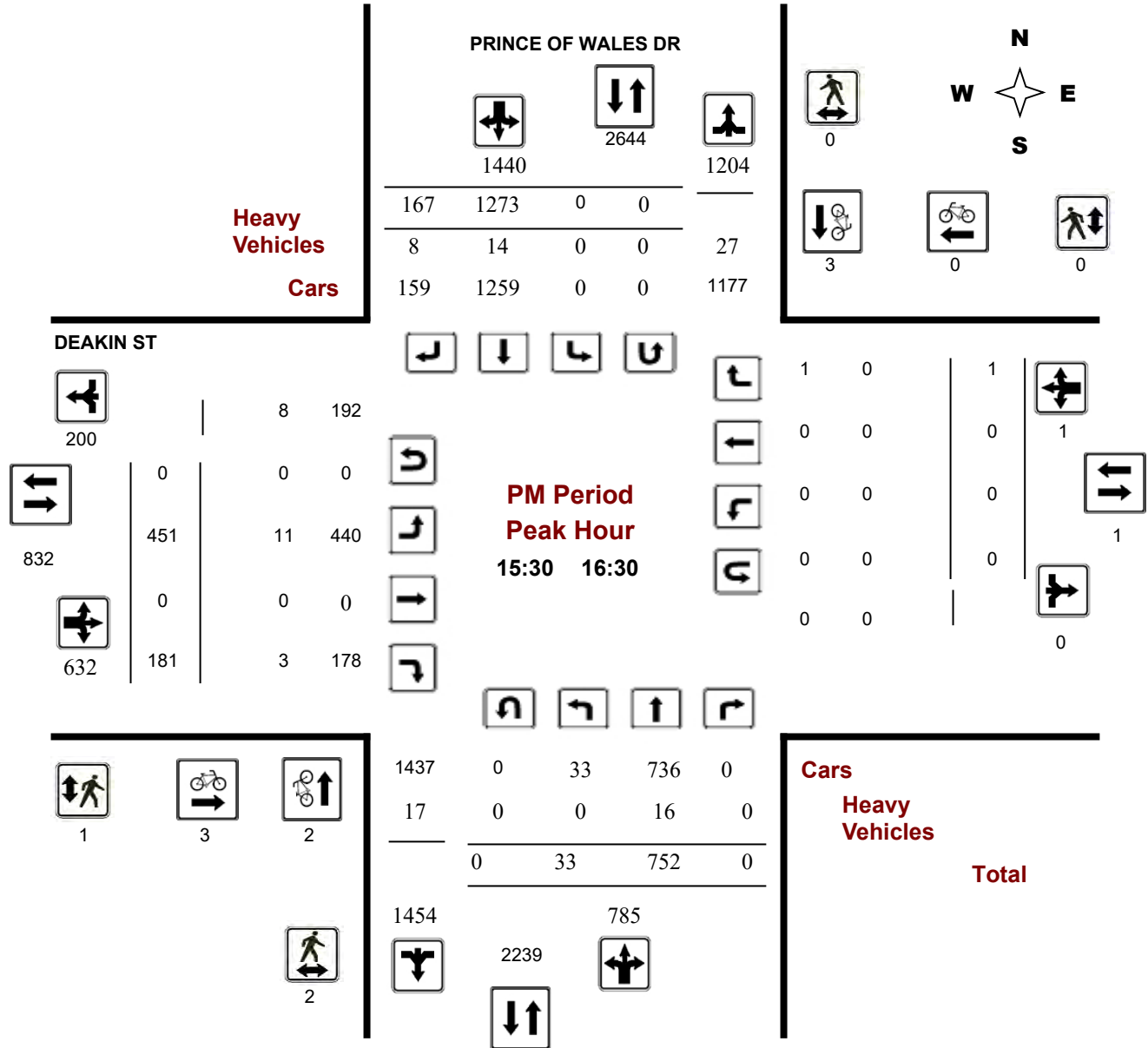



Transportation Services - Traffic Services

Turning Movement Count - Study Results

DEAKIN ST @ PRINCE OF WALES DR

Survey Date: Tuesday, November 26, 2019

WO No: 39111

Start Time: 07:00

Device: Miovision

Full Study Summary (8 HR Standard)

Survey Date: Tuesday, November 26, 2019

Total Observed U-Turns

AADT Factor

Northbound: 8 Southbound: 7
 Eastbound: 0 Westbound: 0

1.00

Period	PRINCE OF WALES DR										DEAKIN ST										Grand Total
	Northbound					Southbound					Eastbound					Westbound					
	LT	ST	RT	NB TOT	STR TOT	LT	ST	RT	SB TOT	STR TOT	LT	ST	RT	EB TOT	STR TOT	LT	ST	RT	WB TOT	STR TOT	
07:00 08:00	97	1231	0	1328	2180	0	554	298	852	2180	510	0	23	533	2180	0	0	1	1	534	2714
08:00 09:00	153	1202	0	1355	2288	1	543	389	933	2288	492	0	22	514	2288	0	0	1	1	515	2803
09:00 10:00	116	1116	1	1233	2107	0	521	353	874	2107	247	0	21	268	2107	0	0	2	2	270	2377
11:30 12:30	34	719	0	753	1560	0	558	249	807	1560	268	0	61	329	1560	0	0	1	1	330	1890
12:30 13:30	45	636	0	681	1618	0	671	266	937	1618	197	0	51	248	1618	0	0	0	0	248	1866
15:00 16:00	30	749	0	779	2279	1	1324	175	1500	2279	385	1	133	519	2279	0	0	1	1	520	2799
16:00 17:00	28	764	0	792	2118	0	1184	142	1326	2118	480	0	211	691	2118	0	0	0	0	691	2809
17:00 18:00	28	665	0	693	2149	0	1322	134	1456	2149	410	0	158	568	2149	0	0	0	0	568	2717
Sub Total	531	7082	1	7614	16299	2	6677	2006	8685	16299	2989	1	680	3670	16299	0	0	6	6	3676	19975
U Turns				8				7	15				0				0	0	15		
Total	531	7082	1	7622	16314	2	6677	2006	8692	16314	2989	1	680	3670	16314	0	0	6	6	3676	19990
EQ 12Hr	738	9844	1	10595	22676	3	9281	2788	12082	22676	4155	1	945	5101	22676	0	0	8	8	5110	27786
Note: These values are calculated by multiplying the totals by the appropriate expansion factor.														1.39							
AVG 12Hr	738	9844	1	10595	22676	3	12158	3653	12082	22676	4155	1	945	5101	22676	0	0	8	8	5110	27786
Note: These volumes are calculated by multiplying the Equivalent 12 hr. totals by the AADT factor.														1.00							
AVG 24Hr	967	12896	1	13879	29706	4	15927	4785	15827	29706	5443	1	1238	6682	29706	0	0	10	10	6694	36400
Note: These volumes are calculated by multiplying the Average Daily 12 hr. totals by 12 to 24 expansion factor.														1.31							
Note: U-Turns provided for approach totals. Refer to 'U-Turn' Report for specific breakdown.																					



Transportation Services - Traffic Services

Turning Movement Count - Study Results

DEAKIN ST @ PRINCE OF WALES DR

Survey Date: Tuesday, November 26, 2019

WO No: 39111

Start Time: 07:00

Device: Miovision

Full Study 15 Minute Increments

PRINCE OF WALES DR

DEAKIN ST

Northbound

Southbound

Eastbound

Westbound

Time Period	LT	ST	RT	N TOT	LT	ST	RT	S TOT	STR TOT	LT	ST	RT	E TOT	LT	ST	RT	W TOT	STR TOT	Grand Total
07:00 07:15	23	294	0	317	0	120	60	180	497	104	0	8	112	0	0	1	1	113	610
07:15 07:30	18	332	0	350	0	151	76	227	577	131	0	5	136	0	0	0	0	136	713
07:30 07:45	19	319	0	338	0	135	75	210	548	157	0	6	163	0	0	0	0	163	711
07:45 08:00	37	286	0	323	0	148	87	235	558	118	0	4	122	0	0	0	0	122	680
08:00 08:15	34	302	0	336	0	122	79	201	537	108	0	4	112	0	0	0	0	112	649
08:15 08:30	34	271	0	305	0	151	96	247	552	153	0	4	157	0	0	0	0	157	709
08:30 08:45	43	301	0	345	1	134	99	234	579	118	0	9	127	0	0	0	0	127	706
08:45 09:00	42	328	0	370	0	136	115	251	621	113	0	5	118	0	0	1	1	119	740
09:00 09:15	37	294	1	332	0	112	98	210	542	79	0	6	85	0	0	0	0	85	627
09:15 09:30	30	302	0	332	0	129	88	217	549	69	0	8	77	0	0	2	2	79	628
09:30 09:45	28	294	0	322	0	131	80	211	533	52	0	3	55	0	0	0	0	55	588
09:45 10:00	21	226	0	247	0	149	87	236	483	47	0	4	51	0	0	0	0	51	534
11:30 11:45	4	146	0	150	0	146	62	208	358	52	0	13	65	0	0	0	0	65	423
11:45 12:00	9	198	0	207	0	130	60	190	397	70	0	22	92	0	0	0	0	92	489
12:00 12:15	11	182	0	194	0	148	70	218	412	74	0	17	91	0	0	0	0	91	503
12:15 12:30	10	193	0	203	0	134	57	191	394	72	0	9	81	0	0	1	1	82	476
12:30 12:45	11	182	0	193	0	172	47	219	412	47	0	14	61	0	0	0	0	61	473
12:45 13:00	11	173	0	184	0	173	73	246	430	46	0	10	56	0	0	0	0	56	486
13:00 13:15	14	149	0	163	0	158	83	241	404	61	0	16	77	0	0	0	0	77	481
13:15 13:30	9	132	0	143	0	168	63	232	375	43	0	11	54	0	0	0	0	54	429
15:00 15:15	6	207	0	213	1	327	48	378	591	98	0	33	131	0	0	0	0	131	722
15:15 15:30	6	183	0	190	0	328	40	371	561	77	1	26	104	0	0	0	0	104	665
15:30 15:45	9	192	0	201	0	350	48	398	599	109	0	35	144	0	0	0	0	144	743
15:45 16:00	9	167	0	176	0	319	39	358	534	101	0	39	140	0	0	1	1	141	675
16:00 16:15	5	201	0	206	0	329	41	370	576	118	0	57	175	0	0	0	0	175	751
16:15 16:30	10	192	0	202	0	275	39	314	516	123	0	50	173	0	0	0	0	173	689
16:30 16:45	8	189	0	197	0	280	37	317	514	111	0	54	165	0	0	0	0	165	679
16:45 17:00	5	182	0	188	0	300	25	326	514	128	0	50	178	0	0	0	0	178	692
17:00 17:15	6	173	0	179	0	361	28	389	568	111	0	57	168	0	0	0	0	168	736
17:15 17:30	11	166	0	178	0	335	30	365	543	128	0	49	177	0	0	0	0	177	720
17:30 17:45	7	165	0	172	0	321	38	359	531	89	0	28	117	0	0	0	0	117	648
17:45 18:00	4	161	0	166	0	305	38	343	509	82	0	24	106	0	0	0	0	106	615
Total:	531	7082	1	7622	2	6677	2006	8692	16314	2989	1	680	3670	0	0	6	6	3676	19,990

Note: U-Turns are included in Totals.



Transportation Services - Traffic Services

Turning Movement Count - Study Results

DEAKIN ST @ PRINCE OF WALES DR

Survey Date: Tuesday, November 26, 2019

WO No: 39111

Start Time: 07:00

Device: Miovision

Full Study Cyclist Volume

PRINCE OF WALES DR

DEAKIN ST

Time Period	Northbound	Southbound	Street Total	Eastbound	Westbound	Street Total	Grand Total
07:00 07:15	2	0	2	1	0	1	3
07:15 07:30	2	1	3	1	0	1	4
07:30 07:45	2	0	2	0	0	0	2
07:45 08:00	1	2	3	0	0	0	3
08:00 08:15	1	1	2	0	0	0	2
08:15 08:30	3	1	4	1	0	1	5
08:30 08:45	1	0	1	0	0	0	1
08:45 09:00	1	0	1	0	0	0	1
09:00 09:15	0	1	1	1	0	1	2
09:15 09:30	0	0	0	0	0	0	0
09:30 09:45	0	0	0	0	0	0	0
09:45 10:00	0	0	0	0	0	0	0
11:30 11:45	1	0	1	0	0	0	1
11:45 12:00	0	0	0	0	0	0	0
12:00 12:15	1	1	2	0	0	0	2
12:15 12:30	0	0	0	0	0	0	0
12:30 12:45	0	0	0	0	0	0	0
12:45 13:00	0	0	0	0	0	0	0
13:00 13:15	2	0	2	0	0	0	2
13:15 13:30	0	2	2	0	0	0	2
15:00 15:15	0	1	1	1	0	1	2
15:15 15:30	1	0	1	0	0	0	1
15:30 15:45	0	0	0	2	0	2	2
15:45 16:00	0	1	1	0	0	0	1
16:00 16:15	1	1	2	1	0	1	3
16:15 16:30	1	1	2	0	0	0	2
16:30 16:45	1	3	4	1	0	1	5
16:45 17:00	0	2	2	0	0	0	2
17:00 17:15	1	0	1	0	0	0	1
17:15 17:30	0	1	1	0	0	0	1
17:30 17:45	0	2	2	0	0	0	2
17:45 18:00	1	1	2	1	0	1	3
Total	23	22	45	10	0	10	55



Transportation Services - Traffic Services

Turning Movement Count - Study Results

DEAKIN ST @ PRINCE OF WALES DR

Survey Date: Tuesday, November 26, 2019

WO No: 39111

Start Time: 07:00

Device: Miovision

Full Study Pedestrian Volume

PRINCE OF WALES DR

DEAKIN ST

Time Period	NB Approach (E or W Crossing)	SB Approach (E or W Crossing)	Total	EB Approach (N or S Crossing)	WB Approach (N or S Crossing)	Total	Grand Total
07:00 07:15	0	0	0	0	0	0	0
07:15 07:30	0	0	0	0	0	0	0
07:30 07:45	0	0	0	0	0	0	0
07:45 08:00	0	0	0	1	0	1	1
08:00 08:15	0	0	0	0	0	0	0
08:15 08:30	0	0	0	0	0	0	0
08:30 08:45	0	0	0	0	0	0	0
08:45 09:00	0	0	0	1	0	1	1
09:00 09:15	0	0	0	1	0	1	1
09:15 09:30	0	0	0	0	0	0	0
09:30 09:45	0	0	0	0	0	0	0
09:45 10:00	0	0	0	0	0	0	0
11:30 11:45	0	0	0	0	0	0	0
11:45 12:00	0	0	0	0	0	0	0
12:00 12:15	0	0	0	1	0	1	1
12:15 12:30	0	0	0	1	0	1	1
12:30 12:45	0	0	0	1	0	1	1
12:45 13:00	0	0	0	0	0	0	0
13:00 13:15	0	0	0	0	0	0	0
13:15 13:30	0	0	0	0	0	0	0
15:00 15:15	0	0	0	1	0	1	1
15:15 15:30	0	0	0	0	0	0	0
15:30 15:45	1	0	1	1	0	1	2
15:45 16:00	1	0	1	0	0	0	1
16:00 16:15	0	0	0	0	0	0	0
16:15 16:30	0	0	0	0	0	0	0
16:30 16:45	0	0	0	0	0	0	0
16:45 17:00	0	0	0	1	0	1	1
17:00 17:15	1	0	1	0	1	1	2
17:15 17:30	0	0	0	0	0	0	0
17:30 17:45	0	0	0	1	0	1	1
17:45 18:00	0	0	0	0	0	0	0
Total	3	0	3	10	1	11	14



Transportation Services - Traffic Services

Turning Movement Count - Study Results

DEAKIN ST @ PRINCE OF WALES DR

Survey Date: Tuesday, November 26, 2019

WO No: 39111

Start Time: 07:00

Device: Miovision

Full Study Heavy Vehicles

PRINCE OF WALES DR

DEAKIN ST

Northbound Southbound Eastbound Westbound

Time Period	Northbound			N TOT	Southbound			S TOT	STR TOT	Eastbound			E TOT	Westbound			W TOT	STR TOT	Grand Total
	LT	ST	RT		LT	ST	RT			LT	ST	RT		LT	ST	RT			
07:00 07:15	1	3	0	16	0	8	1	16	32	4	0	4	10	0	0	0	0	10	21
07:15 07:30	0	3	0	9	0	4	3	14	23	4	0	2	9	0	0	0	0	9	16
07:30 07:45	0	4	0	10	0	5	0	13	23	4	0	1	5	0	0	0	0	5	14
07:45 08:00	0	2	0	6	0	2	0	7	13	3	0	2	5	0	0	0	0	5	9
08:00 08:15	1	2	0	9	0	4	1	7	16	0	0	2	4	0	0	0	0	4	10
08:15 08:30	0	8	0	15	0	7	2	21	36	4	0	0	6	0	0	0	0	6	21
08:30 08:45	2	3	0	16	0	9	5	19	35	2	0	2	11	0	0	0	0	11	23
08:45 09:00	0	8	0	13	0	5	3	18	31	2	0	0	5	0	0	0	0	5	18
09:00 09:15	0	8	0	17	0	8	2	20	37	2	0	1	5	0	0	0	0	5	21
09:15 09:30	1	7	0	15	0	7	5	22	37	3	0	0	9	0	0	0	0	9	23
09:30 09:45	2	8	0	18	0	8	5	23	41	2	0	0	9	0	0	0	0	9	25
09:45 10:00	2	7	0	16	0	5	5	22	38	5	0	2	14	0	0	0	0	14	26
11:30 11:45	1	5	0	13	0	6	3	14	27	0	0	1	5	0	0	0	0	5	16
11:45 12:00	0	4	0	11	0	3	3	12	23	2	0	4	9	0	0	0	0	9	16
12:00 12:15	2	4	0	11	0	5	1	12	23	2	0	0	5	0	0	0	0	5	14
12:15 12:30	1	0	0	5	0	4	2	11	16	5	0	0	8	0	0	0	0	8	12
12:30 12:45	0	1	0	5	0	4	1	7	12	1	0	0	2	0	0	0	0	2	7
12:45 13:00	0	3	0	9	0	6	2	13	22	2	0	0	4	0	0	0	0	4	13
13:00 13:15	1	2	0	8	0	3	2	10	18	3	0	2	8	0	0	0	0	8	13
13:15 13:30	1	3	0	9	0	4	5	15	24	3	0	1	10	0	0	0	0	10	17
15:00 15:15	0	6	0	10	0	4	3	13	23	0	0	0	3	0	0	0	0	3	13
15:15 15:30	0	4	0	9	0	5	0	11	20	2	0	0	2	0	0	0	0	2	11
15:30 15:45	0	5	0	10	0	4	1	14	24	4	0	1	6	0	0	0	0	6	15
15:45 16:00	0	1	0	8	0	6	0	9	17	2	0	1	3	0	0	0	0	3	10
16:00 16:15	0	5	0	8	0	2	1	10	18	2	0	1	4	0	0	0	0	4	11
16:15 16:30	0	5	0	7	0	2	6	16	23	3	0	0	9	0	0	0	0	9	16
16:30 16:45	1	3	0	8	0	1	5	11	19	2	0	3	11	0	0	0	0	11	15
16:45 17:00	0	4	0	6	0	2	0	7	13	1	0	0	1	0	0	0	0	1	7
17:00 17:15	0	4	0	6	0	2	0	6	12	0	0	0	0	0	0	0	0	0	6
17:15 17:30	0	5	0	8	0	3	3	11	19	0	0	0	3	0	0	0	0	3	11
17:30 17:45	0	2	0	6	0	3	1	8	14	2	0	1	4	0	0	0	0	4	9
17:45 18:00	0	2	0	3	0	1	2	5	8	0	0	0	2	0	0	0	0	2	5
Total: None	16	131	0	320	0	142	73	417	737	71	0	31	191	0	0	0	0	191	464



Transportation Services - Traffic Services

Turning Movement Count - Study Results

DEAKIN ST @ PRINCE OF WALES DR

Survey Date: Tuesday, November 26, 2019

WO No: 39111

Start Time: 07:00

Device: Miovision

Full Study 15 Minute U-Turn Total

PRINCE OF WALES DR

DEAKIN ST

Time Period		Northbound U-Turn Total	Southbound U-Turn Total	Eastbound U-Turn Total	Westbound U-Turn Total	Total
07:00	07:15	0	0	0	0	0
07:15	07:30	0	0	0	0	0
07:30	07:45	0	0	0	0	0
07:45	08:00	0	0	0	0	0
08:00	08:15	0	0	0	0	0
08:15	08:30	0	0	0	0	0
08:30	08:45	1	0	0	0	1
08:45	09:00	0	0	0	0	0
09:00	09:15	0	0	0	0	0
09:15	09:30	0	0	0	0	0
09:30	09:45	0	0	0	0	0
09:45	10:00	0	0	0	0	0
11:30	11:45	0	0	0	0	0
11:45	12:00	0	0	0	0	0
12:00	12:15	1	0	0	0	1
12:15	12:30	0	0	0	0	0
12:30	12:45	0	0	0	0	0
12:45	13:00	0	0	0	0	0
13:00	13:15	0	0	0	0	0
13:15	13:30	2	1	0	0	3
15:00	15:15	0	2	0	0	2
15:15	15:30	1	3	0	0	4
15:30	15:45	0	0	0	0	0
15:45	16:00	0	0	0	0	0
16:00	16:15	0	0	0	0	0
16:15	16:30	0	0	0	0	0
16:30	16:45	0	0	0	0	0
16:45	17:00	1	1	0	0	2
17:00	17:15	0	0	0	0	0
17:15	17:30	1	0	0	0	1
17:30	17:45	0	0	0	0	0
17:45	18:00	1	0	0	0	1
Total		8	7	0	0	15

Transportation Services - Traffic Services

Turning Movement Count - Study Results

PRINCE OF WALES DR @ WEST HUNT CLUB RD

Survey Date: Monday, February 10, 2020

WO No: 39445

Start Time: 07:00

Device: Miovision

Full Study Diagram

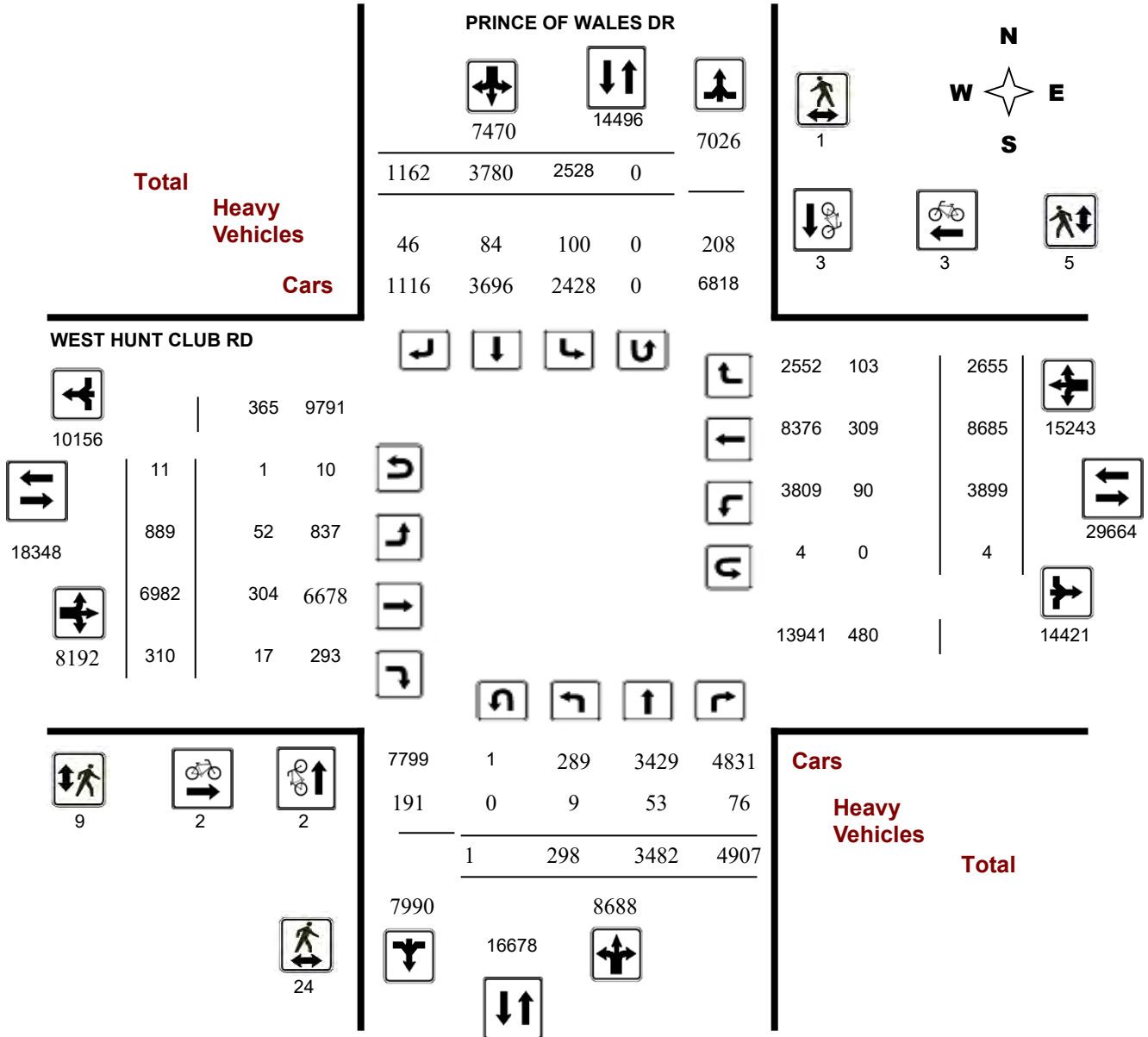

Turning Movement Count - Study Results

PRINCE OF WALES DR @ WEST HUNT CLUB RD

Survey Date: Monday, February 10, 2020

WO No: 39445

Start Time: 07:00

Device: Miovision

Full Study Peak Hour Diagram

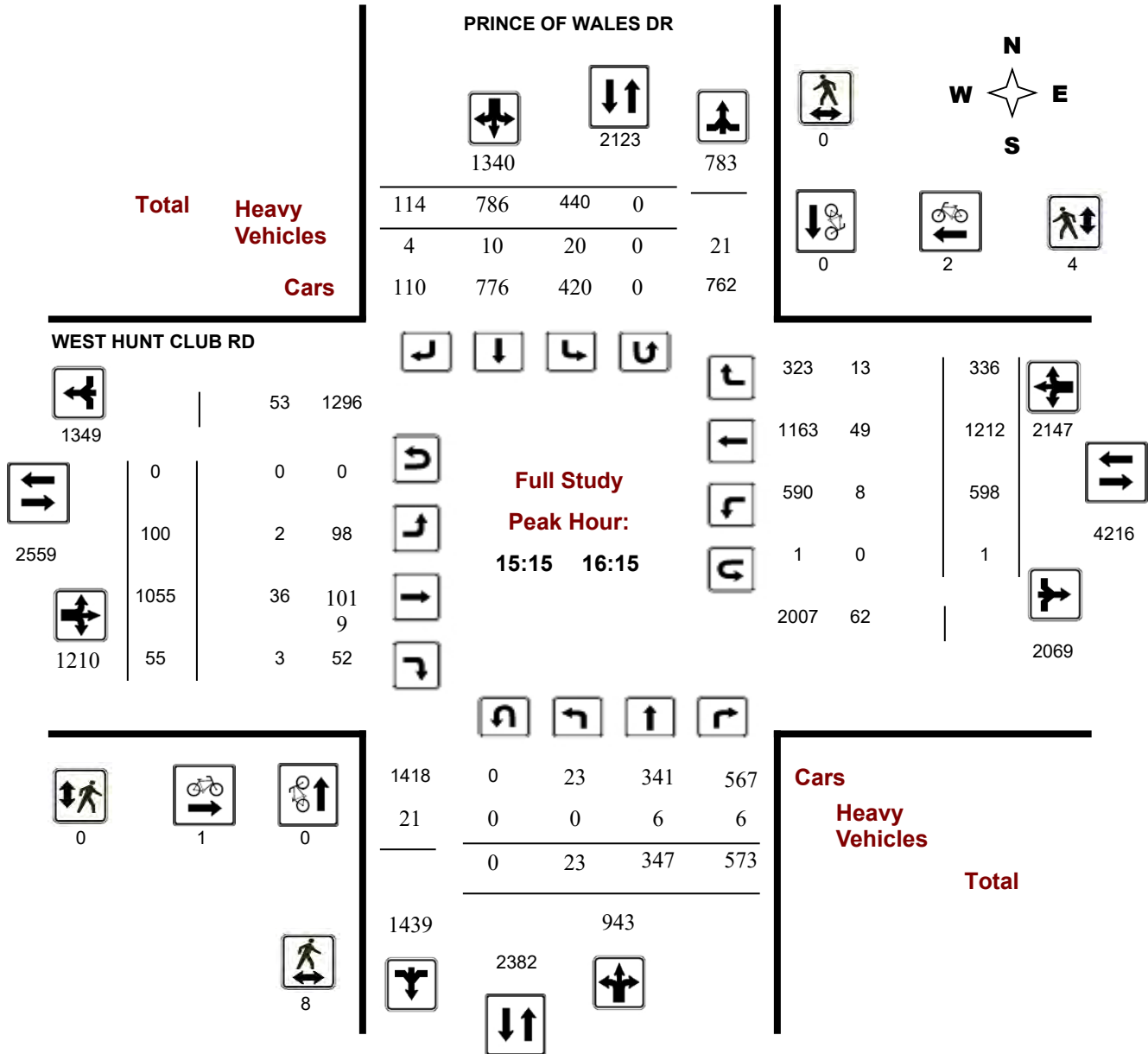

Turning Movement Count - Peak Hour Diagram

PRINCE OF WALES DR @ WEST HUNT CLUB RD

Survey Date: Monday, February 10, 2020

Start Time: 07:00

WO No: 39445

Device: Miovision

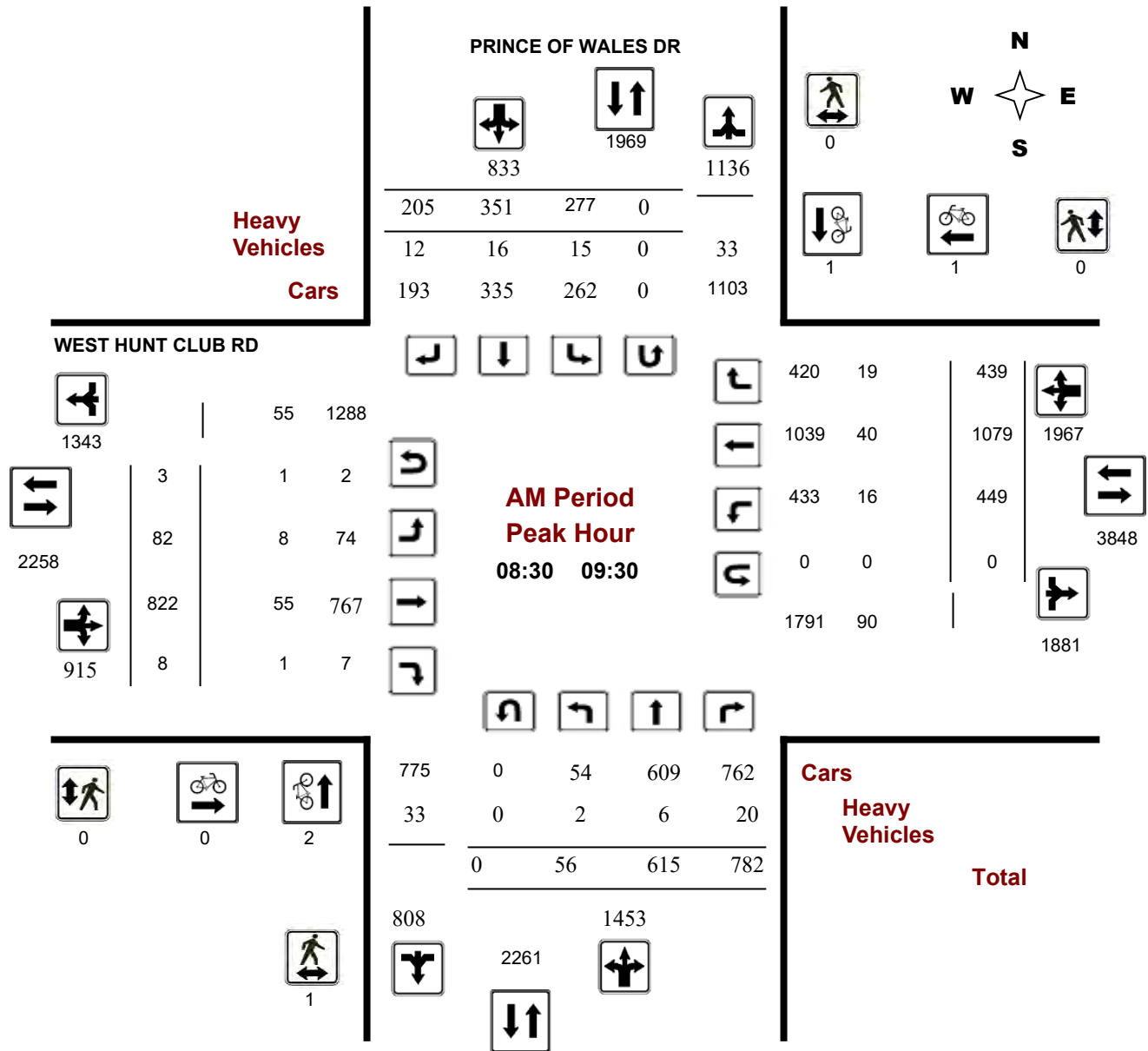



Transportation Services - Traffic Services

Turning Movement Count - Peak Hour Diagram

PRINCE OF WALES DR @ WEST HUNT CLUB RD

Survey Date: Monday, February 10, 2020

Start Time: 07:00

WO No: 39445

Device: Miovision

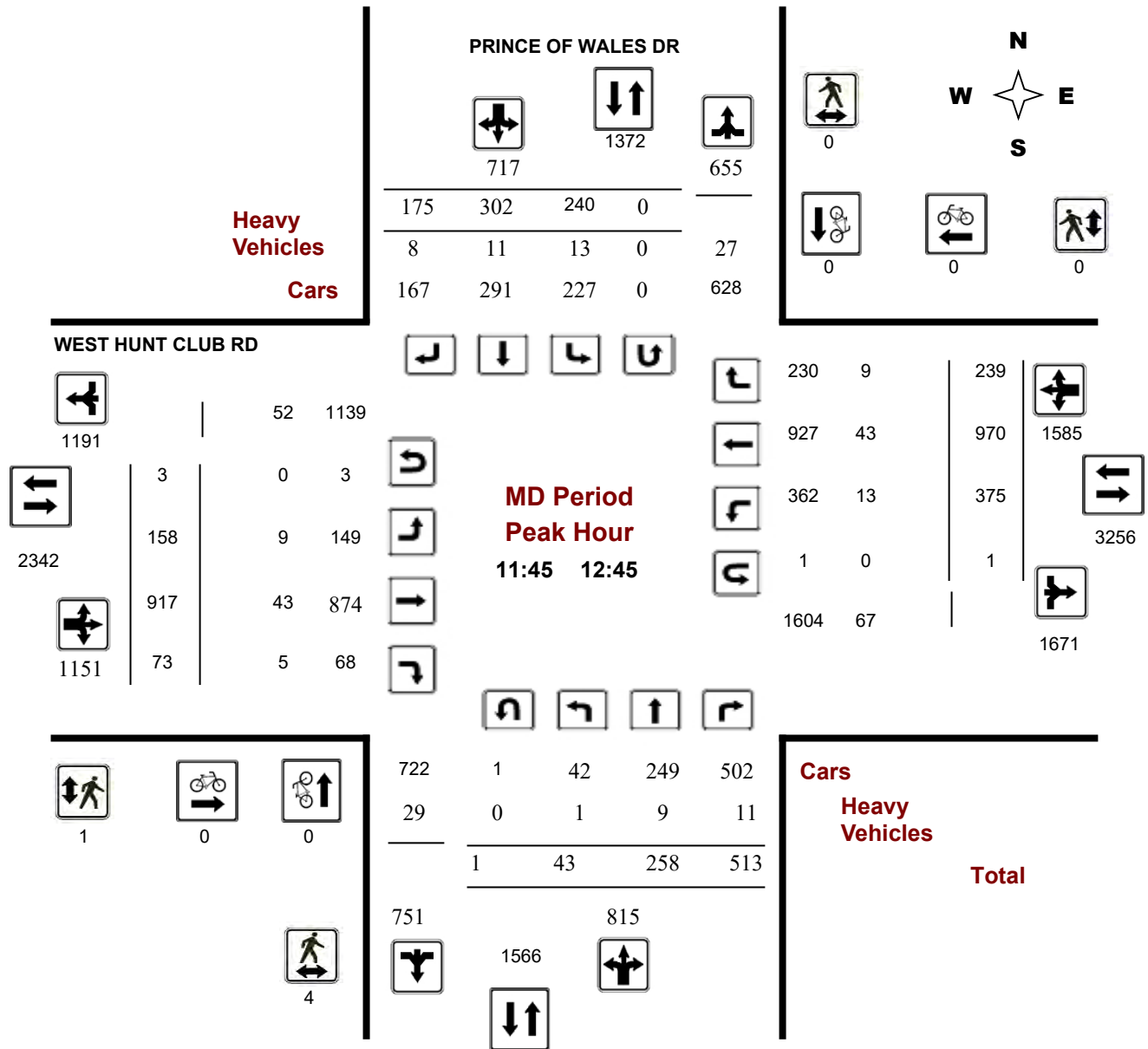

Turning Movement Count - Peak Hour Diagram

PRINCE OF WALES DR @ WEST HUNT CLUB RD

Survey Date: Monday, February 10, 2020

Start Time: 07:00

WO No: 39445

Device: Miovision

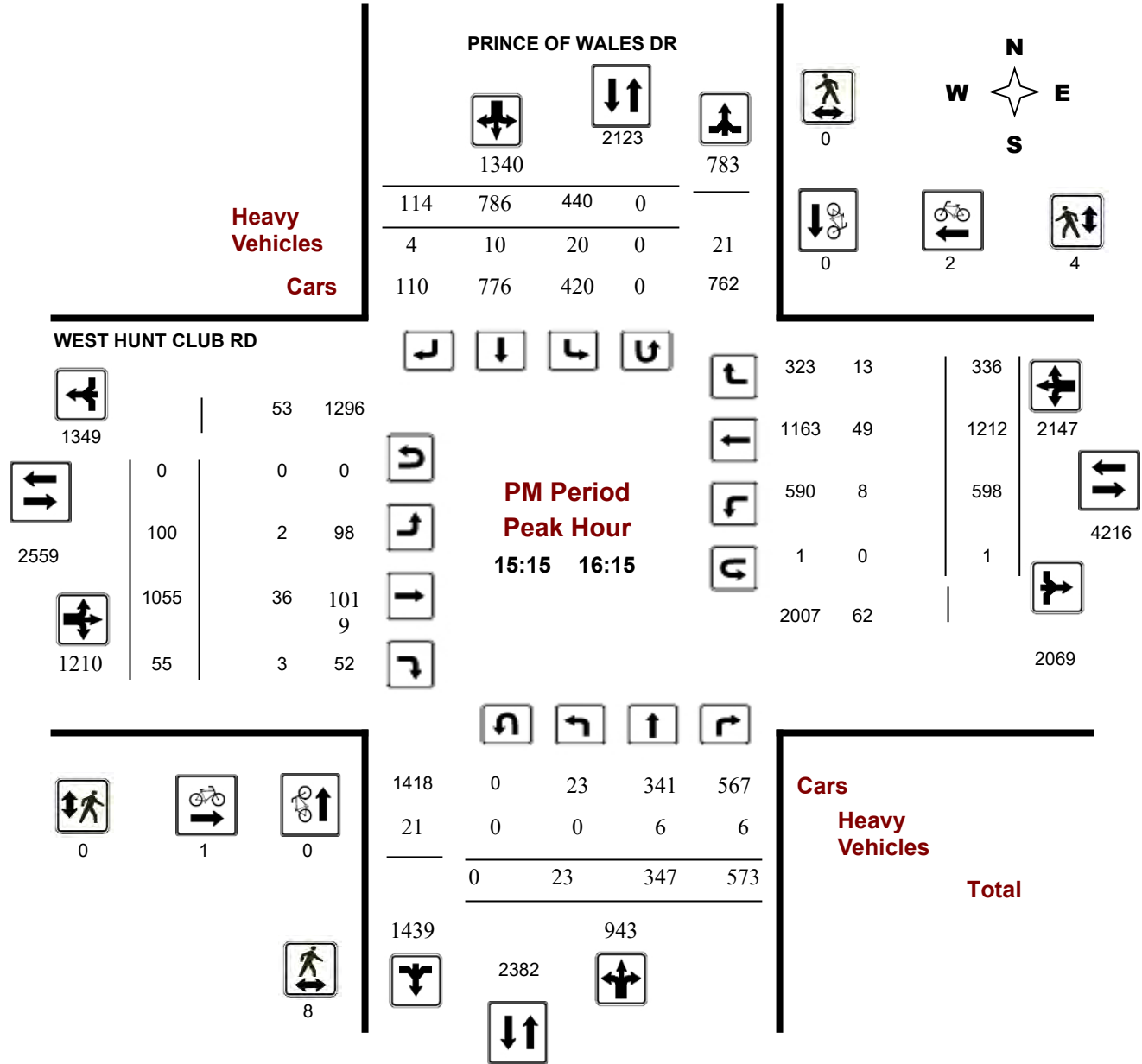

Comments



Transportation Services - Traffic Services

Turning Movement Count - Study Results

PRINCE OF WALES DR @ WEST HUNT CLUB RD

Survey Date: Monday, February 10, 2020

WO No: 39445

Start Time: 07:00

Device: Miovision

Full Study Summary (8 HR Standard)

Survey Date: Monday, February 10, 2020

Total Observed U-Turns

AADT Factor

Northbound: 1 Southbound: 0
 Eastbound: 11 Westbound: 4

1.00

PRINCE OF WALES DR

WEST HUNT CLUB RD

Period	Northbound					Southbound					Eastbound					Westbound			STR TOT	Grand Total
	LT	ST	RT	NB TOT	LT	ST	RT	SB TOT	STR TOT	LT	ST	RT	EB TOT	LT	ST	RT	WB TOT			
07:00 08:00	22	666	721	1409	208	319	142	669	2078	68	796	12	876	416	999	388	1803	2679	4757	
08:00 09:00	37	623	749	1409	268	374	173	815	2224	68	769	3	840	410	1078	446	1934	2774	4998	
09:00 10:00	66	575	772	1413	264	313	178	755	2168	99	788	20	907	477	1077	384	1938	2845	5013	
11:30 12:30	47	258	496	801	255	292	189	736	1537	164	859	62	1085	394	942	241	1577	2662	4199	
12:30 13:30	44	262	440	746	252	268	166	686	1432	134	947	55	1136	417	956	250	1623	2759	4191	
15:00 16:00	27	355	545	927	453	730	131	1314	2241	112	1027	60	1199	575	1246	317	2138	3337	5578	
16:00 17:00	27	372	605	1004	449	789	89	1327	2331	117	939	53	1109	609	1179	330	2118	3227	5558	
17:00 18:00	28	371	579	978	379	695	94	1168	2146	127	857	45	1029	601	1208	299	2108	3137	5283	
Sub Total	298	3482	4907	8687	2528	3780	1162	7470	16157	889	6982	310	8181	3899	8685	2655	15239	23420	39577	
U Turns				1				0	1				11				4	15	16	
Total	298	3482	4907	8688	2528	3780	1162	7470	16158	889	6982	310	8192	3899	8685	2655	15243	23435	39593	

EQ 12Hr 414 4840 6821 **12076** 3514 5254 1615 **10383** **22460** 1236 9705 431 **11387** 5420 12072 3690 **21188** **32575** **55034**
 Note: These values are calculated by multiplying the totals by the appropriate expansion factor. **1.39**

AVG 12Hr 414 4840 6821 **12076** 3514 6883 2116 **10383** **22460** 1236 9705 431 **11387** 5420 12072 3690 **21188** **32575** **55034**
 Note: These volumes are calculated by multiplying the Equivalent 12 hr. totals by the AADT factor. **1.00**

AVG 24Hr 542 6340 8936 **15820** 4603 9017 2772 **13602** **29423** 1619 12714 565 **14917** 7100 15814 4834 **27756** **42673** **72095**
 Note: These volumes are calculated by multiplying the Average Daily 12 hr. totals by 12 to 24 expansion factor. **1.31**

Note: U-Turns provided for approach totals. Refer to 'U-Turn' Report for specific breakdown.



Transportation Services - Traffic Services

Turning Movement Count - Study Results

PRINCE OF WALES DR @ WEST HUNT CLUB RD

Survey Date: Monday, February 10, 2020

WO No: 39445

Start Time: 07:00

Device: Miovision

Full Study Cyclist Volume

PRINCE OF WALES DR

WEST HUNT CLUB RD

Time Period	Northbound	Southbound	Street Total	Eastbound	Westbound	Street Total	Grand Total
07:00 07:15	0	0	0	0	0	0	0
07:15 07:30	0	0	0	0	0	0	0
07:30 07:45	0	0	0	0	0	0	0
17:45 18:00	0	0	0	0	0	0	0
07:45 08:00	0	0	0	0	0	0	0
08:00 08:15	0	0	0	0	0	0	0
08:15 08:30	0	0	0	0	0	0	0
08:30 08:45	1	0	1	0	1	1	2
08:45 09:00	1	0	1	0	0	0	1
09:00 09:15	0	1	1	0	0	0	1
09:15 09:30	0	0	0	0	0	0	0
09:30 09:45	0	0	0	0	0	0	0
09:45 10:00	0	1	1	0	0	0	1
11:30 11:45	0	0	0	0	0	0	0
11:45 12:00	0	0	0	0	0	0	0
12:00 12:15	0	0	0	0	0	0	0
12:15 12:30	0	0	0	0	0	0	0
12:30 12:45	0	0	0	0	0	0	0
12:45 13:00	0	0	0	0	0	0	0
13:00 13:15	0	0	0	0	0	0	0
13:15 13:30	0	0	0	0	0	0	0
15:00 15:15	0	0	0	1	0	1	1
15:15 15:30	0	0	0	0	2	2	2
15:30 15:45	0	0	0	0	0	0	0
15:45 16:00	0	0	0	0	0	0	0
16:00 16:15	0	0	0	1	0	1	1
16:15 16:30	0	0	0	0	0	0	0
16:30 16:45	0	0	0	0	0	0	0
16:45 17:00	0	0	0	0	0	0	0
17:00 17:15	0	0	0	0	0	0	0
17:15 17:30	0	1	1	0	0	0	1
17:30 17:45	0	0	0	0	0	0	0
Total	2	3	5	2	3	5	10



Transportation Services - Traffic Services

Turning Movement Count - Study Results

PRINCE OF WALES DR @ WEST HUNT CLUB RD

Survey Date: Monday, February 10, 2020

WO No: 39445

Start Time: 07:00

Device: Miovision

Full Study Pedestrian Volume

PRINCE OF WALES DR

WEST HUNT CLUB RD

Time Period	NB Approach (E or W Crossing)	SB Approach (E or W Crossing)	Total	EB Approach (N or S Crossing)	WB Approach (N or S Crossing)	Total	Grand Total
07:00 07:15	0	0	0	0	0	0	0
07:15 07:30	0	0	0	0	0	0	0
07:30 07:45	0	0	0	0	0	0	0
17:45 18:00	1	0	1	1	0	1	2
07:45 08:00	0	1	1	0	1	1	2
08:00 08:15	0	0	0	0	0	0	0
08:15 08:30	0	0	0	1	0	1	1
08:30 08:45	0	0	0	0	0	0	0
08:45 09:00	0	0	0	0	0	0	0
09:00 09:15	1	0	1	0	0	0	1
09:15 09:30	0	0	0	0	0	0	0
09:30 09:45	0	0	0	0	0	0	0
09:45 10:00	0	0	0	0	0	0	0
11:30 11:45	0	0	0	0	0	0	0
11:45 12:00	0	0	0	0	0	0	0
12:00 12:15	1	0	1	0	0	0	1
12:15 12:30	2	0	2	1	0	1	3
12:30 12:45	1	0	1	0	0	0	1
12:45 13:00	0	0	0	0	0	0	0
13:00 13:15	2	0	2	0	0	0	2
13:15 13:30	1	0	1	0	0	0	1
15:00 15:15	0	0	0	2	0	2	2
15:15 15:30	1	0	1	0	0	0	1
15:30 15:45	2	0	2	0	2	2	4
15:45 16:00	4	0	4	0	2	2	6
16:00 16:15	1	0	1	0	0	0	1
16:15 16:30	4	0	4	1	0	1	5
16:30 16:45	1	0	1	0	0	0	1
16:45 17:00	1	0	1	2	0	2	3
17:00 17:15	1	0	1	0	0	0	1
17:15 17:30	0	0	0	1	0	1	1
17:30 17:45	0	0	0	0	0	0	0
Total	24	1	25	9	5	14	39



Transportation Services - Traffic Services

Turning Movement Count - Study Results

PRINCE OF WALES DR @ WEST HUNT CLUB RD

Survey Date: Monday, February 10, 2020

WO No: 39445

Start Time: 07:00

Device: Miovision

Full Study Heavy Vehicles

PRINCE OF WALES DR

WEST HUNT CLUB RD

Northbound Southbound Eastbound Westbound

Time Period	Northbound			N TOT	Southbound			S TOT	STR TOT	Eastbound			E TOT	Westbound			W TOT	STR TOT	Grand Total
	LT	ST	RT		LT	ST	RT			LT	ST	RT		LT	ST	RT			
07:00 07:15	1	3	2	11	2	3	3	18	29	5	7	1	25	1	8	2	22	47	38
07:15 07:30	0	0	4	14	3	5	1	14	28	3	5	1	20	4	10	2	28	48	38
07:30 07:45	0	4	2	7	2	1	2	12	19	3	13	0	26	0	8	0	25	51	35
17:45 18:00	0	1	0	5	2	2	0	7	12	0	7	0	13	2	6	2	19	32	22
07:45 08:00	1	3	2	10	7	1	2	16	26	2	12	0	23	3	6	1	31	54	40
08:00 08:15	0	2	4	10	1	4	0	11	21	0	8	0	21	0	13	4	30	51	36
08:15 08:30	0	1	5	10	2	2	0	12	22	1	15	0	24	2	8	6	38	62	42
08:30 08:45	1	1	2	13	7	3	2	16	29	1	12	0	28	6	12	2	41	69	49
08:45 09:00	0	1	10	19	2	1	3	12	31	1	15	1	28	6	8	4	45	73	52
09:00 09:15	1	1	4	15	2	6	2	21	36	4	17	0	35	3	11	6	43	78	57
09:15 09:30	0	3	4	14	4	6	5	27	41	2	11	0	29	1	9	7	36	65	53
09:30 09:45	0	1	2	14	4	4	1	18	32	3	13	0	28	7	11	5	42	70	51
09:45 10:00	0	3	3	15	2	4	2	14	29	2	5	0	24	5	15	1	31	55	42
11:30 11:45	1	1	3	17	5	4	2	23	40	4	14	4	36	4	11	7	44	80	60
11:45 12:00	0	2	3	9	2	0	3	13	22	5	14	1	34	3	11	1	34	68	45
12:00 12:15	0	1	0	10	5	4	1	16	26	2	11	1	22	4	7	3	30	52	39
12:15 12:30	1	3	4	17	4	3	3	18	35	2	8	1	22	5	7	3	31	53	44
12:30 12:45	0	3	4	14	2	4	1	12	26	0	10	2	31	1	18	2	37	68	47
12:45 13:00	0	1	2	8	7	3	2	18	26	0	5	0	16	2	9	5	30	46	36
13:00 13:15	1	2	2	13	2	1	2	12	25	1	13	0	33	7	16	4	44	77	51
13:15 13:30	0	2	4	11	1	2	2	16	27	3	14	0	30	3	11	6	39	69	48
15:00 15:15	0	1	1	8	4	4	0	15	23	2	4	1	16	1	9	4	23	39	31
15:15 15:30	0	2	2	9	6	3	2	19	28	0	10	0	29	2	17	6	43	72	50
15:30 15:45	0	2	1	8	6	3	1	13	21	0	2	0	14	2	11	1	23	37	29
15:45 16:00	0	2	2	8	5	2	0	15	23	1	7	1	19	1	10	5	30	49	36
16:00 16:15	0	0	1	8	3	2	1	8	16	1	17	2	32	3	11	1	36	68	42
16:15 16:30	1	1	0	10	0	4	0	8	18	0	10	0	14	4	3	3	20	34	26
16:30 16:45	0	0	1	5	1	1	1	6	11	3	2	0	14	3	8	0	15	29	20
16:45 17:00	1	1	0	6	4	1	1	7	13	0	10	1	19	2	6	0	22	41	27
17:00 17:15	0	2	0	4	0	0	1	7	11	1	5	0	15	2	8	3	18	33	22
17:15 17:30	0	0	2	3	2	0	0	5	8	0	6	0	12	1	6	3	20	32	20
17:30 17:45	0	3	0	4	1	1	0	9	13	0	2	0	7	0	5	4	12	19	16
Total: None	9	53	76	329	100	84	46	438	767	52	304	17	739	90	309	103	982	1721	1,244



Transportation Services - Traffic Services

Turning Movement Count - Study Results

PRINCE OF WALES DR @ WEST HUNT CLUB RD

Survey Date: Monday, February 10, 2020

WO No: 39445

Start Time: 07:00

Device: Miovision

Full Study 15 Minute U-Turn Total

PRINCE OF WALES DR WEST HUNT CLUB RD

Time Period		Northbound U-Turn Total	Southbound U-Turn Total	Eastbound U-Turn Total	Westbound U-Turn Total	Total
07:00	07:15	0	0	1	0	1
07:15	07:30	0	0	0	0	0
07:30	07:45	0	0	0	0	0
17:45	18:00	0	0	0	0	0
07:45	08:00	0	0	0	0	0
08:00	08:15	0	0	0	0	0
08:15	08:30	0	0	1	0	1
08:30	08:45	0	0	0	0	0
08:45	09:00	0	0	1	0	1
09:00	09:15	0	0	0	0	0
09:15	09:30	0	0	2	0	2
09:30	09:45	0	0	0	0	0
09:45	10:00	0	0	0	0	0
11:30	11:45	0	0	0	0	0
11:45	12:00	0	0	1	0	1
12:00	12:15	0	0	1	0	1
12:15	12:30	0	0	1	0	1
12:30	12:45	1	0	0	1	2
12:45	13:00	0	0	1	0	1
13:00	13:15	0	0	1	0	1
13:15	13:30	0	0	0	0	0
15:00	15:15	0	0	0	1	1
15:15	15:30	0	0	0	0	0
15:30	15:45	0	0	0	1	1
15:45	16:00	0	0	0	0	0
16:00	16:15	0	0	0	0	0
16:15	16:30	0	0	0	1	1
16:30	16:45	0	0	0	0	0
16:45	17:00	0	0	1	0	1
17:00	17:15	0	0	0	0	0
17:15	17:30	0	0	0	0	0
17:30	17:45	0	0	0	0	0
Total		1	0	11	4	16

Intersection: Prince of Wales Drive / Esso Commercial Access

Morning Peak Hour Results (July 18, 2023)

hvy factor 1

Time Period		Westbound						Northbound						Eastbound						Southbound						Total		All	Peak Hr Totals		
From	To	RT		TH		LT		RT		TH		LT		RT		TH		LT		RT		TH		LT		Heavy	Passenger	All	Peak Hr Totals		
		Heavy	Passenger	Heavy	Passenger	Heavy	Passenger	Pedestrians	Heavy	Passenger	Heavy	Passenger	Pedestrians	Heavy	Passenger	Heavy	Passenger	Heavy	Passenger	Pedestrians	Heavy	Passenger	Heavy	Passenger	Pedestrians	Heavy	Passenger				
1	7:00	7:15												0	4	0	0	18								0	0	35	35	35	
2	7:15	7:30												0	4	0	0	15									0	0	38	38	73
3	7:30	7:45												0	3	0	0	16									0	0	37	37	110
4	7:45	8:00												0	4	0	0	17									0	0	38	38	148
5	8:00	8:15												0	1	0	0	32									0	0	65	65	178
6	8:15	8:30												0	3	0	0	14									0	0	29	29	169
7	8:30	8:45												0	4	0	0	27									0	0	54	54	186
8	8:45	9:00												0	2	0	0	6									0	1	13	14	162
4	7:45	8:45	<<<Calculated Peak Hour																												
	AM Peak Period	0	0	0	0	0	0	0	0	0	0	0	0	25	0	0	145	0	0	0	0	1	139	0	0	0	0	1	309	310	
	Heavy Vehicle %	#DIV/0!	#DIV/0!	#DIV/0!	#DIV/0!	#DIV/0!	#DIV/0!	0%	0%	0%	0%	0%	0%	12	0	0	90	0	0	0	0	0	84	0	0	0	0	0	0%	186	
	AM Peak Hour	0	0	0	0	0	0	0	0	0	0	0	0	1	10	0	0	90	0	0	0	0	0	84	0	0	0	0	0	186	
	Heavy Vehicle %	#DIV/0!	#DIV/0!	#DIV/0!	#DIV/0!	#DIV/0!	#DIV/0!	0%	0%	0%	0%	0%	0%	12	0	0	90	0	0	0	0	0	84	0	0	0	0	0	0%	186	
	AM Peak Hr Total	0	0	0	0	0	0	0	0	0	0	0	0	1	10	0	0	90	0	0	0	0	0	84	0	0	0	0	0	186	
	Peak Hr Approach T	0	0	0	0	0	0	0	12	0	12	0	0	90	0	0	90	0	0	0	0	84	0	84	0	0	0	0	0	0	

186

Afternoon Peak Hour Results (July 18, 2023)

Time Period		Westbound						Northbound						Eastbound						Southbound						Total		All	Peak Hr Totals			
From	To	RT		TH		LT		RT		TH		LT		RT		TH		LT		RT		TH		LT		Heavy	Passenger	All	Peak Hr Totals			
		Heavy	Passenger	Heavy	Passenger	Heavy	Passenger	Pedestrians	Heavy	Passenger	Heavy	Passenger	Pedestrians	Heavy	Passenger	Heavy	Passenger	Heavy	Passenger	Pedestrians	Heavy	Passenger	Heavy	Passenger	Pedestrians	Heavy	Passenger					
7	3:30	3:45												0	1	0	0	7									0	0	15	15	15	
8	3:45	4:00												0	0	0	0	10									0	0	15	15	30	
9	4:00	4:15												0	3	0	0	6									0	0	16	16	46	
10	4:15	4:30												0	1	0	0	9									0	1	20	21	67	
11	4:30	4:45												0	2	0	1	10									0	1	21	22	74	
12	4:45	5:00												0	0	0	0	5									0	0	11	11	70	
13	5:00	5:15												0	2	0	0	7									0	0	19	19	73	
14	5:15	5:30												0	0	0	0	8									0	0	13	13	65	
15	5:30	5:45												0	0	0	0	7									0	0	14	14	57	
16	5:45	6:00												0	1	0	0	4									0	0	8	8	54	
8	3:45	4:45	<<<Calculated Peak Hour																													
	PM Peak Period	0	0	0	0	0	0	0	0	0	0	0	0	10	0	1	73	0	0	0	0	1	0	1	68	0	0	2	152	154		
	Heavy Vehicle %	#DIV/0!	#DIV/0!	#DIV/0!	#DIV/0!	#DIV/0!	#DIV/0!	0%	0%	0%	0%	0%	0%	6	0	1	35	0	0	0	0	0	1	31	0	0	0	0	0	1%	154	
	PM Peak Hour	0	0	0	0	0	0	0	0	0	0	0	0	1	6	0	0	36	0	0	0	0	0	1	31	0	0	0	0	2	72	74
	Heavy Vehicle %	#DIV/0!	#DIV/0!	#DIV/0!	#DIV/0!	#DIV/0!	#DIV/0!	0%	0%	0%	0%	0%	0%	6	0	1	35	0	0	0	0	0	1	31	0	0	0	0	0	3%	74	
	PM Peak Hr Total	0	0	0	0	0	0	0	0	0	0	0	0	1	6	0	0	36	0	0	0	0	0	1	31	0	0	0	0	2	72	74
	Peak Hr Approach T	0	0	0	0	0	0	0	6	0	6	0	0	36	0	0	36	0	0	0	0	32	0	32	0	0	0	0	0	0	0	

74

Traffic Signal Timing

City of Ottawa, Public Works Department

Traffic Signal Operations Unit

Intersection:	<i>Main:</i> Hunt Club	<i>Side:</i> Prince of Wales
Controller:	ATC 3	TSD: 6377
Author:	Elisabeth Fujiwara	Date: 14-Jul-2023

Existing Timing Plans†

	Plan									Ped Minimum Time		
	AM Peak 1	Off Peak 2	PM Peak 3	Night 4	Weekend 5	Early AM 9	AM Heavy 11	Evening 12	Walk	DW	A+R	
Cycle	140	140	150	100	120	140	150	120				
Offset	68	31	31	X	3	84	68	3				
<i>EB Thru</i>	48	53	63	34	45	50	54	40	7	18	4.6+2.2	
<i>WB Thru</i>	60	66	76	34	45	66	63	40	7	18	4.6+2.2	
<i>NB Left (fp)</i>	20	16	13	15	20	19	22	28	-	-	3.7+2.9	
<i>SB Left (fp)</i>	20	25	28	15	20	19	22	28	-	-	3.7+2.9	
<i>NB Thru</i>	44	31	31	31	35	43	47	31	7	17	3.7+2.9	
<i>SB Thru</i>	44	40	46	31	35	43	47	31	7	17	3.7+2.9	
<i>EB Left (fp)</i>	16	18	15	20	20	12	18	21	-	-	4.6+2.2	
<i>WB Left (fp)</i>	28	31	28	20	20	28	27	21	-	-	4.6+2.2	

Phasing Sequence‡

Plan: 4,5,12

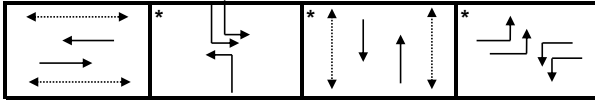

Plan: 2,3

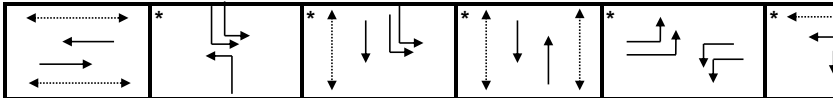

Plan: 1,9,11

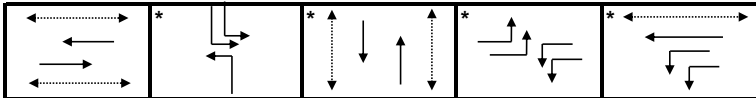

Note: Plan 2 and 3 have a min recall on the NB and SB thru movements.

Schedule

Weekday		Saturday		Sunday	
Time	Plan	Time	Plan	Time	Plan
0:15	4	0:15	4	0:15	4
6:00	9	6:30	5	8:30	12
7:00	1	11:30	2	23:00	4
7:25	11	18:30	12		
9:00	1	23:00	4		
9:30	2				
15:00	3				
18:00	2				
19:00	12				
22:30	4				

Notes

†: Time for each direction includes amber and all red intervals

‡: Start of first phase should be used as reference point for offset

Asterisk (*) Indicates actuated phase

(fp): Fully Protected Left Turn

◄.....► Pedestrian signal

Cost is \$62.38 (\$55.20 + HST)

Traffic Signal Timing

City of Ottawa, Public Works Department

Traffic Signal Operations Unit

Intersection:	<i>Main:</i> Prince of Wales	<i>Side:</i> Deakin
Controller:	ATC 3	TSD: 6378
Author:	Elisabeth Fujiwara	Date: 14-Jul-2023

Existing Timing Plans[†]

	Plan					Ped Minimum Time					
	AM Peak 1	Off Peak 2	PM Peak 3	Night 4	Weekend 5	AM Heavy 1 10	AM Heavy 2 11	Evening 12	Walk	DW	A+R
Cycle	100	90	120	70	120	75	130	80			
Offset	0	90	120	X	40	69	130	80			
NB Thru	67	57	87	37	87	42	90	47	7	16	3.7+2.7
SB Thru	67	57	87	37	87	42	90	47	7	16	3.7+2.7
EB Thru	33	33	33	33	33	33	40	33	7	20	3.3+3.3

Phasing Sequence[‡]

Plan: All

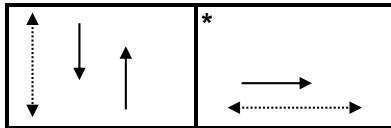

Schedule

Weekday		Saturday		Sunday	
Time	Plan	Time	Plan	Time	Plan
0:15	4	0:15	4	0:15	4
6:00	1	6:30	5	8:30	2
7:25	11	11:30	2	18:00	12
7:45	10	18:30	12	23:00	4
8:25	1	23:00	4		
9:30	2				
15:00	3				
18:00	2				
19:00	12				
22:30	4				

Notes

- †: Time for each direction includes amber and all red intervals
- ‡: Start of first phase should be used as reference point for offset
- Asterisk (*) Indicates actuated phase
- (fp): Fully Protected Left Turn
- ◄.....► Pedestrian signal

Cost is \$62.38 (\$55.20 + HST)



Transportation Services - Traffic Services

Collision Details Report - Public Version

From: January 1, 2017 To: December 31, 2021

Location: DEAKIN ST @ PRINCE OF WALES DR

Traffic Control: Traffic signal

Total Collisions: 26

Date/Day/Time	Environment	Impact Type	Classification	Surface Cond'n	Veh. Dir	Vehicle Manoeuvre	Vehicle type	First Event	No. Ped
2017-Jan-20, Fri,13:07	Clear	Angle	P.D. only	Wet	North	Going ahead	Automobile, station wagon	Other motor vehicle	0
					East	Turning left	Automobile, station wagon	Other motor vehicle	
2017-Jan-27, Fri,09:13	Clear	Angle	P.D. only	Dry	North	Going ahead	Automobile, station wagon	Other motor vehicle	0
					East	Turning left	Automobile, station wagon	Other motor vehicle	
2017-Mar-28, Tue,13:18	Clear	Turning movement	P.D. only	Dry	North	Turning left	Automobile, station wagon	Other motor vehicle	0
					South	Going ahead	Pick-up truck	Other motor vehicle	
2017-May-05, Fri,13:49	Rain	Rear end	P.D. only	Wet	East	Going ahead	Truck - tractor	Other motor vehicle	0
					East	Going ahead	Automobile, station wagon	Other motor vehicle	
2017-May-14, Sun,12:37	Rain	Sideswipe	P.D. only	Wet	South	Going ahead	Automobile, station wagon	Other motor vehicle	0
					South	Stopped	Automobile, station wagon	Other motor vehicle	
					South	Stopped	Pick-up truck	Other motor vehicle	
2017-May-25, Thu,07:06	Rain	Rear end	P.D. only	Wet	South	Slowing or stopping	Automobile, station wagon	Other motor vehicle	0
					South	Stopped	Pick-up truck	Other motor vehicle	
2017-May-26, Fri,08:35	Clear	Sideswipe	P.D. only	Dry	South	Changing lanes	Passenger van	Other motor vehicle	0
					South	Going ahead	Automobile, station wagon	Other motor vehicle	
2017-Sep-05, Tue,16:15	Clear	Sideswipe	P.D. only	Dry	South	Changing lanes	Automobile, station wagon	Other motor vehicle	0
					South	Going ahead	Automobile, station wagon	Other motor vehicle	
2017-Nov-03, Fri,16:59	Clear	Sideswipe	Non-fatal injury	Dry	South	Merging	Automobile, station wagon	Other motor vehicle	0
					South	Going ahead	Pick-up truck	Other motor vehicle	
2017-Nov-13, Mon,17:10	Clear	Rear end	P.D. only	Dry	South	Slowing or stopping	Automobile, station wagon	Other motor vehicle	0
					South	Stopped	Pick-up truck	Other motor vehicle	
2018-Jan-21, Sun,15:24	Clear	Rear end	Non-fatal injury	Dry	South	Going ahead	Automobile, station wagon	Other motor vehicle	0
					South	Stopped	Automobile, station wagon	Other motor vehicle	



Transportation Services - Traffic Services

Collision Details Report - Public Version

From: January 1, 2017 To: December 31, 2021

Location: DEAKIN ST @ PRINCE OF WALES DR

Traffic Control: Traffic signal

Total Collisions: 26

Date/Day/Time	Environment	Impact Type	Classification	Surface Cond'n	Veh. Dir	Vehicle Manoeuvre	Vehicle type	First Event	No. Ped
2018-Feb-15, Thu,15:30	Clear	Rear end	P.D. only	Wet	South	Slowing or stopping	Automobile, station wagon	Other motor vehicle	0
					South	Stopped	Automobile, station wagon	Other motor vehicle	
2018-Mar-14, Wed,12:00	Snow	Sideswipe	P.D. only	Wet	West	Merging	Automobile, station wagon	Other motor vehicle	0
					West	Slowing or stopping	Automobile, station wagon	Other motor vehicle	
2018-Mar-31, Sat,09:39	Clear	Rear end	P.D. only	Dry	South	Going ahead	Automobile, station wagon	Other motor vehicle	0
					South	Stopped	Automobile, station wagon	Other motor vehicle	
2018-Apr-21, Sat,14:57	Clear	Rear end	P.D. only	Dry	South	Going ahead	Automobile, station wagon	Other motor vehicle	0
					South	Stopped	Automobile, station wagon	Other motor vehicle	
2018-Apr-24, Tue,10:01	Clear	Rear end	Non-fatal injury	Dry	South	Going ahead	Automobile, station wagon	Other motor vehicle	0
					South	Slowing or stopping	Automobile, station wagon	Other motor vehicle	
2018-Jun-07, Thu,22:15	Clear	Sideswipe	P.D. only	Dry	South	Going ahead	Automobile, station wagon	Other motor vehicle	0
					South	Going ahead	Automobile, station wagon	Other motor vehicle	
					South	Slowing or stopping	Automobile, station wagon	Other motor vehicle	
2018-Aug-23, Thu,17:47	Clear	Rear end	P.D. only	Dry	North	Going ahead	Pick-up truck	Other motor vehicle	0
					North	Stopped	Passenger van	Other motor vehicle	
					North	Stopped	Automobile, station wagon	Other motor vehicle	
2018-Sep-13, Thu,20:25	Clear	Rear end	Non-fatal injury	Dry	North	Going ahead	Automobile, station wagon	Other motor vehicle	0
					North	Stopped	Police vehicle	Other motor vehicle	
2018-Nov-09, Fri,13:40	Snow	Turning movement	Non-fatal injury	Wet	North	Turning left	Automobile, station wagon	Cyclist	0
					South	Going ahead	Bicycle	Other motor vehicle	
2018-Dec-16, Sun,01:10	Clear	SMV other	Non-fatal injury	Wet	North	Turning left	Automobile, station wagon	Ran off road	0
2019-Aug-21, Wed,16:20	Clear	Rear end	P.D. only	Dry	East	Unknown	Automobile, station wagon	Other motor vehicle	0
					East	Unknown	Pick-up truck	Other motor vehicle	



Transportation Services - Traffic Services

Collision Details Report - Public Version

From: January 1, 2017 To: December 31, 2021

Location: DEAKIN ST @ PRINCE OF WALES DR

Traffic Control: Traffic signal

Total Collisions: 26

Date/Day/Time	Environment	Impact Type	Classification	Surface Cond'n	Veh. Dir	Vehicle Manoeuvre	Vehicle type	First Event	No. Ped
2019-Oct-13, Sun,10:09	Clear	Rear end	P.D. only	Dry	North	Going ahead	Unknown	Other motor vehicle	0
					North	Slowing or stopping	Automobile, station wagon	Other motor vehicle	
2020-Jan-13, Mon,06:36	Snow	Rear end	P.D. only	Wet	North	Slowing or stopping	Automobile, station wagon	Other motor vehicle	0
					North	Stopped	Automobile, station wagon	Other motor vehicle	
2020-Jan-17, Fri,14:30	Clear	Rear end	P.D. only	Wet	South	Slowing or stopping	Pick-up truck	Other motor vehicle	0
					South	Stopped	Pick-up truck	Other motor vehicle	
2021-Dec-04, Sat,10:30	Snow	Rear end	Non-fatal injury	Loose snow	East	Slowing or stopping	Automobile, station wagon	Other motor vehicle	0
					East	Stopped	Pick-up truck	Other motor vehicle	

Location: PRINCE OF WALES DR @ WEST HUNT CLUB RD

Traffic Control: Traffic signal

Total Collisions: 141

Date/Day/Time	Environment	Impact Type	Classification	Surface Cond'n	Veh. Dir	Vehicle Manoeuvre	Vehicle type	First Event	No. Ped
2017-Jan-14, Sat,17:47	Clear	Rear end	P.D. only	Dry	West	Going ahead	Pick-up truck	Other motor vehicle	0
					West	Stopped	Automobile, station wagon	Other motor vehicle	
2017-Jan-21, Sat,16:00	Clear	Rear end	P.D. only	Wet	West	Slowing or stopping	Automobile, station wagon	Other motor vehicle	0
					West	Slowing or stopping	Automobile, station wagon	Other motor vehicle	
2017-Feb-20, Mon,19:33	Clear	Sideswipe	P.D. only	Dry	South	Overtaking	Passenger van	Other motor vehicle	0
					South	Changing lanes	Automobile, station wagon	Other motor vehicle	
2017-Mar-09, Thu,07:46	Clear	Sideswipe	P.D. only	Dry	North	Turning right	Automobile, station wagon	Other motor vehicle	0
					North	Turning right	Automobile, station wagon	Other motor vehicle	
					North	Turning right	Automobile, station wagon	Other motor vehicle	
2017-Mar-09, Thu,12:47	Clear	Rear end	Non-fatal injury	Dry	South	Turning right	Automobile, station wagon	Other motor vehicle	0
					South	Turning right	Automobile, station wagon	Other motor vehicle	



Transportation Services - Traffic Services

Collision Details Report - Public Version

From: January 1, 2017 To: December 31, 2021

Location: PRINCE OF WALES DR @ WEST HUNT CLUB RD

Traffic Control: Traffic signal

Total Collisions: 141

Date/Day/Time	Environment	Impact Type	Classification	Surface Cond'n	Veh. Dir	Vehicle Manoeuvre	Vehicle type	First Event	No. Ped
2017-Mar-14, Tue,18:24	Snow	Rear end	P.D. only	Loose snow	West	Turning left	Automobile, station wagon	Other motor vehicle	0
					West	Turning left	Automobile, station wagon	Other motor vehicle	
2017-Apr-08, Sat,15:55	Rain	Rear end	P.D. only	Wet	North	Going ahead	Automobile, station wagon	Other motor vehicle	0
					North	Stopped	Passenger van	Other motor vehicle	
2017-Apr-11, Tue,22:18	Clear	Angle	P.D. only	Dry	South	Going ahead	Automobile, station wagon	Other motor vehicle	0
					East	Going ahead	Automobile, station wagon	Other motor vehicle	
2017-May-01, Mon,20:31	Rain	Other	P.D. only	Wet	West	Reversing	Unknown	Other motor vehicle	0
					East	Stopped	Passenger van	Other motor vehicle	
2017-May-05, Fri,06:46	Rain	Rear end	Non-fatal injury	Wet	North	Slowing or stopping	Automobile, station wagon	Other motor vehicle	0
					North	Stopped	Pick-up truck	Other motor vehicle	
2017-May-29, Mon,17:30	Clear	Rear end	Non-fatal injury	Dry	East	Slowing or stopping	Pick-up truck	Other motor vehicle	0
					East	Stopped	Automobile, station wagon	Other motor vehicle	
					East	Stopped	Automobile, station wagon	Other motor vehicle	
2017-Jun-06, Tue,17:16	Rain	SMV other	P.D. only	Wet	West	Turning right	Automobile, station wagon	Skidding/sliding	0
2017-Jun-08, Thu,16:13	Clear	Sideswipe	P.D. only	Dry	East	Going ahead	Unknown	Other motor vehicle	0
					East	Merging	Automobile, station wagon	Other motor vehicle	
2017-Jul-07, Fri,16:00	Rain	Sideswipe	P.D. only	Wet	West	Going ahead	Automobile, station wagon	Skidding/sliding	0
					West	Turning left	Automobile, station wagon	Other motor vehicle	
2017-Jul-17, Mon,17:53	Clear	Rear end	P.D. only	Dry	West	Going ahead	Automobile, station wagon	Other motor vehicle	0
					West	Stopped	Automobile, station wagon	Other motor vehicle	
2017-Aug-19, Sat,13:42	Clear	Rear end	Non-fatal injury	Dry	East	Going ahead	Unknown	Other motor vehicle	0
					East	Going ahead	Automobile, station wagon	Other motor vehicle	
2017-Sep-06, Wed,16:55	Clear	Rear end	P.D. only	Dry	South	Unknown	Unknown	Other motor vehicle	0
					South	Stopped	Automobile, station wagon	Other motor vehicle	



Transportation Services - Traffic Services

Collision Details Report - Public Version

From: January 1, 2017 To: December 31, 2021

Location: PRINCE OF WALES DR @ WEST HUNT CLUB RD

Traffic Control: Traffic signal

Total Collisions: 141

Date/Day/Time	Environment	Impact Type	Classification	Surface Cond'n	Veh. Dir	Vehicle Manoeuvre	Vehicle type	First Event	No. Ped
2017-Oct-11, Wed,10:45	Clear	Rear end	P.D. only	Dry	West	Going ahead	Pick-up truck	Other motor vehicle	0
					West	Going ahead	Automobile, station wagon	Other motor vehicle	
2017-Oct-18, Wed,15:05	Clear	Rear end	P.D. only	Dry	West	Turning left	Automobile, station wagon	Other motor vehicle	0
					West	Turning left	Automobile, station wagon	Other motor vehicle	
2017-Oct-21, Sat,17:06	Clear	Rear end	P.D. only	Dry	North	Turning right	Pick-up truck	Other motor vehicle	0
					North	Turning right	Automobile, station wagon	Other motor vehicle	
2017-Oct-24, Tue,10:24	Rain	Sideswipe	P.D. only	Wet	North	Turning left	Automobile, station wagon	Other motor vehicle	0
					North	Turning left	Automobile, station wagon	Other motor vehicle	
2017-Nov-01, Wed,01:34	Clear	Angle	P.D. only	Dry	South	Going ahead	Automobile, station wagon	Other motor vehicle	0
					West	Going ahead	Pick-up truck	Other motor vehicle	
2017-Nov-26, Sun,13:30	Clear	Rear end	P.D. only	Dry	South	Turning right	Automobile, station wagon	Other motor vehicle	0
					South	Turning right	Automobile, station wagon	Other motor vehicle	
					South	Turning right	Automobile, station wagon	Other motor vehicle	
2017-Nov-29, Wed,14:49	Clear	Rear end	P.D. only	Wet	West	Slowing or stopping	Automobile, station wagon	Other motor vehicle	0
					West	Slowing or stopping	Automobile, station wagon	Other motor vehicle	
2017-Dec-06, Wed,08:37	Clear	Rear end	P.D. only	Dry	North	Going ahead	Automobile, station wagon	Other motor vehicle	0
					North	Stopped	Automobile, station wagon	Other motor vehicle	
2017-Dec-14, Thu,16:05	Clear	Sideswipe	P.D. only	Wet	South	Slowing or stopping	Automobile, station wagon	Other motor vehicle	0
					South	Slowing or stopping	Pick-up truck	Other motor vehicle	
2017-Dec-15, Fri,20:35	Snow	Rear end	P.D. only	Loose snow	West	Going ahead	Automobile, station wagon	Skidding/sliding	0
					West	Stopped	Automobile, station wagon	Other motor vehicle	
					West	Stopped	Automobile, station wagon	Other motor vehicle	
2017-Dec-20, Wed,17:38	Clear	Rear end	P.D. only	Dry	West	Changing lanes	Automobile, station wagon	Other motor vehicle	0
					West	Stopped	Automobile, station wagon	Other motor vehicle	



Transportation Services - Traffic Services

Collision Details Report - Public Version

From: January 1, 2017 To: December 31, 2021

Location: PRINCE OF WALES DR @ WEST HUNT CLUB RD

Traffic Control: Traffic signal

Total Collisions: 141

Date/Day/Time	Environment	Impact Type	Classification	Surface Cond'n	Veh. Dir	Vehicle Manoeuver	Vehicle type	First Event	No. Ped
2018-Jan-26, Fri,00:28	Clear	Rear end	Non-fatal injury	Dry	East	Going ahead	Automobile, station wagon	Other motor vehicle	0
					East	Stopped	Automobile, station wagon	Other motor vehicle	
2018-Jan-26, Fri,20:25	Clear	Other	P.D. only	Dry	North	Reversing	Automobile, station wagon	Other motor vehicle	0
					South	Turning left	Automobile, station wagon	Other motor vehicle	
2018-Jan-30, Tue,17:06	Clear	Rear end	P.D. only	Dry	East	Going ahead	Passenger van	Other motor vehicle	0
					East	Slowing or stopping	Automobile, station wagon	Other motor vehicle	
2018-Feb-03, Sat,12:43	Clear	Rear end	P.D. only	Dry	West	Slowing or stopping	Automobile, station wagon	Other motor vehicle	0
					West	Stopped	Automobile, station wagon	Other motor vehicle	
2018-Feb-05, Mon,11:05	Clear	Rear end	P.D. only	Wet	West	Going ahead	Pick-up truck	Other motor vehicle	0
					West	Stopped	Automobile, station wagon	Other motor vehicle	
2018-Feb-08, Thu,13:30	Clear	Sideswipe	P.D. only	Dry	West	Changing lanes	Passenger van	Other motor vehicle	0
					West	Turning left	Passenger van	Other motor vehicle	
2018-Feb-21, Wed,15:50	Clear	Sideswipe	P.D. only	Dry	West	Changing lanes	Automobile, station wagon	Other motor vehicle	0
					West	Going ahead	Automobile, station wagon	Other motor vehicle	
2018-Mar-21, Wed,10:50	Clear	Rear end	Non-fatal injury	Dry	East	Going ahead	Automobile, station wagon	Other motor vehicle	0
					East	Stopped	Automobile, station wagon	Other motor vehicle	
					East	Stopped	Automobile, station wagon	Other motor vehicle	
2018-Mar-26, Mon,15:45	Clear	Rear end	Non-fatal injury	Dry	West	Going ahead	Passenger van	Other motor vehicle	0
					West	Stopped	Pick-up truck	Other motor vehicle	
2018-Apr-16, Mon,06:50	Freezing Rain	Rear end	P.D. only	Ice	West	Turning left	Delivery van	Other motor vehicle	0
					West	Turning left	Pick-up truck	Other motor vehicle	
2018-Apr-26, Thu,07:38	Rain	Rear end	P.D. only	Wet	West	Slowing or stopping	Automobile, station wagon	Other motor vehicle	0
					West	Stopped	Automobile, station wagon	Other motor vehicle	



Transportation Services - Traffic Services

Collision Details Report - Public Version

From: January 1, 2017 To: December 31, 2021

Location: PRINCE OF WALES DR @ WEST HUNT CLUB RD

Traffic Control: Traffic signal

Total Collisions: 141

Date/Day/Time	Environment	Impact Type	Classification	Surface Cond'n	Veh. Dir	Vehicle Manoeuvre	Vehicle type	First Event	No. Ped
2018-May-28, Mon,21:23	Clear	Angle	Non-fatal injury	Dry	North	Going ahead	Automobile, station wagon	Other motor vehicle	0
					West	Turning left	Automobile, station wagon	Other motor vehicle	
2018-May-29, Tue,10:51	Clear	Sideswipe	P.D. only	Dry	West	Changing lanes	Automobile, station wagon	Other motor vehicle	0
					West	Going ahead	Truck and trailer	Other motor vehicle	
2018-Jun-19, Tue,08:30	Clear	Sideswipe	P.D. only	Dry	East	Changing lanes	Passenger van	Other motor vehicle	0
					East	Going ahead	Automobile, station wagon	Other motor vehicle	
2018-Jun-21, Thu,12:51	Clear	Sideswipe	P.D. only	Dry	East	Changing lanes	Automobile, station wagon	Other motor vehicle	0
					East	Going ahead	Automobile, station wagon	Other motor vehicle	
					East	Stopped	Automobile, station wagon	Other motor vehicle	
2018-Jul-23, Mon,09:13	Clear	Rear end	P.D. only	Dry	North	Turning right	Automobile, station wagon	Other motor vehicle	0
					North	Turning right	Automobile, station wagon	Other motor vehicle	
2018-Jul-27, Fri,16:40	Clear	Rear end	P.D. only	Dry	South	Going ahead	Pick-up truck	Other motor vehicle	0
					South	Stopped	Automobile, station wagon	Other motor vehicle	
2018-Aug-09, Thu,17:55	Clear	Rear end	Non-fatal injury	Dry	North	Slowing or stopping	Pick-up truck	Other motor vehicle	0
					North	Stopped	Automobile, station wagon	Other motor vehicle	
					North	Stopped	Automobile, station wagon	Other motor vehicle	
2018-Sep-17, Mon,15:47	Clear	Rear end	Non-fatal injury	Dry	East	Slowing or stopping	Automobile, station wagon	Other motor vehicle	0
					East	Stopped	Automobile, station wagon	Other motor vehicle	
					East	Stopped	Automobile, station wagon	Other motor vehicle	
2018-Sep-23, Sun,12:50	Clear	Rear end	P.D. only	Dry	South	Turning right	Automobile, station wagon	Other motor vehicle	0
					South	Turning right	Automobile, station wagon	Other motor vehicle	
2018-Oct-01, Mon,17:43	Rain	Rear end	P.D. only	Wet	East	Going ahead	Automobile, station wagon	Other motor vehicle	0
					East	Stopped	Automobile, station wagon	Other motor vehicle	



Transportation Services - Traffic Services

Collision Details Report - Public Version

From: January 1, 2017 To: December 31, 2021

Location: PRINCE OF WALES DR @ WEST HUNT CLUB RD

Traffic Control: Traffic signal

Total Collisions: 141

Date/Day/Time	Environment	Impact Type	Classification	Surface Cond'n	Veh. Dir	Vehicle Manoeuvre	Vehicle type	First Event	No. Ped
2018-Oct-17, Wed,19:00	Clear	Sideswipe	P.D. only	Dry	West	Changing lanes	Automobile, station wagon	Other motor vehicle	0
					West	Turning left	Automobile, station wagon	Other motor vehicle	
2018-Oct-24, Wed,14:06	Clear	Rear end	P.D. only	Dry	North	Turning right	School bus	Other motor vehicle	0
					North	Turning right	Automobile, station wagon	Other motor vehicle	
2018-Oct-26, Fri,13:42	Clear	Rear end	P.D. only	Dry	South	Turning left	Pick-up truck	Other motor vehicle	0
					South	Turning left	Automobile, station wagon	Other motor vehicle	
2018-Oct-29, Mon,11:15	Rain	Rear end	P.D. only	Wet	South	Slowing or stopping	Truck - tractor	Other motor vehicle	0
					South	Stopped	Automobile, station wagon	Other motor vehicle	
2018-Nov-20, Tue,10:30	Snow	Rear end	P.D. only	Slush	South	Turning left	Pick-up truck	Other motor vehicle	0
					South	Turning left	Automobile, station wagon	Other motor vehicle	
2018-Dec-12, Wed,17:50	Clear	Rear end	P.D. only	Wet	South	Turning left	Automobile, station wagon	Other motor vehicle	0
					South	Turning left	Automobile, station wagon	Other motor vehicle	
					South	Turning left	Automobile, station wagon	Other motor vehicle	
2018-Dec-20, Thu,12:49	Clear	Angle	P.D. only	Dry	South	Turning right	Automobile, station wagon	Other motor vehicle	0
					West	Going ahead	Automobile, station wagon	Other motor vehicle	
2018-Dec-29, Sat,13:00	Clear	Rear end	P.D. only	Dry	North	Turning right	Pick-up truck	Other motor vehicle	0
					North	Turning right	Automobile, station wagon	Other motor vehicle	
2019-Jan-03, Thu,14:51	Clear	Rear end	P.D. only	Wet	North	Turning right	Pick-up truck	Other motor vehicle	0
					North	Turning right	Automobile, station wagon	Other motor vehicle	
2019-Jan-27, Sun,12:09	Drifting Snow	Rear end	P.D. only	Ice	South	Turning left	Automobile, station wagon	Other motor vehicle	0
					South	Turning left	Automobile, station wagon	Other motor vehicle	
2019-Jan-28, Mon,15:04	Clear	Rear end	Non-fatal injury	Dry	South	Turning left	Passenger van	Other motor vehicle	0
					South	Turning left	Construction equipment	Other motor vehicle	



Transportation Services - Traffic Services

Collision Details Report - Public Version

From: January 1, 2017 To: December 31, 2021

Location: PRINCE OF WALES DR @ WEST HUNT CLUB RD

Traffic Control: Traffic signal

Total Collisions: 141

Date/Day/Time	Environment	Impact Type	Classification	Surface Cond'n	Veh. Dir	Vehicle Manoeuvre	Vehicle type	First Event	No. Ped
2019-Feb-07, Thu,23:45	Freezing Rain	Sideswipe	P.D. only	Wet	East	Going ahead	Truck - dump	Other motor vehicle	0
					East	Going ahead	Automobile, station wagon	Other motor vehicle	
2019-Mar-03, Sun,12:30	Clear	Rear end	P.D. only	Dry	North	Turning right	Unknown	Other motor vehicle	0
					North	Turning right	Automobile, station wagon	Other motor vehicle	
2019-Mar-13, Wed,08:45	Clear	Rear end	Non-fatal injury	Dry	West	Turning right	Automobile, station wagon	Other motor vehicle	0
					West	Turning right	Automobile, station wagon	Other motor vehicle	
2019-Apr-02, Tue,14:28	Clear	Rear end	P.D. only	Dry	East	Turning left	Automobile, station wagon	Other motor vehicle	0
					East	Turning left	Automobile, station wagon	Other motor vehicle	
2019-May-02, Thu,18:15	Clear	Rear end	P.D. only	Dry	East	Slowing or stopping	Automobile, station wagon	Other motor vehicle	0
					East	Stopped	Automobile, station wagon	Other motor vehicle	
					East	Stopped	Automobile, station wagon	Other motor vehicle	
2019-Jun-07, Fri,16:20	Clear	Rear end	P.D. only	Dry	North	Unknown	Unknown	Other motor vehicle	0
					North	Stopped	Automobile, station wagon	Other motor vehicle	
2019-Jun-13, Thu,16:56	Rain	Sideswipe	P.D. only	Wet	East	Changing lanes	Automobile, station wagon	Other motor vehicle	0
					East	Going ahead	Automobile, station wagon	Other motor vehicle	
2019-Jul-12, Fri,15:42	Clear	Rear end	Non-fatal injury	Dry	East	Turning left	Automobile, station wagon	Other motor vehicle	0
					East	Turning left	Passenger van	Other motor vehicle	
2019-Jul-30, Tue,17:34	Clear	Sideswipe	P.D. only	Dry	East	Changing lanes	Pick-up truck	Other motor vehicle	0
					East	Turning left	Automobile, station wagon	Other motor vehicle	
2019-Aug-12, Mon,22:17	Rain	Angle	P.D. only	Wet	South	Going ahead	Unknown	Other motor vehicle	0
					West	Going ahead	Automobile, station wagon	Other motor vehicle	
2019-Aug-15, Thu,15:20	Clear	Rear end	P.D. only	Dry	West	Going ahead	Automobile, station wagon	Other motor vehicle	0
					West	Stopped	Automobile, station wagon	Other motor vehicle	



Transportation Services - Traffic Services

Collision Details Report - Public Version

From: January 1, 2017 To: December 31, 2021

Location: PRINCE OF WALES DR @ WEST HUNT CLUB RD

Traffic Control: Traffic signal

Total Collisions: 141

Date/Day/Time	Environment	Impact Type	Classification	Surface Cond'n	Veh. Dir	Vehicle Manoeuvre	Vehicle type	First Event	No. Ped
2019-Aug-19, Mon,16:50	Clear	Rear end	P.D. only	Dry	South	Going ahead	Automobile, station wagon	Other motor vehicle	0
					South	Stopped	Automobile, station wagon	Other motor vehicle	
2019-Aug-25, Sun,14:12	Clear	Rear end	Non-fatal injury	Dry	West	Turning left	Automobile, station wagon	Other motor vehicle	0
					West	Turning left	Automobile, station wagon	Other motor vehicle	
2019-Sep-04, Wed,08:10	Clear	Rear end	Non-fatal injury	Dry	West	Going ahead	Automobile, station wagon	Other motor vehicle	0
					West	Slowing or stopping	Automobile, station wagon	Other motor vehicle	
					West	Stopped	Pick-up truck	Other motor vehicle	
2019-Sep-25, Wed,09:15	Clear	Sideswipe	P.D. only	Dry	South	Turning left	Automobile, station wagon	Other motor vehicle	0
					South	Turning left	Automobile, station wagon	Other motor vehicle	
2019-Oct-07, Mon,08:26	Clear	Angle	Non-fatal injury	Dry	North	Turning right	Pick-up truck	Cyclist	0
					West	Going ahead	Bicycle	Other motor vehicle	
2019-Oct-22, Tue,16:10	Rain	Sideswipe	P.D. only	Wet	South	Changing lanes	Automobile, station wagon	Other motor vehicle	0
					South	Turning left	Truck - dump	Other motor vehicle	
2019-Nov-06, Wed,08:00	Clear	Sideswipe	P.D. only	Dry	East	Changing lanes	Automobile, station wagon	Other motor vehicle	0
					East	Going ahead	Pick-up truck	Other motor vehicle	
2019-Nov-12, Tue,07:17	Clear	Approaching	P.D. only	Loose snow	East	Going ahead	Automobile, station wagon	Other motor vehicle	0
					West	Going ahead	Automobile, station wagon	Other motor vehicle	
2019-Nov-21, Thu,17:49	Rain	Angle	P.D. only	Wet	North	Turning right	Truck - open	Other motor vehicle	0
					East	Going ahead	Truck - open	Other motor vehicle	
2019-Nov-24, Sun,13:45	Clear	Rear end	P.D. only	Dry	East	Going ahead	Unknown	Other motor vehicle	0
					East	Stopped	Automobile, station wagon	Other motor vehicle	
2019-Dec-13, Fri,15:25	Clear	Sideswipe	P.D. only	Dry	West	Changing lanes	Automobile, station wagon	Other motor vehicle	0
					West	Slowing or stopping	Automobile, station wagon	Other motor vehicle	



Transportation Services - Traffic Services

Collision Details Report - Public Version

From: January 1, 2017 To: December 31, 2021

Location: PRINCE OF WALES DR @ WEST HUNT CLUB RD

Traffic Control: Traffic signal

Total Collisions: 141

Date/Day/Time	Environment	Impact Type	Classification	Surface Cond'n	Veh. Dir	Vehicle Manoeuver	Vehicle type	First Event	No. Ped
2019-Dec-14, Sat,17:01	Rain	Turning movement	P.D. only	Wet	East	Turning left	Automobile, station wagon	Other motor vehicle	0
					West	Going ahead	Automobile, station wagon	Other motor vehicle	
2019-Dec-26, Thu,21:55	Freezing Rain	Rear end	P.D. only	Ice	North	Going ahead	Automobile, station wagon	Other motor vehicle	0
					North	Stopped	Automobile, station wagon	Other motor vehicle	
2019-Dec-30, Mon,14:39	Freezing Rain	Rear end	P.D. only	Slush	West	Going ahead	Automobile, station wagon	Other motor vehicle	0
					West	Stopped	Automobile, station wagon	Other motor vehicle	
					West	Stopped	Automobile, station wagon	Other motor vehicle	
2020-Jan-02, Thu,16:08	Clear	Rear end	P.D. only	Dry	East	Going ahead	Automobile, station wagon	Other motor vehicle	0
					East	Stopped	Automobile, station wagon	Other motor vehicle	
2020-Jan-06, Mon,15:05	Snow	Rear end	P.D. only	Slush	South	Turning right	Automobile, station wagon	Other motor vehicle	0
					South	Turning right	Automobile, station wagon	Other motor vehicle	
2020-Jan-08, Wed,09:16	Clear	Rear end	Non-fatal injury	Dry	South	Turning right	Automobile, station wagon	Other motor vehicle	0
					South	Turning right	Automobile, station wagon	Other motor vehicle	
2020-Jan-23, Thu,16:10	Clear	Rear end	P.D. only	Wet	West	Going ahead	Automobile, station wagon	Other motor vehicle	0
					West	Going ahead	Unknown	Other motor vehicle	
2020-Jan-29, Wed,11:36	Clear	Rear end	P.D. only	Dry	North	Turning right	Automobile, station wagon	Other motor vehicle	0
					North	Turning right	Automobile, station wagon	Other motor vehicle	
2020-Feb-01, Sat,10:08	Snow	Rear end	P.D. only	Wet	South	Turning right	Automobile, station wagon	Other motor vehicle	0
					South	Turning right	Pick-up truck	Other motor vehicle	
2020-Feb-01, Sat,20:36	Snow	Rear end	P.D. only	Wet	North	Turning right	Automobile, station wagon	Other motor vehicle	0
					North	Turning right	Automobile, station wagon	Other motor vehicle	
2020-Feb-07, Fri,15:25	Snow	Sideswipe	P.D. only	Loose snow	South	Changing lanes	Automobile, station wagon	Skidding/sliding	0
					South	Turning right	Pick-up truck	Other motor vehicle	



Transportation Services - Traffic Services

Collision Details Report - Public Version

From: January 1, 2017 To: December 31, 2021

Location: PRINCE OF WALES DR @ WEST HUNT CLUB RD

Traffic Control: Traffic signal

Total Collisions: 141

Date/Day/Time	Environment	Impact Type	Classification	Surface Cond'n	Veh. Dir	Vehicle Manoeuver	Vehicle type	First Event	No. Ped
2020-Feb-07, Fri,20:51	Snow	Angle	P.D. only	Loose snow	West	Going ahead	Pick-up truck	Other motor vehicle	0
					South	Going ahead	Automobile, station wagon	Other motor vehicle	
2020-Feb-24, Mon,00:22	Clear	Angle	P.D. only	Dry	South	Going ahead	Automobile, station wagon	Other motor vehicle	0
					West	Going ahead	Automobile, station wagon	Other motor vehicle	
2020-Feb-25, Tue,15:05	Clear	Rear end	P.D. only	Wet	East	Turning right	Automobile, station wagon	Other motor vehicle	0
					East	Turning right	Passenger van	Other motor vehicle	
2020-Feb-29, Sat,08:33	Clear	Angle	Non-fatal injury	Dry	East	Going ahead	Automobile, station wagon	Other motor vehicle	0
					North	Going ahead	Automobile, station wagon	Other motor vehicle	
2020-Mar-12, Thu,08:00	Clear	Rear end	Non-fatal injury	Dry	North	Turning right	Automobile, station wagon	Other motor vehicle	0
					North	Turning right	Automobile, station wagon	Other motor vehicle	
2020-Apr-21, Tue,15:31	Clear	Rear end	P.D. only	Dry	East	Turning right	Automobile, station wagon	Other motor vehicle	0
					East	Turning right	Pick-up truck	Other motor vehicle	
2020-Apr-27, Mon,21:20	Clear	Rear end	P.D. only	Dry	North	Going ahead	Automobile, station wagon	Other motor vehicle	0
					North	Stopped	Automobile, station wagon	Other motor vehicle	
2020-May-20, Wed,10:30	Clear	Rear end	P.D. only	Dry	East	Unknown	Unknown	Other motor vehicle	0
					East	Stopped	Pick-up truck	Other motor vehicle	
2020-May-22, Fri,17:00	Clear	Sideswipe	P.D. only	Dry	North	Changing lanes	Automobile, station wagon	Other motor vehicle	0
					North	Turning left	Automobile, station wagon	Other motor vehicle	
2020-Jun-01, Mon,18:49	Clear	Sideswipe	P.D. only	Dry	North	Overtaking	Unknown	Other motor vehicle	0
					North	Turning right	Automobile, station wagon	Other motor vehicle	
2020-Jul-15, Wed,14:55	Clear	Rear end	P.D. only	Dry	North	Unknown	Unknown	Other motor vehicle	0
					North	Stopped	Automobile, station wagon	Other motor vehicle	
2020-Aug-03, Mon,13:13	Clear	Rear end	P.D. only	Dry	South	Turning right	Pick-up truck	Other motor vehicle	0
					South	Turning right	Automobile, station wagon	Other motor vehicle	



Transportation Services - Traffic Services

Collision Details Report - Public Version

From: January 1, 2017 To: December 31, 2021

Location: PRINCE OF WALES DR @ WEST HUNT CLUB RD

Traffic Control: Traffic signal

Total Collisions: 141

Date/Day/Time	Environment	Impact Type	Classification	Surface Cond'n	Veh. Dir	Vehicle Manoeuvre	Vehicle type	First Event	No. Ped
2020-Aug-05, Wed,12:30	Clear	Sideswipe	P.D. only	Dry	West	Turning left	Automobile, station wagon	Other motor vehicle	0
					West	Turning left	Automobile, station wagon	Other motor vehicle	
2020-Sep-15, Tue,15:10	Clear	Rear end	P.D. only	Dry	West	Going ahead	Automobile, station wagon	Other motor vehicle	0
					West	Unknown	Unknown	Other motor vehicle	
2020-Sep-17, Thu,22:32	Clear	SMV other	P.D. only	Dry	South	Turning left	Motorcycle	Skidding/sliding	0
2020-Sep-27, Sun,18:36	Clear	Rear end	P.D. only	Dry	East	Turning right	Pick-up truck	Other motor vehicle	0
					East	Turning right	Automobile, station wagon	Other motor vehicle	
2020-Oct-02, Fri,22:17	Clear	Rear end	Non-fatal injury	Dry	West	Turning left	Pick-up truck	Other motor vehicle	0
					West	Turning left	Automobile, station wagon	Other motor vehicle	
					West	Turning left	Automobile, station wagon	Other motor vehicle	
					West	Turning left	Automobile, station wagon	Other motor vehicle	
2020-Oct-19, Mon,07:45	Rain	Sideswipe	P.D. only	Wet	South	Changing lanes	Automobile, station wagon	Other motor vehicle	0
					South	Turning left	Automobile, station wagon	Other motor vehicle	
2020-Nov-30, Mon,09:03	Clear	Sideswipe	P.D. only	Dry	North	Changing lanes	Automobile, station wagon	Other motor vehicle	0
					North	Going ahead	Truck and trailer	Other motor vehicle	
2020-Dec-01, Tue,05:38	Rain	Angle	P.D. only	Wet	East	Going ahead	Automobile, station wagon	Other motor vehicle	0
					South	Going ahead	Automobile, station wagon	Other motor vehicle	
2020-Dec-10, Thu,13:39	Clear	Rear end	P.D. only	Dry	North	Turning right	Passenger van	Other motor vehicle	0
					North	Turning right	Pick-up truck	Other motor vehicle	
2020-Dec-11, Fri,17:39	Clear	SMV other	P.D. only	Dry	North	Going ahead	Automobile, station wagon	Curb	0
2020-Dec-22, Tue,09:30	Clear	Angle	P.D. only	Wet	North	Turning right	Pick-up truck	Other motor vehicle	0
					East	Going ahead	Passenger van	Other motor vehicle	
2020-Dec-27, Sun,15:04	Clear	Angle	Non-fatal injury	Dry	South	Going ahead	Automobile, station wagon	Other motor vehicle	0
					East	Going ahead	Automobile, station wagon	Other motor vehicle	



Transportation Services - Traffic Services

Collision Details Report - Public Version

From: January 1, 2017 To: December 31, 2021

Location: PRINCE OF WALES DR @ WEST HUNT CLUB RD

Traffic Control: Traffic signal

Total Collisions: 141

Date/Day/Time	Environment	Impact Type	Classification	Surface Cond'n	Veh. Dir	Vehicle Manoeuvre	Vehicle type	First Event	No. Ped
2021-Feb-04, Thu,15:30	Clear	Rear end	P.D. only	Dry	East	Turning right	Unknown	Other motor vehicle	0
					East	Turning right	Automobile, station wagon	Other motor vehicle	
2021-Feb-27, Sat,12:20	Snow	Rear end	P.D. only	Loose snow	North	Turning right	Automobile, station wagon	Other motor vehicle	0
					North	Turning right	Pick-up truck	Other motor vehicle	
2021-Feb-27, Sat,15:52	Clear	Sideswipe	Non-fatal injury	Wet	East	Changing lanes	Snow plow	Other motor vehicle	0
					East	Going ahead	Automobile, station wagon	Other motor vehicle	
2021-Feb-28, Sun,15:30	Clear	Sideswipe	P.D. only	Dry	West	Changing lanes	Unknown	Other motor vehicle	0
					West	Turning left	Automobile, station wagon	Other motor vehicle	
2021-May-30, Sun,18:18	Clear	Rear end	Non-fatal injury	Dry	East	Turning right	Pick-up truck	Other motor vehicle	0
					East	Turning right	Automobile, station wagon	Other motor vehicle	
2021-May-31, Mon,14:53	Clear	Rear end	P.D. only	Dry	North	Unknown	Unknown	Other motor vehicle	0
					North	Slowing or stopping	Automobile, station wagon	Other motor vehicle	
2021-Jun-23, Wed,18:58	Clear	Rear end	P.D. only	Dry	North	Turning right	Passenger van	Other motor vehicle	0
					North	Turning right	Automobile, station wagon	Other motor vehicle	
2021-Aug-08, Sun,18:48	Clear	Rear end	P.D. only	Dry	West	Changing lanes	Automobile, station wagon	Other motor vehicle	0
					West	Turning right	Pick-up truck	Other motor vehicle	
2021-Aug-12, Thu,14:15	Clear	Rear end	P.D. only	Dry	South	Slowing or stopping	Automobile, station wagon	Other motor vehicle	0
					South	Slowing or stopping	Pick-up truck	Other motor vehicle	
2021-Aug-13, Fri,09:00	Clear	Rear end	P.D. only	Dry	West	Going ahead	Automobile, station wagon	Other motor vehicle	0
					West	Stopped	Pick-up truck	Other motor vehicle	
2021-Aug-28, Sat,10:50	Clear	Turning movement	P.D. only	Dry	East	Turning right	Pick-up truck	Other motor vehicle	0
					East	Turning right	Pick-up truck	Other motor vehicle	
2021-Sep-12, Sun,11:00	Clear	Rear end	Non-fatal injury	Dry	East	Turning right	Automobile, station wagon	Other motor vehicle	0
					East	Turning right	Pick-up truck	Other motor vehicle	



Transportation Services - Traffic Services

Collision Details Report - Public Version

From: January 1, 2017 To: December 31, 2021

Location: PRINCE OF WALES DR @ WEST HUNT CLUB RD

Traffic Control: Traffic signal

Total Collisions: 141

Date/Day/Time	Environment	Impact Type	Classification	Surface Cond'n	Veh. Dir	Vehicle Manoeuver	Vehicle type	First Event	No. Ped
2021-Sep-28, Tue,08:20	Clear	Rear end	P.D. only	Dry	North	Changing lanes	Pick-up truck	Other motor vehicle	0
					North	Going ahead	Automobile, station wagon	Other motor vehicle	
2021-Nov-01, Mon,15:19	Clear	Rear end	P.D. only	Dry	South	Going ahead	Automobile, station wagon	Other motor vehicle	0
					South	Stopped	Automobile, station wagon	Other motor vehicle	
2021-Nov-04, Thu,00:00	Clear	Rear end	P.D. only	Dry	South	Turning right	Unknown	Other motor vehicle	0
					South	Turning right	Automobile, station wagon	Other motor vehicle	
2021-Nov-08, Mon,14:35	Clear	Rear end	P.D. only	Dry	East	Turning left	Automobile, station wagon	Other motor vehicle	0
					East	Turning left	Automobile, station wagon	Other motor vehicle	
2021-Nov-10, Wed,17:00	Clear	Rear end	P.D. only	Dry	North	Turning right	Unknown	Other motor vehicle	0
					North	Turning right	Pick-up truck	Other motor vehicle	
2021-Nov-12, Fri,16:45	Clear	Sideswipe	P.D. only	Dry	West	Turning left	Automobile, station wagon	Other motor vehicle	0
					West	Turning left	Pick-up truck	Other motor vehicle	
2021-Nov-12, Fri,17:30	Clear	Rear end	P.D. only	Dry	South	Unknown	Unknown	Other motor vehicle	0
					South	Stopped	Automobile, station wagon	Other motor vehicle	
					South	Stopped	Unknown	Other motor vehicle	
2021-Nov-24, Wed,17:19	Clear	Sideswipe	P.D. only	Dry	North	Changing lanes	Automobile, station wagon	Other motor vehicle	0
					North	Stopped	Automobile, station wagon	Other motor vehicle	
2021-Dec-12, Sun,14:32	Clear	Rear end	P.D. only	Wet	North	Turning right	Automobile, station wagon	Other motor vehicle	0
					North	Turning right	Automobile, station wagon	Other motor vehicle	
2021-Dec-16, Thu,11:18	Clear	Rear end	P.D. only	Wet	West	Slowing or stopping	Pick-up truck	Other motor vehicle	0
					West	Stopped	Automobile, station wagon	Other motor vehicle	
2021-Dec-23, Thu,17:05	Clear	Rear end	Non-fatal injury	Wet	East	Going ahead	Pick-up truck	Other motor vehicle	0
					East	Slowing or stopping	Automobile, station wagon	Other motor vehicle	



Transportation Services - Traffic Services

Collision Details Report - Public Version

From: January 1, 2017 To: December 31, 2021

Location: PRINCE OF WALES DR @ WEST HUNT CLUB RD

Traffic Control: Traffic signal

Total Collisions: 141

Date/Day/Time	Environment	Impact Type	Classification	Surface Cond'n	Veh. Dir	Vehicle Manoeuver	Vehicle type	First Event	No. Ped
2021-Dec-29, Wed,08:01	Clear	Rear end	P.D. only	Wet	North	Turning right	Automobile, station wagon	Other motor vehicle	0
					North	Turning right	Automobile, station wagon	Other motor vehicle	

Location: PRINCE OF WALES DR btwn DEAKIN ST & WATERBEND LANE

Traffic Control: No control

Total Collisions: 1

Date/Day/Time	Environment	Impact Type	Classification	Surface Cond'n	Veh. Dir	Vehicle Manoeuver	Vehicle type	First Event	No. Ped
2017-Jan-25, Wed,16:38	Clear	Rear end	P.D. only	Dry	North	Going ahead	Automobile, station wagon	Other motor vehicle	0
					North	Stopped	Automobile, station wagon	Other motor vehicle	
					North	Slowing or stopping	Automobile, station wagon	Other motor vehicle	

Location: PRINCE OF WALES DR btwn TURN LANE & WATERBEND LANE

Traffic Control: No control

Total Collisions: 18

Date/Day/Time	Environment	Impact Type	Classification	Surface Cond'n	Veh. Dir	Vehicle Manoeuver	Vehicle type	First Event	No. Ped
2017-Jan-02, Mon,21:29	Clear	Turning movement	P.D. only	Wet	South	Making "U" turn	Pick-up truck	Other motor vehicle	0
					South	Going ahead	Pick-up truck	Other motor vehicle	
2017-Jun-07, Wed,13:49	Clear	Turning movement	P.D. only	Dry	South	Making "U" turn	Automobile, station wagon	Other motor vehicle	0
					South	Overtaking	Automobile, station wagon	Other motor vehicle	
2017-Jul-02, Sun,17:02	Rain	Rear end	P.D. only	Wet	South	Slowing or stopping	Automobile, station wagon	Skidding/sliding	0
					South	Stopped	Pick-up truck	Other motor vehicle	
2017-Sep-08, Fri,18:49	Clear	Rear end	P.D. only	Dry	South	Slowing or stopping	Automobile, station wagon	Other motor vehicle	0
					South	Slowing or stopping	Automobile, station wagon	Other motor vehicle	
					South	Slowing or stopping	Automobile, station wagon	Other motor vehicle	
2017-Nov-22, Wed,16:39	Clear	Turning movement	P.D. only	Dry	North	Turning left	Passenger van	Other motor vehicle	0
					South	Turning right	Automobile, station wagon	Other motor vehicle	



Transportation Services - Traffic Services

Collision Details Report - Public Version

From: January 1, 2017 To: December 31, 2021

Location: PRINCE OF WALES DR btwn TURN LANE & WATERBEND LANE

Traffic Control: No control

Total Collisions: 18

Date/Day/Time	Environment	Impact Type	Classification	Surface Cond'n	Veh. Dir	Vehicle Manoeuvre	Vehicle type	First Event	No. Ped
2017-Dec-07, Thu,07:08	Snow	Turning movement	P.D. only	Ice	North	Turning left	School bus	Other motor vehicle	0
					South	Going ahead	Automobile, station wagon	Other motor vehicle	
2018-Sep-11, Tue,13:30	Clear	Rear end	P.D. only	Dry	South	Going ahead	Unknown	Other motor vehicle	0
					South	Turning right	Automobile, station wagon	Other motor vehicle	
2018-Oct-23, Tue,16:41	Clear	Rear end	P.D. only	Dry	South	Going ahead	Automobile, station wagon	Other motor vehicle	0
					South	Going ahead	Automobile, station wagon	Other motor vehicle	
					South	Going ahead	Automobile, station wagon	Other motor vehicle	
2018-Nov-15, Thu,11:12	Clear	Angle	P.D. only	Dry	East	Changing lanes	Automobile, station wagon	Other motor vehicle	0
					South	Going ahead	Automobile, station wagon	Other motor vehicle	
2019-Feb-15, Fri,08:00	Snow	Rear end	Non-fatal injury	Wet	North	Slowing or stopping	Automobile, station wagon	Other motor vehicle	0
					North	Going ahead	Automobile, station wagon	Other motor vehicle	
2019-Jun-03, Mon,15:34	Clear	Turning movement	Non-fatal injury	Dry	South	Making "U" turn	Pick-up truck	Other motor vehicle	0
					South	Going ahead	Automobile, station wagon	Other motor vehicle	
2019-Jun-10, Mon,16:47	Clear	Turning movement	P.D. only	Dry	South	Going ahead	Automobile, station wagon	Other motor vehicle	0
					North	Turning left	Automobile, station wagon	Other motor vehicle	
2019-Jul-17, Wed,11:03	Clear	Turning movement	P.D. only	Dry	South	Turning right	Truck and trailer	Other motor vehicle	0
					South	Going ahead	Automobile, station wagon	Other motor vehicle	
2019-Jul-26, Fri,15:45	Clear	Sideswipe	P.D. only	Dry	South	Changing lanes	Automobile, station wagon	Other motor vehicle	0
					South	Going ahead	Automobile, station wagon	Other motor vehicle	
2019-Jul-30, Tue,16:40	Clear	Sideswipe	P.D. only	Dry	South	Changing lanes	Automobile, station wagon	Other motor vehicle	0
					South	Going ahead	Automobile, station wagon	Other motor vehicle	
2020-Feb-24, Mon,15:52	Clear	Rear end	P.D. only	Dry	South	Unknown	Unknown	Other motor vehicle	0
					South	Slowing or stopping	Automobile, station wagon	Other motor vehicle	



Transportation Services - Traffic Services

Collision Details Report - Public Version

From: January 1, 2017 To: December 31, 2021

Location: PRINCE OF WALES DR btwn TURN LANE & WATERBEND LANE

Traffic Control: No control

Total Collisions: 18

Date/Day/Time	Environment	Impact Type	Classification	Surface Cond'n	Veh. Dir	Vehicle Manoeuver	Vehicle type	First Event	No. Ped
2020-Jul-08, Wed,17:36	Clear	Turning movement	P.D. only	Dry	South	Making "U" turn	Passenger van	Other motor vehicle	0
					South	Going ahead	Pick-up truck	Other motor vehicle	
2021-Nov-29, Mon,12:16	Clear	Sideswipe	P.D. only	Dry	South	Changing lanes	Pick-up truck	Other motor vehicle	0
					South	Going ahead	Automobile, station wagon	Other motor vehicle	

Location: PRINCE OF WALES DR btwn TURN LANE & WEST HUNT CLUB RD

Traffic Control: No control

Total Collisions: 1

Date/Day/Time	Environment	Impact Type	Classification	Surface Cond'n	Veh. Dir	Vehicle Manoeuver	Vehicle type	First Event	No. Ped
2021-Sep-30, Thu,13:07	Clear	Angle	P.D. only	Dry	East	Turning left	Automobile, station wagon	Other motor vehicle	0
					South	Going ahead	Automobile, station wagon	Other motor vehicle	

APPENDIX “C”

SYNCHRO ANALYSIS OUTPUT SHEETS EXISTING (2023)

Lanes, Volumes, Timings

2175 Prince of Wales - existing AM (reg) - 1.0 PHF

3: Prince of Wales Drive & West Hunt Club Road/Hunt Club Road

09/07/2023

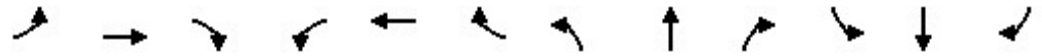

Lane Group	EBL	EBT	EBR	WBL	WBT	WBR	NBL	NBT	NBR	SBL	SBT	SBR
Lane Configurations	↖↖	↗↗	↖	↖↖	↗↗	↖	↖	↗↗	↖	↖↖	↗↗	↖
Traffic Volume (vph)	86	834	9	527	1095	446	66	725	923	281	411	208
Future Volume (vph)	86	834	9	527	1095	446	66	725	923	281	411	208
Ideal Flow (vphpl)	1800	1800	1800	1800	1800	1800	1800	1800	1800	1800	1800	1800
Lane Width (m)	3.7	3.5	4.8	3.7	3.5	3.7	3.7	3.5	4.8	3.7	3.5	3.5
Storage Length (m)	125.0		150.0	150.0		100.0	50.0		0.0	125.0		200.0
Storage Lanes	2		1	2		1	1		1	2		1
Taper Length (m)	7.6			7.6			7.6			7.6		
Lane Util. Factor	0.97	0.95	1.00	0.97	0.95	1.00	1.00	0.95	1.00	0.97	0.95	1.00
Ped Bike Factor	1.00		0.98	1.00		0.98	1.00		0.98	1.00		0.98
Fr _t			0.850			0.850			0.850			0.850
Fl _t Protected	0.950			0.950			0.950			0.950		
Satd. Flow (prot)	3022	3161	1535	3225	3252	1488	1662	3349	1683	3195	3221	1427
Fl _t Permitted	0.950			0.950			0.950			0.950		
Satd. Flow (perm)	3020	3161	1511	3222	3252	1465	1659	3349	1658	3188	3221	1405
Right Turn on Red			Yes			Yes			Yes			Yes
Satd. Flow (RTOR)			182			274			248			208
Link Speed (k/h)		80			80			60				60
Link Distance (m)		187.8			279.7			97.7				205.8
Travel Time (s)		8.5			12.6			5.9				12.3
Confl. Peds. (#/hr)	2		2	2		2	2		2	2		2
Peak Hour Factor	1.00	1.00	1.00	1.00	1.00	1.00	1.00	1.00	1.00	1.00	1.00	1.00
Heavy Vehicles (%)	11%	7%	13%	4%	4%	4%	4%	1%	3%	5%	5%	6%
Adj. Flow (vph)	86	834	9	527	1095	446	66	725	923	281	411	208
Shared Lane Traffic (%)												
Lane Group Flow (vph)	86	834	9	527	1095	446	66	725	923	281	411	208
Turn Type	Prot	NA	Perm	Prot	NA	Perm	Prot	NA	Perm	Prot	NA	Perm
Protected Phases	5	2		1	6		7	4		3	8	
Permitted Phases			2			6			4			8
Detector Phase	5	2	2	1	6	6	7	4	4	3	8	8
Switch Phase												
Minimum Initial (s)	1.0	1.0	1.0	1.0	1.0	1.0	1.0	1.0	1.0	1.0	1.0	1.0
Minimum Split (s)	11.6	31.8	31.8	11.6	34.2	34.2	11.6	31.6	31.6	11.6	31.6	31.6
Total Split (s)	16.0	48.0	48.0	28.0	60.0	60.0	20.0	44.0	44.0	20.0	44.0	44.0
Total Split (%)	11.4%	34.3%	34.3%	20.0%	42.9%	42.9%	14.3%	31.4%	31.4%	14.3%	31.4%	31.4%
Maximum Green (s)	9.4	41.2	41.2	21.4	53.2	53.2	13.4	37.4	37.4	13.4	37.4	37.4
Yellow Time (s)	3.7	4.6	4.6	3.7	4.6	4.6	3.7	3.7	3.7	3.7	3.7	3.7
All-Red Time (s)	2.9	2.2	2.2	2.9	2.2	2.2	2.9	2.9	2.9	2.9	2.9	2.9
Lost Time Adjust (s)	0.0	0.0	0.0	0.0	0.0	0.0	0.0	0.0	0.0	0.0	0.0	0.0
Total Lost Time (s)	6.6	6.8	6.8	6.6	6.8	6.8	6.6	6.6	6.6	6.6	6.6	6.6
Lead/Lag	Lead	Lag	Lag	Lead	Lag	Lag	Lead	Lag	Lag	Lead	Lag	Lag
Lead-Lag Optimize?	Yes	Yes	Yes	Yes	Yes	Yes	Yes	Yes	Yes	Yes	Yes	Yes
Vehicle Extension (s)	3.0	3.0	3.0	3.0	3.0	3.0	3.0	3.0	3.0	3.0	3.0	3.0
Recall Mode	None	C-Max	C-Max	None	C-Max	C-Max	None	Max	Max	None	Max	Max
Walk Time (s)		7.0	7.0		7.0	7.0		7.0	7.0		7.0	7.0
Flash Dont Walk (s)		18.0	18.0		18.0	18.0		17.0	17.0		17.0	17.0
Pedestrian Calls (#/hr)		2	2		2	2		2	2		2	2
Act Effct Green (s)	8.6	41.2	41.2	21.4	54.0	54.0	10.5	37.4	37.4	13.4	42.9	42.9
Actuated g/C Ratio	0.06	0.29	0.29	0.15	0.39	0.39	0.08	0.27	0.27	0.10	0.31	0.31



Lane Group	EBL	EBT	EBR	WBL	WBT	WBR	NBL	NBT	NBR	SBL	SBT	SBR
v/c Ratio	0.46	0.90	0.02	1.07	0.87	0.61	0.53	0.81	1.48	0.92	0.42	0.36
Control Delay	71.6	60.7	0.0	115.9	49.0	16.5	77.0	56.3	251.4	97.2	41.6	6.9
Queue Delay	0.0	0.0	0.0	0.0	0.0	0.0	0.0	0.0	0.0	0.0	0.0	0.0
Total Delay	71.6	60.7	0.0	115.9	49.0	16.5	77.0	56.3	251.4	97.2	41.6	6.9
LOS	E	E	A	F	D	B	E	E	F	F	D	A
Approach Delay		61.1			59.0			162.2			50.9	
Approach LOS		E			E			F			D	
Queue Length 50th (m)	11.0	107.6	0.0	~76.4	136.5	34.3	16.5	91.5	~275.9	37.2	45.3	0.0
Queue Length 95th (m)	19.2	#140.0	0.0	#108.9	164.4	67.6	30.6	113.5	#348.4	#61.6	61.6	17.6
Internal Link Dist (m)		163.8			255.7			73.7			181.8	
Turn Bay Length (m)	125.0		150.0	150.0		100.0	50.0			125.0		200.0
Base Capacity (vph)	202	930	573	492	1254	733	159	894	624	305	986	574
Starvation Cap Reductn	0	0	0	0	0	0	0	0	0	0	0	0
Spillback Cap Reductn	0	0	0	0	0	0	0	0	0	0	0	0
Storage Cap Reductn	0	0	0	0	0	0	0	0	0	0	0	0
Reduced v/c Ratio	0.43	0.90	0.02	1.07	0.87	0.61	0.42	0.81	1.48	0.92	0.42	0.36

Intersection Summary

Area Type: Other
 Cycle Length: 140
 Actuated Cycle Length: 140
 Offset: 68 (49%), Referenced to phase 2:EBT and 6:WBT, Start of Green
 Natural Cycle: 150
 Control Type: Actuated-Coordinated
 Maximum v/c Ratio: 1.48
 Intersection Signal Delay: 89.6
 Intersection Capacity Utilization 110.0%
 Analysis Period (min) 15
 Intersection LOS: F
 ICU Level of Service H

~ Volume exceeds capacity, queue is theoretically infinite.
 Queue shown is maximum after two cycles.

95th percentile volume exceeds capacity, queue may be longer.
 Queue shown is maximum after two cycles.

Splits and Phases: 3: Prince of Wales Drive & West Hunt Club Road/Hunt Club Road

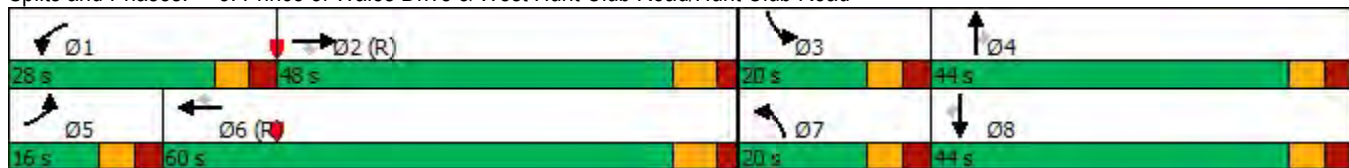

Lanes, Volumes, Timings
7: Prince of Wales Drive & Deakin Street

2175 Prince of Wales - existing AM (reg) - 1.0 PHF

09/07/2023



Lane Group	EBL	EBR	NBL	NBT	SBT	SBR
Lane Configurations						
Traffic Volume (vph)	502	22	156	1226	554	397
Future Volume (vph)	502	22	156	1226	554	397
Ideal Flow (vphpl)	1800	1800	1800	1800	1800	1800
Storage Length (m)	70.0	0.0	100.0			0.0
Storage Lanes	1	0	1			0
Taper Length (m)	7.6		7.6			
Lane Util. Factor	0.97	0.95	1.00	0.95	0.95	0.95
Ped Bike Factor	1.00		1.00		0.99	
Frt	0.994				0.937	
Flt Protected	0.954		0.950			
Satd. Flow (prot)	3279	0	1695	3390	3144	0
Flt Permitted	0.954		0.270			
Satd. Flow (perm)	3272	0	481	3390	3144	0
Right Turn on Red		Yes				Yes
Satd. Flow (RTOR)	4				325	
Link Speed (k/h)	50			60	60	
Link Distance (m)	195.1			117.9	111.9	
Travel Time (s)	14.0			7.1	6.7	
Confl. Peds. (#/hr)	2	2	2			2
Peak Hour Factor	1.00	1.00	1.00	1.00	1.00	1.00
Adj. Flow (vph)	502	22	156	1226	554	397
Shared Lane Traffic (%)						
Lane Group Flow (vph)	524	0	156	1226	951	0
Turn Type	Prot		Perm	NA	NA	
Protected Phases	4			2	6	
Permitted Phases			2			
Detector Phase	4		2	2	6	
Switch Phase						
Minimum Initial (s)	1.0		5.0	5.0	5.0	
Minimum Split (s)	33.6		29.4	29.4	29.4	
Total Split (s)	33.6		67.0	67.0	67.0	
Total Split (%)	33.4%		66.6%	66.6%	66.6%	
Maximum Green (s)	27.0		60.6	60.6	60.6	
Yellow Time (s)	3.3		3.7	3.7	3.7	
All-Red Time (s)	3.3		2.7	2.7	2.7	
Lost Time Adjust (s)	0.0		0.0	0.0	0.0	
Total Lost Time (s)	6.6		6.4	6.4	6.4	
Lead/Lag						
Lead-Lag Optimize?						
Vehicle Extension (s)	3.0		3.0	3.0	3.0	
Recall Mode	None		C-Max	C-Max	C-Max	
Walk Time (s)	7.0		7.0	7.0	7.0	
Flash Dont Walk (s)	20.0		16.0	16.0	16.0	
Pedestrian Calls (#/hr)	2		2	2	2	
Act Effct Green (s)	21.3		66.3	66.3	66.3	
Actuated g/C Ratio	0.21		0.66	0.66	0.66	
v/c Ratio	0.75		0.49	0.55	0.44	
Control Delay	43.8		16.6	10.9	6.1	

Lanes, Volumes, Timings
7: Prince of Wales Drive & Deakin Street

2175 Prince of Wales - existing AM (reg) - 1.0 PHF

09/07/2023



Lane Group	EBL	EBR	NBL	NBT	SBT	SBR
Queue Delay	0.0		0.0	0.0	0.0	
Total Delay	43.8		16.6	10.9	6.1	
LOS	D		B	B	A	
Approach Delay	43.8			11.5	6.1	
Approach LOS	D			B	A	
Queue Length 50th (m)	45.5		12.7	55.4	23.1	
Queue Length 95th (m)	57.1		34.8	84.5	40.5	
Internal Link Dist (m)	171.1			93.9	87.9	
Turn Bay Length (m)	70.0		100.0			
Base Capacity (vph)	882		316	2234	2183	
Starvation Cap Reductn	0		0	0	0	
Spillback Cap Reductn	0		0	0	0	
Storage Cap Reductn	0		0	0	0	
Reduced v/c Ratio	0.59		0.49	0.55	0.44	

Intersection Summary

Area Type:	Other
Cycle Length:	100.6
Actuated Cycle Length:	100.6
Offset:	0 (0%), Referenced to phase 2:NBTL and 6:SBT, Start of Green
Natural Cycle:	75
Control Type:	Actuated-Coordinated
Maximum v/c Ratio:	0.75
Intersection Signal Delay:	15.7
Intersection LOS:	B
Intersection Capacity Utilization	71.3%
ICU Level of Service	C
Analysis Period (min)	15

Splits and Phases: 7: Prince of Wales Drive & Deakin Street

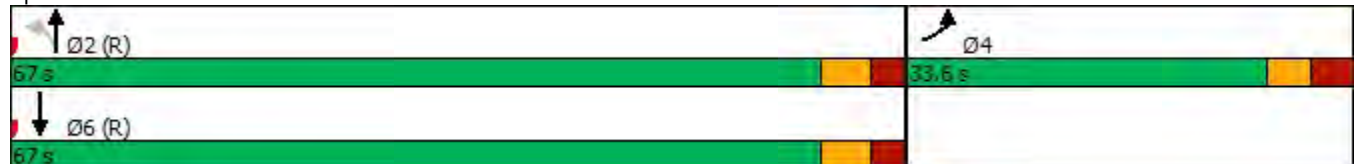

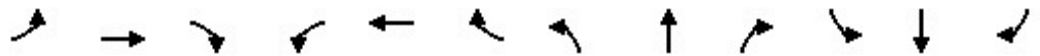

Lane Group	EBL	EBT	EBR	WBL	WBT	WBR	NBL	NBT	NBR	SBL	SBT	SBR
Lane Configurations												
Traffic Volume (vph)	102	1071	56	609	1230	351	29	450	743	447	799	116
Future Volume (vph)	102	1071	56	609	1230	351	29	450	743	447	799	116
Ideal Flow (vphpl)	1800	1800	1800	1800	1800	1800	1800	1800	1800	1800	1800	1800
Lane Width (m)	3.7	3.5	4.8	3.7	3.5	3.7	3.7	3.5	4.8	3.7	3.5	3.5
Storage Length (m)	125.0		150.0	150.0		100.0	50.0		0.0	125.0		200.0
Storage Lanes	2		1	2		1	1		1	2		1
Taper Length (m)	7.6			7.6			7.6			7.6		
Lane Util. Factor	0.97	0.95	1.00	0.97	0.95	1.00	1.00	0.95	1.00	0.97	0.95	1.00
Ped Bike Factor	1.00		0.99	1.00		0.99	1.00		0.99	1.00		0.99
Fr _t			0.850			0.850			0.850			0.850
Fl _t Protected	0.950			0.950			0.950			0.950		
Satd. Flow (prot)	3288	3283	1651	3321	3252	1488	1729	3316	1717	3195	3349	1455
Fl _t Permitted	0.950			0.950			0.950			0.950		
Satd. Flow (perm)	3287	3283	1627	3319	3252	1466	1727	3316	1691	3186	3349	1433
Right Turn on Red			Yes			Yes			Yes			Yes
Satd. Flow (RTOR)			277			351			307			216
Link Speed (k/h)		80			80			60				60
Link Distance (m)		187.8			279.7			97.7				205.8
Travel Time (s)		8.5			12.6			5.9				12.3
Confl. Peds. (#/hr)	2		2	2		2	2		2	2		2
Peak Hour Factor	1.00	1.00	1.00	1.00	1.00	1.00	1.00	1.00	1.00	1.00	1.00	1.00
Heavy Vehicles (%)	2%	3%	5%	1%	4%	4%	0%	2%	1%	5%	1%	4%
Adj. Flow (vph)	102	1071	56	609	1230	351	29	450	743	447	799	116
Shared Lane Traffic (%)												
Lane Group Flow (vph)	102	1071	56	609	1230	351	29	450	743	447	799	116
Turn Type	Prot	NA	Perm	Prot	NA	Perm	Prot	NA	Perm	Prot	NA	Perm
Protected Phases	5	2		1	6		7	4		3	8	
Permitted Phases			2			6			4			8
Detector Phase	5	2	2	1	6	6	7	4	4	3	8	8
Switch Phase												
Minimum Initial (s)	5.0	5.0	5.0	5.0	5.0	5.0	5.0	5.0	5.0	5.0	5.0	5.0
Minimum Split (s)	11.6	30.6	30.6	11.6	31.6	31.6	11.6	30.6	30.6	11.6	31.6	31.6
Total Split (s)	13.0	31.0	31.0	28.0	46.0	46.0	13.0	31.0	31.0	28.0	46.0	46.0
Total Split (%)	11.0%	26.3%	26.3%	23.7%	39.0%	39.0%	11.0%	26.3%	26.3%	23.7%	39.0%	39.0%
Maximum Green (s)	6.4	24.4	24.4	21.4	39.4	39.4	6.4	24.4	24.4	21.4	39.4	39.4
Yellow Time (s)	3.7	3.7	3.7	3.7	3.7	3.7	3.7	3.7	3.7	3.7	3.7	3.7
All-Red Time (s)	2.9	2.9	2.9	2.9	2.9	2.9	2.9	2.9	2.9	2.9	2.9	2.9
Lost Time Adjust (s)	0.0	0.0	0.0	0.0	0.0	0.0	0.0	0.0	0.0	0.0	0.0	0.0
Total Lost Time (s)	6.6	6.6	6.6	6.6	6.6	6.6	6.6	6.6	6.6	6.6	6.6	6.6
Lead/Lag	Lead	Lag	Lag	Lead	Lag	Lag	Lead	Lag	Lag	Lead	Lag	Lag
Lead-Lag Optimize?	Yes	Yes	Yes	Yes	Yes	Yes	Yes	Yes	Yes	Yes	Yes	Yes
Vehicle Extension (s)	3.0	3.0	3.0	3.0	3.0	3.0	3.0	3.0	3.0	3.0	3.0	3.0
Recall Mode	None	C-Max	C-Max	None	C-Max	C-Max	None	Max	Max	None	Max	Max
Walk Time (s)		7.0	7.0		7.0	7.0		7.0	7.0		7.0	7.0
Flash Dont Walk (s)		17.0	17.0		18.0	18.0		17.0	17.0		18.0	18.0
Pedestrian Calls (#/hr)		2	2		2	2		2	2		2	2
Act Effct Green (s)	6.4	24.4	24.4	21.4	39.4	39.4	6.2	25.8	25.8	20.0	44.6	44.6
Actuated g/C Ratio	0.05	0.21	0.21	0.18	0.33	0.33	0.05	0.22	0.22	0.17	0.38	0.38



Lane Group	EBL	EBT	EBR	WBL	WBT	WBR	NBL	NBT	NBR	SBL	SBT	SBR
v/c Ratio	0.57	1.58	0.10	1.01	1.13	0.49	0.32	0.62	1.22	0.82	0.63	0.17
Control Delay	67.6	300.6	0.4	87.7	108.8	5.4	63.5	46.5	137.7	60.8	33.9	0.6
Queue Delay	0.0	0.0	0.0	0.0	0.0	0.0	0.0	0.0	0.0	0.0	0.0	0.0
Total Delay	67.6	300.6	0.4	87.7	108.8	5.4	63.5	46.5	137.7	60.8	33.9	0.6
LOS	E	F	A	F	F	A	E	D	F	E	C	A
Approach Delay	267.5						86.4		102.3		39.9	
Approach LOS	F						F		F		D	
Queue Length 50th (m)	11.1	~170.7	0.0	~68.6	~160.4	0.0	6.1	46.6	~143.3	47.2	78.0	0.0
Queue Length 95th (m)	19.5	#208.1	0.0	#102.6	#198.6	18.5	15.0	62.8	#210.5	63.7	98.6	0.0
Internal Link Dist (m)	163.8						255.7		73.7		181.8	
Turn Bay Length (m)	125.0		150.0		150.0		100.0		50.0		200.0	
Base Capacity (vph)	178	678	556	602	1085	723	93	724	609	579	1266	676
Starvation Cap Reductn	0	0	0	0	0	0	0	0	0	0	0	0
Spillback Cap Reductn	0	0	0	0	0	0	0	0	0	0	0	0
Storage Cap Reductn	0	0	0	0	0	0	0	0	0	0	0	0
Reduced v/c Ratio	0.57	1.58	0.10	1.01	1.13	0.49	0.31	0.62	1.22	0.77	0.63	0.17

Intersection Summary

Area Type: Other
 Cycle Length: 118
 Actuated Cycle Length: 118
 Offset: 31 (26%), Referenced to phase 2:EBT and 6:WBT, Start of Green
 Natural Cycle: 150
 Control Type: Actuated-Coordinated
 Maximum v/c Ratio: 1.58
 Intersection Signal Delay: 116.2 Intersection LOS: F
 Intersection Capacity Utilization 110.0% ICU Level of Service H
 Analysis Period (min) 15
 ~ Volume exceeds capacity, queue is theoretically infinite.
 Queue shown is maximum after two cycles.
 # 95th percentile volume exceeds capacity, queue may be longer.
 Queue shown is maximum after two cycles.

Splits and Phases: 3: Prince of Wales Drive & West Hunt Club Road/Hunt Club Road

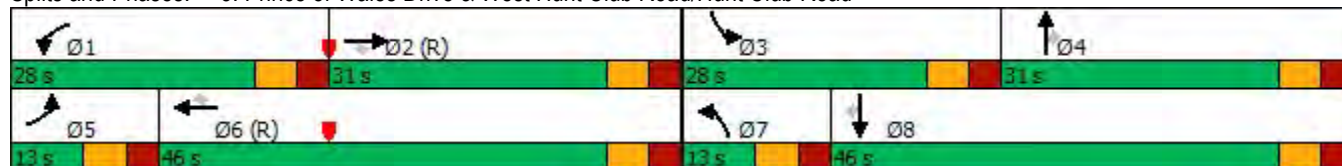

Lanes, Volumes, Timings
7: Prince of Wales Drive & Deakin Street

2175 Prince of Wales - existing PM - 1.0 PHF
09/07/2023



Lane Group	EBL	EBR	NBL	NBT	SBT	SBR
Lane Configurations						
Traffic Volume (vph)	460	185	34	767	1298	170
Future Volume (vph)	460	185	34	767	1298	170
Ideal Flow (vphpl)	1800	1800	1800	1800	1800	1800
Storage Length (m)	70.0	0.0	100.0			0.0
Storage Lanes	1	0	1			0
Taper Length (m)	7.6		7.6			
Lane Util. Factor	0.97	0.95	1.00	0.95	0.95	0.95
Ped Bike Factor	0.95				0.99	
Fr _t	0.957				0.983	
Fl _t Protected	0.966		0.950			
Satd. Flow (prot)	3122	0	1729	3390	3317	0
Fl _t Permitted	0.966		0.129			
Satd. Flow (perm)	3033	0	235	3390	3317	0
Right Turn on Red		Yes				Yes
Satd. Flow (RTOR)	48				26	
Link Speed (k/h)	50			60	60	
Link Distance (m)	195.1			117.9	111.9	
Travel Time (s)	14.0			7.1	6.7	
Confl. Peds. (#/hr)	20	20	20			20
Peak Hour Factor	1.00	1.00	1.00	1.00	1.00	1.00
Heavy Vehicles (%)	2%	2%	0%	2%	1%	5%
Adj. Flow (vph)	460	185	34	767	1298	170
Shared Lane Traffic (%)						
Lane Group Flow (vph)	645	0	34	767	1468	0
Turn Type	Prot		Perm	NA	NA	
Protected Phases	4			2	6	
Permitted Phases			2			
Detector Phase	4		2	2	6	
Switch Phase						
Minimum Initial (s)	5.0		5.0	5.0	5.0	
Minimum Split (s)	24.6		24.4	24.4	24.4	
Total Split (s)	33.0		87.0	87.0	87.0	
Total Split (%)	27.5%		72.5%	72.5%	72.5%	
Maximum Green (s)	26.4		80.6	80.6	80.6	
Yellow Time (s)	3.3		3.7	3.7	3.7	
All-Red Time (s)	3.3		2.7	2.7	2.7	
Lost Time Adjust (s)	0.0		0.0	0.0	0.0	
Total Lost Time (s)	6.6		6.4	6.4	6.4	
Lead/Lag						
Lead-Lag Optimize?						
Vehicle Extension (s)	3.0		3.0	3.0	3.0	
Recall Mode	None		C-Max	C-Max	C-Max	
Walk Time (s)	7.0		7.0	7.0	7.0	
Flash Dont Walk (s)	11.0		11.0	11.0	11.0	
Pedestrian Calls (#/hr)	0		0	0	0	
Act Effct Green (s)	25.7		81.3	81.3	81.3	
Actuated g/C Ratio	0.21		0.68	0.68	0.68	
v/c Ratio	0.91		0.21	0.33	0.65	



Lane Group	EBL	EBR	NBL	NBT	SBT	SBR
Control Delay	61.3		11.6	8.6	12.7	
Queue Delay	0.0		0.0	0.0	0.0	
Total Delay	61.3		11.6	8.6	12.7	
LOS	E		B	A	B	
Approach Delay	61.3			8.8	12.7	
Approach LOS	E			A	B	
Queue Length 50th (m)	65.6		2.6	33.9	88.2	
Queue Length 95th (m)	#94.5		7.6	42.8	107.9	
Internal Link Dist (m)	171.1			93.9	87.9	
Turn Bay Length (m)	70.0		100.0			
Base Capacity (vph)	724		159	2297	2256	
Starvation Cap Reductn	0		0	0	0	
Spillback Cap Reductn	0		0	0	0	
Storage Cap Reductn	0		0	0	0	
Reduced v/c Ratio	0.89		0.21	0.33	0.65	

Intersection Summary

Area Type: Other
 Cycle Length: 120
 Actuated Cycle Length: 120
 Offset: 0 (0%), Referenced to phase 2:NBT and 6:SBT, Start of Green
 Natural Cycle: 60
 Control Type: Actuated-Coordinated
 Maximum v/c Ratio: 0.91
 Intersection Signal Delay: 22.4
 Intersection LOS: C
 Intersection Capacity Utilization 75.2%
 ICU Level of Service D
 Analysis Period (min) 15
 # 95th percentile volume exceeds capacity, queue may be longer.
 Queue shown is maximum after two cycles.

Splits and Phases: 7: Prince of Wales Drive & Deakin Street

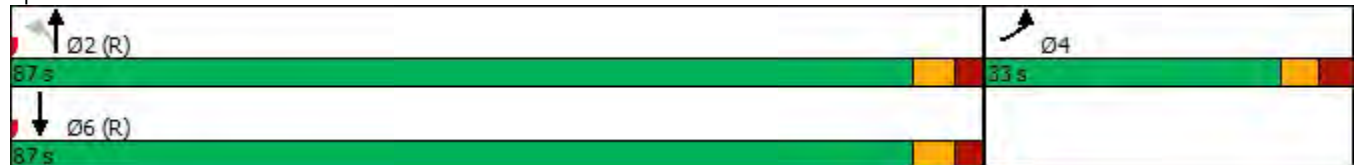

Intersection						
Int Delay, s/veh	0.6					
Movement	EBL	EBR	NBL	NBT	SBT	SBR
Lane Configurations		↗	↘	↑↑↑	↑↑↑	
Traffic Vol, veh/h	0	90	15	1782	899	84
Future Vol, veh/h	0	90	15	1782	899	84
Conflicting Peds, #/hr	20	20	20	0	0	20
Sign Control	Stop	Stop	Free	Free	Free	Free
RT Channelized	-	None	-	None	-	None
Storage Length	-	0	50	-	-	-
Veh in Median Storage, #	0	-	-	0	0	-
Grade, %	0	-	-	0	0	-
Peak Hour Factor	90	90	90	90	90	90
Heavy Vehicles, %	2	2	2	2	2	2
Mvmt Flow	0	100	17	1980	999	93

Major/Minor	Minor2	Major1	Major2		
Conflicting Flow All	-	586	1112	0	-
Stage 1	-	-	-	-	-
Stage 2	-	-	-	-	-
Critical Hdwy	-	7.14	5.34	-	-
Critical Hdwy Stg 1	-	-	-	-	-
Critical Hdwy Stg 2	-	-	-	-	-
Follow-up Hdwy	-	3.92	3.12	-	-
Pot Cap-1 Maneuver	0	389	345	-	-
Stage 1	0	-	-	-	-
Stage 2	0	-	-	-	-
Platoon blocked, %				-	-
Mov Cap-1 Maneuver	-	371	336	-	-
Mov Cap-2 Maneuver	-	-	-	-	-
Stage 1	-	-	-	-	-
Stage 2	-	-	-	-	-

Approach	EB	NB	SB
HCM Control Delay, s	18.2	0.1	0
HCM LOS	C		

Minor Lane/Major Mvmt	NBL	NBT	EBLn1	SBT	SBR
Capacity (veh/h)	336	-	371	-	-
HCM Lane V/C Ratio	0.05	-	0.27	-	-
HCM Control Delay (s)	16.3	-	18.2	-	-
HCM Lane LOS	C	-	C	-	-
HCM 95th %tile Q(veh)	0.2	-	1.1	-	-

Intersection						
Int Delay, s/veh	0.3					
Movement	EBL	EBR	NBL	NBT	SBT	SBR
Lane Configurations		↗	↘	↑↑↑	↑↑↑	
Traffic Vol, veh/h	0	36	6	1270	1490	32
Future Vol, veh/h	0	36	6	1270	1490	32
Conflicting Peds, #/hr	20	20	20	0	0	20
Sign Control	Stop	Stop	Free	Free	Free	Free
RT Channelized	-	None	-	None	-	None
Storage Length	-	0	50	-	-	-
Veh in Median Storage, #	0	-	-	0	0	-
Grade, %	0	-	-	0	0	-
Peak Hour Factor	90	90	90	90	90	90
Heavy Vehicles, %	2	2	2	2	2	2
Mvmt Flow	0	40	7	1411	1656	36

Major/Minor	Minor2	Major1	Major2		
Conflicting Flow All	-	886	1712	0	-
Stage 1	-	-	-	-	-
Stage 2	-	-	-	-	-
Critical Hdwy	-	7.14	5.34	-	-
Critical Hdwy Stg 1	-	-	-	-	-
Critical Hdwy Stg 2	-	-	-	-	-
Follow-up Hdwy	-	3.92	3.12	-	-
Pot Cap-1 Maneuver	0	247	175	-	-
Stage 1	0	-	-	-	-
Stage 2	0	-	-	-	-
Platoon blocked, %				-	-
Mov Cap-1 Maneuver	-	236	170	-	-
Mov Cap-2 Maneuver	-	-	-	-	-
Stage 1	-	-	-	-	-
Stage 2	-	-	-	-	-

Approach	EB	NB	SB
HCM Control Delay, s	23.3	0.1	0
HCM LOS	C		

Minor Lane/Major Mvmt	NBL	NBT	EBLn1	SBT	SBR
Capacity (veh/h)	170	-	236	-	-
HCM Lane V/C Ratio	0.039	-	0.169	-	-
HCM Control Delay (s)	27	-	23.3	-	-
HCM Lane LOS	D	-	C	-	-
HCM 95th %tile Q(veh)	0.1	-	0.6	-	-

APPENDIX “D”

PROPOSED ACCESS CONCEPT

CITY OF OTTAWA
PRINCE OF WALES - MYERS SITE

PROPOSED ROADWAY MODIFICATIONS TO
ACCOMMODATE MYERS SITE



PROJECT REF. NUMBER: 7327

Contract No. 7327 Dwg. No. 01

Sheet 1 of 1

Asset Group

Des. AP Chk'd. AEG

Dwn. AP Chk'd. AEG

Utility Circ. No. Index No.

Cost. Inspector

Scale:

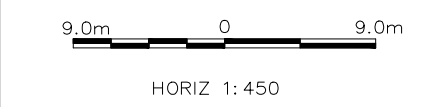

NOTE: The location of utilities is approximate only, the exact location should be determined by consulting the municipal authorities and utility companies concerned. The contractor shall prove the location of utilities and shall be responsible for adequate protection from damage.

No.	Description	By	Date (dd/mm/yy)
1	AS SUBMITTED TO CITY FOR COMMENT	AP	15/12/23
2	AS SUBMITTED TO CITY FOR COMMENT	AP	11/03/24
3	AS SUBMITTED TO CITY FOR COMMENT	AP	10/05/24

REVISIONS

NOTES

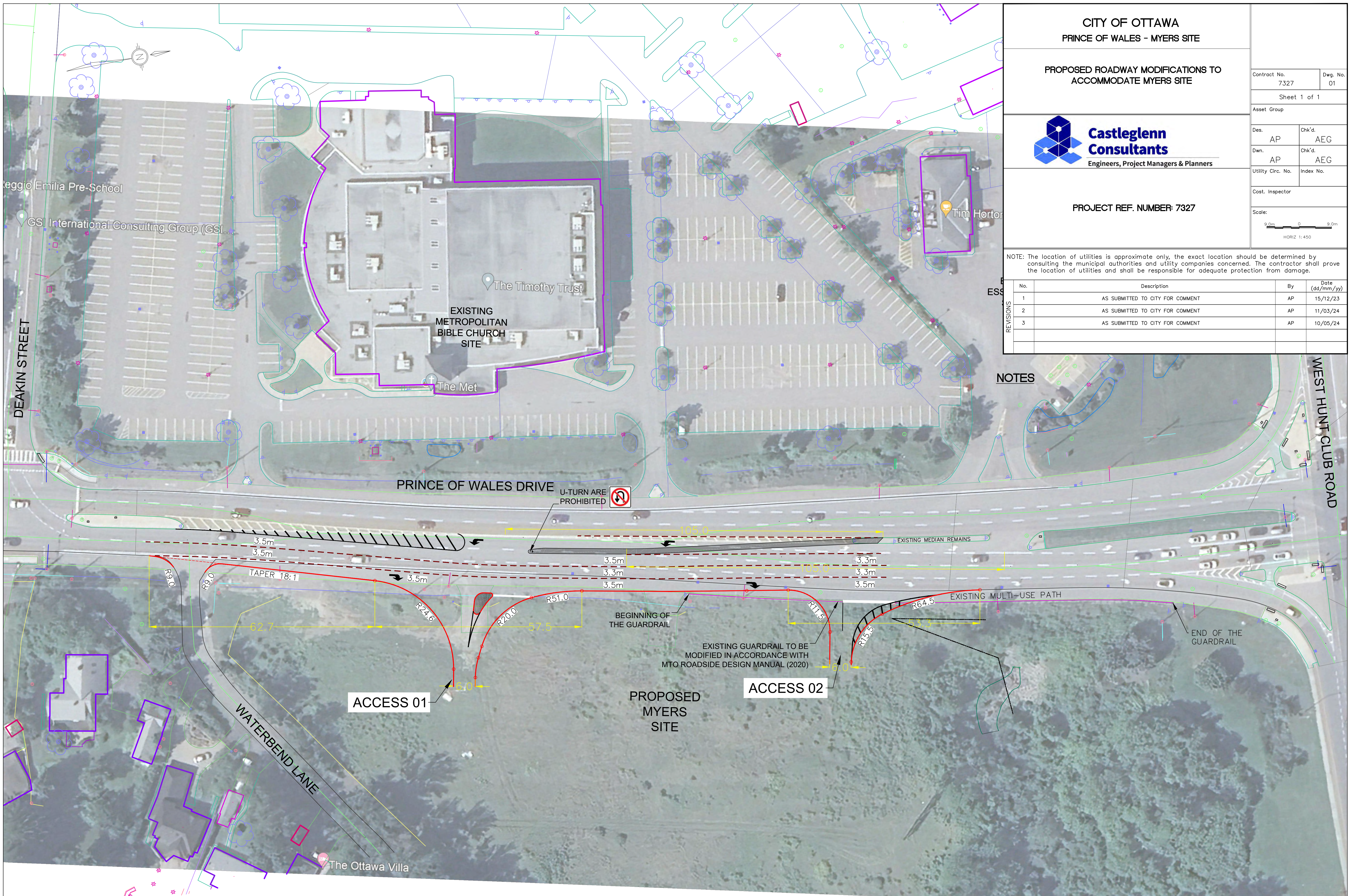

Reggio Emilia Pre-School

GS International Consulting Group (GSI...)

The Timothy Trust

EXISTING METROPOLITAN BIBLE CHURCH SITE

The Met

Tim Hortons

WATERBEND LANE

ACCESS 01

PROPOSED MYERS SITE

ACCESS 02

The Ottawa Villa

U-TURN ARE PROHIBITED



EXISTING MEDIAN REMAINS

EXISTING MULTI-USE PATH

BEGINNING OF THE GUARDRAIL

EXISTING GUARDRAIL TO BE MODIFIED IN ACCORDANCE WITH MTO ROADSIDE DESIGN MANUAL (2020)

END OF THE GUARDRAIL

PRINCE OF WALES DRIVE

DEAKIN STREET

WEST HUNT CLUB ROAD

APPENDIX “E”

SYNCHRO ANALYSIS OUTPUT SHEETS BACKGROUND (2025 AND 2030)

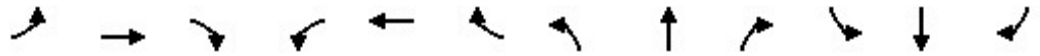

Lane Group	EBL	EBT	EBR	WBL	WBT	WBR	NBL	NBT	NBR	SBL	SBT	SBR
Lane Configurations	↕↕	↕↕	↕	↕↕	↕↕	↕	↕	↕↕	↕	↕↕	↕↕	↕
Traffic Volume (vph)	87	842	9	532	1106	450	67	732	932	284	415	210
Future Volume (vph)	87	842	9	532	1106	450	67	732	932	284	415	210
Ideal Flow (vphpl)	1800	1800	1800	1800	1800	1800	1800	1800	1800	1800	1800	1800
Lane Width (m)	3.7	3.5	4.8	3.7	3.5	3.7	3.7	3.5	4.8	3.7	3.5	3.5
Storage Length (m)	125.0		150.0	150.0		100.0	50.0		0.0	125.0		200.0
Storage Lanes	2		1	2		1	1		1	2		1
Taper Length (m)	7.6			7.6			7.6			7.6		
Lane Util. Factor	0.97	0.95	1.00	0.97	0.95	1.00	1.00	0.95	1.00	0.97	0.95	1.00
Ped Bike Factor	1.00		0.98	1.00		0.98	1.00		0.98	1.00		0.98
Fr _t			0.850			0.850			0.850			0.850
Fl _t Protected	0.950			0.950			0.950			0.950		
Satd. Flow (prot)	3022	3161	1535	3225	3252	1488	1662	3349	1683	3195	3221	1427
Fl _t Permitted	0.950			0.950			0.950			0.950		
Satd. Flow (perm)	3020	3161	1511	3222	3252	1465	1659	3349	1658	3188	3221	1405
Right Turn on Red			Yes			Yes			Yes			Yes
Satd. Flow (RTOR)			182			273			248			210
Link Speed (k/h)		80			80			60				60
Link Distance (m)		187.8			279.7			97.7				205.8
Travel Time (s)		8.5			12.6			5.9				12.3
Confl. Peds. (#/hr)	2		2	2		2	2		2	2		2
Peak Hour Factor	1.00	1.00	1.00	1.00	1.00	1.00	1.00	1.00	1.00	1.00	1.00	1.00
Heavy Vehicles (%)	11%	7%	13%	4%	4%	4%	4%	1%	3%	5%	5%	6%
Adj. Flow (vph)	87	842	9	532	1106	450	67	732	932	284	415	210
Shared Lane Traffic (%)												
Lane Group Flow (vph)	87	842	9	532	1106	450	67	732	932	284	415	210
Turn Type	Prot	NA	Perm	Prot	NA	Perm	Prot	NA	Perm	Prot	NA	Perm
Protected Phases	5	2		1	6		7	4		3	8	
Permitted Phases			2			6			4			8
Detector Phase	5	2	2	1	6	6	7	4	4	3	8	8
Switch Phase												
Minimum Initial (s)	1.0	1.0	1.0	1.0	1.0	1.0	1.0	1.0	1.0	1.0	1.0	1.0
Minimum Split (s)	11.6	31.8	31.8	11.6	34.2	34.2	11.6	31.6	31.6	11.6	31.6	31.6
Total Split (s)	16.0	48.0	48.0	28.0	60.0	60.0	20.0	44.0	44.0	20.0	44.0	44.0
Total Split (%)	11.4%	34.3%	34.3%	20.0%	42.9%	42.9%	14.3%	31.4%	31.4%	14.3%	31.4%	31.4%
Maximum Green (s)	9.4	41.2	41.2	21.4	53.2	53.2	13.4	37.4	37.4	13.4	37.4	37.4
Yellow Time (s)	3.7	4.6	4.6	3.7	4.6	4.6	3.7	3.7	3.7	3.7	3.7	3.7
All-Red Time (s)	2.9	2.2	2.2	2.9	2.2	2.2	2.9	2.9	2.9	2.9	2.9	2.9
Lost Time Adjust (s)	0.0	0.0	0.0	0.0	0.0	0.0	0.0	0.0	0.0	0.0	0.0	0.0
Total Lost Time (s)	6.6	6.8	6.8	6.6	6.8	6.8	6.6	6.6	6.6	6.6	6.6	6.6
Lead/Lag	Lead	Lag	Lag	Lead	Lag	Lag	Lead	Lag	Lag	Lead	Lag	Lag
Lead-Lag Optimize?	Yes	Yes	Yes	Yes	Yes	Yes	Yes	Yes	Yes	Yes	Yes	Yes
Vehicle Extension (s)	3.0	3.0	3.0	3.0	3.0	3.0	3.0	3.0	3.0	3.0	3.0	3.0
Recall Mode	None	C-Max	C-Max	None	C-Max	C-Max	None	Max	Max	None	Max	Max
Walk Time (s)		7.0	7.0		7.0	7.0		7.0	7.0		7.0	7.0
Flash Dont Walk (s)		18.0	18.0		18.0	18.0		17.0	17.0		17.0	17.0
Pedestrian Calls (#/hr)		2	2		2	2		2	2		2	2
Act Effct Green (s)	8.6	41.2	41.2	21.4	54.0	54.0	10.6	37.4	37.4	13.4	42.8	42.8
Actuated g/C Ratio	0.06	0.29	0.29	0.15	0.39	0.39	0.08	0.27	0.27	0.10	0.31	0.31

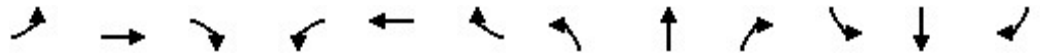

Lane Group	EBL	EBT	EBR	WBL	WBT	WBR	NBL	NBT	NBR	SBL	SBT	SBR
v/c Ratio	0.47	0.91	0.02	1.08	0.88	0.61	0.54	0.82	1.49	0.93	0.42	0.37
Control Delay	71.7	61.7	0.0	118.8	49.8	16.9	77.1	56.8	257.6	98.9	41.7	6.9
Queue Delay	0.0	0.0	0.0	0.0	0.0	0.0	0.0	0.0	0.0	0.0	0.0	0.0
Total Delay	71.7	61.7	0.0	118.8	49.8	16.9	77.1	56.8	257.6	98.9	41.7	6.9
LOS	E	E	A	F	D	B	E	E	F	F	D	A
Approach Delay		62.0			60.3			165.7			51.5	
Approach LOS		E			E			F			D	
Queue Length 50th (m)	11.1	109.0	0.0	~77.8	138.6	35.6	16.7	92.5	~280.7	37.6	45.9	0.0
Queue Length 95th (m)	19.5	#142.2	0.0	#110.6	#169.0	69.2	30.9	114.7	#353.8	#62.7	62.2	17.9
Internal Link Dist (m)		163.8			255.7			73.7			181.8	
Turn Bay Length (m)	125.0		150.0	150.0		100.0	50.0			125.0		200.0
Base Capacity (vph)	202	930	573	492	1253	732	159	894	624	305	985	575
Starvation Cap Reductn	0	0	0	0	0	0	0	0	0	0	0	0
Spillback Cap Reductn	0	0	0	0	0	0	0	0	0	0	0	0
Storage Cap Reductn	0	0	0	0	0	0	0	0	0	0	0	0
Reduced v/c Ratio	0.43	0.91	0.02	1.08	0.88	0.61	0.42	0.82	1.49	0.93	0.42	0.37

Intersection Summary

Area Type: Other
 Cycle Length: 140
 Actuated Cycle Length: 140
 Offset: 68 (49%), Referenced to phase 2:EBT and 6:WBT, Start of Green
 Natural Cycle: 150
 Control Type: Actuated-Coordinated
 Maximum v/c Ratio: 1.49
 Intersection Signal Delay: 91.4
 Intersection LOS: F
 Intersection Capacity Utilization 110.9%
 ICU Level of Service H
 Analysis Period (min) 15
 ~ Volume exceeds capacity, queue is theoretically infinite.
 Queue shown is maximum after two cycles.
 # 95th percentile volume exceeds capacity, queue may be longer.
 Queue shown is maximum after two cycles.

Splits and Phases: 3: Prince of Wales Drive & West Hunt Club Road/Hunt Club Road

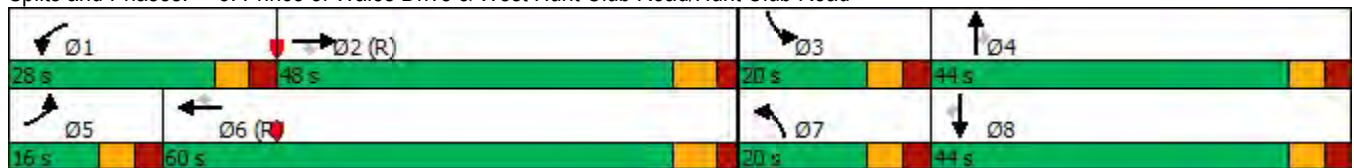

Lanes, Volumes, Timings
7: Prince of Wales Drive & Deakin Street

2175 Prince of Wales - 2025 AM- background
02/29/2024



Lane Group	EBL	EBR	NBL	NBT	SBT	SBR
Lane Configurations						
Traffic Volume (vph)	507	22	158	1238	560	401
Future Volume (vph)	507	22	158	1238	560	401
Ideal Flow (vphpl)	1800	1800	1800	1800	1800	1800
Storage Length (m)	70.0	0.0	100.0			0.0
Storage Lanes	1	0	1			0
Taper Length (m)	7.6		7.6			
Lane Util. Factor	0.97	0.95	1.00	0.95	0.95	0.95
Ped Bike Factor	1.00		1.00		0.99	
Frt	0.994				0.937	
Flt Protected	0.954		0.950			
Satd. Flow (prot)	3279	0	1695	3390	3144	0
Flt Permitted	0.954		0.266			
Satd. Flow (perm)	3272	0	474	3390	3144	0
Right Turn on Red		Yes				Yes
Satd. Flow (RTOR)	4				322	
Link Speed (k/h)	50			60	60	
Link Distance (m)	195.1			117.9	111.9	
Travel Time (s)	14.0			7.1	6.7	
Confl. Peds. (#/hr)	2	2	2			2
Peak Hour Factor	1.00	1.00	1.00	1.00	1.00	1.00
Adj. Flow (vph)	507	22	158	1238	560	401
Shared Lane Traffic (%)						
Lane Group Flow (vph)	529	0	158	1238	961	0
Turn Type	Prot		Perm	NA	NA	
Protected Phases	4			2	6	
Permitted Phases			2			
Detector Phase	4		2	2	6	
Switch Phase						
Minimum Initial (s)	1.0		5.0	5.0	5.0	
Minimum Split (s)	33.6		29.4	29.4	29.4	
Total Split (s)	33.6		67.0	67.0	67.0	
Total Split (%)	33.4%		66.6%	66.6%	66.6%	
Maximum Green (s)	27.0		60.6	60.6	60.6	
Yellow Time (s)	3.3		3.7	3.7	3.7	
All-Red Time (s)	3.3		2.7	2.7	2.7	
Lost Time Adjust (s)	0.0		0.0	0.0	0.0	
Total Lost Time (s)	6.6		6.4	6.4	6.4	
Lead/Lag						
Lead-Lag Optimize?						
Vehicle Extension (s)	3.0		3.0	3.0	3.0	
Recall Mode	None		C-Max	C-Max	C-Max	
Walk Time (s)	7.0		7.0	7.0	7.0	
Flash Dont Walk (s)	20.0		16.0	16.0	16.0	
Pedestrian Calls (#/hr)	2		2	2	2	
Act Effct Green (s)	21.4		66.2	66.2	66.2	
Actuated g/C Ratio	0.21		0.66	0.66	0.66	
v/c Ratio	0.76		0.51	0.55	0.44	
Control Delay	43.9		17.3	11.0	6.2	



Lane Group	EBL	EBR	NBL	NBT	SBT	SBR
Queue Delay	0.0		0.0	0.0	0.0	
Total Delay	43.9		17.3	11.0	6.2	
LOS	D		B	B	A	
Approach Delay	43.9			11.7	6.2	
Approach LOS	D			B	A	
Queue Length 50th (m)	45.9		13.1	56.5	23.8	
Queue Length 95th (m)	57.7		36.2	85.7	41.4	
Internal Link Dist (m)	171.1			93.9	87.9	
Turn Bay Length (m)	70.0		100.0			
Base Capacity (vph)	882		312	2231	2179	
Starvation Cap Reductn	0		0	0	0	
Spillback Cap Reductn	0		0	0	0	
Storage Cap Reductn	0		0	0	0	
Reduced v/c Ratio	0.60		0.51	0.55	0.44	

Intersection Summary

Area Type:	Other
Cycle Length:	100.6
Actuated Cycle Length:	100.6
Offset:	0 (0%), Referenced to phase 2:NBTL and 6:SBT, Start of Green
Natural Cycle:	80
Control Type:	Actuated-Coordinated
Maximum v/c Ratio:	0.76
Intersection Signal Delay:	15.8
Intersection LOS:	B
Intersection Capacity Utilization	71.8%
ICU Level of Service	C
Analysis Period (min)	15

Splits and Phases: 7: Prince of Wales Drive & Deakin Street

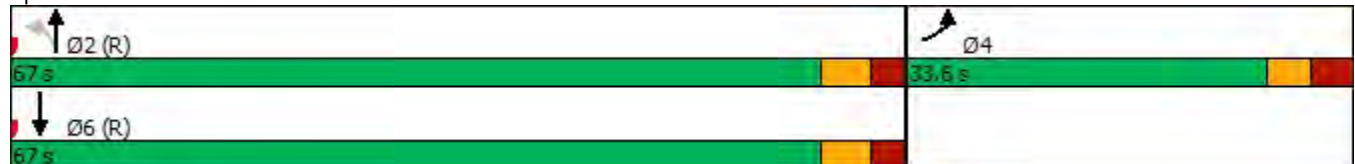

Intersection						
Int Delay, s/veh	0.6					
Movement	EBL	EBR	NBL	NBT	SBT	SBR
Lane Configurations		↗	↘	↑↑↑	↑↑↑	
Traffic Vol, veh/h	0	90	15	1731	871	84
Future Vol, veh/h	0	90	15	1731	871	84
Conflicting Peds, #/hr	20	20	20	0	0	20
Sign Control	Stop	Stop	Free	Free	Free	Free
RT Channelized	-	None	-	None	-	None
Storage Length	-	0	50	-	-	-
Veh in Median Storage, #	0	-	-	0	0	-
Grade, %	0	-	-	0	0	-
Peak Hour Factor	100	100	100	100	100	100
Heavy Vehicles, %	2	2	2	2	2	2
Mvmt Flow	0	90	15	1731	871	84

Major/Minor	Minor2	Major1	Major2		
Conflicting Flow All	-	518	975	0	-
Stage 1	-	-	-	-	-
Stage 2	-	-	-	-	-
Critical Hdwy	-	7.14	5.34	-	-
Critical Hdwy Stg 1	-	-	-	-	-
Critical Hdwy Stg 2	-	-	-	-	-
Follow-up Hdwy	-	3.92	3.12	-	-
Pot Cap-1 Maneuver	0	430	402	-	-
Stage 1	0	-	-	-	-
Stage 2	0	-	-	-	-
Platoon blocked, %				-	-
Mov Cap-1 Maneuver	-	411	391	-	-
Mov Cap-2 Maneuver	-	-	-	-	-
Stage 1	-	-	-	-	-
Stage 2	-	-	-	-	-

Approach	EB	NB	SB
HCM Control Delay, s	16.2	0.1	0
HCM LOS	C		

Minor Lane/Major Mvmt	NBL	NBT	EBLn1	SBT	SBR
Capacity (veh/h)	391	-	411	-	-
HCM Lane V/C Ratio	0.038	-	0.219	-	-
HCM Control Delay (s)	14.6	-	16.2	-	-
HCM Lane LOS	B	-	C	-	-
HCM 95th %tile Q(veh)	0.1	-	0.8	-	-

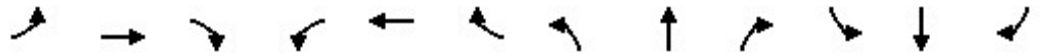

Lane Group	EBL	EBT	EBR	WBL	WBT	WBR	NBL	NBT	NBR	SBL	SBT	SBR
Lane Configurations												
Traffic Volume (vph)	103	1082	57	615	1242	344	29	455	750	451	807	117
Future Volume (vph)	103	1082	57	615	1242	344	29	455	750	451	807	117
Ideal Flow (vphpl)	1800	1800	1800	1800	1800	1800	1800	1800	1800	1800	1800	1800
Lane Width (m)	3.7	3.5	4.8	3.7	3.5	3.7	3.7	3.5	4.8	3.7	3.5	3.5
Storage Length (m)	125.0		150.0	150.0		100.0	50.0		0.0	125.0		200.0
Storage Lanes	2		1	2		1	1		1	2		1
Taper Length (m)	7.6			7.6			7.6			7.6		
Lane Util. Factor	0.97	0.95	1.00	0.97	0.95	1.00	1.00	0.95	1.00	0.97	0.95	1.00
Ped Bike Factor	1.00		0.98	1.00		0.98	1.00		0.98	1.00		0.98
Fr _t			0.850			0.850			0.850			0.850
Fl _t Protected	0.950			0.950			0.950			0.950		
Satd. Flow (prot)	3288	3283	1651	3321	3252	1488	1729	3316	1717	3195	3349	1455
Fl _t Permitted	0.950			0.950			0.950			0.950		
Satd. Flow (perm)	3286	3283	1626	3318	3252	1464	1727	3316	1690	3184	3349	1432
Right Turn on Red			Yes			Yes			Yes			Yes
Satd. Flow (RTOR)			218			344			218			170
Link Speed (k/h)		80			80			60				60
Link Distance (m)		187.8			279.7			97.7				205.8
Travel Time (s)		8.5			12.6			5.9				12.3
Confl. Peds. (#/hr)	2		2	2		2	2		2	2		2
Peak Hour Factor	1.00	1.00	1.00	1.00	1.00	1.00	1.00	1.00	1.00	1.00	1.00	1.00
Heavy Vehicles (%)	2%	3%	5%	1%	4%	4%	0%	2%	1%	5%	1%	4%
Adj. Flow (vph)	103	1082	57	615	1242	344	29	455	750	451	807	117
Shared Lane Traffic (%)												
Lane Group Flow (vph)	103	1082	57	615	1242	344	29	455	750	451	807	117
Turn Type	Prot	NA	Perm	Prot	NA	Perm	Prot	NA	Perm	Prot	NA	Perm
Protected Phases	5	2		1	6		7	4		3	8	
Permitted Phases			2			6			4			8
Detector Phase	5	2	2	1	6	6	7	4	4	3	8	8
Switch Phase												
Minimum Initial (s)	5.0	5.0	5.0	5.0	5.0	5.0	5.0	5.0	5.0	5.0	5.0	5.0
Minimum Split (s)	11.6	30.6	30.6	11.6	31.6	31.6	11.6	30.6	30.6	11.6	31.6	31.6
Total Split (s)	15.0	63.0	63.0	28.0	76.0	76.0	13.0	31.0	31.0	28.0	46.0	46.0
Total Split (%)	10.0%	42.0%	42.0%	18.7%	50.7%	50.7%	8.7%	20.7%	20.7%	18.7%	30.7%	30.7%
Maximum Green (s)	8.4	56.4	56.4	21.4	69.4	69.4	6.4	24.4	24.4	21.4	39.4	39.4
Yellow Time (s)	3.7	3.7	3.7	3.7	3.7	3.7	3.7	3.7	3.7	3.7	3.7	3.7
All-Red Time (s)	2.9	2.9	2.9	2.9	2.9	2.9	2.9	2.9	2.9	2.9	2.9	2.9
Lost Time Adjust (s)	0.0	0.0	0.0	0.0	0.0	0.0	0.0	0.0	0.0	0.0	0.0	0.0
Total Lost Time (s)	6.6	6.6	6.6	6.6	6.6	6.6	6.6	6.6	6.6	6.6	6.6	6.6
Lead/Lag	Lead	Lag	Lag	Lead	Lag	Lag	Lead	Lag	Lag	Lead	Lag	Lag
Lead-Lag Optimize?	Yes	Yes	Yes	Yes	Yes	Yes	Yes	Yes	Yes	Yes	Yes	Yes
Vehicle Extension (s)	3.0	3.0	3.0	3.0	3.0	3.0	3.0	3.0	3.0	3.0	3.0	3.0
Recall Mode	None	C-Max	C-Max	None	C-Max	C-Max	None	Max	Max	None	Max	Max
Walk Time (s)		7.0	7.0		7.0	7.0		7.0	7.0		7.0	7.0
Flash Dont Walk (s)		17.0	17.0		18.0	18.0		17.0	17.0		18.0	18.0
Pedestrian Calls (#/hr)		2	2		2	2		2	2		2	2
Act Effct Green (s)	8.2	56.4	56.4	21.4	69.6	69.6	6.2	24.4	24.4	21.4	44.6	44.6
Actuated g/C Ratio	0.05	0.38	0.38	0.14	0.46	0.46	0.04	0.16	0.16	0.14	0.30	0.30



Lane Group	EBL	EBT	EBR	WBL	WBT	WBR	NBL	NBT	NBR	SBL	SBT	SBR
v/c Ratio	0.58	0.88	0.08	1.30	0.82	0.40	0.41	0.84	1.64	0.99	0.81	0.21
Control Delay	82.3	52.9	0.2	198.6	40.6	3.6	87.1	75.9	324.7	103.3	57.1	2.0
Queue Delay	0.0	0.0	0.0	0.0	0.0	0.0	0.0	0.0	0.0	0.0	0.0	0.0
Total Delay	82.3	52.9	0.2	198.6	40.6	3.6	87.1	75.9	324.7	103.3	57.1	2.0
LOS	F	D	A	F	D	A	F	E	F	F	E	A
Approach Delay		52.9			79.0			227.4			67.5	
Approach LOS		D			E			F			E	
Queue Length 50th (m)	14.4	144.7	0.0	~110.7	153.4	0.0	7.9	64.5	~245.1	64.5	113.8	0.0
Queue Length 95th (m)	23.9	172.2	0.0	#145.5	181.3	15.6	18.1	#88.0	#316.5	#97.2	#147.1	2.9
Internal Link Dist (m)		163.8			255.7			73.7			181.8	
Turn Bay Length (m)	125.0		150.0	150.0		100.0	50.0		125.0			200.0
Base Capacity (vph)	184	1234	747	473	1509	864	73	539	457	455	995	545
Starvation Cap Reductn	0	0	0	0	0	0	0	0	0	0	0	0
Spillback Cap Reductn	0	0	0	0	0	0	0	0	0	0	0	0
Storage Cap Reductn	0	0	0	0	0	0	0	0	0	0	0	0
Reduced v/c Ratio	0.56	0.88	0.08	1.30	0.82	0.40	0.40	0.84	1.64	0.99	0.81	0.21

Intersection Summary

Area Type: Other
 Cycle Length: 150
 Actuated Cycle Length: 150
 Offset: 31 (21%), Referenced to phase 2:EBT and 6:WBT, Start of Green
 Natural Cycle: 150
 Control Type: Actuated-Coordinated
 Maximum v/c Ratio: 1.64
 Intersection Signal Delay: 101.3
 Intersection LOS: F
 Intersection Capacity Utilization 110.9%
 ICU Level of Service H
 Analysis Period (min) 15
 ~ Volume exceeds capacity, queue is theoretically infinite.
 Queue shown is maximum after two cycles.
 # 95th percentile volume exceeds capacity, queue may be longer.
 Queue shown is maximum after two cycles.

Splits and Phases: 3: Prince of Wales Drive & West Hunt Club Road/Hunt Club Road

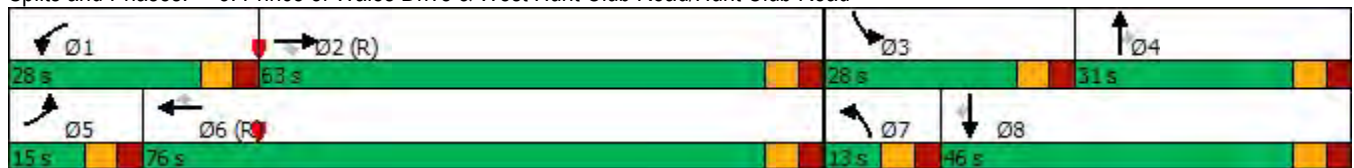

Lanes, Volumes, Timings
7: Prince of Wales Drive & Deakin Street

2175 Prince of Wales - 2025 PM- background
03/01/2024



Lane Group	EBL	EBR	NBL	NBT	SBT	SBR
Lane Configurations						
Traffic Volume (vph)	465	187	34	775	1311	172
Future Volume (vph)	465	187	34	775	1311	172
Ideal Flow (vphpl)	1800	1800	1800	1800	1800	1800
Storage Length (m)	70.0	0.0	100.0			0.0
Storage Lanes	1	0	1			0
Taper Length (m)	7.6		7.6			
Lane Util. Factor	0.97	0.95	1.00	0.95	0.95	0.95
Ped Bike Factor	0.95				0.99	
Fr _t	0.957				0.983	
Fl _t Protected	0.966		0.950			
Satd. Flow (prot)	3122	0	1729	3390	3317	0
Fl _t Permitted	0.966		0.126			
Satd. Flow (perm)	3033	0	229	3390	3317	0
Right Turn on Red		Yes				Yes
Satd. Flow (RTOR)	48				26	
Link Speed (k/h)	50			60	60	
Link Distance (m)	195.1			117.9	111.9	
Travel Time (s)	14.0			7.1	6.7	
Confl. Peds. (#/hr)	20	20	20			20
Peak Hour Factor	1.00	1.00	1.00	1.00	1.00	1.00
Heavy Vehicles (%)	2%	2%	0%	2%	1%	5%
Adj. Flow (vph)	465	187	34	775	1311	172
Shared Lane Traffic (%)						
Lane Group Flow (vph)	652	0	34	775	1483	0
Turn Type	Prot		Perm	NA	NA	
Protected Phases	4			2	6	
Permitted Phases			2			
Detector Phase	4		2	2	6	
Switch Phase						
Minimum Initial (s)	5.0		5.0	5.0	5.0	
Minimum Split (s)	24.6		24.4	24.4	24.4	
Total Split (s)	33.0		87.0	87.0	87.0	
Total Split (%)	27.5%		72.5%	72.5%	72.5%	
Maximum Green (s)	26.4		80.6	80.6	80.6	
Yellow Time (s)	3.3		3.7	3.7	3.7	
All-Red Time (s)	3.3		2.7	2.7	2.7	
Lost Time Adjust (s)	0.0		0.0	0.0	0.0	
Total Lost Time (s)	6.6		6.4	6.4	6.4	
Lead/Lag						
Lead-Lag Optimize?						
Vehicle Extension (s)	3.0		3.0	3.0	3.0	
Recall Mode	None		C-Max	C-Max	C-Max	
Walk Time (s)	7.0		7.0	7.0	7.0	
Flash Dont Walk (s)	11.0		11.0	11.0	11.0	
Pedestrian Calls (#/hr)	0		0	0	0	
Act Effct Green (s)	25.7		81.3	81.3	81.3	
Actuated g/C Ratio	0.21		0.68	0.68	0.68	
v/c Ratio	0.92		0.22	0.34	0.66	



Lane Group	EBL	EBR	NBL	NBT	SBT	SBR
Control Delay	62.3		11.9	8.7	12.9	
Queue Delay	0.0		0.0	0.0	0.0	
Total Delay	62.3		11.9	8.7	12.9	
LOS	E		B	A	B	
Approach Delay	62.3			8.8	12.9	
Approach LOS	E			A	B	
Queue Length 50th (m)	66.6		2.6	34.3	89.9	
Queue Length 95th (m)	#96.2		7.7	43.4	109.9	
Internal Link Dist (m)	171.1			93.9	87.9	
Turn Bay Length (m)	70.0		100.0			
Base Capacity (vph)	724		154	2295	2254	
Starvation Cap Reductn	0		0	0	0	
Spillback Cap Reductn	0		0	0	0	
Storage Cap Reductn	0		0	0	0	
Reduced v/c Ratio	0.90		0.22	0.34	0.66	

Intersection Summary

Area Type: Other
 Cycle Length: 120
 Actuated Cycle Length: 120
 Offset: 1 (1%), Referenced to phase 2:NBT and 6:SBT, Start of Green
 Natural Cycle: 60
 Control Type: Actuated-Coordinated
 Maximum v/c Ratio: 0.92
 Intersection Signal Delay: 22.7
 Intersection LOS: C
 Intersection Capacity Utilization 75.9%
 ICU Level of Service D
 Analysis Period (min) 15
 # 95th percentile volume exceeds capacity, queue may be longer.
 Queue shown is maximum after two cycles.

Splits and Phases: 7: Prince of Wales Drive & Deakin Street

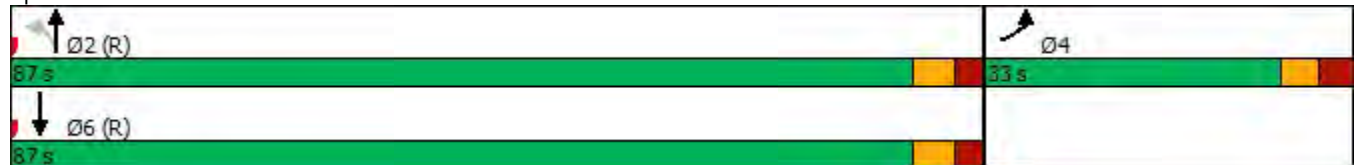

Intersection						
Int Delay, s/veh	0.3					
Movement	EBL	EBR	NBL	NBT	SBT	SBR
Lane Configurations		↗	↘	↑↑↑	↑↑↑	
Traffic Vol, veh/h	0	36	6	1234	1446	32
Future Vol, veh/h	0	36	6	1234	1446	32
Conflicting Peds, #/hr	20	20	20	0	0	20
Sign Control	Stop	Stop	Free	Free	Free	Free
RT Channelized	-	None	-	None	-	None
Storage Length	-	0	50	-	-	-
Veh in Median Storage, #	0	-	-	0	0	-
Grade, %	0	-	-	0	0	-
Peak Hour Factor	100	100	100	100	100	100
Heavy Vehicles, %	2	2	2	2	2	2
Mvmt Flow	0	36	6	1234	1446	32

Major/Minor	Minor2	Major1	Major2			
Conflicting Flow All	-	779	1498	0	-	0
Stage 1	-	-	-	-	-	-
Stage 2	-	-	-	-	-	-
Critical Hdwy	-	7.14	5.34	-	-	-
Critical Hdwy Stg 1	-	-	-	-	-	-
Critical Hdwy Stg 2	-	-	-	-	-	-
Follow-up Hdwy	-	3.92	3.12	-	-	-
Pot Cap-1 Maneuver	0	291	223	-	-	-
Stage 1	0	-	-	-	-	-
Stage 2	0	-	-	-	-	-
Platoon blocked, %				-	-	-
Mov Cap-1 Maneuver	-	278	217	-	-	-
Mov Cap-2 Maneuver	-	-	-	-	-	-
Stage 1	-	-	-	-	-	-
Stage 2	-	-	-	-	-	-

Approach	EB	NB	SB
HCM Control Delay, s	19.9	0.1	0
HCM LOS	C		

Minor Lane/Major Mvmt	NBL	NBT	EBLn1	SBT	SBR
Capacity (veh/h)	217	-	278	-	-
HCM Lane V/C Ratio	0.028	-	0.129	-	-
HCM Control Delay (s)	22.1	-	19.9	-	-
HCM Lane LOS	C	-	C	-	-
HCM 95th %tile Q(veh)	0.1	-	0.4	-	-

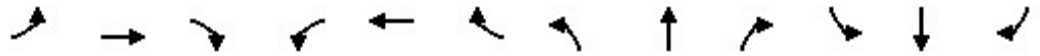

Lane Group	EBL	EBT	EBR	WBL	WBT	WBR	NBL	NBT	NBR	SBL	SBT	SBR
Lane Configurations	↗↗	↑↑	↖	↗↗	↑↑	↖	↖	↑↑	↖	↗↗	↑↑	↖
Traffic Volume (vph)	89	863	9	545	1133	462	68	750	955	291	425	215
Future Volume (vph)	89	863	9	545	1133	462	68	750	955	291	425	215
Ideal Flow (vphpl)	1800	1800	1800	1800	1800	1800	1800	1800	1800	1800	1800	1800
Lane Width (m)	3.7	3.5	4.8	3.7	3.5	3.7	3.7	3.5	4.8	3.7	3.5	3.5
Storage Length (m)	125.0		150.0	150.0		100.0	50.0		0.0	125.0		200.0
Storage Lanes	2		1	2		1	1		1	2		1
Taper Length (m)	7.6			7.6			7.6			7.6		
Lane Util. Factor	0.97	0.95	1.00	0.97	0.95	1.00	1.00	0.95	1.00	0.97	0.95	1.00
Ped Bike Factor	1.00		0.98	1.00		0.98	1.00		0.98	1.00		0.98
Frt			0.850			0.850			0.850			0.850
Flt Protected	0.950			0.950			0.950			0.950		
Satd. Flow (prot)	3022	3161	1535	3225	3252	1488	1662	3349	1683	3195	3221	1427
Flt Permitted	0.950			0.950			0.950			0.950		
Satd. Flow (perm)	3020	3161	1511	3222	3252	1465	1659	3349	1658	3188	3221	1405
Right Turn on Red			Yes			Yes			Yes			Yes
Satd. Flow (RTOR)			182			271			246			209
Link Speed (k/h)		80			80			60				60
Link Distance (m)		187.8			279.7			97.7				205.8
Travel Time (s)		8.5			12.6			5.9				12.3
Confl. Peds. (#/hr)	2		2	2		2	2		2	2		2
Peak Hour Factor	1.00	1.00	1.00	1.00	1.00	1.00	1.00	1.00	1.00	1.00	1.00	1.00
Heavy Vehicles (%)	11%	7%	13%	4%	4%	4%	4%	1%	3%	5%	5%	6%
Adj. Flow (vph)	89	863	9	545	1133	462	68	750	955	291	425	215
Shared Lane Traffic (%)												
Lane Group Flow (vph)	89	863	9	545	1133	462	68	750	955	291	425	215
Turn Type	Prot	NA	Perm	Prot	NA	Perm	Prot	NA	Perm	Prot	NA	Perm
Protected Phases	5	2		1	6		7	4		3	8	
Permitted Phases			2			6			4			8
Detector Phase	5	2	2	1	6	6	7	4	4	3	8	8
Switch Phase												
Minimum Initial (s)	1.0	1.0	1.0	1.0	1.0	1.0	1.0	1.0	1.0	1.0	1.0	1.0
Minimum Split (s)	11.6	31.8	31.8	11.6	34.2	34.2	11.6	31.6	31.6	11.6	31.6	31.6
Total Split (s)	16.0	48.0	48.0	28.0	60.0	60.0	20.0	44.0	44.0	20.0	44.0	44.0
Total Split (%)	11.4%	34.3%	34.3%	20.0%	42.9%	42.9%	14.3%	31.4%	31.4%	14.3%	31.4%	31.4%
Maximum Green (s)	9.4	41.2	41.2	21.4	53.2	53.2	13.4	37.4	37.4	13.4	37.4	37.4
Yellow Time (s)	3.7	4.6	4.6	3.7	4.6	4.6	3.7	3.7	3.7	3.7	3.7	3.7
All-Red Time (s)	2.9	2.2	2.2	2.9	2.2	2.2	2.9	2.9	2.9	2.9	2.9	2.9
Lost Time Adjust (s)	0.0	0.0	0.0	0.0	0.0	0.0	0.0	0.0	0.0	0.0	0.0	0.0
Total Lost Time (s)	6.6	6.8	6.8	6.6	6.8	6.8	6.6	6.6	6.6	6.6	6.6	6.6
Lead/Lag	Lead	Lag	Lag	Lead	Lag	Lag	Lead	Lag	Lag	Lead	Lag	Lag
Lead-Lag Optimize?	Yes	Yes	Yes	Yes	Yes	Yes	Yes	Yes	Yes	Yes	Yes	Yes
Vehicle Extension (s)	3.0	3.0	3.0	3.0	3.0	3.0	3.0	3.0	3.0	3.0	3.0	3.0
Recall Mode	None	C-Max	C-Max	None	C-Max	C-Max	None	Max	Max	None	Max	Max
Walk Time (s)		7.0	7.0		7.0	7.0		7.0	7.0		7.0	7.0
Flash Dont Walk (s)		18.0	18.0		18.0	18.0		17.0	17.0		17.0	17.0
Pedestrian Calls (#/hr)		2	2		2	2		2	2		2	2
Act Effct Green (s)	8.7	41.2	41.2	21.4	53.9	53.9	10.6	37.4	37.4	13.4	42.8	42.8
Actuated g/C Ratio	0.06	0.29	0.29	0.15	0.38	0.38	0.08	0.27	0.27	0.10	0.31	0.31



Lane Group	EBL	EBT	EBR	WBL	WBT	WBR	NBL	NBT	NBR	SBL	SBT	SBR
v/c Ratio	0.48	0.93	0.02	1.11	0.90	0.63	0.54	0.84	1.53	0.95	0.43	0.37
Control Delay	72.0	64.6	0.0	126.6	51.9	18.1	77.4	58.1	274.7	103.4	42.0	7.5
Queue Delay	0.0	0.0	0.0	0.0	0.0	0.0	0.0	0.0	0.0	0.0	0.0	0.0
Total Delay	72.0	64.6	0.0	126.6	51.9	18.1	77.4	58.1	274.7	103.4	42.0	7.5
LOS	E	E	A	F	D	B	E	E	F	F	D	A
Approach Delay		64.7			63.6			175.5			53.2	
Approach LOS		E			E			F			D	
Queue Length 50th (m)	11.4	112.8	0.0	~81.4	143.8	39.3	17.0	95.5	~293.9	38.7	47.2	1.1
Queue Length 95th (m)	19.8	#148.1	0.0	#114.4	#182.4	74.1	31.2	118.0	#367.4	#64.6	63.7	19.4
Internal Link Dist (m)		163.8			255.7			73.7			181.8	
Turn Bay Length (m)	125.0		150.0	150.0		100.0	50.0			125.0		200.0
Base Capacity (vph)	202	930	573	492	1252	730	159	894	623	305	984	574
Starvation Cap Reductn	0	0	0	0	0	0	0	0	0	0	0	0
Spillback Cap Reductn	0	0	0	0	0	0	0	0	0	0	0	0
Storage Cap Reductn	0	0	0	0	0	0	0	0	0	0	0	0
Reduced v/c Ratio	0.44	0.93	0.02	1.11	0.90	0.63	0.43	0.84	1.53	0.95	0.43	0.37

Intersection Summary

Area Type: Other
 Cycle Length: 140
 Actuated Cycle Length: 140
 Offset: 68 (49%), Referenced to phase 2:EBT and 6:WBT, Start of Green
 Natural Cycle: 150
 Control Type: Actuated-Coordinated
 Maximum v/c Ratio: 1.53
 Intersection Signal Delay: 96.3
 Intersection Capacity Utilization 113.2%
 Analysis Period (min) 15
 Intersection LOS: F
 ICU Level of Service H

~ Volume exceeds capacity, queue is theoretically infinite.
 Queue shown is maximum after two cycles.

95th percentile volume exceeds capacity, queue may be longer.
 Queue shown is maximum after two cycles.

Splits and Phases: 3: Prince of Wales Drive & West Hunt Club Road/Hunt Club Road

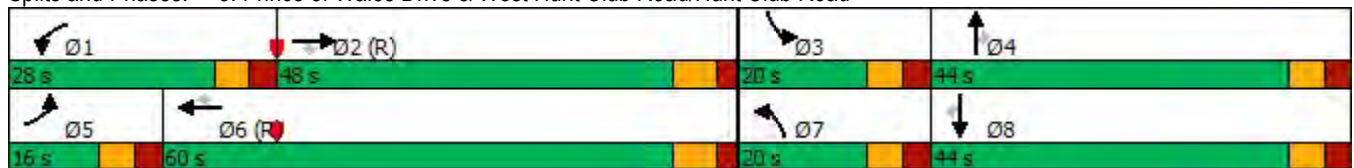

Lanes, Volumes, Timings
7: Prince of Wales Drive & Deakin Street

2175 Prince of Wales - 2030 AM- background only

03/01/2024



Lane Group	EBL	EBR	NBL	NBT	SBT	SBR
Lane Configurations						
Traffic Volume (vph)	520	23	161	1269	573	411
Future Volume (vph)	520	23	161	1269	573	411
Ideal Flow (vphpl)	1800	1800	1800	1800	1800	1800
Storage Length (m)	70.0	0.0	100.0			0.0
Storage Lanes	1	0	1			0
Taper Length (m)	7.6		7.6			
Lane Util. Factor	0.97	0.95	1.00	0.95	0.95	0.95
Ped Bike Factor	1.00		1.00		0.99	
Frt	0.994				0.937	
Flt Protected	0.954		0.950			
Satd. Flow (prot)	3279	0	1695	3390	3144	0
Flt Permitted	0.954		0.258			
Satd. Flow (perm)	3272	0	460	3390	3144	0
Right Turn on Red		Yes				Yes
Satd. Flow (RTOR)	4				324	
Link Speed (k/h)	50			60	60	
Link Distance (m)	195.1			117.9	111.9	
Travel Time (s)	14.0			7.1	6.7	
Confl. Peds. (#/hr)	2	2	2			2
Peak Hour Factor	1.00	1.00	1.00	1.00	1.00	1.00
Adj. Flow (vph)	520	23	161	1269	573	411
Shared Lane Traffic (%)						
Lane Group Flow (vph)	543	0	161	1269	984	0
Turn Type	Prot		Perm	NA	NA	
Protected Phases	4			2	6	
Permitted Phases			2			
Detector Phase	4		2	2	6	
Switch Phase						
Minimum Initial (s)	1.0		5.0	5.0	5.0	
Minimum Split (s)	33.6		29.4	29.4	29.4	
Total Split (s)	33.6		67.0	67.0	67.0	
Total Split (%)	33.4%		66.6%	66.6%	66.6%	
Maximum Green (s)	27.0		60.6	60.6	60.6	
Yellow Time (s)	3.3		3.7	3.7	3.7	
All-Red Time (s)	3.3		2.7	2.7	2.7	
Lost Time Adjust (s)	0.0		0.0	0.0	0.0	
Total Lost Time (s)	6.6		6.4	6.4	6.4	
Lead/Lag						
Lead-Lag Optimize?						
Vehicle Extension (s)	3.0		3.0	3.0	3.0	
Recall Mode	None		C-Max	C-Max	C-Max	
Walk Time (s)	7.0		7.0	7.0	7.0	
Flash Dont Walk (s)	20.0		16.0	16.0	16.0	
Pedestrian Calls (#/hr)	2		2	2	2	
Act Effct Green (s)	21.7		65.9	65.9	65.9	
Actuated g/C Ratio	0.22		0.66	0.66	0.66	
v/c Ratio	0.76		0.53	0.57	0.45	
Control Delay	44.0		18.8	11.4	6.5	



Lane Group	EBL	EBR	NBL	NBT	SBT	SBR
Queue Delay	0.0		0.0	0.0	0.0	
Total Delay	44.0		18.8	11.4	6.5	
LOS	D		B	B	A	
Approach Delay	44.0			12.3	6.5	
Approach LOS	D			B	A	
Queue Length 50th (m)	47.1		13.8	59.6	25.4	
Queue Length 95th (m)	59.3		38.6	89.0	43.2	
Internal Link Dist (m)	171.1			93.9	87.9	
Turn Bay Length (m)	70.0		100.0			
Base Capacity (vph)	882		301	2220	2170	
Starvation Cap Reductn	0		0	0	0	
Spillback Cap Reductn	0		0	0	0	
Storage Cap Reductn	0		0	0	0	
Reduced v/c Ratio	0.62		0.53	0.57	0.45	

Intersection Summary

Area Type:	Other
Cycle Length:	100.6
Actuated Cycle Length:	100.6
Offset: 0 (0%), Referenced to phase 2:NBTL and 6:SBT, Start of Green	
Natural Cycle:	80
Control Type:	Actuated-Coordinated
Maximum v/c Ratio:	0.76
Intersection Signal Delay:	16.2
Intersection LOS:	B
Intersection Capacity Utilization	73.1%
ICU Level of Service	D
Analysis Period (min)	15

Splits and Phases: 7: Prince of Wales Drive & Deakin Street

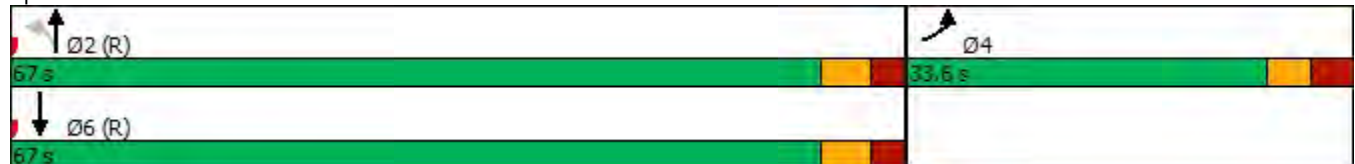

Intersection						
Int Delay, s/veh	0.5					
Movement	EBL	EBR	NBL	NBT	SBT	SBR
Lane Configurations		↗	↘	↑↑↑	↑↑↑	
Traffic Vol, veh/h	0	90	15	2500	892	84
Future Vol, veh/h	0	90	15	2500	892	84
Conflicting Peds, #/hr	20	20	20	0	0	20
Sign Control	Stop	Stop	Free	Free	Free	Free
RT Channelized	-	None	-	None	-	None
Storage Length	-	0	50	-	-	-
Veh in Median Storage, #	0	-	-	0	0	-
Grade, %	0	-	-	0	0	-
Peak Hour Factor	100	100	100	100	100	100
Heavy Vehicles, %	2	2	2	2	2	2
Mvmt Flow	0	90	15	2500	892	84

Major/Minor	Minor2	Major1	Major2		
Conflicting Flow All	-	528	996	0	-
Stage 1	-	-	-	-	-
Stage 2	-	-	-	-	-
Critical Hdwy	-	7.14	5.34	-	-
Critical Hdwy Stg 1	-	-	-	-	-
Critical Hdwy Stg 2	-	-	-	-	-
Follow-up Hdwy	-	3.92	3.12	-	-
Pot Cap-1 Maneuver	0	424	393	-	-
Stage 1	0	-	-	-	-
Stage 2	0	-	-	-	-
Platoon blocked, %				-	-
Mov Cap-1 Maneuver	-	405	382	-	-
Mov Cap-2 Maneuver	-	-	-	-	-
Stage 1	-	-	-	-	-
Stage 2	-	-	-	-	-

Approach	EB	NB	SB
HCM Control Delay, s	16.4	0.1	0
HCM LOS	C		

Minor Lane/Major Mvmt	NBL	NBT	EBLn1	SBT	SBR
Capacity (veh/h)	382	-	405	-	-
HCM Lane V/C Ratio	0.039	-	0.222	-	-
HCM Control Delay (s)	14.8	-	16.4	-	-
HCM Lane LOS	B	-	C	-	-
HCM 95th %tile Q(veh)	0.1	-	0.8	-	-

Lanes, Volumes, Timings 2175 Prince of Wales - 2030 PM - background only not optimized
 3: Prince of Wales Drive & West Hunt Club Road/Hunt Club Road 03/01/2024



Lane Group	EBL	EBT	EBR	WBL	WBT	WBR	NBL	NBT	NBR	SBL	SBT	SBR
Lane Configurations	↖↖	↗↗	↖	↖↖	↗↗	↖	↖	↗↗	↖	↖↖	↗↗	↖
Traffic Volume (vph)	106	1108	58	630	1273	353	30	466	769	463	827	120
Future Volume (vph)	106	1108	58	630	1273	353	30	466	769	463	827	120
Ideal Flow (vphpl)	1800	1800	1800	1800	1800	1800	1800	1800	1800	1800	1800	1800
Lane Width (m)	3.7	3.5	4.8	3.7	3.5	3.7	3.7	3.5	4.8	3.7	3.5	3.5
Storage Length (m)	125.0		150.0	150.0		100.0	50.0		0.0	125.0		200.0
Storage Lanes	2		1	2		1	1		1	2		1
Taper Length (m)	7.6			7.6			7.6			7.6		
Lane Util. Factor	0.97	0.95	1.00	0.97	0.95	1.00	1.00	0.95	1.00	0.97	0.95	1.00
Ped Bike Factor	1.00		0.98	1.00		0.98	1.00		0.98	1.00		0.98
Fr _t			0.850			0.850			0.850			0.850
Fl _t Protected	0.950			0.950			0.950			0.950		
Satd. Flow (prot)	3288	3283	1651	3321	3252	1488	1729	3316	1717	3195	3349	1455
Fl _t Permitted	0.950			0.950			0.950			0.950		
Satd. Flow (perm)	3287	3283	1626	3318	3252	1464	1727	3316	1690	3184	3349	1432
Right Turn on Red			Yes			Yes			Yes			Yes
Satd. Flow (RTOR)			218			353			218			170
Link Speed (k/h)		80			80			60			60	
Link Distance (m)		187.8			279.7			97.7			205.8	
Travel Time (s)		8.5			12.6			5.9			12.3	
Confl. Peds. (#/hr)	2		2	2		2	2		2	2		2
Peak Hour Factor	1.00	1.00	1.00	1.00	1.00	1.00	1.00	1.00	1.00	1.00	1.00	1.00
Heavy Vehicles (%)	2%	3%	5%	1%	4%	4%	0%	2%	1%	5%	1%	4%
Adj. Flow (vph)	106	1108	58	630	1273	353	30	466	769	463	827	120
Shared Lane Traffic (%)												
Lane Group Flow (vph)	106	1108	58	630	1273	353	30	466	769	463	827	120
Turn Type	Prot	NA	Perm	Prot	NA	Perm	Prot	NA	Perm	Prot	NA	Perm
Protected Phases	5	2		1	6		7	4		3	8	
Permitted Phases			2			6			4			8
Detector Phase	5	2	2	1	6	6	7	4	4	3	8	8
Switch Phase												
Minimum Initial (s)	5.0	5.0	5.0	5.0	5.0	5.0	5.0	5.0	5.0	5.0	5.0	5.0
Minimum Split (s)	11.6	30.6	30.6	11.6	31.6	31.6	11.6	30.6	30.6	11.6	31.6	31.6
Total Split (s)	15.0	63.0	63.0	28.0	76.0	76.0	13.0	31.0	31.0	28.0	46.0	46.0
Total Split (%)	10.0%	42.0%	42.0%	18.7%	50.7%	50.7%	8.7%	20.7%	20.7%	18.7%	30.7%	30.7%
Maximum Green (s)	8.4	56.4	56.4	21.4	69.4	69.4	6.4	24.4	24.4	21.4	39.4	39.4
Yellow Time (s)	3.7	3.7	3.7	3.7	3.7	3.7	3.7	3.7	3.7	3.7	3.7	3.7
All-Red Time (s)	2.9	2.9	2.9	2.9	2.9	2.9	2.9	2.9	2.9	2.9	2.9	2.9
Lost Time Adjust (s)	0.0	0.0	0.0	0.0	0.0	0.0	0.0	0.0	0.0	0.0	0.0	0.0
Total Lost Time (s)	6.6	6.6	6.6	6.6	6.6	6.6	6.6	6.6	6.6	6.6	6.6	6.6
Lead/Lag	Lead	Lag	Lag	Lead	Lag	Lag	Lead	Lag	Lag	Lead	Lag	Lag
Lead-Lag Optimize?	Yes	Yes	Yes	Yes	Yes	Yes	Yes	Yes	Yes	Yes	Yes	Yes
Vehicle Extension (s)	3.0	3.0	3.0	3.0	3.0	3.0	3.0	3.0	3.0	3.0	3.0	3.0
Recall Mode	None	C-Max	C-Max	None	C-Max	C-Max	None	Max	Max	None	Max	Max
Walk Time (s)		7.0	7.0		7.0	7.0		7.0	7.0		7.0	7.0
Flash Dont Walk (s)		17.0	17.0		18.0	18.0		17.0	17.0		18.0	18.0
Pedestrian Calls (#/hr)		2	2		2	2		2	2		2	2
Act Effct Green (s)	8.2	56.4	56.4	21.4	69.6	69.6	6.2	24.4	24.4	21.4	44.6	44.6
Actuated g/C Ratio	0.05	0.38	0.38	0.14	0.46	0.46	0.04	0.16	0.16	0.14	0.30	0.30

Lanes, Volumes, Timings 2175 Prince of Wales - 2030 PM - background only not optimized
 3: Prince of Wales Drive & West Hunt Club Road/Hunt Club Road 03/01/2024



Lane Group	EBL	EBT	EBR	WBL	WBT	WBR	NBL	NBT	NBR	SBL	SBT	SBR
v/c Ratio	0.59	0.90	0.08	1.33	0.84	0.41	0.42	0.86	1.68	1.02	0.83	0.22
Control Delay	83.1	54.8	0.2	210.8	41.9	3.6	88.0	77.9	342.7	108.9	58.2	2.2
Queue Delay	0.0	0.0	0.0	0.0	0.0	0.0	0.0	0.0	0.0	0.0	0.0	0.0
Total Delay	83.1	54.8	0.2	210.8	41.9	3.6	88.0	77.9	342.7	108.9	58.2	2.2
LOS	F	D	A	F	D	A	F	E	F	F	E	A
Approach Delay		54.7			83.1			239.1			70.1	
Approach LOS		D			F			F			E	
Queue Length 50th (m)	14.8	149.9	0.0	~115.1	159.7	0.0	8.2	66.3	~256.0	~68.8	117.5	0.0
Queue Length 95th (m)	24.3	#179.1	0.0	#149.9	188.8	15.8	18.7	#91.5	#327.4	#100.7	#153.4	3.5
Internal Link Dist (m)		163.8			255.7			73.7			181.8	
Turn Bay Length (m)	125.0		150.0	150.0		100.0	50.0			125.0		200.0
Base Capacity (vph)	184	1234	747	473	1509	869	73	539	457	455	995	545
Starvation Cap Reductn	0	0	0	0	0	0	0	0	0	0	0	0
Spillback Cap Reductn	0	0	0	0	0	0	0	0	0	0	0	0
Storage Cap Reductn	0	0	0	0	0	0	0	0	0	0	0	0
Reduced v/c Ratio	0.58	0.90	0.08	1.33	0.84	0.41	0.41	0.86	1.68	1.02	0.83	0.22

Intersection Summary

Area Type: Other
 Cycle Length: 150
 Actuated Cycle Length: 150
 Offset: 31 (21%), Referenced to phase 2:EBT and 6:WBT, Start of Green
 Natural Cycle: 150
 Control Type: Actuated-Coordinated
 Maximum v/c Ratio: 1.68
 Intersection Signal Delay: 106.1 Intersection LOS: F
 Intersection Capacity Utilization 113.3% ICU Level of Service H
 Analysis Period (min) 15
 ~ Volume exceeds capacity, queue is theoretically infinite.
 Queue shown is maximum after two cycles.
 # 95th percentile volume exceeds capacity, queue may be longer.
 Queue shown is maximum after two cycles.

Splits and Phases: 3: Prince of Wales Drive & West Hunt Club Road/Hunt Club Road

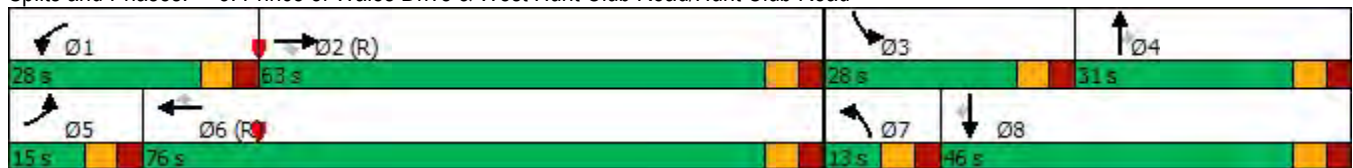

Lanes, Volumes, Timings 2175 Prince of Wales - 2030 PM - background only not optimized
 7: Prince of Wales Drive & Deakin Street 03/01/2024

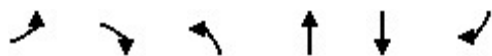

Lane Group	EBL	EBR	NBL	NBT	SBT	SBR
Lane Configurations						
Traffic Volume (vph)	476	191	35	794	1343	176
Future Volume (vph)	476	191	35	794	1343	176
Ideal Flow (vphpl)	1800	1800	1800	1800	1800	1800
Storage Length (m)	70.0	0.0	100.0			0.0
Storage Lanes	1	0	1			0
Taper Length (m)	7.6		7.6			
Lane Util. Factor	0.97	0.95	1.00	0.95	0.95	0.95
Ped Bike Factor	0.95				0.99	
Fr _t	0.957				0.983	
Fl _t Protected	0.966		0.950			
Satd. Flow (prot)	3122	0	1729	3390	3317	0
Fl _t Permitted	0.966		0.118			
Satd. Flow (perm)	3033	0	215	3390	3317	0
Right Turn on Red		Yes				Yes
Satd. Flow (RTOR)	48				26	
Link Speed (k/h)	50			60	60	
Link Distance (m)	195.1			117.9	111.9	
Travel Time (s)	14.0			7.1	6.7	
Confl. Peds. (#/hr)	20	20	20			20
Peak Hour Factor	1.00	1.00	1.00	1.00	1.00	1.00
Heavy Vehicles (%)	2%	2%	0%	2%	1%	5%
Adj. Flow (vph)	476	191	35	794	1343	176
Shared Lane Traffic (%)						
Lane Group Flow (vph)	667	0	35	794	1519	0
Turn Type	Prot		Perm	NA	NA	
Protected Phases	4			2	6	
Permitted Phases			2			
Detector Phase	4		2	2	6	
Switch Phase						
Minimum Initial (s)	5.0		5.0	5.0	5.0	
Minimum Split (s)	24.6		24.4	24.4	24.4	
Total Split (s)	33.0		87.0	87.0	87.0	
Total Split (%)	27.5%		72.5%	72.5%	72.5%	
Maximum Green (s)	26.4		80.6	80.6	80.6	
Yellow Time (s)	3.3		3.7	3.7	3.7	
All-Red Time (s)	3.3		2.7	2.7	2.7	
Lost Time Adjust (s)	0.0		0.0	0.0	0.0	
Total Lost Time (s)	6.6		6.4	6.4	6.4	
Lead/Lag						
Lead-Lag Optimize?						
Vehicle Extension (s)	3.0		3.0	3.0	3.0	
Recall Mode	None		C-Max	C-Max	C-Max	
Walk Time (s)	7.0		7.0	7.0	7.0	
Flash Dont Walk (s)	11.0		11.0	11.0	11.0	
Pedestrian Calls (#/hr)	0		0	0	0	
Act Effct Green (s)	25.9		81.1	81.1	81.1	
Actuated g/C Ratio	0.22		0.68	0.68	0.68	
v/c Ratio	0.94		0.24	0.35	0.68	

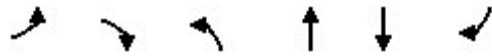

Lane Group	EBL	EBR	NBL	NBT	SBT	SBR
Control Delay	64.6		12.8	8.8	13.4	
Queue Delay	0.0		0.0	0.0	0.0	
Total Delay	64.6		12.8	8.8	13.4	
LOS	E		B	A	B	
Approach Delay	64.6			9.0	13.4	
Approach LOS	E			A	B	
Queue Length 50th (m)	68.8		2.7	35.4	94.0	
Queue Length 95th (m)	#100.0		8.1	44.6	114.7	
Internal Link Dist (m)	171.1			93.9	87.9	
Turn Bay Length (m)	70.0		100.0			
Base Capacity (vph)	724		145	2290	2249	
Starvation Cap Reductn	0		0	0	0	
Spillback Cap Reductn	0		0	0	0	
Storage Cap Reductn	0		0	0	0	
Reduced v/c Ratio	0.92		0.24	0.35	0.68	

Intersection Summary

Area Type: Other
 Cycle Length: 120
 Actuated Cycle Length: 120
 Offset: 0 (0%), Referenced to phase 2:NBT and 6:SBT, Start of Green
 Natural Cycle: 60
 Control Type: Actuated-Coordinated
 Maximum v/c Ratio: 0.94
 Intersection Signal Delay: 23.5 Intersection LOS: C
 Intersection Capacity Utilization 77.4% ICU Level of Service D
 Analysis Period (min) 15
 # 95th percentile volume exceeds capacity, queue may be longer.
 Queue shown is maximum after two cycles.

Splits and Phases: 7: Prince of Wales Drive & Deakin Street

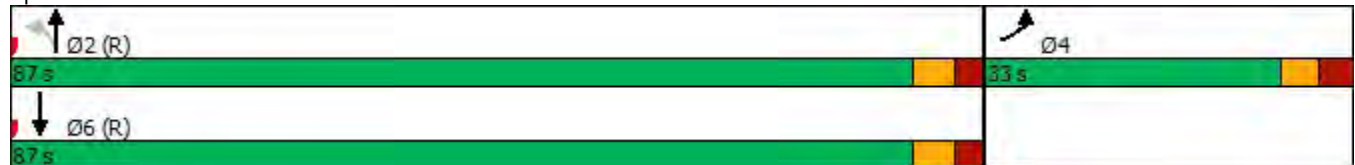

Intersection						
Int Delay, s/veh	0.3					
Movement	EBL	EBR	NBL	NBT	SBT	SBR
Lane Configurations		↗	↘	↑↑↑	↑↑↑	
Traffic Vol, veh/h	0	36	6	1265	1482	32
Future Vol, veh/h	0	36	6	1265	1482	32
Conflicting Peds, #/hr	20	20	20	0	0	20
Sign Control	Stop	Stop	Free	Free	Free	Free
RT Channelized	-	None	-	None	-	None
Storage Length	-	0	50	-	-	-
Veh in Median Storage, #	0	-	-	0	0	-
Grade, %	0	-	-	0	0	-
Peak Hour Factor	90	90	90	90	90	90
Heavy Vehicles, %	2	2	2	2	2	2
Mvmt Flow	0	40	7	1406	1647	36

Major/Minor	Minor2	Major1	Major2		
Conflicting Flow All	-	882	1703	0	-
Stage 1	-	-	-	-	-
Stage 2	-	-	-	-	-
Critical Hdwy	-	7.14	5.34	-	-
Critical Hdwy Stg 1	-	-	-	-	-
Critical Hdwy Stg 2	-	-	-	-	-
Follow-up Hdwy	-	3.92	3.12	-	-
Pot Cap-1 Maneuver	0	248	177	-	-
Stage 1	0	-	-	-	-
Stage 2	0	-	-	-	-
Platoon blocked, %				-	-
Mov Cap-1 Maneuver	-	237	172	-	-
Mov Cap-2 Maneuver	-	-	-	-	-
Stage 1	-	-	-	-	-
Stage 2	-	-	-	-	-

Approach	EB	NB	SB
HCM Control Delay, s	23.2	0.1	0
HCM LOS	C		

Minor Lane/Major Mvmt	NBL	NBT	EBLn1	SBT	SBR
Capacity (veh/h)	172	-	237	-	-
HCM Lane V/C Ratio	0.039	-	0.169	-	-
HCM Control Delay (s)	26.8	-	23.2	-	-
HCM Lane LOS	D	-	C	-	-
HCM 95th %tile Q(veh)	0.1	-	0.6	-	-

APPENDIX “F”

**TDM SUPPORTIVE DEVELOPMENT DESIGN AND INFRASTRUCTURE
CHECKLIST**

TDM-Supportive Development Design and Infrastructure Checklist:
Non-Residential Developments (office, institutional, retail or industrial)

Legend	
REQUIRED	The Official Plan or Zoning By-law provides related guidance that must be followed
BASIC	The measure is generally feasible and effective, and in most cases would benefit the development and its users
BETTER	The measure could maximize support for users of sustainable modes, and optimize development performance

TDM-supportive design & infrastructure measures: <i>Non-residential developments</i>		Check if completed & add descriptions, explanations or plan/drawing references
1. WALKING & CYCLING: ROUTES		
1.1 Building location & access points		
BASIC	1.1.1 Locate building close to the street, and do not locate parking areas between the street and building entrances	<input type="checkbox"/> The checklist is to be completed
BASIC	1.1.2 Locate building entrances in order to minimize walking distances to sidewalks and transit stops/stations	<input type="checkbox"/> at site plan stage
BASIC	1.1.3 Locate building doors and windows to ensure visibility of pedestrians from the building, for their security and comfort	<input type="checkbox"/>
1.2 Facilities for walking & cycling		
REQUIRED	1.2.1 Provide convenient, direct access to stations or major stops along rapid transit routes within 600 metres; minimize walking distances from buildings to rapid transit; provide pedestrian-friendly, weather-protected (where possible) environment between rapid transit accesses and building entrances; ensure quality linkages from sidewalks through building entrances to integrated stops/stations <i>(see Official Plan policy 4.3.3)</i>	<input type="checkbox"/>
REQUIRED	1.2.2 Provide safe, direct and attractive pedestrian access from public sidewalks to building entrances through such measures as: reducing distances between public sidewalks and major building entrances; providing walkways from public streets to major building entrances; within a site, providing walkways along the front of adjoining buildings, between adjacent buildings, and connecting areas where people may congregate, such as courtyards and transit stops; and providing weather protection through canopies, colonnades, and other design elements wherever possible <i>(see Official Plan policy 4.3.12)</i>	<input type="checkbox"/>

TDM-supportive design & infrastructure measures: <i>Non-residential developments</i>		Check if completed & add descriptions, explanations or plan/drawing references
REQUIRED	1.2.3 Provide sidewalks of smooth, well-drained walking surfaces of contrasting materials or treatments to differentiate pedestrian areas from vehicle areas, and provide marked pedestrian crosswalks at intersection sidewalks (<i>see Official Plan policy 4.3.10</i>)	<input type="checkbox"/>
REQUIRED	1.2.4 Make sidewalks and open space areas easily accessible through features such as gradual grade transition, depressed curbs at street corners and convenient access to extra-wide parking spaces and ramps (<i>see Official Plan policy 4.3.10</i>)	<input type="checkbox"/>
REQUIRED	1.2.5 Include adequately spaced inter-block/street cycling and pedestrian connections to facilitate travel by active transportation. Provide links to the existing or planned network of public sidewalks, multi-use pathways and on-road cycle routes. Where public sidewalks and multi-use pathways intersect with roads, consider providing traffic control devices to give priority to cyclists and pedestrians (<i>see Official Plan policy 4.3.11</i>)	<input type="checkbox"/>
BASIC	1.2.6 Provide safe, direct and attractive walking routes from building entrances to nearby transit stops	<input type="checkbox"/>
BASIC	1.2.7 Ensure that walking routes to transit stops are secure, visible, lighted, shaded and wind-protected wherever possible	<input type="checkbox"/>
BASIC	1.2.8 Design roads used for access or circulation by cyclists using a target operating speed of no more than 30 km/h, or provide a separated cycling facility	<input type="checkbox"/>
1.3 Amenities for walking & cycling		
BASIC	1.3.1 Provide lighting, landscaping and benches along walking and cycling routes between building entrances and streets, sidewalks and trails	<input type="checkbox"/>
BASIC	1.3.2 Provide wayfinding signage for site access (where required, e.g. when multiple buildings or entrances exist) and egress (where warranted, such as when directions to reach transit stops/stations, trails or other common destinations are not obvious)	<input type="checkbox"/>

TDM-supportive design & infrastructure measures: <i>Non-residential developments</i>		Check if completed & add descriptions, explanations or plan/drawing references
2. WALKING & CYCLING: END-OF-TRIP FACILITIES		
2.1 Bicycle parking		
REQUIRED	2.1.1 Provide bicycle parking in highly visible and lighted areas, sheltered from the weather wherever possible (see <i>Official Plan policy 4.3.6</i>)	<input type="checkbox"/>
REQUIRED	2.1.2 Provide the number of bicycle parking spaces specified for various land uses in different parts of Ottawa; provide convenient access to main entrances or well-used areas (see <i>Zoning By-law Section 111</i>)	<input type="checkbox"/>
REQUIRED	2.1.3 Ensure that bicycle parking spaces and access aisles meet minimum dimensions; that no more than 50% of spaces are vertical spaces; and that parking racks are securely anchored (see <i>Zoning By-law Section 111</i>)	<input type="checkbox"/>
BASIC	2.1.4 Provide bicycle parking spaces equivalent to the expected number of commuter cyclists (assuming the cycling mode share target is met), plus the expected peak number of customer/visitor cyclists	<input type="checkbox"/>
BETTER	2.1.5 Provide bicycle parking spaces equivalent to the expected number of commuter and customer/visitor cyclists, plus an additional buffer (e.g. 25 percent extra) to encourage other cyclists and ensure adequate capacity in peak cycling season	<input type="checkbox"/>
2.2 Secure bicycle parking		
REQUIRED	2.2.1 Where more than 50 bicycle parking spaces are provided for a single office building, locate at least 25% of spaces within a building/structure, a secure area (e.g. supervised parking lot or enclosure) or bicycle lockers (see <i>Zoning By-law Section 111</i>)	<input type="checkbox"/>
BETTER	2.2.2 Provide secure bicycle parking spaces equivalent to the expected number of commuter cyclists (assuming the cycling mode share target is met)	<input type="checkbox"/>
2.3 Shower & change facilities		
BASIC	2.3.1 Provide shower and change facilities for the use of active commuters	<input type="checkbox"/>
BETTER	2.3.2 In addition to shower and change facilities, provide dedicated lockers, grooming stations, drying racks and laundry facilities for the use of active commuters	<input type="checkbox"/>
2.4 Bicycle repair station		
BETTER	2.4.1 Provide a permanent bike repair station, with commonly used tools and an air pump, adjacent to the main bicycle parking area (or secure bicycle parking area, if provided)	<input type="checkbox"/>

TDM-supportive design & infrastructure measures: <i>Non-residential developments</i>		Check if completed & add descriptions, explanations or plan/drawing references
3. TRANSIT		
3.1 Customer amenities		
BASIC	3.1.1 Provide shelters, lighting and benches at any on-site transit stops	<input type="checkbox"/>
BASIC	3.1.2 Where the site abuts an off-site transit stop and insufficient space exists for a transit shelter in the public right-of-way, protect land for a shelter and/or install a shelter	<input type="checkbox"/>
BETTER	3.1.3 Provide a secure and comfortable interior waiting area by integrating any on-site transit stops into the building	<input type="checkbox"/>
4. RIDESHARING		
4.1 Pick-up & drop-off facilities		
BASIC	4.1.1 Provide a designated area for carpool drivers (plus taxis and ride-hailing services) to drop off or pick up passengers without using fire lanes or other no-stopping zones	<input type="checkbox"/>
4.2 Carpool parking		
BASIC	4.2.1 Provide signed parking spaces for carpools in a priority location close to a major building entrance, sufficient in number to accommodate the mode share target for carpools	<input type="checkbox"/>
BETTER	4.2.2 At large developments, provide spaces for carpools in a separate, access-controlled parking area to simplify enforcement	<input type="checkbox"/>
5. CARSHARING & BIKESHARING		
5.1 Carshare parking spaces		
BETTER	5.1.1 Provide carshare parking spaces in permitted non-residential zones, occupying either required or provided parking spaces (<i>see Zoning By-law Section 94</i>)	<input type="checkbox"/>
5.2 Bikeshare station location		
BETTER	5.2.1 Provide a designated bikeshare station area near a major building entrance, preferably lighted and sheltered with a direct walkway connection	<input type="checkbox"/>

TDM-supportive design & infrastructure measures: <i>Non-residential developments</i>		Check if completed & add descriptions, explanations or plan/drawing references
6. PARKING		
6.1 Number of parking spaces		
REQUIRED	6.1.1 Do not provide more parking than permitted by zoning, nor less than required by zoning, unless a variance is being applied for	<input type="checkbox"/>
BASIC	6.1.2 Provide parking for long-term and short-term users that is consistent with mode share targets, considering the potential for visitors to use off-site public parking	<input type="checkbox"/>
BASIC	6.1.3 Where a site features more than one use, provide shared parking and reduce the cumulative number of parking spaces accordingly (<i>see Zoning By-law Section 104</i>)	<input type="checkbox"/>
BETTER	6.1.4 Reduce the minimum number of parking spaces required by zoning by one space for each 13 square metres of gross floor area provided as shower rooms, change rooms, locker rooms and other facilities for cyclists in conjunction with bicycle parking (<i>see Zoning By-law Section 111</i>)	<input type="checkbox"/>
6.2 Separate long-term & short-term parking areas		
BETTER	6.2.1 Separate short-term and long-term parking areas using signage or physical barriers, to permit access controls and simplify enforcement (i.e. to discourage employees from parking in visitor spaces, and vice versa)	<input type="checkbox"/>
7. OTHER		
7.1 On-site amenities to minimize off-site trips		
BETTER	7.1.1 Provide on-site amenities to minimize mid-day or mid-commute errands	<input type="checkbox"/>

APPENDIX “G”

TURNING MOVEMENT ANALYSIS AT THE PROPOSED ACCESS

CITY OF OTTAWA
PRINCE OF WALES - MYERS SITE

PROPOSED ROADWAY MODIFICATIONS TO
ACCOMMODATE MYERS SITE



PROJECT REF. NUMBER: 7327

Contract No. 7327 Dwg. No. 01

Sheet 1 of 1

Asset Group

Des. AP Chk'd. AEG

Dwn. AP Chk'd. AEG

Utility Circ. No. Index No.

Cost. Inspector

Scale:

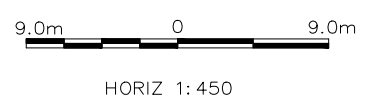

NOTE: The location of utilities is approximate only, the exact location should be determined by consulting the municipal authorities and utility companies concerned. The contractor shall prove the location of utilities and shall be responsible for adequate protection from damage.

No.	Description	By	Date (dd/mm/yy)
1	AS SUBMITTED TO CITY FOR COMMENT	AP	15/12/23
2	AS SUBMITTED TO CITY FOR COMMENT	AP	11/03/24
3	AS SUBMITTED TO CITY FOR COMMENT	AP	24/04/24

NOTES

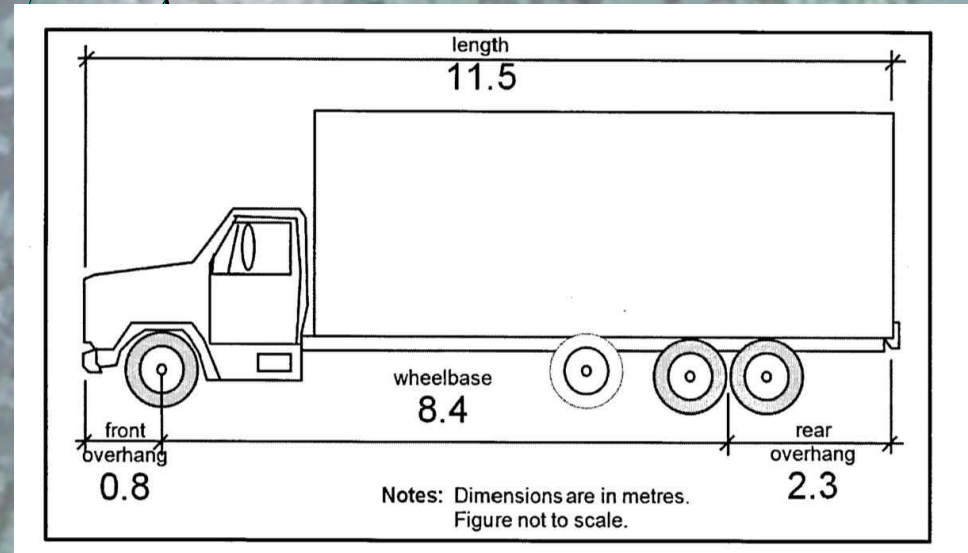
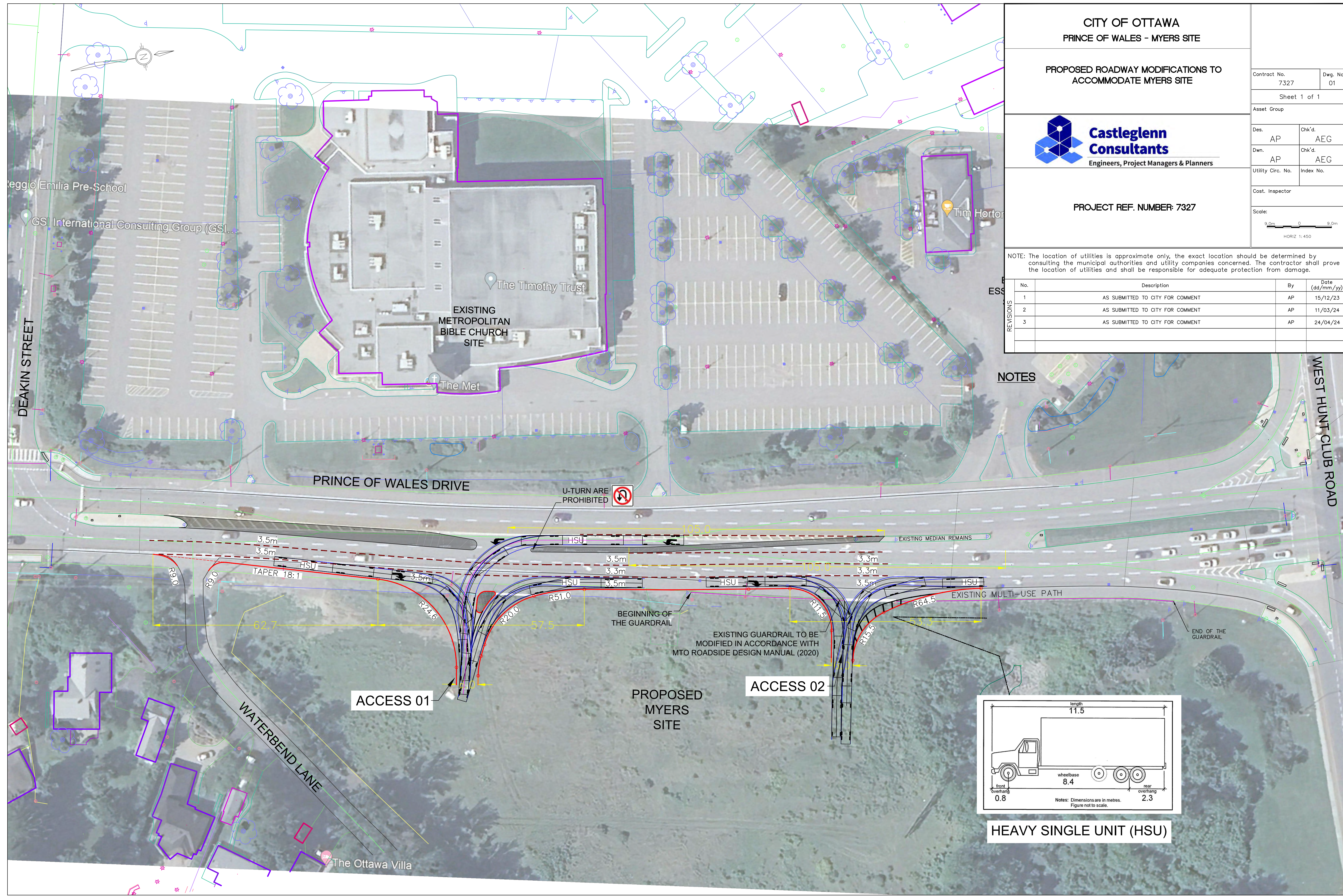

HEAVY SINGLE UNIT (HSU)

Notes: Dimensions are in metres. Figure not to scale.

CITY OF OTTAWA
PRINCE OF WALES - MYERS SITE

PROPOSED ROADWAY MODIFICATIONS TO
ACCOMMODATE MYERS SITE



PROJECT REF. NUMBER: 7327

Contract No. 7327 Dwg. No. 01

Sheet 1 of 1

Asset Group

Des. AP Chk'd. AEG

Dwn. AP Chk'd. AEG

Utility Circ. No. Index No.

Cost. Inspector

Scale:

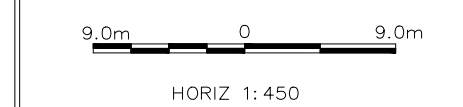

NOTE: The location of utilities is approximate only, the exact location should be determined by consulting the municipal authorities and utility companies concerned. The contractor shall prove the location of utilities and shall be responsible for adequate protection from damage.

No.	Description	By	Date (dd/mm/yy)
1	AS SUBMITTED TO CITY FOR COMMENT	AP	15/12/23
2	AS SUBMITTED TO CITY FOR COMMENT	AP	11/03/24
3	AS SUBMITTED TO CITY FOR COMMENT	AP	24/04/24

NOTES

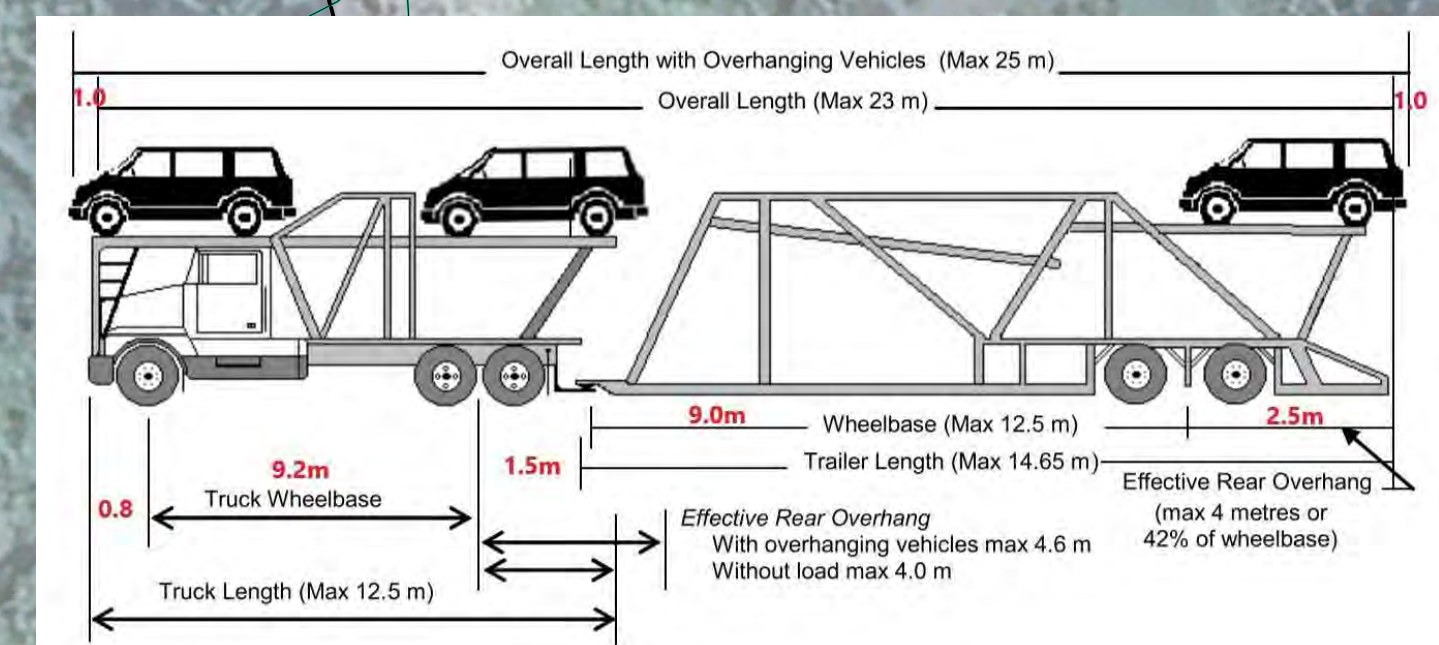
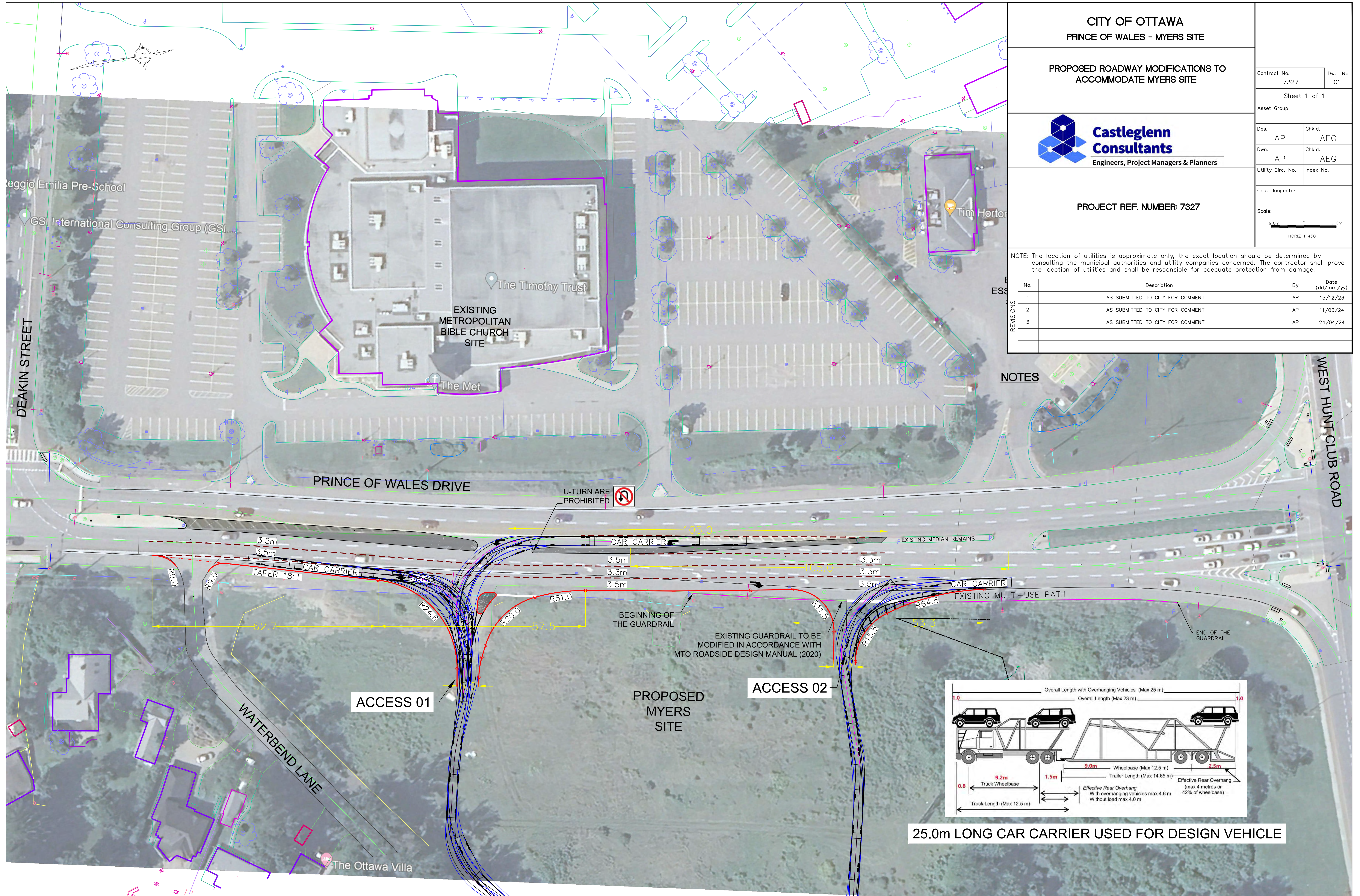

25.0m LONG CAR CARRIER USED FOR DESIGN VEHICLE

APPENDIX “H”

TDM MEASURES CHECKLIST

TDM Measures Checklist:
Non-Residential Developments (office, institutional, retail or industrial)

Legend

BASIC	The measure is generally feasible and effective, and in most cases would benefit the development and its users
BETTER	The measure could maximize support for users of sustainable modes, and optimize development performance
★	The measure is one of the most dependably effective tools to encourage the use of sustainable modes

TDM measures: <i>Non-residential developments</i>		Check if proposed & add descriptions
1. TDM PROGRAM MANAGEMENT		
1.1 Program coordinator		
BASIC	★ 1.1.1 Designate an internal coordinator, or contract with an external coordinator	<input checked="" type="checkbox"/> Basic TDM Measures are recommended.
1.2 Travel surveys		
BETTER	1.2.1 Conduct periodic surveys to identify travel-related behaviours, attitudes, challenges and solutions, and to track progress	<input type="checkbox"/> Further review needed upon site plan stage
2. WALKING AND CYCLING		
2.1 Information on walking/cycling routes & destinations		
BASIC	2.1.1 Display local area maps with walking/cycling access routes and key destinations at major entrances	<input checked="" type="checkbox"/>
2.2 Bicycle skills training		
<i>Commuter travel</i>		
BETTER	★ 2.2.1 Offer on-site cycling courses for commuters, or subsidize off-site courses	<input type="checkbox"/>
2.3 Valet bike parking		
<i>Visitor travel</i>		
BETTER	2.3.1 Offer secure valet bike parking during public events when demand exceeds fixed supply (e.g. for festivals, concerts, games)	<input type="checkbox"/>

TDM measures: <i>Non-residential developments</i>		Check if proposed & add descriptions
3. TRANSIT		
3.1 Transit information		
BASIC	3.1.1 Display relevant transit schedules and route maps at entrances	<input checked="" type="checkbox"/>
BASIC	3.1.2 Provide online links to OC Transpo and STO information	<input checked="" type="checkbox"/>
BETTER	3.1.3 Provide real-time arrival information display at entrances	<input type="checkbox"/>
3.2 Transit fare incentives		
<i>Commuter travel</i>		
BETTER	3.2.1 Offer preloaded PRESTO cards to encourage commuters to use transit	<input type="checkbox"/>
BETTER ★	3.2.2 Subsidize or reimburse monthly transit pass purchases by employees	<input type="checkbox"/>
<i>Visitor travel</i>		
BETTER	3.2.3 Arrange inclusion of same-day transit fare in price of tickets (e.g. for festivals, concerts, games)	<input type="checkbox"/>
3.3 Enhanced public transit service		
<i>Commuter travel</i>		
BETTER	3.3.1 Contract with OC Transpo to provide enhanced transit services (e.g. for shift changes, weekends)	<input type="checkbox"/>
<i>Visitor travel</i>		
BETTER	3.3.2 Contract with OC Transpo to provide enhanced transit services (e.g. for festivals, concerts, games)	<input type="checkbox"/>
3.4 Private transit service		
<i>Commuter travel</i>		
BETTER	3.4.1 Provide shuttle service when OC Transpo cannot offer sufficient quality or capacity to serve demand (e.g. for shift changes, weekends)	<input type="checkbox"/>
<i>Visitor travel</i>		
BETTER	3.4.2 Provide shuttle service when OC Transpo cannot offer sufficient quality or capacity to serve demand (e.g. for festivals, concerts, games)	<input type="checkbox"/>

TDM measures: <i>Non-residential developments</i>		Check if proposed & add descriptions
4. RIDESHARING		
4.1 Ridematching service		
<i>Commuter travel</i>		
BASIC	★ 4.1.1 Provide a dedicated ridematching portal at OttawaRideMatch.com	<input checked="" type="checkbox"/> or similar
4.2 Carpool parking price incentives		
<i>Commuter travel</i>		
BETTER	4.2.1 Provide discounts on parking costs for registered carpools	<input type="checkbox"/>
4.3 Vanpool service		
<i>Commuter travel</i>		
BETTER	4.3.1 Provide a vanpooling service for long-distance commuters	<input type="checkbox"/>
5. CARSHARING & BIKESHARING		
5.1 Bikeshare stations & memberships		
BETTER	5.1.1 Contract with provider to install on-site bikeshare station for use by commuters and visitors	<input type="checkbox"/>
<i>Commuter travel</i>		
BETTER	5.1.2 Provide employees with bikeshare memberships for local business travel	<input type="checkbox"/>
5.2 Carshare vehicles & memberships		
<i>Commuter travel</i>		
BETTER	5.2.1 Contract with provider to install on-site carshare vehicles and promote their use by tenants	<input type="checkbox"/>
BETTER	5.2.2 Provide employees with carshare memberships for local business travel	<input type="checkbox"/>
6. PARKING		
6.1 Priced parking		
<i>Commuter travel</i>		
BASIC	★ 6.1.1 Charge for long-term parking (daily, weekly, monthly)	<input type="checkbox"/> not applicable
BASIC	6.1.2 Unbundle parking cost from lease rates at multi-tenant sites	<input type="checkbox"/> not applicable
<i>Visitor travel</i>		
BETTER	6.1.3 Charge for short-term parking (hourly)	<input type="checkbox"/>

TDM measures: <i>Non-residential developments</i>		Check if proposed & add descriptions
7. TDM MARKETING & COMMUNICATIONS		
7.1 Multimodal travel information		
<i>Commuter travel</i>		
BASIC ★	7.1.1 Provide a multimodal travel option information package to new/relocating employees and students	<input checked="" type="checkbox"/>
<i>Visitor travel</i>		
BETTER ★	7.1.2 Include multimodal travel option information in invitations or advertising that attract visitors or customers (e.g. for festivals, concerts, games)	<input type="checkbox"/>
7.2 Personalized trip planning		
<i>Commuter travel</i>		
BETTER ★	7.2.1 Offer personalized trip planning to new/relocating employees	<input type="checkbox"/>
7.3 Promotions		
<i>Commuter travel</i>		
BETTER	7.3.1 Deliver promotions and incentives to maintain awareness, build understanding, and encourage trial of sustainable modes	<input type="checkbox"/>
8. OTHER INCENTIVES & AMENITIES		
8.1 Emergency ride home		
<i>Commuter travel</i>		
BETTER ★	8.1.1 Provide emergency ride home service to non-driving commuters	<input type="checkbox"/>
8.2 Alternative work arrangements		
<i>Commuter travel</i>		
BASIC ★	8.2.1 Encourage flexible work hours	<input checked="" type="checkbox"/> if applicable
BETTER	8.2.2 Encourage compressed workweeks	<input type="checkbox"/>
BETTER ★	8.2.3 Encourage telework	<input type="checkbox"/>
8.3 Local business travel options		
<i>Commuter travel</i>		
BASIC ★	8.3.1 Provide local business travel options that minimize the need for employees to bring a personal car to work	<input checked="" type="checkbox"/> if applicable
8.4 Commuter incentives		
<i>Commuter travel</i>		
BETTER	8.4.1 Offer employees a taxable, mode-neutral commuting allowance	<input type="checkbox"/>
8.5 On-site amenities		
<i>Commuter travel</i>		
BETTER	8.5.1 Provide on-site amenities/services to minimize mid-day or mid-commute errands	<input type="checkbox"/>

APPENDIX “I”

INTERSECTION MMLOS ANALYSIS SHEETS

Performance Measure	Intersection Leg			
	East Leg - Hunt Club Road	West Leg - Hunt Club Road	North Leg - Prince of Wales Drive	South Leg - Prince of Wales Drive
<i>Pedestrian LOS (PLOS)</i>				
Total Travel Lanes	9	9	9	9
Median > 2.4m	No	No	No	No
Island Refuge	No	No	No	No
Left Turn Type	Protected	Protected	Protected	Protected
Right Turn Type	Permissive	Permissive	Permissive	Permissive
Right Turns on Red	Allowed	Allowed	Allowed	Allowed
Leading Pedestrian Interval	No	No	No	No
Corner Radius	15 to 25 m	15 to 25 m	15 to 25 m	15 to 25 m
Right Turn Channel	Without Receiving lane	Without Receiving lane	Without Receiving lane	Without Receiving lane
Crosswalk Treatment	Standard Transverse	Standard Transverse	Standard Transverse	Standard Transverse
PETSI Points	-19	-19	-19	-19
Intersection PLOS	F	F	F	F
Target PLOS	C	C	C	C
<i>Bicycle LOS (BLOS)</i>				
Bikeway Type	Bike Lane	Bike Lane	Bike Lane	Bike Lane
Left Turn Lane Configuration of Approach	Two-stage, left turn bike box	Two-stage, left turn bike box	Two-stage, left turn bike box	Two-stage, left turn bike box
Right Turn Lane Configuration of Approach	N/A	N/A	N/A	N/A
Length of Right Turn Lane	N/A	N/A	N/A	N/A
Turning Speed of Right Turning Vehicles	N/A	N/A	N/A	N/A
Operating Speed (km/h)	90	90	70	70
Intersection BLOS	C	C	C	C
Target BLOS	C	C	B	B
<i>Transit LOS (TLOS)</i>				
Delay (2030 Development + Background)	>50 sec	>50 sec	>50 sec	>50 sec
Intersection TLOS	F	F	F	F
Target TLOS	D	D	D	D
<i>Truck LOS (TkLOS)</i>				
Effective Corner Radius (m)	>15 m	>15 m	>15 m	>15 m
Number of Receiving Lanes on Departing Leg	2	2	2	2
Intersection TkLOS	A	A	A	A
Target TkLOS	D	D	D	D

Performance Measure	Intersection Leg			
	East Leg - N/A	West Leg - Deakin Street	North Leg - Prince of Wales Drive	South Leg - Prince of Wales Drive
<i>Pedestrian LOS (PLOS)</i>				
Total Travel Lanes	N/A	6	N/A	8
Median > 2.4m	N/A	No	N/A	No
Island Refuge	N/A	No	N/A	No
Left Turn Type	N/A	Permissive	N/A	No LT
Right Turn Type	N/A	Permissive	N/A	Permissive
Right Turns on Red	N/A	Allowed	N/A	Allowed
Leading Pedestrian Interval	N/A	No	N/A	No
Corner Radius	N/A	10 to 15m	N/A	10 to 15m
Right Turn Channel	N/A	No Right Turn Channel (-4)	N/A	No Right turn (0)
Crosswalk Treatment	N/A	Zebra Stripe (-4)	N/A	Zebra Stripe (-4)
PETSI Points	N/A	23	N/A	-1
Intersection PLOS	N/A	F	N/A	F
Target PLOS	N/A	C	N/A	C
<i>Bicycle LOS (BLOS)</i>				
Bikeway Type	N/A	Bike Lane	Bike Lane	Bike Lane
Left Turn Lane Configuration of Approach	N/A	Two-stage, left turn bike box	No LT	Two-stage, left turn bike box
Right Turn Lane Configuration of Approach	N/A	N/A	N/A	N/A
Length of Right Turn Lane	N/A	N/A	N/A	N/A
Turning Speed of Right Turning Vehicles	N/A	N/A	N/A	N/A
Operating Speed (km/h)	N/A	60	70	70
Intersection BLOS	N/A	C	A	C
Target BLOS	N/A	B	B	B
<i>Transit LOS (TLOS)</i>				
Delay (2030 Development + Background)	N/A	>50 sec	<20 sec	<20 sec
Intersection TLOS	N/A	F	B	B
Target TLOS	N/A	D	D	D
<i>Truck LOS (TkLOS)</i>				
Effective Corner Radius (m)	N/A	10 to 15m	>15 m	N/A
Number of Receiving Lanes on Departing Leg	N/A	1	2	2
Intersection TkLOS	N/A	N/A	A	A
Target TkLOS	N/A	No Target	D	D

APPENDIX “J”

SYNCHRO ANALYSIS OUTPUT SHEETS TOTAL (2025 AND 2030)

J-1

AUTO DEALERSHIP (80,000 SQFT)

Lanes, Volumes, Timings

2175 Prince of Wales - 2025 AM - auto dealership 80000 sqft

3: Prince of Wales Drive & West Hunt Club Road/Hunt Club Road

02/29/2024



Lane Group	EBL	EBT	EBR	WBL	WBT	WBR	NBL	NBT	NBR	SBL	SBT	SBR
Lane Configurations	↕↕	↕↕	↕	↕↕	↕↕	↕	↕	↕↕	↕	↕↕	↕↕	↕
Traffic Volume (vph)	87	842	10	574	1106	450	81	743	946	284	448	210
Future Volume (vph)	87	842	10	574	1106	450	81	743	946	284	448	210
Ideal Flow (vphpl)	1800	1800	1800	1800	1800	1800	1800	1800	1800	1800	1800	1800
Lane Width (m)	3.7	3.5	4.8	3.7	3.5	3.7	3.7	3.5	4.8	3.7	3.5	3.5
Storage Length (m)	125.0		150.0	150.0		100.0	50.0		0.0	125.0		200.0
Storage Lanes	2		1	2		1	1		1	2		1
Taper Length (m)	7.6			7.6			7.6			7.6		
Lane Util. Factor	0.97	0.95	1.00	0.97	0.95	1.00	1.00	0.95	1.00	0.97	0.95	1.00
Ped Bike Factor	1.00		0.98	1.00		0.98	1.00		0.98	1.00		0.98
Fr't			0.850			0.850			0.850			0.850
Flt Protected	0.950			0.950			0.950			0.950		
Satd. Flow (prot)	3022	3161	1535	3225	3252	1488	1662	3349	1683	3195	3221	1427
Flt Permitted	0.950			0.950			0.950			0.950		
Satd. Flow (perm)	3020	3161	1511	3222	3252	1465	1659	3349	1658	3188	3221	1405
Right Turn on Red			Yes			Yes			Yes			Yes
Satd. Flow (RTOR)			182			272			248			202
Link Speed (k/h)		80			80			60				60
Link Distance (m)		187.8			279.7			97.7				205.8
Travel Time (s)		8.5			12.6			5.9				12.3
Confl. Peds. (#/hr)	2		2	2		2	2		2	2		2
Peak Hour Factor	1.00	1.00	1.00	1.00	1.00	1.00	1.00	1.00	1.00	1.00	1.00	1.00
Heavy Vehicles (%)	11%	7%	13%	4%	4%	4%	4%	1%	3%	5%	5%	6%
Adj. Flow (vph)	87	842	10	574	1106	450	81	743	946	284	448	210
Shared Lane Traffic (%)												
Lane Group Flow (vph)	87	842	10	574	1106	450	81	743	946	284	448	210
Turn Type	Prot	NA	Perm	Prot	NA	Perm	Prot	NA	Perm	Prot	NA	Perm
Protected Phases	5	2		1	6		7	4		3	8	
Permitted Phases			2			6			4			8
Detector Phase	5	2	2	1	6	6	7	4	4	3	8	8
Switch Phase												
Minimum Initial (s)	1.0	1.0	1.0	1.0	1.0	1.0	1.0	1.0	1.0	1.0	1.0	1.0
Minimum Split (s)	11.6	31.8	31.8	11.6	34.2	34.2	11.6	31.6	31.6	11.6	31.6	31.6
Total Split (s)	16.0	48.0	48.0	28.0	60.0	60.0	20.0	44.0	44.0	20.0	44.0	44.0
Total Split (%)	11.4%	34.3%	34.3%	20.0%	42.9%	42.9%	14.3%	31.4%	31.4%	14.3%	31.4%	31.4%
Maximum Green (s)	9.4	41.2	41.2	21.4	53.2	53.2	13.4	37.4	37.4	13.4	37.4	37.4
Yellow Time (s)	3.7	4.6	4.6	3.7	4.6	4.6	3.7	3.7	3.7	3.7	3.7	3.7
All-Red Time (s)	2.9	2.2	2.2	2.9	2.2	2.2	2.9	2.9	2.9	2.9	2.9	2.9
Lost Time Adjust (s)	0.0	0.0	0.0	0.0	0.0	0.0	0.0	0.0	0.0	0.0	0.0	0.0
Total Lost Time (s)	6.6	6.8	6.8	6.6	6.8	6.8	6.6	6.6	6.6	6.6	6.6	6.6
Lead/Lag	Lead	Lag	Lag	Lead	Lag	Lag	Lead	Lag	Lag	Lead	Lag	Lag
Lead-Lag Optimize?	Yes	Yes	Yes	Yes	Yes	Yes	Yes	Yes	Yes	Yes	Yes	Yes
Vehicle Extension (s)	3.0	3.0	3.0	3.0	3.0	3.0	3.0	3.0	3.0	3.0	3.0	3.0
Recall Mode	None	C-Max	C-Max	None	C-Max	C-Max	None	Max	Max	None	Max	Max
Walk Time (s)		7.0	7.0		7.0	7.0		7.0	7.0		7.0	7.0
Flash Dont Walk (s)		18.0	18.0		18.0	18.0		17.0	17.0		17.0	17.0
Pedestrian Calls (#/hr)		2	2		2	2		2	2		2	2
Act Effct Green (s)	8.6	41.2	41.2	21.4	54.0	54.0	11.3	37.4	37.4	13.4	39.5	39.5
Actuated g/C Ratio	0.06	0.29	0.29	0.15	0.39	0.39	0.08	0.27	0.27	0.10	0.28	0.28

Lanes, Volumes, Timings 2175 Prince of Wales - 2025 AM - auto dealership 80000 sqft
 3: Prince of Wales Drive & West Hunt Club Road/Hunt Club Road 02/29/2024

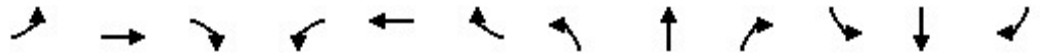

Lane Group	EBL	EBT	EBR	WBL	WBT	WBR	NBL	NBT	NBR	SBL	SBT	SBR
v/c Ratio	0.47	0.91	0.02	1.17	0.88	0.61	0.60	0.83	1.52	0.93	0.49	0.39
Control Delay	71.7	61.7	0.1	145.9	49.8	17.0	80.7	57.6	267.3	98.9	44.6	8.1
Queue Delay	0.0	0.0	0.0	0.0	0.0	0.0	0.0	0.0	0.0	0.0	0.0	0.0
Total Delay	71.7	61.7	0.1	145.9	49.8	17.0	80.7	57.6	267.3	98.9	44.6	8.1
LOS	E	E	A	F	D	B	F	E	F	F	D	A
Approach Delay		62.0			68.7			170.7			52.8	
Approach LOS		E			E			F			D	
Queue Length 50th (m)	11.1	109.0	0.0	~89.3	138.6	35.9	20.2	94.4	~288.3	37.6	50.7	1.5
Queue Length 95th (m)	19.5	#142.2	0.0	#122.8	#169.0	69.5	35.9	116.7	#361.8	#62.7	67.4	19.9
Internal Link Dist (m)		163.8			255.7			73.7			181.8	
Turn Bay Length (m)	125.0		150.0	150.0		100.0	50.0			125.0		200.0
Base Capacity (vph)	202	930	573	492	1253	732	159	894	624	305	909	541
Starvation Cap Reductn	0	0	0	0	0	0	0	0	0	0	0	0
Spillback Cap Reductn	0	0	0	0	0	0	0	0	0	0	0	0
Storage Cap Reductn	0	0	0	0	0	0	0	0	0	0	0	0
Reduced v/c Ratio	0.43	0.91	0.02	1.17	0.88	0.61	0.51	0.83	1.52	0.93	0.49	0.39

Intersection Summary

Area Type: Other
 Cycle Length: 140
 Actuated Cycle Length: 140
 Offset: 68 (49%), Referenced to phase 2:EBT and 6:WBT, Start of Green
 Natural Cycle: 150
 Control Type: Actuated-Coordinated
 Maximum v/c Ratio: 1.52
 Intersection Signal Delay: 96.3 Intersection LOS: F
 Intersection Capacity Utilization 111.8% ICU Level of Service H
 Analysis Period (min) 15
 ~ Volume exceeds capacity, queue is theoretically infinite.
 Queue shown is maximum after two cycles.
 # 95th percentile volume exceeds capacity, queue may be longer.
 Queue shown is maximum after two cycles.

Splits and Phases: 3: Prince of Wales Drive & West Hunt Club Road/Hunt Club Road





Lane Group	EBL	EBR	NBL	NBT	SBT	SBR
Lane Configurations						
Traffic Volume (vph)	518	22	158	1264	568	407
Future Volume (vph)	518	22	158	1264	568	407
Ideal Flow (vphpl)	1800	1800	1800	1800	1800	1800
Storage Length (m)	70.0	0.0	100.0			0.0
Storage Lanes	1	0	1			0
Taper Length (m)	7.6		7.6			
Lane Util. Factor	0.97	0.95	1.00	0.95	0.95	0.95
Ped Bike Factor	1.00		1.00		0.99	
Frt	0.994				0.937	
Flt Protected	0.954		0.950			
Satd. Flow (prot)	3279	0	1695	3390	3144	0
Flt Permitted	0.954		0.261			
Satd. Flow (perm)	3272	0	465	3390	3144	0
Right Turn on Red		Yes				Yes
Satd. Flow (RTOR)	4				324	
Link Speed (k/h)	50			60	60	
Link Distance (m)	195.1			117.9	111.9	
Travel Time (s)	14.0			7.1	6.7	
Confl. Peds. (#/hr)	2	2	2			2
Peak Hour Factor	1.00	1.00	1.00	1.00	1.00	1.00
Adj. Flow (vph)	518	22	158	1264	568	407
Shared Lane Traffic (%)						
Lane Group Flow (vph)	540	0	158	1264	975	0
Turn Type	Prot		Perm	NA	NA	
Protected Phases	4			2	6	
Permitted Phases			2			
Detector Phase	4		2	2	6	
Switch Phase						
Minimum Initial (s)	1.0		5.0	5.0	5.0	
Minimum Split (s)	33.6		29.4	29.4	29.4	
Total Split (s)	33.6		67.0	67.0	67.0	
Total Split (%)	33.4%		66.6%	66.6%	66.6%	
Maximum Green (s)	27.0		60.6	60.6	60.6	
Yellow Time (s)	3.3		3.7	3.7	3.7	
All-Red Time (s)	3.3		2.7	2.7	2.7	
Lost Time Adjust (s)	0.0		0.0	0.0	0.0	
Total Lost Time (s)	6.6		6.4	6.4	6.4	
Lead/Lag						
Lead-Lag Optimize?						
Vehicle Extension (s)	3.0		3.0	3.0	3.0	
Recall Mode	None		C-Max	C-Max	C-Max	
Walk Time (s)	7.0		7.0	7.0	7.0	
Flash Dont Walk (s)	20.0		16.0	16.0	16.0	
Pedestrian Calls (#/hr)	2		2	2	2	
Act Effct Green (s)	21.7		65.9	65.9	65.9	
Actuated g/C Ratio	0.22		0.66	0.66	0.66	
v/c Ratio	0.76		0.52	0.57	0.45	
Control Delay	44.0		18.0	11.4	6.4	



Lane Group	EBL	EBR	NBL	NBT	SBT	SBR
Queue Delay	0.0		0.0	0.0	0.0	
Total Delay	44.0		18.0	11.4	6.4	
LOS	D		B	B	A	
Approach Delay	44.0			12.1	6.4	
Approach LOS	D			B	A	
Queue Length 50th (m)	46.8		13.4	59.3	24.8	
Queue Length 95th (m)	59.0		37.1	88.6	42.5	
Internal Link Dist (m)	171.1			93.9	87.9	
Turn Bay Length (m)	70.0		100.0			
Base Capacity (vph)	882		304	2221	2172	
Starvation Cap Reductn	0		0	0	0	
Spillback Cap Reductn	0		0	0	0	
Storage Cap Reductn	0		0	0	0	
Reduced v/c Ratio	0.61		0.52	0.57	0.45	

Intersection Summary

Area Type:	Other
Cycle Length:	100.6
Actuated Cycle Length:	100.6
Offset:	0 (0%), Referenced to phase 2:NBTL and 6:SBT, Start of Green
Natural Cycle:	80
Control Type:	Actuated-Coordinated
Maximum v/c Ratio:	0.76
Intersection Signal Delay:	16.1
Intersection LOS:	B
Intersection Capacity Utilization	72.6%
ICU Level of Service	C
Analysis Period (min)	15

Splits and Phases: 7: Prince of Wales Drive & Deakin Street

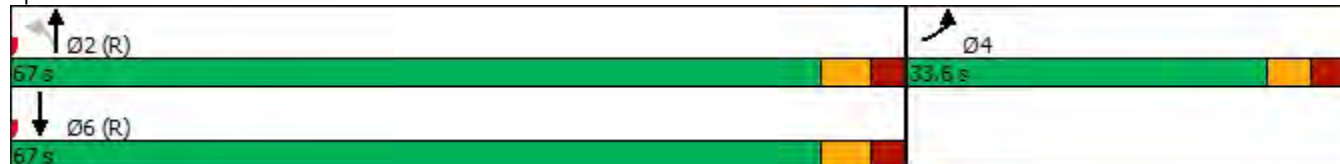

Intersection

Int Delay, s/veh 0.6

Movement EBL EBR NBL NBT SBT SBR

Lane Configurations		↗	↘	↑↑↑	↑↑↑	
Traffic Vol, veh/h	0	90	15	1771	958	84
Future Vol, veh/h	0	90	15	1771	958	84
Conflicting Peds, #/hr	20	20	20	0	0	20
Sign Control	Stop	Stop	Free	Free	Free	Free
RT Channelized	-	None	-	None	-	None
Storage Length	-	0	50	-	-	-
Veh in Median Storage, #	0	-	-	0	0	-
Grade, %	0	-	-	0	0	-
Peak Hour Factor	100	100	100	100	100	100
Heavy Vehicles, %	2	2	2	2	2	2
Mvmt Flow	0	90	15	1771	958	84

Major/Minor Minor2 Major1 Major2

Conflicting Flow All	-	561	1062	0	-	0
Stage 1	-	-	-	-	-	-
Stage 2	-	-	-	-	-	-
Critical Hdwy	-	7.14	5.34	-	-	-
Critical Hdwy Stg 1	-	-	-	-	-	-
Critical Hdwy Stg 2	-	-	-	-	-	-
Follow-up Hdwy	-	3.92	3.12	-	-	-
Pot Cap-1 Maneuver	0	403	365	-	-	-
Stage 1	0	-	-	-	-	-
Stage 2	0	-	-	-	-	-
Platoon blocked, %				-	-	-
Mov Cap-1 Maneuver	-	385	355	-	-	-
Mov Cap-2 Maneuver	-	-	-	-	-	-
Stage 1	-	-	-	-	-	-
Stage 2	-	-	-	-	-	-

Approach EB NB SB

HCM Control Delay, s 17.2 0.1 0
 HCM LOS C

Minor Lane/Major Mvmt NBL NBT EBLn1 SBT SBR

Capacity (veh/h)	355	-	385	-	-
HCM Lane V/C Ratio	0.042	-	0.234	-	-
HCM Control Delay (s)	15.6	-	17.2	-	-
HCM Lane LOS	C	-	C	-	-
HCM 95th %tile Q(veh)	0.1	-	0.9	-	-

Intersection

Int Delay, s/veh 1.3

Movement	WBL	WBR	NBT	NBR	SBL	SBT
Lane Configurations		↑↑↑	↑↑↑		↑	↑↑
Traffic Vol, veh/h	0	16	1761	22	73	976
Future Vol, veh/h	0	16	1761	22	73	976
Conflicting Peds, #/hr	0	0	0	0	0	0
Sign Control	Stop	Stop	Free	Free	Free	Free
RT Channelized	-	None	-	None	-	None
Storage Length	-	0	-	-	0	-
Veh in Median Storage, #	0	-	0	-	-	0
Grade, %	0	-	0	-	-	0
Peak Hour Factor	100	100	100	100	100	100
Heavy Vehicles, %	2	2	2	2	2	2
Mvmt Flow	0	16	1761	22	73	976

Major/Minor

	Minor1	Major1	Major2		
Conflicting Flow All	-	892	0	0	1783
Stage 1	-	-	-	-	-
Stage 2	-	-	-	-	-
Critical Hdwy	-	7.14	-	-	5.34
Critical Hdwy Stg 1	-	-	-	-	-
Critical Hdwy Stg 2	-	-	-	-	-
Follow-up Hdwy	-	3.92	-	-	3.12
Pot Cap-1 Maneuver	0	245	-	-	161
Stage 1	0	-	-	-	-
Stage 2	0	-	-	-	-
Platoon blocked, %					
Mov Cap-1 Maneuver	-	245	-	-	161
Mov Cap-2 Maneuver	-	-	-	-	-
Stage 1	-	-	-	-	-
Stage 2	-	-	-	-	-

Approach

	WB	NB	SB
HCM Control Delay, s	20.7	0	3.1
HCM LOS	C		

Minor Lane/Major Mvmt

	NBT	NBRWBLn1	SBL	SBT
Capacity (veh/h)	-	-	245	161
HCM Lane V/C Ratio	-	-	0.065	0.453
HCM Control Delay (s)	-	-	20.7	44.7
HCM Lane LOS	-	-	C	E
HCM 95th %tile Q(veh)	-	-	0.2	2.1

Intersection

Int Delay, s/veh 0.2

Movement	WBL	WBR	NBT	NBR	SBL	SBT
Lane Configurations		↑↑↑	↑↑↑			↑↑↑
Traffic Vol, veh/h	0	24	1762	15	0	1049
Future Vol, veh/h	0	24	1762	15	0	1049
Conflicting Peds, #/hr	0	0	0	0	0	0
Sign Control	Stop	Stop	Free	Free	Free	Free
RT Channelized	-	None	-	None	-	None
Storage Length	-	0	-	-	-	-
Veh in Median Storage, #	0	-	0	-	-	0
Grade, %	0	-	0	-	-	0
Peak Hour Factor	100	100	100	100	100	100
Heavy Vehicles, %	2	2	2	2	2	2
Mvmt Flow	0	24	1762	15	0	1049

Major/Minor	Minor1	Major1	Major2
Conflicting Flow All	-	889	0
Stage 1	-	-	-
Stage 2	-	-	-
Critical Hdwy	-	7.14	-
Critical Hdwy Stg 1	-	-	-
Critical Hdwy Stg 2	-	-	-
Follow-up Hdwy	-	3.92	-
Pot Cap-1 Maneuver	0	246	-
Stage 1	0	-	-
Stage 2	0	-	-
Platoon blocked, %			
Mov Cap-1 Maneuver	-	246	-
Mov Cap-2 Maneuver	-	-	-
Stage 1	-	-	-
Stage 2	-	-	-

Approach	WB	NB	SB
HCM Control Delay, s	21.2	0	0
HCM LOS	C		

Minor Lane/Major Mvmt	NBT	NBRWBLn1	SBT
Capacity (veh/h)	-	-	246
HCM Lane V/C Ratio	-	-	0.098
HCM Control Delay (s)	-	-	21.2
HCM Lane LOS	-	-	C
HCM 95th %tile Q(veh)	-	-	0.3

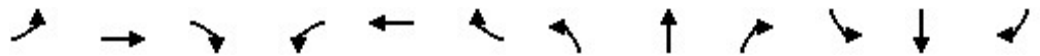

Lane Group	EBL	EBT	EBR	WBL	WBT	WBR	NBL	NBT	NBR	SBL	SBT	SBR
Lane Configurations	↖↗	↕	↖	↖↗	↕	↖	↖	↕	↖	↖↗	↕	↖
Traffic Volume (vph)	103	1082	59	637	1242	344	70	484	797	451	835	117
Future Volume (vph)	103	1082	59	637	1242	344	70	484	797	451	835	117
Ideal Flow (vphpl)	1800	1800	1800	1800	1800	1800	1800	1800	1800	1800	1800	1800
Lane Width (m)	3.7	3.5	4.8	3.7	3.5	3.7	3.7	3.5	4.8	3.7	3.5	3.5
Storage Length (m)	125.0		150.0	150.0		100.0	50.0		0.0	125.0		200.0
Storage Lanes	2		1	2		1	1		1	2		1
Taper Length (m)	7.6			7.6			7.6			7.6		
Lane Util. Factor	0.97	0.95	1.00	0.97	0.95	1.00	1.00	0.95	1.00	0.97	0.95	1.00
Ped Bike Factor	1.00		0.98	1.00		0.98	1.00		0.98	1.00		0.98
Fr't			0.850			0.850			0.850			0.850
Flt Protected	0.950			0.950			0.950			0.950		
Satd. Flow (prot)	3288	3283	1651	3321	3252	1488	1729	3316	1717	3195	3349	1455
Flt Permitted	0.950			0.950			0.950			0.950		
Satd. Flow (perm)	3286	3283	1626	3318	3252	1464	1727	3316	1690	3184	3349	1432
Right Turn on Red			Yes			Yes			Yes			Yes
Satd. Flow (RTOR)			218			344			218			170
Link Speed (k/h)		80			80			60				60
Link Distance (m)		187.8			279.7			97.7				205.8
Travel Time (s)		8.5			12.6			5.9				12.3
Confl. Peds. (#/hr)	2		2	2		2	2		2	2		2
Peak Hour Factor	1.00	1.00	1.00	1.00	1.00	1.00	1.00	1.00	1.00	1.00	1.00	1.00
Heavy Vehicles (%)	2%	3%	5%	1%	4%	4%	0%	2%	1%	5%	1%	4%
Adj. Flow (vph)	103	1082	59	637	1242	344	70	484	797	451	835	117
Shared Lane Traffic (%)												
Lane Group Flow (vph)	103	1082	59	637	1242	344	70	484	797	451	835	117
Turn Type	Prot	NA	Perm	Prot	NA	Perm	Prot	NA	Perm	Prot	NA	Perm
Protected Phases	5	2		1	6		7	4		3	8	
Permitted Phases			2			6			4			8
Detector Phase	5	2	2	1	6	6	7	4	4	3	8	8
Switch Phase												
Minimum Initial (s)	5.0	5.0	5.0	5.0	5.0	5.0	5.0	5.0	5.0	5.0	5.0	5.0
Minimum Split (s)	11.6	30.6	30.6	11.6	31.6	31.6	11.6	30.6	30.6	11.6	31.6	31.6
Total Split (s)	15.0	63.0	63.0	28.0	76.0	76.0	13.0	31.0	31.0	28.0	46.0	46.0
Total Split (%)	10.0%	42.0%	42.0%	18.7%	50.7%	50.7%	8.7%	20.7%	20.7%	18.7%	30.7%	30.7%
Maximum Green (s)	8.4	56.4	56.4	21.4	69.4	69.4	6.4	24.4	24.4	21.4	39.4	39.4
Yellow Time (s)	3.7	3.7	3.7	3.7	3.7	3.7	3.7	3.7	3.7	3.7	3.7	3.7
All-Red Time (s)	2.9	2.9	2.9	2.9	2.9	2.9	2.9	2.9	2.9	2.9	2.9	2.9
Lost Time Adjust (s)	0.0	0.0	0.0	0.0	0.0	0.0	0.0	0.0	0.0	0.0	0.0	0.0
Total Lost Time (s)	6.6	6.6	6.6	6.6	6.6	6.6	6.6	6.6	6.6	6.6	6.6	6.6
Lead/Lag	Lead	Lag	Lag	Lead	Lag	Lag	Lead	Lag	Lag	Lead	Lag	Lag
Lead-Lag Optimize?	Yes	Yes	Yes	Yes	Yes	Yes	Yes	Yes	Yes	Yes	Yes	Yes
Vehicle Extension (s)	3.0	3.0	3.0	3.0	3.0	3.0	3.0	3.0	3.0	3.0	3.0	3.0
Recall Mode	None	C-Max	C-Max	None	C-Max	C-Max	None	Max	Max	None	Max	Max
Walk Time (s)		7.0	7.0		7.0	7.0		7.0	7.0		7.0	7.0
Flash Dont Walk (s)		17.0	17.0		18.0	18.0		17.0	17.0		18.0	18.0
Pedestrian Calls (#/hr)		2	2		2	2		2	2		2	2
Act Effct Green (s)	8.2	56.4	56.4	21.4	69.6	69.6	6.4	24.4	24.4	21.4	39.4	39.4
Actuated g/C Ratio	0.05	0.38	0.38	0.14	0.46	0.46	0.04	0.16	0.16	0.14	0.26	0.26

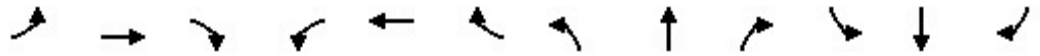

Lane Group	EBL	EBT	EBR	WBL	WBT	WBR	NBL	NBT	NBR	SBL	SBT	SBR
v/c Ratio	0.58	0.88	0.08	1.35	0.82	0.40	0.96	0.90	1.74	0.99	0.95	0.23
Control Delay	82.3	52.9	0.2	216.5	40.6	3.6	163.5	81.8	369.3	103.3	74.5	2.1
Queue Delay	0.0	0.0	0.0	0.0	0.0	0.0	0.0	0.0	0.0	0.0	0.0	0.0
Total Delay	82.3	52.9	0.2	216.5	40.6	3.6	163.5	81.8	369.3	103.3	74.5	2.1
LOS	F	D	A	F	D	A	F	F	F	F	E	A
Approach Delay		52.8			85.3			255.6			77.7	
Approach LOS		D			F			F			E	
Queue Length 50th (m)	14.4	144.7	0.0	~117.1	153.4	0.0	19.5	69.3	~272.1	64.5	119.1	0.0
Queue Length 95th (m)	23.9	172.2	0.0	#151.9	181.3	15.6	#48.9	#97.2	#344.7	#97.2	#155.7	2.9
Internal Link Dist (m)		163.8			255.7			73.7			181.8	
Turn Bay Length (m)	125.0		150.0	150.0		100.0	50.0		125.0			200.0
Base Capacity (vph)	184	1234	747	473	1509	864	73	539	457	455	879	501
Starvation Cap Reductn	0	0	0	0	0	0	0	0	0	0	0	0
Spillback Cap Reductn	0	0	0	0	0	0	0	0	0	0	0	0
Storage Cap Reductn	0	0	0	0	0	0	0	0	0	0	0	0
Reduced v/c Ratio	0.56	0.88	0.08	1.35	0.82	0.40	0.96	0.90	1.74	0.99	0.95	0.23

Intersection Summary

Area Type: Other
 Cycle Length: 150
 Actuated Cycle Length: 150
 Offset: 31 (21%), Referenced to phase 2:EBT and 6:WBT, Start of Green
 Natural Cycle: 150
 Control Type: Actuated-Coordinated
 Maximum v/c Ratio: 1.74
 Intersection Signal Delay: 114.1 Intersection LOS: F
 Intersection Capacity Utilization 114.0% ICU Level of Service H
 Analysis Period (min) 15
 ~ Volume exceeds capacity, queue is theoretically infinite.
 Queue shown is maximum after two cycles.
 # 95th percentile volume exceeds capacity, queue may be longer.
 Queue shown is maximum after two cycles.

Splits and Phases: 3: Prince of Wales Drive & West Hunt Club Road/Hunt Club Road

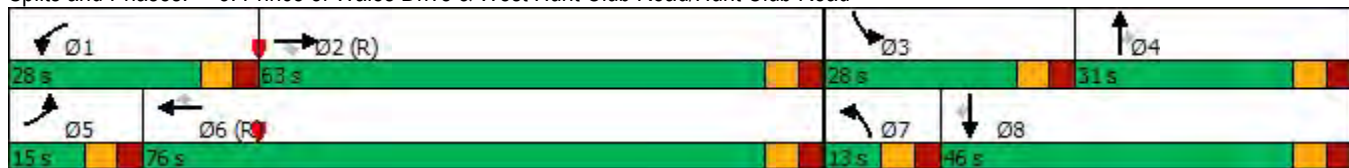



Lane Group	EBL	EBR	NBL	NBT	SBT	SBR
Lane Configurations						
Traffic Volume (vph)	475	187	34	791	1345	177
Future Volume (vph)	475	187	34	791	1345	177
Ideal Flow (vphpl)	1800	1800	1800	1800	1800	1800
Storage Length (m)	70.0	0.0	100.0			0.0
Storage Lanes	1	0	1			0
Taper Length (m)	7.6		7.6			
Lane Util. Factor	0.97	0.95	1.00	0.95	0.95	0.95
Ped Bike Factor	0.95				0.99	
Fr _t	0.958				0.983	
Fl _t Protected	0.965		0.950			
Satd. Flow (prot)	3123	0	1729	3390	3317	0
Fl _t Permitted	0.965		0.118			
Satd. Flow (perm)	3033	0	215	3390	3317	0
Right Turn on Red		Yes				Yes
Satd. Flow (RTOR)	47				26	
Link Speed (k/h)	50			60	60	
Link Distance (m)	195.1			117.9	111.9	
Travel Time (s)	14.0			7.1	6.7	
Confl. Peds. (#/hr)	20	20	20			20
Peak Hour Factor	1.00	1.00	1.00	1.00	1.00	1.00
Heavy Vehicles (%)	2%	2%	0%	2%	1%	5%
Adj. Flow (vph)	475	187	34	791	1345	177
Shared Lane Traffic (%)						
Lane Group Flow (vph)	662	0	34	791	1522	0
Turn Type	Prot		Perm	NA	NA	
Protected Phases	4			2	6	
Permitted Phases			2			
Detector Phase	4		2	2	6	
Switch Phase						
Minimum Initial (s)	5.0		5.0	5.0	5.0	
Minimum Split (s)	24.6		24.4	24.4	24.4	
Total Split (s)	33.0		87.0	87.0	87.0	
Total Split (%)	27.5%		72.5%	72.5%	72.5%	
Maximum Green (s)	26.4		80.6	80.6	80.6	
Yellow Time (s)	3.3		3.7	3.7	3.7	
All-Red Time (s)	3.3		2.7	2.7	2.7	
Lost Time Adjust (s)	0.0		0.0	0.0	0.0	
Total Lost Time (s)	6.6		6.4	6.4	6.4	
Lead/Lag						
Lead-Lag Optimize?						
Vehicle Extension (s)	3.0		3.0	3.0	3.0	
Recall Mode	None		C-Max	C-Max	C-Max	
Walk Time (s)	7.0		7.0	7.0	7.0	
Flash Dont Walk (s)	11.0		11.0	11.0	11.0	
Pedestrian Calls (#/hr)	0		0	0	0	
Act Effct Green (s)	25.9		81.1	81.1	81.1	
Actuated g/C Ratio	0.22		0.68	0.68	0.68	
v/c Ratio	0.93		0.23	0.35	0.68	



Lane Group	EBL	EBR	NBL	NBT	SBT	SBR
Control Delay	63.9		12.6	8.8	13.4	
Queue Delay	0.0		0.0	0.0	0.0	
Total Delay	63.9		12.6	8.8	13.4	
LOS	E		B	A	B	
Approach Delay	63.9			8.9	13.4	
Approach LOS	E			A	B	
Queue Length 50th (m)	68.1		2.6	35.2	94.2	
Queue Length 95th (m)	#99.0		8.0	44.4	115.4	
Internal Link Dist (m)	171.1			93.9	87.9	
Turn Bay Length (m)	70.0		100.0			
Base Capacity (vph)	723		145	2291	2250	
Starvation Cap Reductn	0		0	0	0	
Spillback Cap Reductn	0		0	0	0	
Storage Cap Reductn	0		0	0	0	
Reduced v/c Ratio	0.92		0.23	0.35	0.68	

Intersection Summary

Area Type: Other
 Cycle Length: 120
 Actuated Cycle Length: 120
 Offset: 0 (0%), Referenced to phase 2:NBT and 6:SBT, Start of Green
 Natural Cycle: 60
 Control Type: Actuated-Coordinated
 Maximum v/c Ratio: 0.93
 Intersection Signal Delay: 23.3
 Intersection LOS: C
 Intersection Capacity Utilization 77.3%
 ICU Level of Service D
 Analysis Period (min) 15
 # 95th percentile volume exceeds capacity, queue may be longer.
 Queue shown is maximum after two cycles.

Splits and Phases: 7: Prince of Wales Drive & Deakin Street



Intersection

Int Delay, s/veh 0.3

Movement EBL EBR NBL NBT SBT SBR

Lane Configurations		↗	↘	↑↑↑	↑↑↑	
Traffic Vol, veh/h	0	36	6	1351	1537	32
Future Vol, veh/h	0	36	6	1351	1537	32
Conflicting Peds, #/hr	20	20	20	0	0	20
Sign Control	Stop	Stop	Free	Free	Free	Free
RT Channelized	-	None	-	None	-	None
Storage Length	-	0	50	-	-	-
Veh in Median Storage, #	0	-	-	0	0	-
Grade, %	0	-	-	0	0	-
Peak Hour Factor	100	100	100	100	100	100
Heavy Vehicles, %	2	2	2	2	2	2
Mvmt Flow	0	36	6	1351	1537	32

Major/Minor Minor2 Major1 Major2

Conflicting Flow All	-	825	1589	0	-	0
Stage 1	-	-	-	-	-	-
Stage 2	-	-	-	-	-	-
Critical Hdwy	-	7.14	5.34	-	-	-
Critical Hdwy Stg 1	-	-	-	-	-	-
Critical Hdwy Stg 2	-	-	-	-	-	-
Follow-up Hdwy	-	3.92	3.12	-	-	-
Pot Cap-1 Maneuver	0	271	201	-	-	-
Stage 1	0	-	-	-	-	-
Stage 2	0	-	-	-	-	-
Platoon blocked, %				-	-	-
Mov Cap-1 Maneuver	-	259	196	-	-	-
Mov Cap-2 Maneuver	-	-	-	-	-	-
Stage 1	-	-	-	-	-	-
Stage 2	-	-	-	-	-	-

Approach EB NB SB

HCM Control Delay, s 21.1 0.1 0
 HCM LOS C

Minor Lane/Major Mvmt NBL NBT EBLn1 SBT SBR

Capacity (veh/h)	196	-	259	-	-
HCM Lane V/C Ratio	0.031	-	0.139	-	-
HCM Control Delay (s)	23.9	-	21.1	-	-
HCM Lane LOS	C	-	C	-	-
HCM 95th %tile Q(veh)	0.1	-	0.5	-	-

Intersection

Int Delay, s/veh 0.6

Movement	WBL	WBR	NBT	NBR	SBL	SBT
Lane Configurations		↗ ↘ ↘ ↘	↗ ↘ ↘ ↘		↗ ↘	↗ ↘
Traffic Vol, veh/h	0	47	1250	16	52	1522
Future Vol, veh/h	0	47	1250	16	52	1522
Conflicting Peds, #/hr	0	0	0	0	0	0
Sign Control	Stop	Stop	Free	Free	Free	Free
RT Channelized	-	None	-	None	-	None
Storage Length	-	0	-	-	0	-
Veh in Median Storage, #	0	-	0	-	-	0
Grade, %	0	-	0	-	-	0
Peak Hour Factor	100	100	100	100	100	100
Heavy Vehicles, %	2	2	2	2	2	2
Mvmt Flow	0	47	1250	16	52	1522

Major/Minor	Minor1	Major1	Major2
Conflicting Flow All	-	633	0 0 1266 0
Stage 1	-	-	- - - -
Stage 2	-	-	- - - -
Critical Hdwy	-	7.14	- - 5.34 -
Critical Hdwy Stg 1	-	-	- - - -
Critical Hdwy Stg 2	-	-	- - - -
Follow-up Hdwy	-	3.92	- - 3.12 -
Pot Cap-1 Maneuver	0	362	- - 291 -
Stage 1	0	-	- - - -
Stage 2	0	-	- - - -
Platoon blocked, %			- - - -
Mov Cap-1 Maneuver	-	362	- - 291 -
Mov Cap-2 Maneuver	-	-	- - - -
Stage 1	-	-	- - - -
Stage 2	-	-	- - - -

Approach	WB	NB	SB
HCM Control Delay, s	16.4	0	0.7
HCM LOS	C		

Minor Lane/Major Mvmt	NBT	NBRWBLn1	SBL	SBT
Capacity (veh/h)	-	-	362	291
HCM Lane V/C Ratio	-	-	0.13	0.179
HCM Control Delay (s)	-	-	16.4	20
HCM Lane LOS	-	-	C	C
HCM 95th %tile Q(veh)	-	-	0.4	0.6

Intersection

Int Delay, s/veh 0.4

Movement	WBL	WBR	NBT	NBR	SBL	SBT
Lane Configurations		↑ ↑ ↑	↑ ↑ ↑			↑ ↑ ↑
Traffic Vol, veh/h	0	70	1287	10	0	1574
Future Vol, veh/h	0	70	1287	10	0	1574
Conflicting Peds, #/hr	0	0	0	0	0	0
Sign Control	Stop	Stop	Free	Free	Free	Free
RT Channelized	-	None	-	None	-	None
Storage Length	-	0	-	-	-	-
Veh in Median Storage, #	0	-	0	-	-	0
Grade, %	0	-	0	-	-	0
Peak Hour Factor	100	100	100	100	100	100
Heavy Vehicles, %	2	2	2	2	2	2
Mvmt Flow	0	70	1287	10	0	1574

Major/Minor	Minor1	Major1	Major2
Conflicting Flow All	-	649	0
Stage 1	-	-	-
Stage 2	-	-	-
Critical Hdwy	-	7.14	-
Critical Hdwy Stg 1	-	-	-
Critical Hdwy Stg 2	-	-	-
Follow-up Hdwy	-	3.92	-
Pot Cap-1 Maneuver	0	354	-
Stage 1	0	-	-
Stage 2	0	-	-
Platoon blocked, %	-	-	-
Mov Cap-1 Maneuver	-	354	-
Mov Cap-2 Maneuver	-	-	-
Stage 1	-	-	-
Stage 2	-	-	-

Approach	WB	NB	SB
HCM Control Delay, s	17.7	0	0
HCM LOS	C		

Minor Lane/Major Mvmt	NBT	NBRWBLn1	SBT
Capacity (veh/h)	-	-	354
HCM Lane V/C Ratio	-	-	0.198
HCM Control Delay (s)	-	-	17.7
HCM Lane LOS	-	-	C
HCM 95th %tile Q(veh)	-	-	0.7

Lanes, Volumes, Timings 2175 Prince of Wales - 2030 AM - auto dealership 80000 sqft new
 3: Prince of Wales Drive & West Hunt Club Road/Hunt Club Road 02/29/2024



Lane Group	EBL	EBT	EBR	WBL	WBT	WBR	NBL	NBT	NBR	SBL	SBT	SBR
Lane Configurations	↗↗	↑↑	↖	↗↗	↑↑	↖	↖	↑↑	↖	↗↗	↑↑	↖
Traffic Volume (vph)	89	863	10	586	1133	462	82	761	969	291	457	215
Future Volume (vph)	89	863	10	586	1133	462	82	761	969	291	457	215
Ideal Flow (vphpl)	1800	1800	1800	1800	1800	1800	1800	1800	1800	1800	1800	1800
Lane Width (m)	3.7	3.5	4.8	3.7	3.5	3.7	3.7	3.5	4.8	3.7	3.5	3.5
Storage Length (m)	125.0		150.0	150.0		100.0	50.0		0.0	125.0		200.0
Storage Lanes	2		1	2		1	1		1	2		1
Taper Length (m)	7.6			7.6			7.6			7.6		
Lane Util. Factor	0.97	0.95	1.00	0.97	0.95	1.00	1.00	0.95	1.00	0.97	0.95	1.00
Ped Bike Factor	1.00		0.98	1.00		0.98	1.00		0.98	1.00		0.98
Fr't			0.850			0.850			0.850			0.850
Flt Protected	0.950			0.950			0.950			0.950		
Satd. Flow (prot)	3022	3161	1535	3225	3252	1488	1662	3349	1683	3195	3221	1427
Flt Permitted	0.950			0.950			0.950			0.950		
Satd. Flow (perm)	3020	3161	1511	3222	3252	1465	1660	3349	1658	3188	3221	1405
Right Turn on Red			Yes			Yes			Yes			Yes
Satd. Flow (RTOR)			182			270			246			200
Link Speed (k/h)		80			80			60				60
Link Distance (m)		187.8			279.7			97.7				205.8
Travel Time (s)		8.5			12.6			5.9				12.3
Confl. Peds. (#/hr)	2		2	2		2	2		2	2		2
Peak Hour Factor	1.00	1.00	1.00	1.00	1.00	1.00	1.00	1.00	1.00	1.00	1.00	1.00
Heavy Vehicles (%)	11%	7%	13%	4%	4%	4%	4%	1%	3%	5%	5%	6%
Adj. Flow (vph)	89	863	10	586	1133	462	82	761	969	291	457	215
Shared Lane Traffic (%)												
Lane Group Flow (vph)	89	863	10	586	1133	462	82	761	969	291	457	215
Turn Type	Prot	NA	Perm	Prot	NA	Perm	Prot	NA	Perm	Prot	NA	Perm
Protected Phases	5	2		1	6		7	4		3	8	
Permitted Phases			2			6			4			8
Detector Phase	5	2	2	1	6	6	7	4	4	3	8	8
Switch Phase												
Minimum Initial (s)	1.0	1.0	1.0	1.0	1.0	1.0	1.0	1.0	1.0	1.0	1.0	1.0
Minimum Split (s)	11.6	31.8	31.8	11.6	34.2	34.2	11.6	31.6	31.6	11.6	31.6	31.6
Total Split (s)	16.0	48.0	48.0	28.0	60.0	60.0	20.0	44.0	44.0	20.0	44.0	44.0
Total Split (%)	11.4%	34.3%	34.3%	20.0%	42.9%	42.9%	14.3%	31.4%	31.4%	14.3%	31.4%	31.4%
Maximum Green (s)	9.4	41.2	41.2	21.4	53.2	53.2	13.4	37.4	37.4	13.4	37.4	37.4
Yellow Time (s)	3.7	4.6	4.6	3.7	4.6	4.6	3.7	3.7	3.7	3.7	3.7	3.7
All-Red Time (s)	2.9	2.2	2.2	2.9	2.2	2.2	2.9	2.9	2.9	2.9	2.9	2.9
Lost Time Adjust (s)	0.0	0.0	0.0	0.0	0.0	0.0	0.0	0.0	0.0	0.0	0.0	0.0
Total Lost Time (s)	6.6	6.8	6.8	6.6	6.8	6.8	6.6	6.6	6.6	6.6	6.6	6.6
Lead/Lag	Lead	Lag	Lag	Lead	Lag	Lag	Lead	Lag	Lag	Lead	Lag	Lag
Lead-Lag Optimize?	Yes	Yes	Yes	Yes	Yes	Yes	Yes	Yes	Yes	Yes	Yes	Yes
Vehicle Extension (s)	3.0	3.0	3.0	3.0	3.0	3.0	3.0	3.0	3.0	3.0	3.0	3.0
Recall Mode	None	C-Max	C-Max	None	C-Max	C-Max	None	Max	Max	None	Max	Max
Walk Time (s)		7.0	7.0		7.0	7.0		7.0	7.0		7.0	7.0
Flash Dont Walk (s)		18.0	18.0		18.0	18.0		17.0	17.0		17.0	17.0
Pedestrian Calls (#/hr)		2	2		2	2		2	2		2	2
Act Effct Green (s)	8.7	41.2	41.2	21.4	53.9	53.9	11.3	37.4	37.4	13.4	39.5	39.5
Actuated g/C Ratio	0.06	0.29	0.29	0.15	0.38	0.38	0.08	0.27	0.27	0.10	0.28	0.28

Lanes, Volumes, Timings 2175 Prince of Wales - 2030 AM - auto dealership 80000 sqft new
 3: Prince of Wales Drive & West Hunt Club Road/Hunt Club Road 02/29/2024



Lane Group	EBL	EBT	EBR	WBL	WBT	WBR	NBL	NBT	NBR	SBL	SBT	SBR
v/c Ratio	0.48	0.93	0.02	1.19	0.90	0.63	0.61	0.85	1.56	0.95	0.50	0.40
Control Delay	72.0	64.6	0.1	154.4	51.9	18.1	81.1	59.0	284.4	103.4	44.8	8.9
Queue Delay	0.0	0.0	0.0	0.0	0.0	0.0	0.0	0.0	0.0	0.0	0.0	0.0
Total Delay	72.0	64.6	0.1	154.4	51.9	18.1	81.1	59.0	284.4	103.4	44.8	8.9
LOS	E	E	A	F	D	B	F	E	F	F	D	A
Approach Delay		64.6			72.3			180.5			54.5	
Approach LOS		E			E			F			D	
Queue Length 50th (m)	11.4	112.8	0.0	~92.5	143.8	39.6	20.4	97.3	~301.4	38.7	52.0	2.8
Queue Length 95th (m)	19.8	#148.1	0.0	#126.1	#182.4	74.4	36.4	120.2	#374.9	#64.6	68.7	21.7
Internal Link Dist (m)		163.8			255.7			73.7			181.8	
Turn Bay Length (m)	125.0		150.0	150.0		100.0	50.0			125.0		200.0
Base Capacity (vph)	202	930	573	492	1252	730	159	894	623	305	908	539
Starvation Cap Reductn	0	0	0	0	0	0	0	0	0	0	0	0
Spillback Cap Reductn	0	0	0	0	0	0	0	0	0	0	0	0
Storage Cap Reductn	0	0	0	0	0	0	0	0	0	0	0	0
Reduced v/c Ratio	0.44	0.93	0.02	1.19	0.90	0.63	0.52	0.85	1.56	0.95	0.50	0.40

Intersection Summary

Area Type: Other
 Cycle Length: 140
 Actuated Cycle Length: 140
 Offset: 68 (49%), Referenced to phase 2:EBT and 6:WBT, Start of Green
 Natural Cycle: 150
 Control Type: Actuated-Coordinated
 Maximum v/c Ratio: 1.56
 Intersection Signal Delay: 101.3 Intersection LOS: F
 Intersection Capacity Utilization 114.2% ICU Level of Service H
 Analysis Period (min) 15
 ~ Volume exceeds capacity, queue is theoretically infinite.
 Queue shown is maximum after two cycles.
 # 95th percentile volume exceeds capacity, queue may be longer.
 Queue shown is maximum after two cycles.

Splits and Phases: 3: Prince of Wales Drive & West Hunt Club Road/Hunt Club Road

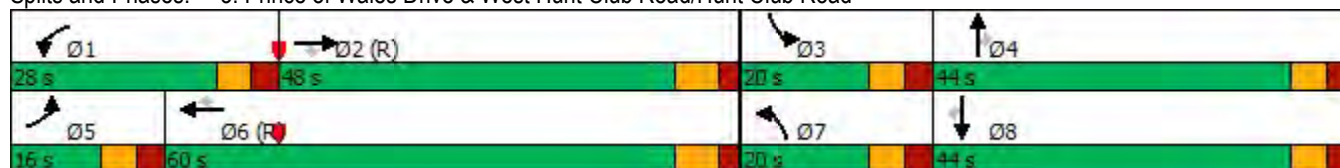

Lanes, Volumes, Timings 2175 Prince of Wales - 2030 AM - auto dealership 80000 sqft new
 7: Prince of Wales Drive & Deakin Street 02/29/2024

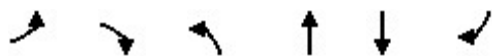

Lane Group	EBL	EBR	NBL	NBT	SBT	SBR
Lane Configurations						
Traffic Volume (vph)	531	23	161	1295	581	417
Future Volume (vph)	531	23	161	1295	581	417
Ideal Flow (vphpl)	1800	1800	1800	1800	1800	1800
Storage Length (m)	70.0	0.0	100.0			0.0
Storage Lanes	1	0	1			0
Taper Length (m)	7.6		7.6			
Lane Util. Factor	0.97	0.95	1.00	0.95	0.95	0.95
Ped Bike Factor	1.00		1.00		0.99	
Frt	0.994				0.937	
Flt Protected	0.954		0.950			
Satd. Flow (prot)	3279	0	1695	3390	3144	0
Flt Permitted	0.954		0.252			
Satd. Flow (perm)	3272	0	449	3390	3144	0
Right Turn on Red		Yes				Yes
Satd. Flow (RTOR)	4				324	
Link Speed (k/h)	50			60	60	
Link Distance (m)	195.1			117.9	111.9	
Travel Time (s)	14.0			7.1	6.7	
Confl. Peds. (#/hr)	2	2	2			2
Peak Hour Factor	1.00	1.00	1.00	1.00	1.00	1.00
Adj. Flow (vph)	531	23	161	1295	581	417
Shared Lane Traffic (%)						
Lane Group Flow (vph)	554	0	161	1295	998	0
Turn Type	Prot		Perm	NA	NA	
Protected Phases	4			2	6	
Permitted Phases			2			
Detector Phase	4		2	2	6	
Switch Phase						
Minimum Initial (s)	1.0		5.0	5.0	5.0	
Minimum Split (s)	33.6		29.4	29.4	29.4	
Total Split (s)	33.6		67.0	67.0	67.0	
Total Split (%)	33.4%		66.6%	66.6%	66.6%	
Maximum Green (s)	27.0		60.6	60.6	60.6	
Yellow Time (s)	3.3		3.7	3.7	3.7	
All-Red Time (s)	3.3		2.7	2.7	2.7	
Lost Time Adjust (s)	0.0		0.0	0.0	0.0	
Total Lost Time (s)	6.6		6.4	6.4	6.4	
Lead/Lag						
Lead-Lag Optimize?						
Vehicle Extension (s)	3.0		3.0	3.0	3.0	
Recall Mode	None		C-Max	C-Max	C-Max	
Walk Time (s)	7.0		7.0	7.0	7.0	
Flash Dont Walk (s)	20.0		16.0	16.0	16.0	
Pedestrian Calls (#/hr)	2		2	2	2	
Act Effct Green (s)	22.0		65.6	65.6	65.6	
Actuated g/C Ratio	0.22		0.65	0.65	0.65	
v/c Ratio	0.77		0.55	0.59	0.46	
Control Delay	44.1		19.8	11.8	6.6	

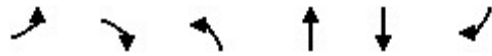

Lane Group	EBL	EBR	NBL	NBT	SBT	SBR
Queue Delay	0.0		0.0	0.0	0.0	
Total Delay	44.1		19.8	11.8	6.6	
LOS	D		B	B	A	
Approach Delay	44.1			12.6	6.6	
Approach LOS	D			B	A	
Queue Length 50th (m)	48.0		14.2	62.4	26.6	
Queue Length 95th (m)	60.7		39.8	91.7	44.3	
Internal Link Dist (m)	171.1			93.9	87.9	
Turn Bay Length (m)	70.0		100.0			
Base Capacity (vph)	882		292	2212	2164	
Starvation Cap Reductn	0		0	0	0	
Spillback Cap Reductn	0		0	0	0	
Storage Cap Reductn	0		0	0	0	
Reduced v/c Ratio	0.63		0.55	0.59	0.46	

Intersection Summary

Area Type:	Other
Cycle Length:	100.6
Actuated Cycle Length:	100.6
Offset:	0 (0%), Referenced to phase 2:NBTL and 6:SBT, Start of Green
Natural Cycle:	80
Control Type:	Actuated-Coordinated
Maximum v/c Ratio:	0.77
Intersection Signal Delay:	16.5
Intersection LOS:	B
Intersection Capacity Utilization	73.9%
ICU Level of Service	D
Analysis Period (min)	15

Splits and Phases: 7: Prince of Wales Drive & Deakin Street

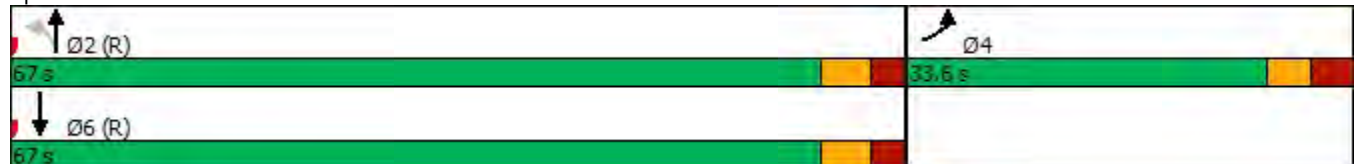

Intersection

Int Delay, s/veh 0.6

Movement EBL EBR NBL NBT SBT SBR

Lane Configurations		↗	↘	↑↑↑	↑↑↑	
Traffic Vol, veh/h	0	90	15	1814	979	84
Future Vol, veh/h	0	90	15	1814	979	84
Conflicting Peds, #/hr	20	20	20	0	0	20
Sign Control	Stop	Stop	Free	Free	Free	Free
RT Channelized	-	None	-	None	-	None
Storage Length	-	0	50	-	-	-
Veh in Median Storage, #	0	-	-	0	0	-
Grade, %	0	-	-	0	0	-
Peak Hour Factor	100	100	100	100	100	100
Heavy Vehicles, %	2	2	2	2	2	2
Mvmt Flow	0	90	15	1814	979	84

Major/Minor Minor2 Major1 Major2

Conflicting Flow All	-	572	1083	0	-	0
Stage 1	-	-	-	-	-	-
Stage 2	-	-	-	-	-	-
Critical Hdwy	-	7.14	5.34	-	-	-
Critical Hdwy Stg 1	-	-	-	-	-	-
Critical Hdwy Stg 2	-	-	-	-	-	-
Follow-up Hdwy	-	3.92	3.12	-	-	-
Pot Cap-1 Maneuver	0	397	357	-	-	-
Stage 1	0	-	-	-	-	-
Stage 2	0	-	-	-	-	-
Platoon blocked, %				-	-	-
Mov Cap-1 Maneuver	-	379	347	-	-	-
Mov Cap-2 Maneuver	-	-	-	-	-	-
Stage 1	-	-	-	-	-	-
Stage 2	-	-	-	-	-	-

Approach EB NB SB

HCM Control Delay, s 17.4 0.1 0
 HCM LOS C

Minor Lane/Major Mvmt NBL NBT EBLn1 SBT SBR

Capacity (veh/h)	347	-	379	-	-
HCM Lane V/C Ratio	0.043	-	0.237	-	-
HCM Control Delay (s)	15.8	-	17.4	-	-
HCM Lane LOS	C	-	C	-	-
HCM 95th %tile Q(veh)	0.1	-	0.9	-	-

Intersection						
Int Delay, s/veh	1.3					
Movement	WBL	WBR	NBT	NBR	SBL	SBT
Lane Configurations		↗ ↘ ↙ ↘	↗ ↘ ↙ ↘		↗ ↘	↗ ↘
Traffic Vol, veh/h	0	16	1805	22	73	985
Future Vol, veh/h	0	16	1805	22	73	985
Conflicting Peds, #/hr	0	0	0	0	0	0
Sign Control	Stop	Stop	Free	Free	Free	Free
RT Channelized	-	None	-	None	-	None
Storage Length	-	0	-	-	0	-
Veh in Median Storage, #	0	-	0	-	-	0
Grade, %	0	-	0	-	-	0
Peak Hour Factor	100	100	100	100	100	100
Heavy Vehicles, %	2	2	2	2	2	2
Mvmt Flow	0	16	1805	22	73	985

Major/Minor	Minor1	Major1	Major2		
Conflicting Flow All	-	914	0	0	1827
Stage 1	-	-	-	-	-
Stage 2	-	-	-	-	-
Critical Hdwy	-	7.14	-	-	5.34
Critical Hdwy Stg 1	-	-	-	-	-
Critical Hdwy Stg 2	-	-	-	-	-
Follow-up Hdwy	-	3.92	-	-	3.12
Pot Cap-1 Maneuver	0	237	-	-	153
Stage 1	0	-	-	-	-
Stage 2	0	-	-	-	-
Platoon blocked, %					
Mov Cap-1 Maneuver	-	237	-	-	153
Mov Cap-2 Maneuver	-	-	-	-	-
Stage 1	-	-	-	-	-
Stage 2	-	-	-	-	-

Approach	WB	NB	SB
HCM Control Delay, s	21.3	0	3.3
HCM LOS	C		

Minor Lane/Major Mvmt	NBT	NBRWBLn1	SBL	SBT
Capacity (veh/h)	-	-	237	153
HCM Lane V/C Ratio	-	-	0.068	0.477
HCM Control Delay (s)	-	-	21.3	48.3
HCM Lane LOS	-	-	C	E
HCM 95th %tile Q(veh)	-	-	0.2	2.2

Intersection						
Int Delay, s/veh	0.2					
Movement	WBL	WBR	NBT	NBR	SBL	SBT
Lane Configurations		↑↑↑	↑↑↑			↑↑↑
Traffic Vol, veh/h	0	24	1806	15	0	1058
Future Vol, veh/h	0	24	1806	15	0	1058
Conflicting Peds, #/hr	0	0	0	0	0	0
Sign Control	Stop	Stop	Free	Free	Free	Free
RT Channelized	-	None	-	None	-	None
Storage Length	-	0	-	-	-	-
Veh in Median Storage, #	0	-	0	-	-	0
Grade, %	0	-	0	-	-	0
Peak Hour Factor	100	100	100	100	100	100
Heavy Vehicles, %	2	2	2	2	2	2
Mvmt Flow	0	24	1806	15	0	1058

Major/Minor	Minor1	Major1	Major2
Conflicting Flow All	-	911	0
Stage 1	-	-	-
Stage 2	-	-	-
Critical Hdwy	-	7.14	-
Critical Hdwy Stg 1	-	-	-
Critical Hdwy Stg 2	-	-	-
Follow-up Hdwy	-	3.92	-
Pot Cap-1 Maneuver	0	238	-
Stage 1	0	-	-
Stage 2	0	-	-
Platoon blocked, %			
Mov Cap-1 Maneuver	-	238	-
Mov Cap-2 Maneuver	-	-	-
Stage 1	-	-	-
Stage 2	-	-	-

Approach	WB	NB	SB
HCM Control Delay, s	21.8	0	0
HCM LOS	C		

Minor Lane/Major Mvmt	NBT	NBRWBLn1	SBT
Capacity (veh/h)	-	-	238
HCM Lane V/C Ratio	-	-	0.101
HCM Control Delay (s)	-	-	21.8
HCM Lane LOS	-	-	C
HCM 95th %tile Q(veh)	-	-	0.3

Lanes, Volumes, Timings

2175 Prince of Wales - 2030 PM - auto dealership 80000 sqft

3: Prince of Wales Drive & West Hunt Club Road/Hunt Club Road

03/01/2024

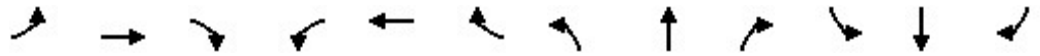

Lane Group	EBL	EBT	EBR	WBL	WBT	WBR	NBL	NBT	NBR	SBL	SBT	SBR
Lane Configurations	↖↖	↗↗	↘	↖↖	↗↗	↘	↖	↗↗	↘	↖↖	↗↗	↘
Traffic Volume (vph)	106	1108	60	652	1273	353	71	495	816	463	855	120
Future Volume (vph)	106	1108	60	652	1273	353	71	495	816	463	855	120
Ideal Flow (vphpl)	1800	1800	1800	1800	1800	1800	1800	1800	1800	1800	1800	1800
Lane Width (m)	3.7	3.5	4.8	3.7	3.5	3.7	3.7	3.5	4.8	3.7	3.5	3.5
Storage Length (m)	125.0		150.0	150.0		100.0	50.0		0.0	125.0		200.0
Storage Lanes	2		1	2		1	1		1	2		1
Taper Length (m)	7.6			7.6			7.6			7.6		
Lane Util. Factor	0.97	0.95	1.00	0.97	0.95	1.00	1.00	0.95	1.00	0.97	0.95	1.00
Ped Bike Factor	1.00		0.98	1.00		0.98	1.00		0.98	1.00		0.98
Fr _t			0.850			0.850			0.850			0.850
Fl _t Protected	0.950			0.950			0.950			0.950		
Satd. Flow (prot)	3288	3283	1651	3321	3252	1488	1729	3316	1717	3195	3349	1455
Fl _t Permitted	0.950			0.950			0.950			0.950		
Satd. Flow (perm)	3286	3283	1626	3318	3252	1464	1727	3316	1690	3184	3349	1432
Right Turn on Red			Yes			Yes			Yes			Yes
Satd. Flow (RTOR)			218			353			218			170
Link Speed (k/h)		80			80			60				60
Link Distance (m)		187.8			279.7			97.7				205.8
Travel Time (s)		8.5			12.6			5.9				12.3
Confl. Peds. (#/hr)	2		2	2		2	2		2	2		2
Peak Hour Factor	1.00	1.00	1.00	1.00	1.00	1.00	1.00	1.00	1.00	1.00	1.00	1.00
Heavy Vehicles (%)	2%	3%	5%	1%	4%	4%	0%	2%	1%	5%	1%	4%
Adj. Flow (vph)	106	1108	60	652	1273	353	71	495	816	463	855	120
Shared Lane Traffic (%)												
Lane Group Flow (vph)	106	1108	60	652	1273	353	71	495	816	463	855	120
Turn Type	Prot	NA	Perm	Prot	NA	Perm	Prot	NA	Perm	Prot	NA	Perm
Protected Phases	5	2		1	6		7	4		3	8	
Permitted Phases			2			6			4			8
Detector Phase	5	2	2	1	6	6	7	4	4	3	8	8
Switch Phase												
Minimum Initial (s)	5.0	5.0	5.0	5.0	5.0	5.0	5.0	5.0	5.0	5.0	5.0	5.0
Minimum Split (s)	11.6	30.6	30.6	11.6	31.6	31.6	11.6	30.6	30.6	11.6	31.6	31.6
Total Split (s)	15.0	63.0	63.0	28.0	76.0	76.0	13.0	31.0	31.0	28.0	46.0	46.0
Total Split (%)	10.0%	42.0%	42.0%	18.7%	50.7%	50.7%	8.7%	20.7%	20.7%	18.7%	30.7%	30.7%
Maximum Green (s)	8.4	56.4	56.4	21.4	69.4	69.4	6.4	24.4	24.4	21.4	39.4	39.4
Yellow Time (s)	3.7	3.7	3.7	3.7	3.7	3.7	3.7	3.7	3.7	3.7	3.7	3.7
All-Red Time (s)	2.9	2.9	2.9	2.9	2.9	2.9	2.9	2.9	2.9	2.9	2.9	2.9
Lost Time Adjust (s)	0.0	0.0	0.0	0.0	0.0	0.0	0.0	0.0	0.0	0.0	0.0	0.0
Total Lost Time (s)	6.6	6.6	6.6	6.6	6.6	6.6	6.6	6.6	6.6	6.6	6.6	6.6
Lead/Lag	Lead	Lag	Lag	Lead	Lag	Lag	Lead	Lag	Lag	Lead	Lag	Lag
Lead-Lag Optimize?	Yes	Yes	Yes	Yes	Yes	Yes	Yes	Yes	Yes	Yes	Yes	Yes
Vehicle Extension (s)	3.0	3.0	3.0	3.0	3.0	3.0	3.0	3.0	3.0	3.0	3.0	3.0
Recall Mode	None	C-Max	C-Max	None	C-Max	C-Max	None	Max	Max	None	Max	Max
Walk Time (s)		7.0	7.0		7.0	7.0		7.0	7.0		7.0	7.0
Flash Dont Walk (s)		17.0	17.0		18.0	18.0		17.0	17.0		18.0	18.0
Pedestrian Calls (#/hr)		2	2		2	2		2	2		2	2
Act Effct Green (s)	8.2	56.4	56.4	21.4	69.6	69.6	6.4	24.4	24.4	21.4	39.4	39.4
Actuated g/C Ratio	0.05	0.38	0.38	0.14	0.46	0.46	0.04	0.16	0.16	0.14	0.26	0.26

Lanes, Volumes, Timings 2175 Prince of Wales - 2030 PM - auto dealership 80000 sqft
 3: Prince of Wales Drive & West Hunt Club Road/Hunt Club Road 03/01/2024

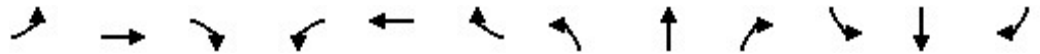

Lane Group	EBL	EBT	EBR	WBL	WBT	WBR	NBL	NBT	NBR	SBL	SBT	SBR
v/c Ratio	0.59	0.90	0.08	1.38	0.84	0.41	0.97	0.92	1.79	1.02	0.97	0.24
Control Delay	83.1	54.8	0.2	229.0	41.9	3.6	167.0	84.6	387.3	108.9	78.8	2.4
Queue Delay	0.0	0.0	0.0	0.0	0.0	0.0	0.0	0.0	0.0	0.0	0.0	0.0
Total Delay	83.1	54.8	0.2	229.0	41.9	3.6	167.0	84.6	387.3	108.9	78.8	2.4
LOS	F	D	A	F	D	A	F	F	F	F	E	A
Approach Delay		54.6			89.5			267.6			82.1	
Approach LOS		D			F			F			F	
Queue Length 50th (m)	14.8	149.9	0.0	~121.5	159.7	0.0	19.8	71.2	~283.1	~68.8	123.0	0.0
Queue Length 95th (m)	24.3	#179.1	0.0	#156.6	188.8	15.8	#50.1	#100.8	#355.0	#100.7	#162.0	3.5
Internal Link Dist (m)		163.8			255.7			73.7			181.8	
Turn Bay Length (m)	125.0		150.0	150.0		100.0	50.0			125.0		200.0
Base Capacity (vph)	184	1234	747	473	1509	869	73	539	457	455	879	501
Starvation Cap Reductn	0	0	0	0	0	0	0	0	0	0	0	0
Spillback Cap Reductn	0	0	0	0	0	0	0	0	0	0	0	0
Storage Cap Reductn	0	0	0	0	0	0	0	0	0	0	0	0
Reduced v/c Ratio	0.58	0.90	0.08	1.38	0.84	0.41	0.97	0.92	1.79	1.02	0.97	0.24

Intersection Summary

Area Type: Other
 Cycle Length: 150
 Actuated Cycle Length: 150
 Offset: 31 (21%), Referenced to phase 2:EBT and 6:WBT, Start of Green
 Natural Cycle: 150
 Control Type: Actuated-Coordinated
 Maximum v/c Ratio: 1.79
 Intersection Signal Delay: 119.5 Intersection LOS: F
 Intersection Capacity Utilization 116.3% ICU Level of Service H
 Analysis Period (min) 15
 ~ Volume exceeds capacity, queue is theoretically infinite.
 Queue shown is maximum after two cycles.
 # 95th percentile volume exceeds capacity, queue may be longer.
 Queue shown is maximum after two cycles.

Splits and Phases: 3: Prince of Wales Drive & West Hunt Club Road/Hunt Club Road

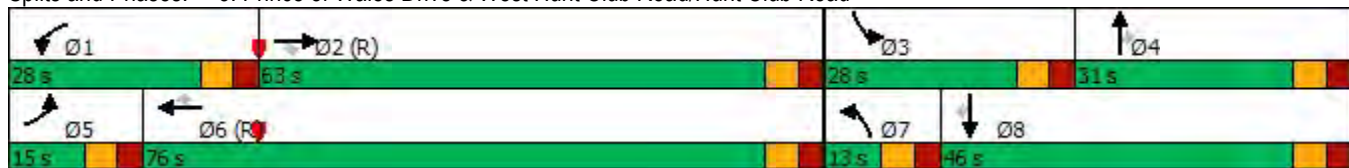



Lane Group	EBL	EBR	NBL	NBT	SBT	SBR
Lane Configurations						
Traffic Volume (vph)	486	191	35	810	1377	181
Future Volume (vph)	486	191	35	810	1377	181
Ideal Flow (vphpl)	1800	1800	1800	1800	1800	1800
Storage Length (m)	70.0	0.0	100.0			0.0
Storage Lanes	1	0	1			0
Taper Length (m)	7.6		7.6			
Lane Util. Factor	0.97	0.95	1.00	0.95	0.95	0.95
Ped Bike Factor	0.95				0.99	
Fr _t	0.958				0.983	
Fl _t Protected	0.965		0.950			
Satd. Flow (prot)	3123	0	1729	3390	3317	0
Fl _t Permitted	0.965		0.110			
Satd. Flow (perm)	3033	0	200	3390	3317	0
Right Turn on Red		Yes				Yes
Satd. Flow (RTOR)	46				26	
Link Speed (k/h)	50			60	60	
Link Distance (m)	195.1			117.9	111.9	
Travel Time (s)	14.0			7.1	6.7	
Confl. Peds. (#/hr)	20	20	20			20
Peak Hour Factor	1.00	1.00	1.00	1.00	1.00	1.00
Heavy Vehicles (%)	2%	2%	0%	2%	1%	5%
Adj. Flow (vph)	486	191	35	810	1377	181
Shared Lane Traffic (%)						
Lane Group Flow (vph)	677	0	35	810	1558	0
Turn Type	Prot		Perm	NA	NA	
Protected Phases	4			2	6	
Permitted Phases			2			
Detector Phase	4		2	2	6	
Switch Phase						
Minimum Initial (s)	5.0		5.0	5.0	5.0	
Minimum Split (s)	24.6		24.4	24.4	24.4	
Total Split (s)	33.0		87.0	87.0	87.0	
Total Split (%)	27.5%		72.5%	72.5%	72.5%	
Maximum Green (s)	26.4		80.6	80.6	80.6	
Yellow Time (s)	3.3		3.7	3.7	3.7	
All-Red Time (s)	3.3		2.7	2.7	2.7	
Lost Time Adjust (s)	0.0		0.0	0.0	0.0	
Total Lost Time (s)	6.6		6.4	6.4	6.4	
Lead/Lag						
Lead-Lag Optimize?						
Vehicle Extension (s)	3.0		3.0	3.0	3.0	
Recall Mode	None		C-Max	C-Max	C-Max	
Walk Time (s)	7.0		7.0	7.0	7.0	
Flash Dont Walk (s)	11.0		11.0	11.0	11.0	
Pedestrian Calls (#/hr)	0		0	0	0	
Act Effct Green (s)	26.1		80.9	80.9	80.9	
Actuated g/C Ratio	0.22		0.67	0.67	0.67	
v/c Ratio	0.95		0.26	0.35	0.69	



Lane Group	EBL	EBR	NBL	NBT	SBT	SBR
Control Delay	66.4		13.8	8.9	13.9	
Queue Delay	0.0		0.0	0.0	0.0	
Total Delay	66.4		13.8	8.9	13.9	
LOS	E		B	A	B	
Approach Delay	66.4			9.1	13.9	
Approach LOS	E			A	B	
Queue Length 50th (m)	70.4		2.8	36.3	98.6	
Queue Length 95th (m)	#102.7		8.5	45.6	120.5	
Internal Link Dist (m)	171.1			93.9	87.9	
Turn Bay Length (m)	70.0		100.0			
Base Capacity (vph)	722		134	2285	2244	
Starvation Cap Reductn	0		0	0	0	
Spillback Cap Reductn	0		0	0	0	
Storage Cap Reductn	0		0	0	0	
Reduced v/c Ratio	0.94		0.26	0.35	0.69	

Intersection Summary

Area Type: Other
 Cycle Length: 120
 Actuated Cycle Length: 120
 Offset: 0 (0%), Referenced to phase 2:NBT and 6:SBT, Start of Green
 Natural Cycle: 65
 Control Type: Actuated-Coordinated
 Maximum v/c Ratio: 0.95
 Intersection Signal Delay: 24.1 Intersection LOS: C
 Intersection Capacity Utilization 78.8% ICU Level of Service D
 Analysis Period (min) 15
 # 95th percentile volume exceeds capacity, queue may be longer.
 Queue shown is maximum after two cycles.

Splits and Phases: 7: Prince of Wales Drive & Deakin Street

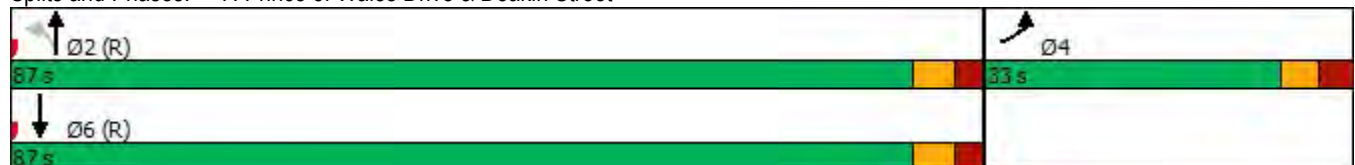

Intersection

Int Delay, s/veh 0.3

Movement EBL EBR NBL NBT SBT SBR

Lane Configurations		↗	↘	↑↑↑	↑↑↑	
Traffic Vol, veh/h	0	36	6	1382	1573	32
Future Vol, veh/h	0	36	6	1382	1573	32
Conflicting Peds, #/hr	20	20	20	0	0	20
Sign Control	Stop	Stop	Free	Free	Free	Free
RT Channelized	-	None	-	None	-	None
Storage Length	-	0	50	-	-	-
Veh in Median Storage, #	0	-	-	0	0	-
Grade, %	0	-	-	0	0	-
Peak Hour Factor	100	100	100	100	100	100
Heavy Vehicles, %	2	2	2	2	2	2
Mvmt Flow	0	36	6	1382	1573	32

Major/Minor Minor2 Major1 Major2

Conflicting Flow All	-	843	1625	0	-	0
Stage 1	-	-	-	-	-	-
Stage 2	-	-	-	-	-	-
Critical Hdwy	-	7.14	5.34	-	-	-
Critical Hdwy Stg 1	-	-	-	-	-	-
Critical Hdwy Stg 2	-	-	-	-	-	-
Follow-up Hdwy	-	3.92	3.12	-	-	-
Pot Cap-1 Maneuver	0	264	193	-	-	-
Stage 1	0	-	-	-	-	-
Stage 2	0	-	-	-	-	-
Platoon blocked, %				-	-	-
Mov Cap-1 Maneuver	-	252	188	-	-	-
Mov Cap-2 Maneuver	-	-	-	-	-	-
Stage 1	-	-	-	-	-	-
Stage 2	-	-	-	-	-	-

Approach EB NB SB

HCM Control Delay, s	21.7	0.1	0
HCM LOS	C		

Minor Lane/Major Mvmt NBL NBT EBLn1 SBT SBR

Capacity (veh/h)	188	-	252	-	-
HCM Lane V/C Ratio	0.032	-	0.143	-	-
HCM Control Delay (s)	24.8	-	21.7	-	-
HCM Lane LOS	C	-	C	-	-
HCM 95th %tile Q(veh)	0.1	-	0.5	-	-

Intersection

Int Delay, s/veh 0.6

Movement	WBL	WBR	NBT	NBR	SBL	SBT
Lane Configurations		↗ ↘ ↘ ↘	↗ ↘ ↘ ↘		↗ ↘	↗ ↘
Traffic Vol, veh/h	0	47	1281	16	52	1558
Future Vol, veh/h	0	47	1281	16	52	1558
Conflicting Peds, #/hr	0	0	0	0	0	0
Sign Control	Stop	Stop	Free	Free	Free	Free
RT Channelized	-	None	-	None	-	None
Storage Length	-	0	-	-	0	-
Veh in Median Storage, #	0	-	0	-	-	0
Grade, %	0	-	0	-	-	0
Peak Hour Factor	100	100	100	100	100	100
Heavy Vehicles, %	2	2	2	2	2	2
Mvmt Flow	0	47	1281	16	52	1558

Major/Minor

	Minor1	Major1	Major2		
Conflicting Flow All	-	649	0	0	1297
Stage 1	-	-	-	-	-
Stage 2	-	-	-	-	-
Critical Hdwy	-	7.14	-	-	5.34
Critical Hdwy Stg 1	-	-	-	-	-
Critical Hdwy Stg 2	-	-	-	-	-
Follow-up Hdwy	-	3.92	-	-	3.12
Pot Cap-1 Maneuver	0	354	-	-	281
Stage 1	0	-	-	-	-
Stage 2	0	-	-	-	-
Platoon blocked, %					
Mov Cap-1 Maneuver	-	354	-	-	281
Mov Cap-2 Maneuver	-	-	-	-	-
Stage 1	-	-	-	-	-
Stage 2	-	-	-	-	-

Approach

	WB	NB	SB
HCM Control Delay, s	16.7	0	0.7
HCM LOS	C		

Minor Lane/Major Mvmt

	NBT	NBRWBLn1	SBL	SBT
Capacity (veh/h)	-	-	354	281
HCM Lane V/C Ratio	-	-	0.133	0.185
HCM Control Delay (s)	-	-	16.7	20.7
HCM Lane LOS	-	-	C	C
HCM 95th %tile Q(veh)	-	-	0.5	0.7

Intersection

Int Delay, s/veh 0.4

Movement	WBL	WBR	NBT	NBR	SBL	SBT
Lane Configurations		↑ ↑ ↑	↑ ↑ ↑			↑ ↑ ↑
Traffic Vol, veh/h	0	70	1318	10	0	1610
Future Vol, veh/h	0	70	1318	10	0	1610
Conflicting Peds, #/hr	0	0	0	0	0	0
Sign Control	Stop	Stop	Free	Free	Free	Free
RT Channelized	-	None	-	None	-	None
Storage Length	-	0	-	-	-	-
Veh in Median Storage, #	0	-	0	-	-	0
Grade, %	0	-	0	-	-	0
Peak Hour Factor	100	100	100	100	100	100
Heavy Vehicles, %	2	2	2	2	2	2
Mvmt Flow	0	70	1318	10	0	1610

Major/Minor	Minor1	Major1	Major2
Conflicting Flow All	-	664	0
Stage 1	-	-	-
Stage 2	-	-	-
Critical Hdwy	-	7.14	-
Critical Hdwy Stg 1	-	-	-
Critical Hdwy Stg 2	-	-	-
Follow-up Hdwy	-	3.92	-
Pot Cap-1 Maneuver	0	346	-
Stage 1	0	-	-
Stage 2	0	-	-
Platoon blocked, %		-	-
Mov Cap-1 Maneuver	-	346	-
Mov Cap-2 Maneuver	-	-	-
Stage 1	-	-	-
Stage 2	-	-	-

Approach	WB	NB	SB
HCM Control Delay, s	18	0	0
HCM LOS	C		

Minor Lane/Major Mvmt	NBT	NBRWBLn1	SBT
Capacity (veh/h)	-	-	346
HCM Lane V/C Ratio	-	-	0.202
HCM Control Delay (s)	-	-	18
HCM Lane LOS	-	-	C
HCM 95th %tile Q(veh)	-	-	0.7

J-2

HOTEL (400 ROOMS)

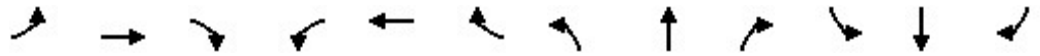

Lane Group	EBL	EBT	EBR	WBL	WBT	WBR	NBL	NBT	NBR	SBL	SBT	SBR
Lane Configurations	↕↕	↕↕	↕	↕↕	↕↕	↕	↕	↕↕	↕	↕↕	↕↕	↕
Traffic Volume (vph)	87	842	10	571	1106	450	96	755	961	284	446	210
Future Volume (vph)	87	842	10	571	1106	450	96	755	961	284	446	210
Ideal Flow (vphpl)	1800	1800	1800	1800	1800	1800	1800	1800	1800	1800	1800	1800
Lane Width (m)	3.7	3.5	4.8	3.7	3.5	3.7	3.7	3.5	4.8	3.7	3.5	3.5
Storage Length (m)	125.0		150.0	150.0		100.0	50.0		0.0	125.0		200.0
Storage Lanes	2		1	2		1	1		1	2		1
Taper Length (m)	7.6			7.6			7.6			7.6		
Lane Util. Factor	0.97	0.95	1.00	0.97	0.95	1.00	1.00	0.95	1.00	0.97	0.95	1.00
Ped Bike Factor	1.00		0.98	1.00		0.98	1.00		0.98	1.00		0.98
Fr _t			0.850			0.850			0.850			0.850
Fl _t Protected	0.950			0.950			0.950			0.950		
Satd. Flow (prot)	3022	3161	1535	3225	3252	1488	1662	3349	1683	3195	3221	1427
Fl _t Permitted	0.950			0.950			0.950			0.950		
Satd. Flow (perm)	3020	3161	1511	3222	3252	1465	1659	3349	1658	3188	3221	1405
Right Turn on Red			Yes			Yes			Yes			Yes
Satd. Flow (RTOR)			182			271			248			194
Link Speed (k/h)		80			80			60				60
Link Distance (m)		187.8			279.7			97.7				205.8
Travel Time (s)		8.5			12.6			5.9				12.3
Confl. Peds. (#/hr)	2		2	2		2	2		2	2		2
Peak Hour Factor	1.00	1.00	1.00	1.00	1.00	1.00	1.00	1.00	1.00	1.00	1.00	1.00
Heavy Vehicles (%)	11%	7%	13%	4%	4%	4%	4%	1%	3%	5%	5%	6%
Adj. Flow (vph)	87	842	10	571	1106	450	96	755	961	284	446	210
Shared Lane Traffic (%)												
Lane Group Flow (vph)	87	842	10	571	1106	450	96	755	961	284	446	210
Turn Type	Prot	NA	Perm	Prot	NA	Perm	Prot	NA	Perm	Prot	NA	Perm
Protected Phases	5	2		1	6		7	4		3	8	
Permitted Phases			2			6			4			8
Detector Phase	5	2	2	1	6	6	7	4	4	3	8	8
Switch Phase												
Minimum Initial (s)	1.0	1.0	1.0	1.0	1.0	1.0	1.0	1.0	1.0	1.0	1.0	1.0
Minimum Split (s)	11.6	31.8	31.8	11.6	34.2	34.2	11.6	31.6	31.6	11.6	31.6	31.6
Total Split (s)	16.0	48.0	48.0	28.0	60.0	60.0	20.0	44.0	44.0	20.0	44.0	44.0
Total Split (%)	11.4%	34.3%	34.3%	20.0%	42.9%	42.9%	14.3%	31.4%	31.4%	14.3%	31.4%	31.4%
Maximum Green (s)	9.4	41.2	41.2	21.4	53.2	53.2	13.4	37.4	37.4	13.4	37.4	37.4
Yellow Time (s)	3.7	4.6	4.6	3.7	4.6	4.6	3.7	3.7	3.7	3.7	3.7	3.7
All-Red Time (s)	2.9	2.2	2.2	2.9	2.2	2.2	2.9	2.9	2.9	2.9	2.9	2.9
Lost Time Adjust (s)	0.0	0.0	0.0	0.0	0.0	0.0	0.0	0.0	0.0	0.0	0.0	0.0
Total Lost Time (s)	6.6	6.8	6.8	6.6	6.8	6.8	6.6	6.6	6.6	6.6	6.6	6.6
Lead/Lag	Lead	Lag	Lag	Lead	Lag	Lag	Lead	Lag	Lag	Lead	Lag	Lag
Lead-Lag Optimize?	Yes	Yes	Yes	Yes	Yes	Yes	Yes	Yes	Yes	Yes	Yes	Yes
Vehicle Extension (s)	3.0	3.0	3.0	3.0	3.0	3.0	3.0	3.0	3.0	3.0	3.0	3.0
Recall Mode	None	C-Max	C-Max	None	C-Max	C-Max	None	Max	Max	None	Max	Max
Walk Time (s)		7.0	7.0		7.0	7.0		7.0	7.0		7.0	7.0
Flash Dont Walk (s)		18.0	18.0		18.0	18.0		17.0	17.0		17.0	17.0
Pedestrian Calls (#/hr)		2	2		2	2		2	2		2	2
Act Effct Green (s)	8.6	41.2	41.2	21.4	54.0	54.0	11.9	37.4	37.4	13.4	38.9	38.9
Actuated g/C Ratio	0.06	0.29	0.29	0.15	0.39	0.39	0.08	0.27	0.27	0.10	0.28	0.28

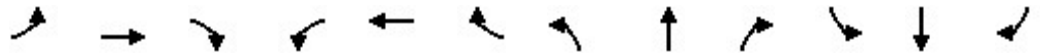

Lane Group	EBL	EBT	EBR	WBL	WBT	WBR	NBL	NBT	NBR	SBL	SBT	SBR
v/c Ratio	0.47	0.91	0.02	1.16	0.88	0.62	0.68	0.84	1.54	0.93	0.50	0.40
Control Delay	71.7	61.7	0.1	143.8	49.8	17.1	85.6	58.5	277.7	98.9	45.1	9.2
Queue Delay	0.0	0.0	0.0	0.0	0.0	0.0	0.0	0.0	0.0	0.0	0.0	0.0
Total Delay	71.7	61.7	0.1	143.8	49.8	17.1	85.6	58.5	277.7	98.9	45.1	9.2
LOS	E	E	A	F	D	B	F	E	F	F	D	A
Approach Delay		62.0			68.1			176.2			53.3	
Approach LOS		E			E			F			D	
Queue Length 50th (m)	11.1	109.0	0.0	~88.5	138.6	36.1	23.9	96.4	~296.3	37.6	51.2	3.0
Queue Length 95th (m)	19.5	#142.2	0.0	#121.8	#169.0	69.8	#41.8	119.2	#369.9	#62.7	66.9	22.0
Internal Link Dist (m)		163.8			255.7			73.7			181.8	
Turn Bay Length (m)	125.0		150.0	150.0		100.0	50.0			125.0		200.0
Base Capacity (vph)	202	930	573	492	1253	731	159	894	624	305	895	530
Starvation Cap Reductn	0	0	0	0	0	0	0	0	0	0	0	0
Spillback Cap Reductn	0	0	0	0	0	0	0	0	0	0	0	0
Storage Cap Reductn	0	0	0	0	0	0	0	0	0	0	0	0
Reduced v/c Ratio	0.43	0.91	0.02	1.16	0.88	0.62	0.60	0.84	1.54	0.93	0.50	0.40

Intersection Summary

Area Type: Other
 Cycle Length: 140
 Actuated Cycle Length: 140
 Offset: 68 (49%), Referenced to phase 2:EBT and 6:WBT, Start of Green
 Natural Cycle: 150
 Control Type: Actuated-Coordinated
 Maximum v/c Ratio: 1.54
 Intersection Signal Delay: 98.4 Intersection LOS: F
 Intersection Capacity Utilization 112.8% ICU Level of Service H
 Analysis Period (min) 15
 ~ Volume exceeds capacity, queue is theoretically infinite.
 Queue shown is maximum after two cycles.
 # 95th percentile volume exceeds capacity, queue may be longer.
 Queue shown is maximum after two cycles.

Splits and Phases: 3: Prince of Wales Drive & West Hunt Club Road/Hunt Club Road



Lanes, Volumes, Timings
7: Prince of Wales Drive & Deakin Street

2175 Prince of Wales - 2025 AM - hotel 400 rooms

02/29/2024



Lane Group	EBL	EBR	NBL	NBT	SBT	SBR
Lane Configurations						
Traffic Volume (vph)	517	22	158	1263	576	412
Future Volume (vph)	517	22	158	1263	576	412
Ideal Flow (vphpl)	1800	1800	1800	1800	1800	1800
Storage Length (m)	70.0	0.0	100.0			0.0
Storage Lanes	1	0	1			0
Taper Length (m)	7.6		7.6			
Lane Util. Factor	0.97	0.95	1.00	0.95	0.95	0.95
Ped Bike Factor	1.00		1.00		0.99	
Frt	0.994				0.937	
Flt Protected	0.954		0.950			
Satd. Flow (prot)	3279	0	1695	3390	3144	0
Flt Permitted	0.954		0.256			
Satd. Flow (perm)	3272	0	456	3390	3144	0
Right Turn on Red		Yes				Yes
Satd. Flow (RTOR)	4				322	
Link Speed (k/h)	50			60	60	
Link Distance (m)	195.1			117.9	111.9	
Travel Time (s)	14.0			7.1	6.7	
Confl. Peds. (#/hr)	2	2	2			2
Peak Hour Factor	1.00	1.00	1.00	1.00	1.00	1.00
Adj. Flow (vph)	517	22	158	1263	576	412
Shared Lane Traffic (%)						
Lane Group Flow (vph)	539	0	158	1263	988	0
Turn Type	Prot		Perm	NA	NA	
Protected Phases	4			2	6	
Permitted Phases			2			
Detector Phase	4		2	2	6	
Switch Phase						
Minimum Initial (s)	1.0		5.0	5.0	5.0	
Minimum Split (s)	33.6		29.4	29.4	29.4	
Total Split (s)	33.6		67.0	67.0	67.0	
Total Split (%)	33.4%		66.6%	66.6%	66.6%	
Maximum Green (s)	27.0		60.6	60.6	60.6	
Yellow Time (s)	3.3		3.7	3.7	3.7	
All-Red Time (s)	3.3		2.7	2.7	2.7	
Lost Time Adjust (s)	0.0		0.0	0.0	0.0	
Total Lost Time (s)	6.6		6.4	6.4	6.4	
Lead/Lag						
Lead-Lag Optimize?						
Vehicle Extension (s)	3.0		3.0	3.0	3.0	
Recall Mode	None		C-Max	C-Max	C-Max	
Walk Time (s)	7.0		7.0	7.0	7.0	
Flash Dont Walk (s)	20.0		16.0	16.0	16.0	
Pedestrian Calls (#/hr)	2		2	2	2	
Act Effct Green (s)	21.6		66.0	66.0	66.0	
Actuated g/C Ratio	0.21		0.66	0.66	0.66	
v/c Ratio	0.76		0.53	0.57	0.45	
Control Delay	44.0		18.5	11.3	6.5	

Lanes, Volumes, Timings
7: Prince of Wales Drive & Deakin Street

2175 Prince of Wales - 2025 AM - hotel 400 rooms

02/29/2024



Lane Group	EBL	EBR	NBL	NBT	SBT	SBR
Queue Delay	0.0		0.0	0.0	0.0	
Total Delay	44.0		18.5	11.3	6.5	
LOS	D		B	B	A	
Approach Delay	44.0			12.1	6.5	
Approach LOS	D			B	A	
Queue Length 50th (m)	46.8		13.5	59.0	25.5	
Queue Length 95th (m)	58.8		37.9	88.4	43.6	
Internal Link Dist (m)	171.1			93.9	87.9	
Turn Bay Length (m)	70.0		100.0			
Base Capacity (vph)	882		299	2223	2172	
Starvation Cap Reductn	0		0	0	0	
Spillback Cap Reductn	0		0	0	0	
Storage Cap Reductn	0		0	0	0	
Reduced v/c Ratio	0.61		0.53	0.57	0.45	

Intersection Summary

Area Type:	Other
Cycle Length:	100.6
Actuated Cycle Length:	100.6
Offset:	0 (0%), Referenced to phase 2:NBTL and 6:SBT, Start of Green
Natural Cycle:	80
Control Type:	Actuated-Coordinated
Maximum v/c Ratio:	0.76
Intersection Signal Delay:	16.1
Intersection LOS:	B
Intersection Capacity Utilization	73.0%
ICU Level of Service	C
Analysis Period (min)	15

Splits and Phases: 7: Prince of Wales Drive & Deakin Street

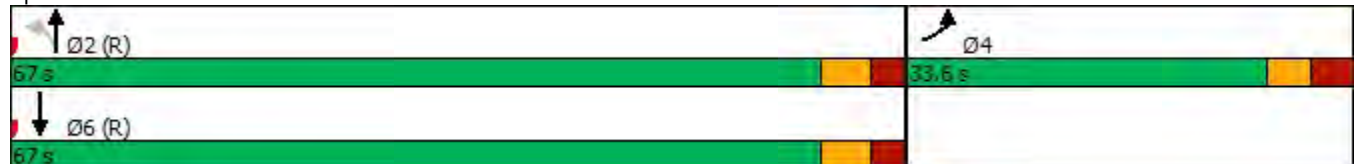

Intersection						
Int Delay, s/veh	0.6					
Movement	EBL	EBR	NBL	NBT	SBT	SBR
Lane Configurations		↗	↘	↑↑↑	↑↑↑	
Traffic Vol, veh/h	0	90	15	1812	967	84
Future Vol, veh/h	0	90	15	1812	967	84
Conflicting Peds, #/hr	20	20	20	0	0	20
Sign Control	Stop	Stop	Free	Free	Free	Free
RT Channelized	-	None	-	None	-	None
Storage Length	-	0	50	-	-	-
Veh in Median Storage, #	0	-	-	0	0	-
Grade, %	0	-	-	0	0	-
Peak Hour Factor	100	100	100	100	100	100
Heavy Vehicles, %	2	2	2	2	2	2
Mvmt Flow	0	90	15	1812	967	84

Major/Minor	Minor2	Major1	Major2		
Conflicting Flow All	-	566	1071	0	-
Stage 1	-	-	-	-	-
Stage 2	-	-	-	-	-
Critical Hdwy	-	7.14	5.34	-	-
Critical Hdwy Stg 1	-	-	-	-	-
Critical Hdwy Stg 2	-	-	-	-	-
Follow-up Hdwy	-	3.92	3.12	-	-
Pot Cap-1 Maneuver	0	400	362	-	-
Stage 1	0	-	-	-	-
Stage 2	0	-	-	-	-
Platoon blocked, %				-	-
Mov Cap-1 Maneuver	-	382	352	-	-
Mov Cap-2 Maneuver	-	-	-	-	-
Stage 1	-	-	-	-	-
Stage 2	-	-	-	-	-

Approach	EB	NB	SB
HCM Control Delay, s	17.3	0.1	0
HCM LOS	C		

Minor Lane/Major Mvmt	NBL	NBT	EBLn1	SBT	SBR
Capacity (veh/h)	352	-	382	-	-
HCM Lane V/C Ratio	0.043	-	0.236	-	-
HCM Control Delay (s)	15.7	-	17.3	-	-
HCM Lane LOS	C	-	C	-	-
HCM 95th %tile Q(veh)	0.1	-	0.9	-	-

Intersection						
Int Delay, s/veh	1.3					
Movement	WBL	WBR	NBT	NBR	SBL	SBT
Lane Configurations		↑↑	↑↑↑		↑	↑↑
Traffic Vol, veh/h	0	32	1760	21	69	989
Future Vol, veh/h	0	32	1760	21	69	989
Conflicting Peds, #/hr	0	0	0	0	0	0
Sign Control	Stop	Stop	Free	Free	Free	Free
RT Channelized	-	None	-	None	-	None
Storage Length	-	0	-	-	0	-
Veh in Median Storage, #	0	-	0	-	-	0
Grade, %	0	-	0	-	-	0
Peak Hour Factor	100	100	100	100	100	100
Heavy Vehicles, %	2	2	2	2	2	2
Mvmt Flow	0	32	1760	21	69	989

Major/Minor	Minor1	Major1	Major2
Conflicting Flow All	-	891	0 0 1781 0
Stage 1	-	-	- - - -
Stage 2	-	-	- - - -
Critical Hdwy	-	7.14	- - 5.34 -
Critical Hdwy Stg 1	-	-	- - - -
Critical Hdwy Stg 2	-	-	- - - -
Follow-up Hdwy	-	3.92	- - 3.12 -
Pot Cap-1 Maneuver	0	245	- - 161 -
Stage 1	0	-	- - - -
Stage 2	0	-	- - - -
Platoon blocked, %			- - - -
Mov Cap-1 Maneuver	-	245	- - 161 -
Mov Cap-2 Maneuver	-	-	- - - -
Stage 1	-	-	- - - -
Stage 2	-	-	- - - -

Approach	WB	NB	SB
HCM Control Delay, s	21.9	0	2.8
HCM LOS	C		

Minor Lane/Major Mvmt	NBT	NBRWBLn1	SBL	SBT
Capacity (veh/h)	-	-	245	161
HCM Lane V/C Ratio	-	-	0.131	0.429
HCM Control Delay (s)	-	-	21.9	43.2
HCM Lane LOS	-	-	C	E
HCM 95th %tile Q(veh)	-	-	0.4	1.9

Intersection						
Int Delay, s/veh	0.4					
Movement	WBL	WBR	NBT	NBR	SBL	SBT
Lane Configurations		↑ ↑ ↑	↑ ↑ ↑			↑ ↑ ↑
Traffic Vol, veh/h	0	49	1778	14	0	1058
Future Vol, veh/h	0	49	1778	14	0	1058
Conflicting Peds, #/hr	0	0	0	0	0	0
Sign Control	Stop	Stop	Free	Free	Free	Free
RT Channelized	-	None	-	None	-	None
Storage Length	-	0	-	-	-	-
Veh in Median Storage, #	0	-	0	-	-	0
Grade, %	0	-	0	-	-	0
Peak Hour Factor	100	100	100	100	100	100
Heavy Vehicles, %	2	2	2	2	2	2
Mvmt Flow	0	49	1778	14	0	1058

Major/Minor	Minor1	Major1	Major2		
Conflicting Flow All	-	896	0	0	-
Stage 1	-	-	-	-	-
Stage 2	-	-	-	-	-
Critical Hdwy	-	7.14	-	-	-
Critical Hdwy Stg 1	-	-	-	-	-
Critical Hdwy Stg 2	-	-	-	-	-
Follow-up Hdwy	-	3.92	-	-	-
Pot Cap-1 Maneuver	0	243	-	-	0
Stage 1	0	-	-	-	0
Stage 2	0	-	-	-	0
Platoon blocked, %			-	-	-
Mov Cap-1 Maneuver	-	243	-	-	-
Mov Cap-2 Maneuver	-	-	-	-	-
Stage 1	-	-	-	-	-
Stage 2	-	-	-	-	-

Approach	WB	NB	SB
HCM Control Delay, s	23.5	0	0
HCM LOS	C		

Minor Lane/Major Mvmt	NBT	NBRWBLn1	SBT
Capacity (veh/h)	-	-	243
HCM Lane V/C Ratio	-	-	0.202
HCM Control Delay (s)	-	-	23.5
HCM Lane LOS	-	-	C
HCM 95th %tile Q(veh)	-	-	0.7

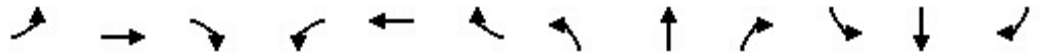

Lane Group	EBL	EBT	EBR	WBL	WBT	WBR	NBL	NBT	NBR	SBL	SBT	SBR
Lane Configurations	↖↗	↑↑	↖	↖↗	↑↑	↖	↖	↑↑	↖	↖↗	↑↑	↖
Traffic Volume (vph)	103	1082	60	648	1242	344	69	483	797	451	851	117
Future Volume (vph)	103	1082	60	648	1242	344	69	483	797	451	851	117
Ideal Flow (vphpl)	1800	1800	1800	1800	1800	1800	1800	1800	1800	1800	1800	1800
Lane Width (m)	3.7	3.5	4.8	3.7	3.5	3.7	3.7	3.5	4.8	3.7	3.5	3.5
Storage Length (m)	125.0		150.0	150.0		100.0	50.0		0.0	125.0		200.0
Storage Lanes	2		1	2		1	1		1	2		1
Taper Length (m)	7.6			7.6			7.6			7.6		
Lane Util. Factor	0.97	0.95	1.00	0.97	0.95	1.00	1.00	0.95	1.00	0.97	0.95	1.00
Ped Bike Factor	1.00		0.98	1.00		0.98	1.00		0.98	1.00		0.98
Fr _t			0.850			0.850			0.850			0.850
Fl _t Protected	0.950			0.950			0.950			0.950		
Satd. Flow (prot)	3288	3283	1651	3321	3252	1488	1729	3316	1717	3195	3349	1455
Fl _t Permitted	0.950			0.950			0.950			0.950		
Satd. Flow (perm)	3286	3283	1626	3318	3252	1464	1727	3316	1690	3184	3349	1432
Right Turn on Red			Yes			Yes			Yes			Yes
Satd. Flow (RTOR)			218			344			218			170
Link Speed (k/h)		80			80			60				60
Link Distance (m)		187.8			279.7			97.7				205.8
Travel Time (s)		8.5			12.6			5.9				12.3
Confl. Peds. (#/hr)	2		2	2		2	2		2	2		2
Peak Hour Factor	1.00	1.00	1.00	1.00	1.00	1.00	1.00	1.00	1.00	1.00	1.00	1.00
Heavy Vehicles (%)	2%	3%	5%	1%	4%	4%	0%	2%	1%	5%	1%	4%
Adj. Flow (vph)	103	1082	60	648	1242	344	69	483	797	451	851	117
Shared Lane Traffic (%)												
Lane Group Flow (vph)	103	1082	60	648	1242	344	69	483	797	451	851	117
Turn Type	Prot	NA	Perm	Prot	NA	Perm	Prot	NA	Perm	Prot	NA	Perm
Protected Phases	5	2		1	6		7	4		3	8	
Permitted Phases			2			6			4			8
Detector Phase	5	2	2	1	6	6	7	4	4	3	8	8
Switch Phase												
Minimum Initial (s)	5.0	5.0	5.0	5.0	5.0	5.0	5.0	5.0	5.0	5.0	5.0	5.0
Minimum Split (s)	11.6	30.6	30.6	11.6	31.6	31.6	11.6	30.6	30.6	11.6	31.6	31.6
Total Split (s)	15.0	63.0	63.0	28.0	76.0	76.0	13.0	31.0	31.0	28.0	46.0	46.0
Total Split (%)	10.0%	42.0%	42.0%	18.7%	50.7%	50.7%	8.7%	20.7%	20.7%	18.7%	30.7%	30.7%
Maximum Green (s)	8.4	56.4	56.4	21.4	69.4	69.4	6.4	24.4	24.4	21.4	39.4	39.4
Yellow Time (s)	3.7	3.7	3.7	3.7	3.7	3.7	3.7	3.7	3.7	3.7	3.7	3.7
All-Red Time (s)	2.9	2.9	2.9	2.9	2.9	2.9	2.9	2.9	2.9	2.9	2.9	2.9
Lost Time Adjust (s)	0.0	0.0	0.0	0.0	0.0	0.0	0.0	0.0	0.0	0.0	0.0	0.0
Total Lost Time (s)	6.6	6.6	6.6	6.6	6.6	6.6	6.6	6.6	6.6	6.6	6.6	6.6
Lead/Lag	Lead	Lag	Lag	Lead	Lag	Lag	Lead	Lag	Lag	Lead	Lag	Lag
Lead-Lag Optimize?	Yes	Yes	Yes	Yes	Yes	Yes	Yes	Yes	Yes	Yes	Yes	Yes
Vehicle Extension (s)	3.0	3.0	3.0	3.0	3.0	3.0	3.0	3.0	3.0	3.0	3.0	3.0
Recall Mode	None	C-Max	C-Max	None	C-Max	C-Max	None	Max	Max	None	Max	Max
Walk Time (s)		7.0	7.0		7.0	7.0		7.0	7.0		7.0	7.0
Flash Dont Walk (s)		17.0	17.0		18.0	18.0		17.0	17.0		18.0	18.0
Pedestrian Calls (#/hr)		2	2		2	2		2	2		2	2
Act Effct Green (s)	8.2	56.4	56.4	21.4	69.6	69.6	6.4	24.4	24.4	21.4	39.4	39.4
Actuated g/C Ratio	0.05	0.38	0.38	0.14	0.46	0.46	0.04	0.16	0.16	0.14	0.26	0.26



Lane Group	EBL	EBT	EBR	WBL	WBT	WBR	NBL	NBT	NBR	SBL	SBT	SBR
v/c Ratio	0.58	0.88	0.08	1.37	0.82	0.40	0.95	0.90	1.74	0.99	0.97	0.23
Control Delay	82.3	52.9	0.2	225.6	40.6	3.6	160.1	81.5	369.3	103.3	77.8	2.1
Queue Delay	0.0	0.0	0.0	0.0	0.0	0.0	0.0	0.0	0.0	0.0	0.0	0.0
Total Delay	82.3	52.9	0.2	225.6	40.6	3.6	160.1	81.5	369.3	103.3	77.8	2.1
LOS	F	D	A	F	D	A	F	F	F	F	E	A
Approach Delay		52.8			88.6			255.5			79.7	
Approach LOS		D			F			F			E	
Queue Length 50th (m)	14.4	144.7	0.0	~120.3	153.4	0.0	19.2	69.2	~272.1	64.5	122.1	0.0
Queue Length 95th (m)	23.9	172.2	0.0	#155.5	181.3	15.6	#48.3	#96.9	#344.7	#97.2	#160.5	2.9
Internal Link Dist (m)		163.8			255.7			73.7			181.8	
Turn Bay Length (m)	125.0		150.0	150.0		100.0	50.0			125.0		200.0
Base Capacity (vph)	184	1234	747	473	1509	864	73	539	457	455	879	501
Starvation Cap Reductn	0	0	0	0	0	0	0	0	0	0	0	0
Spillback Cap Reductn	0	0	0	0	0	0	0	0	0	0	0	0
Storage Cap Reductn	0	0	0	0	0	0	0	0	0	0	0	0
Reduced v/c Ratio	0.56	0.88	0.08	1.37	0.82	0.40	0.95	0.90	1.74	0.99	0.97	0.23

Intersection Summary

Area Type: Other
 Cycle Length: 150
 Actuated Cycle Length: 150
 Offset: 31 (21%), Referenced to phase 2:EBT and 6:WBT, Start of Green
 Natural Cycle: 150
 Control Type: Actuated-Coordinated
 Maximum v/c Ratio: 1.74
 Intersection Signal Delay: 115.5 Intersection LOS: F
 Intersection Capacity Utilization 114.0% ICU Level of Service H
 Analysis Period (min) 15
 ~ Volume exceeds capacity, queue is theoretically infinite.
 Queue shown is maximum after two cycles.
 # 95th percentile volume exceeds capacity, queue may be longer.
 Queue shown is maximum after two cycles.

Splits and Phases: 3: Prince of Wales Drive & West Hunt Club Road/Hunt Club Road

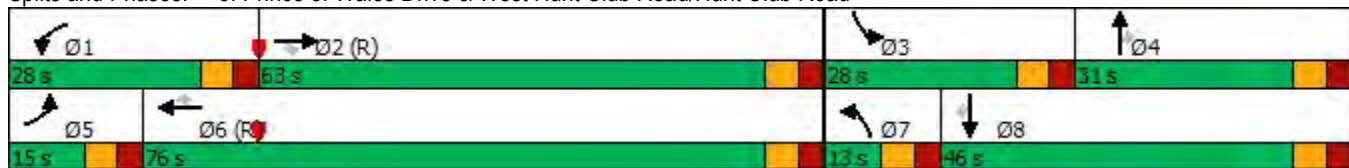

Lanes, Volumes, Timings
7: Prince of Wales Drive & Deakin Street

2175 Prince of Wales - 2025 PM - hotel 400 rooms

03/01/2024



Lane Group	EBL	EBR	NBL	NBT	SBT	SBR
Lane Configurations						
Traffic Volume (vph)	480	187	34	800	1345	176
Future Volume (vph)	480	187	34	800	1345	176
Ideal Flow (vphpl)	1800	1800	1800	1800	1800	1800
Storage Length (m)	70.0	0.0	100.0			0.0
Storage Lanes	1	0	1			0
Taper Length (m)	7.6		7.6			
Lane Util. Factor	0.97	0.95	1.00	0.95	0.95	0.95
Ped Bike Factor	0.95				0.99	
Frt	0.958				0.983	
Flt Protected	0.965		0.950			
Satd. Flow (prot)	3124	0	1729	3390	3317	0
Flt Permitted	0.965		0.118			
Satd. Flow (perm)	3034	0	215	3390	3317	0
Right Turn on Red		Yes				Yes
Satd. Flow (RTOR)	46				26	
Link Speed (k/h)	50			60	60	
Link Distance (m)	195.1			117.9	111.9	
Travel Time (s)	14.0			7.1	6.7	
Confl. Peds. (#/hr)	20	20	20			20
Peak Hour Factor	1.00	1.00	1.00	1.00	1.00	1.00
Heavy Vehicles (%)	2%	2%	0%	2%	1%	5%
Adj. Flow (vph)	480	187	34	800	1345	176
Shared Lane Traffic (%)						
Lane Group Flow (vph)	667	0	34	800	1521	0
Turn Type	Prot		Perm	NA	NA	
Protected Phases	4			2	6	
Permitted Phases			2			
Detector Phase	4		2	2	6	
Switch Phase						
Minimum Initial (s)	5.0		5.0	5.0	5.0	
Minimum Split (s)	24.6		24.4	24.4	24.4	
Total Split (s)	33.0		87.0	87.0	87.0	
Total Split (%)	27.5%		72.5%	72.5%	72.5%	
Maximum Green (s)	26.4		80.6	80.6	80.6	
Yellow Time (s)	3.3		3.7	3.7	3.7	
All-Red Time (s)	3.3		2.7	2.7	2.7	
Lost Time Adjust (s)	0.0		0.0	0.0	0.0	
Total Lost Time (s)	6.6		6.4	6.4	6.4	
Lead/Lag						
Lead-Lag Optimize?						
Vehicle Extension (s)	3.0		3.0	3.0	3.0	
Recall Mode	None		C-Max	C-Max	C-Max	
Walk Time (s)	7.0		7.0	7.0	7.0	
Flash Dont Walk (s)	11.0		11.0	11.0	11.0	
Pedestrian Calls (#/hr)	0		0	0	0	
Act Effct Green (s)	25.9		81.1	81.1	81.1	
Actuated g/C Ratio	0.22		0.68	0.68	0.68	
v/c Ratio	0.94		0.23	0.35	0.68	



Lane Group	EBL	EBR	NBL	NBT	SBT	SBR
Control Delay	64.8		12.6	8.8	13.4	
Queue Delay	0.0		0.0	0.0	0.0	
Total Delay	64.8		12.6	8.8	13.4	
LOS	E		B	A	B	
Approach Delay	64.8			9.0	13.4	
Approach LOS	E			A	B	
Queue Length 50th (m)	68.9		2.6	35.8	94.0	
Queue Length 95th (m)	#100.3		8.0	45.1	115.1	
Internal Link Dist (m)	171.1			93.9	87.9	
Turn Bay Length (m)	70.0		100.0			
Base Capacity (vph)	723		145	2289	2249	
Starvation Cap Reductn	0		0	0	0	
Spillback Cap Reductn	0		0	0	0	
Storage Cap Reductn	0		0	0	0	
Reduced v/c Ratio	0.92		0.23	0.35	0.68	

Intersection Summary

Area Type: Other
 Cycle Length: 120
 Actuated Cycle Length: 120
 Offset: 0 (0%), Referenced to phase 2:NBT and 6:SBT, Start of Green
 Natural Cycle: 60
 Control Type: Actuated-Coordinated
 Maximum v/c Ratio: 0.94
 Intersection Signal Delay: 23.5
 Intersection LOS: C
 Intersection Capacity Utilization 77.4%
 ICU Level of Service D
 Analysis Period (min) 15
 # 95th percentile volume exceeds capacity, queue may be longer.
 Queue shown is maximum after two cycles.

Splits and Phases: 7: Prince of Wales Drive & Deakin Street

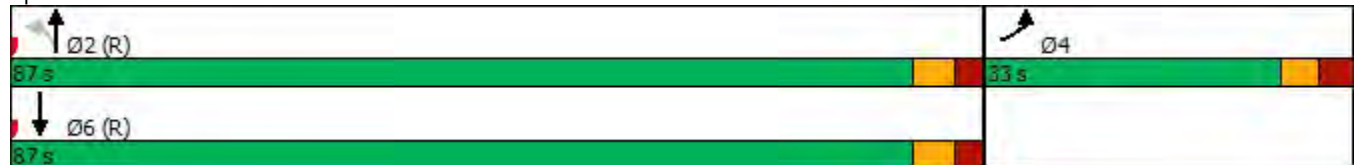

Intersection						
Int Delay, s/veh	0.3					
Movement	EBL	EBR	NBL	NBT	SBT	SBR
Lane Configurations		↗	↘	↑↑↑	↑↑↑	
Traffic Vol, veh/h	0	36	6	1349	1564	32
Future Vol, veh/h	0	36	6	1349	1564	32
Conflicting Peds, #/hr	20	20	20	0	0	20
Sign Control	Stop	Stop	Free	Free	Free	Free
RT Channelized	-	None	-	None	-	None
Storage Length	-	0	50	-	-	-
Veh in Median Storage, #	0	-	-	0	0	-
Grade, %	0	-	-	0	0	-
Peak Hour Factor	100	100	100	100	100	100
Heavy Vehicles, %	2	2	2	2	2	2
Mvmt Flow	0	36	6	1349	1564	32

Major/Minor	Minor2	Major1	Major2		
Conflicting Flow All	-	838	1616	0	-
Stage 1	-	-	-	-	-
Stage 2	-	-	-	-	-
Critical Hdwy	-	7.14	5.34	-	-
Critical Hdwy Stg 1	-	-	-	-	-
Critical Hdwy Stg 2	-	-	-	-	-
Follow-up Hdwy	-	3.92	3.12	-	-
Pot Cap-1 Maneuver	0	266	195	-	-
Stage 1	0	-	-	-	-
Stage 2	0	-	-	-	-
Platoon blocked, %				-	-
Mov Cap-1 Maneuver	-	254	190	-	-
Mov Cap-2 Maneuver	-	-	-	-	-
Stage 1	-	-	-	-	-
Stage 2	-	-	-	-	-

Approach	EB	NB	SB
HCM Control Delay, s	21.5	0.1	0
HCM LOS	C		

Minor Lane/Major Mvmt	NBL	NBT	EBLn1	SBT	SBR
Capacity (veh/h)	190	-	254	-	-
HCM Lane V/C Ratio	0.032	-	0.142	-	-
HCM Control Delay (s)	24.6	-	21.5	-	-
HCM Lane LOS	C	-	C	-	-
HCM 95th %tile Q(veh)	0.1	-	0.5	-	-

Intersection						
Int Delay, s/veh	0.9					
Movement	WBL	WBR	NBT	NBR	SBL	SBT
Lane Configurations		↗ ↘ ↙ ↘	↗ ↘ ↙ ↘		↗ ↘	↗ ↘
Traffic Vol, veh/h	0	46	1256	24	80	1521
Future Vol, veh/h	0	46	1256	24	80	1521
Conflicting Peds, #/hr	0	0	0	0	0	0
Sign Control	Stop	Stop	Free	Free	Free	Free
RT Channelized	-	None	-	None	-	None
Storage Length	-	0	-	-	0	-
Veh in Median Storage, #	0	-	0	-	-	0
Grade, %	0	-	0	-	-	0
Peak Hour Factor	100	100	100	100	100	100
Heavy Vehicles, %	2	2	2	2	2	2
Mvmt Flow	0	46	1256	24	80	1521

Major/Minor	Minor1	Major1	Major2	Major2	Major2
Conflicting Flow All	-	640	0	0	1280
Stage 1	-	-	-	-	-
Stage 2	-	-	-	-	-
Critical Hdwy	-	7.14	-	-	5.34
Critical Hdwy Stg 1	-	-	-	-	-
Critical Hdwy Stg 2	-	-	-	-	-
Follow-up Hdwy	-	3.92	-	-	3.12
Pot Cap-1 Maneuver	0	358	-	-	286
Stage 1	0	-	-	-	-
Stage 2	0	-	-	-	-
Platoon blocked, %			-	-	-
Mov Cap-1 Maneuver	-	358	-	-	286
Mov Cap-2 Maneuver	-	-	-	-	-
Stage 1	-	-	-	-	-
Stage 2	-	-	-	-	-

Approach	WB	NB	SB
HCM Control Delay, s	16.5	0	1.1
HCM LOS	C		

Minor Lane/Major Mvmt	NBT	NBRWBLn1	SBL	SBT
Capacity (veh/h)	-	-	358	286
HCM Lane V/C Ratio	-	-	0.128	0.28
HCM Control Delay (s)	-	-	16.5	22.4
HCM Lane LOS	-	-	C	C
HCM 95th %tile Q(veh)	-	-	0.4	1.1

Intersection						
Int Delay, s/veh	0.4					
Movement	WBL	WBR	NBT	NBR	SBL	SBT
Lane Configurations		↑ ↑ ↑	↑ ↑ ↑			↑ ↑ ↑
Traffic Vol, veh/h	0	69	1286	16	0	1601
Future Vol, veh/h	0	69	1286	16	0	1601
Conflicting Peds, #/hr	0	0	0	0	0	0
Sign Control	Stop	Stop	Free	Free	Free	Free
RT Channelized	-	None	-	None	-	None
Storage Length	-	0	-	-	-	-
Veh in Median Storage, #	0	-	0	-	-	0
Grade, %	0	-	0	-	-	0
Peak Hour Factor	100	100	100	100	100	100
Heavy Vehicles, %	2	2	2	2	2	2
Mvmt Flow	0	69	1286	16	0	1601

Major/Minor	Minor1	Major1	Major2		
Conflicting Flow All	-	651	0	0	-
Stage 1	-	-	-	-	-
Stage 2	-	-	-	-	-
Critical Hdwy	-	7.14	-	-	-
Critical Hdwy Stg 1	-	-	-	-	-
Critical Hdwy Stg 2	-	-	-	-	-
Follow-up Hdwy	-	3.92	-	-	-
Pot Cap-1 Maneuver	0	352	-	-	0
Stage 1	0	-	-	-	0
Stage 2	0	-	-	-	0
Platoon blocked, %			-	-	-
Mov Cap-1 Maneuver	-	352	-	-	-
Mov Cap-2 Maneuver	-	-	-	-	-
Stage 1	-	-	-	-	-
Stage 2	-	-	-	-	-

Approach	WB	NB	SB
HCM Control Delay, s	17.7	0	0
HCM LOS	C		

Minor Lane/Major Mvmt	NBT	NBRWBLn1	SBT
Capacity (veh/h)	-	-	352
HCM Lane V/C Ratio	-	-	0.196
HCM Control Delay (s)	-	-	17.7
HCM Lane LOS	-	-	C
HCM 95th %tile Q(veh)	-	-	0.7

Lanes, Volumes, Timings

2175 Prince of Wales - 2030 AM - hotel 400 rooms

3: Prince of Wales Drive & West Hunt Club Road/Hunt Club Road

02/29/2024

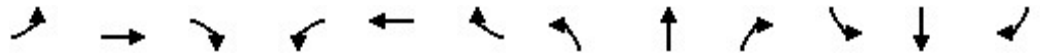

Lane Group	EBL	EBT	EBR	WBL	WBT	WBR	NBL	NBT	NBR	SBL	SBT	SBR
Lane Configurations	↗↗	↑↑	↖	↗↗	↑↑	↖	↖	↑↑	↖	↗↗	↑↑	↖
Traffic Volume (vph)	89	863	10	583	1133	462	97	773	984	291	455	215
Future Volume (vph)	89	863	10	583	1133	462	97	773	984	291	455	215
Ideal Flow (vphpl)	1800	1800	1800	1800	1800	1800	1800	1800	1800	1800	1800	1800
Lane Width (m)	3.7	3.5	4.8	3.7	3.5	3.7	3.7	3.5	4.8	3.7	3.5	3.5
Storage Length (m)	125.0		150.0	150.0		100.0	50.0		0.0	125.0		200.0
Storage Lanes	2		1	2		1	1		1	2		1
Taper Length (m)	7.6			7.6			7.6			7.6		
Lane Util. Factor	0.97	0.95	1.00	0.97	0.95	1.00	1.00	0.95	1.00	0.97	0.95	1.00
Ped Bike Factor	1.00		0.98	1.00		0.98	1.00		0.98	1.00		0.98
Fr _t			0.850			0.850			0.850			0.850
Fl _t Protected	0.950			0.950			0.950			0.950		
Satd. Flow (prot)	3022	3161	1535	3225	3252	1488	1662	3349	1683	3195	3221	1427
Fl _t Permitted	0.950			0.950			0.950			0.950		
Satd. Flow (perm)	3020	3161	1511	3222	3252	1465	1660	3349	1658	3188	3221	1405
Right Turn on Red			Yes			Yes			Yes			Yes
Satd. Flow (RTOR)			182			269			246			192
Link Speed (k/h)		80			80			60				60
Link Distance (m)		187.8			279.7			97.7				205.8
Travel Time (s)		8.5			12.6			5.9				12.3
Confl. Peds. (#/hr)	2		2	2		2	2		2	2		2
Peak Hour Factor	1.00	1.00	1.00	1.00	1.00	1.00	1.00	1.00	1.00	1.00	1.00	1.00
Heavy Vehicles (%)	11%	7%	13%	4%	4%	4%	4%	1%	3%	5%	5%	6%
Adj. Flow (vph)	89	863	10	583	1133	462	97	773	984	291	455	215
Shared Lane Traffic (%)												
Lane Group Flow (vph)	89	863	10	583	1133	462	97	773	984	291	455	215
Turn Type	Prot	NA	Perm	Prot	NA	Perm	Prot	NA	Perm	Prot	NA	Perm
Protected Phases	5	2		1	6		7	4		3	8	
Permitted Phases			2			6			4			8
Detector Phase	5	2	2	1	6	6	7	4	4	3	8	8
Switch Phase												
Minimum Initial (s)	1.0	1.0	1.0	1.0	1.0	1.0	1.0	1.0	1.0	1.0	1.0	1.0
Minimum Split (s)	11.6	31.8	31.8	11.6	34.2	34.2	11.6	31.6	31.6	11.6	31.6	31.6
Total Split (s)	16.0	48.0	48.0	28.0	60.0	60.0	20.0	44.0	44.0	20.0	44.0	44.0
Total Split (%)	11.4%	34.3%	34.3%	20.0%	42.9%	42.9%	14.3%	31.4%	31.4%	14.3%	31.4%	31.4%
Maximum Green (s)	9.4	41.2	41.2	21.4	53.2	53.2	13.4	37.4	37.4	13.4	37.4	37.4
Yellow Time (s)	3.7	4.6	4.6	3.7	4.6	4.6	3.7	3.7	3.7	3.7	3.7	3.7
All-Red Time (s)	2.9	2.2	2.2	2.9	2.2	2.2	2.9	2.9	2.9	2.9	2.9	2.9
Lost Time Adjust (s)	0.0	0.0	0.0	0.0	0.0	0.0	0.0	0.0	0.0	0.0	0.0	0.0
Total Lost Time (s)	6.6	6.8	6.8	6.6	6.8	6.8	6.6	6.6	6.6	6.6	6.6	6.6
Lead/Lag	Lead	Lag	Lag	Lead	Lag	Lag	Lead	Lag	Lag	Lead	Lag	Lag
Lead-Lag Optimize?	Yes	Yes	Yes	Yes	Yes	Yes	Yes	Yes	Yes	Yes	Yes	Yes
Vehicle Extension (s)	3.0	3.0	3.0	3.0	3.0	3.0	3.0	3.0	3.0	3.0	3.0	3.0
Recall Mode	None	C-Max	C-Max	None	C-Max	C-Max	None	Max	Max	None	Max	Max
Walk Time (s)		7.0	7.0		7.0	7.0		7.0	7.0		7.0	7.0
Flash Dont Walk (s)		18.0	18.0		18.0	18.0		17.0	17.0		17.0	17.0
Pedestrian Calls (#/hr)		2	2		2	2		2	2		2	2
Act Effct Green (s)	8.7	41.2	41.2	21.4	53.9	53.9	11.9	37.4	37.4	13.4	38.9	38.9
Actuated g/C Ratio	0.06	0.29	0.29	0.15	0.38	0.38	0.08	0.27	0.27	0.10	0.28	0.28



Lane Group	EBL	EBT	EBR	WBL	WBT	WBR	NBL	NBT	NBR	SBL	SBT	SBR
v/c Ratio	0.48	0.93	0.02	1.18	0.90	0.63	0.68	0.86	1.58	0.95	0.51	0.41
Control Delay	72.0	64.6	0.1	152.2	51.9	18.2	85.8	60.1	294.8	103.4	45.3	10.0
Queue Delay	0.0	0.0	0.0	0.0	0.0	0.0	0.0	0.0	0.0	0.0	0.0	0.0
Total Delay	72.0	64.6	0.1	152.2	51.9	18.2	85.8	60.1	294.8	103.4	45.3	10.0
LOS	E	E	A	F	D	B	F	E	F	F	D	A
Approach Delay		64.6			71.6			186.0			55.0	
Approach LOS		E			E			F			E	
Queue Length 50th (m)	11.4	112.8	0.0	~91.8	143.8	39.8	24.2	99.3	~309.5	38.7	52.3	4.4
Queue Length 95th (m)	19.8	#148.1	0.0	#125.3	#182.4	74.7	#42.4	#124.6	#383.0	#64.6	68.4	23.8
Internal Link Dist (m)		163.8			255.7			73.7			181.8	
Turn Bay Length (m)	125.0		150.0	150.0		100.0	50.0			125.0		200.0
Base Capacity (vph)	202	930	573	492	1252	729	159	894	623	305	894	529
Starvation Cap Reductn	0	0	0	0	0	0	0	0	0	0	0	0
Spillback Cap Reductn	0	0	0	0	0	0	0	0	0	0	0	0
Storage Cap Reductn	0	0	0	0	0	0	0	0	0	0	0	0
Reduced v/c Ratio	0.44	0.93	0.02	1.18	0.90	0.63	0.61	0.86	1.58	0.95	0.51	0.41

Intersection Summary

Area Type: Other
 Cycle Length: 140
 Actuated Cycle Length: 140
 Offset: 68 (49%), Referenced to phase 2:EBT and 6:WBT, Start of Green
 Natural Cycle: 150
 Control Type: Actuated-Coordinated
 Maximum v/c Ratio: 1.58
 Intersection Signal Delay: 103.4 Intersection LOS: F
 Intersection Capacity Utilization 115.1% ICU Level of Service H
 Analysis Period (min) 15
 ~ Volume exceeds capacity, queue is theoretically infinite.
 Queue shown is maximum after two cycles.
 # 95th percentile volume exceeds capacity, queue may be longer.
 Queue shown is maximum after two cycles.

Splits and Phases: 3: Prince of Wales Drive & West Hunt Club Road/Hunt Club Road



Lanes, Volumes, Timings
7: Prince of Wales Drive & Deakin Street

2175 Prince of Wales - 2030 AM - hotel 400 rooms

02/29/2024



Lane Group	EBL	EBR	NBL	NBT	SBT	SBR
Lane Configurations						
Traffic Volume (vph)	530	23	161	1294	589	422
Future Volume (vph)	530	23	161	1294	589	422
Ideal Flow (vphpl)	1800	1800	1800	1800	1800	1800
Storage Length (m)	70.0	0.0	100.0			0.0
Storage Lanes	1	0	1			0
Taper Length (m)	7.6		7.6			
Lane Util. Factor	0.97	0.95	1.00	0.95	0.95	0.95
Ped Bike Factor	1.00		1.00		0.99	
Frt	0.994				0.937	
Flt Protected	0.954		0.950			
Satd. Flow (prot)	3279	0	1695	3390	3144	0
Flt Permitted	0.954		0.248			
Satd. Flow (perm)	3272	0	442	3390	3144	0
Right Turn on Red		Yes				Yes
Satd. Flow (RTOR)	4				325	
Link Speed (k/h)	50			60	60	
Link Distance (m)	195.1			117.9	111.9	
Travel Time (s)	14.0			7.1	6.7	
Confl. Peds. (#/hr)	2	2	2			2
Peak Hour Factor	1.00	1.00	1.00	1.00	1.00	1.00
Adj. Flow (vph)	530	23	161	1294	589	422
Shared Lane Traffic (%)						
Lane Group Flow (vph)	553	0	161	1294	1011	0
Turn Type	Prot		Perm	NA	NA	
Protected Phases	4			2	6	
Permitted Phases			2			
Detector Phase	4		2	2	6	
Switch Phase						
Minimum Initial (s)	1.0		5.0	5.0	5.0	
Minimum Split (s)	33.6		29.4	29.4	29.4	
Total Split (s)	33.6		67.0	67.0	67.0	
Total Split (%)	33.4%		66.6%	66.6%	66.6%	
Maximum Green (s)	27.0		60.6	60.6	60.6	
Yellow Time (s)	3.3		3.7	3.7	3.7	
All-Red Time (s)	3.3		2.7	2.7	2.7	
Lost Time Adjust (s)	0.0		0.0	0.0	0.0	
Total Lost Time (s)	6.6		6.4	6.4	6.4	
Lead/Lag						
Lead-Lag Optimize?						
Vehicle Extension (s)	3.0		3.0	3.0	3.0	
Recall Mode	None		C-Max	C-Max	C-Max	
Walk Time (s)	7.0		7.0	7.0	7.0	
Flash Dont Walk (s)	20.0		16.0	16.0	16.0	
Pedestrian Calls (#/hr)	2		2	2	2	
Act Effct Green (s)	21.9		65.7	65.7	65.7	
Actuated g/C Ratio	0.22		0.65	0.65	0.65	
v/c Ratio	0.77		0.56	0.58	0.47	
Control Delay	44.2		20.3	11.7	6.7	



Lane Group	EBL	EBR	NBL	NBT	SBT	SBR
Queue Delay	0.0		0.0	0.0	0.0	
Total Delay	44.2		20.3	11.7	6.7	
LOS	D		C	B	A	
Approach Delay	44.2			12.7	6.7	
Approach LOS	D			B	A	
Queue Length 50th (m)	48.0		14.3	62.1	27.1	
Queue Length 95th (m)	60.6		40.6	91.8	45.4	
Internal Link Dist (m)	171.1			93.9	87.9	
Turn Bay Length (m)	70.0		100.0			
Base Capacity (vph)	882		288	2213	2165	
Starvation Cap Reductn	0		0	0	0	
Spillback Cap Reductn	0		0	0	0	
Storage Cap Reductn	0		0	0	0	
Reduced v/c Ratio	0.63		0.56	0.58	0.47	

Intersection Summary

Area Type:	Other
Cycle Length:	100.6
Actuated Cycle Length:	100.6
Offset:	0 (0%), Referenced to phase 2:NBT and 6:SBT, Start of Green
Natural Cycle:	80
Control Type:	Actuated-Coordinated
Maximum v/c Ratio:	0.77
Intersection Signal Delay:	16.4
Intersection LOS:	B
Intersection Capacity Utilization:	74.2%
ICU Level of Service:	D
Analysis Period (min):	15

Splits and Phases: 7: Prince of Wales Drive & Deakin Street

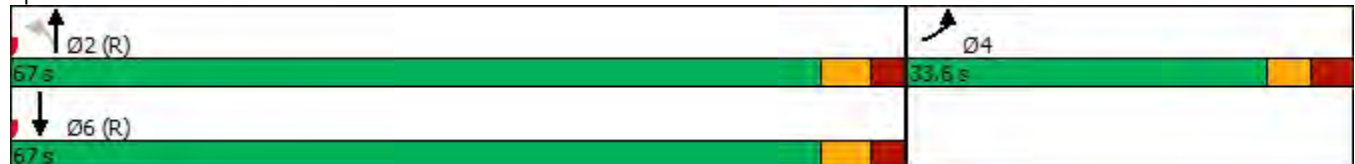

Intersection						
Int Delay, s/veh	0.6					
Movement	EBL	EBR	NBL	NBT	SBT	SBR
Lane Configurations		↗	↘	↑↑↑	↑↑↑	
Traffic Vol, veh/h	0	90	15	1855	988	84
Future Vol, veh/h	0	90	15	1855	988	84
Conflicting Peds, #/hr	20	20	20	0	0	20
Sign Control	Stop	Stop	Free	Free	Free	Free
RT Channelized	-	None	-	None	-	None
Storage Length	-	0	50	-	-	-
Veh in Median Storage, #	0	-	-	0	0	-
Grade, %	0	-	-	0	0	-
Peak Hour Factor	100	100	100	100	100	100
Heavy Vehicles, %	2	2	2	2	2	2
Mvmt Flow	0	90	15	1855	988	84

Major/Minor	Minor2	Major1	Major2		
Conflicting Flow All	-	576	1092	0	-
Stage 1	-	-	-	-	-
Stage 2	-	-	-	-	-
Critical Hdwy	-	7.14	5.34	-	-
Critical Hdwy Stg 1	-	-	-	-	-
Critical Hdwy Stg 2	-	-	-	-	-
Follow-up Hdwy	-	3.92	3.12	-	-
Pot Cap-1 Maneuver	0	394	353	-	-
Stage 1	0	-	-	-	-
Stage 2	0	-	-	-	-
Platoon blocked, %				-	-
Mov Cap-1 Maneuver	-	376	343	-	-
Mov Cap-2 Maneuver	-	-	-	-	-
Stage 1	-	-	-	-	-
Stage 2	-	-	-	-	-

Approach	EB	NB	SB
HCM Control Delay, s	17.6	0.1	0
HCM LOS	C		

Minor Lane/Major Mvmt	NBL	NBT	EBLn1	SBT	SBR
Capacity (veh/h)	343	-	376	-	-
HCM Lane V/C Ratio	0.044	-	0.239	-	-
HCM Control Delay (s)	16	-	17.6	-	-
HCM Lane LOS	C	-	C	-	-
HCM 95th %tile Q(veh)	0.1	-	0.9	-	-

Intersection						
Int Delay, s/veh	1.3					
Movement	WBL	WBR	NBT	NBR	SBL	SBT
Lane Configurations		↑↑↑	↑↑↑		↑	↑↑
Traffic Vol, veh/h	0	32	1804	21	69	985
Future Vol, veh/h	0	32	1804	21	69	985
Conflicting Peds, #/hr	0	0	0	0	0	0
Sign Control	Stop	Stop	Free	Free	Free	Free
RT Channelized	-	None	-	None	-	None
Storage Length	-	0	-	-	0	-
Veh in Median Storage, #	0	-	0	-	-	0
Grade, %	0	-	0	-	-	0
Peak Hour Factor	100	100	100	100	100	100
Heavy Vehicles, %	2	2	2	2	2	2
Mvmt Flow	0	32	1804	21	69	985

Major/Minor	Minor1	Major1	Major2		
Conflicting Flow All	-	913	0	0	1825
Stage 1	-	-	-	-	-
Stage 2	-	-	-	-	-
Critical Hdwy	-	7.14	-	-	5.34
Critical Hdwy Stg 1	-	-	-	-	-
Critical Hdwy Stg 2	-	-	-	-	-
Follow-up Hdwy	-	3.92	-	-	3.12
Pot Cap-1 Maneuver	0	237	-	-	153
Stage 1	0	-	-	-	-
Stage 2	0	-	-	-	-
Platoon blocked, %					
Mov Cap-1 Maneuver	-	237	-	-	153
Mov Cap-2 Maneuver	-	-	-	-	-
Stage 1	-	-	-	-	-
Stage 2	-	-	-	-	-

Approach	WB	NB	SB
HCM Control Delay, s	22.5	0	3
HCM LOS	C		

Minor Lane/Major Mvmt	NBT	NBRWBLn1	SBL	SBT
Capacity (veh/h)	-	-	237	153
HCM Lane V/C Ratio	-	-	0.135	0.451
HCM Control Delay (s)	-	-	22.5	46.5
HCM Lane LOS	-	-	C	E
HCM 95th %tile Q(veh)	-	-	0.5	2.1

Intersection						
Int Delay, s/veh	0.4					
Movement	WBL	WBR	NBT	NBR	SBL	SBT
Lane Configurations		↑ ↑ ↑	↑ ↑ ↑			↑ ↑ ↑
Traffic Vol, veh/h	0	49	1822	14	0	1054
Future Vol, veh/h	0	49	1822	14	0	1054
Conflicting Peds, #/hr	0	0	0	0	0	0
Sign Control	Stop	Stop	Free	Free	Free	Free
RT Channelized	-	None	-	None	-	None
Storage Length	-	0	-	-	-	-
Veh in Median Storage, #	0	-	0	-	-	0
Grade, %	0	-	0	-	-	0
Peak Hour Factor	100	100	100	100	100	100
Heavy Vehicles, %	2	2	2	2	2	2
Mvmt Flow	0	49	1822	14	0	1054

Major/Minor	Minor1	Major1	Major2		
Conflicting Flow All	-	918	0	0	-
Stage 1	-	-	-	-	-
Stage 2	-	-	-	-	-
Critical Hdwy	-	7.14	-	-	-
Critical Hdwy Stg 1	-	-	-	-	-
Critical Hdwy Stg 2	-	-	-	-	-
Follow-up Hdwy	-	3.92	-	-	-
Pot Cap-1 Maneuver	0	235	-	-	0
Stage 1	0	-	-	-	0
Stage 2	0	-	-	-	0
Platoon blocked, %			-	-	-
Mov Cap-1 Maneuver	-	235	-	-	-
Mov Cap-2 Maneuver	-	-	-	-	-
Stage 1	-	-	-	-	-
Stage 2	-	-	-	-	-

Approach	WB	NB	SB
HCM Control Delay, s	24.3	0	0
HCM LOS	C		

Minor Lane/Major Mvmt	NBT	NBRWBLn1	SBT
Capacity (veh/h)	-	-	235
HCM Lane V/C Ratio	-	-	0.209
HCM Control Delay (s)	-	-	24.3
HCM Lane LOS	-	-	C
HCM 95th %tile Q(veh)	-	-	0.8

Lanes, Volumes, Timings

2175 Prince of Wales - 2030 PM - hotel 400 rooms

3: Prince of Wales Drive & West Hunt Club Road/Hunt Club Road

03/01/2024

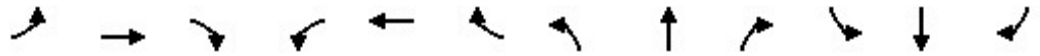

Lane Group	EBL	EBT	EBR	WBL	WBT	WBR	NBL	NBT	NBR	SBL	SBT	SBR
Lane Configurations	↖↖	↗↗	↘	↖↖	↗↗	↘	↖	↗↗	↘	↖↖	↗↗	↘
Traffic Volume (vph)	106	1108	61	663	1273	353	70	494	816	463	871	120
Future Volume (vph)	106	1108	61	663	1273	353	70	494	816	463	871	120
Ideal Flow (vphpl)	1800	1800	1800	1800	1800	1800	1800	1800	1800	1800	1800	1800
Lane Width (m)	3.7	3.5	4.8	3.7	3.5	3.7	3.7	3.5	4.8	3.7	3.5	3.5
Storage Length (m)	125.0		150.0	150.0		100.0	50.0		0.0	125.0		200.0
Storage Lanes	2		1	2		1	1		1	2		1
Taper Length (m)	7.6			7.6			7.6			7.6		
Lane Util. Factor	0.97	0.95	1.00	0.97	0.95	1.00	1.00	0.95	1.00	0.97	0.95	1.00
Ped Bike Factor	1.00		0.98	1.00		0.98	1.00		0.98	1.00		0.98
Fr _t			0.850			0.850			0.850			0.850
Fl _t Protected	0.950			0.950			0.950			0.950		
Satd. Flow (prot)	3288	3283	1651	3321	3252	1488	1729	3316	1717	3195	3349	1455
Fl _t Permitted	0.950			0.950			0.950			0.950		
Satd. Flow (perm)	3286	3283	1626	3318	3252	1464	1727	3316	1690	3184	3349	1432
Right Turn on Red			Yes			Yes			Yes			Yes
Satd. Flow (RTOR)			218			353			218			170
Link Speed (k/h)		80			80			60				60
Link Distance (m)		187.8			279.7			97.7				205.8
Travel Time (s)		8.5			12.6			5.9				12.3
Confl. Peds. (#/hr)	2		2	2		2	2		2	2		2
Peak Hour Factor	1.00	1.00	1.00	1.00	1.00	1.00	1.00	1.00	1.00	1.00	1.00	1.00
Heavy Vehicles (%)	2%	3%	5%	1%	4%	4%	0%	2%	1%	5%	1%	4%
Adj. Flow (vph)	106	1108	61	663	1273	353	70	494	816	463	871	120
Shared Lane Traffic (%)												
Lane Group Flow (vph)	106	1108	61	663	1273	353	70	494	816	463	871	120
Turn Type	Prot	NA	Perm	Prot	NA	Perm	Prot	NA	Perm	Prot	NA	Perm
Protected Phases	5	2		1	6		7	4		3	8	
Permitted Phases			2			6			4			8
Detector Phase	5	2	2	1	6	6	7	4	4	3	8	8
Switch Phase												
Minimum Initial (s)	5.0	5.0	5.0	5.0	5.0	5.0	5.0	5.0	5.0	5.0	5.0	5.0
Minimum Split (s)	11.6	30.6	30.6	11.6	31.6	31.6	11.6	30.6	30.6	11.6	31.6	31.6
Total Split (s)	15.0	63.0	63.0	28.0	76.0	76.0	13.0	31.0	31.0	28.0	46.0	46.0
Total Split (%)	10.0%	42.0%	42.0%	18.7%	50.7%	50.7%	8.7%	20.7%	20.7%	18.7%	30.7%	30.7%
Maximum Green (s)	8.4	56.4	56.4	21.4	69.4	69.4	6.4	24.4	24.4	21.4	39.4	39.4
Yellow Time (s)	3.7	3.7	3.7	3.7	3.7	3.7	3.7	3.7	3.7	3.7	3.7	3.7
All-Red Time (s)	2.9	2.9	2.9	2.9	2.9	2.9	2.9	2.9	2.9	2.9	2.9	2.9
Lost Time Adjust (s)	0.0	0.0	0.0	0.0	0.0	0.0	0.0	0.0	0.0	0.0	0.0	0.0
Total Lost Time (s)	6.6	6.6	6.6	6.6	6.6	6.6	6.6	6.6	6.6	6.6	6.6	6.6
Lead/Lag	Lead	Lag	Lag	Lead	Lag	Lag	Lead	Lag	Lag	Lead	Lag	Lag
Lead-Lag Optimize?	Yes	Yes	Yes	Yes	Yes	Yes	Yes	Yes	Yes	Yes	Yes	Yes
Vehicle Extension (s)	3.0	3.0	3.0	3.0	3.0	3.0	3.0	3.0	3.0	3.0	3.0	3.0
Recall Mode	None	C-Max	C-Max	None	C-Max	C-Max	None	Max	Max	None	Max	Max
Walk Time (s)		7.0	7.0		7.0	7.0		7.0	7.0		7.0	7.0
Flash Dont Walk (s)		17.0	17.0		18.0	18.0		17.0	17.0		18.0	18.0
Pedestrian Calls (#/hr)		2	2		2	2		2	2		2	2
Act Effct Green (s)	8.2	56.4	56.4	21.4	69.6	69.6	6.4	24.4	24.4	21.4	39.4	39.4
Actuated g/C Ratio	0.05	0.38	0.38	0.14	0.46	0.46	0.04	0.16	0.16	0.14	0.26	0.26



Lane Group	EBL	EBT	EBR	WBL	WBT	WBR	NBL	NBT	NBR	SBL	SBT	SBR
v/c Ratio	0.59	0.90	0.08	1.40	0.84	0.41	0.96	0.92	1.79	1.02	0.99	0.24
Control Delay	83.1	54.8	0.2	238.2	41.9	3.6	163.5	84.3	387.3	108.9	82.8	2.4
Queue Delay	0.0	0.0	0.0	0.0	0.0	0.0	0.0	0.0	0.0	0.0	0.0	0.0
Total Delay	83.1	54.8	0.2	238.2	41.9	3.6	163.5	84.3	387.3	108.9	82.8	2.4
LOS	F	D	A	F	D	A	F	F	F	F	F	A
Approach Delay		54.5			92.9			267.5			84.5	
Approach LOS		D			F			F			F	
Queue Length 50th (m)	14.8	149.9	0.0	~124.7	159.7	0.0	19.5	71.0	~283.1	~68.8	126.0	0.0
Queue Length 95th (m)	24.3	#179.1	0.0	#160.1	188.8	15.8	#48.9	#100.5	#355.0	#100.7	#166.8	3.5
Internal Link Dist (m)		163.8			255.7			73.7			181.8	
Turn Bay Length (m)	125.0		150.0	150.0		100.0	50.0			125.0		200.0
Base Capacity (vph)	184	1234	747	473	1509	869	73	539	457	455	879	501
Starvation Cap Reductn	0	0	0	0	0	0	0	0	0	0	0	0
Spillback Cap Reductn	0	0	0	0	0	0	0	0	0	0	0	0
Storage Cap Reductn	0	0	0	0	0	0	0	0	0	0	0	0
Reduced v/c Ratio	0.58	0.90	0.08	1.40	0.84	0.41	0.96	0.92	1.79	1.02	0.99	0.24

Intersection Summary

Area Type: Other
 Cycle Length: 150
 Actuated Cycle Length: 150
 Offset: 31 (21%), Referenced to phase 2:EBT and 6:WBT, Start of Green
 Natural Cycle: 150
 Control Type: Actuated-Coordinated
 Maximum v/c Ratio: 1.79
 Intersection Signal Delay: 121.0 Intersection LOS: F
 Intersection Capacity Utilization 116.3% ICU Level of Service H
 Analysis Period (min) 15
 ~ Volume exceeds capacity, queue is theoretically infinite.
 Queue shown is maximum after two cycles.
 # 95th percentile volume exceeds capacity, queue may be longer.
 Queue shown is maximum after two cycles.

Splits and Phases: 3: Prince of Wales Drive & West Hunt Club Road/Hunt Club Road

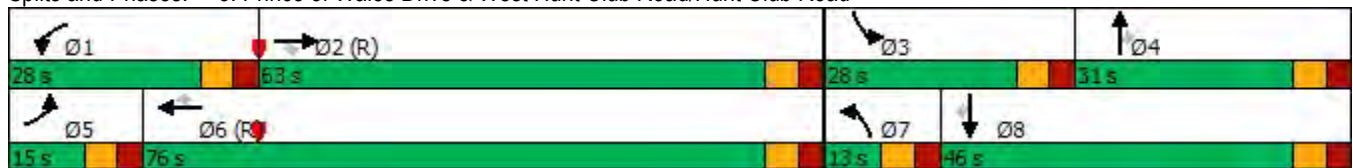

Lanes, Volumes, Timings
7: Prince of Wales Drive & Deakin Street

2175 Prince of Wales - 2030 PM - hotel 400 rooms

03/01/2024



Lane Group	EBL	EBR	NBL	NBT	SBT	SBR
Lane Configurations						
Traffic Volume (vph)	491	191	35	819	1377	180
Future Volume (vph)	491	191	35	819	1377	180
Ideal Flow (vphpl)	1800	1800	1800	1800	1800	1800
Storage Length (m)	70.0	0.0	100.0			0.0
Storage Lanes	1	0	1			0
Taper Length (m)	7.6		7.6			
Lane Util. Factor	0.97	0.95	1.00	0.95	0.95	0.95
Ped Bike Factor	0.95				0.99	
Frt	0.958				0.983	
Flt Protected	0.965		0.950			
Satd. Flow (prot)	3124	0	1729	3390	3317	0
Flt Permitted	0.965		0.110			
Satd. Flow (perm)	3034	0	200	3390	3317	0
Right Turn on Red		Yes				Yes
Satd. Flow (RTOR)	46				26	
Link Speed (k/h)	50			60	60	
Link Distance (m)	195.1			117.9	111.9	
Travel Time (s)	14.0			7.1	6.7	
Confl. Peds. (#/hr)	20	20	20			20
Peak Hour Factor	1.00	1.00	1.00	1.00	1.00	1.00
Heavy Vehicles (%)	2%	2%	0%	2%	1%	5%
Adj. Flow (vph)	491	191	35	819	1377	180
Shared Lane Traffic (%)						
Lane Group Flow (vph)	682	0	35	819	1557	0
Turn Type	Prot		Perm	NA	NA	
Protected Phases	4			2	6	
Permitted Phases			2			
Detector Phase	4		2	2	6	
Switch Phase						
Minimum Initial (s)	5.0		5.0	5.0	5.0	
Minimum Split (s)	24.6		24.4	24.4	24.4	
Total Split (s)	33.0		87.0	87.0	87.0	
Total Split (%)	27.5%		72.5%	72.5%	72.5%	
Maximum Green (s)	26.4		80.6	80.6	80.6	
Yellow Time (s)	3.3		3.7	3.7	3.7	
All-Red Time (s)	3.3		2.7	2.7	2.7	
Lost Time Adjust (s)	0.0		0.0	0.0	0.0	
Total Lost Time (s)	6.6		6.4	6.4	6.4	
Lead/Lag						
Lead-Lag Optimize?						
Vehicle Extension (s)	3.0		3.0	3.0	3.0	
Recall Mode	None		C-Max	C-Max	C-Max	
Walk Time (s)	7.0		7.0	7.0	7.0	
Flash Dont Walk (s)	11.0		11.0	11.0	11.0	
Pedestrian Calls (#/hr)	0		0	0	0	
Act Effct Green (s)	26.2		80.8	80.8	80.8	
Actuated g/C Ratio	0.22		0.67	0.67	0.67	
v/c Ratio	0.95		0.26	0.36	0.69	



Lane Group	EBL	EBR	NBL	NBT	SBT	SBR
Control Delay	66.9		13.8	9.0	13.9	
Queue Delay	0.0		0.0	0.0	0.0	
Total Delay	66.9		13.8	9.0	13.9	
LOS	E		B	A	B	
Approach Delay	66.9			9.2	13.9	
Approach LOS	E			A	B	
Queue Length 50th (m)	71.0		2.8	36.9	98.4	
Queue Length 95th (m)	#103.9		8.5	46.3	120.3	
Internal Link Dist (m)	171.1			93.9	87.9	
Turn Bay Length (m)	70.0		100.0			
Base Capacity (vph)	723		134	2282	2242	
Starvation Cap Reductn	0		0	0	0	
Spillback Cap Reductn	0		0	0	0	
Storage Cap Reductn	0		0	0	0	
Reduced v/c Ratio	0.94		0.26	0.36	0.69	

Intersection Summary

Area Type: Other
 Cycle Length: 120
 Actuated Cycle Length: 120
 Offset: 0 (0%), Referenced to phase 2:NBT and 6:SBT, Start of Green
 Natural Cycle: 65
 Control Type: Actuated-Coordinated
 Maximum v/c Ratio: 0.95
 Intersection Signal Delay: 24.3
 Intersection LOS: C
 Intersection Capacity Utilization 79.0%
 ICU Level of Service D
 Analysis Period (min) 15
 # 95th percentile volume exceeds capacity, queue may be longer.
 Queue shown is maximum after two cycles.

Splits and Phases: 7: Prince of Wales Drive & Deakin Street

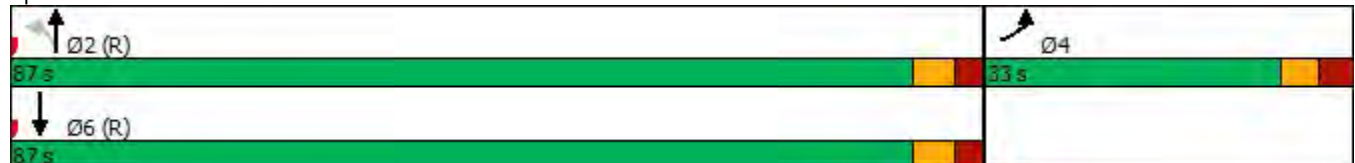

Intersection						
Int Delay, s/veh	0.3					
Movement	EBL	EBR	NBL	NBT	SBT	SBR
Lane Configurations		↗	↘	↑↑↑	↑↑↑	
Traffic Vol, veh/h	0	36	6	1380	1600	32
Future Vol, veh/h	0	36	6	1380	1600	32
Conflicting Peds, #/hr	20	20	20	0	0	20
Sign Control	Stop	Stop	Free	Free	Free	Free
RT Channelized	-	None	-	None	-	None
Storage Length	-	0	50	-	-	-
Veh in Median Storage, #	0	-	-	0	0	-
Grade, %	0	-	-	0	0	-
Peak Hour Factor	100	100	100	100	100	100
Heavy Vehicles, %	2	2	2	2	2	2
Mvmt Flow	0	36	6	1380	1600	32

Major/Minor	Minor2	Major1	Major2		
Conflicting Flow All	-	856	1652	0	-
Stage 1	-	-	-	-	-
Stage 2	-	-	-	-	-
Critical Hdwy	-	7.14	5.34	-	-
Critical Hdwy Stg 1	-	-	-	-	-
Critical Hdwy Stg 2	-	-	-	-	-
Follow-up Hdwy	-	3.92	3.12	-	-
Pot Cap-1 Maneuver	0	259	187	-	-
Stage 1	0	-	-	-	-
Stage 2	0	-	-	-	-
Platoon blocked, %				-	-
Mov Cap-1 Maneuver	-	247	182	-	-
Mov Cap-2 Maneuver	-	-	-	-	-
Stage 1	-	-	-	-	-
Stage 2	-	-	-	-	-

Approach	EB	NB	SB
HCM Control Delay, s	22	0.1	0
HCM LOS	C		

Minor Lane/Major Mvmt	NBL	NBT	EBLn1	SBT	SBR
Capacity (veh/h)	182	-	247	-	-
HCM Lane V/C Ratio	0.033	-	0.146	-	-
HCM Control Delay (s)	25.5	-	22	-	-
HCM Lane LOS	D	-	C	-	-
HCM 95th %tile Q(veh)	0.1	-	0.5	-	-

Intersection						
Int Delay, s/veh	0.9					
Movement	WBL	WBR	NBT	NBR	SBL	SBT
Lane Configurations		↗ ↑↑↑	↗ ↑↑↑		↘ ↑↑	↘ ↑↑
Traffic Vol, veh/h	0	46	1287	24	80	1519
Future Vol, veh/h	0	46	1287	24	80	1519
Conflicting Peds, #/hr	0	0	0	0	0	0
Sign Control	Stop	Stop	Free	Free	Free	Free
RT Channelized	-	None	-	None	-	None
Storage Length	-	0	-	-	0	-
Veh in Median Storage, #	0	-	0	-	-	0
Grade, %	0	-	0	-	-	0
Peak Hour Factor	100	100	100	100	100	100
Heavy Vehicles, %	2	2	2	2	2	2
Mvmt Flow	0	46	1287	24	80	1519

Major/Minor	Minor1	Major1	Major2		
Conflicting Flow All	-	656	0	0	1311
Stage 1	-	-	-	-	-
Stage 2	-	-	-	-	-
Critical Hdwy	-	7.14	-	-	5.34
Critical Hdwy Stg 1	-	-	-	-	-
Critical Hdwy Stg 2	-	-	-	-	-
Follow-up Hdwy	-	3.92	-	-	3.12
Pot Cap-1 Maneuver	0	350	-	-	276
Stage 1	0	-	-	-	-
Stage 2	0	-	-	-	-
Platoon blocked, %					
Mov Cap-1 Maneuver	-	350	-	-	276
Mov Cap-2 Maneuver	-	-	-	-	-
Stage 1	-	-	-	-	-
Stage 2	-	-	-	-	-

Approach	WB	NB	SB
HCM Control Delay, s	16.8	0	1.2
HCM LOS	C		

Minor Lane/Major Mvmt	NBT	NBRWBLn1	SBL	SBT
Capacity (veh/h)	-	-	350	276
HCM Lane V/C Ratio	-	-	0.131	0.29
HCM Control Delay (s)	-	-	16.8	23.3
HCM Lane LOS	-	-	C	C
HCM 95th %tile Q(veh)	-	-	0.4	1.2

Intersection						
Int Delay, s/veh	0.4					
Movement	WBL	WBR	NBT	NBR	SBL	SBT
Lane Configurations		↑ ↑ ↑	↑ ↑ ↑			↑ ↑ ↑
Traffic Vol, veh/h	0	69	1317	16	0	1599
Future Vol, veh/h	0	69	1317	16	0	1599
Conflicting Peds, #/hr	0	0	0	0	0	0
Sign Control	Stop	Stop	Free	Free	Free	Free
RT Channelized	-	None	-	None	-	None
Storage Length	-	0	-	-	-	-
Veh in Median Storage, #	0	-	0	-	-	0
Grade, %	0	-	0	-	-	0
Peak Hour Factor	100	100	100	100	100	100
Heavy Vehicles, %	2	2	2	2	2	2
Mvmt Flow	0	69	1317	16	0	1599

Major/Minor	Minor1	Major1	Major2		
Conflicting Flow All	-	667	0	0	-
Stage 1	-	-	-	-	-
Stage 2	-	-	-	-	-
Critical Hdwy	-	7.14	-	-	-
Critical Hdwy Stg 1	-	-	-	-	-
Critical Hdwy Stg 2	-	-	-	-	-
Follow-up Hdwy	-	3.92	-	-	-
Pot Cap-1 Maneuver	0	344	-	-	0
Stage 1	0	-	-	-	0
Stage 2	0	-	-	-	0
Platoon blocked, %			-	-	-
Mov Cap-1 Maneuver	-	344	-	-	-
Mov Cap-2 Maneuver	-	-	-	-	-
Stage 1	-	-	-	-	-
Stage 2	-	-	-	-	-

Approach	WB	NB	SB
HCM Control Delay, s	18.1	0	0
HCM LOS	C		

Minor Lane/Major Mvmt	NBT	NBRWBLn1	SBT
Capacity (veh/h)	-	-	344
HCM Lane V/C Ratio	-	-	0.201
HCM Control Delay (s)	-	-	18.1
HCM Lane LOS	-	-	C
HCM 95th %tile Q(veh)	-	-	0.7

J-3

OFFICE (80,000 SQFT)

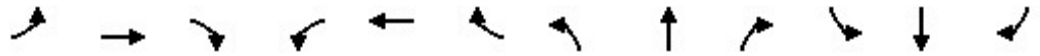

Lane Group	EBL	EBT	EBR	WBL	WBT	WBR	NBL	NBT	NBR	SBL	SBT	SBR
Lane Configurations	↕↕	↕↕	↕	↕↕	↕↕	↕	↕	↕↕	↕	↕↕	↕↕	↕
Traffic Volume (vph)	87	842	10	573	1106	450	72	736	937	284	447	210
Future Volume (vph)	87	842	10	573	1106	450	72	736	937	284	447	210
Ideal Flow (vphpl)	1800	1800	1800	1800	1800	1800	1800	1800	1800	1800	1800	1800
Lane Width (m)	3.7	3.5	4.8	3.7	3.5	3.7	3.7	3.5	4.8	3.7	3.5	3.5
Storage Length (m)	125.0		150.0	150.0		100.0	50.0		0.0	125.0		200.0
Storage Lanes	2		1	2		1	1		1	2		1
Taper Length (m)	7.6			7.6			7.6			7.6		
Lane Util. Factor	0.97	0.95	1.00	0.97	0.95	1.00	1.00	0.95	1.00	0.97	0.95	1.00
Ped Bike Factor	1.00		0.98	1.00		0.98	1.00		0.98	1.00		0.98
Fr _t			0.850			0.850			0.850			0.850
Fl _t Protected	0.950			0.950			0.950			0.950		
Satd. Flow (prot)	3022	3161	1535	3225	3252	1488	1662	3349	1683	3195	3221	1427
Fl _t Permitted	0.950			0.950			0.950			0.950		
Satd. Flow (perm)	3020	3161	1511	3222	3252	1465	1659	3349	1658	3188	3221	1405
Right Turn on Red			Yes			Yes			Yes			Yes
Satd. Flow (RTOR)			182			272			248			207
Link Speed (k/h)		80			80			60				60
Link Distance (m)		187.8			279.7			97.7				205.8
Travel Time (s)		8.5			12.6			5.9				12.3
Confl. Peds. (#/hr)	2		2	2		2	2		2	2		2
Peak Hour Factor	1.00	1.00	1.00	1.00	1.00	1.00	1.00	1.00	1.00	1.00	1.00	1.00
Heavy Vehicles (%)	11%	7%	13%	4%	4%	4%	4%	1%	3%	5%	5%	6%
Adj. Flow (vph)	87	842	10	573	1106	450	72	736	937	284	447	210
Shared Lane Traffic (%)												
Lane Group Flow (vph)	87	842	10	573	1106	450	72	736	937	284	447	210
Turn Type	Prot	NA	Perm	Prot	NA	Perm	Prot	NA	Perm	Prot	NA	Perm
Protected Phases	5	2		1	6		7	4		3	8	
Permitted Phases			2			6			4			8
Detector Phase	5	2	2	1	6	6	7	4	4	3	8	8
Switch Phase												
Minimum Initial (s)	1.0	1.0	1.0	1.0	1.0	1.0	1.0	1.0	1.0	1.0	1.0	1.0
Minimum Split (s)	11.6	31.8	31.8	11.6	34.2	34.2	11.6	31.6	31.6	11.6	31.6	31.6
Total Split (s)	16.0	48.0	48.0	28.0	60.0	60.0	20.0	44.0	44.0	20.0	44.0	44.0
Total Split (%)	11.4%	34.3%	34.3%	20.0%	42.9%	42.9%	14.3%	31.4%	31.4%	14.3%	31.4%	31.4%
Maximum Green (s)	9.4	41.2	41.2	21.4	53.2	53.2	13.4	37.4	37.4	13.4	37.4	37.4
Yellow Time (s)	3.7	4.6	4.6	3.7	4.6	4.6	3.7	3.7	3.7	3.7	3.7	3.7
All-Red Time (s)	2.9	2.2	2.2	2.9	2.2	2.2	2.9	2.9	2.9	2.9	2.9	2.9
Lost Time Adjust (s)	0.0	0.0	0.0	0.0	0.0	0.0	0.0	0.0	0.0	0.0	0.0	0.0
Total Lost Time (s)	6.6	6.8	6.8	6.6	6.8	6.8	6.6	6.6	6.6	6.6	6.6	6.6
Lead/Lag	Lead	Lag	Lag	Lead	Lag	Lag	Lead	Lag	Lag	Lead	Lag	Lag
Lead-Lag Optimize?	Yes	Yes	Yes	Yes	Yes	Yes	Yes	Yes	Yes	Yes	Yes	Yes
Vehicle Extension (s)	3.0	3.0	3.0	3.0	3.0	3.0	3.0	3.0	3.0	3.0	3.0	3.0
Recall Mode	None	C-Max	C-Max	None	C-Max	C-Max	None	Max	Max	None	Max	Max
Walk Time (s)		7.0	7.0		7.0	7.0		7.0	7.0		7.0	7.0
Flash Dont Walk (s)		18.0	18.0		18.0	18.0		17.0	17.0		17.0	17.0
Pedestrian Calls (#/hr)		2	2		2	2		2	2		2	2
Act Effct Green (s)	8.6	41.2	41.2	21.4	54.0	54.0	10.9	37.4	37.4	13.4	42.6	42.6
Actuated g/C Ratio	0.06	0.29	0.29	0.15	0.39	0.39	0.08	0.27	0.27	0.10	0.30	0.30

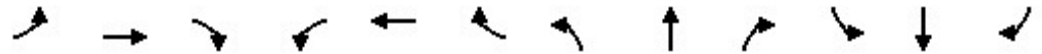

Lane Group	EBL	EBT	EBR	WBL	WBT	WBR	NBL	NBT	NBR	SBL	SBT	SBR
v/c Ratio	0.47	0.91	0.02	1.16	0.88	0.61	0.56	0.82	1.50	0.93	0.46	0.37
Control Delay	71.7	61.7	0.1	145.2	49.8	17.0	78.1	57.1	261.1	98.9	42.6	7.3
Queue Delay	0.0	0.0	0.0	0.0	0.0	0.0	0.0	0.0	0.0	0.0	0.0	0.0
Total Delay	71.7	61.7	0.1	145.2	49.8	17.0	78.1	57.1	261.1	98.9	42.6	7.3
LOS	E	E	A	F	D	B	E	E	F	F	D	A
Approach Delay		62.0			68.5			167.5			51.7	
Approach LOS		E			E			F			D	
Queue Length 50th (m)	11.1	109.0	0.0	~89.0	138.6	35.9	18.0	93.2	~283.4	37.6	50.2	0.6
Queue Length 95th (m)	19.5	#142.2	0.0	#122.5	#169.0	69.5	32.8	115.4	#356.4	#62.7	67.1	18.7
Internal Link Dist (m)		163.8			255.7			73.7			181.8	
Turn Bay Length (m)	125.0		150.0	150.0		100.0	50.0			125.0		200.0
Base Capacity (vph)	202	930	573	492	1253	732	159	894	624	305	980	571
Starvation Cap Reductn	0	0	0	0	0	0	0	0	0	0	0	0
Spillback Cap Reductn	0	0	0	0	0	0	0	0	0	0	0	0
Storage Cap Reductn	0	0	0	0	0	0	0	0	0	0	0	0
Reduced v/c Ratio	0.43	0.91	0.02	1.16	0.88	0.61	0.45	0.82	1.50	0.93	0.46	0.37

Intersection Summary

Area Type: Other
 Cycle Length: 140
 Actuated Cycle Length: 140
 Offset: 68 (49%), Referenced to phase 2:EBT and 6:WBT, Start of Green
 Natural Cycle: 150
 Control Type: Actuated-Coordinated
 Maximum v/c Ratio: 1.50
 Intersection Signal Delay: 94.7
 Intersection Capacity Utilization 111.2%
 Analysis Period (min) 15
 Intersection LOS: F
 ICU Level of Service H

~ Volume exceeds capacity, queue is theoretically infinite.
 Queue shown is maximum after two cycles.

95th percentile volume exceeds capacity, queue may be longer.
 Queue shown is maximum after two cycles.

Splits and Phases: 3: Prince of Wales Drive & West Hunt Club Road/Hunt Club Road



Lanes, Volumes, Timings
7: Prince of Wales Drive & Deakin Street

2175 Prince of Wales - 2025 AM - office 80000 sqft
02/29/2024

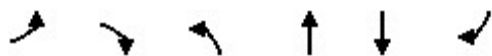

Lane Group	EBL	EBR	NBL	NBT	SBT	SBR
Lane Configurations						
Traffic Volume (vph)	517	22	158	1263	563	403
Future Volume (vph)	517	22	158	1263	563	403
Ideal Flow (vphpl)	1800	1800	1800	1800	1800	1800
Storage Length (m)	70.0	0.0	100.0			0.0
Storage Lanes	1	0	1			0
Taper Length (m)	7.6		7.6			
Lane Util. Factor	0.97	0.95	1.00	0.95	0.95	0.95
Ped Bike Factor	1.00		1.00		0.99	
Frt	0.994				0.937	
Flt Protected	0.954		0.950			
Satd. Flow (prot)	3279	0	1695	3390	3144	0
Flt Permitted	0.954		0.264			
Satd. Flow (perm)	3272	0	471	3390	3144	0
Right Turn on Red		Yes				Yes
Satd. Flow (RTOR)	4				324	
Link Speed (k/h)	50			60	60	
Link Distance (m)	195.1			117.9	111.9	
Travel Time (s)	14.0			7.1	6.7	
Confl. Peds. (#/hr)	2	2	2			2
Peak Hour Factor	1.00	1.00	1.00	1.00	1.00	1.00
Adj. Flow (vph)	517	22	158	1263	563	403
Shared Lane Traffic (%)						
Lane Group Flow (vph)	539	0	158	1263	966	0
Turn Type	Prot		Perm	NA	NA	
Protected Phases	4			2	6	
Permitted Phases			2			
Detector Phase	4		2	2	6	
Switch Phase						
Minimum Initial (s)	1.0		5.0	5.0	5.0	
Minimum Split (s)	33.6		29.4	29.4	29.4	
Total Split (s)	33.6		67.0	67.0	67.0	
Total Split (%)	33.4%		66.6%	66.6%	66.6%	
Maximum Green (s)	27.0		60.6	60.6	60.6	
Yellow Time (s)	3.3		3.7	3.7	3.7	
All-Red Time (s)	3.3		2.7	2.7	2.7	
Lost Time Adjust (s)	0.0		0.0	0.0	0.0	
Total Lost Time (s)	6.6		6.4	6.4	6.4	
Lead/Lag						
Lead-Lag Optimize?						
Vehicle Extension (s)	3.0		3.0	3.0	3.0	
Recall Mode	None		C-Max	C-Max	C-Max	
Walk Time (s)	7.0		7.0	7.0	7.0	
Flash Dont Walk (s)	20.0		16.0	16.0	16.0	
Pedestrian Calls (#/hr)	2		2	2	2	
Act Effct Green (s)	21.6		66.0	66.0	66.0	
Actuated g/C Ratio	0.21		0.66	0.66	0.66	
v/c Ratio	0.76		0.51	0.57	0.44	
Control Delay	44.0		17.6	11.3	6.3	



Lane Group	EBL	EBR	NBL	NBT	SBT	SBR
Queue Delay	0.0		0.0	0.0	0.0	
Total Delay	44.0		17.6	11.3	6.3	
LOS	D		B	B	A	
Approach Delay	44.0			12.0	6.3	
Approach LOS	D			B	A	
Queue Length 50th (m)	46.8		13.2	59.0	24.2	
Queue Length 95th (m)	58.8		36.5	88.4	41.8	
Internal Link Dist (m)	171.1			93.9	87.9	
Turn Bay Length (m)	70.0		100.0			
Base Capacity (vph)	882		308	2223	2173	
Starvation Cap Reductn	0		0	0	0	
Spillback Cap Reductn	0		0	0	0	
Storage Cap Reductn	0		0	0	0	
Reduced v/c Ratio	0.61		0.51	0.57	0.44	

Intersection Summary

Area Type:	Other
Cycle Length:	100.6
Actuated Cycle Length:	100.6
Offset:	0 (0%), Referenced to phase 2:NBTL and 6:SBT, Start of Green
Natural Cycle:	80
Control Type:	Actuated-Coordinated
Maximum v/c Ratio:	0.76
Intersection Signal Delay:	16.0
Intersection LOS:	B
Intersection Capacity Utilization	72.3%
ICU Level of Service	C
Analysis Period (min)	15

Splits and Phases: 7: Prince of Wales Drive & Deakin Street

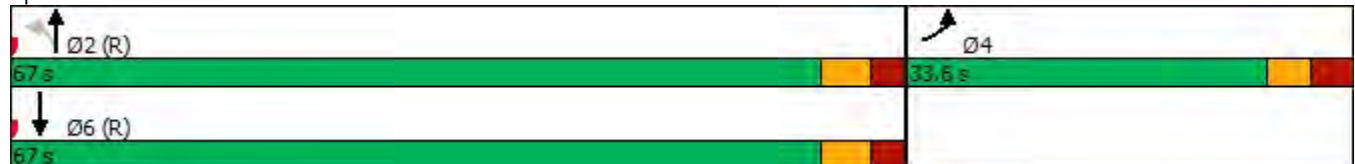

Intersection						
Int Delay, s/veh	0.6					
Movement	EBL	EBR	NBL	NBT	SBT	SBR
Lane Configurations		↗	↘	↑↑↑	↑↑↑	
Traffic Vol, veh/h	0	90	15	1746	948	84
Future Vol, veh/h	0	90	15	1746	948	84
Conflicting Peds, #/hr	20	20	20	0	0	20
Sign Control	Stop	Stop	Free	Free	Free	Free
RT Channelized	-	None	-	None	-	None
Storage Length	-	0	50	-	-	-
Veh in Median Storage, #	0	-	-	0	0	-
Grade, %	0	-	-	0	0	-
Peak Hour Factor	100	100	100	100	100	100
Heavy Vehicles, %	2	2	2	2	2	2
Mvmt Flow	0	90	15	1746	948	84

Major/Minor	Minor2	Major1	Major2		
Conflicting Flow All	-	556	1052	0	-
Stage 1	-	-	-	-	-
Stage 2	-	-	-	-	-
Critical Hdwy	-	7.14	5.34	-	-
Critical Hdwy Stg 1	-	-	-	-	-
Critical Hdwy Stg 2	-	-	-	-	-
Follow-up Hdwy	-	3.92	3.12	-	-
Pot Cap-1 Maneuver	0	406	369	-	-
Stage 1	0	-	-	-	-
Stage 2	0	-	-	-	-
Platoon blocked, %				-	-
Mov Cap-1 Maneuver	-	388	359	-	-
Mov Cap-2 Maneuver	-	-	-	-	-
Stage 1	-	-	-	-	-
Stage 2	-	-	-	-	-

Approach	EB	NB	SB
HCM Control Delay, s	17.1	0.1	0
HCM LOS	C		

Minor Lane/Major Mvmt	NBL	NBT	EBLn1	SBT	SBR
Capacity (veh/h)	359	-	388	-	-
HCM Lane V/C Ratio	0.042	-	0.232	-	-
HCM Control Delay (s)	15.5	-	17.1	-	-
HCM Lane LOS	C	-	C	-	-
HCM 95th %tile Q(veh)	0.1	-	0.9	-	-

Intersection						
Int Delay, s/veh	1.2					
Movement	WBL	WBR	NBT	NBR	SBL	SBT
Lane Configurations		↑↑↑	↑↑↑		↑	↑↑
Traffic Vol, veh/h	0	6	1760	21	72	967
Future Vol, veh/h	0	6	1760	21	72	967
Conflicting Peds, #/hr	0	0	0	0	0	0
Sign Control	Stop	Stop	Free	Free	Free	Free
RT Channelized	-	None	-	None	-	None
Storage Length	-	0	-	-	0	-
Veh in Median Storage, #	0	-	0	-	-	0
Grade, %	0	-	0	-	-	0
Peak Hour Factor	100	100	100	100	100	100
Heavy Vehicles, %	2	2	2	2	2	2
Mvmt Flow	0	6	1760	21	72	967

Major/Minor	Minor1	Major1	Major2
Conflicting Flow All	-	891	0 0 1781 0
Stage 1	-	-	- - - -
Stage 2	-	-	- - - -
Critical Hdwy	-	7.14	- - 5.34 -
Critical Hdwy Stg 1	-	-	- - - -
Critical Hdwy Stg 2	-	-	- - - -
Follow-up Hdwy	-	3.92	- - 3.12 -
Pot Cap-1 Maneuver	0	245	- - 161 -
Stage 1	0	-	- - - -
Stage 2	0	-	- - - -
Platoon blocked, %			- - - -
Mov Cap-1 Maneuver	-	245	- - 161 -
Mov Cap-2 Maneuver	-	-	- - - -
Stage 1	-	-	- - - -
Stage 2	-	-	- - - -

Approach	WB	NB	SB
HCM Control Delay, s	20.1	0	3.1
HCM LOS	C		

Minor Lane/Major Mvmt	NBT	NBRWBLn1	SBL	SBT
Capacity (veh/h)	-	-	245	161
HCM Lane V/C Ratio	-	-	0.024	0.447
HCM Control Delay (s)	-	-	20.1	44.3
HCM Lane LOS	-	-	C	E
HCM 95th %tile Q(veh)	-	-	0.1	2

Intersection						
Int Delay, s/veh	0.1					
Movement	WBL	WBR	NBT	NBR	SBL	SBT
Lane Configurations		↑ ↑ ↑	↑ ↑ ↑			↑ ↑ ↑
Traffic Vol, veh/h	0	9	1752	14	0	1039
Future Vol, veh/h	0	9	1752	14	0	1039
Conflicting Peds, #/hr	0	0	0	0	0	0
Sign Control	Stop	Stop	Free	Free	Free	Free
RT Channelized	-	None	-	None	-	None
Storage Length	-	0	-	-	-	-
Veh in Median Storage, #	0	-	0	-	-	0
Grade, %	0	-	0	-	-	0
Peak Hour Factor	100	100	100	100	100	100
Heavy Vehicles, %	2	2	2	2	2	2
Mvmt Flow	0	9	1752	14	0	1039

Major/Minor	Minor1	Major1	Major2		
Conflicting Flow All	-	883	0	0	-
Stage 1	-	-	-	-	-
Stage 2	-	-	-	-	-
Critical Hdwy	-	7.14	-	-	-
Critical Hdwy Stg 1	-	-	-	-	-
Critical Hdwy Stg 2	-	-	-	-	-
Follow-up Hdwy	-	3.92	-	-	-
Pot Cap-1 Maneuver	0	248	-	-	0
Stage 1	0	-	-	-	0
Stage 2	0	-	-	-	0
Platoon blocked, %			-	-	-
Mov Cap-1 Maneuver	-	248	-	-	-
Mov Cap-2 Maneuver	-	-	-	-	-
Stage 1	-	-	-	-	-
Stage 2	-	-	-	-	-

Approach	WB	NB	SB
HCM Control Delay, s	20.1	0	0
HCM LOS	C		

Minor Lane/Major Mvmt	NBT	NBRWBLn1	SBT
Capacity (veh/h)	-	-	248
HCM Lane V/C Ratio	-	-	0.036
HCM Control Delay (s)	-	-	20.1
HCM Lane LOS	-	-	C
HCM 95th %tile Q(veh)	-	-	0.1

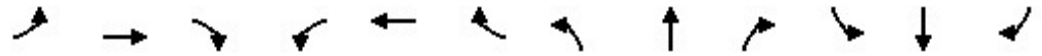

Lane Group	EBL	EBT	EBR	WBL	WBT	WBR	NBL	NBT	NBR	SBL	SBT	SBR
Lane Configurations	↖↗	↕	↖	↖↗	↕	↖	↖	↕	↖	↖↗	↕	↖
Traffic Volume (vph)	103	1082	57	620	1242	344	62	478	789	451	814	117
Future Volume (vph)	103	1082	57	620	1242	344	62	478	789	451	814	117
Ideal Flow (vphpl)	1800	1800	1800	1800	1800	1800	1800	1800	1800	1800	1800	1800
Lane Width (m)	3.7	3.5	4.8	3.7	3.5	3.7	3.7	3.5	4.8	3.7	3.5	3.5
Storage Length (m)	125.0		150.0	150.0		100.0	50.0		0.0	125.0		200.0
Storage Lanes	2		1	2		1	1		1	2		1
Taper Length (m)	7.6			7.6			7.6			7.6		
Lane Util. Factor	0.97	0.95	1.00	0.97	0.95	1.00	1.00	0.95	1.00	0.97	0.95	1.00
Ped Bike Factor	1.00		0.98	1.00		0.98	1.00		0.98	1.00		0.98
Fr _t			0.850			0.850			0.850			0.850
Fl _t Protected	0.950			0.950			0.950			0.950		
Satd. Flow (prot)	3288	3283	1651	3321	3252	1488	1729	3316	1717	3195	3349	1455
Fl _t Permitted	0.950			0.950			0.950			0.950		
Satd. Flow (perm)	3286	3283	1626	3318	3252	1464	1727	3316	1690	3184	3349	1432
Right Turn on Red			Yes			Yes			Yes			Yes
Satd. Flow (RTOR)			218			344			218			170
Link Speed (k/h)		80			80			60				60
Link Distance (m)		187.8			279.7			97.7				205.8
Travel Time (s)		8.5			12.6			5.9				12.3
Confl. Peds. (#/hr)	2		2	2		2	2		2	2		2
Peak Hour Factor	1.00	1.00	1.00	1.00	1.00	1.00	1.00	1.00	1.00	1.00	1.00	1.00
Heavy Vehicles (%)	2%	3%	5%	1%	4%	4%	0%	2%	1%	5%	1%	4%
Adj. Flow (vph)	103	1082	57	620	1242	344	62	478	789	451	814	117
Shared Lane Traffic (%)												
Lane Group Flow (vph)	103	1082	57	620	1242	344	62	478	789	451	814	117
Turn Type	Prot	NA	Perm	Prot	NA	Perm	Prot	NA	Perm	Prot	NA	Perm
Protected Phases	5	2		1	6		7	4		3	8	
Permitted Phases			2			6			4			8
Detector Phase	5	2	2	1	6	6	7	4	4	3	8	8
Switch Phase												
Minimum Initial (s)	5.0	5.0	5.0	5.0	5.0	5.0	5.0	5.0	5.0	5.0	5.0	5.0
Minimum Split (s)	11.6	30.6	30.6	11.6	31.6	31.6	11.6	30.6	30.6	11.6	31.6	31.6
Total Split (s)	15.0	63.0	63.0	28.0	76.0	76.0	13.0	31.0	31.0	28.0	46.0	46.0
Total Split (%)	10.0%	42.0%	42.0%	18.7%	50.7%	50.7%	8.7%	20.7%	20.7%	18.7%	30.7%	30.7%
Maximum Green (s)	8.4	56.4	56.4	21.4	69.4	69.4	6.4	24.4	24.4	21.4	39.4	39.4
Yellow Time (s)	3.7	3.7	3.7	3.7	3.7	3.7	3.7	3.7	3.7	3.7	3.7	3.7
All-Red Time (s)	2.9	2.9	2.9	2.9	2.9	2.9	2.9	2.9	2.9	2.9	2.9	2.9
Lost Time Adjust (s)	0.0	0.0	0.0	0.0	0.0	0.0	0.0	0.0	0.0	0.0	0.0	0.0
Total Lost Time (s)	6.6	6.6	6.6	6.6	6.6	6.6	6.6	6.6	6.6	6.6	6.6	6.6
Lead/Lag	Lead	Lag	Lag	Lead	Lag	Lag	Lead	Lag	Lag	Lead	Lag	Lag
Lead-Lag Optimize?	Yes	Yes	Yes	Yes	Yes	Yes	Yes	Yes	Yes	Yes	Yes	Yes
Vehicle Extension (s)	3.0	3.0	3.0	3.0	3.0	3.0	3.0	3.0	3.0	3.0	3.0	3.0
Recall Mode	None	C-Max	C-Max	None	C-Max	C-Max	None	Max	Max	None	Max	Max
Walk Time (s)		7.0	7.0		7.0	7.0		7.0	7.0		7.0	7.0
Flash Dont Walk (s)		17.0	17.0		18.0	18.0		17.0	17.0		18.0	18.0
Pedestrian Calls (#/hr)		2	2		2	2		2	2		2	2
Act Effct Green (s)	8.2	56.4	56.4	21.4	69.6	69.6	6.4	24.4	24.4	21.4	39.4	39.4
Actuated g/C Ratio	0.05	0.38	0.38	0.14	0.46	0.46	0.04	0.16	0.16	0.14	0.26	0.26



Lane Group	EBL	EBT	EBR	WBL	WBT	WBR	NBL	NBT	NBR	SBL	SBT	SBR
v/c Ratio	0.58	0.88	0.08	1.31	0.82	0.40	0.85	0.89	1.73	0.99	0.93	0.23
Control Delay	82.3	52.9	0.2	202.6	40.6	3.6	138.5	80.4	361.7	103.3	70.8	2.1
Queue Delay	0.0	0.0	0.0	0.0	0.0	0.0	0.0	0.0	0.0	0.0	0.0	0.0
Total Delay	82.3	52.9	0.2	202.6	40.6	3.6	138.5	80.4	361.7	103.3	70.8	2.1
LOS	F	D	A	F	D	A	F	F	F	F	E	A
Approach Delay		52.9			80.4			250.1			75.6	
Approach LOS		D			F			F			E	
Queue Length 50th (m)	14.4	144.7	0.0	~112.1	153.4	0.0	17.2	68.3	~267.5	64.5	115.1	0.0
Queue Length 95th (m)	23.9	172.2	0.0	#147.0	181.3	15.6	#43.2	#95.4	#339.5	#97.2	#149.5	2.9
Internal Link Dist (m)		163.8			255.7			73.7			181.8	
Turn Bay Length (m)	125.0		150.0	150.0		100.0	50.0		125.0			200.0
Base Capacity (vph)	184	1234	747	473	1509	864	73	539	457	455	879	501
Starvation Cap Reductn	0	0	0	0	0	0	0	0	0	0	0	0
Spillback Cap Reductn	0	0	0	0	0	0	0	0	0	0	0	0
Storage Cap Reductn	0	0	0	0	0	0	0	0	0	0	0	0
Reduced v/c Ratio	0.56	0.88	0.08	1.31	0.82	0.40	0.85	0.89	1.73	0.99	0.93	0.23

Intersection Summary

Area Type: Other
 Cycle Length: 150
 Actuated Cycle Length: 150
 Offset: 31 (21%), Referenced to phase 2:EBT and 6:WBT, Start of Green
 Natural Cycle: 150
 Control Type: Actuated-Coordinated
 Maximum v/c Ratio: 1.73
 Intersection Signal Delay: 110.4 Intersection LOS: F
 Intersection Capacity Utilization 113.4% ICU Level of Service H
 Analysis Period (min) 15
 ~ Volume exceeds capacity, queue is theoretically infinite.
 Queue shown is maximum after two cycles.
 # 95th percentile volume exceeds capacity, queue may be longer.
 Queue shown is maximum after two cycles.

Splits and Phases: 3: Prince of Wales Drive & West Hunt Club Road/Hunt Club Road

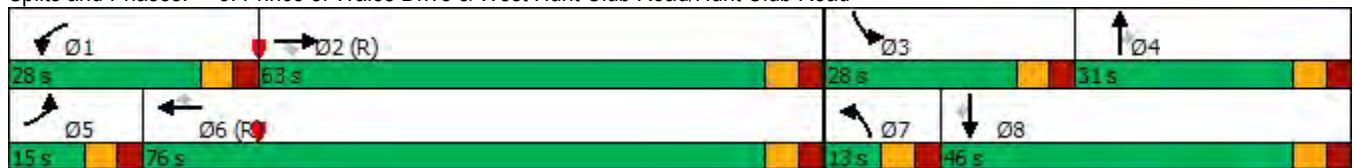

Lanes, Volumes, Timings
7: Prince of Wales Drive & Deakin Street

2175 Prince of Wales - 2025 PM - office 80000 sqft

03/01/2024



Lane Group	EBL	EBR	NBL	NBT	SBT	SBR
Lane Configurations						
Traffic Volume (vph)	468	187	34	779	1339	176
Future Volume (vph)	468	187	34	779	1339	176
Ideal Flow (vphpl)	1800	1800	1800	1800	1800	1800
Storage Length (m)	70.0	0.0	100.0			0.0
Storage Lanes	1	0	1			0
Taper Length (m)	7.6		7.6			
Lane Util. Factor	0.97	0.95	1.00	0.95	0.95	0.95
Ped Bike Factor	0.95				0.99	
Fr _t	0.957				0.983	
Fl _t Protected	0.966		0.950			
Satd. Flow (prot)	3122	0	1729	3390	3317	0
Fl _t Permitted	0.966		0.119			
Satd. Flow (perm)	3033	0	217	3390	3317	0
Right Turn on Red		Yes				Yes
Satd. Flow (RTOR)	48				26	
Link Speed (k/h)	50			60	60	
Link Distance (m)	195.1			117.9	111.9	
Travel Time (s)	14.0			7.1	6.7	
Confl. Peds. (#/hr)	20	20	20			20
Peak Hour Factor	1.00	1.00	1.00	1.00	1.00	1.00
Heavy Vehicles (%)	2%	2%	0%	2%	1%	5%
Adj. Flow (vph)	468	187	34	779	1339	176
Shared Lane Traffic (%)						
Lane Group Flow (vph)	655	0	34	779	1515	0
Turn Type	Prot		Perm	NA	NA	
Protected Phases	4			2	6	
Permitted Phases			2			
Detector Phase	4		2	2	6	
Switch Phase						
Minimum Initial (s)	5.0		5.0	5.0	5.0	
Minimum Split (s)	24.6		24.4	24.4	24.4	
Total Split (s)	33.0		87.0	87.0	87.0	
Total Split (%)	27.5%		72.5%	72.5%	72.5%	
Maximum Green (s)	26.4		80.6	80.6	80.6	
Yellow Time (s)	3.3		3.7	3.7	3.7	
All-Red Time (s)	3.3		2.7	2.7	2.7	
Lost Time Adjust (s)	0.0		0.0	0.0	0.0	
Total Lost Time (s)	6.6		6.4	6.4	6.4	
Lead/Lag						
Lead-Lag Optimize?						
Vehicle Extension (s)	3.0		3.0	3.0	3.0	
Recall Mode	None		C-Max	C-Max	C-Max	
Walk Time (s)	7.0		7.0	7.0	7.0	
Flash Dont Walk (s)	11.0		11.0	11.0	11.0	
Pedestrian Calls (#/hr)	0		0	0	0	
Act Effct Green (s)	25.8		81.2	81.2	81.2	
Actuated g/C Ratio	0.22		0.68	0.68	0.68	
v/c Ratio	0.93		0.23	0.34	0.67	



Lane Group	EBL	EBR	NBL	NBT	SBT	SBR
Control Delay	62.7		12.5	8.7	13.3	
Queue Delay	0.0		0.0	0.0	0.0	
Total Delay	62.7		12.5	8.7	13.3	
LOS	E		B	A	B	
Approach Delay	62.7			8.9	13.3	
Approach LOS	E			A	B	
Queue Length 50th (m)	67.1		2.6	34.5	93.4	
Queue Length 95th (m)	#96.9		7.9	43.6	114.1	
Internal Link Dist (m)	171.1			93.9	87.9	
Turn Bay Length (m)	70.0		100.0			
Base Capacity (vph)	724		146	2294	2253	
Starvation Cap Reductn	0		0	0	0	
Spillback Cap Reductn	0		0	0	0	
Storage Cap Reductn	0		0	0	0	
Reduced v/c Ratio	0.90		0.23	0.34	0.67	

Intersection Summary

Area Type: Other
 Cycle Length: 120
 Actuated Cycle Length: 120
 Offset: 0 (0%), Referenced to phase 2:NBT and 6:SBT, Start of Green
 Natural Cycle: 60
 Control Type: Actuated-Coordinated
 Maximum v/c Ratio: 0.93
 Intersection Signal Delay: 22.9
 Intersection LOS: C
 Intersection Capacity Utilization 76.9%
 ICU Level of Service D
 Analysis Period (min) 15
 # 95th percentile volume exceeds capacity, queue may be longer.
 Queue shown is maximum after two cycles.

Splits and Phases: 7: Prince of Wales Drive & Deakin Street

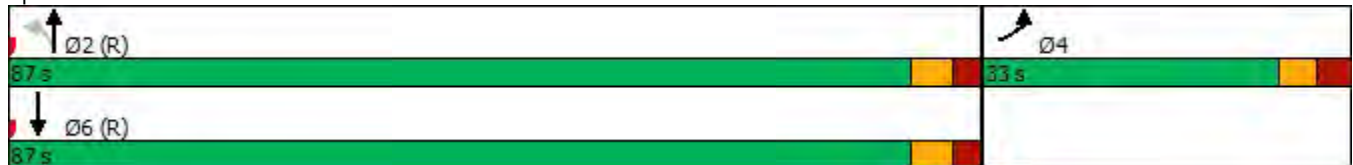

Intersection						
Int Delay, s/veh	0.3					
Movement	EBL	EBR	NBL	NBT	SBT	SBR
Lane Configurations		↗	↘	↑↑↑	↑↑↑	
Traffic Vol, veh/h	0	36	6	1329	1491	32
Future Vol, veh/h	0	36	6	1329	1491	32
Conflicting Peds, #/hr	20	20	20	0	0	20
Sign Control	Stop	Stop	Free	Free	Free	Free
RT Channelized	-	None	-	None	-	None
Storage Length	-	0	50	-	-	-
Veh in Median Storage, #	0	-	-	0	0	-
Grade, %	0	-	-	0	0	-
Peak Hour Factor	100	100	100	100	100	100
Heavy Vehicles, %	2	2	2	2	2	2
Mvmt Flow	0	36	6	1329	1491	32

Major/Minor	Minor2	Major1	Major2			
Conflicting Flow All	-	802	1543	0	-	0
Stage 1	-	-	-	-	-	-
Stage 2	-	-	-	-	-	-
Critical Hdwy	-	7.14	5.34	-	-	-
Critical Hdwy Stg 1	-	-	-	-	-	-
Critical Hdwy Stg 2	-	-	-	-	-	-
Follow-up Hdwy	-	3.92	3.12	-	-	-
Pot Cap-1 Maneuver	0	281	212	-	-	-
Stage 1	0	-	-	-	-	-
Stage 2	0	-	-	-	-	-
Platoon blocked, %				-	-	-
Mov Cap-1 Maneuver	-	268	206	-	-	-
Mov Cap-2 Maneuver	-	-	-	-	-	-
Stage 1	-	-	-	-	-	-
Stage 2	-	-	-	-	-	-

Approach	EB	NB	SB
HCM Control Delay, s	20.5	0.1	0
HCM LOS	C		

Minor Lane/Major Mvmt	NBL	NBT	EBLn1	SBT	SBR
Capacity (veh/h)	206	-	268	-	-
HCM Lane V/C Ratio	0.029	-	0.134	-	-
HCM Control Delay (s)	23	-	20.5	-	-
HCM Lane LOS	C	-	C	-	-
HCM 95th %tile Q(veh)	0.1	-	0.5	-	-

Intersection						
Int Delay, s/veh	0.3					
Movement	WBL	WBR	NBT	NBR	SBL	SBT
Lane Configurations		↗ ↑↑↑	↗ ↑↑↑		↘ ↑↑	↘ ↑↑
Traffic Vol, veh/h	0	38	1243	4	13	1515
Future Vol, veh/h	0	38	1243	4	13	1515
Conflicting Peds, #/hr	0	0	0	0	0	0
Sign Control	Stop	Stop	Free	Free	Free	Free
RT Channelized	-	None	-	None	-	None
Storage Length	-	0	-	-	0	-
Veh in Median Storage, #	0	-	0	-	-	0
Grade, %	0	-	0	-	-	0
Peak Hour Factor	100	100	100	100	100	100
Heavy Vehicles, %	2	2	2	2	2	2
Mvmt Flow	0	38	1243	4	13	1515

Major/Minor	Minor1	Major1	Major2
Conflicting Flow All	-	624	0 0 1247 0
Stage 1	-	-	- - - -
Stage 2	-	-	- - - -
Critical Hdwy	-	7.14	- - 5.34 -
Critical Hdwy Stg 1	-	-	- - - -
Critical Hdwy Stg 2	-	-	- - - -
Follow-up Hdwy	-	3.92	- - 3.12 -
Pot Cap-1 Maneuver	0	367	- - 297 -
Stage 1	0	-	- - - -
Stage 2	0	-	- - - -
Platoon blocked, %			- - - -
Mov Cap-1 Maneuver	-	367	- - 297 -
Mov Cap-2 Maneuver	-	-	- - - -
Stage 1	-	-	- - - -
Stage 2	-	-	- - - -

Approach	WB	NB	SB
HCM Control Delay, s	15.9	0	0.2
HCM LOS	C		

Minor Lane/Major Mvmt	NBT	NBRWBLn1	SBL	SBT
Capacity (veh/h)	-	-	367	297
HCM Lane V/C Ratio	-	-	0.104	0.044
HCM Control Delay (s)	-	-	15.9	17.7
HCM Lane LOS	-	-	C	C
HCM 95th %tile Q(veh)	-	-	0.3	0.1

Intersection						
Int Delay, s/veh	0.3					
Movement	WBL	WBR	NBT	NBR	SBL	SBT
Lane Configurations		↑ ↑ ↑	↑ ↑ ↑			↑ ↑ ↑
Traffic Vol, veh/h	0	57	1278	3	0	1528
Future Vol, veh/h	0	57	1278	3	0	1528
Conflicting Peds, #/hr	0	0	0	0	0	0
Sign Control	Stop	Stop	Free	Free	Free	Free
RT Channelized	-	None	-	None	-	None
Storage Length	-	0	-	-	-	-
Veh in Median Storage, #	0	-	0	-	-	0
Grade, %	0	-	0	-	-	0
Peak Hour Factor	100	100	100	100	100	100
Heavy Vehicles, %	2	2	2	2	2	2
Mvmt Flow	0	57	1278	3	0	1528

Major/Minor	Minor1	Major1	Major2
Conflicting Flow All	-	641	0
Stage 1	-	-	-
Stage 2	-	-	-
Critical Hdwy	-	7.14	-
Critical Hdwy Stg 1	-	-	-
Critical Hdwy Stg 2	-	-	-
Follow-up Hdwy	-	3.92	-
Pot Cap-1 Maneuver	0	358	-
Stage 1	0	-	-
Stage 2	0	-	-
Platoon blocked, %	-	-	-
Mov Cap-1 Maneuver	-	358	-
Mov Cap-2 Maneuver	-	-	-
Stage 1	-	-	-
Stage 2	-	-	-

Approach	WB	NB	SB
HCM Control Delay, s	17	0	0
HCM LOS	C		

Minor Lane/Major Mvmt	NBT	NBRWBLn1	SBT
Capacity (veh/h)	-	-	358
HCM Lane V/C Ratio	-	-	0.159
HCM Control Delay (s)	-	-	17
HCM Lane LOS	-	-	C
HCM 95th %tile Q(veh)	-	-	0.6

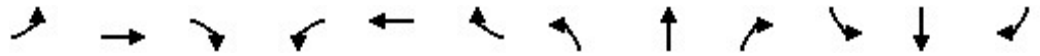

Lane Group	EBL	EBT	EBR	WBL	WBT	WBR	NBL	NBT	NBR	SBL	SBT	SBR
Lane Configurations	↕↕	↕↕	↕	↕↕	↕↕	↕	↕	↕↕	↕	↕↕	↕↕	↕
Traffic Volume (vph)	89	863	10	585	1133	462	73	754	960	291	456	215
Future Volume (vph)	89	863	10	585	1133	462	73	754	960	291	456	215
Ideal Flow (vphpl)	1800	1800	1800	1800	1800	1800	1800	1800	1800	1800	1800	1800
Lane Width (m)	3.7	3.5	4.8	3.7	3.5	3.7	3.7	3.5	4.8	3.7	3.5	3.5
Storage Length (m)	125.0		150.0	150.0		100.0	50.0		0.0	125.0		200.0
Storage Lanes	2		1	2		1	1		1	2		1
Taper Length (m)	7.6			7.6			7.6			7.6		
Lane Util. Factor	0.97	0.95	1.00	0.97	0.95	1.00	1.00	0.95	1.00	0.97	0.95	1.00
Ped Bike Factor	1.00		0.98	1.00		0.98	1.00		0.98	1.00		0.98
Fr _t			0.850			0.850			0.850			0.850
Fl _t Protected	0.950			0.950			0.950			0.950		
Satd. Flow (prot)	3022	3161	1535	3225	3252	1488	1662	3349	1683	3195	3221	1427
Fl _t Permitted	0.950			0.950			0.950			0.950		
Satd. Flow (perm)	3020	3161	1511	3222	3252	1465	1660	3349	1658	3188	3221	1405
Right Turn on Red			Yes			Yes			Yes			Yes
Satd. Flow (RTOR)			182			270			246			205
Link Speed (k/h)		80			80			60				60
Link Distance (m)		187.8			279.7			97.7				205.8
Travel Time (s)		8.5			12.6			5.9				12.3
Confl. Peds. (#/hr)	2		2	2		2	2		2	2		2
Peak Hour Factor	1.00	1.00	1.00	1.00	1.00	1.00	1.00	1.00	1.00	1.00	1.00	1.00
Heavy Vehicles (%)	11%	7%	13%	4%	4%	4%	4%	1%	3%	5%	5%	6%
Adj. Flow (vph)	89	863	10	585	1133	462	73	754	960	291	456	215
Shared Lane Traffic (%)												
Lane Group Flow (vph)	89	863	10	585	1133	462	73	754	960	291	456	215
Turn Type	Prot	NA	Perm	Prot	NA	Perm	Prot	NA	Perm	Prot	NA	Perm
Protected Phases	5	2		1	6		7	4		3	8	
Permitted Phases			2			6			4			8
Detector Phase	5	2	2	1	6	6	7	4	4	3	8	8
Switch Phase												
Minimum Initial (s)	1.0	1.0	1.0	1.0	1.0	1.0	1.0	1.0	1.0	1.0	1.0	1.0
Minimum Split (s)	11.6	31.8	31.8	11.6	34.2	34.2	11.6	31.6	31.6	11.6	31.6	31.6
Total Split (s)	16.0	48.0	48.0	28.0	60.0	60.0	20.0	44.0	44.0	20.0	44.0	44.0
Total Split (%)	11.4%	34.3%	34.3%	20.0%	42.9%	42.9%	14.3%	31.4%	31.4%	14.3%	31.4%	31.4%
Maximum Green (s)	9.4	41.2	41.2	21.4	53.2	53.2	13.4	37.4	37.4	13.4	37.4	37.4
Yellow Time (s)	3.7	4.6	4.6	3.7	4.6	4.6	3.7	3.7	3.7	3.7	3.7	3.7
All-Red Time (s)	2.9	2.2	2.2	2.9	2.2	2.2	2.9	2.9	2.9	2.9	2.9	2.9
Lost Time Adjust (s)	0.0	0.0	0.0	0.0	0.0	0.0	0.0	0.0	0.0	0.0	0.0	0.0
Total Lost Time (s)	6.6	6.8	6.8	6.6	6.8	6.8	6.6	6.6	6.6	6.6	6.6	6.6
Lead/Lag	Lead	Lag	Lag	Lead	Lag	Lag	Lead	Lag	Lag	Lead	Lag	Lag
Lead-Lag Optimize?	Yes	Yes	Yes	Yes	Yes	Yes	Yes	Yes	Yes	Yes	Yes	Yes
Vehicle Extension (s)	3.0	3.0	3.0	3.0	3.0	3.0	3.0	3.0	3.0	3.0	3.0	3.0
Recall Mode	None	C-Max	C-Max	None	C-Max	C-Max	None	Max	Max	None	Max	Max
Walk Time (s)		7.0	7.0		7.0	7.0		7.0	7.0		7.0	7.0
Flash Dont Walk (s)		18.0	18.0		18.0	18.0		17.0	17.0		17.0	17.0
Pedestrian Calls (#/hr)		2	2		2	2		2	2		2	2
Act Effct Green (s)	8.7	41.2	41.2	21.4	53.9	53.9	11.0	37.4	37.4	13.4	42.5	42.5
Actuated g/C Ratio	0.06	0.29	0.29	0.15	0.38	0.38	0.08	0.27	0.27	0.10	0.30	0.30

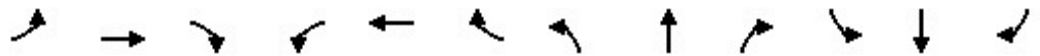

Lane Group	EBL	EBT	EBR	WBL	WBT	WBR	NBL	NBT	NBR	SBL	SBT	SBR
v/c Ratio	0.48	0.93	0.02	1.19	0.90	0.63	0.56	0.84	1.54	0.95	0.47	0.38
Control Delay	72.0	64.6	0.1	153.7	51.9	18.1	78.3	58.4	278.1	103.4	42.8	8.1
Queue Delay	0.0	0.0	0.0	0.0	0.0	0.0	0.0	0.0	0.0	0.0	0.0	0.0
Total Delay	72.0	64.6	0.1	153.7	51.9	18.1	78.3	58.4	278.1	103.4	42.8	8.1
LOS	E	E	A	F	D	B	E	E	F	F	D	A
Approach Delay		64.6			72.1			177.3			53.4	
Approach LOS		E			E			F			D	
Queue Length 50th (m)	11.4	112.8	0.0	~92.3	143.8	39.6	18.2	96.2	~296.6	38.7	51.5	1.9
Queue Length 95th (m)	19.8	#148.1	0.0	#125.8	#182.4	74.4	33.1	118.9	#369.6	#64.6	68.6	20.5
Internal Link Dist (m)		163.8			255.7			73.7			181.8	
Turn Bay Length (m)	125.0		150.0	150.0		100.0	50.0			125.0		200.0
Base Capacity (vph)	202	930	573	492	1252	730	159	894	623	305	978	569
Starvation Cap Reductn	0	0	0	0	0	0	0	0	0	0	0	0
Spillback Cap Reductn	0	0	0	0	0	0	0	0	0	0	0	0
Storage Cap Reductn	0	0	0	0	0	0	0	0	0	0	0	0
Reduced v/c Ratio	0.44	0.93	0.02	1.19	0.90	0.63	0.46	0.84	1.54	0.95	0.47	0.38

Intersection Summary

Area Type: Other
 Cycle Length: 140
 Actuated Cycle Length: 140
 Offset: 68 (49%), Referenced to phase 2:EBT and 6:WBT, Start of Green
 Natural Cycle: 150
 Control Type: Actuated-Coordinated
 Maximum v/c Ratio: 1.54
 Intersection Signal Delay: 99.7
 Intersection LOS: F
 Intersection Capacity Utilization 113.6%
 ICU Level of Service H
 Analysis Period (min) 15
 ~ Volume exceeds capacity, queue is theoretically infinite.
 Queue shown is maximum after two cycles.
 # 95th percentile volume exceeds capacity, queue may be longer.
 Queue shown is maximum after two cycles.

Splits and Phases: 3: Prince of Wales Drive & West Hunt Club Road/Hunt Club Road



Lanes, Volumes, Timings
7: Prince of Wales Drive & Deakin Street

2175 Prince of Wales - 2030 AM - office 80000 sqft

02/29/2024



Lane Group	EBL	EBR	NBL	NBT	SBT	SBR
Lane Configurations						
Traffic Volume (vph)	530	23	161	1294	576	413
Future Volume (vph)	530	23	161	1294	576	413
Ideal Flow (vphpl)	1800	1800	1800	1800	1800	1800
Storage Length (m)	70.0	0.0	100.0			0.0
Storage Lanes	1	0	1			0
Taper Length (m)	7.6		7.6			
Lane Util. Factor	0.97	0.95	1.00	0.95	0.95	0.95
Ped Bike Factor	1.00		1.00		0.99	
Frt	0.994				0.937	
Flt Protected	0.954		0.950			
Satd. Flow (prot)	3279	0	1695	3390	3144	0
Flt Permitted	0.954		0.255			
Satd. Flow (perm)	3272	0	455	3390	3144	0
Right Turn on Red		Yes				Yes
Satd. Flow (RTOR)	4				323	
Link Speed (k/h)	50			60	60	
Link Distance (m)	195.1			117.9	111.9	
Travel Time (s)	14.0			7.1	6.7	
Confl. Peds. (#/hr)	2	2	2			2
Peak Hour Factor	1.00	1.00	1.00	1.00	1.00	1.00
Adj. Flow (vph)	530	23	161	1294	576	413
Shared Lane Traffic (%)						
Lane Group Flow (vph)	553	0	161	1294	989	0
Turn Type	Prot		Perm	NA	NA	
Protected Phases	4			2	6	
Permitted Phases			2			
Detector Phase	4		2	2	6	
Switch Phase						
Minimum Initial (s)	1.0		5.0	5.0	5.0	
Minimum Split (s)	33.6		29.4	29.4	29.4	
Total Split (s)	33.6		67.0	67.0	67.0	
Total Split (%)	33.4%		66.6%	66.6%	66.6%	
Maximum Green (s)	27.0		60.6	60.6	60.6	
Yellow Time (s)	3.3		3.7	3.7	3.7	
All-Red Time (s)	3.3		2.7	2.7	2.7	
Lost Time Adjust (s)	0.0		0.0	0.0	0.0	
Total Lost Time (s)	6.6		6.4	6.4	6.4	
Lead/Lag						
Lead-Lag Optimize?						
Vehicle Extension (s)	3.0		3.0	3.0	3.0	
Recall Mode	None		C-Max	C-Max	C-Max	
Walk Time (s)	7.0		7.0	7.0	7.0	
Flash Dont Walk (s)	20.0		16.0	16.0	16.0	
Pedestrian Calls (#/hr)	2		2	2	2	
Act Effct Green (s)	21.9		65.7	65.7	65.7	
Actuated g/C Ratio	0.22		0.65	0.65	0.65	
v/c Ratio	0.77		0.54	0.58	0.46	
Control Delay	44.2		19.3	11.7	6.6	



Lane Group	EBL	EBR	NBL	NBT	SBT	SBR
Queue Delay	0.0		0.0	0.0	0.0	
Total Delay	44.2		19.3	11.7	6.6	
LOS	D		B	B	A	
Approach Delay	44.2			12.6	6.6	
Approach LOS	D			B	A	
Queue Length 50th (m)	48.0		14.1	62.1	26.0	
Queue Length 95th (m)	60.6		39.1	91.8	43.7	
Internal Link Dist (m)	171.1			93.9	87.9	
Turn Bay Length (m)	70.0		100.0			
Base Capacity (vph)	882		297	2213	2164	
Starvation Cap Reductn	0		0	0	0	
Spillback Cap Reductn	0		0	0	0	
Storage Cap Reductn	0		0	0	0	
Reduced v/c Ratio	0.63		0.54	0.58	0.46	

Intersection Summary

Area Type:	Other
Cycle Length:	100.6
Actuated Cycle Length:	100.6
Offset:	0 (0%), Referenced to phase 2:NBTL and 6:SBT, Start of Green
Natural Cycle:	80
Control Type:	Actuated-Coordinated
Maximum v/c Ratio:	0.77
Intersection Signal Delay:	16.4
Intersection LOS:	B
Intersection Capacity Utilization	73.6%
ICU Level of Service	D
Analysis Period (min)	15

Splits and Phases: 7: Prince of Wales Drive & Deakin Street

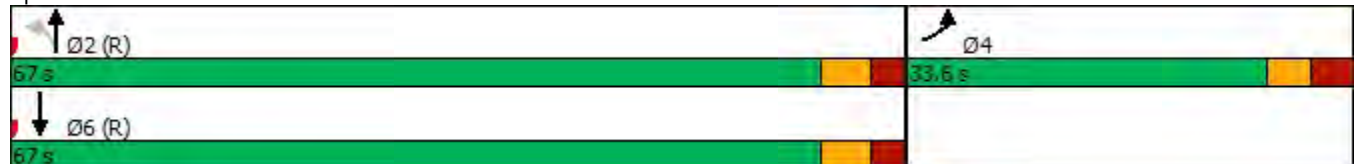

Intersection						
Int Delay, s/veh	0.6					
Movement	EBL	EBR	NBL	NBT	SBT	SBR
Lane Configurations		↗	↘	↑↑↑	↑↑↑	
Traffic Vol, veh/h	0	90	15	1789	969	84
Future Vol, veh/h	0	90	15	1789	969	84
Conflicting Peds, #/hr	20	20	20	0	0	20
Sign Control	Stop	Stop	Free	Free	Free	Free
RT Channelized	-	None	-	None	-	None
Storage Length	-	0	50	-	-	-
Veh in Median Storage, #	0	-	-	0	0	-
Grade, %	0	-	-	0	0	-
Peak Hour Factor	100	100	100	100	100	100
Heavy Vehicles, %	2	2	2	2	2	2
Mvmt Flow	0	90	15	1789	969	84

Major/Minor	Minor2	Major1	Major2		
Conflicting Flow All	-	567	1073	0	-
Stage 1	-	-	-	-	-
Stage 2	-	-	-	-	-
Critical Hdwy	-	7.14	5.34	-	-
Critical Hdwy Stg 1	-	-	-	-	-
Critical Hdwy Stg 2	-	-	-	-	-
Follow-up Hdwy	-	3.92	3.12	-	-
Pot Cap-1 Maneuver	0	400	361	-	-
Stage 1	0	-	-	-	-
Stage 2	0	-	-	-	-
Platoon blocked, %				-	-
Mov Cap-1 Maneuver	-	382	351	-	-
Mov Cap-2 Maneuver	-	-	-	-	-
Stage 1	-	-	-	-	-
Stage 2	-	-	-	-	-

Approach	EB	NB	SB
HCM Control Delay, s	17.3	0.1	0
HCM LOS	C		

Minor Lane/Major Mvmt	NBL	NBT	EBLn1	SBT	SBR
Capacity (veh/h)	351	-	382	-	-
HCM Lane V/C Ratio	0.043	-	0.236	-	-
HCM Control Delay (s)	15.7	-	17.3	-	-
HCM Lane LOS	C	-	C	-	-
HCM 95th %tile Q(veh)	0.1	-	0.9	-	-

Intersection						
Int Delay, s/veh	1.3					
Movement	WBL	WBR	NBT	NBR	SBL	SBT
Lane Configurations		↗ ↑↑↑	↗ ↑↑↑		↘ ↑↑	↘ ↑↑
Traffic Vol, veh/h	0	6	1804	21	72	985
Future Vol, veh/h	0	6	1804	21	72	985
Conflicting Peds, #/hr	0	0	0	0	0	0
Sign Control	Stop	Stop	Free	Free	Free	Free
RT Channelized	-	None	-	None	-	None
Storage Length	-	0	-	-	0	-
Veh in Median Storage, #	0	-	0	-	-	0
Grade, %	0	-	0	-	-	0
Peak Hour Factor	100	100	100	100	100	100
Heavy Vehicles, %	2	2	2	2	2	2
Mvmt Flow	0	6	1804	21	72	985

Major/Minor	Minor1	Major1	Major2		
Conflicting Flow All	-	913	0	0	1825
Stage 1	-	-	-	-	-
Stage 2	-	-	-	-	-
Critical Hdwy	-	7.14	-	-	5.34
Critical Hdwy Stg 1	-	-	-	-	-
Critical Hdwy Stg 2	-	-	-	-	-
Follow-up Hdwy	-	3.92	-	-	3.12
Pot Cap-1 Maneuver	0	237	-	-	153
Stage 1	0	-	-	-	-
Stage 2	0	-	-	-	-
Platoon blocked, %					
Mov Cap-1 Maneuver	-	237	-	-	153
Mov Cap-2 Maneuver	-	-	-	-	-
Stage 1	-	-	-	-	-
Stage 2	-	-	-	-	-

Approach	WB	NB	SB
HCM Control Delay, s	20.6	0	3.3
HCM LOS	C		

Minor Lane/Major Mvmt	NBT	NBRWBLn1	SBL	SBT
Capacity (veh/h)	-	-	237	153
HCM Lane V/C Ratio	-	-	0.025	0.471
HCM Control Delay (s)	-	-	20.6	47.9
HCM Lane LOS	-	-	C	E
HCM 95th %tile Q(veh)	-	-	0.1	2.2

Intersection						
Int Delay, s/veh	0.1					
Movement	WBL	WBR	NBT	NBR	SBL	SBT
Lane Configurations		↑ ↑ ↑	↑ ↑ ↑			↑ ↑ ↑
Traffic Vol, veh/h	0	9	1796	14	0	1057
Future Vol, veh/h	0	9	1796	14	0	1057
Conflicting Peds, #/hr	0	0	0	0	0	0
Sign Control	Stop	Stop	Free	Free	Free	Free
RT Channelized	-	None	-	None	-	None
Storage Length	-	0	-	-	-	-
Veh in Median Storage, #	0	-	0	-	-	0
Grade, %	0	-	0	-	-	0
Peak Hour Factor	100	100	100	100	100	100
Heavy Vehicles, %	2	2	2	2	2	2
Mvmt Flow	0	9	1796	14	0	1057

Major/Minor	Minor1	Major1	Major2		
Conflicting Flow All	-	905	0	0	-
Stage 1	-	-	-	-	-
Stage 2	-	-	-	-	-
Critical Hdwy	-	7.14	-	-	-
Critical Hdwy Stg 1	-	-	-	-	-
Critical Hdwy Stg 2	-	-	-	-	-
Follow-up Hdwy	-	3.92	-	-	-
Pot Cap-1 Maneuver	0	240	-	-	0
Stage 1	0	-	-	-	0
Stage 2	0	-	-	-	0
Platoon blocked, %			-	-	-
Mov Cap-1 Maneuver	-	240	-	-	-
Mov Cap-2 Maneuver	-	-	-	-	-
Stage 1	-	-	-	-	-
Stage 2	-	-	-	-	-

Approach	WB	NB	SB
HCM Control Delay, s	20.6	0	0
HCM LOS	C		

Minor Lane/Major Mvmt	NBT	NBRWBLn1	SBT
Capacity (veh/h)	-	-	240
HCM Lane V/C Ratio	-	-	0.038
HCM Control Delay (s)	-	-	20.6
HCM Lane LOS	-	-	C
HCM 95th %tile Q(veh)	-	-	0.1

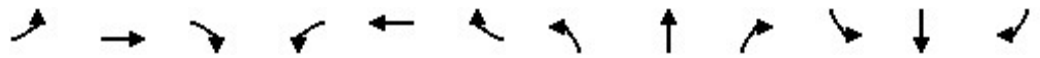

Lane Group	EBL	EBT	EBR	WBL	WBT	WBR	NBL	NBT	NBR	SBL	SBT	SBR
Lane Configurations	↖↖	↗↗	↘	↖↖	↗↗	↘	↖	↗↗	↘	↖↖	↗↗	↘
Traffic Volume (vph)	106	1108	58	635	1273	353	63	489	808	463	834	120
Future Volume (vph)	106	1108	58	635	1273	353	63	489	808	463	834	120
Ideal Flow (vphpl)	1800	1800	1800	1800	1800	1800	1800	1800	1800	1800	1800	1800
Lane Width (m)	3.7	3.5	4.8	3.7	3.5	3.7	3.7	3.5	4.8	3.7	3.5	3.5
Storage Length (m)	125.0		150.0	150.0		100.0	50.0		0.0	125.0		200.0
Storage Lanes	2		1	2		1	1		1	2		1
Taper Length (m)	7.6			7.6			7.6			7.6		
Lane Util. Factor	0.97	0.95	1.00	0.97	0.95	1.00	1.00	0.95	1.00	0.97	0.95	1.00
Ped Bike Factor	1.00		0.98	1.00		0.98	1.00		0.98	1.00		0.98
Fr _t			0.850			0.850			0.850			0.850
Fl _t Protected	0.950			0.950			0.950			0.950		
Satd. Flow (prot)	3288	3283	1651	3321	3252	1488	1729	3316	1717	3195	3349	1455
Fl _t Permitted	0.950			0.950			0.950			0.950		
Satd. Flow (perm)	3286	3283	1626	3318	3252	1464	1727	3316	1690	3184	3349	1432
Right Turn on Red			Yes			Yes			Yes			Yes
Satd. Flow (RTOR)			218			353			218			170
Link Speed (k/h)		80			80			60				60
Link Distance (m)		187.8			279.7			97.7				205.8
Travel Time (s)		8.5			12.6			5.9				12.3
Confl. Peds. (#/hr)	2		2	2		2	2		2	2		2
Peak Hour Factor	1.00	1.00	1.00	1.00	1.00	1.00	1.00	1.00	1.00	1.00	1.00	1.00
Heavy Vehicles (%)	2%	3%	5%	1%	4%	4%	0%	2%	1%	5%	1%	4%
Adj. Flow (vph)	106	1108	58	635	1273	353	63	489	808	463	834	120
Shared Lane Traffic (%)												
Lane Group Flow (vph)	106	1108	58	635	1273	353	63	489	808	463	834	120
Turn Type	Prot	NA	Perm	Prot	NA	Perm	Prot	NA	Perm	Prot	NA	Perm
Protected Phases	5	2		1	6		7	4		3	8	
Permitted Phases			2			6			4			8
Detector Phase	5	2	2	1	6	6	7	4	4	3	8	8
Switch Phase												
Minimum Initial (s)	5.0	5.0	5.0	5.0	5.0	5.0	5.0	5.0	5.0	5.0	5.0	5.0
Minimum Split (s)	11.6	30.6	30.6	11.6	31.6	31.6	11.6	30.6	30.6	11.6	31.6	31.6
Total Split (s)	15.0	63.0	63.0	28.0	76.0	76.0	13.0	31.0	31.0	28.0	46.0	46.0
Total Split (%)	10.0%	42.0%	42.0%	18.7%	50.7%	50.7%	8.7%	20.7%	20.7%	18.7%	30.7%	30.7%
Maximum Green (s)	8.4	56.4	56.4	21.4	69.4	69.4	6.4	24.4	24.4	21.4	39.4	39.4
Yellow Time (s)	3.7	3.7	3.7	3.7	3.7	3.7	3.7	3.7	3.7	3.7	3.7	3.7
All-Red Time (s)	2.9	2.9	2.9	2.9	2.9	2.9	2.9	2.9	2.9	2.9	2.9	2.9
Lost Time Adjust (s)	0.0	0.0	0.0	0.0	0.0	0.0	0.0	0.0	0.0	0.0	0.0	0.0
Total Lost Time (s)	6.6	6.6	6.6	6.6	6.6	6.6	6.6	6.6	6.6	6.6	6.6	6.6
Lead/Lag	Lead	Lag	Lag	Lead	Lag	Lag	Lead	Lag	Lag	Lead	Lag	Lag
Lead-Lag Optimize?	Yes	Yes	Yes	Yes	Yes	Yes	Yes	Yes	Yes	Yes	Yes	Yes
Vehicle Extension (s)	3.0	3.0	3.0	3.0	3.0	3.0	3.0	3.0	3.0	3.0	3.0	3.0
Recall Mode	None	C-Max	C-Max	None	C-Max	C-Max	None	Max	Max	None	Max	Max
Walk Time (s)		7.0	7.0		7.0	7.0		7.0	7.0		7.0	7.0
Flash Dont Walk (s)		17.0	17.0		18.0	18.0		17.0	17.0		18.0	18.0
Pedestrian Calls (#/hr)		2	2		2	2		2	2		2	2
Act Effct Green (s)	8.2	56.4	56.4	21.4	69.6	69.6	6.4	24.4	24.4	21.4	39.4	39.4
Actuated g/C Ratio	0.05	0.38	0.38	0.14	0.46	0.46	0.04	0.16	0.16	0.14	0.26	0.26



Lane Group	EBL	EBT	EBR	WBL	WBT	WBR	NBL	NBT	NBR	SBL	SBT	SBR
v/c Ratio	0.59	0.90	0.08	1.34	0.84	0.41	0.86	0.91	1.77	1.02	0.95	0.24
Control Delay	83.1	54.8	0.2	214.9	41.9	3.6	141.3	83.0	379.7	108.9	74.3	2.4
Queue Delay	0.0	0.0	0.0	0.0	0.0	0.0	0.0	0.0	0.0	0.0	0.0	0.0
Total Delay	83.1	54.8	0.2	214.9	41.9	3.6	141.3	83.0	379.7	108.9	74.3	2.4
LOS	F	D	A	F	D	A	F	F	F	F	E	A
Approach Delay		54.7			84.5			262.0			79.5	
Approach LOS		D			F			F			E	
Queue Length 50th (m)	14.8	149.9	0.0	~116.5	159.7	0.0	17.5	70.2	~278.5	~68.8	118.8	0.0
Queue Length 95th (m)	24.3	#179.1	0.0	#151.3	188.8	15.8	#43.8	#98.7	#350.4	#100.7	#155.5	3.5
Internal Link Dist (m)		163.8			255.7			73.7			181.8	
Turn Bay Length (m)	125.0		150.0	150.0		100.0	50.0			125.0		200.0
Base Capacity (vph)	184	1234	747	473	1509	869	73	539	457	455	879	501
Starvation Cap Reductn	0	0	0	0	0	0	0	0	0	0	0	0
Spillback Cap Reductn	0	0	0	0	0	0	0	0	0	0	0	0
Storage Cap Reductn	0	0	0	0	0	0	0	0	0	0	0	0
Reduced v/c Ratio	0.58	0.90	0.08	1.34	0.84	0.41	0.86	0.91	1.77	1.02	0.95	0.24

Intersection Summary

Area Type: Other
 Cycle Length: 150
 Actuated Cycle Length: 150
 Offset: 31 (21%), Referenced to phase 2:EBT and 6:WBT, Start of Green
 Natural Cycle: 150
 Control Type: Actuated-Coordinated
 Maximum v/c Ratio: 1.77
 Intersection Signal Delay: 115.6 Intersection LOS: F
 Intersection Capacity Utilization 115.8% ICU Level of Service H
 Analysis Period (min) 15
 ~ Volume exceeds capacity, queue is theoretically infinite.
 Queue shown is maximum after two cycles.
 # 95th percentile volume exceeds capacity, queue may be longer.
 Queue shown is maximum after two cycles.

Splits and Phases: 3: Prince of Wales Drive & West Hunt Club Road/Hunt Club Road

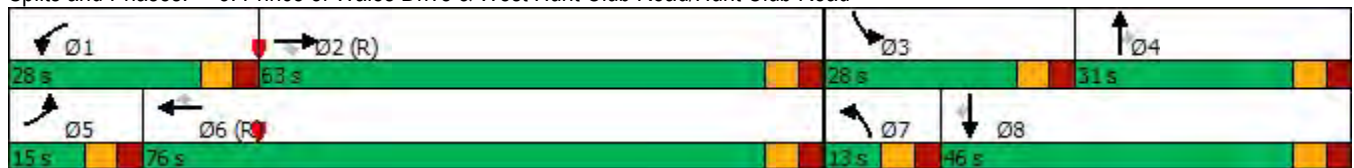

Lanes, Volumes, Timings
7: Prince of Wales Drive & Deakin Street

2175 Prince of Wales - 2030 PM - office 80000 sqft
03/01/2024



Lane Group	EBL	EBR	NBL	NBT	SBT	SBR
Lane Configurations						
Traffic Volume (vph)	479	191	35	798	1371	180
Future Volume (vph)	479	191	35	798	1371	180
Ideal Flow (vphpl)	1800	1800	1800	1800	1800	1800
Storage Length (m)	70.0	0.0	100.0			0.0
Storage Lanes	1	0	1			0
Taper Length (m)	7.6		7.6			
Lane Util. Factor	0.97	0.95	1.00	0.95	0.95	0.95
Ped Bike Factor	0.95				0.99	
Frt	0.957				0.983	
Flt Protected	0.965		0.950			
Satd. Flow (prot)	3119	0	1729	3390	3317	0
Flt Permitted	0.965		0.112			
Satd. Flow (perm)	3030	0	204	3390	3317	0
Right Turn on Red		Yes				Yes
Satd. Flow (RTOR)	48				26	
Link Speed (k/h)	50			60	60	
Link Distance (m)	195.1			117.9	111.9	
Travel Time (s)	14.0			7.1	6.7	
Confl. Peds. (#/hr)	20	20	20			20
Peak Hour Factor	1.00	1.00	1.00	1.00	1.00	1.00
Heavy Vehicles (%)	2%	2%	0%	2%	1%	5%
Adj. Flow (vph)	479	191	35	798	1371	180
Shared Lane Traffic (%)						
Lane Group Flow (vph)	670	0	35	798	1551	0
Turn Type	Prot		Perm	NA	NA	
Protected Phases	4			2	6	
Permitted Phases			2			
Detector Phase	4		2	2	6	
Switch Phase						
Minimum Initial (s)	5.0		5.0	5.0	5.0	
Minimum Split (s)	24.6		24.4	24.4	24.4	
Total Split (s)	33.0		87.0	87.0	87.0	
Total Split (%)	27.5%		72.5%	72.5%	72.5%	
Maximum Green (s)	26.4		80.6	80.6	80.6	
Yellow Time (s)	3.3		3.7	3.7	3.7	
All-Red Time (s)	3.3		2.7	2.7	2.7	
Lost Time Adjust (s)	0.0		0.0	0.0	0.0	
Total Lost Time (s)	6.6		6.4	6.4	6.4	
Lead/Lag						
Lead-Lag Optimize?						
Vehicle Extension (s)	3.0		3.0	3.0	3.0	
Recall Mode	None		C-Max	C-Max	C-Max	
Walk Time (s)	7.0		7.0	7.0	7.0	
Flash Dont Walk (s)	11.0		11.0	11.0	11.0	
Pedestrian Calls (#/hr)	0		0	0	0	
Act Effct Green (s)	26.0		81.0	81.0	81.0	
Actuated g/C Ratio	0.22		0.68	0.68	0.68	
v/c Ratio	0.94		0.25	0.35	0.69	

Lanes, Volumes, Timings
 7: Prince of Wales Drive & Deakin Street

2175 Prince of Wales - 2030 PM - office 80000 sqft
 03/01/2024



Lane Group	EBL	EBR	NBL	NBT	SBT	SBR
Control Delay	65.2		13.5	8.8	13.7	
Queue Delay	0.0		0.0	0.0	0.0	
Total Delay	65.2		13.5	8.8	13.7	
LOS	E		B	A	B	
Approach Delay	65.2			9.0	13.7	
Approach LOS	E			A	B	
Queue Length 50th (m)	69.2		2.7	35.7	97.7	
Queue Length 95th (m)	#100.8		8.4	44.9	119.4	
Internal Link Dist (m)	171.1			93.9	87.9	
Turn Bay Length (m)	70.0		100.0			
Base Capacity (vph)	723		138	2289	2248	
Starvation Cap Reductn	0		0	0	0	
Spillback Cap Reductn	0		0	0	0	
Storage Cap Reductn	0		0	0	0	
Reduced v/c Ratio	0.93		0.25	0.35	0.69	

Intersection Summary

Area Type: Other
 Cycle Length: 120
 Actuated Cycle Length: 120
 Offset: 0 (0%), Referenced to phase 2:NBTL and 6:SBT, Start of Green
 Natural Cycle: 65
 Control Type: Actuated-Coordinated
 Maximum v/c Ratio: 0.94
 Intersection Signal Delay: 23.7
 Intersection LOS: C
 Intersection Capacity Utilization 78.4%
 ICU Level of Service D
 Analysis Period (min) 15
 # 95th percentile volume exceeds capacity, queue may be longer.
 Queue shown is maximum after two cycles.

Splits and Phases: 7: Prince of Wales Drive & Deakin Street

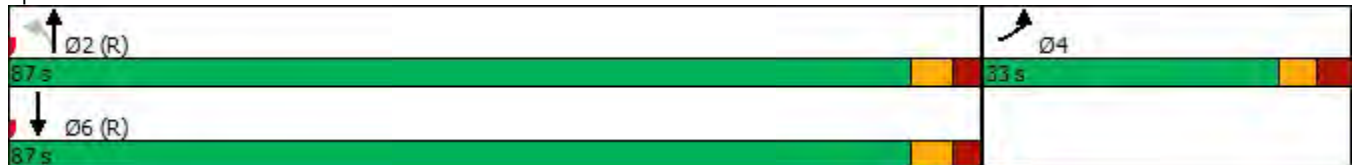

Intersection

Int Delay, s/veh 0.3

Movement	EBL	EBR	NBL	NBT	SBT	SBR
Lane Configurations		↗	↘	↑↑↑	↑↑↑	
Traffic Vol, veh/h	0	36	6	1360	1527	32
Future Vol, veh/h	0	36	6	1360	1527	32
Conflicting Peds, #/hr	20	20	20	0	0	20
Sign Control	Stop	Stop	Free	Free	Free	Free
RT Channelized	-	None	-	None	-	None
Storage Length	-	0	50	-	-	-
Veh in Median Storage, #	0	-	-	0	0	-
Grade, %	0	-	-	0	0	-
Peak Hour Factor	100	100	100	100	100	100
Heavy Vehicles, %	2	2	2	2	2	2
Mvmt Flow	0	36	6	1360	1527	32

Major/Minor	Minor2	Major1	Major2
Conflicting Flow All	-	820	1579
Stage 1	-	-	-
Stage 2	-	-	-
Critical Hdwy	-	7.14	5.34
Critical Hdwy Stg 1	-	-	-
Critical Hdwy Stg 2	-	-	-
Follow-up Hdwy	-	3.92	3.12
Pot Cap-1 Maneuver	0	273	204
Stage 1	0	-	-
Stage 2	0	-	-
Platoon blocked, %			
Mov Cap-1 Maneuver	-	261	198
Mov Cap-2 Maneuver	-	-	-
Stage 1	-	-	-
Stage 2	-	-	-

Approach	EB	NB	SB
HCM Control Delay, s	21	0.1	0
HCM LOS	C		

Minor Lane/Major Mvmt	NBL	NBT	EBLn1	SBT	SBR
Capacity (veh/h)	198	-	261	-	-
HCM Lane V/C Ratio	0.03	-	0.138	-	-
HCM Control Delay (s)	23.7	-	21	-	-
HCM Lane LOS	C	-	C	-	-
HCM 95th %tile Q(veh)	0.1	-	0.5	-	-

Intersection						
Int Delay, s/veh	0.3					
Movement	WBL	WBR	NBT	NBR	SBL	SBT
Lane Configurations		↗ ↑↑↑	↗ ↑↑↑		↘ ↑↑	↘ ↑↑
Traffic Vol, veh/h	0	38	1274	4	13	1519
Future Vol, veh/h	0	38	1274	4	13	1519
Conflicting Peds, #/hr	0	0	0	0	0	0
Sign Control	Stop	Stop	Free	Free	Free	Free
RT Channelized	-	None	-	None	-	None
Storage Length	-	0	-	-	0	-
Veh in Median Storage, #	0	-	0	-	-	0
Grade, %	0	-	0	-	-	0
Peak Hour Factor	100	100	100	100	100	100
Heavy Vehicles, %	2	2	2	2	2	2
Mvmt Flow	0	38	1274	4	13	1519

Major/Minor	Minor1	Major1	Major2		
Conflicting Flow All	-	639	0	0	1278
Stage 1	-	-	-	-	-
Stage 2	-	-	-	-	-
Critical Hdwy	-	7.14	-	-	5.34
Critical Hdwy Stg 1	-	-	-	-	-
Critical Hdwy Stg 2	-	-	-	-	-
Follow-up Hdwy	-	3.92	-	-	3.12
Pot Cap-1 Maneuver	0	359	-	-	287
Stage 1	0	-	-	-	-
Stage 2	0	-	-	-	-
Platoon blocked, %					
Mov Cap-1 Maneuver	-	359	-	-	287
Mov Cap-2 Maneuver	-	-	-	-	-
Stage 1	-	-	-	-	-
Stage 2	-	-	-	-	-

Approach	WB	NB	SB
HCM Control Delay, s	16.2	0	0.2
HCM LOS	C		

Minor Lane/Major Mvmt	NBT	NBRWBLn1	SBL	SBT
Capacity (veh/h)	-	-	359	287
HCM Lane V/C Ratio	-	-	0.106	0.045
HCM Control Delay (s)	-	-	16.2	18.1
HCM Lane LOS	-	-	C	C
HCM 95th %tile Q(veh)	-	-	0.4	0.1

Intersection						
Int Delay, s/veh	0.3					
Movement	WBL	WBR	NBT	NBR	SBL	SBT
Lane Configurations		↑ ↑ ↑	↑ ↑ ↑			↑ ↑ ↑
Traffic Vol, veh/h	0	57	1309	3	0	1532
Future Vol, veh/h	0	57	1309	3	0	1532
Conflicting Peds, #/hr	0	0	0	0	0	0
Sign Control	Stop	Stop	Free	Free	Free	Free
RT Channelized	-	None	-	None	-	None
Storage Length	-	0	-	-	-	-
Veh in Median Storage, #	0	-	0	-	-	0
Grade, %	0	-	0	-	-	0
Peak Hour Factor	100	100	100	100	100	100
Heavy Vehicles, %	2	2	2	2	2	2
Mvmt Flow	0	57	1309	3	0	1532

Major/Minor	Minor1	Major1	Major2		
Conflicting Flow All	-	656	0	0	-
Stage 1	-	-	-	-	-
Stage 2	-	-	-	-	-
Critical Hdwy	-	7.14	-	-	-
Critical Hdwy Stg 1	-	-	-	-	-
Critical Hdwy Stg 2	-	-	-	-	-
Follow-up Hdwy	-	3.92	-	-	-
Pot Cap-1 Maneuver	0	350	-	-	0
Stage 1	0	-	-	-	0
Stage 2	0	-	-	-	0
Platoon blocked, %			-	-	-
Mov Cap-1 Maneuver	-	350	-	-	-
Mov Cap-2 Maneuver	-	-	-	-	-
Stage 1	-	-	-	-	-
Stage 2	-	-	-	-	-

Approach	WB	NB	SB
HCM Control Delay, s	17.3	0	0
HCM LOS	C		

Minor Lane/Major Mvmt	NBT	NBRWBLn1	SBT
Capacity (veh/h)	-	-	350
HCM Lane V/C Ratio	-	-	0.163
HCM Control Delay (s)	-	-	17.3
HCM Lane LOS	-	-	C
HCM 95th %tile Q(veh)	-	-	0.6

J-4

RETAIL PLAZA (70,000 SQFT)

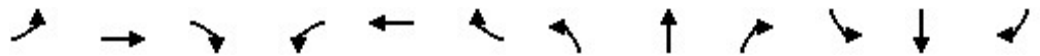

Lane Group	EBL	EBT	EBR	WBL	WBT	WBR	NBL	NBT	NBR	SBL	SBT	SBR
Lane Configurations	↖↖	↗↗	↘	↖↖	↗↗	↘	↖	↗↗	↘	↖↖	↗↗	↘
Traffic Volume (vph)	87	842	9	561	1106	450	84	745	949	284	438	210
Future Volume (vph)	87	842	9	561	1106	450	84	745	949	284	438	210
Ideal Flow (vphpl)	1800	1800	1800	1800	1800	1800	1800	1800	1800	1800	1800	1800
Lane Width (m)	3.7	3.5	4.8	3.7	3.5	3.7	3.7	3.5	4.8	3.7	3.5	3.5
Storage Length (m)	125.0		150.0	150.0		100.0	50.0		0.0	125.0		200.0
Storage Lanes	2		1	2		1	1		1	2		1
Taper Length (m)	7.6			7.6			7.6			7.6		
Lane Util. Factor	0.97	0.95	1.00	0.97	0.95	1.00	1.00	0.95	1.00	0.97	0.95	1.00
Ped Bike Factor	1.00		0.98	1.00		0.98	1.00		0.98	1.00		0.98
Fr _t			0.850			0.850			0.850			0.850
Fl _t Protected	0.950			0.950			0.950			0.950		
Satd. Flow (prot)	3022	3161	1535	3225	3252	1488	1662	3349	1683	3195	3221	1427
Fl _t Permitted	0.950			0.950			0.950			0.950		
Satd. Flow (perm)	3020	3161	1511	3222	3252	1465	1659	3349	1658	3188	3221	1405
Right Turn on Red			Yes			Yes			Yes			Yes
Satd. Flow (RTOR)			182			272			248			200
Link Speed (k/h)		80			80			60				60
Link Distance (m)		187.8			279.7			97.7				205.8
Travel Time (s)		8.5			12.6			5.9				12.3
Confl. Peds. (#/hr)	2		2	2		2	2		2	2		2
Peak Hour Factor	1.00	1.00	1.00	1.00	1.00	1.00	1.00	1.00	1.00	1.00	1.00	1.00
Heavy Vehicles (%)	11%	7%	13%	4%	4%	4%	4%	1%	3%	5%	5%	6%
Adj. Flow (vph)	87	842	9	561	1106	450	84	745	949	284	438	210
Shared Lane Traffic (%)												
Lane Group Flow (vph)	87	842	9	561	1106	450	84	745	949	284	438	210
Turn Type	Prot	NA	Perm	Prot	NA	Perm	Prot	NA	Perm	Prot	NA	Perm
Protected Phases	5	2		1	6		7	4		3	8	
Permitted Phases			2			6			4			8
Detector Phase	5	2	2	1	6	6	7	4	4	3	8	8
Switch Phase												
Minimum Initial (s)	1.0	1.0	1.0	1.0	1.0	1.0	1.0	1.0	1.0	1.0	1.0	1.0
Minimum Split (s)	11.6	31.8	31.8	11.6	34.2	34.2	11.6	31.6	31.6	11.6	31.6	31.6
Total Split (s)	16.0	48.0	48.0	28.0	60.0	60.0	20.0	44.0	44.0	20.0	44.0	44.0
Total Split (%)	11.4%	34.3%	34.3%	20.0%	42.9%	42.9%	14.3%	31.4%	31.4%	14.3%	31.4%	31.4%
Maximum Green (s)	9.4	41.2	41.2	21.4	53.2	53.2	13.4	37.4	37.4	13.4	37.4	37.4
Yellow Time (s)	3.7	4.6	4.6	3.7	4.6	4.6	3.7	3.7	3.7	3.7	3.7	3.7
All-Red Time (s)	2.9	2.2	2.2	2.9	2.2	2.2	2.9	2.9	2.9	2.9	2.9	2.9
Lost Time Adjust (s)	0.0	0.0	0.0	0.0	0.0	0.0	0.0	0.0	0.0	0.0	0.0	0.0
Total Lost Time (s)	6.6	6.8	6.8	6.6	6.8	6.8	6.6	6.6	6.6	6.6	6.6	6.6
Lead/Lag	Lead	Lag	Lag	Lead	Lag	Lag	Lead	Lag	Lag	Lead	Lag	Lag
Lead-Lag Optimize?	Yes	Yes	Yes	Yes	Yes	Yes	Yes	Yes	Yes	Yes	Yes	Yes
Vehicle Extension (s)	3.0	3.0	3.0	3.0	3.0	3.0	3.0	3.0	3.0	3.0	3.0	3.0
Recall Mode	None	C-Max	C-Max	None	C-Max	C-Max	None	Max	Max	None	Max	Max
Walk Time (s)		7.0	7.0		7.0	7.0		7.0	7.0		7.0	7.0
Flash Dont Walk (s)		18.0	18.0		18.0	18.0		17.0	17.0		17.0	17.0
Pedestrian Calls (#/hr)		2	2		2	2		2	2		2	2
Act Effct Green (s)	8.6	41.2	41.2	21.4	54.0	54.0	11.4	37.4	37.4	13.4	39.4	39.4
Actuated g/C Ratio	0.06	0.29	0.29	0.15	0.39	0.39	0.08	0.27	0.27	0.10	0.28	0.28

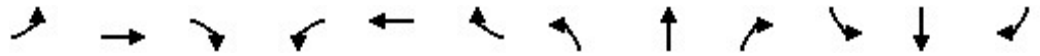

Lane Group	EBL	EBT	EBR	WBL	WBT	WBR	NBL	NBT	NBR	SBL	SBT	SBR
v/c Ratio	0.47	0.91	0.02	1.14	0.88	0.61	0.62	0.83	1.52	0.93	0.48	0.39
Control Delay	71.7	61.7	0.0	137.0	49.8	17.0	81.7	57.7	269.4	98.9	44.4	8.4
Queue Delay	0.0	0.0	0.0	0.0	0.0	0.0	0.0	0.0	0.0	0.0	0.0	0.0
Total Delay	71.7	61.7	0.0	137.0	49.8	17.0	81.7	57.7	269.4	98.9	44.4	8.4
LOS	E	E	A	F	D	B	F	E	F	F	D	A
Approach Delay		62.0			65.9			171.8			52.9	
Approach LOS		E			E			F			D	
Queue Length 50th (m)	11.1	109.0	0.0	~85.7	138.6	35.9	20.9	94.7	~289.9	37.6	49.5	1.9
Queue Length 95th (m)	19.5	#142.2	0.0	#119.0	#169.0	69.5	37.0	117.3	#362.9	#62.7	65.8	20.4
Internal Link Dist (m)		163.8			255.7			73.7			181.8	
Turn Bay Length (m)	125.0		150.0	150.0		100.0	50.0			125.0		200.0
Base Capacity (vph)	202	930	573	492	1253	732	159	894	624	305	906	538
Starvation Cap Reductn	0	0	0	0	0	0	0	0	0	0	0	0
Spillback Cap Reductn	0	0	0	0	0	0	0	0	0	0	0	0
Storage Cap Reductn	0	0	0	0	0	0	0	0	0	0	0	0
Reduced v/c Ratio	0.43	0.91	0.02	1.14	0.88	0.61	0.53	0.83	1.52	0.93	0.48	0.39

Intersection Summary

Area Type: Other
 Cycle Length: 140
 Actuated Cycle Length: 140
 Offset: 68 (49%), Referenced to phase 2:EBT and 6:WBT, Start of Green
 Natural Cycle: 150
 Control Type: Actuated-Coordinated
 Maximum v/c Ratio: 1.52
 Intersection Signal Delay: 95.8 Intersection LOS: F
 Intersection Capacity Utilization 112.0% ICU Level of Service H
 Analysis Period (min) 15
 ~ Volume exceeds capacity, queue is theoretically infinite.
 Queue shown is maximum after two cycles.
 # 95th percentile volume exceeds capacity, queue may be longer.
 Queue shown is maximum after two cycles.

Splits and Phases: 3: Prince of Wales Drive & West Hunt Club Road/Hunt Club Road

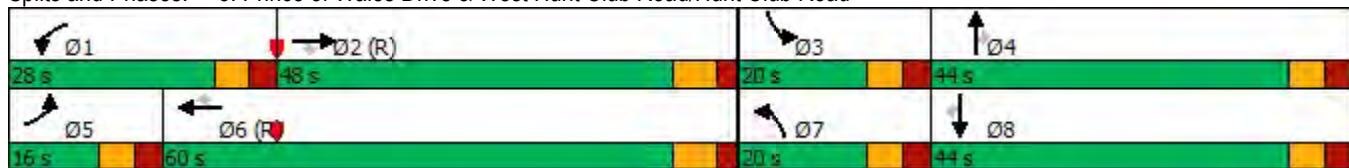

Lanes, Volumes, Timings
7: Prince of Wales Drive & Deakin Street

2175 Prince of Wales - 2025 AM - retail 70000 sqft

02/29/2024



Lane Group	EBL	EBR	NBL	NBT	SBT	SBR
Lane Configurations						
Traffic Volume (vph)	514	22	158	1256	569	407
Future Volume (vph)	514	22	158	1256	569	407
Ideal Flow (vphpl)	1800	1800	1800	1800	1800	1800
Storage Length (m)	70.0	0.0	100.0			0.0
Storage Lanes	1	0	1			0
Taper Length (m)	7.6		7.6			
Lane Util. Factor	0.97	0.95	1.00	0.95	0.95	0.95
Ped Bike Factor	1.00		1.00		0.99	
Frt	0.994				0.937	
Flt Protected	0.954		0.950			
Satd. Flow (prot)	3279	0	1695	3390	3144	0
Flt Permitted	0.954		0.261			
Satd. Flow (perm)	3272	0	465	3390	3144	0
Right Turn on Red		Yes				Yes
Satd. Flow (RTOR)	4				324	
Link Speed (k/h)	50			60	60	
Link Distance (m)	195.1			117.9	111.9	
Travel Time (s)	14.0			7.1	6.7	
Confl. Peds. (#/hr)	2	2	2			2
Peak Hour Factor	1.00	1.00	1.00	1.00	1.00	1.00
Adj. Flow (vph)	514	22	158	1256	569	407
Shared Lane Traffic (%)						
Lane Group Flow (vph)	536	0	158	1256	976	0
Turn Type	Prot		Perm	NA	NA	
Protected Phases	4			2	6	
Permitted Phases			2			
Detector Phase	4		2	2	6	
Switch Phase						
Minimum Initial (s)	1.0		5.0	5.0	5.0	
Minimum Split (s)	33.6		29.4	29.4	29.4	
Total Split (s)	33.6		67.0	67.0	67.0	
Total Split (%)	33.4%		66.6%	66.6%	66.6%	
Maximum Green (s)	27.0		60.6	60.6	60.6	
Yellow Time (s)	3.3		3.7	3.7	3.7	
All-Red Time (s)	3.3		2.7	2.7	2.7	
Lost Time Adjust (s)	0.0		0.0	0.0	0.0	
Total Lost Time (s)	6.6		6.4	6.4	6.4	
Lead/Lag						
Lead-Lag Optimize?						
Vehicle Extension (s)	3.0		3.0	3.0	3.0	
Recall Mode	None		C-Max	C-Max	C-Max	
Walk Time (s)	7.0		7.0	7.0	7.0	
Flash Dont Walk (s)	20.0		16.0	16.0	16.0	
Pedestrian Calls (#/hr)	2		2	2	2	
Act Effct Green (s)	21.5		66.1	66.1	66.1	
Actuated g/C Ratio	0.21		0.66	0.66	0.66	
v/c Ratio	0.76		0.52	0.56	0.45	
Control Delay	44.0		17.9	11.2	6.4	



Lane Group	EBL	EBR	NBL	NBT	SBT	SBR
Queue Delay	0.0		0.0	0.0	0.0	
Total Delay	44.0		17.9	11.2	6.4	
LOS	D		B	B	A	
Approach Delay	44.0			12.0	6.4	
Approach LOS	D			B	A	
Queue Length 50th (m)	46.5		13.3	58.3	24.6	
Queue Length 95th (m)	58.6		37.1	87.7	42.7	
Internal Link Dist (m)	171.1			93.9	87.9	
Turn Bay Length (m)	70.0		100.0			
Base Capacity (vph)	882		305	2226	2175	
Starvation Cap Reductn	0		0	0	0	
Spillback Cap Reductn	0		0	0	0	
Storage Cap Reductn	0		0	0	0	
Reduced v/c Ratio	0.61		0.52	0.56	0.45	

Intersection Summary

Area Type:	Other
Cycle Length:	100.6
Actuated Cycle Length:	100.6
Offset:	0 (0%), Referenced to phase 2:NBTL and 6:SBT, Start of Green
Natural Cycle:	80
Control Type:	Actuated-Coordinated
Maximum v/c Ratio:	0.76
Intersection Signal Delay:	16.0
Intersection LOS:	B
Intersection Capacity Utilization	72.5%
ICU Level of Service	C
Analysis Period (min)	15

Splits and Phases: 7: Prince of Wales Drive & Deakin Street

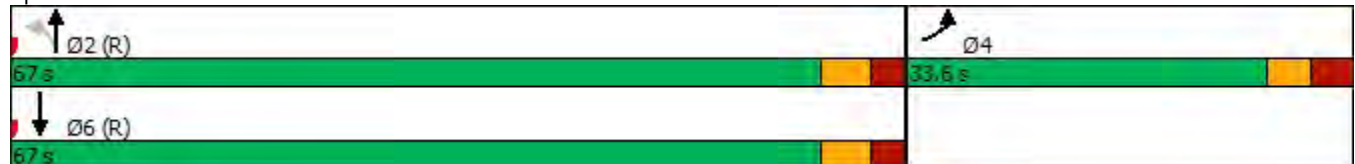

Intersection						
Int Delay, s/veh	0.6					
Movement	EBL	EBR	NBL	NBT	SBT	SBR
Lane Configurations		↗	↘	↑↑↑	↑↑↑	
Traffic Vol, veh/h	0	90	15	1777	936	84
Future Vol, veh/h	0	90	15	1777	936	84
Conflicting Peds, #/hr	20	20	20	0	0	20
Sign Control	Stop	Stop	Free	Free	Free	Free
RT Channelized	-	None	-	None	-	None
Storage Length	-	0	50	-	-	-
Veh in Median Storage, #	0	-	-	0	0	-
Grade, %	0	-	-	0	0	-
Peak Hour Factor	100	100	100	100	100	100
Heavy Vehicles, %	2	2	2	2	2	2
Mvmt Flow	0	90	15	1777	936	84

Major/Minor	Minor2	Major1	Major2		
Conflicting Flow All	-	550	1040	0	-
Stage 1	-	-	-	-	-
Stage 2	-	-	-	-	-
Critical Hdwy	-	7.14	5.34	-	-
Critical Hdwy Stg 1	-	-	-	-	-
Critical Hdwy Stg 2	-	-	-	-	-
Follow-up Hdwy	-	3.92	3.12	-	-
Pot Cap-1 Maneuver	0	410	374	-	-
Stage 1	0	-	-	-	-
Stage 2	0	-	-	-	-
Platoon blocked, %				-	-
Mov Cap-1 Maneuver	-	391	364	-	-
Mov Cap-2 Maneuver	-	-	-	-	-
Stage 1	-	-	-	-	-
Stage 2	-	-	-	-	-

Approach	EB	NB	SB
HCM Control Delay, s	16.9	0.1	0
HCM LOS	C		

Minor Lane/Major Mvmt	NBL	NBT	EBLn1	SBT	SBR
Capacity (veh/h)	364	-	391	-	-
HCM Lane V/C Ratio	0.041	-	0.23	-	-
HCM Control Delay (s)	15.3	-	16.9	-	-
HCM Lane LOS	C	-	C	-	-
HCM 95th %tile Q(veh)	0.1	-	0.9	-	-

Intersection						
Int Delay, s/veh	0.8					
Movement	WBL	WBR	NBT	NBR	SBL	SBT
Lane Configurations		↑ ↑ ↑	↑ ↑ ↑		↑	↑ ↑
Traffic Vol, veh/h	0	18	1756	15	50	977
Future Vol, veh/h	0	18	1756	15	50	977
Conflicting Peds, #/hr	0	0	0	0	0	0
Sign Control	Stop	Stop	Free	Free	Free	Free
RT Channelized	-	None	-	None	-	None
Storage Length	-	0	-	-	0	-
Veh in Median Storage, #	0	-	0	-	-	0
Grade, %	0	-	0	-	-	0
Peak Hour Factor	100	100	100	100	100	100
Heavy Vehicles, %	2	2	2	2	2	2
Mvmt Flow	0	18	1756	15	50	977

Major/Minor	Minor1	Major1	Major2
Conflicting Flow All	-	886	0 0 1771 0
Stage 1	-	-	- - - -
Stage 2	-	-	- - - -
Critical Hdwy	-	7.14	- - 5.34 -
Critical Hdwy Stg 1	-	-	- - - -
Critical Hdwy Stg 2	-	-	- - - -
Follow-up Hdwy	-	3.92	- - 3.12 -
Pot Cap-1 Maneuver	0	247	- - 163 -
Stage 1	0	-	- - - -
Stage 2	0	-	- - - -
Platoon blocked, %			- - - -
Mov Cap-1 Maneuver	-	247	- - 163 -
Mov Cap-2 Maneuver	-	-	- - - -
Stage 1	-	-	- - - -
Stage 2	-	-	- - - -

Approach	WB	NB	SB
HCM Control Delay, s	20.7	0	1.8
HCM LOS	C		

Minor Lane/Major Mvmt	NBT	NBRWBLn1	SBL	SBT
Capacity (veh/h)	-	- 247	163	-
HCM Lane V/C Ratio	-	- 0.073	0.307	-
HCM Control Delay (s)	-	- 20.7	36.6	-
HCM Lane LOS	-	- C	E	-
HCM 95th %tile Q(veh)	-	- 0.2	1.2	-

Intersection						
Int Delay, s/veh	0.2					
Movement	WBL	WBR	NBT	NBR	SBL	SBT
Lane Configurations		↑ ↑ ↑	↑ ↑ ↑			↑ ↑ ↑
Traffic Vol, veh/h	0	28	1764	10	0	1027
Future Vol, veh/h	0	28	1764	10	0	1027
Conflicting Peds, #/hr	0	0	0	0	0	0
Sign Control	Stop	Stop	Free	Free	Free	Free
RT Channelized	-	None	-	None	-	None
Storage Length	-	0	-	-	-	-
Veh in Median Storage, #	0	-	0	-	-	0
Grade, %	0	-	0	-	-	0
Peak Hour Factor	100	100	100	100	100	100
Heavy Vehicles, %	2	2	2	2	2	2
Mvmt Flow	0	28	1764	10	0	1027

Major/Minor	Minor1	Major1	Major2		
Conflicting Flow All	-	887	0	0	-
Stage 1	-	-	-	-	-
Stage 2	-	-	-	-	-
Critical Hdwy	-	7.14	-	-	-
Critical Hdwy Stg 1	-	-	-	-	-
Critical Hdwy Stg 2	-	-	-	-	-
Follow-up Hdwy	-	3.92	-	-	-
Pot Cap-1 Maneuver	0	247	-	-	0
Stage 1	0	-	-	-	0
Stage 2	0	-	-	-	0
Platoon blocked, %			-	-	-
Mov Cap-1 Maneuver	-	247	-	-	-
Mov Cap-2 Maneuver	-	-	-	-	-
Stage 1	-	-	-	-	-
Stage 2	-	-	-	-	-

Approach	WB	NB	SB
HCM Control Delay, s	21.4	0	0
HCM LOS	C		

Minor Lane/Major Mvmt	NBT	NBRWBLn1	SBT
Capacity (veh/h)	-	-	247
HCM Lane V/C Ratio	-	-	0.113
HCM Control Delay (s)	-	-	21.4
HCM Lane LOS	-	-	C
HCM 95th %tile Q(veh)	-	-	0.4

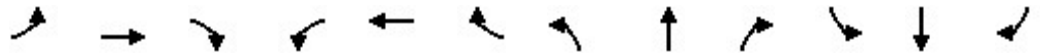

Lane Group	EBL	EBT	EBR	WBL	WBT	WBR	NBL	NBT	NBR	SBL	SBT	SBR
Lane Configurations	↖↗	↕	↖	↖↗	↕	↖	↖	↕	↖	↖↗	↕	↖
Traffic Volume (vph)	103	1082	62	665	1242	344	94	500	825	451	872	117
Future Volume (vph)	103	1082	62	665	1242	344	94	500	825	451	872	117
Ideal Flow (vphpl)	1800	1800	1800	1800	1800	1800	1800	1800	1800	1800	1800	1800
Lane Width (m)	3.7	3.5	4.8	3.7	3.5	3.7	3.7	3.5	4.8	3.7	3.5	3.5
Storage Length (m)	125.0		150.0	150.0		100.0	50.0		0.0	125.0		200.0
Storage Lanes	2		1	2		1	1		1	2		1
Taper Length (m)	7.6			7.6			7.6			7.6		
Lane Util. Factor	0.97	0.95	1.00	0.97	0.95	1.00	1.00	0.95	1.00	0.97	0.95	1.00
Ped Bike Factor	1.00		0.98	1.00		0.98	1.00		0.98	1.00		0.98
Fr _t			0.850			0.850			0.850			0.850
Fl _t Protected	0.950			0.950			0.950			0.950		
Satd. Flow (prot)	3288	3283	1651	3321	3252	1488	1729	3316	1717	3195	3349	1455
Fl _t Permitted	0.950			0.950			0.950			0.950		
Satd. Flow (perm)	3286	3283	1626	3318	3252	1464	1727	3316	1690	3185	3349	1432
Right Turn on Red			Yes			Yes			Yes			Yes
Satd. Flow (RTOR)			218			344			218			170
Link Speed (k/h)		80			80			60				60
Link Distance (m)		187.8			279.7			97.7				205.8
Travel Time (s)		8.5			12.6			5.9				12.3
Confl. Peds. (#/hr)	2		2	2		2	2		2	2		2
Peak Hour Factor	1.00	1.00	1.00	1.00	1.00	1.00	1.00	1.00	1.00	1.00	1.00	1.00
Heavy Vehicles (%)	2%	3%	5%	1%	4%	4%	0%	2%	1%	5%	1%	4%
Adj. Flow (vph)	103	1082	62	665	1242	344	94	500	825	451	872	117
Shared Lane Traffic (%)												
Lane Group Flow (vph)	103	1082	62	665	1242	344	94	500	825	451	872	117
Turn Type	Prot	NA	Perm	Prot	NA	Perm	Prot	NA	Perm	Prot	NA	Perm
Protected Phases	5	2		1	6		7	4		3	8	
Permitted Phases			2			6			4			8
Detector Phase	5	2	2	1	6	6	7	4	4	3	8	8
Switch Phase												
Minimum Initial (s)	5.0	5.0	5.0	5.0	5.0	5.0	5.0	5.0	5.0	5.0	5.0	5.0
Minimum Split (s)	11.6	30.6	30.6	11.6	31.6	31.6	11.6	30.6	30.6	11.6	31.6	31.6
Total Split (s)	15.0	63.0	63.0	28.0	76.0	76.0	13.0	31.0	31.0	28.0	46.0	46.0
Total Split (%)	10.0%	42.0%	42.0%	18.7%	50.7%	50.7%	8.7%	20.7%	20.7%	18.7%	30.7%	30.7%
Maximum Green (s)	8.4	56.4	56.4	21.4	69.4	69.4	6.4	24.4	24.4	21.4	39.4	39.4
Yellow Time (s)	3.7	3.7	3.7	3.7	3.7	3.7	3.7	3.7	3.7	3.7	3.7	3.7
All-Red Time (s)	2.9	2.9	2.9	2.9	2.9	2.9	2.9	2.9	2.9	2.9	2.9	2.9
Lost Time Adjust (s)	0.0	0.0	0.0	0.0	0.0	0.0	0.0	0.0	0.0	0.0	0.0	0.0
Total Lost Time (s)	6.6	6.6	6.6	6.6	6.6	6.6	6.6	6.6	6.6	6.6	6.6	6.6
Lead/Lag	Lead	Lag	Lag	Lead	Lag	Lag	Lead	Lag	Lag	Lead	Lag	Lag
Lead-Lag Optimize?	Yes	Yes	Yes	Yes	Yes	Yes	Yes	Yes	Yes	Yes	Yes	Yes
Vehicle Extension (s)	3.0	3.0	3.0	3.0	3.0	3.0	3.0	3.0	3.0	3.0	3.0	3.0
Recall Mode	None	C-Max	C-Max	None	C-Max	C-Max	None	Max	Max	None	Max	Max
Walk Time (s)		7.0	7.0		7.0	7.0		7.0	7.0		7.0	7.0
Flash Dont Walk (s)		17.0	17.0		18.0	18.0		17.0	17.0		18.0	18.0
Pedestrian Calls (#/hr)		2	2		2	2		2	2		2	2
Act Effct Green (s)	8.2	56.4	56.4	21.4	69.6	69.6	6.4	24.4	24.4	21.4	39.4	39.4
Actuated g/C Ratio	0.05	0.38	0.38	0.14	0.46	0.46	0.04	0.16	0.16	0.14	0.26	0.26



Lane Group	EBL	EBT	EBR	WBL	WBT	WBR	NBL	NBT	NBR	SBL	SBT	SBR
v/c Ratio	0.58	0.88	0.08	1.41	0.82	0.40	1.29	0.93	1.81	0.99	0.99	0.23
Control Delay	82.3	52.9	0.2	239.8	40.6	3.6	253.4	86.0	395.9	103.3	83.0	2.1
Queue Delay	0.0	0.0	0.0	0.0	0.0	0.0	0.0	0.0	0.0	0.0	0.0	0.0
Total Delay	82.3	52.9	0.2	239.8	40.6	3.6	253.4	86.0	395.9	103.3	83.0	2.1
LOS	F	D	A	F	D	A	F	F	F	F	F	A
Approach Delay		52.7			93.8			277.3			82.8	
Approach LOS		D			F			F			F	
Queue Length 50th (m)	14.4	144.7	0.0	~125.3	153.4	0.0	~32.4	72.0	~288.3	64.5	126.2	0.0
Queue Length 95th (m)	23.9	172.2	0.0	#160.7	181.3	15.6	#67.1	#102.3	#360.2	#97.2	#167.1	2.9
Internal Link Dist (m)		163.8			255.7			73.7			181.8	
Turn Bay Length (m)	125.0		150.0	150.0		100.0	50.0			125.0		200.0
Base Capacity (vph)	184	1234	747	473	1509	864	73	539	457	455	879	501
Starvation Cap Reductn	0	0	0	0	0	0	0	0	0	0	0	0
Spillback Cap Reductn	0	0	0	0	0	0	0	0	0	0	0	0
Storage Cap Reductn	0	0	0	0	0	0	0	0	0	0	0	0
Reduced v/c Ratio	0.56	0.88	0.08	1.41	0.82	0.40	1.29	0.93	1.81	0.99	0.99	0.23

Intersection Summary

Area Type: Other
 Cycle Length: 150
 Actuated Cycle Length: 150
 Offset: 31 (21%), Referenced to phase 2:EBT and 6:WBT, Start of Green
 Natural Cycle: 150
 Control Type: Actuated-Coordinated
 Maximum v/c Ratio: 1.81
 Intersection Signal Delay: 124.2
 Intersection Capacity Utilization 115.8%
 Analysis Period (min) 15
 Intersection LOS: F
 ICU Level of Service H

~ Volume exceeds capacity, queue is theoretically infinite.
 Queue shown is maximum after two cycles.

95th percentile volume exceeds capacity, queue may be longer.
 Queue shown is maximum after two cycles.

Splits and Phases: 3: Prince of Wales Drive & West Hunt Club Road/Hunt Club Road

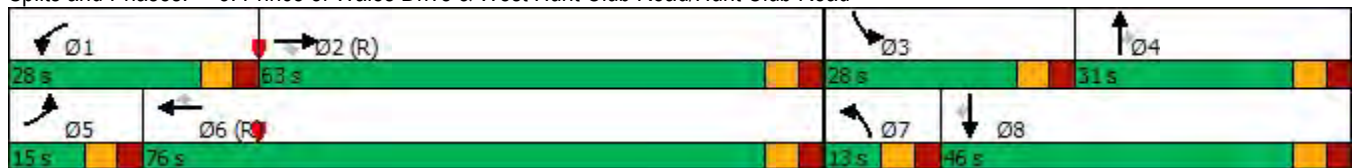

Lanes, Volumes, Timings
7: Prince of Wales Drive & Deakin Street

2175 Prince of Wales - 2025 PM - retail 70000 sqft
03/01/2024



Lane Group	EBL	EBR	NBL	NBT	SBT	SBR
Lane Configurations						
Traffic Volume (vph)	487	187	34	812	1388	179
Future Volume (vph)	487	187	34	812	1388	179
Ideal Flow (vphpl)	1800	1800	1800	1800	1800	1800
Storage Length (m)	70.0	0.0	100.0			0.0
Storage Lanes	1	0	1			0
Taper Length (m)	7.6		7.6			
Lane Util. Factor	0.97	0.95	1.00	0.95	0.95	0.95
Ped Bike Factor	0.95				0.99	
Frt	0.958				0.983	
Flt Protected	0.965		0.950			
Satd. Flow (prot)	3124	0	1729	3390	3318	0
Flt Permitted	0.965		0.109			
Satd. Flow (perm)	3034	0	198	3390	3318	0
Right Turn on Red		Yes				Yes
Satd. Flow (RTOR)	45				25	
Link Speed (k/h)	50			60	60	
Link Distance (m)	195.1			117.9	111.9	
Travel Time (s)	14.0			7.1	6.7	
Confl. Peds. (#/hr)	20	20	20			20
Peak Hour Factor	1.00	1.00	1.00	1.00	1.00	1.00
Heavy Vehicles (%)	2%	2%	0%	2%	1%	5%
Adj. Flow (vph)	487	187	34	812	1388	179
Shared Lane Traffic (%)						
Lane Group Flow (vph)	674	0	34	812	1567	0
Turn Type	Prot		Perm	NA	NA	
Protected Phases	4			2	6	
Permitted Phases			2			
Detector Phase	4		2	2	6	
Switch Phase						
Minimum Initial (s)	5.0		5.0	5.0	5.0	
Minimum Split (s)	24.6		24.4	24.4	24.4	
Total Split (s)	33.0		87.0	87.0	87.0	
Total Split (%)	27.5%		72.5%	72.5%	72.5%	
Maximum Green (s)	26.4		80.6	80.6	80.6	
Yellow Time (s)	3.3		3.7	3.7	3.7	
All-Red Time (s)	3.3		2.7	2.7	2.7	
Lost Time Adjust (s)	0.0		0.0	0.0	0.0	
Total Lost Time (s)	6.6		6.4	6.4	6.4	
Lead/Lag						
Lead-Lag Optimize?						
Vehicle Extension (s)	3.0		3.0	3.0	3.0	
Recall Mode	None		C-Max	C-Max	C-Max	
Walk Time (s)	7.0		7.0	7.0	7.0	
Flash Dont Walk (s)	11.0		11.0	11.0	11.0	
Pedestrian Calls (#/hr)	0		0	0	0	
Act Effct Green (s)	26.1		80.9	80.9	80.9	
Actuated g/C Ratio	0.22		0.67	0.67	0.67	
v/c Ratio	0.95		0.26	0.36	0.70	



Lane Group	EBL	EBR	NBL	NBT	SBT	SBR
Control Delay	66.0		13.7	8.9	13.9	
Queue Delay	0.0		0.0	0.0	0.0	
Total Delay	66.0		13.7	8.9	13.9	
LOS	E		B	A	B	
Approach Delay	66.0			9.1	13.9	
Approach LOS	E			A	B	
Queue Length 50th (m)	70.1		2.7	36.5	99.6	
Queue Length 95th (m)	#102.2		8.4	45.9	122.1	
Internal Link Dist (m)	171.1			93.9	87.9	
Turn Bay Length (m)	70.0		100.0			
Base Capacity (vph)	722		133	2286	2245	
Starvation Cap Reductn	0		0	0	0	
Spillback Cap Reductn	0		0	0	0	
Storage Cap Reductn	0		0	0	0	
Reduced v/c Ratio	0.93		0.26	0.36	0.70	

Intersection Summary

Area Type: Other
 Cycle Length: 120
 Actuated Cycle Length: 120
 Offset: 0 (0%), Referenced to phase 2:NBT and 6:SBT, Start of Green
 Natural Cycle: 65
 Control Type: Actuated-Coordinated
 Maximum v/c Ratio: 0.95
 Intersection Signal Delay: 24.0
 Intersection LOS: C
 Intersection Capacity Utilization 79.0%
 ICU Level of Service D
 Analysis Period (min) 15
 # 95th percentile volume exceeds capacity, queue may be longer.
 Queue shown is maximum after two cycles.

Splits and Phases: 7: Prince of Wales Drive & Deakin Street

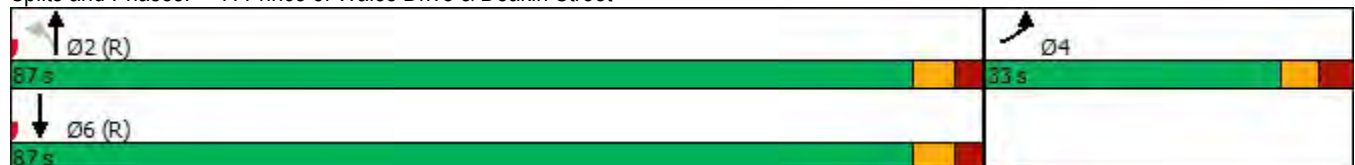

Intersection						
Int Delay, s/veh	0.3					
Movement	EBL	EBR	NBL	NBT	SBT	SBR
Lane Configurations		↗	↘	↑↑↑	↑↑↑	
Traffic Vol, veh/h	0	36	6	1419	1627	32
Future Vol, veh/h	0	36	6	1419	1627	32
Conflicting Peds, #/hr	20	20	20	0	0	20
Sign Control	Stop	Stop	Free	Free	Free	Free
RT Channelized	-	None	-	None	-	None
Storage Length	-	0	50	-	-	-
Veh in Median Storage, #	0	-	-	0	0	-
Grade, %	0	-	-	0	0	-
Peak Hour Factor	100	100	100	100	100	100
Heavy Vehicles, %	2	2	2	2	2	2
Mvmt Flow	0	36	6	1419	1627	32

Major/Minor	Minor2	Major1	Major2			
Conflicting Flow All	-	870	1679	0	-	0
Stage 1	-	-	-	-	-	-
Stage 2	-	-	-	-	-	-
Critical Hdwy	-	7.14	5.34	-	-	-
Critical Hdwy Stg 1	-	-	-	-	-	-
Critical Hdwy Stg 2	-	-	-	-	-	-
Follow-up Hdwy	-	3.92	3.12	-	-	-
Pot Cap-1 Maneuver	0	253	181	-	-	-
Stage 1	0	-	-	-	-	-
Stage 2	0	-	-	-	-	-
Platoon blocked, %				-	-	-
Mov Cap-1 Maneuver	-	242	176	-	-	-
Mov Cap-2 Maneuver	-	-	-	-	-	-
Stage 1	-	-	-	-	-	-
Stage 2	-	-	-	-	-	-

Approach	EB	NB	SB
HCM Control Delay, s	22.5	0.1	0
HCM LOS	C		

Minor Lane/Major Mvmt	NBL	NBT	EBLn1	SBT	SBR
Capacity (veh/h)	176	-	242	-	-
HCM Lane V/C Ratio	0.034	-	0.149	-	-
HCM Control Delay (s)	26.2	-	22.5	-	-
HCM Lane LOS	D	-	C	-	-
HCM 95th %tile Q(veh)	0.1	-	0.5	-	-

Intersection						
Int Delay, s/veh	1.5					
Movement	WBL	WBR	NBT	NBR	SBL	SBT
Lane Configurations		↗ ↑↑↑	↗ ↑↑↑		↘ ↑↑	↘ ↑↑
Traffic Vol, veh/h	0	74	1264	36	119	1545
Future Vol, veh/h	0	74	1264	36	119	1545
Conflicting Peds, #/hr	0	0	0	0	0	0
Sign Control	Stop	Stop	Free	Free	Free	Free
RT Channelized	-	None	-	None	-	None
Storage Length	-	0	-	-	0	-
Veh in Median Storage, #	0	-	0	-	-	0
Grade, %	0	-	0	-	-	0
Peak Hour Factor	100	100	100	100	100	100
Heavy Vehicles, %	2	2	2	2	2	2
Mvmt Flow	0	74	1264	36	119	1545

Major/Minor	Minor1	Major1	Major2		
Conflicting Flow All	-	650	0	0	1300
Stage 1	-	-	-	-	-
Stage 2	-	-	-	-	-
Critical Hdwy	-	7.14	-	-	5.34
Critical Hdwy Stg 1	-	-	-	-	-
Critical Hdwy Stg 2	-	-	-	-	-
Follow-up Hdwy	-	3.92	-	-	3.12
Pot Cap-1 Maneuver	0	353	-	-	280
Stage 1	0	-	-	-	-
Stage 2	0	-	-	-	-
Platoon blocked, %					
Mov Cap-1 Maneuver	-	353	-	-	280
Mov Cap-2 Maneuver	-	-	-	-	-
Stage 1	-	-	-	-	-
Stage 2	-	-	-	-	-

Approach	WB	NB	SB
HCM Control Delay, s	17.9	0	1.9
HCM LOS	C		

Minor Lane/Major Mvmt	NBT	NBRWBLn1	SBL	SBT
Capacity (veh/h)	-	-	353	280
HCM Lane V/C Ratio	-	-	0.21	0.425
HCM Control Delay (s)	-	-	17.9	27
HCM Lane LOS	-	-	C	D
HCM 95th %tile Q(veh)	-	-	0.8	2

Intersection						
Int Delay, s/veh	0.7					
Movement	WBL	WBR	NBT	NBR	SBL	SBT
Lane Configurations		↑ ↑ ↑	↑ ↑ ↑			↑ ↑ ↑
Traffic Vol, veh/h	0	111	1314	24	0	1664
Future Vol, veh/h	0	111	1314	24	0	1664
Conflicting Peds, #/hr	0	0	0	0	0	0
Sign Control	Stop	Stop	Free	Free	Free	Free
RT Channelized	-	None	-	None	-	None
Storage Length	-	0	-	-	-	-
Veh in Median Storage, #	0	-	0	-	-	0
Grade, %	0	-	0	-	-	0
Peak Hour Factor	100	100	100	100	100	100
Heavy Vehicles, %	2	2	2	2	2	2
Mvmt Flow	0	111	1314	24	0	1664

Major/Minor	Minor1	Major1	Major2
Conflicting Flow All	-	669	0
Stage 1	-	-	-
Stage 2	-	-	-
Critical Hdwy	-	7.14	-
Critical Hdwy Stg 1	-	-	-
Critical Hdwy Stg 2	-	-	-
Follow-up Hdwy	-	3.92	-
Pot Cap-1 Maneuver	0	343	-
Stage 1	0	-	-
Stage 2	0	-	-
Platoon blocked, %	-	-	-
Mov Cap-1 Maneuver	-	343	-
Mov Cap-2 Maneuver	-	-	-
Stage 1	-	-	-
Stage 2	-	-	-

Approach	WB	NB	SB
HCM Control Delay, s	20.4	0	0
HCM LOS	C		

Minor Lane/Major Mvmt	NBT	NBRWBLn1	SBT
Capacity (veh/h)	-	-	343
HCM Lane V/C Ratio	-	-	0.324
HCM Control Delay (s)	-	-	20.4
HCM Lane LOS	-	-	C
HCM 95th %tile Q(veh)	-	-	1.4

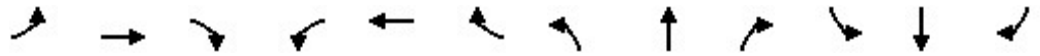

Lane Group	EBL	EBT	EBR	WBL	WBT	WBR	NBL	NBT	NBR	SBL	SBT	SBR
Lane Configurations	↖↖	↗↗	↘	↖↖	↗↗	↘	↖	↗↗	↘	↖↖	↗↗	↘
Traffic Volume (vph)	89	863	9	573	1133	462	85	763	972	291	447	215
Future Volume (vph)	89	863	9	573	1133	462	85	763	972	291	447	215
Ideal Flow (vphpl)	1800	1800	1800	1800	1800	1800	1800	1800	1800	1800	1800	1800
Lane Width (m)	3.7	3.5	4.8	3.7	3.5	3.7	3.7	3.5	4.8	3.7	3.5	3.5
Storage Length (m)	125.0		150.0	150.0		100.0	50.0		0.0	125.0		200.0
Storage Lanes	2		1	2		1	1		1	2		1
Taper Length (m)	7.6			7.6			7.6			7.6		
Lane Util. Factor	0.97	0.95	1.00	0.97	0.95	1.00	1.00	0.95	1.00	0.97	0.95	1.00
Ped Bike Factor	1.00		0.98	1.00		0.98	1.00		0.98	1.00		0.98
Fr _t			0.850			0.850			0.850			0.850
Fl _t Protected	0.950			0.950			0.950			0.950		
Satd. Flow (prot)	3022	3161	1535	3225	3252	1488	1662	3349	1683	3195	3221	1427
Fl _t Permitted	0.950			0.950			0.950			0.950		
Satd. Flow (perm)	3020	3161	1511	3222	3252	1465	1660	3349	1658	3188	3221	1405
Right Turn on Red			Yes			Yes			Yes			Yes
Satd. Flow (RTOR)			182			270			246			198
Link Speed (k/h)		80			80			60			60	
Link Distance (m)		187.8			279.7			97.7			205.8	
Travel Time (s)		8.5			12.6			5.9			12.3	
Confl. Peds. (#/hr)	2		2	2		2	2		2	2		2
Peak Hour Factor	1.00	1.00	1.00	1.00	1.00	1.00	1.00	1.00	1.00	1.00	1.00	1.00
Heavy Vehicles (%)	11%	7%	13%	4%	4%	4%	4%	1%	3%	5%	5%	6%
Adj. Flow (vph)	89	863	9	573	1133	462	85	763	972	291	447	215
Shared Lane Traffic (%)												
Lane Group Flow (vph)	89	863	9	573	1133	462	85	763	972	291	447	215
Turn Type	Prot	NA	Perm	Prot	NA	Perm	Prot	NA	Perm	Prot	NA	Perm
Protected Phases	5	2		1	6		7	4		3	8	
Permitted Phases			2			6			4			8
Detector Phase	5	2	2	1	6	6	7	4	4	3	8	8
Switch Phase												
Minimum Initial (s)	1.0	1.0	1.0	1.0	1.0	1.0	1.0	1.0	1.0	1.0	1.0	1.0
Minimum Split (s)	11.6	31.8	31.8	11.6	34.2	34.2	11.6	31.6	31.6	11.6	31.6	31.6
Total Split (s)	16.0	48.0	48.0	28.0	60.0	60.0	20.0	44.0	44.0	20.0	44.0	44.0
Total Split (%)	11.4%	34.3%	34.3%	20.0%	42.9%	42.9%	14.3%	31.4%	31.4%	14.3%	31.4%	31.4%
Maximum Green (s)	9.4	41.2	41.2	21.4	53.2	53.2	13.4	37.4	37.4	13.4	37.4	37.4
Yellow Time (s)	3.7	4.6	4.6	3.7	4.6	4.6	3.7	3.7	3.7	3.7	3.7	3.7
All-Red Time (s)	2.9	2.2	2.2	2.9	2.2	2.2	2.9	2.9	2.9	2.9	2.9	2.9
Lost Time Adjust (s)	0.0	0.0	0.0	0.0	0.0	0.0	0.0	0.0	0.0	0.0	0.0	0.0
Total Lost Time (s)	6.6	6.8	6.8	6.6	6.8	6.8	6.6	6.6	6.6	6.6	6.6	6.6
Lead/Lag	Lead	Lag	Lag	Lead	Lag	Lag	Lead	Lag	Lag	Lead	Lag	Lag
Lead-Lag Optimize?	Yes	Yes	Yes	Yes	Yes	Yes	Yes	Yes	Yes	Yes	Yes	Yes
Vehicle Extension (s)	3.0	3.0	3.0	3.0	3.0	3.0	3.0	3.0	3.0	3.0	3.0	3.0
Recall Mode	None	C-Max	C-Max	None	C-Max	C-Max	None	Max	Max	None	Max	Max
Walk Time (s)		7.0	7.0		7.0	7.0		7.0	7.0		7.0	7.0
Flash Dont Walk (s)		18.0	18.0		18.0	18.0		17.0	17.0		17.0	17.0
Pedestrian Calls (#/hr)		2	2		2	2		2	2		2	2
Act Effct Green (s)	8.7	41.2	41.2	21.4	53.9	53.9	11.4	37.4	37.4	13.4	39.4	39.4
Actuated g/C Ratio	0.06	0.29	0.29	0.15	0.38	0.38	0.08	0.27	0.27	0.10	0.28	0.28



Lane Group	EBL	EBT	EBR	WBL	WBT	WBR	NBL	NBT	NBR	SBL	SBT	SBR
v/c Ratio	0.48	0.93	0.02	1.16	0.90	0.63	0.62	0.85	1.56	0.95	0.49	0.40
Control Delay	72.0	64.6	0.0	145.2	51.9	18.1	81.9	59.2	286.4	103.4	44.7	9.2
Queue Delay	0.0	0.0	0.0	0.0	0.0	0.0	0.0	0.0	0.0	0.0	0.0	0.0
Total Delay	72.0	64.6	0.0	145.2	51.9	18.1	81.9	59.2	286.4	103.4	44.7	9.2
LOS	E	E	A	F	D	B	F	E	F	F	D	A
Approach Delay		64.7			69.4			181.6				54.6
Approach LOS		E			E			F				D
Queue Length 50th (m)	11.4	112.8	0.0	~89.0	143.8	39.6	21.2	97.7	~303.0	38.7	50.7	3.2
Queue Length 95th (m)	19.8	#148.1	0.0	#122.5	#182.4	74.4	37.5	120.6	#376.5	#64.6	67.1	22.2
Internal Link Dist (m)		163.8			255.7			73.7				181.8
Turn Bay Length (m)	125.0		150.0	150.0		100.0	50.0			125.0		200.0
Base Capacity (vph)	202	930	573	492	1252	730	159	894	623	305	905	537
Starvation Cap Reductn	0	0	0	0	0	0	0	0	0	0	0	0
Spillback Cap Reductn	0	0	0	0	0	0	0	0	0	0	0	0
Storage Cap Reductn	0	0	0	0	0	0	0	0	0	0	0	0
Reduced v/c Ratio	0.44	0.93	0.02	1.16	0.90	0.63	0.53	0.85	1.56	0.95	0.49	0.40

Intersection Summary

Area Type: Other
 Cycle Length: 140
 Actuated Cycle Length: 140
 Offset: 68 (49%), Referenced to phase 2:EBT and 6:WBT, Start of Green
 Natural Cycle: 150
 Control Type: Actuated-Coordinated
 Maximum v/c Ratio: 1.56
 Intersection Signal Delay: 100.8 Intersection LOS: F
 Intersection Capacity Utilization 114.4% ICU Level of Service H
 Analysis Period (min) 15
 ~ Volume exceeds capacity, queue is theoretically infinite.
 Queue shown is maximum after two cycles.
 # 95th percentile volume exceeds capacity, queue may be longer.
 Queue shown is maximum after two cycles.

Splits and Phases: 3: Prince of Wales Drive & West Hunt Club Road/Hunt Club Road



Lanes, Volumes, Timings
7: Prince of Wales Drive & Deakin Street

2175 Prince of Wales - 2030 AM - retail 70000 sqft
02/29/2024



Lane Group	EBL	EBR	NBL	NBT	SBT	SBR
Lane Configurations						
Traffic Volume (vph)	527	23	161	1287	582	417
Future Volume (vph)	527	23	161	1287	582	417
Ideal Flow (vphpl)	1800	1800	1800	1800	1800	1800
Storage Length (m)	70.0	0.0	100.0			0.0
Storage Lanes	1	0	1			0
Taper Length (m)	7.6		7.6			
Lane Util. Factor	0.97	0.95	1.00	0.95	0.95	0.95
Ped Bike Factor	1.00		1.00		0.99	
Frt	0.994				0.937	
Flt Protected	0.954		0.950			
Satd. Flow (prot)	3279	0	1695	3390	3144	0
Flt Permitted	0.954		0.252			
Satd. Flow (perm)	3272	0	449	3390	3144	0
Right Turn on Red		Yes				Yes
Satd. Flow (RTOR)	4				324	
Link Speed (k/h)	50			60	60	
Link Distance (m)	195.1			117.9	111.9	
Travel Time (s)	14.0			7.1	6.7	
Confl. Peds. (#/hr)	2	2	2			2
Peak Hour Factor	1.00	1.00	1.00	1.00	1.00	1.00
Adj. Flow (vph)	527	23	161	1287	582	417
Shared Lane Traffic (%)						
Lane Group Flow (vph)	550	0	161	1287	999	0
Turn Type	Prot		Perm	NA	NA	
Protected Phases	4			2	6	
Permitted Phases			2			
Detector Phase	4		2	2	6	
Switch Phase						
Minimum Initial (s)	1.0		5.0	5.0	5.0	
Minimum Split (s)	33.6		29.4	29.4	29.4	
Total Split (s)	33.6		67.0	67.0	67.0	
Total Split (%)	33.4%		66.6%	66.6%	66.6%	
Maximum Green (s)	27.0		60.6	60.6	60.6	
Yellow Time (s)	3.3		3.7	3.7	3.7	
All-Red Time (s)	3.3		2.7	2.7	2.7	
Lost Time Adjust (s)	0.0		0.0	0.0	0.0	
Total Lost Time (s)	6.6		6.4	6.4	6.4	
Lead/Lag						
Lead-Lag Optimize?						
Vehicle Extension (s)	3.0		3.0	3.0	3.0	
Recall Mode	None		C-Max	C-Max	C-Max	
Walk Time (s)	7.0		7.0	7.0	7.0	
Flash Dont Walk (s)	20.0		16.0	16.0	16.0	
Pedestrian Calls (#/hr)	2		2	2	2	
Act Effct Green (s)	21.8		65.8	65.8	65.8	
Actuated g/C Ratio	0.22		0.65	0.65	0.65	
v/c Ratio	0.77		0.55	0.58	0.46	
Control Delay	44.2		19.7	11.6	6.6	



Lane Group	EBL	EBR	NBL	NBT	SBT	SBR
Queue Delay	0.0		0.0	0.0	0.0	
Total Delay	44.2		19.7	11.6	6.6	
LOS	D		B	B	A	
Approach Delay	44.2			12.5	6.6	
Approach LOS	D			B	A	
Queue Length 50th (m)	47.7		14.1	61.3	26.4	
Queue Length 95th (m)	60.2		39.8	91.0	44.4	
Internal Link Dist (m)	171.1			93.9	87.9	
Turn Bay Length (m)	70.0		100.0			
Base Capacity (vph)	882		293	2215	2167	
Starvation Cap Reductn	0		0	0	0	
Spillback Cap Reductn	0		0	0	0	
Storage Cap Reductn	0		0	0	0	
Reduced v/c Ratio	0.62		0.55	0.58	0.46	

Intersection Summary

Area Type:	Other
Cycle Length:	100.6
Actuated Cycle Length:	100.6
Offset:	0 (0%), Referenced to phase 2:NBTL and 6:SBT, Start of Green
Natural Cycle:	80
Control Type:	Actuated-Coordinated
Maximum v/c Ratio:	0.77
Intersection Signal Delay:	16.4
Intersection LOS:	B
Intersection Capacity Utilization	73.8%
ICU Level of Service	D
Analysis Period (min)	15

Splits and Phases: 7: Prince of Wales Drive & Deakin Street



Intersection						
Int Delay, s/veh	0.6					
Movement	EBL	EBR	NBL	NBT	SBT	SBR
Lane Configurations		↗	↘	↑↑↑	↑↑↑	
Traffic Vol, veh/h	0	90	15	1820	957	84
Future Vol, veh/h	0	90	15	1820	957	84
Conflicting Peds, #/hr	20	20	20	0	0	20
Sign Control	Stop	Stop	Free	Free	Free	Free
RT Channelized	-	None	-	None	-	None
Storage Length	-	0	50	-	-	-
Veh in Median Storage, #	0	-	-	0	0	-
Grade, %	0	-	-	0	0	-
Peak Hour Factor	100	100	100	100	100	100
Heavy Vehicles, %	2	2	2	2	2	2
Mvmt Flow	0	90	15	1820	957	84

Major/Minor	Minor2	Major1	Major2		
Conflicting Flow All	-	561	1061	0	-
Stage 1	-	-	-	-	-
Stage 2	-	-	-	-	-
Critical Hdwy	-	7.14	5.34	-	-
Critical Hdwy Stg 1	-	-	-	-	-
Critical Hdwy Stg 2	-	-	-	-	-
Follow-up Hdwy	-	3.92	3.12	-	-
Pot Cap-1 Maneuver	0	403	366	-	-
Stage 1	0	-	-	-	-
Stage 2	0	-	-	-	-
Platoon blocked, %				-	-
Mov Cap-1 Maneuver	-	385	356	-	-
Mov Cap-2 Maneuver	-	-	-	-	-
Stage 1	-	-	-	-	-
Stage 2	-	-	-	-	-

Approach	EB	NB	SB
HCM Control Delay, s	17.2	0.1	0
HCM LOS	C		

Minor Lane/Major Mvmt	NBL	NBT	EBLn1	SBT	SBR
Capacity (veh/h)	356	-	385	-	-
HCM Lane V/C Ratio	0.042	-	0.234	-	-
HCM Control Delay (s)	15.6	-	17.2	-	-
HCM Lane LOS	C	-	C	-	-
HCM 95th %tile Q(veh)	0.1	-	0.9	-	-

Intersection						
Int Delay, s/veh	0.8					
Movement	WBL	WBR	NBT	NBR	SBL	SBT
Lane Configurations		↗ ↑↑↑	↗ ↑↑↑		↗ ↑	↗ ↑↑
Traffic Vol, veh/h	0	18	1800	15	50	985
Future Vol, veh/h	0	18	1800	15	50	985
Conflicting Peds, #/hr	0	0	0	0	0	0
Sign Control	Stop	Stop	Free	Free	Free	Free
RT Channelized	-	None	-	None	-	None
Storage Length	-	0	-	-	0	-
Veh in Median Storage, #	0	-	0	-	-	0
Grade, %	0	-	0	-	-	0
Peak Hour Factor	100	100	100	100	100	100
Heavy Vehicles, %	2	2	2	2	2	2
Mvmt Flow	0	18	1800	15	50	985

Major/Minor	Minor1	Major1	Major2		
Conflicting Flow All	-	908	0	0	1815
Stage 1	-	-	-	-	-
Stage 2	-	-	-	-	-
Critical Hdwy	-	7.14	-	-	5.34
Critical Hdwy Stg 1	-	-	-	-	-
Critical Hdwy Stg 2	-	-	-	-	-
Follow-up Hdwy	-	3.92	-	-	3.12
Pot Cap-1 Maneuver	0	239	-	-	155
Stage 1	0	-	-	-	-
Stage 2	0	-	-	-	-
Platoon blocked, %					
Mov Cap-1 Maneuver	-	239	-	-	155
Mov Cap-2 Maneuver	-	-	-	-	-
Stage 1	-	-	-	-	-
Stage 2	-	-	-	-	-

Approach	WB	NB	SB
HCM Control Delay, s	21.3	0	1.9
HCM LOS	C		

Minor Lane/Major Mvmt	NBT	NBRWBLn1	SBL	SBT
Capacity (veh/h)	-	-	239	155
HCM Lane V/C Ratio	-	-	0.075	0.323
HCM Control Delay (s)	-	-	21.3	38.9
HCM Lane LOS	-	-	C	E
HCM 95th %tile Q(veh)	-	-	0.2	1.3

Intersection						
Int Delay, s/veh	0.2					
Movement	WBL	WBR	NBT	NBR	SBL	SBT
Lane Configurations		↑ ↑ ↑	↑ ↑ ↑			↑ ↑ ↑
Traffic Vol, veh/h	0	28	1808	10	0	1035
Future Vol, veh/h	0	28	1808	10	0	1035
Conflicting Peds, #/hr	0	0	0	0	0	0
Sign Control	Stop	Stop	Free	Free	Free	Free
RT Channelized	-	None	-	None	-	None
Storage Length	-	0	-	-	-	-
Veh in Median Storage, #	0	-	0	-	-	0
Grade, %	0	-	0	-	-	0
Peak Hour Factor	100	100	100	100	100	100
Heavy Vehicles, %	2	2	2	2	2	2
Mvmt Flow	0	28	1808	10	0	1035

Major/Minor	Minor1	Major1	Major2		
Conflicting Flow All	-	909	0	0	-
Stage 1	-	-	-	-	-
Stage 2	-	-	-	-	-
Critical Hdwy	-	7.14	-	-	-
Critical Hdwy Stg 1	-	-	-	-	-
Critical Hdwy Stg 2	-	-	-	-	-
Follow-up Hdwy	-	3.92	-	-	-
Pot Cap-1 Maneuver	0	238	-	-	0
Stage 1	0	-	-	-	0
Stage 2	0	-	-	-	0
Platoon blocked, %			-	-	-
Mov Cap-1 Maneuver	-	238	-	-	-
Mov Cap-2 Maneuver	-	-	-	-	-
Stage 1	-	-	-	-	-
Stage 2	-	-	-	-	-

Approach	WB	NB	SB
HCM Control Delay, s	22.1	0	0
HCM LOS	C		

Minor Lane/Major Mvmt	NBT	NBRWBLn1	SBT
Capacity (veh/h)	-	-	238
HCM Lane V/C Ratio	-	-	0.118
HCM Control Delay (s)	-	-	22.1
HCM Lane LOS	-	-	C
HCM 95th %tile Q(veh)	-	-	0.4

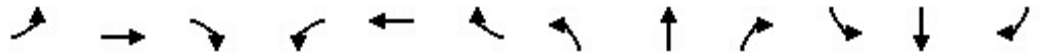

Lane Group	EBL	EBT	EBR	WBL	WBT	WBR	NBL	NBT	NBR	SBL	SBT	SBR
Lane Configurations	↖↗	↕	↖	↖↗	↕	↖	↖	↕	↖	↖↗	↕	↖
Traffic Volume (vph)	106	1108	63	680	1273	353	95	511	844	463	892	120
Future Volume (vph)	106	1108	63	680	1273	353	95	511	844	463	892	120
Ideal Flow (vphpl)	1800	1800	1800	1800	1800	1800	1800	1800	1800	1800	1800	1800
Lane Width (m)	3.7	3.5	4.8	3.7	3.5	3.7	3.7	3.5	4.8	3.7	3.5	3.5
Storage Length (m)	125.0		150.0	150.0		100.0	50.0		0.0	125.0		200.0
Storage Lanes	2		1	2		1	1		1	2		1
Taper Length (m)	7.6			7.6			7.6			7.6		
Lane Util. Factor	0.97	0.95	1.00	0.97	0.95	1.00	1.00	0.95	1.00	0.97	0.95	1.00
Ped Bike Factor	1.00		0.98	1.00		0.98	1.00		0.98	1.00		0.98
Fr _t			0.850			0.850			0.850			0.850
Fl _t Protected	0.950			0.950			0.950			0.950		
Satd. Flow (prot)	3288	3283	1651	3321	3252	1488	1729	3316	1717	3195	3349	1455
Fl _t Permitted	0.950			0.950			0.950			0.950		
Satd. Flow (perm)	3286	3283	1626	3318	3252	1464	1727	3316	1690	3185	3349	1432
Right Turn on Red			Yes			Yes			Yes			Yes
Satd. Flow (RTOR)			218			352			218			170
Link Speed (k/h)		80			80			60				60
Link Distance (m)		187.8			279.7			97.7				205.8
Travel Time (s)		8.5			12.6			5.9				12.3
Confl. Peds. (#/hr)	2		2	2		2	2		2	2		2
Peak Hour Factor	1.00	1.00	1.00	1.00	1.00	1.00	1.00	1.00	1.00	1.00	1.00	1.00
Heavy Vehicles (%)	2%	3%	5%	1%	4%	4%	0%	2%	1%	5%	1%	4%
Adj. Flow (vph)	106	1108	63	680	1273	353	95	511	844	463	892	120
Shared Lane Traffic (%)												
Lane Group Flow (vph)	106	1108	63	680	1273	353	95	511	844	463	892	120
Turn Type	Prot	NA	Perm	Prot	NA	Perm	Prot	NA	Perm	Prot	NA	Perm
Protected Phases	5	2		1	6		7	4		3	8	
Permitted Phases			2			6			4			8
Detector Phase	5	2	2	1	6	6	7	4	4	3	8	8
Switch Phase												
Minimum Initial (s)	5.0	5.0	5.0	5.0	5.0	5.0	5.0	5.0	5.0	5.0	5.0	5.0
Minimum Split (s)	11.6	30.6	30.6	11.6	31.6	31.6	11.6	30.6	30.6	11.6	31.6	31.6
Total Split (s)	15.0	63.0	63.0	28.0	76.0	76.0	13.0	31.0	31.0	28.0	46.0	46.0
Total Split (%)	10.0%	42.0%	42.0%	18.7%	50.7%	50.7%	8.7%	20.7%	20.7%	18.7%	30.7%	30.7%
Maximum Green (s)	8.4	56.4	56.4	21.4	69.4	69.4	6.4	24.4	24.4	21.4	39.4	39.4
Yellow Time (s)	3.7	3.7	3.7	3.7	3.7	3.7	3.7	3.7	3.7	3.7	3.7	3.7
All-Red Time (s)	2.9	2.9	2.9	2.9	2.9	2.9	2.9	2.9	2.9	2.9	2.9	2.9
Lost Time Adjust (s)	0.0	0.0	0.0	0.0	0.0	0.0	0.0	0.0	0.0	0.0	0.0	0.0
Total Lost Time (s)	6.6	6.6	6.6	6.6	6.6	6.6	6.6	6.6	6.6	6.6	6.6	6.6
Lead/Lag	Lead	Lag	Lag	Lead	Lag	Lag	Lead	Lag	Lag	Lead	Lag	Lag
Lead-Lag Optimize?	Yes	Yes	Yes	Yes	Yes	Yes	Yes	Yes	Yes	Yes	Yes	Yes
Vehicle Extension (s)	3.0	3.0	3.0	3.0	3.0	3.0	3.0	3.0	3.0	3.0	3.0	3.0
Recall Mode	None	C-Max	C-Max	None	C-Max	C-Max	None	Max	Max	None	Max	Max
Walk Time (s)		7.0	7.0		7.0	7.0		7.0	7.0		7.0	7.0
Flash Dont Walk (s)		17.0	17.0		18.0	18.0		17.0	17.0		18.0	18.0
Pedestrian Calls (#/hr)		2	2		2	2		2	2		2	2
Act Effct Green (s)	8.2	56.4	56.4	21.4	69.6	69.6	6.4	24.4	24.4	21.4	39.4	39.4
Actuated g/C Ratio	0.05	0.38	0.38	0.14	0.46	0.46	0.04	0.16	0.16	0.14	0.26	0.26

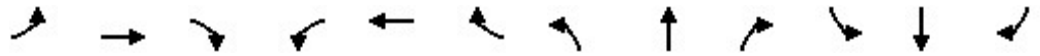

Lane Group	EBL	EBT	EBR	WBL	WBT	WBR	NBL	NBT	NBR	SBL	SBT	SBR
v/c Ratio	0.59	0.90	0.08	1.44	0.84	0.41	1.30	0.95	1.85	1.02	1.01	0.24
Control Delay	83.1	54.8	0.2	252.5	41.9	3.7	257.9	89.4	414.0	108.9	88.0	2.4
Queue Delay	0.0	0.0	0.0	0.0	0.0	0.0	0.0	0.0	0.0	0.0	0.0	0.0
Total Delay	83.1	54.8	0.2	252.5	41.9	3.7	257.9	89.4	414.0	108.9	88.0	2.4
LOS	F	D	A	F	D	A	F	F	F	F	F	A
Approach Delay		54.5			98.2			289.4				87.6
Approach LOS		D			F			F				F
Queue Length 50th (m)	14.8	149.9	0.0	~129.7	159.7	0.2	~33.0	73.8	~299.2	~68.8	~135.1	0.0
Queue Length 95th (m)	24.3	#179.1	0.0	#165.1	188.8	15.9	#68.2	#105.8	#371.7	#100.7	#173.4	3.5
Internal Link Dist (m)		163.8			255.7			73.7				181.8
Turn Bay Length (m)	125.0		150.0	150.0		100.0	50.0			125.0		200.0
Base Capacity (vph)	184	1234	747	473	1509	868	73	539	457	455	879	501
Starvation Cap Reductn	0	0	0	0	0	0	0	0	0	0	0	0
Spillback Cap Reductn	0	0	0	0	0	0	0	0	0	0	0	0
Storage Cap Reductn	0	0	0	0	0	0	0	0	0	0	0	0
Reduced v/c Ratio	0.58	0.90	0.08	1.44	0.84	0.41	1.30	0.95	1.85	1.02	1.01	0.24

Intersection Summary

Area Type: Other
 Cycle Length: 150
 Actuated Cycle Length: 150
 Offset: 31 (21%), Referenced to phase 2:EBT and 6:WBT, Start of Green
 Natural Cycle: 150
 Control Type: Actuated-Coordinated
 Maximum v/c Ratio: 1.85
 Intersection Signal Delay: 129.8 Intersection LOS: F
 Intersection Capacity Utilization 118.2% ICU Level of Service H
 Analysis Period (min) 15
 ~ Volume exceeds capacity, queue is theoretically infinite.
 Queue shown is maximum after two cycles.
 # 95th percentile volume exceeds capacity, queue may be longer.
 Queue shown is maximum after two cycles.

Splits and Phases: 3: Prince of Wales Drive & West Hunt Club Road/Hunt Club Road

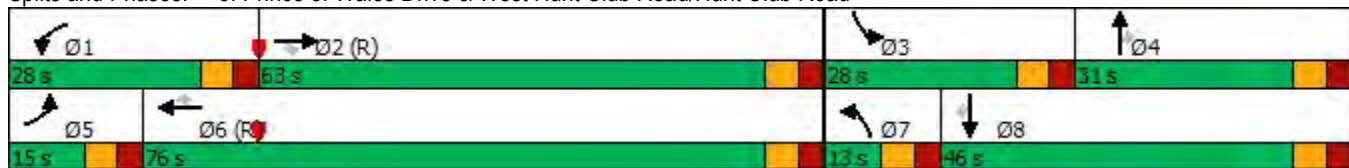

Lanes, Volumes, Timings
7: Prince of Wales Drive & Deakin Street

2175 Prince of Wales - 2030 PM - retail 70000 sqft

03/01/2024



Lane Group	EBL	EBR	NBL	NBT	SBT	SBR
Lane Configurations						
Traffic Volume (vph)	498	191	35	831	1398	183
Future Volume (vph)	498	191	35	831	1398	183
Ideal Flow (vphpl)	1800	1800	1800	1800	1800	1800
Storage Length (m)	70.0	0.0	100.0			0.0
Storage Lanes	1	0	1			0
Taper Length (m)	7.6		7.6			
Lane Util. Factor	0.97	0.95	1.00	0.95	0.95	0.95
Ped Bike Factor	0.95				0.99	
Fr _t	0.958				0.983	
Fl _t Protected	0.965		0.950			
Satd. Flow (prot)	3124	0	1729	3390	3317	0
Fl _t Permitted	0.965		0.105			
Satd. Flow (perm)	3034	0	191	3390	3317	0
Right Turn on Red		Yes				Yes
Satd. Flow (RTOR)	45				26	
Link Speed (k/h)	50			60	60	
Link Distance (m)	195.1			117.9	111.9	
Travel Time (s)	14.0			7.1	6.7	
Confl. Peds. (#/hr)	20	20	20			20
Peak Hour Factor	1.00	1.00	1.00	1.00	1.00	1.00
Heavy Vehicles (%)	2%	2%	0%	2%	1%	5%
Adj. Flow (vph)	498	191	35	831	1398	183
Shared Lane Traffic (%)						
Lane Group Flow (vph)	689	0	35	831	1581	0
Turn Type	Prot		Perm	NA	NA	
Protected Phases	4			2	6	
Permitted Phases			2			
Detector Phase	4		2	2	6	
Switch Phase						
Minimum Initial (s)	5.0		5.0	5.0	5.0	
Minimum Split (s)	24.6		24.4	24.4	24.4	
Total Split (s)	33.0		87.0	87.0	87.0	
Total Split (%)	27.5%		72.5%	72.5%	72.5%	
Maximum Green (s)	26.4		80.6	80.6	80.6	
Yellow Time (s)	3.3		3.7	3.7	3.7	
All-Red Time (s)	3.3		2.7	2.7	2.7	
Lost Time Adjust (s)	0.0		0.0	0.0	0.0	
Total Lost Time (s)	6.6		6.4	6.4	6.4	
Lead/Lag						
Lead-Lag Optimize?						
Vehicle Extension (s)	3.0		3.0	3.0	3.0	
Recall Mode	None		C-Max	C-Max	C-Max	
Walk Time (s)	7.0		7.0	7.0	7.0	
Flash Dont Walk (s)	11.0		11.0	11.0	11.0	
Pedestrian Calls (#/hr)	0		0	0	0	
Act Effct Green (s)	26.3		80.7	80.7	80.7	
Actuated g/C Ratio	0.22		0.67	0.67	0.67	
v/c Ratio	0.96		0.27	0.36	0.71	



Lane Group	EBL	EBR	NBL	NBT	SBT	SBR
Control Delay	67.9		14.5	9.1	14.2	
Queue Delay	0.0		0.0	0.0	0.0	
Total Delay	67.9		14.5	9.1	14.2	
LOS	E		B	A	B	
Approach Delay	67.9			9.3	14.2	
Approach LOS	E			A	B	
Queue Length 50th (m)	72.2		2.8	37.6	101.3	
Queue Length 95th (m)	#105.9		8.8	47.3	123.6	
Internal Link Dist (m)	171.1			93.9	87.9	
Turn Bay Length (m)	70.0		100.0			
Base Capacity (vph)	722		128	2278	2238	
Starvation Cap Reductn	0		0	0	0	
Spillback Cap Reductn	0		0	0	0	
Storage Cap Reductn	0		0	0	0	
Reduced v/c Ratio	0.95		0.27	0.36	0.71	

Intersection Summary

Area Type: Other
 Cycle Length: 120
 Actuated Cycle Length: 120
 Offset: 0 (0%), Referenced to phase 2:NBTL and 6:SBT, Start of Green
 Natural Cycle: 65
 Control Type: Actuated-Coordinated
 Maximum v/c Ratio: 0.96
 Intersection Signal Delay: 24.7
 Intersection LOS: C
 Intersection Capacity Utilization 79.9%
 ICU Level of Service D
 Analysis Period (min) 15
 # 95th percentile volume exceeds capacity, queue may be longer.
 Queue shown is maximum after two cycles.

Splits and Phases: 7: Prince of Wales Drive & Deakin Street

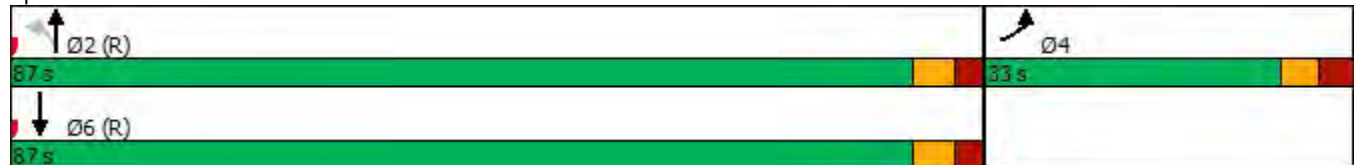

Intersection						
Int Delay, s/veh	0.3					
Movement	EBL	EBR	NBL	NBT	SBT	SBR
Lane Configurations		↗	↘	↑↑↑	↑↑↑	
Traffic Vol, veh/h	0	36	6	1450	1663	32
Future Vol, veh/h	0	36	6	1450	1663	32
Conflicting Peds, #/hr	20	20	20	0	0	20
Sign Control	Stop	Stop	Free	Free	Free	Free
RT Channelized	-	None	-	None	-	None
Storage Length	-	0	50	-	-	-
Veh in Median Storage, #	0	-	-	0	0	-
Grade, %	0	-	-	0	0	-
Peak Hour Factor	100	100	100	100	100	100
Heavy Vehicles, %	2	2	2	2	2	2
Mvmt Flow	0	36	6	1450	1663	32

Major/Minor	Minor2	Major1	Major2			
Conflicting Flow All	-	888	1715	0	-	0
Stage 1	-	-	-	-	-	-
Stage 2	-	-	-	-	-	-
Critical Hdwy	-	7.14	5.34	-	-	-
Critical Hdwy Stg 1	-	-	-	-	-	-
Critical Hdwy Stg 2	-	-	-	-	-	-
Follow-up Hdwy	-	3.92	3.12	-	-	-
Pot Cap-1 Maneuver	0	246	174	-	-	-
Stage 1	0	-	-	-	-	-
Stage 2	0	-	-	-	-	-
Platoon blocked, %				-	-	-
Mov Cap-1 Maneuver	-	235	169	-	-	-
Mov Cap-2 Maneuver	-	-	-	-	-	-
Stage 1	-	-	-	-	-	-
Stage 2	-	-	-	-	-	-

Approach	EB	NB	SB
HCM Control Delay, s	23.1	0.1	0
HCM LOS	C		

Minor Lane/Major Mvmt	NBL	NBT	EBLn1	SBT	SBR
Capacity (veh/h)	169	-	235	-	-
HCM Lane V/C Ratio	0.036	-	0.153	-	-
HCM Control Delay (s)	27.1	-	23.1	-	-
HCM Lane LOS	D	-	C	-	-
HCM 95th %tile Q(veh)	0.1	-	0.5	-	-

Intersection						
Int Delay, s/veh	1.5					
Movement	WBL	WBR	NBT	NBR	SBL	SBT
Lane Configurations		↑↑↑	↑↑↑		↑	↑↑
Traffic Vol, veh/h	0	74	1295	36	119	1581
Future Vol, veh/h	0	74	1295	36	119	1581
Conflicting Peds, #/hr	0	0	0	0	0	0
Sign Control	Stop	Stop	Free	Free	Free	Free
RT Channelized	-	None	-	None	-	None
Storage Length	-	0	-	-	0	-
Veh in Median Storage, #	0	-	0	-	-	0
Grade, %	0	-	0	-	-	0
Peak Hour Factor	100	100	100	100	100	100
Heavy Vehicles, %	2	2	2	2	2	2
Mvmt Flow	0	74	1295	36	119	1581

Major/Minor	Minor1	Major1	Major2
Conflicting Flow All	-	666	0
Stage 1	-	-	-
Stage 2	-	-	-
Critical Hdwy	-	7.14	-
Critical Hdwy Stg 1	-	-	-
Critical Hdwy Stg 2	-	-	-
Follow-up Hdwy	-	3.92	-
Pot Cap-1 Maneuver	0	345	-
Stage 1	0	-	-
Stage 2	0	-	-
Platoon blocked, %		-	-
Mov Cap-1 Maneuver	-	345	-
Mov Cap-2 Maneuver	-	-	-
Stage 1	-	-	-
Stage 2	-	-	-

Approach	WB	NB	SB
HCM Control Delay, s	18.3	0	2
HCM LOS	C		

Minor Lane/Major Mvmt	NBT	NBRWBLn1	SBL	SBT
Capacity (veh/h)	-	-	345	270
HCM Lane V/C Ratio	-	-	0.214	0.441
HCM Control Delay (s)	-	-	18.3	28.4
HCM Lane LOS	-	-	C	D
HCM 95th %tile Q(veh)	-	-	0.8	2.1

Intersection

Int Delay, s/veh 0.7

Movement	WBL	WBR	NBT	NBR	SBL	SBT
Lane Configurations		↑↑↑	↑↑↑			↑↑↑
Traffic Vol, veh/h	0	111	1345	24	0	1700
Future Vol, veh/h	0	111	1345	24	0	1700
Conflicting Peds, #/hr	0	0	0	0	0	0
Sign Control	Stop	Stop	Free	Free	Free	Free
RT Channelized	-	None	-	None	-	None
Storage Length	-	0	-	-	-	-
Veh in Median Storage, #	0	-	0	-	-	0
Grade, %	0	-	0	-	-	0
Peak Hour Factor	100	100	100	100	100	100
Heavy Vehicles, %	2	2	2	2	2	2
Mvmt Flow	0	111	1345	24	0	1700

Major/Minor

	Minor1	Major1	Major2		
Conflicting Flow All	-	685	0	0	-
Stage 1	-	-	-	-	-
Stage 2	-	-	-	-	-
Critical Hdwy	-	7.14	-	-	-
Critical Hdwy Stg 1	-	-	-	-	-
Critical Hdwy Stg 2	-	-	-	-	-
Follow-up Hdwy	-	3.92	-	-	-
Pot Cap-1 Maneuver	0	335	-	-	0
Stage 1	0	-	-	-	0
Stage 2	0	-	-	-	0
Platoon blocked, %			-	-	-
Mov Cap-1 Maneuver	-	335	-	-	-
Mov Cap-2 Maneuver	-	-	-	-	-
Stage 1	-	-	-	-	-
Stage 2	-	-	-	-	-

Approach

	WB	NB	SB
HCM Control Delay, s	21	0	0
HCM LOS	C		

Minor Lane/Major Mvmt

	NBT	NBRWBLn1	SBT
Capacity (veh/h)	-	-	335
HCM Lane V/C Ratio	-	-	0.331
HCM Control Delay (s)	-	-	21
HCM Lane LOS	-	-	C
HCM 95th %tile Q(veh)	-	-	1.4

APPENDIX “K”

CITY STAFF COMMENT RESPONSES

I - Screening and Scoping Comments and Responses:

Transportation Engineering Services

Section 2.1.1 Proposed Development:

Clarify whether the development will be limited to one of the four envisioned alternative land uses, or whether a combination of land uses is also possible.

Response:

The purpose of the submission, at this point in time, is to apply for zoning amendment that would permit any of the individual land uses considered. However, your point is appreciated, in that a combination of the land uses could well result in more traffic than any single use that was considered. We believe that, should the chosen land use include a mix of individual uses, the City is well within its rights of imposing a condition that would assure that once site plan approval is to be requested, a new updated TIA evaluation would be required that would address a proposed mixed-use development, if applicable.

Section 2.1.2.1 Study Area Roadways:

Please add ROW protection (per Schedule C16 of the Official Plan) to Table 2-1.

Response:

The section 2.1.2.1 of forthcoming Strategy Report has been modified to include a discussion on the right-of-way to be protected along Prince of Wales, Hunt Club Road and Deakin Street, as described in Schedule C16 of the OP.

Road	From	To	ROW to be Protected (m)	Classification	Sector
Deakin	Auriga	Prince of Wales	24	collector	urban
Hunt Club	Prince of Wales	Conroy	44.5	arterial	urban
West Hunt Club	Cleopatra	Prince of Wales	44.5	arterial	urban

The description of the northbound approach of the Prince of Wales Drive / Deakin Street intersection is incorrect: there are two northbound through lanes and one auxiliary northbound left turn lane.

Response:

This has been corrected in section 2.1.2.2 of the forthcoming Strategy Report.

The description of the receiving lanes are wrong.

Response:

The description of receiving lanes has been corrected and cleared up in section 2.1.2.2 of the forthcoming Strategy Report.

Move discussion of the Prince of Wales Drive / Esso Service Station Access intersection to Section 2.1.2.3.

Response:

The discussion has been moved from section 2.1.2.2 to 2.1.2.3 in the forthcoming Strategy Report.

Section 2.1.2.3 Existing Surrounding Driveways:

Note the right-in / right-out access control of the two Prince of Wales Drive accesses to the Metropolitan Bible Church.

Response:

The Metropolitan Bible Church accesses have been elaborated on in section 2.1.2.3 of the forthcoming Strategy Report.

Section 2.1.2.4 Existing Pedestrian Facilities:

Note that pedestrian may use the paved shoulders / asphalt pathways provided on either side of Prince of Wales Drive within the study area.

Response:

This has been added to the pedestrian facilities section (2.1.2.4) in the forthcoming Strategy Report.

Section 2.1.2.6 Existing Transit Provisions:

Bus stop ID: 1601 for Route 187, located just to the south of Deakin Street/Prince of Wales Drive intersection, is missing from the Section 2.1.2.6 discussion, and missing from Exhibit 2-9. Please correct.

Response:

Stop 1601 has been added to the text and Exhibit 2-9 has been updated (and the source and date of information therein noted as a footnote) in section 2.1.2.6 of the forthcoming Strategy Report.

Table 2-3:

The 'Type', 'Terminus 1', 'Terminus 2', 'Headways', and 'Notes' information for all routes in Table 2-3 is incorrect. Please review and fix. Include a row within the table for Route 199

Response:

Noted: Route 199 in Table 2-3 has been added and Table 2-3 has been updated (and the source and date of information therein noted as a footnote) in section 2.1.2.6 the forthcoming Strategy Report.

Section 2.1.2.8 Existing Peak Hour Travel Demands by Mode:

State whether the volume balancing along Prince of Wales Drive assumes that traffic to/from the Metropolitan Bible Church is minimal.

Response:

The following statement has been added to Section 2.1.2.8. of the forthcoming Strategy Report: *“Weekday traffic generation associated with the Metropolitan Bible Church was for the purpose of this study assumed to be negligible. Exhibit 2-12: Balanced Morning and Afternoon Peak Hour Traffic Volumes illustrates no effects upon the southbound traffic volumes associated with the two right-in-right-out accesses. This was observed during the time of the traffic count.”*

Section 2.1.2.9 Road Safety

Evaluate whether there are any discernable patterns in angle and sideswipe collisions at the Hunt Club Road and Prince of Wales Drive intersection.

Response:

The following statement has been added to section 2.1.2.9 of the Strategy Report: *“ Of the 141 reported incidents at the Hunt Club Roads/Prince of Wales Drive the following findings were evident:*

The 91 rear end collisions at the intersection were split roughly evenly on each approach to the intersection indicating no discernable pattern;

The 13 angled collisions that occurred over the 5 year period do not represent a significant enough sample to indicate any discernable pattern. The 13 incidents were found to be roughly distributed among all 4 approach directions;

Similarly, the 29 sideswipe incidents that occurred over the same 5 year period split roughly evenly on each approach to the intersection indicating no discernable pattern.”

Include the number of collisions involving cyclists within Table 2-8 and Table 2-9.

Response:

The following statement has been added to section 2.1.2.9 of the Strategy Report: “*The following two cycling incidents, both of which resulted in non-fatal injuries, were reported within the five year period analyzed:*

In 2018, a southbound cyclist on the west side of Prince of Wales Drive was struck by a northbound motor-vehicle making a left turn onto Deakin Street which failed to yield the right-of-way.

In 2019, a westbound cyclist travelling on the south side of West Hunt Club Road was struck by a northbound motor-vehicle making a right turn which failed to yield the right-of-way.

The small sample of reported cycling incidents do not present any trends or discernable patterns.”

Section 2.2.1 Study Area:

Waterbend Lane is a boundary street. Include Waterbend Lane as a study area roadway.

Response:

Section 2.1.2 has been modified to include descriptive text describing Waterbend Lane, and the Waterbend Lane access onto Prince of Wales Drive

Section 2.3 Exemption Request:

Please use the updated exemption table from the 2023 revisions to the TIA Guideline (https://documents.ottawa.ca/sites/documents/files/tia_revisions_en.pdf).

Response:

Table 2-1 in section 2.3 has been revised to comply with the 2023 revisions of the TIA Guidelines.

Include all network impact modules.

Response:

Agreed: The request to remove/exempt Module 4.8 Network Elements has been removed from Table 2-10 in section 2.3. This module will be addressed under Section 4.5 & 4.6 & 4.8 within the Strategy Report.

Section 3.1.1.2 Person Trips and Mode Shares

The TIA guidelines recommend identifying the base mode share and then set mode share targets. Please reference the source of the base mode shares.

Note employment generator modes shares in Table 12 and commercial generator mode shares in Table 13 for Merivale District in the TRANS 2020 Trip Generation Manual.

Response:

Section 3.1.1.2 has been redrafted and now references the TRANS 2020 Trip Generation Manual and the approach taken to derive the mode share that was applied within the scoping document.

Assignment:

The retail plaza land use's PM peak hour vehicle trip generation in Table 3-6 is inconstant with Table 3-3. Please explain. Is the lower number in Table 3-6 due to application of a pass-by trip reduction that is not discussed in the text?

Response:

Section 3.1.3, Table 3-6 had an error in the last row indicating afternoon peak hour results. The error has been corrected in the forthcoming Strategy Report. The study assumed no reduction for pass-by or shared trips. The values used for analysis were referenced directly from Table 3-3. Thank you for pointing out this error.

Preliminary Comments on the Proposed Access Concept (Appendix D):

Note the Prince of Wales Environmental Assessment Report generally endorsed Prince of Wales accesses to be consolidated/minimized and remove full movement accesses in favour of right-in / right-out accesses.

Response:

The City of Ottawa's preference to right-in, right-out accesses is noted. However, given that 67% of the traffic headed into the proposed development (based on the existing auto dealership's customer addresses) would originate from the north, there is a significant need to accommodate left turns into the site from the north providing entry via Access 1. It should be kept in mind that Inbound traffic making a U-turn at the Deakin Street intersection or the Waterbend Lane access was considered to be more disruptive to north-south thru movements than providing for a properly designed southbound left-turn lane. In addition, for a site this size (8+ acres) and recognizing there is to be no access on Waterbend, two accesses are necessary to assure project viability.

Also note Official Plan policy 4.1.2.4, which recommends limiting points of conflicts for vehicle access across an existing or planned cycling facility. Prince of Wales Drive includes existing cycling facilities and is a crosstown bikeway. Look at options to consolidate the accesses on Prince of Wales Drive.

Response:

The applicant's preference is to provide two accesses to the property from Prince of Wales Drive. It is our understanding from the Prince of Wales Drive EA that a multi-use pathway is envisioned along the east side of the Prince of Wales Drive corridor. At the time of functional planning, access designs are to incorporate the most current City of Ottawa design standards aimed at assuring both pedestrian and cyclist safety. Consolidation of the two accesses for a site this size to a single access will jeopardize the project.

Confirm the proposed access(es) will meet the requirements of Section 25 of the Private Approach By-Law, including Section 25 (1) (m).

Response:

It was confirmed that the distance between the proposed two accesses to the site is 100m and the distance between Access 2 and Waterbend Lane is 75m. This separation exceeds all the requirements detailed in any of the parking supply levels noted in Section 25 (1) (m) of the Private Approach By-Law.

The "pork chop" island utilized within Access 2 is not recommended. Left turn movements are already restricted by the median. The pork chop only serves to widen the access, increase corner radii, and increase vehicle turning speeds.

Response:

The City's preference not to use pork chop islands at the accesses is understood. In the case of (North) Access 2, we completely concur with the City's position. The pork chop will be removed from the current design sketches prior to submission of the Strategy Report. Please see below exhibits as an early draft of refinements that are being considered. The inbound curve radius has been reduced from 18.5 m to 11.5 m. Please note the departure radius was modified to accommodate car carrier

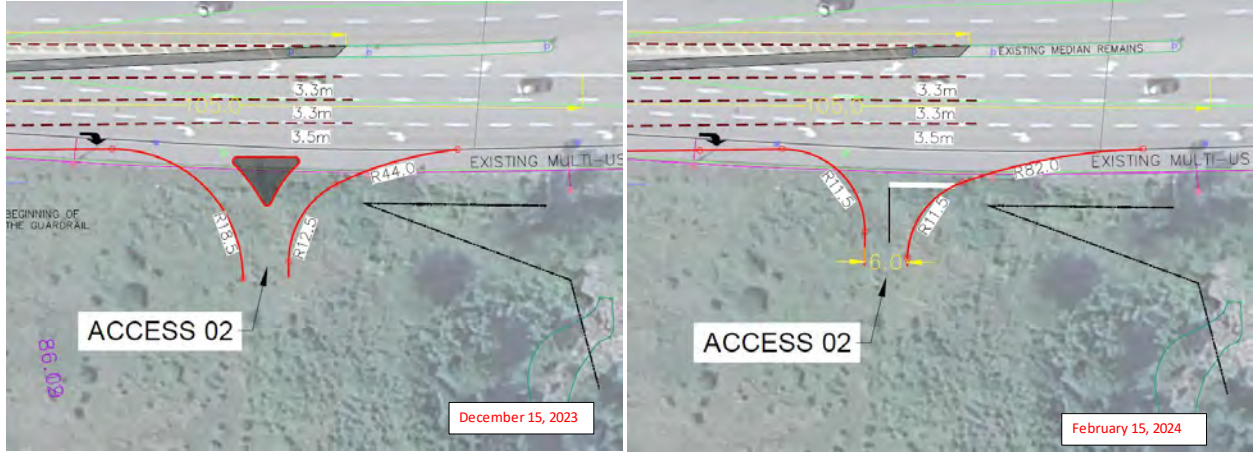

trucks exiting the site. Please let us know if you concur with what is proposed or if further investigation is needed.

See below: previous Access 2 concept dated December 15, 2023 (left); Proposed access concept dated February 15, 2024 (right)

The “pork chop” island utilized within Access 1 should also be evaluated to see if it can be removed. Consider whether the left-out movement can be effectively discouraged by use of a shaped centre median (similar shape as the nearby Esso Service Station access).

Response:

The City’s preference to not utilize pork chop islands at the accesses is understood. However, in case of the (South) Access No. 1, we believe the pork chop is necessary to effectively restrict the left-turns out of the site.

The shaped centre median used at the Esso Service Station access that was referred above works effectively in conjunction with a raised pork chop island also present at the access (See StreetView Picture below). It is believed that the shaped median alone will not be sufficient to discourage left turns out of the site. Unrestricted illegal left turns across the Prince of Wales corridor may pose a safety risk.

The best compromise that we are able to find at the time is narrowing the proposed pork chop island, as illustrated on the exhibit below dated Feb 15th, 2024. Note that the larger curve radius on approach is required to accommodate car carrier trucks entering into the site from both north and south directions on POW. If you have any suggestions for us to investigate alternative solutions to facilitate safe circulation at this access, please let us know.

See below: the previous Access 1 concept dated December 15, 2023 (left); Proposed access concept dated February 15, 2024 (right)

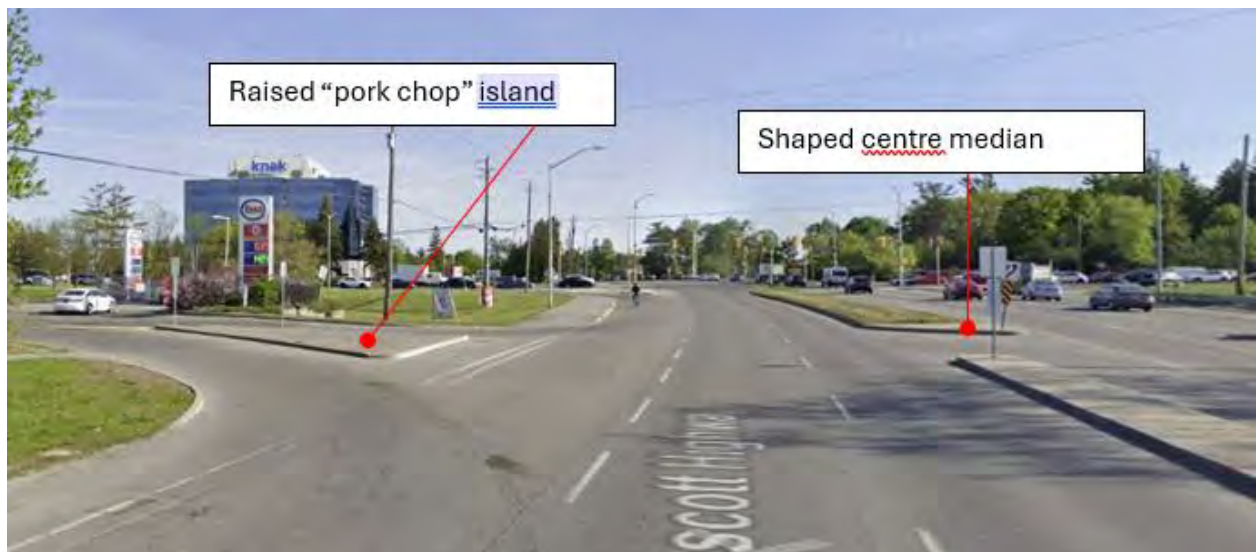

The proposed modifications to Prince of Wales Drive displace the existing paved shoulder / pathway on the east side of Prince of Wales Drive between Deakin Street and Hunt Club Road. Replacement sidewalk and cycle track must be provided per

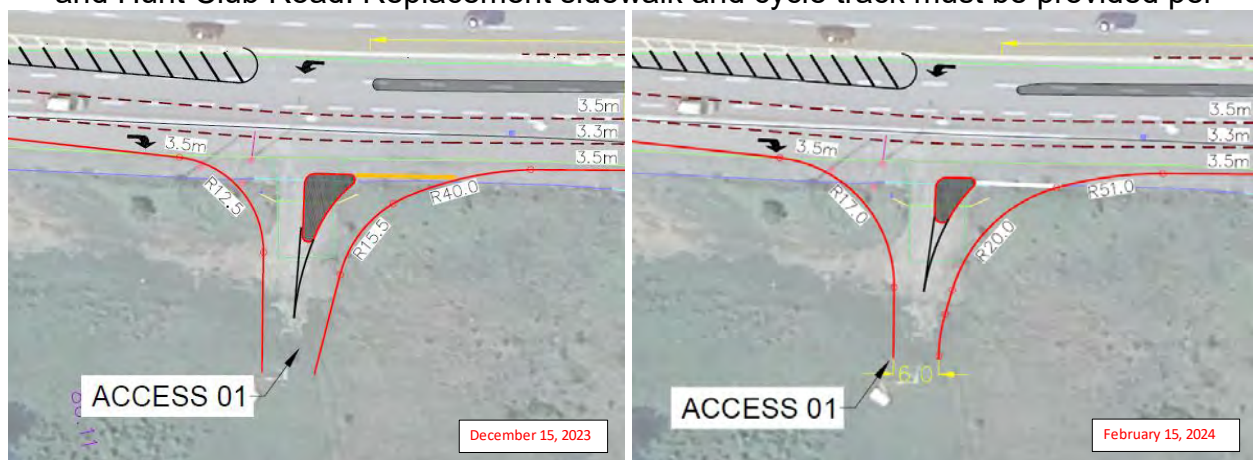

the latest City of Ottawa standards.

Response:

This is understood as we proceed to the Strategy Report and on to functional planning.

A Roadway Modification Approval (RMA) report will be required for the proposed modifications to Prince of Wales Drive.

Response:

This has been communicated to the Client. Could you please confirm if an RMA is required at the zoning stage or can be delayed until site plan approval? Could you also please acknowledge if the Client would be permitted to implement the modifications to Prince of Wales Drive prior to the site plan approval?

Traffic Engineering

Traffic analysis should be extended to also include the intersection of Hunt Club Road & Riverside Drive.

Response:

We have requested an exemption from this analysis (response received from you on January 22, 2024) at the current Zoning Amendment stage, given that our preliminary analysis focused on only the nearby Prince of Wales Drive / Hunt Club and Prince of Wales Drive / Deakin intersections. The client was informed that analysis of Hunt Club / Riverside intersection will likely be required upon the site plan approval stage.

Concerns with anticipated spillbacks to the site entrances with northbound traffic and proximity to overcapacity intersections.

Response:

This concern is acknowledged and will be fully addressed within the forthcoming strategy Report.

II – Strategy Report Comments and responses:

Transportation Engineering Services

Section 2.1.2.3 Existing Surrounding Driveways:

In Table 2-2, there is a reference error in the description of the driveway at 2162 Prince of Wales Drive “(see section 0, intersection 3)”. Please correct section reference.

Simple corrections have been made where required.

Section 2.1.3.1 Changes to the Study Area Transportation Network:

Show the functional design plan from the Prince of Wales Environmental Study Report for this segment of Prince of Wales Drive and clearly show the ROW Protection of Prince of Wales Drive. Note Pages 215, 216 of said report for Plates 23, 24.

Response: Official Plan – Schedule C-16 indicates that the “ROW width for Prince of Wales Drive between Deakin Road to West Hunt Club varies and subject to the unequal widening requirements of the POW ESR between 40 and 48m.” Could you please provide the CAD files for Plates 23 and 24 so we can “clearly show the ROW protection of Prince of Wales Drive indicated in the ESR on Plates 23, 24, in time for a revamp of the TIA document once a specific land use has been adopted.

Note: The comments to Section 4.3 that were provided indicated that “a multi-use pathway per the Prince of Wales Drive EA is no longer the recommended facility per Official Plan and Transportation Master Plan policy” and that “Transportation Engineering Services comments require that the displaced paved shoulder / pathway on the east side of Prince of Wales Drive be replaced with a sidewalk and cycle track per City of Ottawa standards.” The required right-of-way” to accomplish this new design will vary from that indicated in the POW ESR document which may no longer be applicable. It is understood that this application is only for zoning and a functional plan detailing this new infrastructure will be required prior to defining the required ROW.

Section 4.1.1. Design For Sustainable Modes:

The TDM-Supportive Development Design and Infrastructure Checklist is currently empty. A completed TDM-Supportive Development Design and Infrastructure Checklist must be provided.

Response: We are dealing with multiple different land uses to get us through zoning approvals. This submission is to be completed once the land use has been clearly defined. A site plan is not available for any of these land uses being considered at this time. This would be completed at the time of site plan submission.

Section 4.1.2 Circulation and Access, Section 4.4 Access Intersections, and Section 4.9.3 Access Operations:

The requirement for two accesses on Prince of Wales Drive for car carrier circulation is understood. However, if one of the other contemplated land uses are ultimately proposed during site plan control, then...

- consolidation of the site accesses should be reconsidered, and

- the use of Waterbend Lane for site access should be reconsidered.

Response: We agree. Consolidation of accesses and the use of Waterbend Lane will be reconsidered if a land use other than an auto dealership is to be ultimately put forth during site plan control. We will only know this when a final land use has been selected.

In Appendix G, provide two sheets – one for HSU movements and one for car carrier movements.

Response: As requested, please find attached an exhibit [04-POW – HSU Turning movements.pdf] that illustrates the turning movements associated with a heavy single unit truck (HSU). As requested, this has been include within Appendix “G”. The previous exhibit contained in Appendix G illustrates, only where necessary, the turning movements associated with a car carrier which would be a northbound right turn or southbound left turn at the south access (No. 1) and a right turn out of the site at the north access (No. 2).

As the car carrier is considered an infrequent large control vehicle, it may be assumed to have the following turning parameters (per the City of Toronto Curb Radii Guidelines):

- For right-turns entering the site:
 - Commence right-turns into the site from a position in the adjacent through lane. **Response:** Should the auto dealership land use be selected as the preferred land use to go forward to site plan approval, this option will be considered. [However using the adjacent through lane would cause the car carrier to hit the median designed for the south access that is intended to prohibit westbound left turns out of the site.]
 - Utilize the entire access width. **Response:** A car carrier cannot use the entire access width of the proposed south access of the auto dealership since the median designed for this south access is required to prohibit the westbound left turns out of the site. The car carrier cannot ride over the median to enter the site.
- For right-turns exiting the site:
 - Initiate the turn from the right side of the access. **Response:** Appendix “G” illustrates for the south access an HSU vehicle exiting the right side of the access to the greatest extent possible without hitting the median in the center intended to prohibit westbound left turns out of the access. The north access illustrates a car carrier turning right which does turn from the right side.
 - Utilize up to 3 receiving vehicular travel lanes. **Response:** Should the auto dealership land use be selected as the preferred land use to go forward to site plan approval, this option will be considered.

Consider increasing the throat width of the proposed accesses to provide a better balance between required corner radii and access width. Consider the use of truck aprons to reduce the effective corner radius and turning speed for smaller managed vehicles (i.e., passenger cars). **Response:** The wider access width is clearly a question dependent upon the final land use to go forward for site plan approval. This option will be considered further at that time.

In addition to the pork chop island at Access 1, please add a shaped centre median at Access 1 to reinforce the left-out restriction (i.e., provide the same condition as the Esso Service Station access).

Response: Please see the two concepts from the comment below

Consider extending the raised median southward all the way to the median at Deakin Street. Conversely, comment on the merits of leaving a small opening in the median for Waterbend Lane.

Response: Please find attached two exhibits one which shows an extended median all the way to Deakin Street [01 POW – Extended Median], and the other which shows a small opening to provide southbound left turn access into Waterbend Lane. [02 POW – Partial Median]. We prefer the later given the very low traffic volumes generated by the residences along Waterbend Lane.

As previously noted, a Roadway Modification Approval (RMA) report will be required for the proposed modifications to Prince of Wales Drive. The RMA is not required at the zoning stage and may be delayed until site plan approval. **Understood** The RMA may be completed, and the detailed design prepared, prior to site plan approval. The implementation of the road works will be tied to site plan approval through conditions in the delegated authority report. **Understood**

Section 4.3 Boundary Street Design:

Clarify the boundary street design modifications proposed to achieve the pedestrian level of service and bicycle level of service targets. Note previous Transportation Engineering Services comments requiring that the displaced paved shoulder / pathway on the east side of Prince of Wales Drive be replaced with a sidewalk and cycle track per City of Ottawa standards. A multi-use pathway per the Prince of Wales Drive EA is no longer the recommended facility per Official Plan and Transportation Master Plan policy.

Show a site plan of the boundary street design with the required road widenings for Prince of Wales Drive Environmental Study Report.

Response: Boundary Street modifications have been clarified in section 4.3. At the time of site plan application once a final land use has been decided upon and access designs completed, it is understood that Transportation Engineering Services preference for a sidewalk and cycle track as per City of Ottawa Standards will be prepared, respected and a functional plan prepared illustrating this and the resulting required road widenings.

Traffic Engineering

45m storage for southbound left turn to site access should be reviewed to see if additional length is required. With existing and expected northbound queues/volumes it is possible that gaps in traffic during the peak periods may be difficult to find and relying on drivers letting people in is unlikely at a location in which drivers experience frustrating travel conditions due to overcapacity roadways. Having traffic spill out of the southbound left turn lane is not going to be acceptable from an operations or safety perspective at this location.

Response: The table below indicates the resulting storage length and delays associated with the requirements for the southbound left turn from Prince of Wales Drive into Access 1 for each of the

various land uses considered. There is no capacity issue and the 45m provision provides more than sufficient storage space to accommodate forecast demands of each of the land uses being considered.

Southbound Left Turn Queue into Access 1 (meters)

	Morning Peak Hour	Afternoon Peak Hour
Auto Dealership (Table 4-6)	17m, (Delay 48 sec)	5m, Delay (21 sec)
400 Room Hotel (Table 4-7)	16m, (Delay 47 sec)	9m, Delay (23 sec)
80,000 SF Office (Table 4-8)	17m, (Delay 48 sec)	1m, Delay (18 sec)
70,000 SF Retail (Table 4-9)	10m, (Delay 39 sec)	16m, Delay (28 sec)

Explore opportunities to extend the available northbound left turn storage at the Hunt Club Road and Prince of Wales Drive intersection. With increase in volumes as part of this development, it is expected that northbound left turn queues will become an issue in which the existing storage may not be appropriate.

Response: At the time of site plan application these opportunities will be explored. Please appreciate that this is only for zoning approval to explore opportunities for alternative land uses, not to obtain site plan approval at this time. A narrower median for the northbound approach could potentially provide for double NB left turn lane which should also be explored.

Synchro Comments:

Modelling had issues with lane utilization in the models which lead to improper traffic flows. Please review and resubmit.

Certain traffic models (ex: 2031 Auto dealership AM) could not open Simtraffic please confirm all models are able to be opened and resubmit.

Response: As requested, new Simtraffic files have been provided and are attached as a zipped file. ✓

Road Safety

Access 1 (Southerly Site Access):

1. Prohibit U-turns on the northbound approach. **Response:** A note has been placed on drawing in Appendix "D" Proposed Access Concept indicating that northbound U-turns are prohibited at Access No. 1. Appendix "D" has been revised (Pls see attached) to include the northbound "U" turn prohibition. This replacement page [POW – Revised Appendix D.pdf] has been inserted in the revised document.

Guardrail:

2. Guardrail on the east side of Prince of Wales Road should be maintained and/or provided in accordance with MTO Roadside Design Manual (2020). **Response:** Agreed! A note has been placed on drawing in Appendix "D" Proposed Access Concept assuring that modifications to the guardrail are in accordance with MTO Roadside Design Manual (2020).

This replacement page [POW – Revised Appendix D.pdf] has been inserted in Appendix “D” in the revised document.