

- LEGEND**
- PROPERTY LINE
  - ▲ PROPOSED BUILDING ENTRANCE
  - ▨ TERRACING 3:1 SLOPE MAX (UNLESS OTHERWISE INDICATED)
  - PROPOSED CURB
  - DC PROPOSED DEPRESSED CURB
  - ⌒ PROPOSED CAP
  - PROPOSED STORM SEWER AND MANHOLE
  - LIGHT DUTY SILT FENCE (OPSD 219.110)
  - PROPOSED FILTER BAGS AT CATCHBASINS, AREA DRAINS AND TRENCHDRAINS
  - ▤ PROPOSED AREA DRAIN
  - MM PROPOSED MUD MAT
  - STM MH EXISTING STORM MANHOLE
  - CB EXISTING CATCHBASIN
  - ⊙ LS EXISTING LIGHT STANDARD
  - X EXISTING FENCE
  - ▲ EXISTING ROAD SIGNAGE

- NOTES**
- EROSION AND SEDIMENT CONTROL NOTES:**
- THE CONTRACTOR SHALL IMPLEMENT BEST MANAGEMENT PRACTICES, TO PROVIDE FOR PROTECTION OF THE AREA DRAINAGE SYSTEM AND THE RECEIVING WATERCOURSE, DURING CONSTRUCTION ACTIVITIES. THE CONTRACTOR ACKNOWLEDGES THAT FAILURE TO IMPLEMENT APPROPRIATE EROSION AND SEDIMENT CONTROL MEASURES MAY BE SUBJECT TO PENALTIES IMPOSED BY ANY APPLICABLE REGULATORY AGENCY.
- THE OWNER AGREES TO PREPARE AND IMPLEMENT AN EROSION AND SEDIMENT CONTROL PLAN TO THE SATISFACTION OF THE CITY OF OTTAWA, APPROPRIATE TO THE SITE CONDITIONS, PRIOR TO UNDERTAKING ANY SITE ALTERATIONS (FILLING, GRADING, REMOVAL OF VEGETATION, ETC.) AND DURING ALL PHASES OF SITE PREPARATION AND CONSTRUCTION IN ACCORDANCE WITH THE CURRENT BEST MANAGEMENT PRACTICES FOR EROSION AND SEDIMENT CONTROL SUCH AS BUT NOT LIMITED TO INSTALLING FILTER CLOTHS ACROSS MANHOLE/CATCHBASIN LIDS TO PREVENT SEDIMENTS FROM ENTERING STRUCTURES AND INSTALL AND MAINTAIN A LIGHT DUTY SILT FENCE BARRIER AS REQUIRED.
  - THE CONTRACTOR SHALL PLACE FILTER BAGS UNDER THE CATCHBASIN AND MANHOLE GRATES FOR THE DURATION OF CONSTRUCTION AND WILL REMAIN IN PLACE DURING ALL PHASES OF CONSTRUCTION.
  - SILT FENCING FOR ENTIRE PERIMETER OF SITE, SHALL BE UTILIZED TO CONTROL EROSION FROM THE SITE DURING CONSTRUCTION.
  - THE CONTRACTOR ACKNOWLEDGES THAT FAILURE TO IMPLEMENT EROSION AND SEDIMENT CONTROL MEASURES MAY BE SUBJECT TO PENALTIES IMPOSED BY ANY APPLICABLE REGULATORY AGENCY.
  - PROVIDE MUD MATS AT ALL CONSTRUCTION ACCESS POINTS TO MINIMIZE SEDIMENT TRANSPORT OFFSITE.
  - EROSION AND SEDIMENT CONTROL MEASURES MAY BE MODIFIED IN THE FIELD AT THE DISCRETION OF THE CITY OF OTTAWA SITE INSPECTOR OR CONSERVATION AUTHORITY.

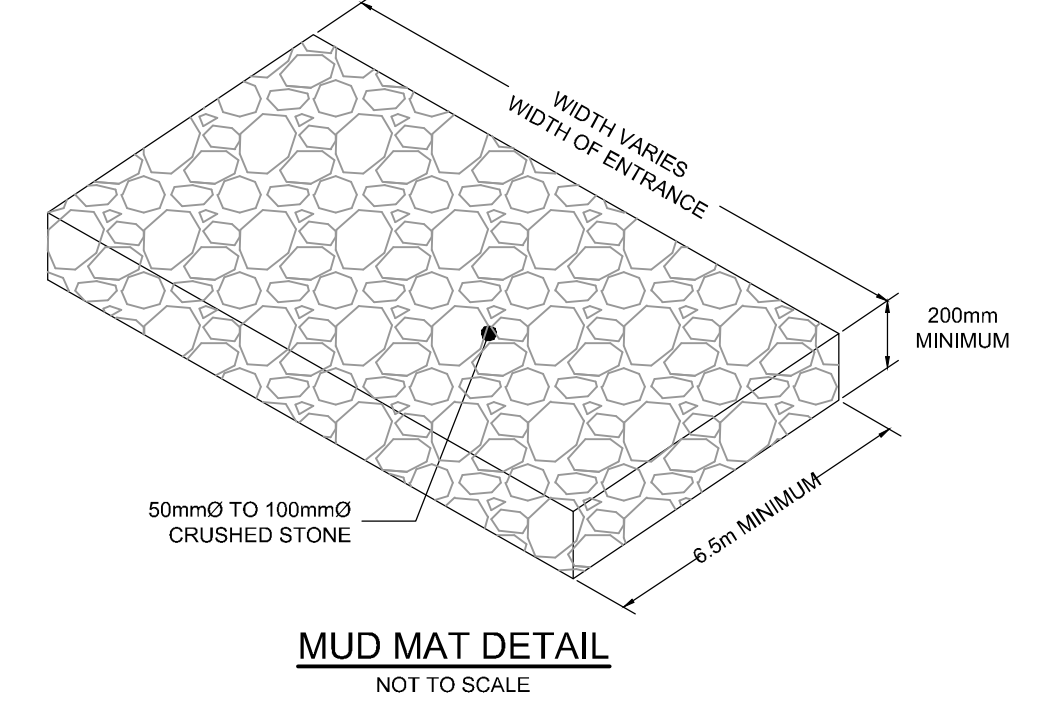
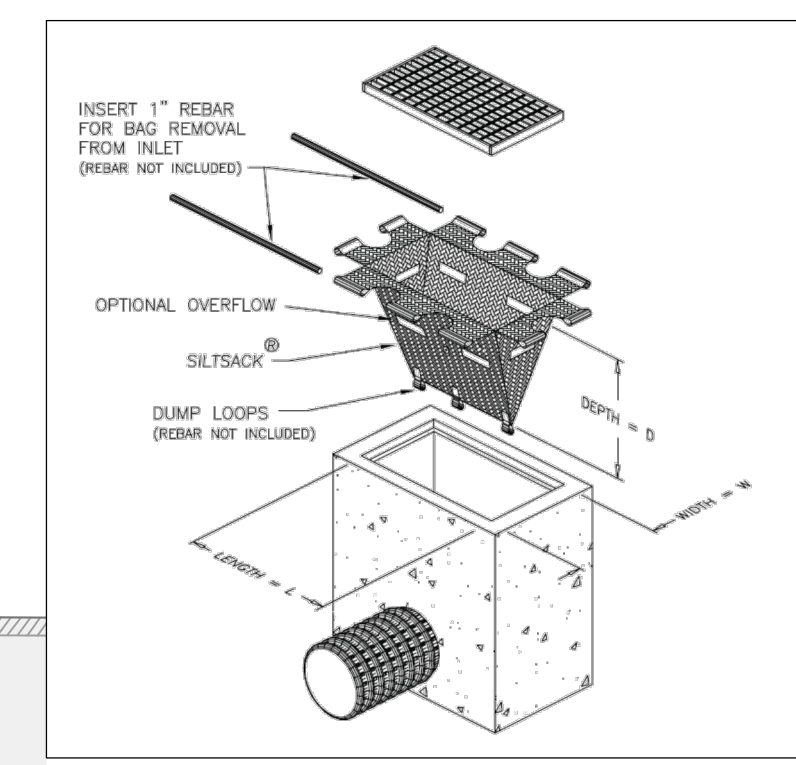

**NOTE:**  
THE POSITION OF ALL POLE LINES, CONDUITS, WATERMANS, SEWERS AND OTHER UNDERGROUND AND OVERGROUND UTILITIES AND STRUCTURES IS NOT NECESSARILY SHOWN ON THE CONTRACT DRAWINGS, AND WHERE SHOWN, THE ACCURACY OF THE POSITION OF SUCH UTILITIES AND STRUCTURES IS NOT GUARANTEED. BEFORE STARTING WORK, DETERMINE THE EXACT LOCATION OF ALL SUCH UTILITIES AND STRUCTURES AND ASSUME ALL LIABILITY FOR DAMAGE TO THEM.

**CLARIDGE HOMES**  
505 PRESTON STREET,  
OTTAWA, ONTARIO  
K1S 4N7.

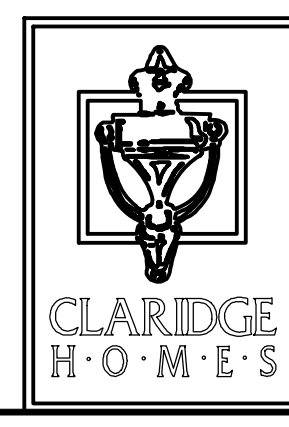

No.	REVISION	DATE	BY
2.	REVISED PER CITY COMMENTS	FEB 09/24	GJM
1.	ISSUED FOR CLIENT REVIEW	AUG 09/23	GJM

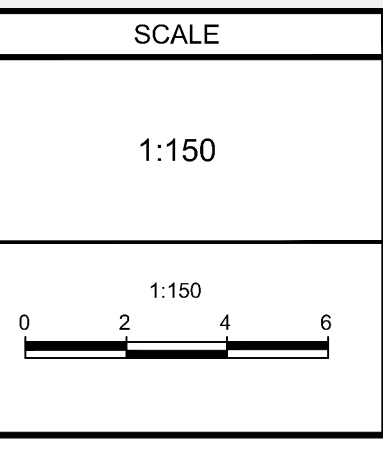

DESIGN	RJG
CHECKED	GJM
DRAWN	RJG/MF
CHECKED	ARM
APPROVED	GJM



**NOVATECH**  
Engineers, Planners & Landscape Architects  
Suite 200, 240 Michael Cowpland Drive  
Ottawa, Ontario, Canada K2M 1P6

Telephone (613) 254-9643  
Facsimile (613) 254-5867  
Website www.novatech-eng.com

LOCATION CITY OF OTTAWA 84 & 100 GLOUCESTER STREET	PROJECT No. 122173-00
DRAWING NAME GRADING AND EROSION - SEDIMENT CONTROL PLAN	REV # 2 REV # 2
	DRAWING No. 122173-ESC

M:\2023\122173\NOVATECH\122173-ESC.dwg, ESC, Aug 09, 2023 - 10:01 am, ipod

PLAN # 189444 002-02-23-0013 & 007-12-23-0021