

# 315, 321 Chapel Street Transportation Impact Assessment

Step 1 Screening Report

Step 2 Scoping Report (Revision #3)

Prepared for:

Windmill Developments Group Ltd.  
300 Richmond Road, Suite 400  
Ottawa, Ontario K1Z 6X6

Prepared by:



6 Plaza Court  
Ottawa, ON K2H 7W1

February 2024

PN: 2023-022

## Table of Contents

1	Screening .....	1
2	Existing and Planned Conditions .....	1
2.1	Proposed Development.....	1
2.2	Existing Conditions .....	3
2.2.1	Area Road Network .....	3
2.2.2	Existing Intersections.....	3
2.2.3	Existing Driveways .....	4
2.2.4	Cycling and Pedestrian Facilities.....	4
2.2.5	Existing Transit.....	7
2.2.6	Existing Area Traffic Management Measures.....	8
2.2.7	Existing Peak Hour Travel Demand.....	8
2.2.8	Collision Analysis .....	10
2.3	Planned Conditions.....	12
2.3.1	Changes to the Area Transportation Network .....	12
2.3.2	Other Study Area Developments.....	12
3	Study Area and Time Periods .....	12
3.1	Study Area .....	12
3.2	Time Periods .....	12
3.3	Horizon Years.....	13
4	Exemption Review .....	13
5	Development Design .....	13
5.1	Design for Sustainable Modes .....	13
5.2	Circulation and Access .....	14
6	Parking.....	14
6.1	Parking Supply .....	14
7	Boundary Street Design.....	14
8	Access Intersections Design .....	15
8.1	Location and Design of Access.....	15
8.2	Intersection Control.....	15
8.3	Access Intersection Design .....	15
8.3.1	Access Intersection MMLOS .....	15
8.3.2	Recommended Design Elements.....	15
9	Transportation Demand Management .....	15
9.1	Context for TDM .....	15
9.2	Need and Opportunity.....	15
9.3	TDM Program .....	15
10	Summary of Improvements Indicated and Modifications Options.....	16
11	Conclusion .....	18

## List of Figures

Figure 1:	Area Context Plan .....	1
-----------	-------------------------	---

Figure 2: Concept Plan..... 2  
 Figure 3: Area Driveways..... 4  
 Figure 4: Study Area Pedestrian Facilities ..... 5  
 Figure 5: Study Area Cycling Facilities ..... 5  
 Figure 6: Existing Pedestrian Volumes ..... 6  
 Figure 7: Existing Cyclist Volumes ..... 7  
 Figure 8: Existing Study Area Transit Service..... 8  
 Figure 9: Existing Study Area Transit Stops ..... 8  
 Figure 10: Existing Traffic Counts ..... 9  
 Figure 11: Study Area Collision Records..... 11

### Table of Tables

Table 1: Intersection Count Dates ..... 9  
 Table 2: Existing Intersection Operations..... 10  
 Table 3: Study Area Collision Summary, 2016-2020 ..... 10  
 Table 4: Summary of Collision Locations, 2016-2020 ..... 11  
 Table 5: Exemption Review ..... 13  
 Table 6: Additional TIA Exemptions..... 13  
 Table 7: Boundary Street MMLOS Analysis..... 14

### List of Appendices

- Appendix A – TIA Screening Form and Certification Form
- Appendix B – Turning Movement Count Data
- Appendix C – Synchro Intersection Worksheets – Existing Conditions
- Appendix D – Collision Data
- Appendix E – TDM Checklist
- Appendix F – Blackburn Avenue Signage Plan
- Appendix G – MMLOS Analysis

## 1 Screening

This study has been prepared according to the City of Ottawa’s 2017 Transportation Impact Assessment (TIA) Guidelines, prior to the June 2023 updates. Accordingly, a Step 1 Screening Form has been prepared and is included as Appendix A, along with the Certification Form for the TIA Study PM. As shown in the Screening Form, a TIA is not required. This scoped study has been prepared at the request of the City to support a zoning amendment and site plan application.

## 2 Existing and Planned Conditions

### 2.1 Proposed Development

The existing site, forming parts of 315 and 321 Chapel Street, is zoned as a Residential Fifth Density Zone (R5B 2452) and includes an existing courtyard and the former Bate Hall building. The site proposes the redevelopment of the east side of these parcels into a nine-storey residential building with 113 units, and no changes in land use to the former church building west of the site whose façade will be integrated into the new building. A new two-way, full-movement access is proposed on Blackburn Avenue at the south end of the site. Fifty-four vehicle parking spaces are proposed within two underground parking levels, along with 136 bike parking spaces on the ground floor. The anticipated build-out and occupancy horizon is 2025. Figure 1 illustrates the study area context. Figure 2 illustrates the proposed concept plan.

Figure 1: Area Context Plan

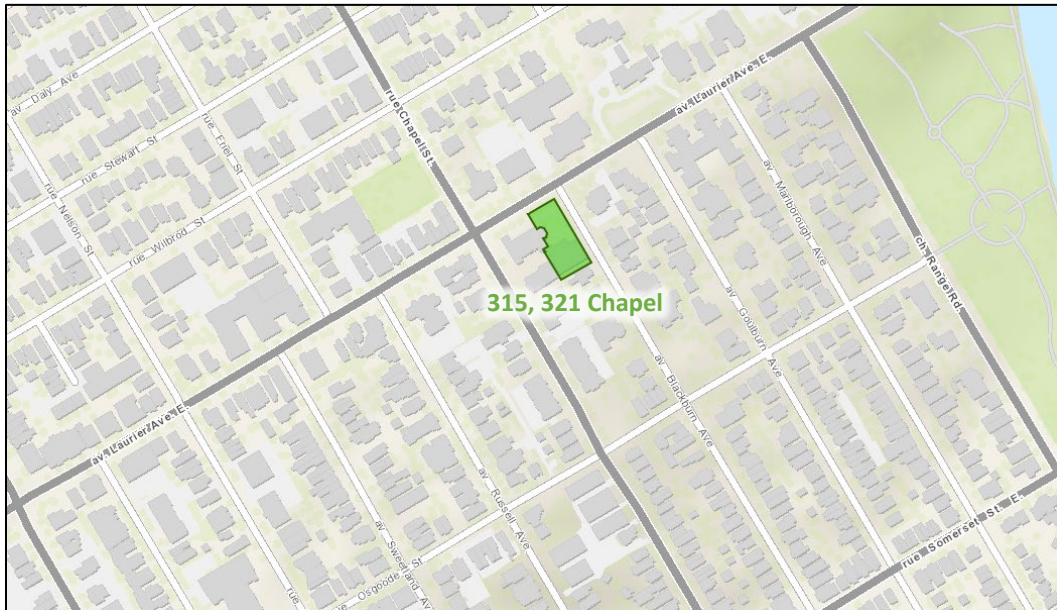

Source: <http://maps.ottawa.ca/geoOttawa/> Accessed: February 2, 2024



## 2.2 Existing Conditions

### 2.2.1 Area Road Network

*Laurier Avenue East:* Laurier Avenue East is a City of Ottawa major collector road with a two-lane urban cross-section with sidewalks on both sides of the road. Framed parking is provided on both sides of the road throughout the study area. The unposted speed limit is assumed to be 50 km/h and the measured right-of-way is 20.0 metres.

*Chapel Street:* Chapel Street is a City of Ottawa collector road with a two-lane urban cross-section with sidewalks on both sides of the road. On-street parking is permitted on the west side of the road. North of Laurier Avenue East, the unposted speed limit is assumed to be 50 km/h, and south of Laurier Avenue East, the posted speed limit is 30 km/h. The measured right-of-way is 20.0 metres in the study area. Through the signalized intersection with Laurier Avenue East, the unposted speed limit is 50 km/h.

*Blackburn Avenue:* Blackburn Avenue is a City of Ottawa local road with a two-lane urban cross-section with sidewalks on both sides of the road. On-street parking is permitted on the west side of the road. The posted speed limit is 30 km/h, and the measured right-of-way is 18.5 metres.

*Sweetland Avenue:* Sweetland Avenue is a City of Ottawa local road with a two-lane urban cross-section with sidewalks on both sides of the road. On-street parking is permitted on the east side of the road. The posted speed limit is 30 km/h, and the measured right-of-way is 18.5 metres. Through the signalized intersection with Laurier Avenue East, the unposted speed limit is 50 km/h.

*Nelson Street:* Nelson Street is a City of Ottawa local road with a two-lane urban cross-section with sidewalks on both sides of the road. On-street parking is permitted on the west side of the road, outside of a section for 100 metres south of Laurier Avenue East where it is permitted on the east side. The posted speed limit is 30 km/h, and the measured right-of-way is 18.5 metres. Through the signalized intersection with Laurier Avenue East, the unposted speed limit is 50 km/h.

*Osgoode Street:* Osgoode Street is a City of Ottawa local road with a two-lane urban cross-section with sidewalks on both sides of the road. On-street parking switches every one-to-two blocks between the north and south sides of the road along the length of Osgoode Street. The posted speed limit is 30 km/h, and the measured right-of-way is 20.0 metres.

### 2.2.2 Existing Intersections

The existing signalized area intersections and key unsignalized intersections for site access within 400 metres of the site have been summarized below:

*Laurier Avenue at Nelson Street*

The intersection of Laurier Avenue at Nelson Street is a signalized intersection. All approaches consist of a shared all-movements lane. No turn restrictions were noted.

*Laurier Avenue at Sweetland Avenue*

The intersection of Laurier Avenue at Sweetland Avenue is a signalized T-intersection. The northbound approach consists of a shared left-turn/right-turn lane. The eastbound approach consists of a shared through/right-turn lane and the westbound approach consists of a shared left-turn/through lane. No turn restrictions were noted.

*Laurier Avenue at Chapel Street*

The intersection of Laurier Avenue at Chapel Street is a signalized intersection. All approaches consist of a shared all-movements lane. No turn restrictions were noted.

*Laurier Avenue at Blackburn Avenue*

The intersection of Laurier Avenue at Blackburn Avenue is an unsignalized intersection with stop control on the minor approaches of Blackburn Avenue/the private southbound approach. All approaches consist of a shared all-movements lane. No turn restrictions were noted.

*Osgoode Street at Blackburn Avenue*

The intersection of Osgoode Street at Blackburn Avenue is an unsignalized intersection with stop control on the minor approaches of Blackburn Avenue. All approaches consist of a shared all-movements lane. No turn restrictions were noted.

2.2.3 Existing Driveways

Within 200 metres of the proposed site access, 15 driveways are on Blackburn to private residences, to embassies, to a commercial building, and to an early learning centre. On Laurier Avenue East, one rear lane to various land uses is present and 11 driveways are present to low-rise residential land uses, high-rise residential land uses, a commercial building, and an embassy. No changes or use of the existing access onto Chapel Street is proposed for the existing land uses on the west side of the property. The existing area driveways are illustrated in Figure 3.

Figure 3: Area Driveways



Source: <http://maps.ottawa.ca/geoOttawa/> Accessed: February 2, 2024

2.2.4 Cycling and Pedestrian Facilities

Figure 4 illustrates the pedestrian facilities in the study area and Figure 5 illustrates the cycling facilities.

Sidewalks are provided on both sides along all study area roads. Cycling facilities include unidirectional bike lanes along each Stewart Street and Wilbrod Street, and bike lanes along Somerset Street East. Stewart Street, Wilbrod Street, and Somerset Street East are cross-town bikeways, Chapel Street and Laurier Avenue East/Charlotte Street are local routes.

Figure 4: Study Area Pedestrian Facilities

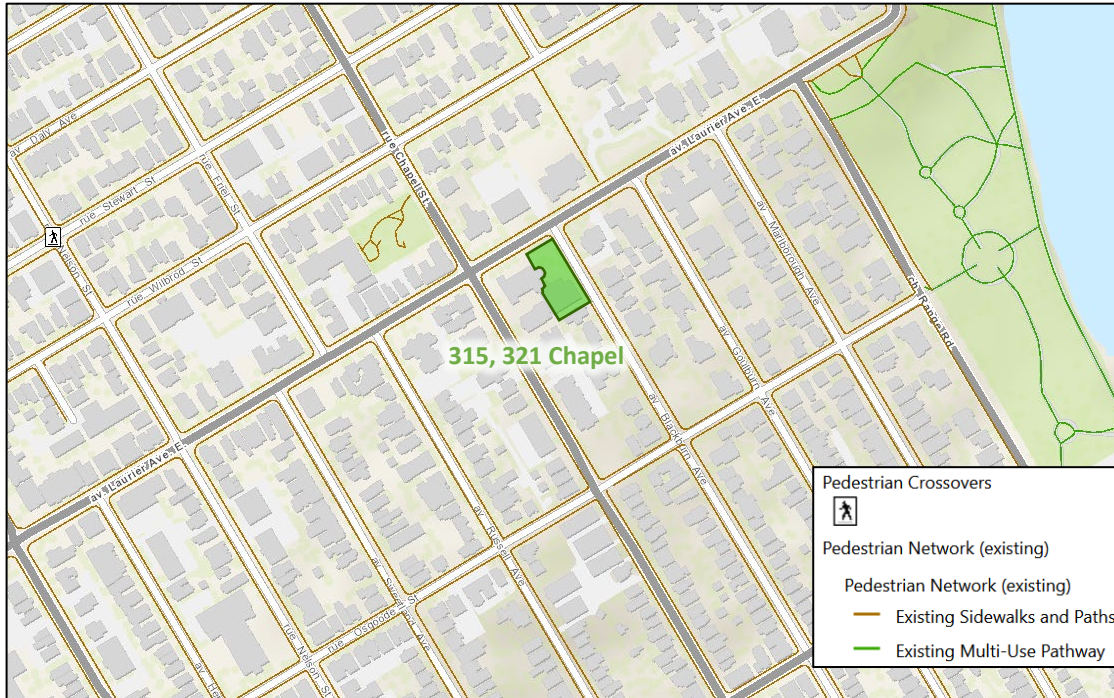

Source: <http://maps.ottawa.ca/geoOttawa/> Accessed: March 14, 2023

Figure 5: Study Area Cycling Facilities



Source: <http://maps.ottawa.ca/geoOttawa/> Accessed: March 14, 2023



Pedestrian and cyclist volumes included in study area intersection counts, presented in Section 2.2.7, have been compiled and are illustrated in Figure 6 and Figure 7, respectively. The intersection counts of Laurier Avenue at Nelson Street, at Sweetland Avenue, and at Chapel Street were conducted in the winter and may have recorded a lower number of cyclists than might be present during warmer months.

Figure 6: Existing Pedestrian Volumes

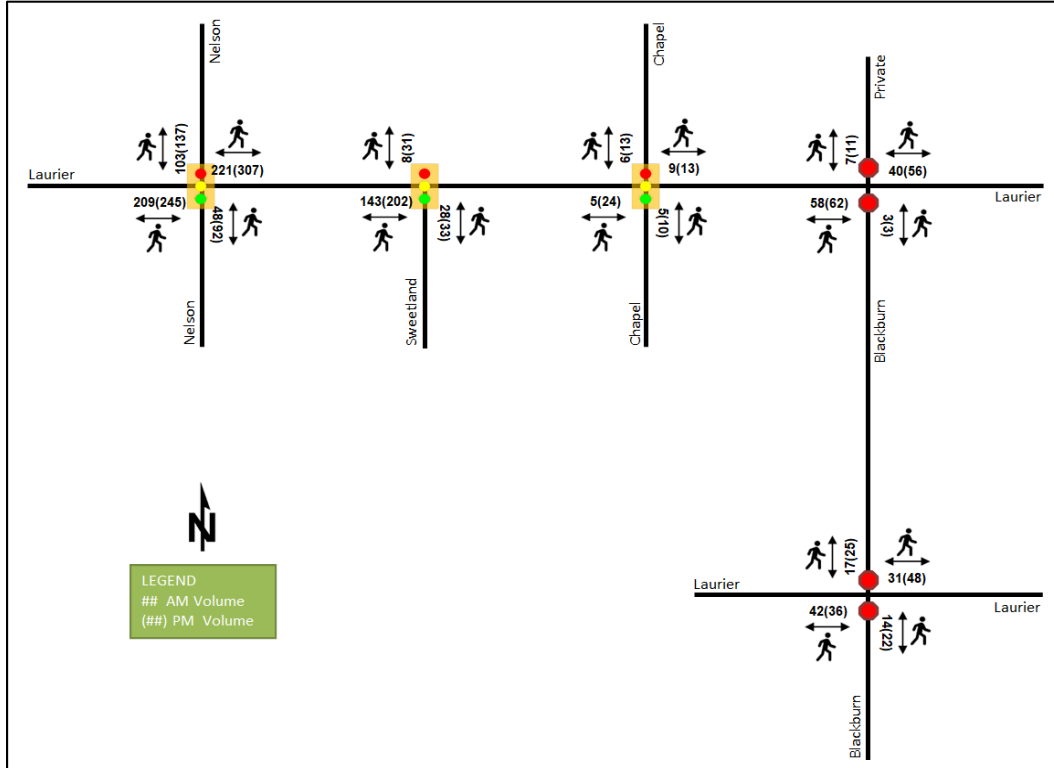
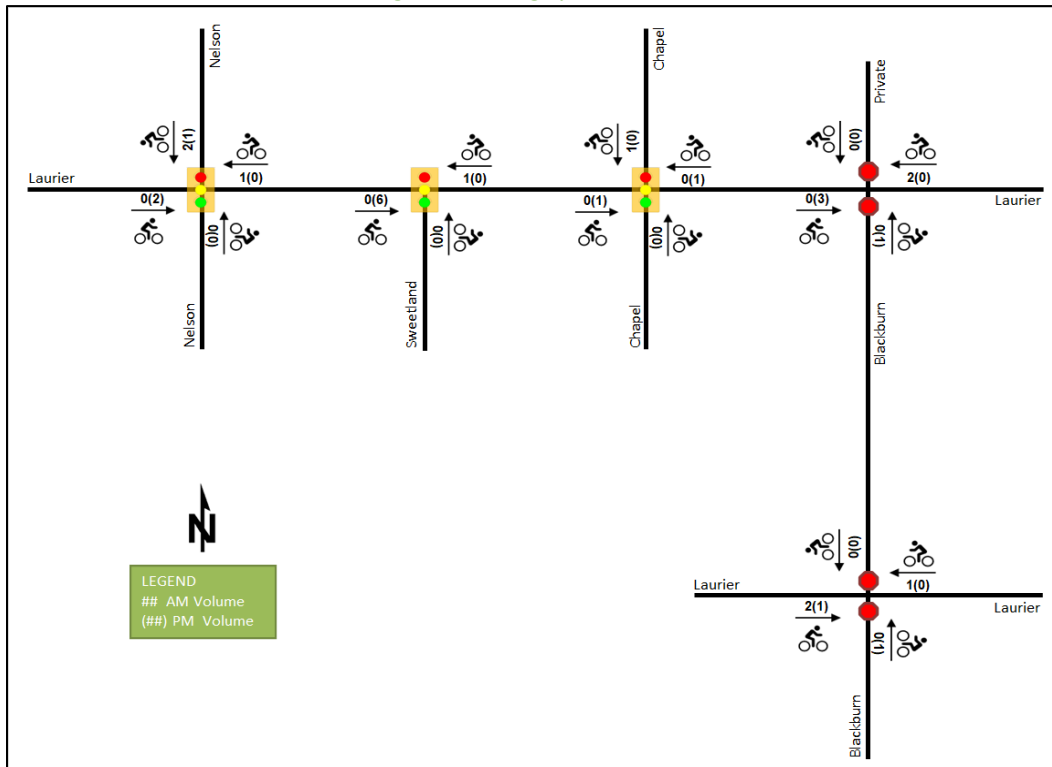

Figure 7: Existing Cyclist Volumes



### 2.2.5 Existing Transit

Figure 8 illustrates the transit system map in the study area and Figure 9 illustrates nearby transit stops. All transit information is from February 22, 2023 and is included for general information purposes and context to the surrounding area.

Within the study area, the route #19 travels along Laurier Avenue East and the route # 16 travels along Somerset Street East. The frequency of these routes within proximity of the proposed site based on February 22, 2023 service levels are:

- Route # 16 – 30-minute service all day
- Route # 19 – 30-minute service all day

Additionally, transit stops on the Rideau Street transit priority corridor are approximately 500m from the site, and provide access to frequent routes #7, #12, and #14, as well as local routes #15 and #18.

Figure 8: Existing Study Area Transit Service

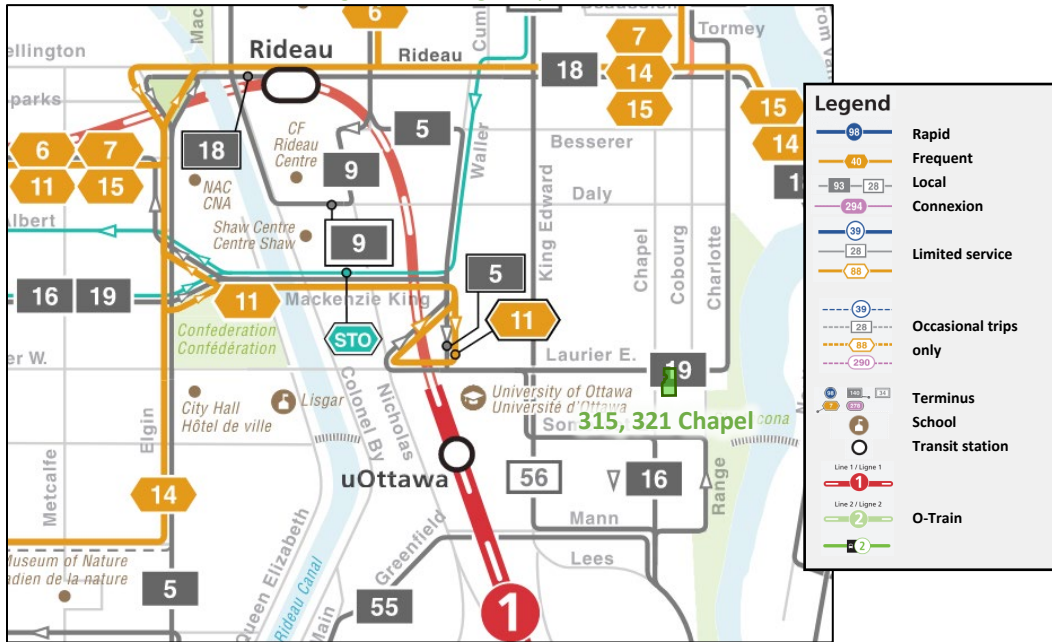

Source: <http://www.octranspo.com/> Accessed: February 22, 2023

Figure 9: Existing Study Area Transit Stops



Source: <http://www.octranspo.com/> Accessed: February 22, 2023

### 2.2.6 Existing Area Traffic Management Measures

Within the study area, bulb-outs and reduced corner radii are present at most intersections and textured crossings are provided at signalized intersections. On-street parking is present along study area local roads, and centreline flexible stake bollards and framed parking is provided on Laurier Avenue East.

### 2.2.7 Existing Peak Hour Travel Demand

Existing turning movement counts were acquired from the City of Ottawa and The Traffic Specialist for the existing study area intersections. Table 1 summarizes the intersection count dates and sources.

Table 1: Intersection Count Dates

Intersection	Count Date	Source
Laurier Avenue at Nelson Street	Wednesday, January 9, 2019	City of Ottawa
Laurier Avenue at Sweetland Avenue	Wednesday, January 9, 2019	City of Ottawa
Laurier Avenue at Chapel Street	Tuesday, January 11, 2022	City of Ottawa
Laurier Avenue at Blackburn Avenue	Tuesday, March 7, 2023	The Traffic Specialist
Osgoode Street at Blackburn Avenue	Tuesday, March 7, 2023	The Traffic Specialist

Figure 10 illustrates the existing traffic counts, balanced along Laurier Avenue East, and Table 2 summarizes the existing intersection operations. The level of service for signalized intersections is based on volume to capacity ratio (v/c) calculations for individual lane movements and HCM 2000 v/c calculations for the overall intersection, and average delay for unsignalized intersections. Detailed turning movement count data is included in Appendix B and the Synchro worksheets are provided in Appendix C.

Figure 10: Existing Traffic Counts

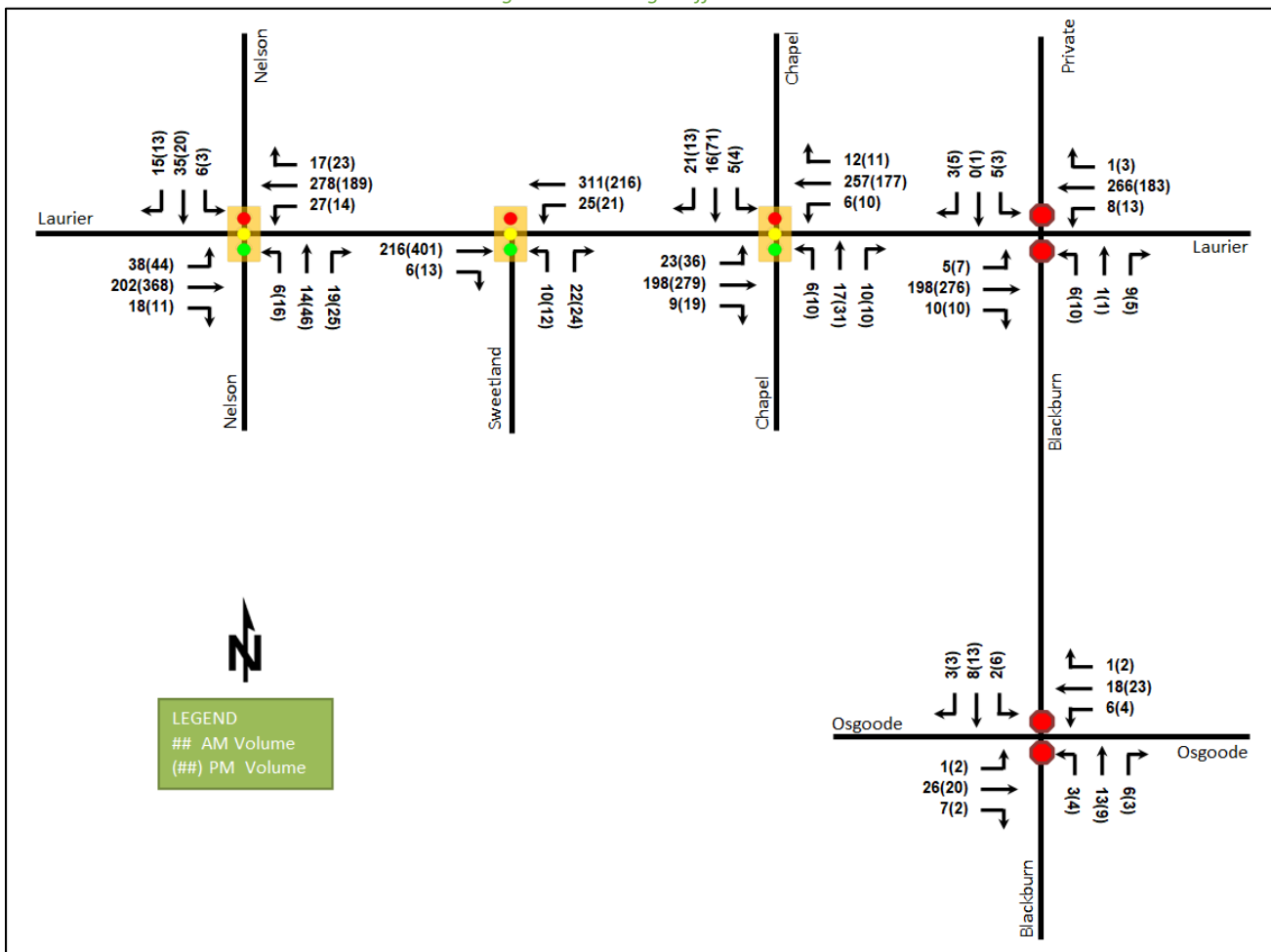

Table 2: Existing Intersection Operations

Intersection	Lane	AM Peak Hour				PM Peak Hour			
		LOS	V/C	Delay (s)	Q (95 <sup>th</sup> )	LOS	V/C	Delay (s)	Q (95 <sup>th</sup> )
Laurier Ave E at Nelson St <i>Signalized</i>	EB	A	0.32	6.9	25.7	A	0.47	8.8	48.5
	WB	A	0.37	3.7	3.2	A	0.26	4.4	9.4
	NB	A	0.13	15.3	9.7	A	0.30	21.6	20.5
	SB	A	0.18	18.9	13.8	A	0.13	18.3	10.0
	<b>Overall</b>	<b>A</b>	<b>0.31</b>	<b>6.9</b>	-	<b>A</b>	<b>0.41</b>	<b>9.4</b>	-
Laurier Ave E at Sweetland Ave <i>Signalized</i>	EB	A	0.18	2.4	12.3	A	0.32	1.7	10.1
	WB	A	0.28	2.7	16.9	A	0.19	2.7	14.9
	NB	A	0.18	16.4	8.2	A	0.22	18.1	9.4
	<b>Overall</b>	<b>A</b>	<b>0.28</b>	<b>3.3</b>	-	<b>A</b>	<b>0.32</b>	<b>2.9</b>	-
Laurier Ave E at Chapel St <i>Signalized</i>	EB	A	0.28	6.6	16.3	A	0.38	5.0	12.2
	WB	A	0.32	8.9	31.9	A	0.22	7.4	22.0
	NB	A	0.08	15.1	8.6	A	0.13	18.9	13.1
	SB	A	0.11	12.6	9.2	A	0.22	20.7	20.6
	<b>Overall</b>	<b>A</b>	<b>0.24</b>	<b>8.6</b>	-	<b>A</b>	<b>0.32</b>	<b>8.8</b>	-
Laurier Ave E at Blackburn Ave <i>Unsignalized</i>	EB	A	0.01	8.1	0.0	A	0.01	7.9	0.0
	WB	A	0.01	8.0	0.0	A	0.01	8.3	0.0
	NB	B	0.04	12.5	0.8	B	0.04	14.2	0.8
	SB	B	0.02	13.0	0.8	B	0.02	12.4	0.8
	<b>Overall</b>	<b>A</b>	-	<b>0.8</b>	-	<b>A</b>	-	<b>1.0</b>	-
Osgoode St at Blackburn Ave <i>Unsignalized</i>	EB	A	0.00	7.4	0.0	A	0.00	7.5	0.0
	WB	A	0.01	7.5	0.0	A	0.00	7.4	0.0
	NB	A	0.03	9.9	0.8	A	0.02	9.9	0.8
	SB	A	0.02	9.8	0.8	B	0.03	10.1	0.8
	<b>Overall</b>	<b>A</b>	-	<b>4.2</b>	-	<b>A</b>	-	<b>4.7</b>	-

Notes: Saturation flow rate of 1800 veh/h/lane  
Queue is measured in metres  
Peak Hour Factor = 0.90

Delay = average vehicle delay in seconds  
m = metered queue  
# = volume for the 95th %ile cycle exceeds capacity

During both the AM and PM peak hours, the study area intersections operate well. No capacity issues are noted.

2.2.8 Collision Analysis

Collision data have been acquired from the City of Ottawa open data website (data.ottawa.ca) for five years prior to the commencement of this TIA for the surrounding study area road network. Table 3 summarizes the collision types and conditions in the study area, Figure 11 illustrates the intersections and segments analyzed, and Table 4 summarizes the total collisions for each of these locations. Collision data are included in Appendix D.

Table 3: Study Area Collision Summary, 2016-2020

Total Collisions		Number	%
Total Collisions		29	100%
Classification	Fatality	0	0%
	Non-Fatal Injury	2	7%
	Property Damage Only	27	93%
Initial Impact Type	Approaching	1	3%
	Angle	16	55%
	Rear end	4	14%
	Sideswipe	1	3%
	Turning Movement	2	7%
	SMV Unattended	2	7%
	SMV Other	3	10%

		Number	%
<b>Total Collisions</b>		29	<b>100%</b>
<b>Road Surface Condition</b>	Dry	15	52%
	Wet	4	14%
	Loose Snow	4	14%
	Slush	2	7%
	Packed Snow	3	10%
	Ice	1	3%
<b>Pedestrian Involved</b>		0	0%
<b>Cyclists Involved</b>		0	0%

Figure 11: Study Area Collision Records



Table 4: Summary of Collision Locations, 2016-2020

Intersections / Segments	Number	%
	<b>29</b>	<b>100%</b>
<b>Russell Ave @ Laurier Ave</b>	8	28%
<b>Chapel St @ Laurier Ave</b>	6	21%
<b>Laurier Ave E btwn Russell Ave &amp; Chapel St</b>	5	17%
<b>Blackburn Ave @ Laurier Ave</b>	3	10%
<b>Blackburn Ave @ Osgoode St</b>	3	10%
<b>Goulburn Ave @ Laurier Ave</b>	2	7%
<b>Blackburn Ave btwn Laurier Ave E &amp; Osgoode St</b>	1	3%
<b>Laurier Ave E btwn Chapel St &amp; Blackburn Ave</b>	1	3%

Within the study area, no locations are noted to have experienced a high incidence of collisions. Examining the collisions at the Russell Avenue at Laurier Avenue East intersection, it is noted that seven of eight collisions were angle collisions. None of these collisions occurred in 2020, when the no parking sign on the eastbound approach was relocated farther from the intersection by approximately one car length, thereby reducing visual obstruction between the eastbound and northbound approach.

No area mitigation is required, and no further review of collisions is required as part of this study.

## 2.3 Planned Conditions

### 2.3.1 Changes to the Area Transportation Network

The Byward Market to Somerset East neighbourhood bikeway project is included in the 2023 TMP Part 1. This project proposes the improvement of cycling connections between Byward Market and Somerset Street East, including an improved crossing of King Edward Avenue at York Street. The bikeway route through Sandy Hill is anticipated to utilize Chapel Street, though no measures have yet been identified for implementation. No timeline is available for implementation of the overall project.

### 2.3.2 Other Study Area Developments

#### *280 Laurier Avenue*

The proposed development application includes a zoning amendment and site plan application to permit the construction of a three-storey residential addition to an existing mid-rise building. No TIA was required for this development.

#### *29 Russell Avenue*

The proposed development application includes a zoning amendment and site plan application to permit the construction of a new low-rise, three-storey residential addition to the original, retained building. The addition will provide a total of 21 units including 14 in the existing building, and 7 in the new building. No TIA was required for this application.

#### *326-330 Wilbrod Street*

The proposed development application includes a zoning amendment to decrease setbacks, landscaping, and minimum required parking spaces for a four-storey apartment building. No TIA was required for this application.

#### *68 Sweetland Avenue, 146 Osgoode Street*

The proposed development application includes a zoning amendment and site plan application to permit an addition to an existing residential building. No TIA was required for this application.

## 3 Study Area and Time Periods

### 3.1 Study Area

The study area will include the intersections of:

- Laurier Avenue East at:
  - Nelson Street
  - Sweetland Avenue
  - Chapel Street
  - Blackburn Avenue
- Osgoode Street at:
  - Blackburn Avenue

The boundary roads will be Blackburn Avenue and Laurier Avenue East, and no screenlines are present within the study area.

### 3.2 Time Periods

As the proposed development is a mixed-use development composed of residential units, the weekday AM and PM peak hours will be examined.

### 3.3 Horizon Years

The anticipated build-out year is 2025. As a result, the full build-out plus five years horizon year is 2030.

## 4 Exemption Review

Table 5 summarizes the exemptions for this TIA.

*Table 5: Exemption Review*

Module	Element	Explanation	Exempt/Required
<b>Design Review Component</b>			
<b>4.1 Development Design</b>	4.1.2 Circulation and Access	Only required for site plans	Required
	4.1.3 New Street Networks	Only required for plans of subdivision	Exempt
<b>4.2 Parking</b>	4.2.1 Parking Supply	Only required for site plans	Required
	4.2.2 Spillover Parking	Only required for site plans where parking supply is 15% below unconstrained demand	Exempt
<b>Network Impact Component</b>			
<b>4.5 Transportation Demand Management</b>	All Elements	Not required for site plans expected to have fewer than 60 employees and/or students on location at any given time	Required
<b>4.6 Neighbourhood Traffic Management</b>	4.6.1 Adjacent Neighbourhoods	Only required when the development relies on local or collector streets for access and total volumes exceed ATM capacity thresholds	Exempt (based on scoping)
<b>4.8 Network Concept</b>		Only required when proposed development generates more than 200 person-trips during the peak hour in excess of equivalent volume permitted by established zoning	Exempt

The scoped TIA was required to contain all Step 2 sections with additional Step 4 modules. Table 6 summarizes the additional TIA module and element exemptions for the Step 3 and Step 4 sections requested for the site and confirmed, via email, by the City’s Transportation Project Manager on June 1, 2023.

*Table 6: Additional TIA Exemptions*

Module	Element
<b>3.1 Development Generated Travel Demand</b>	3.1.2 Trip Distribution
	3.1.3 Trip Assignment
<b>3.2 Background Network Travel Demand</b>	All Elements
<b>3.3 Demand Rationalization</b>	All Elements
<b>4.4 Access Intersections</b>	All Elements
<b>4.7 Transit</b>	All Elements
<b>4.9 Network Concept</b>	All Elements

## 5 Development Design

### 5.1 Design for Sustainable Modes

The proposed development is a residential development with underground vehicle parking and ground level bicycle parking. A total of 136 bike parking spaces will be provided including 121 internal spaces on the ground



floor and 15 external spaces. Existing sidewalks are provided along the boundary streets of Laurier Avenue East and Blackburn Avenue, and walkways are proposed to connect the site entrances to the sidewalks.

Stops for existing transit route #19 are within immediate proximity to the site and stops to the existing transit route #16 are within 500 metres’ walking distance of the site.

The infrastructure TDM checklist is provided in Appendix E.

### 5.2 Circulation and Access

A new two-way, full-movement access is provided on Blackburn Avenue at the south end of the site which provides vehicular access to the underground parking via a 6.0-metre-wide ramp.

Redesignation of parking as a loading/fifteen-minute parking area for an approximately 20-metre-long segment along the building entrance on Blackburn Avenue is proposed, for which a signage plan is provided in Appendix F. Emergency services may access the site via the Laurier Avenue and Blackburn Avenue frontages. Given the depth of the existing lot, a heavy single-unit truck would not have sufficient space circulate internally. Garbage collection will take place on Blackburn Avenue.

## 6 Parking

### 6.1 Parking Supply

The site provides 50 vehicle parking spaces for residents and four spaces for visitors within two underground parking levels, along with 136 bike parking spaces on the ground floor including 121 internal spaces and 15 external spaces. From the zoning by-law, the minimum vehicle parking provision for residents is 45 spaces as all parking is located below grade. The minimum visitor vehicle parking is ten spaces, and minimum bicycle parking is 56 spaces. The resident vehicle parking is proposed as being met, and the visitor vehicle parking is proposed as being six spaces below the zoning by-law requirements, and bicycle parking requirement is exceeded.

## 7 Boundary Street Design

Table 7 summarizes the MMLOS analysis for the boundary streets of Laurier Avenue East and Blackburn Avenue. Where the existing and future conditions for the streets will be the same, they are considered in one row. The boundary street analysis is based on the land-use of “General Urban Area”. The MMLOS worksheets has been provided in Appendix G.

Table 7: Boundary Street MMLOS Analysis

Segment		Pedestrian LOS		Bicycle LOS		Transit LOS		Truck LOS	
		PLOS	Target	BLOS	Target	TLOS	Target	TrLOS	Target
Laurier Avenue E	Ex./Fut.	C	C	F	B	-	-	-	-
Blackburn Avenue	Ex.	F	C	B	D	-	-	-	-
Blackburn Avenue	Fut.	E	C	B	D	-	-	-	-

Blackburn Avenue will not meet the pedestrian LOS targets, and Laurier Avenue East will not meet bicycle LOS targets.

To meet pedestrian LOS targets on Blackburn Avenue, a 0.5-metre-wide boulevard or widening of the sidewalk to 1.8 metres would be required. While 1.8 metres is the City target for sidewalk widths, the provision of this width is precluded by existing boulevard spacing, grading, stormwater, utilities, and street tree constraints on the frontage. The sidewalk will be widened from 1.2 metres to 1.5 metres, which will improve the PLOS and meet the AODA minimum width.

Bicycle LOS on Laurier Avenue East is limited by the mixed traffic conditions and operating speeds on Laurier Avenue East. Physically separated facilities would be required to meet the BLOS target, which are typically implemented on a corridor-wide basis. No cycling treatments are required to support the subject development, and any modifications to improve area BLOS are considered the responsibility of the City.

## 8 Access Intersections Design

### 8.1 Location and Design of Access

The development proposes a 6.3-metre-wide two-way full-movement access on Blackburn Avenue, 2.35 metres from the proposed southern property line. This access location would need approval through the site plan application process in line with provision 25(1)(r) from the private approach by-law. No safety issues are noted for the proposed access location which is approximately 12 metres away from the driveway on the adjacent property parcel.

### 8.2 Intersection Control

The site access will have stop-control on the minor approach.

### 8.3 Access Intersection Design

#### 8.3.1 Access Intersection MMLoS

The site access is unsignalized and accordingly does not require MMLoS review.

#### 8.3.2 Recommended Design Elements

An existing sidewalk is provided along the boundary street of Blackburn Avenue. The proposed access is recommended to be constructed in compliance with the City standard SC7.1 with a continuous sidewalk across the access tying into the roadway via a curb depression.

## 9 Transportation Demand Management

### 9.1 Context for TDM

The typical district modal shares are likely to be achieved and supporting TDM measures should be provided.

### 9.2 Need and Opportunity

Risks to other network users from failing to meet mode share targets are negligible given the low trip generation.

### 9.3 TDM Program

The “suite of post occupancy TDM measures” has been summarized in the TDM checklists for the residential land uses. The checklist is provided in Appendix E. The key TDM measures recommended include:

- Display local area maps with walking and cycling routes, and transit route information and schedules at major entrances
- Provide a multimodal travel option information package to new residents
- Contract with providers to install on-site bikeshare (or other micromobility alternatives) and carshare spaces
- Inclusion of a 1-month Presto card for first time new purchase, with a set time frame for this offer (e.g. 6-months) from the initial opening of the site
- Unbundle parking cost from rental costs

## 10 Summary of Improvements Indicated and Modifications Options

The following summarizes the analysis and results presented in this TIA report:

### Proposed Site and Screening

- The site proposes the redevelopment of the east side of the property parcels into a nine-storey residential building with 113 units
- No changes in land use to the former church building west of the site whose façade will be integrated into the new building
- A new two-way, full-movement access is proposed on Blackburn Avenue at the south end of the site
- The anticipated build-out and occupancy horizon is assumed to be 2025
- No triggers were met in a TIA Screening although a scoped TIA was requested by the City

### Existing Conditions

- Laurier Avenue East is a major collector road and Chapel Street is a collector road in the study area
- Sidewalks are provided on both sides along all study area roads
- Unidirectional bike lanes are provided along each Stewart Street and Wilbrod Street
- Bike lanes are provided along Somerset Street East
- Stewart Street, Wilbrod Street, and Somerset Street East are cross-town bikeways, and Chapel Street and Laurier Avenue East/Charlotte Street are local routes
- No locations are noted to have experienced a high incidence of collisions within the study area
- The study area intersections operate well during both the AM and PM peak hours at the existing condition

### Development Design

- The proposed development is a residential development with underground vehicle parking and ground level bicycle parking
- A total of 136 bike parking spaces will be provided including 121 internal spaces and 15 external spaces
- Existing sidewalks are provided along the boundary streets of Laurier Avenue East and Blackburn Avenue, and walkways are proposed to connect the site to the sidewalks
- Stops for existing transit route #19 are within immediate proximity to the site and stops to the existing transit route #16 are within 500 metres' walking distance of the site
- A new two-way, full-movement access is provided on Blackburn Avenue at the south end of the site
- Redesignation of parking as a loading/fifteen-minute parking area for an approximately 20-metre-long segment along the building entrance on Blackburn Avenue is proposed
- Emergency service may access the site via the boundary streets
- Garbage collection will take place on Blackburn Avenue

### Parking

- The site provides 50 resident vehicle parking spaces and four visitor vehicle parking spaces within two underground parking levels, along with 136 bike parking spaces
- The resident vehicle parking and bicycle parking provisions are proposed as meeting the zoning by-law requirements, visitor parking is below the by-law requirement by six spaces

### Boundary Street Design

- Blackburn Avenue will not meet pedestrian LOS targets, and while providing a 0.5-metre-wide or widening the sidewalk to 1.8 metres would meet the target, these treatments are precluded by grading, utility, and streetscaping constraints
- The proposed 1.5-metre-wide sidewalk is an increase in length from the existing 1.2-metre-wide sidewalk and meets the AODA minimum width
- Laurier Avenue East will not meet bicycle LOS targets due to mixed traffic conditions and operating speeds and meeting targets would require physically separated facilities which are considered the responsibility of the City to implement along the corridor

### Access Intersections Design

- The development proposed a full-movement access on Blackburn Avenue at the south end of the site
- The site access is a two-way access with a 6.3 metre width and connects to the underground garage
- The access offset from the adjacent property line of 2.35 metres will need to be approved through the site plan application
- The site access will have stop-control on the minor approach
- An existing sidewalk is provided along the boundary street of Blackburn Avenue, and the proposed site access will be constructed to comply with the City standard SC7.1

### TDM

- Supportive TDM measures to be included within the proposed development should include:
  - Display local area maps with walking and cycling routes, and transit route information and schedules at major entrances
  - Provide a multimodal travel option information package to new residents
  - Contract with providers to install on-site bikeshare (or other micromobility alternatives) and carshare spaces
  - Inclusion of a 1-month Presto card for first time new purchase, with a set time frame for this offer (e.g. 6-months) from the initial opening of the site
  - Unbundle parking cost from rental costs

## 11 Conclusion

It is recommended that, from a transportation perspective, the proposed development application proceed.

Prepared By:



John Kingsley, EIT  
Transportation Engineer Intern

Reviewed By:



Andrew Harte, P.Eng.  
Senior Transportation Engineer

# Appendix A

TIA Screening Form and PM Certification Form

City of Ottawa 2017 TIA Guidelines  
Step 1 - Screening Form

Date: 19-Jul-23  
Project Number: 2023-022  
Project Reference: 315 Chapel

1.1 Description of Proposed Development	
Municipal Address	315 Chapel Street
Description of Location	Ward 12. Southwest corner of intersection of Laurier Avenue East at Blackburn Avenue
Land Use Classification	Residential Fifth Density (R5B[2454]S379(-h))
Development Size	113 Apartment Units
Accesses	One new full-moves, two-way access on Blackburn Ave
Phase of Development	Single
Buildout Year	2025
TIA Requirement	No TIA Required

1.2 Trip Generation Trigger		
Land Use Type	Apartment Units	
Development Size	113	Units
Trip Generation Trigger	No	See attached trip generation

1.3 Location Triggers	
Does the development propose a new driveway to a boundary street that is designated as part of the City's Transit Priority, Rapid Transit or Spine Bicycle Networks?	No
Is the development in a Design Priority Area (DPA) or Transit-oriented Development (TOD) zone?	No
Location Trigger	No

1.4. Safety Triggers	
Are posted speed limits on a boundary street 80 km/hr or greater?	No
Are there any horizontal/vertical curvatures on a boundary street limits sight lines at a proposed driveway?	No
Is the proposed driveway within the area of influence of an adjacent traffic signal or roundabout (i.e. within 300 m of intersection in rural conditions, or within 150 m of intersection in urban/ suburban conditions)?	No
Is the proposed driveway within auxiliary lanes of an intersection?	No
Does the proposed driveway make use of an existing median break that serves an existing site?	No
Is there is a documented history of traffic operations or safety concerns on the boundary streets within 500 m of the development?	No
Does the development include a drive-thru facility?	No
Safety Trigger	No

*Table 1: Trip Generation Person Trip Rates*

Land Use	Land Use Code	Peak	Peak Period	
			Vehicle Trip Rate	Person Trip Rates
Multi-Unit (High-Rise)	221 & 222 (TRANS)	AM	-	0.80
		PM	-	0.90

*Table 2: Total Person Trip Generation*

Land Use	Units	AM Peak Hour			PM Peak Hour		
		In	Out	Total	In	Out	Total
Multi-Unit (High-Rise)	113	17	35	50	29	21	49



# Appendix B

Turning Movement Counts



# Transportation Services - Traffic Services

## Turning Movement Count - Study Results

### LAURIER AVE @ NELSON ST

Survey Date: Wednesday, January 09, 2019

WO No: 38243

Start Time: 07:00

Device: Miovision

#### Full Study Diagram

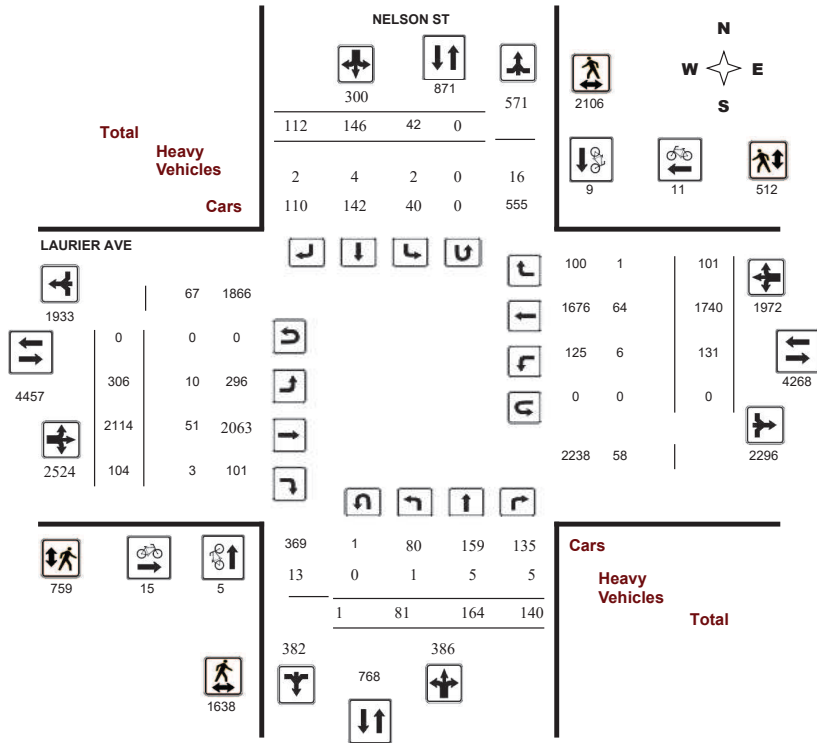

# Transportation Services - Traffic Services

## Turning Movement Count - Study Results

### LAURIER AVE @ NELSON ST

Survey Date: Wednesday, January 09, 2019

WO No: 38243

Start Time: 07:00

Device: Miovision

#### Full Study Peak Hour Diagram

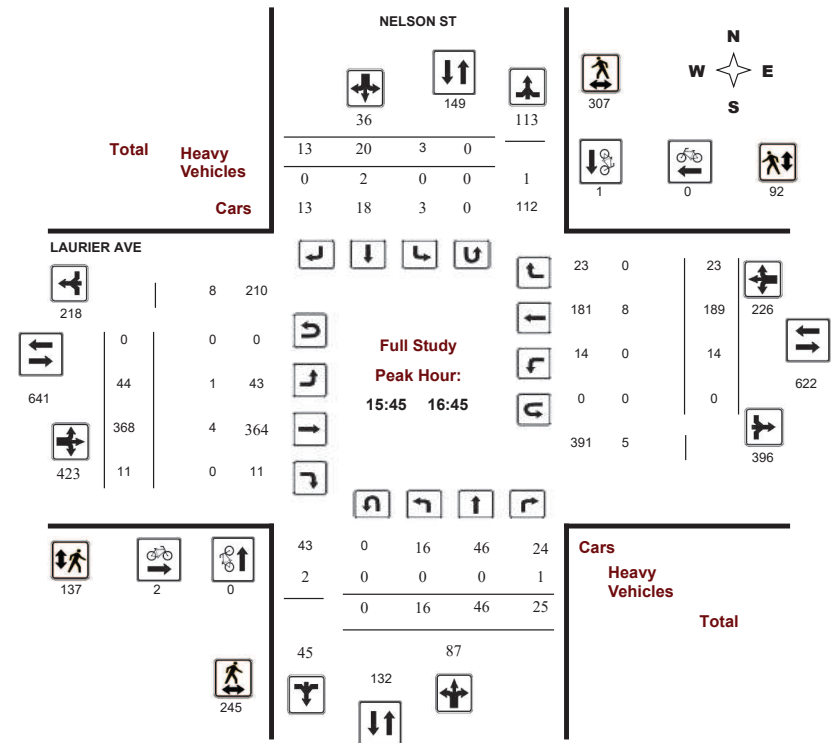



# Transportation Services - Traffic Services

## Turning Movement Count - Peak Hour Diagram

### LAURIER AVE @ NELSON ST

Survey Date: Wednesday, January 09, 2019

Start Time: 07:00

WO No: 38243

Device: Miovision

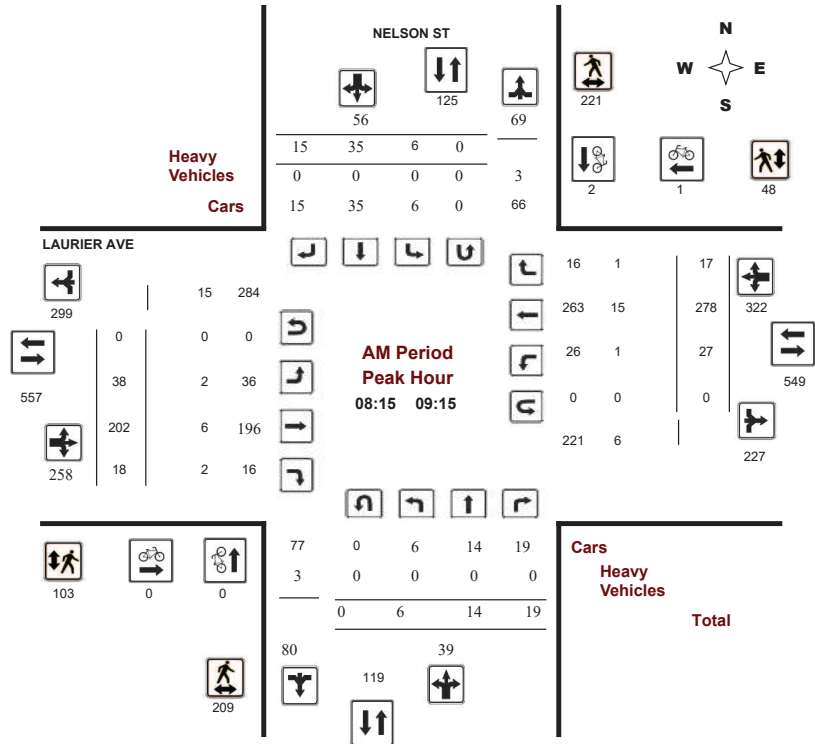

Comments



# Transportation Services - Traffic Services

## Turning Movement Count - Peak Hour Diagram

### LAURIER AVE @ NELSON ST

Survey Date: Wednesday, January 09, 2019

Start Time: 07:00

WO No: 38243

Device: Miovision

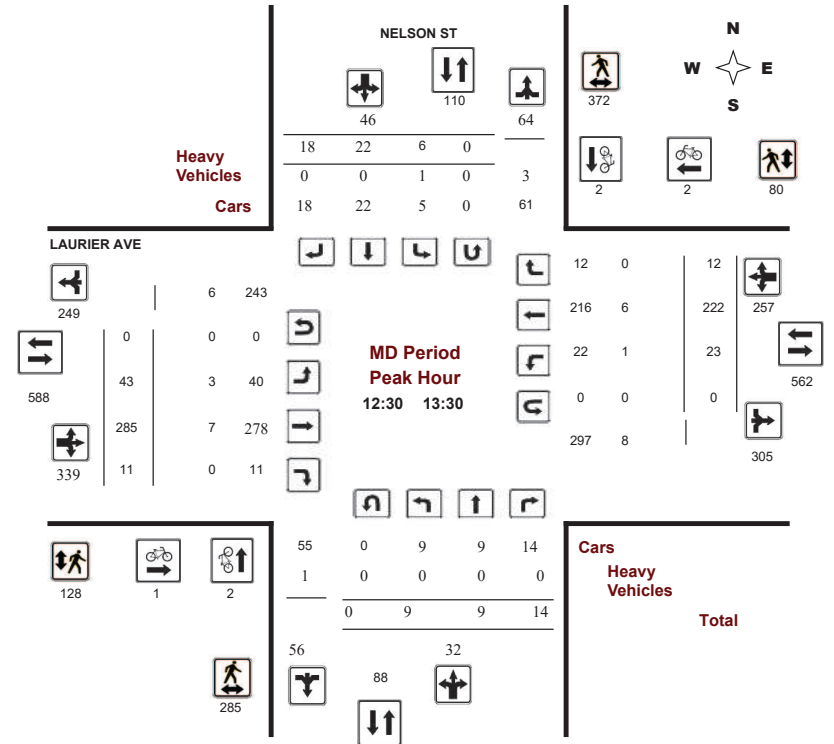

Comments



### Transportation Services - Traffic Services

#### Turning Movement Count - Peak Hour Diagram

##### LAURIER AVE @ NELSON ST

Survey Date: Wednesday, January 09, 2019

Start Time: 07:00

WO No: 38243

Device: Miovision

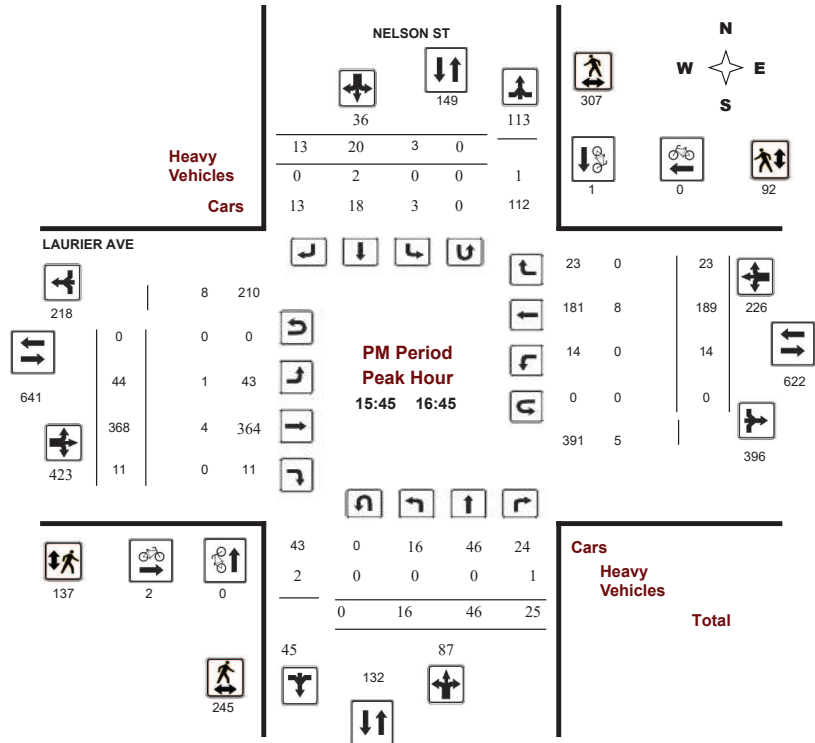

Comments



### Transportation Services - Traffic Services

#### Turning Movement Count - Study Results

##### LAURIER AVE @ NELSON ST

Survey Date: Wednesday, January 09, 2019

Start Time: 07:00

WO No: 38243

Device: Miovision

#### Full Study Summary (8 HR Standard)

Survey Date: Wednesday, January 09, 2019

**Total Observed U-Turns**

Northbound: 1    Southbound: 0  
Eastbound: 0    Westbound: 0

**AADT Factor** 1.00

Period	NELSON ST				LAURIER AVE								WB TOT	STR TOT	Grand Total				
	Northbound		Southbound		Eastbound			Westbound											
	LT	ST	RT	SB TOT	STR TOT	LT	ST	RT	EB TOT	LT	ST	RT							
07:00 08:00	5	10	7	22	1	5	19	25	47	20	158	13	191	8	209	5	222	413	460
08:00 09:00	5	15	19	39	5	38	19	62	101	35	192	21	248	23	260	14	297	545	646
09:00 10:00	5	11	11	27	6	17	9	32	59	33	216	13	262	11	265	11	287	549	608
11:30 12:30	11	10	20	41	6	12	9	27	68	44	231	15	290	13	189	6	208	498	566
12:30 13:30	9	9	14	32	6	22	18	46	78	43	285	11	339	23	222	12	257	596	674
15:00 16:00	18	30	22	70	7	12	11	30	100	41	298	5	344	31	218	11	260	604	704
16:00 17:00	16	45	29	90	4	20	14	38	128	45	367	14	426	7	179	23	209	635	763
17:00 18:00	12	34	18	64	7	20	13	40	104	45	367	12	424	15	198	19	232	656	760
<b>Sub Total</b>	<b>81</b>	<b>164</b>	<b>140</b>	<b>385</b>	<b>42</b>	<b>146</b>	<b>112</b>	<b>300</b>	<b>685</b>	<b>306</b>	<b>2114</b>	<b>104</b>	<b>2524</b>	<b>131</b>	<b>1740</b>	<b>101</b>	<b>1972</b>	<b>4496</b>	<b>5181</b>
<b>U Turns</b>				<b>1</b>				<b>0</b>	<b>1</b>				<b>0</b>				<b>0</b>	<b>0</b>	<b>1</b>
<b>Total</b>	<b>81</b>	<b>164</b>	<b>140</b>	<b>386</b>	<b>42</b>	<b>146</b>	<b>112</b>	<b>300</b>	<b>686</b>	<b>306</b>	<b>2114</b>	<b>104</b>	<b>2524</b>	<b>131</b>	<b>1740</b>	<b>101</b>	<b>1972</b>	<b>4496</b>	<b>5182</b>
<b>EQ 12Hr</b>	113	228	195	537	58	203	156	417	954	425	2938	145	3508	182	2419	140	2741	6249	7203

Note: These values are calculated by multiplying the totals by the appropriate expansion factor.

1.39

Note: These volumes are calculated by multiplying the Equivalent 12 hr. totals by the AADT factor.

1.00

Note: These volumes are calculated by multiplying the Average Daily 12 hr. totals by 12 to 24 expansion factor.

1.31

Note: U-Turns provided for approach totals. Refer to 'U-Turn' Report for specific breakdown.



Transportation Services - Traffic Services

Turning Movement Count - Study Results

LAURIER AVE @ NELSON ST

Survey Date: Wednesday, January 09, 2019

WO No: 38243

Start Time: 07:00

Device: Miovision

Full Study 15 Minute Increments

Table with columns for Time Period, Northbound, Southbound, Eastbound, Westbound, and Grand Total. Rows represent 15-minute intervals from 07:00 to 17:45.

Note: U-Turns are included in Totals.



Transportation Services - Traffic Services

Turning Movement Count - Study Results

LAURIER AVE @ NELSON ST

Survey Date: Wednesday, January 09, 2019

WO No: 38243

Start Time: 07:00

Device: Miovision

Full Study Cyclist Volume

Table with columns for Time Period, Northbound, Southbound, Street Total, Eastbound, Westbound, Street Total, and Grand Total. Rows represent 15-minute intervals from 07:00 to 17:45.



Transportation Services - Traffic Services

Turning Movement Count - Study Results

LAURIER AVE @ NELSON ST

Survey Date: Wednesday, January 09, 2019

WO No: 38243

Start Time: 07:00

Device: Miovision

Full Study Pedestrian Volume

NELSON ST LAURIER AVE

Table with columns: Time Period, NB Approach, SB Approach, Total, EB Approach, WB Approach, Grand Total. Rows show pedestrian volume for various time intervals from 07:00 to 17:45.



Transportation Services - Traffic Services

Turning Movement Count - Study Results

LAURIER AVE @ NELSON ST

Survey Date: Wednesday, January 09, 2019

WO No: 38243

Start Time: 07:00

Device: Miovision

Full Study Heavy Vehicles

NELSON ST LAURIER AVE

Table with columns: Time Period, Northbound, Southbound, Eastbound, Westbound, Grand Total. Rows show heavy vehicle volume for various time intervals from 07:00 to 17:45.



Transportation Services - Traffic Services

Turning Movement Count - Study Results

LAURIER AVE @ NELSON ST

Survey Date: Wednesday, January 09, 2019

WO No: 38243

Start Time: 07:00

Device: Miovision

Full Study 15 Minute U-Turn Total  
NELSON ST LAURIER AVE

Time Period	Northbound U-Turn Total	Southbound U-Turn Total	Eastbound U-Turn Total	Westbound U-Turn Total	Total
07:00 - 07:15	0	0	0	0	0
07:15 - 07:30	0	0	0	0	0
07:30 - 07:45	0	0	0	0	0
07:45 - 08:00	0	0	0	0	0
08:00 - 08:15	0	0	0	0	0
08:15 - 08:30	0	0	0	0	0
08:30 - 08:45	0	0	0	0	0
08:45 - 09:00	0	0	0	0	0
09:00 - 09:15	0	0	0	0	0
09:15 - 09:30	0	0	0	0	0
09:30 - 09:45	0	0	0	0	0
09:45 - 10:00	0	0	0	0	0
11:30 - 11:45	0	0	0	0	0
11:45 - 12:00	1	0	0	0	1
12:00 - 12:15	0	0	0	0	0
12:15 - 12:30	0	0	0	0	0
12:30 - 12:45	0	0	0	0	0
12:45 - 13:00	0	0	0	0	0
13:00 - 13:15	0	0	0	0	0
13:15 - 13:30	0	0	0	0	0
15:00 - 15:15	0	0	0	0	0
15:15 - 15:30	0	0	0	0	0
15:30 - 15:45	0	0	0	0	0
15:45 - 16:00	0	0	0	0	0
16:00 - 16:15	0	0	0	0	0
16:15 - 16:30	0	0	0	0	0
16:30 - 16:45	0	0	0	0	0
16:45 - 17:00	0	0	0	0	0
17:00 - 17:15	0	0	0	0	0
17:15 - 17:30	0	0	0	0	0
17:30 - 17:45	0	0	0	0	0
17:45 - 18:00	0	0	0	0	0
<b>Total</b>	<b>1</b>	<b>0</b>	<b>0</b>	<b>0</b>	<b>1</b>



Transportation Services - Traffic Services

Turning Movement Count - Study Results

LAURIER AVE @ SWEETLAND AVE

Survey Date: Wednesday, January 09, 2019

WO No: 38239

Start Time: 07:00

Device: Miovision

Full Study Diagram

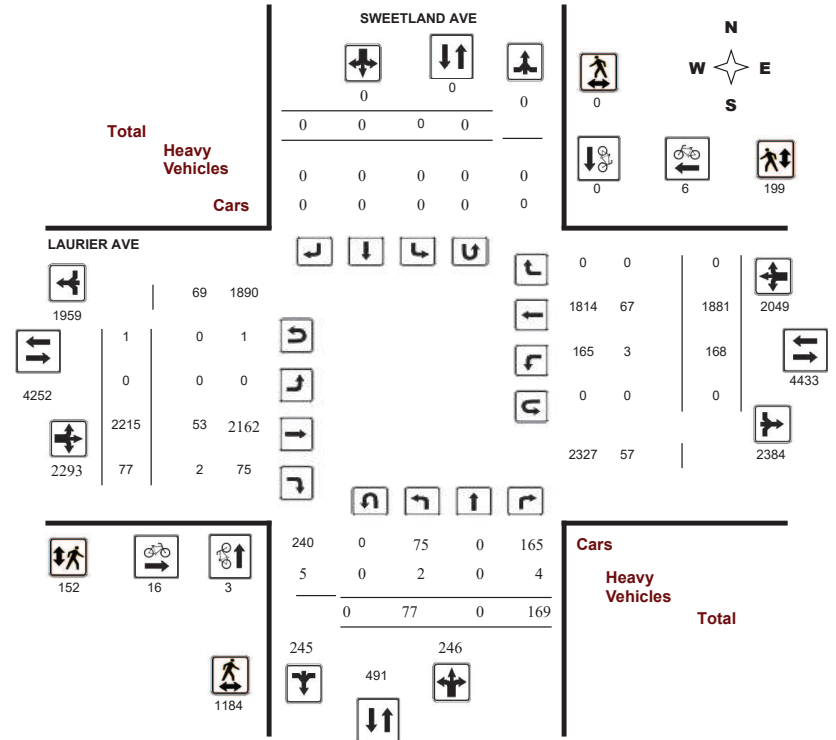



Transportation Services - Traffic Services

Turning Movement Count - Study Results

Laurier Ave @ Sweetland Ave

Survey Date: Wednesday, January 09, 2019

WO No: 38239

Start Time: 07:00

Device: Miovision

Full Study Peak Hour Diagram

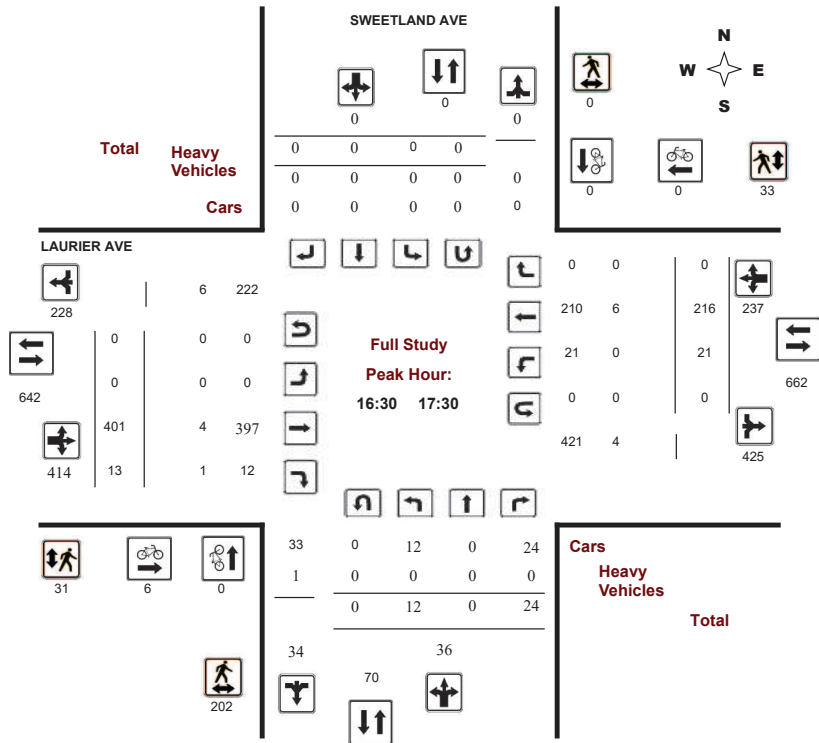

Transportation Services - Traffic Services

Turning Movement Count - Peak Hour Diagram

Laurier Ave @ Sweetland Ave

Survey Date: Wednesday, January 09, 2019

WO No: 38239

Start Time: 07:00

Device: Miovision

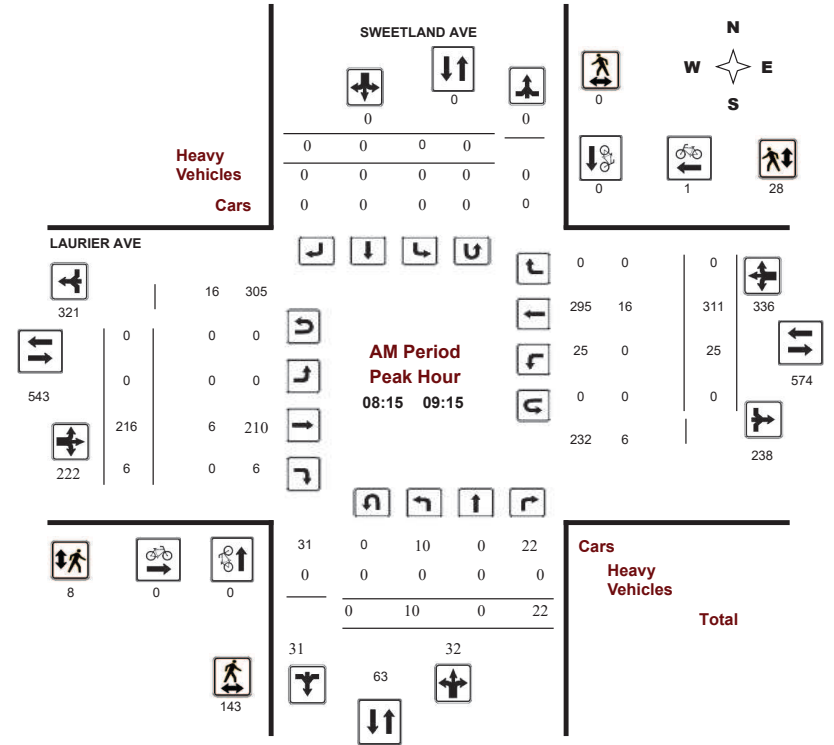

Comments





# Transportation Services - Traffic Services

## Turning Movement Count - Peak Hour Diagram

### LAURIER AVE @ SWEETLAND AVE

Survey Date: Wednesday, January 09, 2019

Start Time: 07:00

WO No: 38239

Device: Miovision

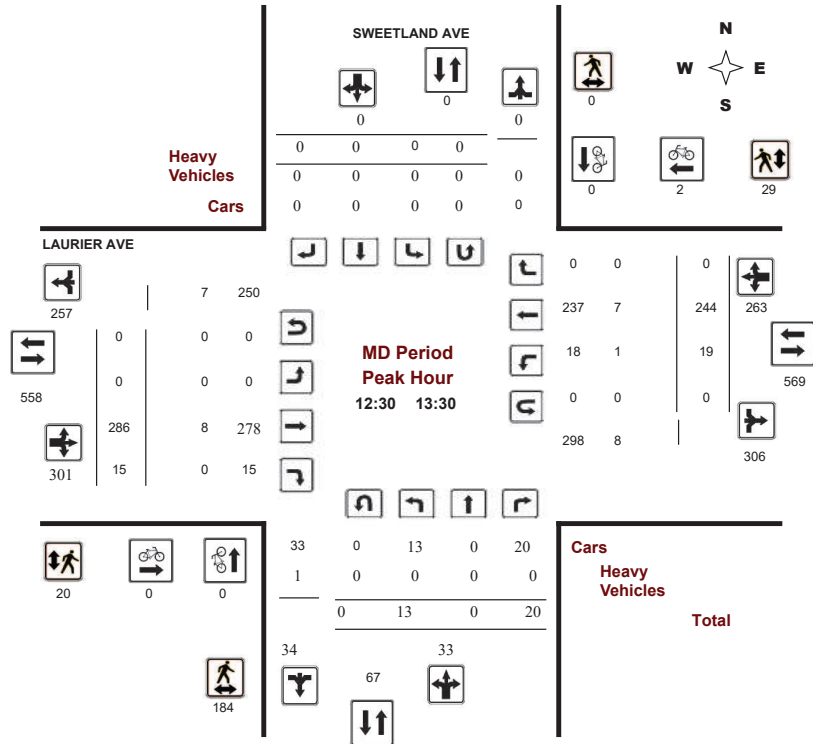

Comments



# Transportation Services - Traffic Services

## Turning Movement Count - Peak Hour Diagram

### LAURIER AVE @ SWEETLAND AVE

Survey Date: Wednesday, January 09, 2019

Start Time: 07:00

WO No: 38239

Device: Miovision

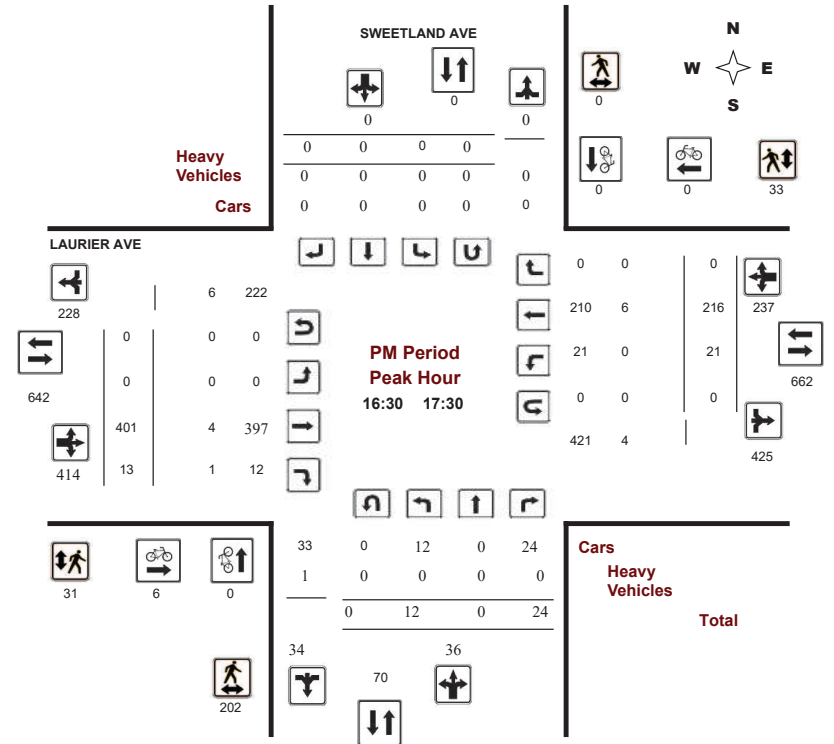

Comments



Transportation Services - Traffic Services

Turning Movement Count - Study Results

LAURIER AVE @ SWEETLAND AVE

Survey Date: Wednesday, January 09, 2019

WO No: 38239

Start Time: 07:00

Device: Miovision

Full Study Summary (8 HR Standard)

Survey Date: Wednesday, January 09, 2019

Total Observed U-Turns

AADT Factor

Northbound: 0 Southbound: 0
Eastbound: 1 Westbound: 0

1.00

Table with columns for Period, Sweetland Ave (Northbound, Southbound), Laurier Ave (Eastbound, Westbound), and Grand Total. Includes sub-totals for U-Turns and EQ 12Hr, and AVG 12Hr, and AVG 24Hr.

Note: These values are calculated by multiplying the totals by the appropriate expansion factor.

1.39

Note: These volumes are calculated by multiplying the Equivalent 12 hr. totals by the AADT factor.

1.00

Note: These volumes are calculated by multiplying the Average Daily 12 hr. totals by 12 to 24 expansion factor.

1.31

Note: U-Turns provided for approach totals. Refer to 'U-Turn' Report for specific breakdown.



Transportation Services - Traffic Services

Turning Movement Count - Study Results

LAURIER AVE @ SWEETLAND AVE

Survey Date: Wednesday, January 09, 2019

WO No: 38239

Start Time: 07:00

Device: Miovision

Full Study 15 Minute Increments

Large table showing 15-minute increments for Sweetland Ave and Laurier Ave. Columns include Time Period, Northbound (LT, ST, RT, N TOT), Southbound (LT, ST, RT, S TOT), Eastbound (LT, ST, RT, E TOT), Westbound (LT, ST, RT, W TOT), and Grand Total.

Note: U-Turns are included in Totals.



Transportation Services - Traffic Services

Turning Movement Count - Study Results

LAURIER AVE @ SWEETLAND AVE

Survey Date: Wednesday, January 09, 2019

WO No: 38239

Start Time: 07:00

Device: Miovision

Full Study Cyclist Volume

Table with columns: Time Period, Northbound, Southbound, Street Total, Eastbound, Westbound, Street Total, Grand Total. Rows show cyclist volume data for Sweetland Ave and Laurier Ave from 07:00 to 18:00.



Transportation Services - Traffic Services

Turning Movement Count - Study Results

LAURIER AVE @ SWEETLAND AVE

Survey Date: Wednesday, January 09, 2019

WO No: 38239

Start Time: 07:00

Device: Miovision

Full Study Pedestrian Volume

Table with columns: Time Period, NB Approach, SB Approach, Total, EB Approach, WB Approach, Total, Grand Total. Rows show pedestrian volume data for Sweetland Ave and Laurier Ave from 07:00 to 18:00.



Transportation Services - Traffic Services

Turning Movement Count - Study Results

LAURIER AVE @ SWEETLAND AVE

Survey Date: Wednesday, January 09, 2019

WO No: 38239

Start Time: 07:00

Device: Miovision

Full Study Heavy Vehicles

SWEETLAND AVE				LAURIER AVE				SWEETLAND AVE				LAURIER AVE				Grand Total			
Northbound		Southbound		Eastbound		Westbound		Northbound		Southbound		Eastbound		Westbound					
Time Period	LT	ST	RT	N TOT	LT	ST	RT	S TOT	STR TOT	LT	ST	RT	E TOT	LT	ST	RT	W TOT	STR TOT	
07:00	07:15	0	0	0	0	0	0	0	0	0	1	0	5	0	4	0	5	10	5
07:15	07:30	1	0	0	2	0	0	0	2	0	2	1	5	0	1	0	3	8	5
07:30	07:45	0	0	0	1	0	0	0	1	0	1	0	4	1	3	0	5	9	5
07:45	08:00	0	0	0	0	0	0	0	0	0	1	0	2	0	1	0	2	4	2
08:00	08:15	0	0	0	0	0	0	0	0	0	1	0	3	0	2	0	3	6	3
08:15	08:30	0	0	0	0	0	0	0	0	0	3	0	9	0	6	0	9	18	9
08:30	08:45	0	0	0	0	0	0	0	0	0	0	0	3	0	3	0	3	6	3
08:45	09:00	0	0	0	0	0	0	0	0	0	2	0	3	0	1	0	3	6	3
09:00	09:15	0	0	0	0	0	0	0	0	0	1	0	7	0	6	0	7	14	7
09:15	09:30	1	0	0	1	0	0	0	1	0	3	0	5	0	1	0	4	9	5
09:30	09:45	0	0	0	0	0	0	0	0	0	5	0	7	0	2	0	7	14	7
09:45	10:00	0	0	1	1	0	0	0	1	0	2	0	4	0	2	0	5	9	5
11:30	11:45	0	0	0	0	0	0	0	0	0	0	0	3	0	3	0	3	6	3
11:45	12:00	0	0	0	0	0	0	0	0	0	1	0	2	0	1	0	2	4	2
12:00	12:15	0	0	0	0	0	0	0	0	0	1	0	2	0	1	0	2	4	2
12:15	12:30	0	0	0	0	0	0	0	0	0	3	0	4	0	1	0	4	8	4
12:30	12:45	0	0	0	0	0	0	0	0	0	1	0	5	0	4	0	5	10	5
12:45	13:00	0	0	0	0	0	0	0	0	0	2	0	3	0	1	0	3	6	3
13:00	13:15	0	0	0	1	0	0	0	1	0	3	0	4	1	1	0	5	9	5
13:15	13:30	0	0	0	0	0	0	0	0	0	2	0	3	0	1	0	3	6	3
15:00	15:15	0	0	0	1	0	0	0	1	0	3	0	7	1	4	0	8	15	8
15:15	15:30	0	0	0	0	0	0	0	0	0	1	0	2	0	1	0	2	4	2
15:30	15:45	0	0	3	3	0	0	0	3	0	2	0	3	0	1	0	6	9	6
15:45	16:00	0	0	0	0	0	0	0	0	0	2	0	4	0	2	0	4	8	4
16:00	16:15	0	0	0	0	0	0	0	0	0	1	0	3	0	2	0	3	6	3
16:15	16:30	0	0	0	0	0	0	0	0	0	1	0	2	0	1	0	2	4	2
16:30	16:45	0	0	0	0	0	0	0	0	0	1	0	4	0	3	0	4	8	4
16:45	17:00	0	0	0	0	0	0	0	0	0	2	0	3	0	1	0	3	6	3
17:00	17:15	0	0	0	1	0	0	0	1	0	1	1	3	0	1	0	2	5	3
17:15	17:30	0	0	0	0	0	0	0	0	0	0	0	1	0	1	0	1	2	1
17:30	17:45	0	0	0	0	0	0	0	0	0	2	0	5	0	3	0	5	10	5
17:45	18:00	0	0	0	0	0	0	0	0	0	2	0	4	0	2	0	4	8	4
Total:	None	2	0	4	11	0	0	0	11	0	53	2	124	3	67	0	127	251	131



Transportation Services - Traffic Services

Turning Movement Count - Study Results

LAURIER AVE @ SWEETLAND AVE

Survey Date: Wednesday, January 09, 2019

WO No: 38239

Start Time: 07:00

Device: Miovision

Full Study 15 Minute U-Turn Total

SWEETLAND AVE		LAURIER AVE		Total		
Northbound U-Turn Total	Southbound U-Turn Total	Eastbound U-Turn Total	Westbound U-Turn Total			
Time Period	Time Period	Northbound U-Turn Total	Southbound U-Turn Total	Eastbound U-Turn Total	Westbound U-Turn Total	Total
07:00	07:15	0	0	0	0	0
07:15	07:30	0	0	0	0	0
07:30	07:45	0	0	0	0	0
07:45	08:00	0	0	1	0	1
08:00	08:15	0	0	0	0	0
08:15	08:30	0	0	0	0	0
08:30	08:45	0	0	0	0	0
08:45	09:00	0	0	0	0	0
09:00	09:15	0	0	0	0	0
09:15	09:30	1	0	0	0	1
09:30	09:45	0	0	0	0	0
09:45	10:00	0	0	0	0	0
11:30	11:45	0	0	0	0	0
11:45	12:00	0	0	0	0	0
12:00	12:15	0	0	0	0	0
12:15	12:30	0	0	0	0	0
12:30	12:45	0	0	0	0	0
12:45	13:00	0	0	0	0	0
13:00	13:15	0	0	0	0	0
13:15	13:30	0	0	0	0	0
15:00	15:15	0	0	0	0	0
15:15	15:30	0	0	0	0	0
15:30	15:45	0	0	0	0	0
15:45	16:00	0	0	0	0	0
16:00	16:15	0	0	0	0	0
16:15	16:30	0	0	0	0	0
16:30	16:45	0	0	0	0	0
16:45	17:00	0	0	0	0	0
17:00	17:15	0	0	0	0	0
17:15	17:30	0	0	0	0	0
17:30	17:45	0	0	0	0	0
17:45	18:00	0	0	0	0	0
Total	Total	0	0	1	0	1



# Transportation Services - Traffic Services

## Turning Movement Count - Study Results

### CHAPEL ST @ LAURIER AVE

Survey Date: Tuesday, January 11, 2022

WO No: 40029

Start Time: 07:00

Device: Miovision

#### Full Study Diagram

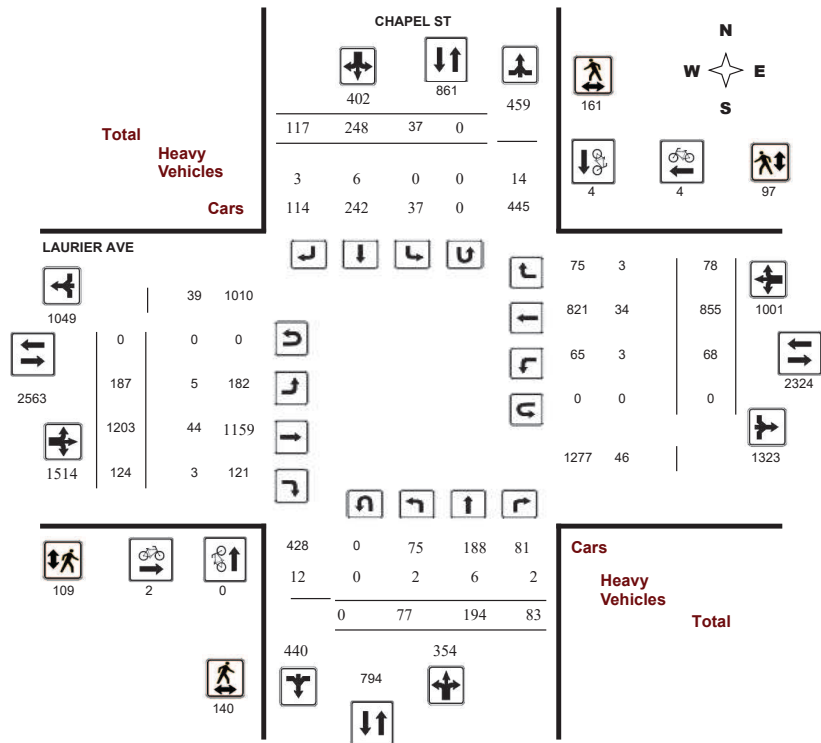

# Transportation Services - Traffic Services

## Turning Movement Count - Study Results

### CHAPEL ST @ LAURIER AVE

Survey Date: Tuesday, January 11, 2022

WO No: 40029

Start Time: 07:00

Device: Miovision

#### Full Study Peak Hour Diagram

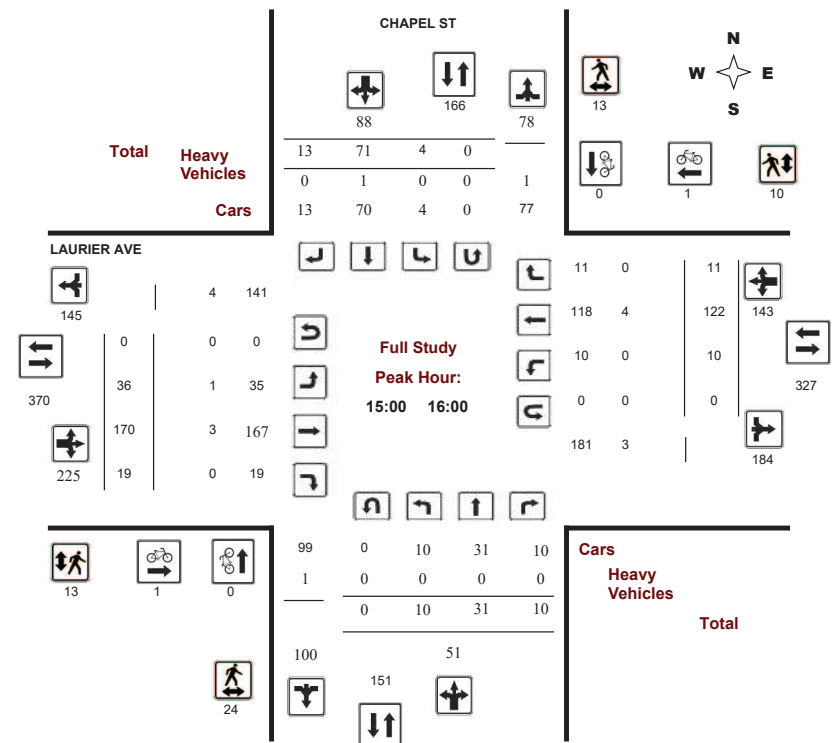



# Transportation Services - Traffic Services

## Turning Movement Count - Peak Hour Diagram

### CHAPEL ST @ LAURIER AVE

Survey Date: Tuesday, January 11, 2022

Start Time: 07:00

WO No: 40029

Device: Miovision

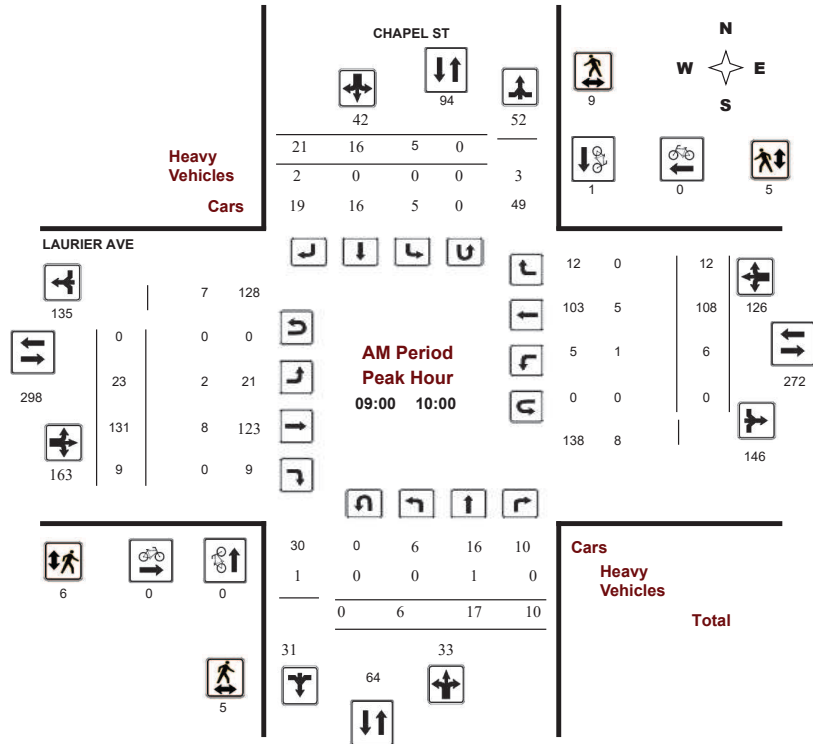

# Transportation Services - Traffic Services

## Turning Movement Count - Peak Hour Diagram

### CHAPEL ST @ LAURIER AVE

Survey Date: Tuesday, January 11, 2022

Start Time: 07:00

WO No: 40029

Device: Miovision

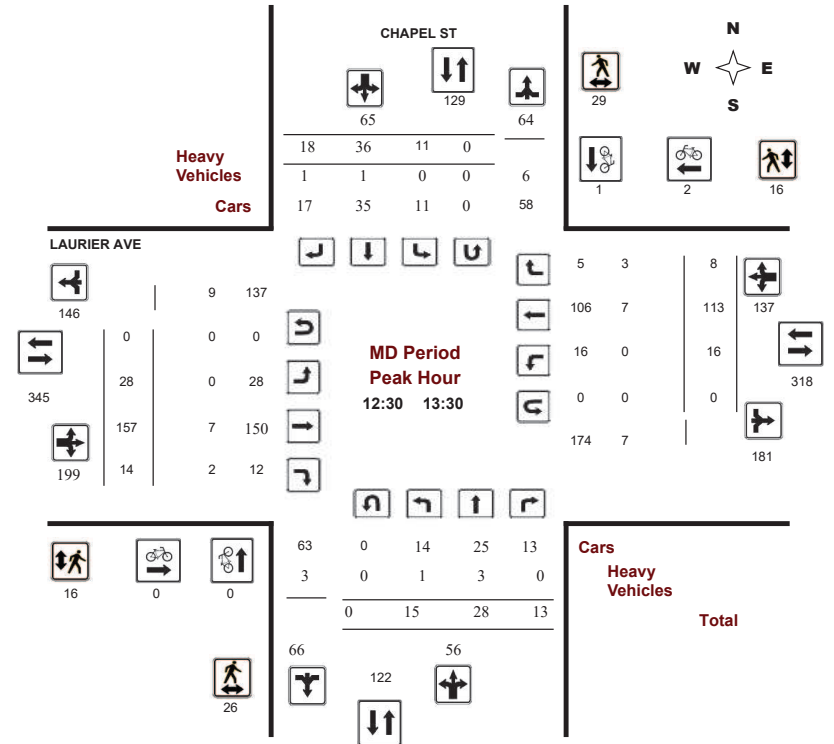



# Transportation Services - Traffic Services

## Turning Movement Count - Peak Hour Diagram

### CHAPEL ST @ LAURIER AVE

Survey Date: Tuesday, January 11, 2022  
Start Time: 07:00

WO No: 40029  
Device: Miovision

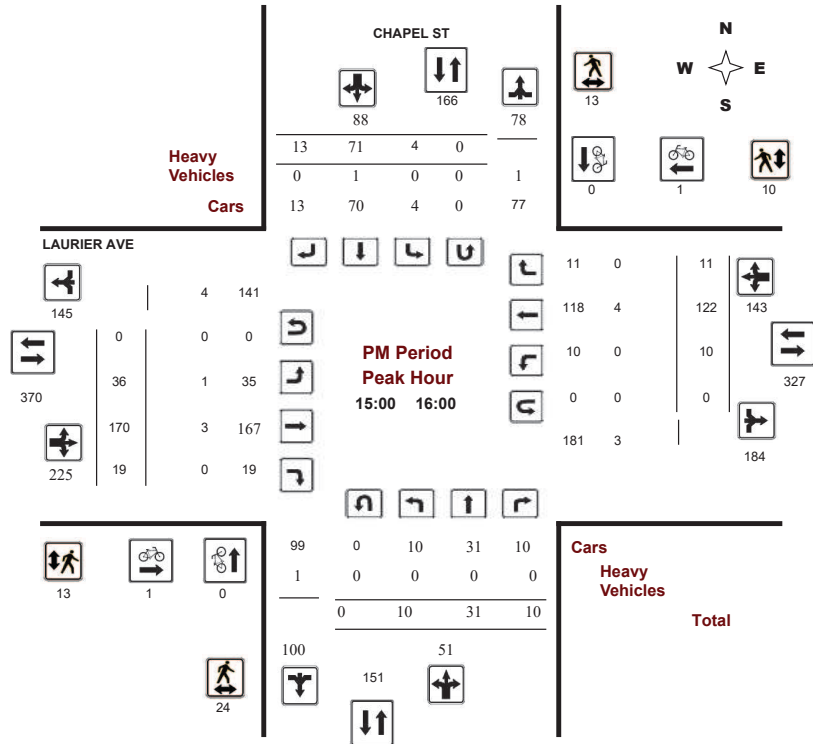

# Transportation Services - Traffic Services

## Turning Movement Count - Study Results

### CHAPEL ST @ LAURIER AVE

Survey Date: Tuesday, January 11, 2022  
Start Time: 07:00

WO No: 40029  
Device: Miovision

### Full Study Summary (8 HR Standard)

Survey Date: Tuesday, January 11, 2022

Total Observed U-Turns  
Northbound: 0 Southbound: 0  
Eastbound: 0 Westbound: 0

AADT Factor  
1.10

Period	CHAPEL ST								LAURIER AVE								WB TOT	STR TOT	Grand Total
	Northbound				Southbound				Eastbound				Westbound						
	LT	ST	RT	NB TOT	LT	ST	RT	SB TOT	STR TOT	LT	ST	RT	EB TOT	LT	ST	RT			
07:00 08:00	6	9	2	17	3	17	8	28	45	8	101	5	114	5	70	4	79	193	238
08:00 09:00	6	22	8	36	3	19	9	31	67	15	122	17	154	6	102	3	111	265	332
09:00 10:00	6	17	10	33	5	16	21	42	75	23	131	9	163	6	108	12	126	289	364
11:30 12:30	10	19	13	42	3	21	22	46	88	22	148	20	190	8	104	11	123	313	401
12:30 13:30	15	28	13	56	11	36	18	65	121	28	157	14	199	16	113	8	137	336	457
15:00 16:00	10	31	10	51	4	71	13	88	139	36	170	19	225	10	122	11	143	368	507
16:00 17:00	9	34	14	57	6	26	6	38	95	26	184	17	227	6	123	15	144	371	466
17:00 18:00	15	34	13	62	2	42	20	64	126	29	190	23	242	11	113	14	138	380	506
<b>Sub Total</b>	<b>77</b>	<b>194</b>	<b>83</b>	<b>354</b>	<b>37</b>	<b>248</b>	<b>117</b>	<b>402</b>	<b>756</b>	<b>187</b>	<b>1203</b>	<b>124</b>	<b>1514</b>	<b>68</b>	<b>855</b>	<b>78</b>	<b>1001</b>	<b>2515</b>	<b>3271</b>
<b>U Turns</b>	<b>0</b>	<b>0</b>	<b>0</b>	<b>0</b>	<b>0</b>	<b>0</b>	<b>0</b>	<b>0</b>	<b>0</b>	<b>0</b>	<b>0</b>	<b>0</b>	<b>0</b>	<b>0</b>	<b>0</b>	<b>0</b>	<b>0</b>	<b>0</b>	<b>0</b>
<b>Total</b>	<b>77</b>	<b>194</b>	<b>83</b>	<b>354</b>	<b>37</b>	<b>248</b>	<b>117</b>	<b>402</b>	<b>756</b>	<b>187</b>	<b>1203</b>	<b>124</b>	<b>1514</b>	<b>68</b>	<b>855</b>	<b>78</b>	<b>1001</b>	<b>2515</b>	<b>3271</b>
<b>EQ 12Hr</b>	<b>107</b>	<b>270</b>	<b>115</b>	<b>492</b>	<b>51</b>	<b>345</b>	<b>163</b>	<b>559</b>	<b>1051</b>	<b>260</b>	<b>1672</b>	<b>172</b>	<b>2104</b>	<b>95</b>	<b>1188</b>	<b>108</b>	<b>1391</b>	<b>3496</b>	<b>4547</b>
Note: These values are calculated by multiplying the totals by the appropriate expansion factor.	<b>1.39</b>																		
<b>AVG 12Hr</b>	<b>118</b>	<b>297</b>	<b>127</b>	<b>541</b>	<b>56</b>	<b>497</b>	<b>234</b>	<b>615</b>	<b>1156</b>	<b>286</b>	<b>1839</b>	<b>189</b>	<b>2314</b>	<b>105</b>	<b>1307</b>	<b>119</b>	<b>1530</b>	<b>3846</b>	<b>5002</b>
Note: These volumes are calculated by multiplying the Equivalent 12 hr. totals by the AADT factor.	<b>1.10</b>																		
<b>AVG 24Hr</b>	<b>155</b>	<b>389</b>	<b>166</b>	<b>709</b>	<b>73</b>	<b>651</b>	<b>307</b>	<b>806</b>	<b>1514</b>	<b>375</b>	<b>2409</b>	<b>248</b>	<b>3031</b>	<b>138</b>	<b>1712</b>	<b>156</b>	<b>2004</b>	<b>5038</b>	<b>6553</b>
Note: These volumes are calculated by multiplying the Average Daily 12 hr. totals by 12 to 24 expansion factor.	<b>1.31</b>																		
Note: U-Turns provided for approach totals. Refer to 'U-Turn' Report for specific breakdown.																			



Transportation Services - Traffic Services

Turning Movement Count - Study Results

CHAPEL ST @ LAURIER AVE

Survey Date: Tuesday, January 11, 2022

WO No: 40029

Start Time: 07:00

Device: Miovision

Full Study 15 Minute Increments

Table with columns for Time Period, Northbound (LT, ST, RT, N TOT, STR TOT), Southbound (LT, ST, RT, S TOT, STR TOT), Eastbound (LT, ST, RT, E TOT), Westbound (LT, ST, RT, W TOT, STR TOT), and Grand Total. Rows represent 15-minute intervals from 07:00 to 17:45.

Note: U-Turns are included in Totals.



Transportation Services - Traffic Services

Turning Movement Count - Study Results

CHAPEL ST @ LAURIER AVE

Survey Date: Tuesday, January 11, 2022

WO No: 40029

Start Time: 07:00

Device: Miovision

Full Study Cyclist Volume

Table with columns for Time Period, Chapel St (Northbound, Southbound, Street Total), Laurier Ave (Eastbound, Westbound, Street Total), and Grand Total. Rows represent 15-minute intervals from 07:00 to 17:45.





Transportation Services - Traffic Services

Turning Movement Count - Study Results

CHAPEL ST @ LAURIER AVE

Survey Date: Tuesday, January 11, 2022

WO No: 40029

Start Time: 07:00

Device: Miovision

Full Study Pedestrian Volume

CHAPEL ST LAURIER AVE

Table with columns: Time Period, NB Approach, SB Approach, Total, EB Approach, WB Approach, Grand Total. Rows show pedestrian counts for various time intervals from 07:00 to 17:45.



Transportation Services - Traffic Services

Turning Movement Count - Study Results

CHAPEL ST @ LAURIER AVE

Survey Date: Tuesday, January 11, 2022

WO No: 40029

Start Time: 07:00

Device: Miovision

Full Study Heavy Vehicles

CHAPEL ST LAURIER AVE

Table with columns: Time Period, Northbound (LT, ST, RT, N TOT), Southbound (LT, ST, RT, S TOT, STR TOT), Eastbound (LT, ST, RT, E TOT), Westbound (LT, ST, RT, W TOT, STR TOT), Grand Total. Rows show heavy vehicle counts for various time intervals from 07:00 to 17:45.



Transportation Services - Traffic Services

Turning Movement Count - Study Results

CHAPEL ST @ LAURIER AVE

Survey Date: Tuesday, January 11, 2022

WO No: 40029

Start Time: 07:00

Device: Miovision

Full Study 15 Minute U-Turn Total

CHAPEL ST LAURIER AVE

Table with columns: Time Period, Northbound U-Turn Total, Southbound U-Turn Total, Eastbound U-Turn Total, Westbound U-Turn Total, Total. Rows show 15-minute intervals from 07:00 to 17:45.



Turning Movement Count Summary Report Including AM and PM Peak Hours All Vehicles Except Bicycles



Blackburn Avenue & Laurier Avenue East Ottawa, ON

Survey Date: Tuesday, March 07, 2023

Start Time: 0700 AADT Factor: 1.0

Weather AM: Mostly Cloudy -8° C

Survey Duration: 6 Hrs. Survey Hours: 0700-1000 & 1500-1800

Weather PM: Overcast -4° C

Surveyor(s): T. Carmody

Summary table for Laurier Ave. (E), Blackburn Ave., and Apt. Access with columns for Eastbound, Westbound, Northbound, Southbound.

Main traffic volume table with columns: Time Period, LT, ST, RT, UT, E/B Tot, W/B Tot, Street Total, N/B Tot, S/B Tot, Street Total, Grand Total.

Equivalent 12 & 24-hour Vehicle Volumes Including the Annual Average Daily Traffic (AADT) Factor

Expansion factors are applied exclusively to standard weekday 8-hour turning movement counts conducted during the hours of 0700h - 1000h, 1130h - 1330h and 1500h - 1800h

Table showing Equivalent 12-hour and Average daily 12-hour vehicle volumes with columns for Equ. 12 Hr and AADT 12-hr.

AADT and expansion factors provided by the City of Ottawa

Table for AM Peak Hour Factor (0.93) and Highest Hourly Vehicle Volume Between 0700h & 1000h.

Table for PM Peak Hour Factor (0.89) and Highest Hourly Vehicle Volume Between 1500h & 1800h.

Comments:

OC Transpo, Para Transpo buses and school buses comprise 41.89% of the heavy vehicle traffic. There were 4 vehicle/vehicle conflicts involving northbound left-turning vehicles from Blackburn Avenue & eastbound through vehicles on Laurier Avenue (E) at: 1646h, 1707h, 1729h & 1749h.

Notes:

- 1. Includes all vehicle types except bicycles, electric bicycles, and electric scooters.
2. When expansion and AADT factors are applied, the results will differ slightly due to rounding.



### Turning Movement Count Summary, AM and PM Peak Hour Flow Diagrams All Vehicles Except Bicycles



#### Blackburn Avenue & Laurier Avenue East Ottawa, ON

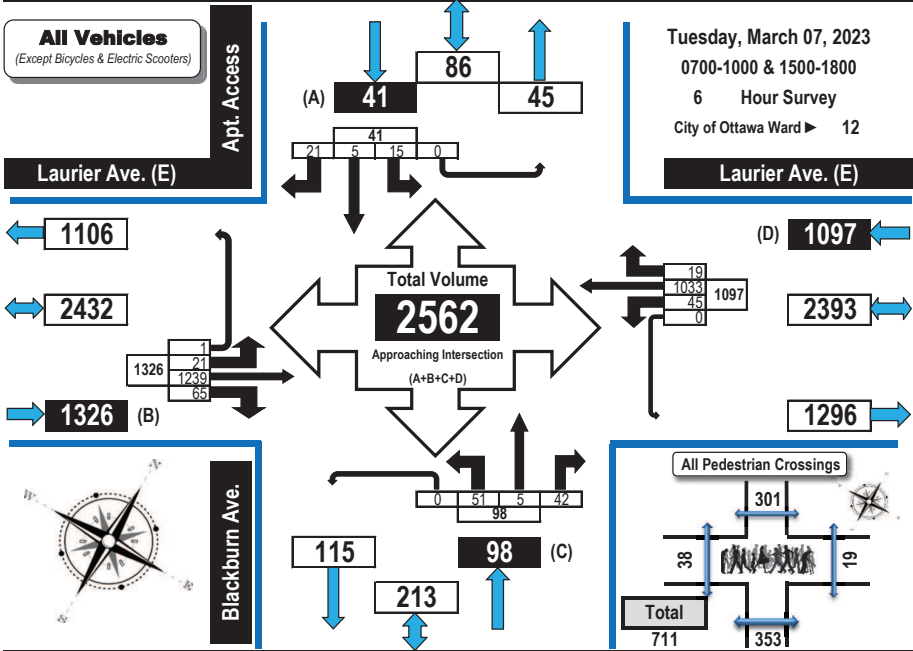

AM Peak Hour Flow Diagram

PM Peak Hour Flow Diagram

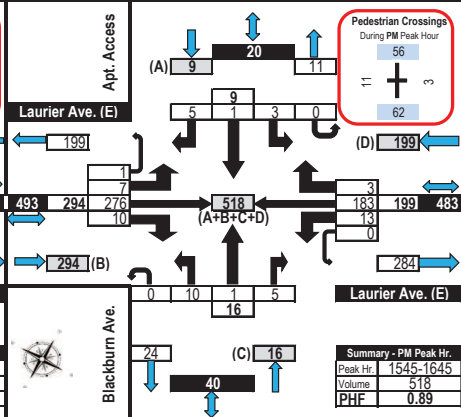
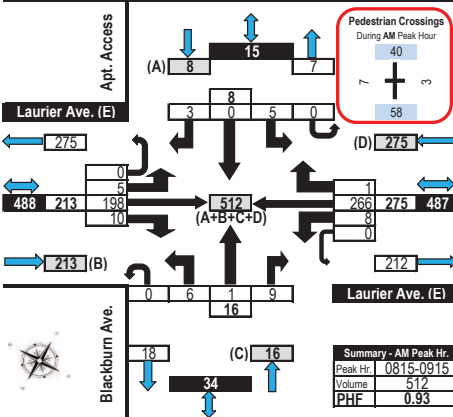

### Turning Movement Count Heavy Vehicle Summary (FHWA Class 4-13) Flow Diagram



#### Blackburn Avenue & Laurier Avenue East Ottawa, ON

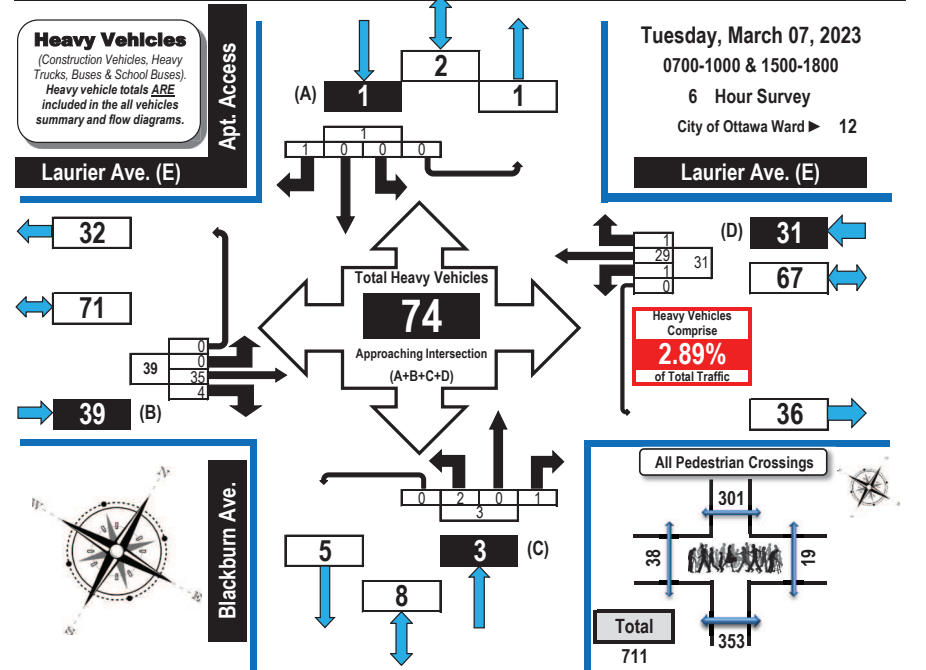

Time Period	Laurier Ave. (E) Eastbound				Laurier Ave. (E) Westbound				Blackburn Ave. Northbound				Apt. Access Southbound				SB Tot	GR Tot				
	LT	ST	RT	UT	LT	ST	RT	UT	WB Tot	LT	ST	RT	UT	NB Tot	LT	ST			RT	UT		
0700-0800	0	9	1	0	10	0	8	0	0	8	0	0	0	0	0	0	0	0	0	0	0	18
0800-0900	0	6	0	0	6	0	6	0	0	6	1	0	0	0	1	0	0	0	0	0	0	13
0900-1000	0	5	2	0	7	1	6	0	0	7	0	0	1	0	1	0	0	0	0	0	0	15
1500-1600	0	6	0	0	6	0	4	1	0	5	1	0	0	0	1	0	0	1	0	0	1	13
1600-1700	0	5	0	0	5	0	4	0	0	4	0	0	0	0	0	0	0	0	0	0	0	9
1700-1800	0	4	1	0	5	0	1	0	0	1	0	0	0	0	0	0	0	0	0	0	0	6
<b>Totals</b>	<b>0</b>	<b>35</b>	<b>4</b>	<b>0</b>	<b>39</b>	<b>1</b>	<b>29</b>	<b>1</b>	<b>0</b>	<b>31</b>	<b>2</b>	<b>0</b>	<b>1</b>	<b>0</b>	<b>3</b>	<b>0</b>	<b>0</b>	<b>1</b>	<b>0</b>	<b>1</b>	<b>0</b>	<b>74</b>

**Comments:**

OC Transpo, Para Transpo buses and school buses comprise 41.89% of the heavy vehicle traffic. There were 4 vehicle/vehicle conflicts involving northbound left-turning vehicles from Blackburn Avenue & eastbound through vehicles on Laurier Avenue (E) at: 1646h, 1707h, 1729h & 1749h. The pedestrian crossings totals include 2 pedestrians with accessibility issues using either a cane or walker.



### Turning Movement Count All Buses Summary (FHWA Class 4 ONLY) Flow Diagram



#### Blackburn Avenue & Laurier Avenue East Ottawa, ON

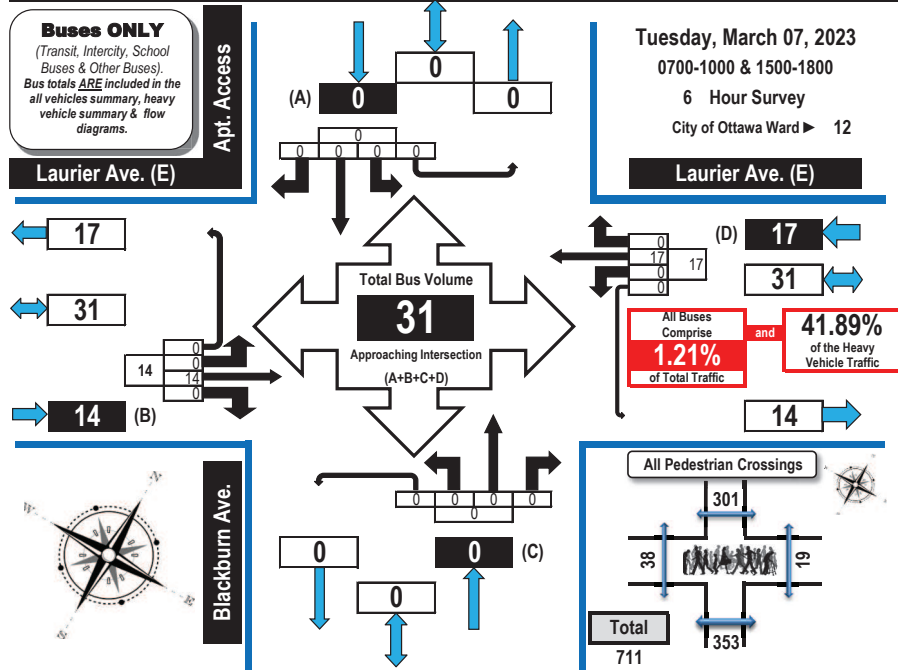

Time Period	Laurier Ave. (E) Eastbound				Laurier Ave. (E) Westbound				Blackburn Ave. Northbound				Apt. Access Southbound				SB Tot	GR Tot				
	LT	ST	RT	UT	LT	ST	RT	UT	LT	ST	RT	UT	LT	ST	RT	UT						
	EB Tot				WB Tot				NB Tot				SB Tot									
0700-0800	0	3	0	0	3	0	3	0	0	3	0	0	0	0	0	0	0	0	0	0	0	6
0800-0900	0	2	0	0	2	0	3	0	0	3	0	0	0	0	0	0	0	0	0	0	0	5
0900-1000	0	3	0	0	3	0	2	0	0	2	0	0	0	0	0	0	0	0	0	0	0	5
1500-1600	0	2	0	0	2	0	4	0	0	4	0	0	0	0	0	0	0	0	0	0	0	6
1600-1700	0	2	0	0	2	0	4	0	0	4	0	0	0	0	0	0	0	0	0	0	0	6
1700-1800	0	2	0	0	2	0	1	0	0	1	0	0	0	0	0	0	0	0	0	0	0	3
<b>Totals</b>	<b>0</b>	<b>14</b>	<b>0</b>	<b>0</b>	<b>14</b>	<b>0</b>	<b>17</b>	<b>0</b>	<b>17</b>	<b>0</b>	<b>0</b>	<b>0</b>	<b>0</b>	<b>0</b>	<b>0</b>	<b>0</b>	<b>0</b>	<b>0</b>	<b>0</b>	<b>0</b>	<b>0</b>	<b>31</b>

**Comments:**  
OC Transpo, Para Transpo buses and school buses comprise 41.89% of the heavy vehicle traffic. There were 4 vehicle/vehicle conflicts involving northbound left-turning vehicles from Blackburn Avenue & eastbound through vehicles on Laurier Avenue (E) at: 1646h, 1707h, 1729h & 1749h. The pedestrian crossings totals include 2 pedestrians with accessibility issues using either a cane or walker.



### Turning Movement Count Bicycle Summary Flow Diagram



#### Blackburn Avenue & Laurier Avenue East Ottawa, ON

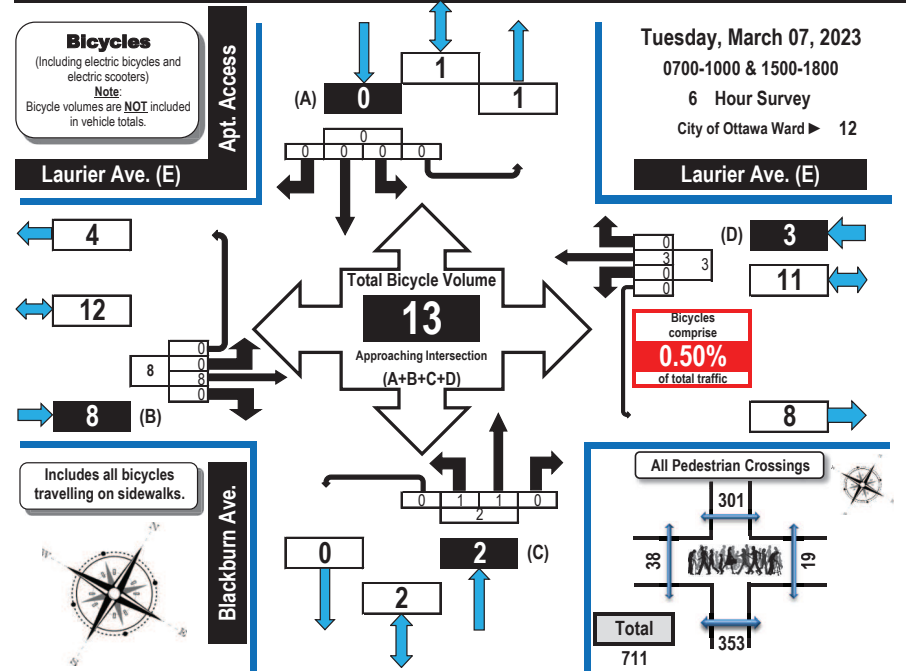

Time Period	Laurier Ave. (E) Eastbound				Laurier Ave. (E) Westbound				Blackburn Ave. Northbound				Apt. Access Southbound				SB Tot	GR Tot				
	LT	ST	RT	UT	LT	ST	RT	UT	LT	ST	RT	UT	LT	ST	RT	UT						
	EB Tot				WB Tot				NB Tot				SB Tot									
0700-0800	0	0	0	0	0	0	0	0	0	1	0	0	1	0	0	0	0	0	0	0	0	1
0800-0900	0	0	0	0	0	0	2	0	0	2	0	0	0	0	0	0	0	0	0	0	0	2
0900-1000	0	0	0	0	0	0	0	0	0	0	0	0	0	0	0	0	0	0	0	0	0	0
1500-1600	0	2	0	0	2	0	0	0	0	0	0	0	0	0	0	0	0	0	0	0	0	2
1600-1700	0	3	0	0	3	0	0	0	0	0	1	0	1	0	0	0	0	0	0	0	0	4
1700-1800	0	3	0	0	3	0	1	0	0	1	0	0	0	0	0	0	0	0	0	0	0	4
<b>Totals</b>	<b>0</b>	<b>8</b>	<b>0</b>	<b>0</b>	<b>8</b>	<b>0</b>	<b>3</b>	<b>0</b>	<b>3</b>	<b>1</b>	<b>1</b>	<b>0</b>	<b>2</b>	<b>0</b>	<b>0</b>	<b>0</b>	<b>0</b>	<b>0</b>	<b>0</b>	<b>0</b>	<b>0</b>	<b>13</b>

**Comments:**  
OC Transpo, Para Transpo buses and school buses comprise 41.89% of the heavy vehicle traffic. There were 4 vehicle/vehicle conflicts involving northbound left-turning vehicles from Blackburn Avenue & eastbound through vehicles on Laurier Avenue (E) at: 1646h, 1707h, 1729h & 1749h. The pedestrian crossings totals include 2 pedestrians with accessibility issues using either a cane or walker.



## Turning Movement Count Pedestrian Crossings Summary and Flow Diagram



### Blackburn Avenue & Laurier Avenue East Ottawa, ON

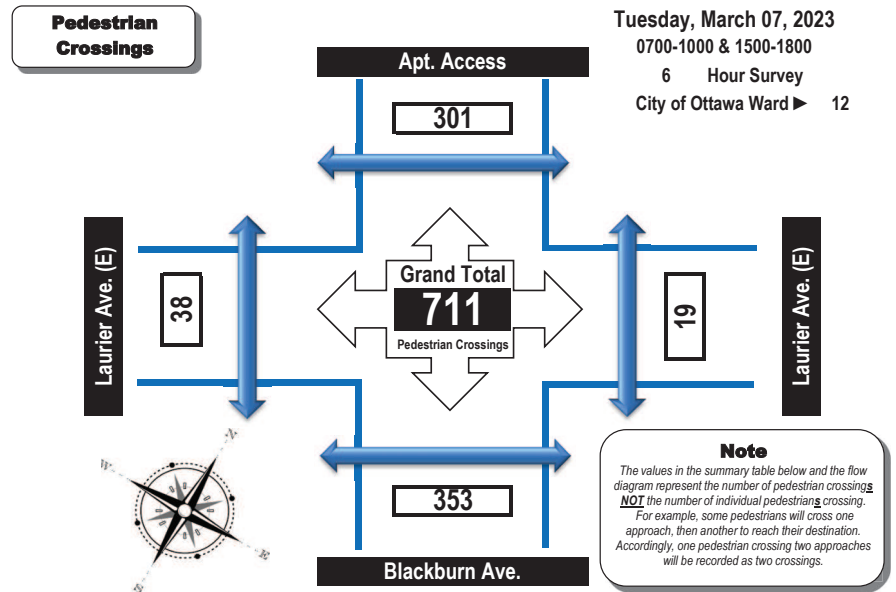

Time Period	West Side Crossing Laurier Ave. (E)	East Side Crossing Laurier Ave. (E)	Street Total	South Side Crossing Blackburn Ave.	North Side Crossing Apt. Access	Street Total	Grand Total
0700-0800	6	1	7	26	37	63	70
0800-0900	8	4	12	65	40	105	117
0900-1000	4	5	9	42	48	90	99
1500-1600	10	2	12	66	59	125	137
1600-1700	6	3	9	61	57	118	127
1700-1800	4	4	8	93	60	153	161
<b>Totals</b>	<b>38</b>	<b>19</b>	<b>57</b>	<b>353</b>	<b>301</b>	<b>654</b>	<b>711</b>

**Comments:**  
OC Transpo, Para Transpo buses and school buses comprise 41.89% of the heavy vehicle traffic. There were 4 vehicle/vehicle conflicts involving northbound left-turning vehicles from Blackburn Avenue & eastbound through vehicles on Laurier Avenue (E) at: 1646h, 1707h, 1729h & 1749h. The pedestrian crossings totals include 2 pedestrians with accessibility issues using either a cane or walker.



## Turning Movement Count Summary Report Including AM and PM Peak Hours All Vehicles Except Bicycles



### Blackburn Avenue & Osgoode Street Ottawa, ON

Survey Date: Tuesday, March 07, 2023 Start Time: 0700 AADT Factor: 1.0  
Weather AM: Mostly Cloudy -8° C Survey Duration: 6 Hrs. Survey Hours: 0700-1000 & 1500-1800  
Weather PM: Overcast -4° C Surveyor(s): T. Carmody

Time Period	Osgoode St. Eastbound				Osgoode St. Westbound				Blackburn Ave. Northbound				Blackburn Ave. Southbound				Street Total	Grand Total					
	LT	ST	RT	UT	LT	ST	RT	UT	LT	ST	RT	UT	LT	ST	RT	UT							
	E/B Tot				W/B Tot				N/B Tot				S/B Tot										
0700-0800	0	11	1	0	12	2	13	1	1	17	29	4	10	1	0	15	1	4	1	0	6	21	50
0800-0900	1	27	5	0	33	4	19	2	0	25	58	2	12	6	1	21	2	7	4	0	13	34	92
0900-1000	2	16	6	0	24	4	12	1	0	17	41	3	13	1	1	18	4	8	1	0	13	31	72
1500-1600	1	13	4	0	18	3	24	3	1	31	49	2	9	6	0	17	7	14	2	0	23	40	89
1600-1700	3	16	4	0	23	4	6	2	0	12	35	4	8	3	0	15	1	18	1	0	20	35	70
1700-1800	4	16	2	0	22	2	17	1	1	21	43	1	18	2	0	21	2	15	6	0	23	44	87
<b>Totals</b>	<b>11</b>	<b>99</b>	<b>22</b>	<b>0</b>	<b>132</b>	<b>19</b>	<b>91</b>	<b>10</b>	<b>3</b>	<b>123</b>	<b>255</b>	<b>16</b>	<b>70</b>	<b>19</b>	<b>2</b>	<b>107</b>	<b>17</b>	<b>66</b>	<b>15</b>	<b>0</b>	<b>98</b>	<b>205</b>	<b>460</b>

**Equivalent 12 & 24-hour Vehicle Volumes Including the Annual Average Daily Traffic (AADT) Factor  
Applicable to the Day and Month of the Turning Movement Count**

**Expansion factors are applied exclusively to standard weekday 8-hour turning movement counts conducted during the hours of 0700h - 1000h, 1130h - 1330h and 1500h - 1800h**

Equivalent 12-hour vehicle volumes. These volumes are calculated by multiplying the 8-hour totals by the 8 → 12 expansion factor of 1.39																			
Equ. 12 Hr	n/a	n/a	n/a	n/a	n/a	n/a	n/a	n/a	n/a	n/a	n/a	n/a	n/a	n/a	n/a	n/a	n/a	n/a	n/a
Average daily 12-hour vehicle volumes. These volumes are calculated by multiplying the equivalent 12-hour totals by the AADT factor of: 1.0																			
AADT 12-hr	n/a	n/a	n/a	n/a	n/a	n/a	n/a	n/a	n/a	n/a	n/a	n/a	n/a	n/a	n/a	n/a	n/a	n/a	n/a
24-Hour AADT. These volumes are calculated by multiplying the average daily 12-hour vehicle volumes by the 12 → 24 expansion factor of 1.31																			
AADT 24 Hr	n/a	n/a	n/a	n/a	n/a	n/a	n/a	n/a	n/a	n/a	n/a	n/a	n/a	n/a	n/a	n/a	n/a	n/a	n/a

### AADT and expansion factors provided by the City of Ottawa

AM Peak Hour Factor → 0.78											Highest Hourly Vehicle Volume Between 0700h & 1000h												
AM Peak Hr	LT	ST	RT	UT	Total	LT	ST	RT	UT	Total	Str. Tot.	LT	ST	RT	UT	Total	LT	ST	RT	UT	Total	Str. Tot.	Gr. Tot.
0815-0915	1	26	7	0	34	6	18	1	0	25	59	2	13	6	1	22	2	8	3	0	13	35	94

PM Peak Hour Factor → 0.84											Highest Hourly Vehicle Volume Between 1500h & 1800h												
PM Peak Hr	LT	ST	RT	UT	Total	LT	ST	RT	UT	Total	Str. Tot.	LT	ST	RT	UT	Total	LT	ST	RT	UT	Total	Str. Tot.	Gr. Tot.
1515-1615	2	20	2	0	24	3	23	2	1	29	53	4	9	3	0	16	6	13	3	0	22	38	91

**Comments:**  
School buses (2) comprise 15.38% of the heavy vehicle traffic. Many drivers on Osgoode Street either slow down or stop at Blackburn Avenue as if this is an all-way stop controlled intersection.

**Notes:**  
1. Includes all vehicle types except bicycles, electric bicycles, and electric scooters.  
2. When expansion and AADT factors are applied, the results will differ slightly due to rounding.



### Turning Movement Count Summary, AM and PM Peak Hour Flow Diagrams All Vehicles Except Bicycles



#### Blackburn Avenue & Osgoode Street Ottawa, ON

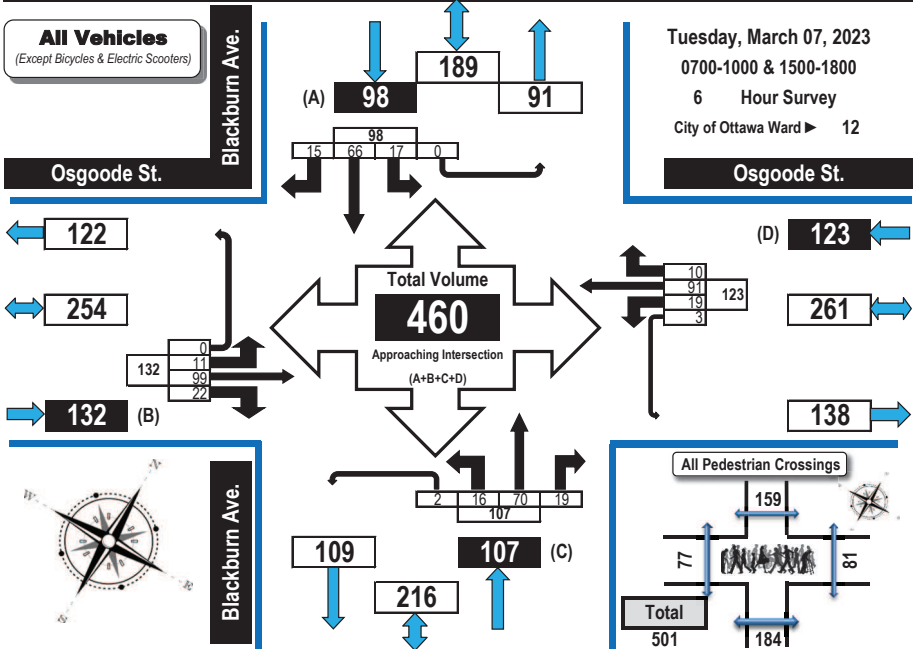

#### AM Peak Hour Flow Diagram PM Peak Hour Flow Diagram

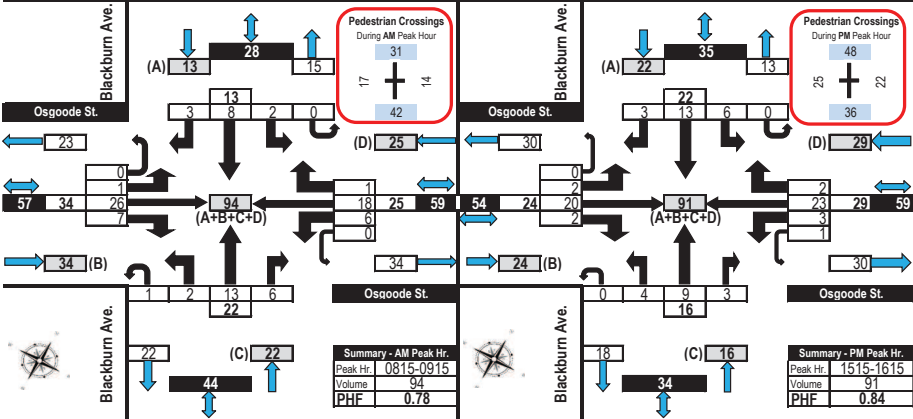

Printed on: 3/9/2023

Prepared by: thetrafficspecialist@gmail.com

Flow Diagrams: AM PM Peak



### Turning Movement Count Heavy Vehicle Summary (FHWA Class 4-13) Flow Diagram



#### Blackburn Avenue & Osgoode Street Ottawa, ON

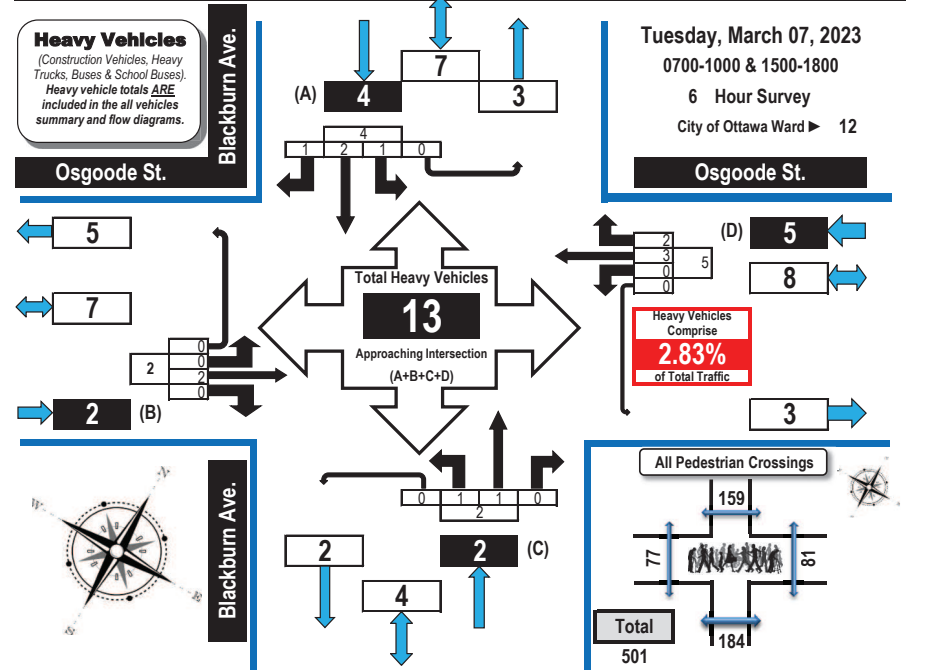

Time Period	Osgoode St. Eastbound				Osgoode St. Westbound				Blackburn Ave. Northbound				Blackburn Ave. Southbound				GR Tot
	LT	ST	RT	UT	LT	ST	RT	UT	LT	ST	RT	UT	LT	ST	RT	UT	

0700-0800	0	1	0	0	1	0	1	0	0	1	0	0	0	0	0	0	1	0	1	3
0800-0900	0	0	0	0	0	0	0	0	0	0	1	0	0	0	0	0	0	0	0	1
0900-1000	0	0	0	0	0	0	1	1	0	2	1	0	0	0	0	1	1	2	0	3
1500-1600	0	1	0	0	1	0	0	1	0	1	0	0	0	0	0	0	0	0	0	2
1600-1700	0	0	0	0	0	0	0	0	0	0	0	0	0	0	0	0	0	0	0	0
1700-1800	0	0	0	0	0	0	1	0	0	1	0	0	0	0	0	0	0	0	0	1
<b>Totals</b>	<b>0</b>	<b>2</b>	<b>0</b>	<b>0</b>	<b>2</b>	<b>0</b>	<b>3</b>	<b>2</b>	<b>0</b>	<b>5</b>	<b>1</b>	<b>1</b>	<b>0</b>	<b>0</b>	<b>2</b>	<b>1</b>	<b>2</b>	<b>1</b>	<b>0</b>	<b>13</b>

**Comments:**

School buses (2) comprise 15.38% of the heavy vehicle traffic. Many drivers on Osgoode Street either slow down or stop at Blackburn Avenue as if this is an all-way stop controlled intersection.

Printed on: 3/9/2023

Prepared by: thetrafficspecialist@gmail.com

Summary: Heavy Vehicles



### Turning Movement Count All Buses Summary (FHWA Class 4 ONLY) Flow Diagram



#### Blackburn Avenue & Osgoode Street Ottawa, ON

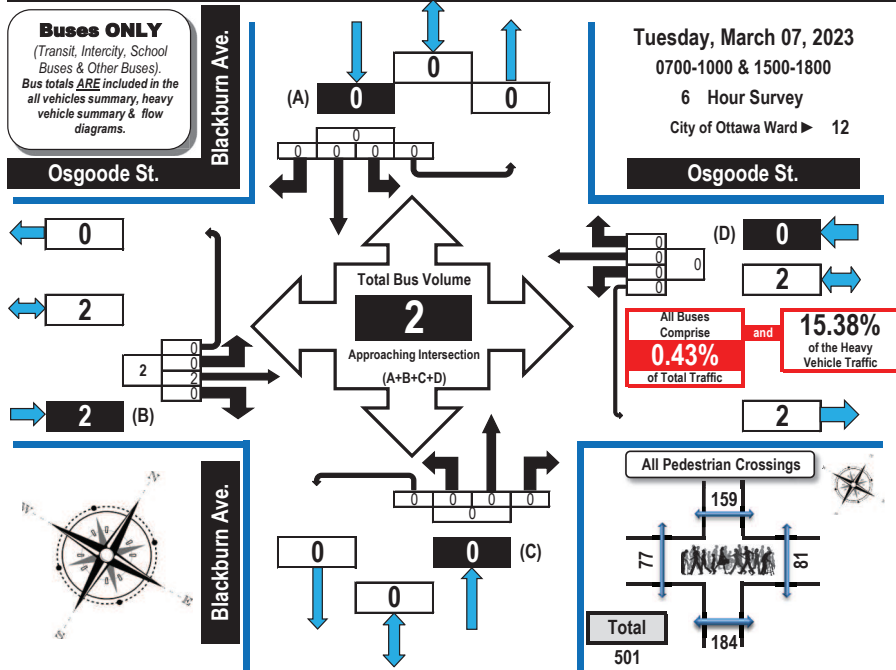

Time Period	Osgoode St. Eastbound				Osgoode St. Westbound				Blackburn Ave. Northbound				Blackburn Ave. Southbound				GR Tot					
	LT	ST	RT	UT	EB Tot	LT	ST	RT	UT	WB Tot	LT	ST	RT	UT	NB Tot	LT		ST	RT	UT	SB Tot	
0700-0800	0	1	0	0	1	0	0	0	0	0	0	0	0	0	0	0	0	0	0	0	0	1
0800-0900	0	0	0	0	0	0	0	0	0	0	0	0	0	0	0	0	0	0	0	0	0	0
0900-1000	0	0	0	0	0	0	0	0	0	0	0	0	0	0	0	0	0	0	0	0	0	0
1500-1600	0	1	0	0	1	0	0	0	0	0	0	0	0	0	0	0	0	0	0	0	0	1
1600-1700	0	0	0	0	0	0	0	0	0	0	0	0	0	0	0	0	0	0	0	0	0	0
1700-1800	0	0	0	0	0	0	0	0	0	0	0	0	0	0	0	0	0	0	0	0	0	0
<b>Totals</b>	<b>0</b>	<b>2</b>	<b>0</b>	<b>0</b>	<b>2</b>	<b>0</b>	<b>0</b>	<b>0</b>	<b>0</b>	<b>0</b>	<b>0</b>	<b>0</b>	<b>0</b>	<b>0</b>	<b>0</b>	<b>0</b>	<b>0</b>	<b>0</b>	<b>0</b>	<b>0</b>	<b>0</b>	<b>2</b>

**Comments:**  
School buses (2) comprise 15.38% of the heavy vehicle traffic. Many drivers on Osgoode Street either slow down or stop at Blackburn Avenue as if this is an all-way stop controlled intersection.



### Turning Movement Count Bicycle Summary Flow Diagram



#### Blackburn Avenue & Osgoode Street Ottawa, ON

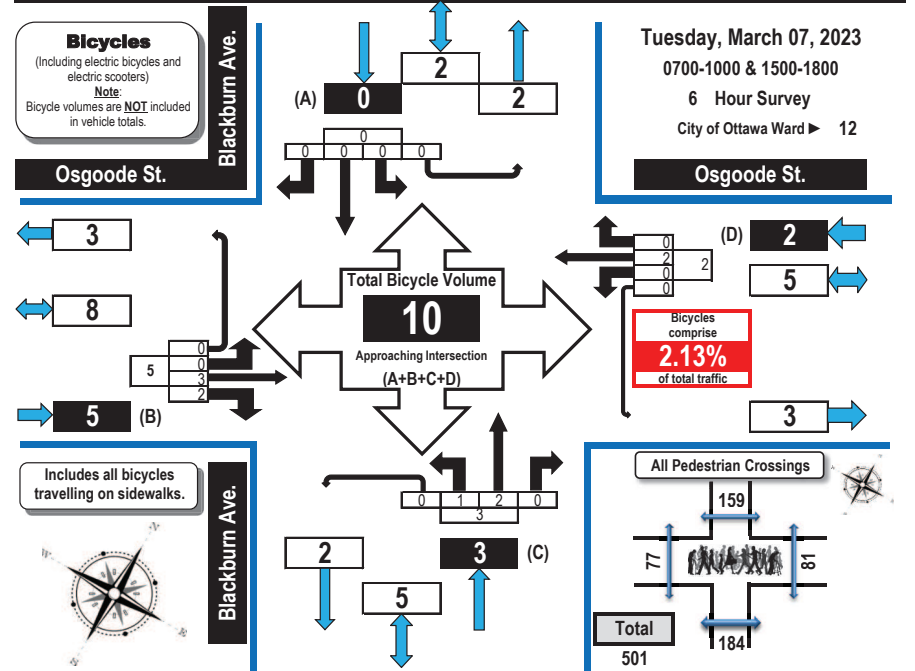

Time Period	Osgoode St. Eastbound				Osgoode St. Westbound				Blackburn Ave. Northbound				Blackburn Ave. Southbound				GR Tot					
	LT	ST	RT	UT	EB Tot	LT	ST	RT	UT	WB Tot	LT	ST	RT	UT	NB Tot	LT		ST	RT	UT	SB Tot	
0700-0800	0	0	1	0	1	0	0	0	0	0	0	1	0	0	1	0	0	0	0	0	0	2
0800-0900	0	2	0	0	2	0	1	0	0	1	0	0	0	0	0	0	0	0	0	0	0	3
0900-1000	0	0	0	0	0	0	0	0	0	0	0	0	0	0	0	0	0	0	0	0	0	0
1500-1600	0	1	0	0	1	0	0	0	0	0	1	0	0	0	1	0	0	0	0	0	0	2
1600-1700	0	0	1	0	1	0	1	0	0	1	0	1	0	0	1	0	0	0	0	0	0	3
1700-1800	0	0	0	0	0	0	0	0	0	0	0	0	0	0	0	0	0	0	0	0	0	0
<b>Totals</b>	<b>0</b>	<b>3</b>	<b>2</b>	<b>0</b>	<b>5</b>	<b>0</b>	<b>2</b>	<b>0</b>	<b>0</b>	<b>2</b>	<b>1</b>	<b>2</b>	<b>0</b>	<b>0</b>	<b>3</b>	<b>0</b>	<b>0</b>	<b>0</b>	<b>0</b>	<b>0</b>	<b>0</b>	<b>10</b>

**Comments:**  
School buses (2) comprise 15.38% of the heavy vehicle traffic. Many drivers on Osgoode Street either slow down or stop at Blackburn Avenue as if this is an all-way stop controlled intersection.



## Turning Movement Count Pedestrian Crossings Summary and Flow Diagram



**Blackburn Avenue & Osgoode Street** Ottawa, ON

**Pedestrian  
Crossings**

**Tuesday, March 07, 2023**  
0700-1000 & 1500-1800  
6 Hour Survey  
City of Ottawa Ward ► 12

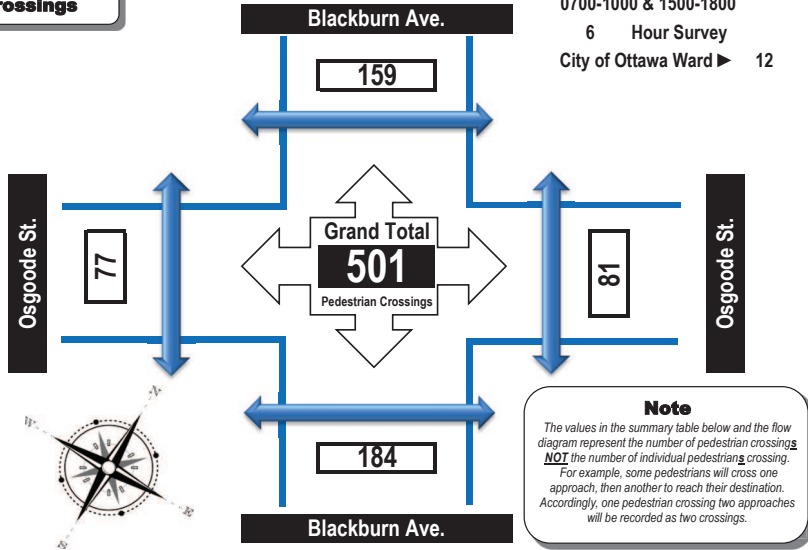

**Note**  
The values in the summary table below and the flow diagram represent the number of pedestrian crossings, **NOT** the number of individual pedestrian crossings. For example, some pedestrians will cross one approach, then another to reach their destination. Accordingly, one pedestrian crossing two approaches will be recorded as two crossings.

Time Period	West Side Crossing Osgoode St.	East Side Crossing Osgoode St.	Street Total	South Side Crossing Blackburn Ave.	North Side Crossing Blackburn Ave.	Street Total	Grand Total
0700-0800	7	3	10	11	8	19	29
0800-0900	15	16	31	44	31	75	106
0900-1000	12	6	18	32	15	47	65
1500-1600	23	22	45	27	39	66	111
1600-1700	6	21	27	29	31	60	87
1700-1800	14	13	27	41	35	76	103
<b>Totals</b>	<b>77</b>	<b>81</b>	<b>158</b>	<b>184</b>	<b>159</b>	<b>343</b>	<b>501</b>

**Comments:**

School buses (2) comprise 15.38% of the heavy vehicle traffic. Many drivers on Osgoode Street either slow down or stop at Blackburn Avenue as if this is an all-way stop controlled intersection.



# Appendix C

Synchro Intersection Worksheets – Existing Conditions

Lanes, Volumes, Timings  
1: Nelson & Laurier

Existing AM Peak Hour  
315 Chapel Street

	↖	→	↗	←	↖	↑	↗	↓
Lane Group	EBL	EBT	WBL	WBT	NBL	NBT	SBL	SBT
Lane Configurations		↕		↕		↕		↕
Traffic Volume (vph)	38	202	27	278	6	14	6	35
Future Volume (vph)	38	202	27	278	6	14	6	35
Lane Group Flow (vph)	0	286	0	358	0	44	0	63
Turn Type	Perm	NA	Perm	NA	Perm	NA	Perm	NA
Protected Phases		2		6		8		4
Permitted Phases	2		6		8		4	
Detector Phase	2	2	6	6	8	8	4	4
Switch Phase								
Minimum Initial (s)	10.0	10.0	10.0	10.0	10.0	10.0	10.0	10.0
Minimum Split (s)	17.0	17.0	17.0	17.0	20.4	20.4	20.4	20.4
Total Split (s)	49.0	49.0	49.0	49.0	21.0	21.0	21.0	21.0
Total Split (%)	70.0%	70.0%	70.0%	70.0%	30.0%	30.0%	30.0%	30.0%
Maximum Green (s)	44.0	44.0	44.0	44.0	15.6	15.6	15.6	15.6
Yellow Time (s)	3.3	3.3	3.3	3.3	3.3	3.3	3.3	3.3
All-Red Time (s)	1.7	1.7	1.7	1.7	2.1	2.1	2.1	2.1
Lost Time Adjust (s)		0.0		0.0		0.0		0.0
Total Lost Time (s)		5.0		5.0		5.4		5.4
Lead/Lag								
Lead-Lag Optimize?								
Vehicle Extension (s)	3.0	3.0	3.0	3.0	3.0	3.0	3.0	3.0
Recall Mode	C-Max	C-Max	C-Max	C-Max	Max	Max	Max	Max
Walk Time (s)	7.0	7.0	7.0	7.0	7.0	7.0	7.0	7.0
Flash Dont Walk (s)	5.0	5.0	5.0	5.0	8.0	8.0	8.0	8.0
Pedestrian Calls (#/hr)	209	209	221	221	48	48	103	103
Act Effct Green (s)		44.0		44.0		15.6		15.6
Actuated g/C Ratio		0.63		0.63		0.22		0.22
v/c Ratio		0.32		0.37		0.13		0.18
Control Delay		6.9		3.4		15.3		18.9
Queue Delay		0.0		0.3		0.0		0.0
Total Delay		6.9		3.7		15.3		18.9
LOS		A		A		B		B
Approach Delay		6.9		3.7		15.3		18.9
Approach LOS		A		A		B		B
Queue Length 50th (m)		14.4		12.1		2.4		4.9
Queue Length 95th (m)		25.7		3.2		9.7		13.8
Internal Link Dist (m)		128.9		72.2		182.0		96.0
Turn Bay Length (m)								
Base Capacity (vph)		907		964		332		349
Starvation Cap Reductn		0		191		0		0
Spillback Cap Reductn		0		0		0		0
Storage Cap Reductn		0		0		0		0
Reduced v/c Ratio		0.32		0.46		0.13		0.18

**Intersection Summary**  
 Cycle Length: 70  
 Actuated Cycle Length: 70  
 Offset: 0 (0%), Referenced to phase 2:EBTL and 6:WBT, Start of Green  
 Natural Cycle: 40

Lanes, Volumes, Timings  
1: Nelson & Laurier

Existing AM Peak Hour  
315 Chapel Street

Control Type: Actuated-Coordinated  
 Maximum v/c Ratio: 0.37  
 Intersection Signal Delay: 6.9  
 Intersection LOS: A  
 Intersection Capacity Utilization 44.9%  
 ICU Level of Service A  
 Analysis Period (min) 15

Splits and Phases: 1: Nelson & Laurier



Lanes, Volumes, Timings  
2: Sweetland & Laurier

Existing AM Peak Hour  
315 Chapel Street

Lane Group	EBT	WBL	WBT	NBL
Lane Configurations	↔	↔	↔	↔
Traffic Volume (vph)	216	25	311	10
Future Volume (vph)	216	25	311	10
Lane Group Flow (vph)	247	0	374	35
Turn Type	NA	Perm	NA	Prot
Protected Phases	2		6	8
Permitted Phases		6		
Detector Phase	2	6	6	8
Switch Phase				
Minimum Initial (s)	10.0	5.0	5.0	5.0
Minimum Split (s)	27.2	23.2	23.2	17.1
Total Split (s)	50.0	50.0	50.0	20.0
Total Split (%)	71.4%	71.4%	71.4%	28.6%
Maximum Green (s)	44.8	44.8	44.8	14.9
Yellow Time (s)	3.3	3.3	3.3	3.3
All-Red Time (s)	1.9	1.9	1.9	1.8
Lost Time Adjust (s)	0.0		0.0	0.0
Total Lost Time (s)	5.2		5.2	5.1
Lead/Lag				
Lead-Lag Optimize?				
Vehicle Extension (s)	3.0	3.0	3.0	3.0
Recall Mode	C-Max	C-Max	C-Max	None
Walk Time (s)	11.0			7.0
Flash Dont Walk (s)	5.0			5.0
Pedestrian Calls (#/hr)	143			28
Act Effct Green (s)	57.8		57.8	8.2
Actuated g/C Ratio	0.83		0.83	0.12
v/c Ratio	0.18		0.28	0.18
Control Delay	2.4		2.7	16.4
Queue Delay	0.0		0.0	0.0
Total Delay	2.4		2.7	16.4
LOS	A		A	B
Approach Delay	2.4		2.7	16.4
Approach LOS	A		A	B
Queue Length 50th (m)	5.7		7.8	1.4
Queue Length 95th (m)	12.3		16.9	8.2
Internal Link Dist (m)	72.2		165.0	182.9
Turn Bay Length (m)				
Base Capacity (vph)	1409		1339	327
Starvation Cap Reductn	0		0	0
Spillback Cap Reductn	0		0	0
Storage Cap Reductn	0		0	0
Reduced v/c Ratio	0.18		0.28	0.11

Intersection Summary

Cycle Length: 70  
Actuated Cycle Length: 70  
Offset: 64 (91%), Referenced to phase 2:EBT and 6:WBTL, Start of Green  
Natural Cycle: 45

Lanes, Volumes, Timings  
2: Sweetland & Laurier

Existing AM Peak Hour  
315 Chapel Street

Control Type: Actuated-Coordinated	
Maximum v/c Ratio: 0.28	
Intersection Signal Delay: 3.3	Intersection LOS: A
Intersection Capacity Utilization 52.7%	ICU Level of Service A
Analysis Period (min) 15	

Splits and Phases: 2: Sweetland & Laurier



Lanes, Volumes, Timings  
3: Chapel & Laurier

Existing AM Peak Hour  
315 Chapel Street

	↖	→	↗	←	↖	↑	↗	↓
Lane Group	EBL	EBT	WBL	WBT	NBL	NBT	SBL	SBT
Lane Configurations		↕		↕		↕		↕
Traffic Volume (vph)	23	198	6	257	6	17	5	16
Future Volume (vph)	23	198	6	257	6	17	5	16
Lane Group Flow (vph)	0	256	0	306	0	37	0	47
Turn Type	Perm	NA	Perm	NA	Perm	NA	Perm	NA
Protected Phases		2		6		8		4
Permitted Phases	2		6		8		4	
Detector Phase	2	2	6	6	8	8	4	4
Switch Phase								
Minimum Initial (s)	10.0	10.0	10.0	10.0	10.0	10.0	10.0	10.0
Minimum Split (s)	26.1	26.1	26.1	26.1	23.3	23.3	23.3	23.3
Total Split (s)	45.0	45.0	45.0	45.0	25.0	25.0	25.0	25.0
Total Split (%)	64.3%	64.3%	64.3%	64.3%	35.7%	35.7%	35.7%	35.7%
Maximum Green (s)	39.9	39.9	39.9	39.9	19.7	19.7	19.7	19.7
Yellow Time (s)	3.3	3.3	3.3	3.3	3.3	3.3	3.3	3.3
All-Red Time (s)	1.8	1.8	1.8	1.8	2.0	2.0	2.0	2.0
Lost Time Adjust (s)		0.0		0.0		0.0		0.0
Total Lost Time (s)		5.1		5.1		5.3		5.3
Lead/Lag								
Lead-Lag Optimize?								
Vehicle Extension (s)	3.0	3.0	3.0	3.0	3.0	3.0	3.0	3.0
Recall Mode	C-Max	C-Max	C-Max	C-Max	Max	Max	Max	Max
Walk Time (s)	10.0	10.0	10.0	10.0	7.0	7.0	7.0	7.0
Flash Dont Walk (s)	5.0	5.0	5.0	5.0	5.0	5.0	5.0	5.0
Pedestrian Calls (#/hr)	5	5	9	9	5	5	6	6
Act Effct Green (s)		39.9		39.9		19.7		19.7
Actuated g/C Ratio		0.57		0.57		0.28		0.28
v/c Ratio		0.28		0.32		0.08		0.11
Control Delay		6.6		8.9		15.1		12.6
Queue Delay		0.0		0.0		0.0		0.0
Total Delay		6.6		8.9		15.1		12.6
LOS		A		A		B		B
Approach Delay		6.6		8.9		15.1		12.6
Approach LOS		A		A		B		B
Queue Length 50th (m)		9.8		18.7		2.5		2.3
Queue Length 95th (m)		16.3		31.9		8.6		9.2
Internal Link Dist (m)		165.0		51.8		176.5		87.4
Turn Bay Length (m)								
Base Capacity (vph)		907		953		446		438
Starvation Cap Reductn		0		0		0		0
Spillback Cap Reductn		0		0		0		0
Storage Cap Reductn		0		0		0		0
Reduced v/c Ratio		0.28		0.32		0.08		0.11
<b>Intersection Summary</b>								
Cycle Length: 70								
Actuated Cycle Length: 70								
Offset: 65 (93%), Referenced to phase 2:EBTL and 6:WBTL, Start of Green								
Natural Cycle: 50								

Lanes, Volumes, Timings  
3: Chapel & Laurier

Existing AM Peak Hour  
315 Chapel Street

Control Type: Actuated-Coordinated  
Maximum v/c Ratio: 0.32  
Intersection Signal Delay: 8.6  
Intersection LOS: A  
Intersection Capacity Utilization 43.1%  
ICU Level of Service A  
Analysis Period (min) 15

Splits and Phases: 3: Chapel & Laurier

HCM 2010 TWSC  
4: Blackburn/Private Access & Laurier

Existing AM Peak Hour  
315 Chapel Street

Intersection												
Int Delay, s/veh	0.8											
Movement	EBL	EBT	EBR	WBL	WBT	WBR	NBL	NBT	NBR	SBL	SBT	SBR
Lane Configurations	↕			↕			↕			↕		
Traffic Vol, veh/h	5	198	10	8	266	1	6	1	9	5	0	3
Future Vol, veh/h	5	198	10	8	266	1	6	1	9	5	0	3
Conflicting Peds, #/hr	40	0	58	58	0	40	7	0	3	3	0	7
Sign Control	Free	Free	Free	Free	Free	Free	Stop	Stop	Stop	Stop	Stop	Stop
RT Channelized	-	-	None	-	-	None	-	-	None	-	-	None
Storage Length	-	-	-	-	-	-	-	-	-	-	-	-
Veh in Median Storage, #	-	0	-	-	0	-	-	0	-	-	0	-
Grade, %	-	0	-	-	0	-	-	0	-	-	0	-
Peak Hour Factor	90	90	90	90	90	90	90	90	90	90	90	90
Heavy Vehicles, %	2	3	2	2	2	2	17	2	2	2	2	2
Mvmt Flow	6	220	11	9	296	1	7	1	10	6	0	3

Major/Minor	Major1		Major2		Minor1		Minor2					
Conflicting Flow All	337	0	0	289	0	0	619	651	287	601	656	344
Stage 1	-	-	-	-	-	-	296	296	-	355	355	-
Stage 2	-	-	-	-	-	-	323	355	-	246	301	-
Critical Hdwy	4.12	-	-	4.12	-	-	7.27	6.52	6.22	7.12	6.52	6.22
Critical Hdwy Stg 1	-	-	-	-	-	-	6.27	5.52	-	6.12	5.52	-
Critical Hdwy Stg 2	-	-	-	-	-	-	6.27	5.52	-	6.12	5.52	-
Follow-up Hdwy	2,218	-	-	2,218	-	-	3,653	4,018	3,318	3,518	4,018	3,318
Pot Cap-1 Maneuver	1222	-	-	1273	-	-	380	388	752	412	385	699
Stage 1	-	-	-	-	-	-	681	668	-	662	630	-
Stage 2	-	-	-	-	-	-	659	630	-	758	665	-
Platoon blocked, %	-	-	-	-	-	-	-	-	-	-	-	-
Mov Cap-1 Maneuver	1184	-	-	1216	-	-	355	354	716	387	351	674
Mov Cap-2 Maneuver	-	-	-	-	-	-	355	354	-	387	351	-
Stage 1	-	-	-	-	-	-	646	634	-	638	605	-
Stage 2	-	-	-	-	-	-	646	605	-	740	631	-

Approach	EB	WB	NB	SB
HCM Control Delay, s	0.2	0.2	12.5	13
HCM LOS			B	B

Minor Lane/Major Mvmt	NBLn1	EBL	EBT	EBR	WBL	WBT	WBR	SBLn1
Capacity (veh/h)	495	1184	-	-	1216	-	-	461
HCM Lane V/C Ratio	0.036	0.005	-	-	0.007	-	-	0.019
HCM Control Delay (s)	12.5	8.1	0	-	8	0	-	13
HCM Lane LOS	B	A	A	-	A	A	-	B
HCM 95th %tile Q(veh)	0.1	0	-	-	0	-	-	0.1

HCM 2010 TWSC  
5: Blackburn & Osgoode

Existing AM Peak Hour  
315 Chapel Street

Intersection												
Int Delay, s/veh	4.2											
Movement	EBL	EBT	EBR	WBL	WBT	WBR	NBL	NBT	NBR	SBL	SBT	SBR
Lane Configurations	↕			↕			↕			↕		
Traffic Vol, veh/h	1	26	7	6	18	1	3	13	6	2	8	3
Future Vol, veh/h	1	26	7	6	18	1	3	13	6	2	8	3
Conflicting Peds, #/hr	31	0	42	42	0	31	17	0	14	14	0	17
Sign Control	Free	Free	Free	Free	Free	Free	Stop	Stop	Stop	Stop	Stop	Stop
RT Channelized	-	-	None	-	-	None	-	-	None	-	-	None
Storage Length	-	-	-	-	-	-	-	-	-	-	-	-
Veh in Median Storage, #	-	0	-	-	0	-	-	0	-	-	0	-
Grade, %	-	0	-	-	0	-	-	0	-	-	0	-
Peak Hour Factor	90	90	90	90	90	90	90	90	90	90	90	90
Heavy Vehicles, %	2	2	2	2	2	2	2	2	8	2	2	2
Mvmt Flow	1	29	8	7	20	1	3	14	7	2	9	3

Major/Minor	Major1		Major2		Minor1		Minor2					
Conflicting Flow All	52	0	0	79	0	0	135	143	89	126	147	69
Stage 1	-	-	-	-	-	-	77	77	-	66	66	-
Stage 2	-	-	-	-	-	-	58	66	-	60	81	-
Critical Hdwy	4.12	-	-	4.12	-	-	7.12	6.58	6.22	7.12	6.52	6.22
Critical Hdwy Stg 1	-	-	-	-	-	-	6.12	5.58	-	6.12	5.52	-
Critical Hdwy Stg 2	-	-	-	-	-	-	6.12	5.58	-	6.12	5.52	-
Follow-up Hdwy	2,218	-	-	2,218	-	-	3,518	4,072	3,318	3,518	4,018	3,318
Pot Cap-1 Maneuver	1554	-	-	1519	-	-	836	737	969	848	744	994
Stage 1	-	-	-	-	-	-	932	819	-	945	840	-
Stage 2	-	-	-	-	-	-	954	828	-	951	828	-
Platoon blocked, %	-	-	-	-	-	-	-	-	-	-	-	-
Mov Cap-1 Maneuver	1517	-	-	1469	-	-	784	691	927	796	698	957
Mov Cap-2 Maneuver	-	-	-	-	-	-	784	691	-	796	698	-
Stage 1	-	-	-	-	-	-	900	791	-	921	816	-
Stage 2	-	-	-	-	-	-	923	804	-	916	800	-

Approach	EB	WB	NB	SB
HCM Control Delay, s	0.2	1.8	9.9	9.8
HCM LOS			A	A

Minor Lane/Major Mvmt	NBLn1	EBL	EBT	EBR	WBL	WBT	WBR	SBLn1
Capacity (veh/h)	756	1517	-	-	1469	-	-	760
HCM Lane V/C Ratio	0.032	0.001	-	-	0.005	-	-	0.019
HCM Control Delay (s)	9.9	7.4	0	-	7.5	0	-	9.8
HCM Lane LOS	A	A	A	-	A	A	-	A
HCM 95th %tile Q(veh)	0.1	0	-	-	0	-	-	0.1

Lanes, Volumes, Timings  
1: Nelson & Laurier

Existing PM Peak Hour  
315 Chapel Street

Lane Group	EBL	EBT	EBR	WBL	WBT	WBR	NBL	NBT	NBR	SBL	SBT	SBR
Lane Configurations		↔			↔			↔			↔	
Traffic Volume (vph)	44	368	11	14	189	23	16	46	25	3	20	13
Future Volume (vph)	44	368	11	14	189	23	16	46	25	3	20	13
Satd. Flow (prot)	0	1706	0	0	1583	0	0	1536	0	0	1382	0
Fit Permitted		0.948			0.967			0.948			0.982	
Satd. Flow (perm)	0	1558	0	0	1513	0	0	1380	0	0	1342	0
Satd. Flow (RTOR)		3			15			25			14	
Lane Group Flow (vph)	0	470	0	0	252	0	0	97	0	0	39	0
Turn Type	Perm	NA		Perm	NA		Perm	NA		Perm	NA	
Protected Phases		2			6			8			4	
Permitted Phases	2			6			8			4		
Detector Phase	2	2		6	6		8	8		4	4	
Switch Phase												
Minimum Initial (s)	10.0	10.0		10.0	10.0		10.0	10.0		10.0	10.0	
Minimum Split (s)	17.0	17.0		17.0	17.0		20.4	20.4		20.4	20.4	
Total Split (s)	53.0	53.0		53.0	53.0		22.0	22.0		22.0	22.0	
Total Split (%)	70.7%	70.7%		70.7%	70.7%		29.3%	29.3%		29.3%	29.3%	
Yellow Time (s)	3.3	3.3		3.3	3.3		3.3	3.3		3.3	3.3	
All-Red Time (s)	1.7	1.7		1.7	1.7		2.1	2.1		2.1	2.1	
Lost Time Adjust (s)		0.0			0.0			0.0			0.0	
Total Lost Time (s)		5.0			5.0			5.4			5.4	
Lead/Lag												
Lead-Lag Optimize?												
Recall Mode	C-Max	C-Max		C-Max	C-Max		Max	Max		Max	Max	
Act Effct Green (s)		48.0			48.0			16.6			16.6	
Actuated g/C Ratio		0.64			0.64			0.22			0.22	
v/c Ratio		0.47			0.26			0.30			0.13	
Control Delay		8.8			4.1			21.6			18.3	
Queue Delay		0.0			0.3			0.0			0.0	
Total Delay		8.8			4.4			21.6			18.3	
LOS		A			A			C			B	
Approach Delay		8.8			4.4			21.6			18.3	
Approach LOS		A			A			C			B	
Queue Length 50th (m)		29.6			2.5			8.4			2.8	
Queue Length 95th (m)		48.5			9.4			20.5			10.0	
Internal Link Dist (m)		128.9			72.2			182.0			96.0	
Turn Bay Length (m)												
Base Capacity (vph)		998			973			324			307	
Starvation Cap Reductn		0			311			0			0	
Spillback Cap Reductn		0			0			0			0	
Storage Cap Reductn		0			0			0			0	
Reduced v/c Ratio		0.47			0.38			0.30			0.13	

Intersection Summary	
Cycle Length:	75
Actuated Cycle Length:	75
Offset:	25 (33%), Referenced to phase 2:EBTL and 6:WBTL, Start of Green
Natural Cycle:	50
Control Type:	Actuated-Coordinated

Lanes, Volumes, Timings  
1: Nelson & Laurier

Existing PM Peak Hour  
315 Chapel Street

Maximum v/c Ratio: 0.47	Intersection Signal Delay: 9.4	Intersection LOS: A
Intersection Capacity Utilization 57.1%	ICU Level of Service B	
Analysis Period (min) 15		

Splits and Phases: 1: Nelson & Laurier

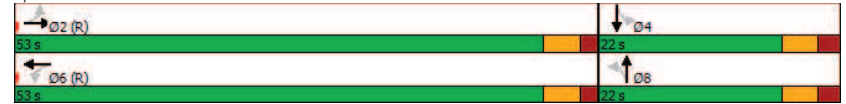

Lanes, Volumes, Timings  
2: Sweetland & Laurier

Existing PM Peak Hour  
315 Chapel Street

Lane Group	EBT	EBR	WBL	WBT	NBL	NBR
Lane Configurations	↔	↔	↔	↔	↔	↔
Traffic Volume (vph)	401	13	21	216	12	24
Future Volume (vph)	401	13	21	216	12	24
Satd. Flow (prot)	1709	0	0	1723	1433	0
Fit Permitted				0.952	0.984	
Satd. Flow (perm)	1709	0	0	1614	1388	0
Satd. Flow (RTOR)	4				27	
Lane Group Flow (vph)	460	0	0	263	40	0
Turn Type	NA		Perm	NA	Prot	
Protected Phases	2			6	8	
Permitted Phases			6			
Detector Phase	2		6	6	8	
Switch Phase						
Minimum Initial (s)	10.0		5.0	5.0	5.0	
Minimum Split (s)	27.2		23.2	23.2	17.1	
Total Split (s)	55.0		55.0	55.0	20.0	
Total Split (%)	73.3%		73.3%	73.3%	26.7%	
Yellow Time (s)	3.3		3.3	3.3	3.3	
All-Red Time (s)	1.9		1.9	1.9	1.8	
Lost Time Adjust (s)	0.0		0.0	0.0	0.0	
Total Lost Time (s)	5.2		5.2	5.2	5.1	
Lead/Lag						
Lead-Lag Optimize?						
Recall Mode	C-Max		C-Max	C-Max	None	
Act Effct Green (s)	62.8		62.8	62.8	8.2	
Actuated g/C Ratio	0.84		0.84	0.84	0.11	
v/c Ratio	0.32		0.19	0.19	0.22	
Control Delay	1.6		2.7	2.7	18.1	
Queue Delay	0.1		0.0	0.0	0.0	
Total Delay	1.7		2.7	2.7	18.1	
LOS	A		A	A	B	
Approach Delay	1.7		2.7	2.7	18.1	
Approach LOS	A		A	A	B	
Queue Length 50th (m)	6.1		6.3	6.3	1.8	
Queue Length 95th (m)	10.1		14.9	14.9	9.4	
Internal Link Dist (m)	72.2		165.0	165.0	182.9	
Turn Bay Length (m)						
Base Capacity (vph)	1432		1351	1351	306	
Starvation Cap Reductn	201		0	0	0	
Spillback Cap Reductn	0		0	0	0	
Storage Cap Reductn	0		0	0	0	
Reduced v/c Ratio	0.37		0.19	0.19	0.13	

Intersection Summary	
Cycle Length:	75
Actuated Cycle Length:	75
Offset:	27 (36%), Referenced to phase 2:EBT and 6:WBTL, Start of Green
Natural Cycle:	45
Control Type:	Actuated-Coordinated

Lanes, Volumes, Timings  
2: Sweetland & Laurier

Existing PM Peak Hour  
315 Chapel Street

Maximum v/c Ratio: 0.32	Intersection LOS: A
Intersection Signal Delay: 2.9	ICU Level of Service A
Intersection Capacity Utilization 47.1%	
Analysis Period (min) 15	

Splits and Phases: 2: Sweetland & Laurier

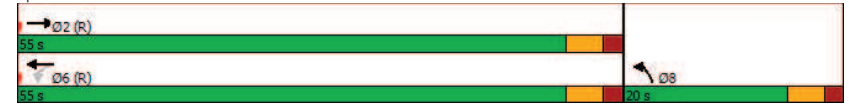

Lanes, Volumes, Timings  
3: Chapel & Laurier

Existing PM Peak Hour  
315 Chapel Street

Lane Group	EBL	EBT	EBR	WBL	WBT	WBR	NBL	NBT	NBR	SBL	SBT	SBR
Lane Configurations		↔			↔			↔			↔	
Traffic Volume (vph)	36	279	19	10	177	11	10	31	10	4	71	13
Future Volume (vph)	36	279	19	10	177	11	10	31	10	4	71	13
Satd. Flow (prot)	0	1713	0	0	1709	0	0	1664	0	0	1694	0
Fit Permitted		0.952			0.980			0.948			0.992	
Satd. Flow (perm)	0	1635	0	0	1676	0	0	1583	0	0	1682	0
Satd. Flow (RTOR)		7			7			11			11	
Lane Group Flow (vph)	0	371	0	0	220	0	0	56	0	0	97	0
Turn Type	Perm	NA		Perm	NA		Perm	NA		Perm	NA	
Protected Phases		2			6			8			4	
Permitted Phases	2			6			8			4		
Detector Phase	2	2		6	6		8	8		4	4	
Switch Phase												
Minimum Initial (s)	10.0	10.0		10.0	10.0		10.0	10.0		10.0	10.0	
Minimum Split (s)	26.1	26.1		26.1	26.1		23.3	23.3		23.3	23.3	
Total Split (s)	50.0	50.0		50.0	50.0		25.0	25.0		25.0	25.0	
Total Split (%)	66.7%	66.7%		66.7%	66.7%		33.3%	33.3%		33.3%	33.3%	
Yellow Time (s)	3.3	3.3		3.3	3.3		3.3	3.3		3.3	3.3	
All-Red Time (s)	1.8	1.8		1.8	1.8		2.0	2.0		2.0	2.0	
Lost Time Adjust (s)		0.0			0.0			0.0			0.0	
Total Lost Time (s)		5.1			5.1			5.3			5.3	
Lead/Lag												
Lead-Lag Optimize?												
Recall Mode	C-Max	C-Max		C-Max	C-Max		Max	Max		Max	Max	
Act Effct Green (s)		44.9			44.9			19.7			19.7	
Actuated g/C Ratio		0.60			0.60			0.26			0.26	
v/c Ratio		0.38			0.22			0.13			0.22	
Control Delay		5.0			7.4			18.9			20.7	
Queue Delay		0.0			0.0			0.0			0.0	
Total Delay		5.0			7.4			18.9			20.7	
LOS		A			A			B			C	
Approach Delay		5.0			7.4			18.9			20.7	
Approach LOS		A			A			B			C	
Queue Length 50th (m)		12.7			12.5			4.8			9.4	
Queue Length 95th (m)		12.2			22.0			13.1			20.6	
Internal Link Dist (m)		165.0			51.8			176.5			87.4	
Turn Bay Length (m)												
Base Capacity (vph)		981			1006			423			449	
Starvation Cap Reductn		0			0			0			0	
Spillback Cap Reductn		0			0			0			0	
Storage Cap Reductn		0			0			0			0	
Reduced v/c Ratio		0.38			0.22			0.13			0.22	

Intersection Summary	
Cycle Length:	75
Actuated Cycle Length:	75
Offset:	37 (49%), Referenced to phase 2:EBTL and 6:WBTL, Start of Green
Natural Cycle:	50
Control Type:	Actuated-Coordinated

Lanes, Volumes, Timings  
3: Chapel & Laurier

Existing PM Peak Hour  
315 Chapel Street

Maximum v/c Ratio: 0.38	Intersection LOS: A
Intersection Signal Delay: 8.8	ICU Level of Service A
Intersection Capacity Utilization 49.1%	
Analysis Period (min) 15	

Splits and Phases: 3: Chapel & Laurier





HCM 2010 TWSC  
4: Blackburn/Private Access & Laurier

Existing PM Peak Hour  
315 Chapel Street

Intersection												
Int Delay, s/veh	1											
Movement	EBL	EBT	EBR	WBL	WBT	WBR	NBL	NBT	NBR	SBL	SBT	SBR
Lane Configurations	↕			↕			↕			↕		
Traffic Vol, veh/h	7	276	10	13	183	3	10	1	5	3	1	5
Future Vol, veh/h	7	276	10	13	183	3	10	1	5	3	1	5
Conflicting Peds, #/hr	56	0	62	62	0	56	11	0	3	3	0	11
Sign Control	Free	Free	Free	Free	Free	Free	Stop	Stop	Stop	Stop	Stop	Stop
RT Channelized	-	-	None	-	-	None	-	-	None	-	-	None
Storage Length	-	-	-	-	-	-	-	-	-	-	-	-
Veh in Median Storage, #	-	0	-	-	0	-	-	0	-	-	0	-
Grade, %	-	0	-	-	0	-	-	0	-	-	0	-
Peak Hour Factor	90	90	90	90	90	90	90	90	90	90	90	90
Heavy Vehicles, %	2	2	2	2	2	2	2	2	2	2	2	2
Mvmt Flow	8	307	11	14	203	3	11	1	6	3	1	6

Major/Minor	Major1	Major2	Minor1	Minor2
Conflicting Flow All	262	0	0	380
Stage 1	-	-	-	-
Stage 2	-	-	-	-
Critical Hdwy	4.12	-	-	4.12
Critical Hdwy Stg 1	-	-	-	-
Critical Hdwy Stg 2	-	-	-	-
Follow-up Hdwy	2.218	-	-	2.218
Pot Cap-1 Maneuver	1302	-	-	1178
Stage 1	-	-	-	-
Stage 2	-	-	-	-
Platoon blocked, %	-	-	-	-
Mov Cap-1 Maneuver	1245	-	-	1121
Mov Cap-2 Maneuver	-	-	-	-
Stage 1	-	-	-	-
Stage 2	-	-	-	-

Approach	EB	WB	NB	SB
HCM Control Delay, s	0.2	0.5	14.2	12.4
HCM LOS			B	B

Minor Lane/Major Mvmt	NBLn1	EBL	EBT	EBR	WBL	WBT	WBR	SBLn1
Capacity (veh/h)	411	1245	-	-	1121	-	-	499
HCM Lane V/C Ratio	0.043	0.006	-	-	0.013	-	-	0.02
HCM Control Delay (s)	14.2	7.9	0	-	8.3	0	-	12.4
HCM Lane LOS	B	A	A	-	A	A	-	B
HCM 95th %tile Q(veh)	0.1	0	-	-	0	-	-	0.1

HCM 2010 TWSC  
5: Blackburn & Osgoode

Existing PM Peak Hour  
315 Chapel Street

Intersection												
Int Delay, s/veh	4.7											
Movement	EBL	EBT	EBR	WBL	WBT	WBR	NBL	NBT	NBR	SBL	SBT	SBR
Lane Configurations	↕			↕			↕			↕		
Traffic Vol, veh/h	2	20	2	4	23	2	4	9	3	6	13	3
Future Vol, veh/h	2	20	2	4	23	2	4	9	3	6	13	3
Conflicting Peds, #/hr	48	0	36	36	0	48	25	0	22	22	0	25
Sign Control	Free	Free	Free	Free	Free	Free	Stop	Stop	Stop	Stop	Stop	Stop
RT Channelized	-	-	None	-	-	None	-	-	None	-	-	None
Storage Length	-	-	-	-	-	-	-	-	-	-	-	-
Veh in Median Storage, #	-	0	-	-	0	-	-	0	-	-	0	-
Grade, %	-	0	-	-	0	-	-	0	-	-	0	-
Peak Hour Factor	90	90	90	90	90	90	90	90	90	90	90	90
Heavy Vehicles, %	2	5	2	2	2	50	2	2	2	2	2	2
Mvmt Flow	2	22	2	4	26	2	4	10	3	7	14	3

Major/Minor	Major1	Major2	Minor1	Minor2
Conflicting Flow All	76	0	0	60
Stage 1	-	-	-	-
Stage 2	-	-	-	-
Critical Hdwy	4.12	-	-	4.12
Critical Hdwy Stg 1	-	-	-	-
Critical Hdwy Stg 2	-	-	-	-
Follow-up Hdwy	2.218	-	-	2.218
Pot Cap-1 Maneuver	1523	-	-	1544
Stage 1	-	-	-	-
Stage 2	-	-	-	-
Platoon blocked, %	-	-	-	-
Mov Cap-1 Maneuver	1466	-	-	1501
Mov Cap-2 Maneuver	-	-	-	-
Stage 1	-	-	-	-
Stage 2	-	-	-	-

Approach	EB	WB	NB	SB
HCM Control Delay, s	0.6	1	9.9	10.1
HCM LOS			A	B

Minor Lane/Major Mvmt	NBLn1	EBL	EBT	EBR	WBL	WBT	WBR	SBLn1
Capacity (veh/h)	751	1466	-	-	1501	-	-	737
HCM Lane V/C Ratio	0.024	0.002	-	-	0.003	-	-	0.033
HCM Control Delay (s)	9.9	7.5	0	-	7.4	0	-	10.1
HCM Lane LOS	A	A	A	-	A	A	-	B
HCM 95th %tile Q(veh)	0.1	0	-	-	0	-	-	0.1

# Appendix D

Collision Data

Accident Date	Accident Year	Accident Time	Location	Environment Condition	Light	Traffic Control	Traffic Control Condition	Classification Of Accident	Initial Impact Type	Road Surface Condition	# Vehicles	# Motorcycles	# Bicycles	# Pedestrians
5/2/2017	2017	7:38	GOLDBURN AVE @ LAURIER AVE (0007750)	01 - Clear	01 - Daylight	02 - Stop sign	01 - Functioning	03 - P.D. only	02 - Angle	01 - Dry	2	0	0	0
1/19/2020	2020	13:15	GOLDBURN AVE @ LAURIER AVE (0007750)	01 - Clear	01 - Daylight	02 - Stop sign	01 - Functioning	03 - P.D. only	02 - Angle	05 - Packed snow	2	0	0	0
2/14/2016	2016	8:14	BLACKBURN AVE @ LAURIER AVE (0007757)	01 - Clear	01 - Daylight	02 - Stop sign	00 - Unknown	03 - P.D. only	02 - Angle	06 - Ice	2	0	0	0
10/18/2017	2017	17:00	BLACKBURN AVE @ LAURIER AVE (0007757)	01 - Clear	01 - Daylight	02 - Stop sign	01 - Functioning	03 - P.D. only	02 - Angle	01 - Dry	2	0	0	0
7/26/2017	2017	16:59	BLACKBURN AVE @ OSSGOODE ST (0007956)	01 - Clear	01 - Daylight	02 - Stop sign	01 - Functioning	03 - P.D. only	02 - Angle	01 - Dry	2	0	0	0
12/23/2018	2018	23:00	BLACKBURN AVE btwn LAURIER AVE E & OSSGOODE ST (___3ZABK)	03 - Snow	07 - Dark	10 - No control	0	03 - P.D. only	07 - SMV other	03 - Loose snow	1	0	0	0
9/20/2018	2018	8:21	BLACKBURN AVE @ LAURIER AVE (0007757)	02 - Rain	01 - Daylight	02 - Stop sign	01 - Functioning	02 - Non-fatal injury	02 - Angle	02 - Wet	2	0	0	0
11/28/2019	2019	23:58	BLACKBURN AVE @ OSSGOODE ST (0007956)	01 - Clear	07 - Dark	02 - Stop sign	00 - Unknown	03 - P.D. only	03 - Rear end	01 - Dry	2	0	0	0
11/24/2020	2020	9:30	BLACKBURN AVE @ OSSGOODE ST (0007956)	01 - Clear	01 - Daylight	02 - Stop sign	01 - Functioning	03 - P.D. only	03 - Rear end	01 - Dry	2	0	0	0
2/16/2016	2016	8:30	LAURIER AVE E btwn RUSSELL AVE & CHAPEL ST (___3ZA3V3)	03 - Snow	01 - Daylight	10 - No control	0	03 - P.D. only	06 - SMV unattended vehicle	05 - Packed snow	1	0	0	0
4/8/2016	2016	9:01	CHAPEL ST @ LAURIER AVE (0007756)	01 - Clear	01 - Daylight	01 - Traffic signal	01 - Functioning	03 - P.D. only	03 - Rear end	01 - Dry	2	0	0	0
4/9/2016	2016	23:09	LAURIER AVE E btwn RUSSELL AVE & CHAPEL ST (___3ZA3V3)	01 - Clear	07 - Dark	10 - No control	0	03 - P.D. only	07 - SMV other	01 - Dry	1	0	0	0
5/18/2016	2016	19:59	LAURIER AVE E btwn RUSSELL AVE & CHAPEL ST (___3ZA3V3)	01 - Clear	01 - Daylight	10 - No control	0	03 - P.D. only	04 - Sideswipe	01 - Dry	2	0	0	0
7/23/2016	2016	0:18	CHAPEL ST @ LAURIER AVE (0007756)	01 - Clear	07 - Dark	01 - Traffic signal	01 - Functioning	03 - P.D. only	02 - Angle	01 - Dry	2	0	0	0
9/22/2016	2016	17:37	CHAPEL ST @ LAURIER AVE (0007756)	01 - Clear	01 - Daylight	01 - Traffic signal	01 - Functioning	03 - P.D. only	05 - Turning movement	02 - Wet	2	0	0	0
9/17/2016	2016	18:00	CHAPEL ST @ LAURIER AVE (0007756)	02 - Rain	01 - Daylight	01 - Traffic signal	01 - Functioning	03 - P.D. only	02 - Angle	02 - Wet	2	0	0	0
3/16/2017	2017	7:50	LAURIER AVE E btwn RUSSELL AVE & CHAPEL ST (___3ZA3V3)	01 - Clear	01 - Daylight	10 - No control	0	03 - P.D. only	06 - SMV unattended vehicle	05 - Packed snow	1	0	0	0
3/14/2018	2018	15:01	LAURIER AVE E btwn CHAPEL ST & BLACKBURN AVE (___3ZA3V5)	03 - Snow	01 - Daylight	10 - No control	0	03 - P.D. only	03 - Rear end	02 - Wet	2	0	0	0
8/30/2018	2018	16:20	CHAPEL ST @ LAURIER AVE (0007756)	01 - Clear	01 - Daylight	01 - Traffic signal	01 - Functioning	03 - P.D. only	05 - Turning movement	01 - Dry	2	0	0	0
9/16/2018	2018	1:41	LAURIER AVE E btwn RUSSELL AVE & CHAPEL ST (___3ZA3V3)	01 - Clear	07 - Dark	10 - No control	0	03 - P.D. only	07 - SMV other	01 - Dry	1	0	0	0
2/7/2020	2020	0:02	CHAPEL ST @ LAURIER AVE (0007756)	03 - Snow	07 - Dark	01 - Traffic signal	01 - Functioning	02 - Non-fatal injury	02 - Angle	03 - Loose snow	2	0	0	0
12/13/2016	2016	9:21	RUSSELL AVE @ LAURIER AVE (0007752)	01 - Clear	01 - Daylight	02 - Stop sign	01 - Functioning	03 - P.D. only	02 - Angle	03 - Loose snow	2	0	0	0
12/10/2016	2016	14:00	RUSSELL AVE @ LAURIER AVE (0007752)	01 - Clear	01 - Daylight	02 - Stop sign	01 - Functioning	03 - P.D. only	02 - Angle	04 - Slush	2	0	0	0
1/12/2016	2016	17:47	RUSSELL AVE @ LAURIER AVE (0007752)	03 - Snow	07 - Dark	02 - Stop sign	01 - Functioning	03 - P.D. only	01 - Approaching	03 - Loose snow	2	0	0	0
6/10/2016	2016	16:50	RUSSELL AVE @ LAURIER AVE (0007752)	01 - Clear	01 - Daylight	02 - Stop sign	01 - Functioning	03 - P.D. only	02 - Angle	01 - Dry	2	0	0	0
12/22/2017	2017	15:00	RUSSELL AVE @ LAURIER AVE (0007752)	01 - Clear	01 - Daylight	02 - Stop sign	01 - Functioning	03 - P.D. only	02 - Angle	04 - Slush	2	0	0	0
7/6/2018	2018	15:44	RUSSELL AVE @ LAURIER AVE (0007752)	01 - Clear	01 - Daylight	02 - Stop sign	01 - Functioning	03 - P.D. only	02 - Angle	01 - Dry	2	0	0	0
7/14/2018	2018	21:38	RUSSELL AVE @ LAURIER AVE (0007752)	01 - Clear	07 - Dark	02 - Stop sign	01 - Functioning	03 - P.D. only	02 - Angle	01 - Dry	2	0	0	0
2/20/2019	2019	16:50	RUSSELL AVE @ LAURIER AVE (0007752)	01 - Clear	01 - Daylight	02 - Stop sign	01 - Functioning	03 - P.D. only	02 - Angle	01 - Dry	2	0	0	0

# Appendix E

TDM Checklist

**TDM Measures Checklist:**  
*Residential Developments (multi-family, condominium or subdivision)*

Legend	
<b>BASIC</b>	The measure is generally feasible and effective, and in most cases would benefit the development and its users
<b>BETTER</b>	The measure could maximize support for users of sustainable modes, and optimize development performance
<b>★</b>	The measure is one of the most dependably effective tools to encourage the use of sustainable modes

TDM measures: Residential developments		Check if proposed & add descriptions
<b>1. TDM PROGRAM MANAGEMENT</b>		
<b>1.1 Program coordinator</b>		
<b>BASIC</b> ★	1.1.1 Designate an internal coordinator, or contract with an external coordinator	<input type="checkbox"/>
<b>1.2 Travel surveys</b>		
<b>BETTER</b>	1.2.1 Conduct periodic surveys to identify travel-related behaviours, attitudes, challenges and solutions, and to track progress	<input type="checkbox"/>
<b>2. WALKING AND CYCLING</b>		
<b>2.1 Information on walking/cycling routes &amp; destinations</b>		
<b>BASIC</b>	2.1.1 Display local area maps with walking/cycling access routes and key destinations at major entrances ( <i>multi-family, condominium</i> )	<input checked="" type="checkbox"/>
<b>2.2 Bicycle skills training</b>		
<b>BETTER</b>	2.2.1 Offer on-site cycling courses for residents, or subsidize off-site courses	<input type="checkbox"/>

TDM measures: Residential developments		Check if proposed & add descriptions
<b>3. TRANSIT</b>		
<b>3.1 Transit information</b>		
<b>BASIC</b>	3.1.1 Display relevant transit schedules and route maps at entrances ( <i>multi-family, condominium</i> )	<input type="checkbox"/>
<b>BETTER</b>	3.1.2 Provide real-time arrival information display at entrances ( <i>multi-family, condominium</i> )	<input type="checkbox"/>
<b>3.2 Transit fare incentives</b>		
<b>BASIC</b> ★	3.2.1 Offer PRESTO cards preloaded with one monthly transit pass on residence purchase/move-in, to encourage residents to use transit	<input type="checkbox"/>
<b>BETTER</b>	3.2.2 Offer at least one year of free monthly transit passes on residence purchase/move-in	<input checked="" type="checkbox"/>
<b>3.3 Enhanced public transit service</b>		
<b>BETTER</b> ★	3.3.1 Contract with OC Transpo to provide early transit services until regular services are warranted by occupancy levels ( <i>subdivision</i> )	<input type="checkbox"/>
<b>3.4 Private transit service</b>		
<b>BETTER</b>	3.4.1 Provide shuttle service for seniors homes or lifestyle communities (e.g. scheduled mall or supermarket runs)	<input type="checkbox"/>
<b>4. CARSHARING &amp; BIKESHARING</b>		
<b>4.1 Bikeshare stations &amp; memberships</b>		
<b>BETTER</b>	4.1.1 Contract with provider to install on-site bikeshare station ( <i>multi-family</i> )	<input checked="" type="checkbox"/>
<b>BETTER</b>	4.1.2 Provide residents with bikeshare memberships, either free or subsidized ( <i>multi-family</i> )	<input type="checkbox"/>
<b>4.2 Carshare vehicles &amp; memberships</b>		
<b>BETTER</b>	4.2.1 Contract with provider to install on-site carshare vehicles and promote their use by residents	<input checked="" type="checkbox"/>
<b>BETTER</b>	4.2.2 Provide residents with carshare memberships, either free or subsidized	<input type="checkbox"/>
<b>5. PARKING</b>		
<b>5.1 Priced parking</b>		
<b>BASIC</b> ★	5.1.1 Unbundle parking cost from purchase price ( <i>condominium</i> )	<input checked="" type="checkbox"/>
<b>BASIC</b> ★	5.1.2 Unbundle parking cost from monthly rent ( <i>multi-family</i> )	<input type="checkbox"/>

TDM measures: Residential developments		Check if proposed & add descriptions
<b>6. TDM MARKETING &amp; COMMUNICATIONS</b>		
<b>6.1 Multimodal travel information</b>		
BASIC ★	6.1.1 Provide a multimodal travel option information package to new residents	<input checked="" type="checkbox"/>
<b>6.2 Personalized trip planning</b>		
BETTER ★	6.2.1 Offer personalized trip planning to new residents	<input type="checkbox"/>

**TDM-Supportive Development Design and Infrastructure Checklist:**  
*Residential Developments (multi-family or condominium)*

Legend	
REQUIRED	The Official Plan or Zoning By-law provides related guidance that must be followed
BASIC	The measure is generally feasible and effective, and in most cases would benefit the development and its users
BETTER	The measure could maximize support for users of sustainable modes, and optimize development performance

TDM-supportive design & infrastructure measures: Residential developments		Check if completed & add descriptions, explanations or plan/drawing references
<b>1. WALKING &amp; CYCLING: ROUTES</b>		
<b>1.1 Building location &amp; access points</b>		
BASIC	1.1.1 Locate building close to the street, and do not locate parking areas between the street and building entrances	<input checked="" type="checkbox"/>
BASIC	1.1.2 Locate building entrances in order to minimize walking distances to sidewalks and transit stops/stations	<input checked="" type="checkbox"/>
BASIC	1.1.3 Locate building doors and windows to ensure visibility of pedestrians from the building, for their security and comfort	<input checked="" type="checkbox"/>
<b>1.2 Facilities for walking &amp; cycling</b>		
REQUIRED	1.2.1 Provide convenient, direct access to stations or major stops along rapid transit routes within 600 metres; minimize walking distances from buildings to rapid transit; provide pedestrian-friendly, weather-protected (where possible) environment between rapid transit accesses and building entrances; ensure quality linkages from sidewalks through building entrances to integrated stops/stations (see Official Plan policy 4.3.3)	<input type="checkbox"/>
REQUIRED	1.2.2 Provide safe, direct and attractive pedestrian access from public sidewalks to building entrances through such measures as: reducing distances between public sidewalks and major building entrances; providing walkways from public streets to major building entrances; within a site, providing walkways along the front of adjoining buildings, between adjacent buildings, and connecting areas where people may congregate, such as courtyards and transit stops; and providing weather protection through canopies, colonnades, and other design elements wherever possible (see Official Plan policy 4.3.12)	<input checked="" type="checkbox"/>

TDM-supportive design & infrastructure measures: <i>Residential developments</i>		Check if completed & add descriptions, explanations or plan/drawing references
REQUIRED	1.2.3 Provide sidewalks of smooth, well-drained walking surfaces of contrasting materials or treatments to differentiate pedestrian areas from vehicle areas, and provide marked pedestrian crosswalks at intersection sidewalks (see <i>Official Plan policy 4.3.10</i> )	<input checked="" type="checkbox"/>
REQUIRED	1.2.4 Make sidewalks and open space areas easily accessible through features such as gradual grade transition, depressed curbs at street corners and convenient access to extra-wide parking spaces and ramps (see <i>Official Plan policy 4.3.10</i> )	<input checked="" type="checkbox"/>
REQUIRED	1.2.5 Include adequately spaced inter-block/street cycling and pedestrian connections to facilitate travel by active transportation. Provide links to the existing or planned network of public sidewalks, multi-use pathways and on-road cycle routes. Where public sidewalks and multi-use pathways intersect with roads, consider providing traffic control devices to give priority to cyclists and pedestrians (see <i>Official Plan policy 4.3.11</i> )	<input checked="" type="checkbox"/>
BASIC	1.2.6 Provide safe, direct and attractive walking routes from building entrances to nearby transit stops	<input checked="" type="checkbox"/>
BASIC	1.2.7 Ensure that walking routes to transit stops are secure, visible, lighted, shaded and wind-protected wherever possible	<input type="checkbox"/>
BASIC	1.2.8 Design roads used for access or circulation by cyclists using a target operating speed of no more than 30 km/h, or provide a separated cycling facility	<input type="checkbox"/>
<b>1.3 Amenities for walking &amp; cycling</b>		
BASIC	1.3.1 Provide lighting, landscaping and benches along walking and cycling routes between building entrances and streets, sidewalks and trails	<input type="checkbox"/>
BASIC	1.3.2 Provide wayfinding signage for site access (where required, e.g. when multiple buildings or entrances exist) and egress (where warranted, such as when directions to reach transit stops/stations, trails or other common destinations are not obvious)	<input type="checkbox"/>

TDM-supportive design & infrastructure measures: <i>Residential developments</i>		Check if completed & add descriptions, explanations or plan/drawing references
<b>2. WALKING &amp; CYCLING: END-OF-TRIP FACILITIES</b>		
<b>2.1 Bicycle parking</b>		
REQUIRED	2.1.1 Provide bicycle parking in highly visible and lighted areas, sheltered from the weather wherever possible (see <i>Official Plan policy 4.3.6</i> )	<input checked="" type="checkbox"/>
REQUIRED	2.1.2 Provide the number of bicycle parking spaces specified for various land uses in different parts of Ottawa; provide convenient access to main entrances or well-used areas (see <i>Zoning By-law Section 111</i> )	<input checked="" type="checkbox"/>
REQUIRED	2.1.3 Ensure that bicycle parking spaces and access aisles meet minimum dimensions; that no more than 50% of spaces are vertical spaces; and that parking racks are securely anchored (see <i>Zoning By-law Section 111</i> )	<input checked="" type="checkbox"/>
BASIC	2.1.4 Provide bicycle parking spaces equivalent to the expected number of resident-owned bicycles, plus the expected peak number of visitor cyclists	<input type="checkbox"/>
<b>2.2 Secure bicycle parking</b>		
REQUIRED	2.2.1 Where more than 50 bicycle parking spaces are provided for a single residential building, locate at least 25% of spaces within a building/structure, a secure area (e.g. supervised parking lot or enclosure) or bicycle lockers (see <i>Zoning By-law Section 111</i> )	<input checked="" type="checkbox"/>
BETTER	2.2.2 Provide secure bicycle parking spaces equivalent to at least the number of units at condominiums or multi-family residential developments	<input type="checkbox"/>
<b>2.3 Bicycle repair station</b>		
BETTER	2.3.1 Provide a permanent bike repair station, with commonly used tools and an air pump, adjacent to the main bicycle parking area (or secure bicycle parking area, if provided)	<input type="checkbox"/>
<b>3. TRANSIT</b>		
<b>3.1 Customer amenities</b>		
BASIC	3.1.1 Provide shelters, lighting and benches at any on-site transit stops	<input type="checkbox"/>
BASIC	3.1.2 Where the site abuts an off-site transit stop and insufficient space exists for a transit shelter in the public right-of-way, protect land for a shelter and/or install a shelter	<input type="checkbox"/>
BETTER	3.1.3 Provide a secure and comfortable interior waiting area by integrating any on-site transit stops into the building	<input type="checkbox"/>

TDM-supportive design & infrastructure measures: <i>Residential developments</i>		Check if completed & add descriptions, explanations or plan/drawing references
<b>4. RIDESHARING</b>		
<b>4.1 Pick-up &amp; drop-off facilities</b>		
BASIC	4.1.1 Provide a designated area for carpool drivers (plus taxis and ride-hailing services) to drop off or pick up passengers without using fire lanes or other no-stopping zones	<input type="checkbox"/>
<b>5. CARSHARING &amp; BIKESHARING</b>		
<b>5.1 Carshare parking spaces</b>		
BETTER	5.1.1 Provide up to three carshare parking spaces in an R3, R4 or R5 Zone for specified residential uses (see <i>Zoning By-law Section 94</i> )	<input type="checkbox"/>
<b>5.2 Bikeshare station location</b>		
BETTER	5.2.1 Provide a designated bikeshare station area near a major building entrance, preferably lighted and sheltered with a direct walkway connection	<input type="checkbox"/>
<b>6. PARKING</b>		
<b>6.1 Number of parking spaces</b>		
REQUIRED	6.1.1 Do not provide more parking than permitted by zoning, nor less than required by zoning, unless a variance is being applied for	<input checked="" type="checkbox"/>
BASIC	6.1.2 Provide parking for long-term and short-term users that is consistent with mode share targets, considering the potential for visitors to use off-site public parking	<input type="checkbox"/>
BASIC	6.1.3 Where a site features more than one use, provide shared parking and reduce the cumulative number of parking spaces accordingly (see <i>Zoning By-law Section 104</i> )	<input type="checkbox"/>
BETTER	6.1.4 Reduce the minimum number of parking spaces required by zoning by one space for each 13 square metres of gross floor area provided as shower rooms, change rooms, locker rooms and other facilities for cyclists in conjunction with bicycle parking (see <i>Zoning By-law Section 111</i> )	<input type="checkbox"/>
<b>6.2 Separate long-term &amp; short-term parking areas</b>		
BETTER	6.2.1 Provide separate areas for short-term and long-term parking (using signage or physical barriers) to permit access controls and simplify enforcement (i.e. to discourage residents from parking in visitor spaces, and vice versa)	<input type="checkbox"/>



# Appendix F

Blackburn Avenue Signage Plan

Notes:

01	Issued for Review	MS	2023-11-14
REV.	DESCRIPTION	BY	DATE
STATUS:			

CGH Transportation  
 6 Plaza Court  
 Oshawa, ON  
 L2H 7Y6  
 (416) 999-9117



CLIENT: Windmill  
 ARCHITECT:

SITE: 315 Chapel		TITLE: Signage Plan	
SCALE AT AS:	DATE:	DRAWN:	CHECKED:
NTS	2023-11-14	MS	JK
PROJECT NO:	DRAWING NO:	REVISION:	
2023-022	001	01	

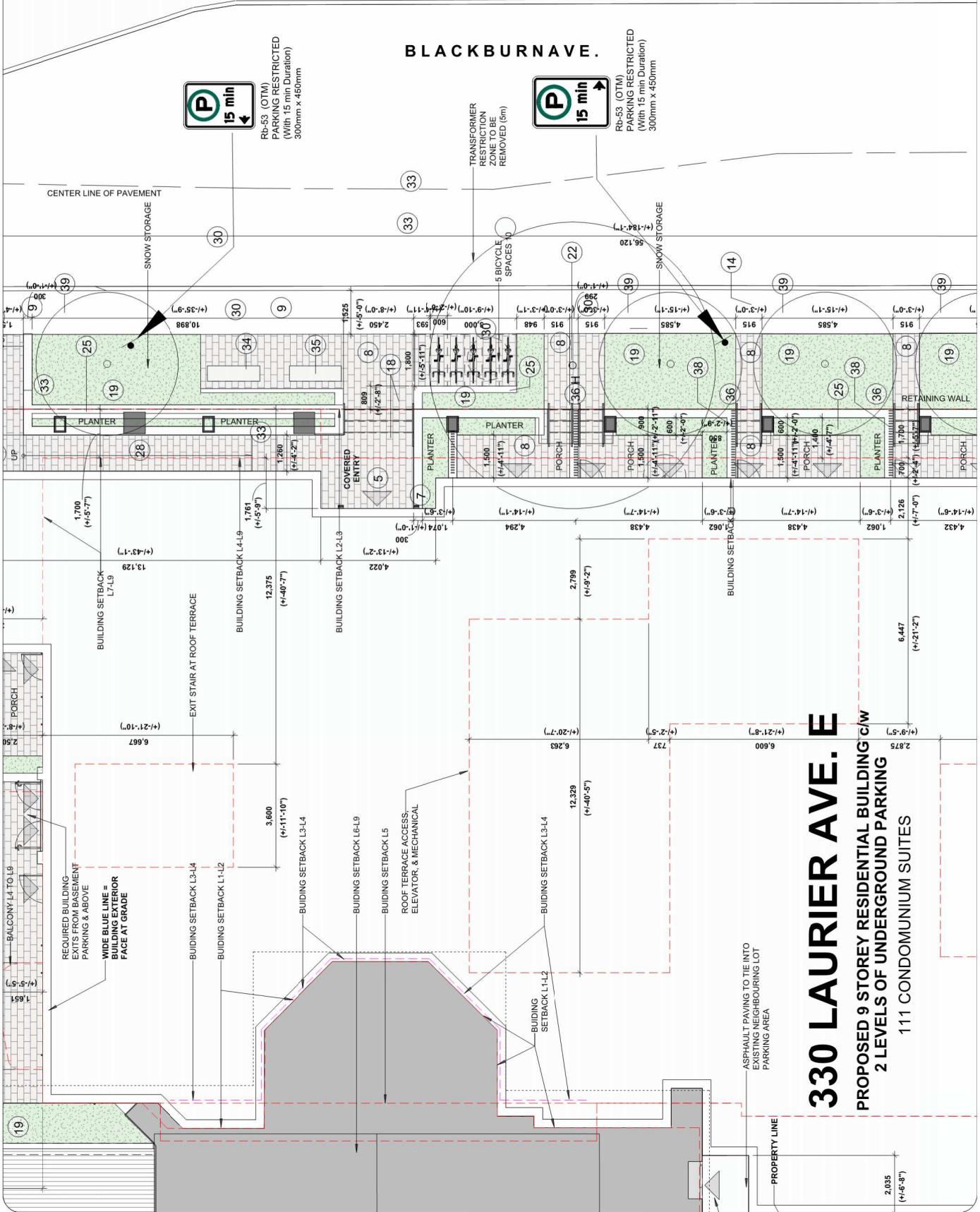

# Appendix G

MMLOS Analysis

# Multi-Modal Level of Service - Segments Form

Consultant Scenario Comments	CGH Transportation Inc	Project Date	2023-022
	Existing/Future		2023-07-19

SEGMENTS			Laurier Ave	Blackburn Ave	Blackburn Ave
			Ex./Fut.	Ex.	Fut.
Pedestrian	Sidewalk Width	-	1.5 m	< 1.5 m	1.5 m
	Boulevard Width		0.5 - 2 m	n/a	< 0.5 m
	Avg Daily Curb Lane Traffic Volume		≤ 3000	≤ 3000	≤ 3000
	Operating Speed		> 50 to 60 km/h	> 30 to 50 km/h	> 30 to 50 km/h
	On-Street Parking		yes	yes	yes
	<b>Exposure to Traffic PLoS</b>		<b>C</b>	<b>F</b>	<b>E</b>
	Effective Sidewalk Width				
Pedestrian Volume					
<b>Crowding PLoS</b>	-	-	-		
<b>Level of Service</b>	-	-	-		
Bicycle	Type of Cycling Facility	F	Mixed Traffic	Mixed Traffic	Mixed Traffic
	Number of Travel Lanes		2-3 lanes total	≤ 2 (no centreline)	≤ 2 (no centreline)
	Operating Speed		≥ 60 km/h	>40 to <50 km/h	>40 to <50 km/h
	<b># of Lanes &amp; Operating Speed LoS</b>		<b>F</b>	<b>B</b>	<b>B</b>
	Bike Lane (+ Parking Lane) Width				
	<b>Bike Lane Width LoS</b>		-	-	-
	Bike Lane Blockages				
	<b>Blockage LoS</b>		-	-	-
	Median Refuge Width (no median = < 1.8 m)		< 1.8 m refuge	< 1.8 m refuge	< 1.8 m refuge
	No. of Lanes at Unsignalized Crossing		≤ 3 lanes	≤ 3 lanes	≤ 3 lanes
Sidestreet Operating Speed	≤ 40 km/h	≤ 40 km/h	≤ 40 km/h		
<b>Unsignalized Crossing - Lowest LoS</b>	<b>A</b>	<b>A</b>	<b>A</b>		
<b>Level of Service</b>	<b>F</b>	<b>B</b>	<b>B</b>		
Transit	Facility Type	D	Mixed Traffic		
	Friction or Ratio Transit:Posted Speed		Vt/Vp ≥ 0.8		
<b>Level of Service</b>	<b>D</b>	-	-		
Truck	Truck Lane Width	-			
	Travel Lanes per Direction				
<b>Level of Service</b>	-	-	-		
Auto	<b>Level of Service</b>	<b>Not Applicable</b>			