



**2948 BASELINE ROAD SERVICING AND  
STORMWATER MANAGEMENT REPORT**

May 25, 2023

Prepared for:  
11034936 Canada Inc.

Prepared by:  
Stantec Consulting Ltd.

Project Number:  
160401676

## 2948 Baseline Road Servicing and Stormwater Management Report

<b>Revision</b>	<b>Description</b>	<b>Author</b>	<b>Date</b>	<b>Quality Check</b>	<b>Date</b>	<b>Independent Review</b>	<b>Date</b>
0	SPA 1 <sup>st</sup> Submission	P.Mott	5/25/2023	R.Brandrick	5/25/2023	K.Kilborn	5/25/2023



## 2948 Baseline Road Servicing and Stormwater Management Report

The conclusions in the Report titled 2948 Baseline Road Servicing and Stormwater Management Report are Stantec's professional opinion, as of the time of the Report, and concerning the scope described in the Report. The opinions in the document are based on conditions and information existing at the time the scope of work was conducted and do not take into account any subsequent changes. The Report relates solely to the specific project for which Stantec was retained and the stated purpose for which the Report was prepared. The Report is not to be used or relied on for any variation or extension of the project, or for any other project or purpose, and any unauthorized use or reliance is at the recipient's own risk.

Stantec has assumed all information received from 11034936 Canada Inc. (the "Client") and third parties in the preparation of the Report to be correct. While Stantec has exercised a customary level of judgment or due diligence in the use of such information, Stantec assumes no responsibility for the consequences of any error or omission contained therein.

This Report is intended solely for use by the Client in accordance with Stantec's contract with the Client. While the Report may be provided by the Client to applicable authorities having jurisdiction and to other third parties in connection with the project, Stantec disclaims any legal duty based upon warranty, reliance or any other theory to any third party, and will not be liable to such third party for any damages or losses of any kind that may result.

Prepared By: \_\_\_\_\_



**Peter Mott, EIT**

Reviewed By: \_\_\_\_\_



**Rob Brandrick, P.Eng.**



Approved By: \_\_\_\_\_

**Kris Kilborn**



## Table of Contents

<b>1.0</b>	<b>INTRODUCTION.....</b>	<b>1.1</b>
1.1	Objective.....	1.2
<b>2.0</b>	<b>BACKGROUND.....</b>	<b>2.1</b>
<b>3.0</b>	<b>WATER SERVICING .....</b>	<b>3.1</b>
3.1	Background .....	3.1
3.2	Water Demand .....	3.1
3.2.1	Water Demand .....	3.1
3.2.2	Fire Flow Demand .....	3.2
3.3	Level of Service .....	3.2
3.3.1	Boundary Conditions .....	3.2
3.3.2	Allowable Domestic Pressures .....	3.3
3.3.3	Fire Flow .....	3.3
3.3.4	Fire Hydrant Coverage .....	3.3
3.4	Proposed Water Servicing.....	3.5
<b>4.0</b>	<b>WASTEWATER SERVICING.....</b>	<b>4.1</b>
4.1	Design Criteria .....	4.1
4.2	Wastewater Generation and Servicing Design .....	4.1
4.3	Proposed Sanitary Servicing .....	4.2
<b>5.0</b>	<b>STORMWATER MANAGEMENT AND SERVICING .....</b>	<b>5.1</b>
5.1	Objectives .....	5.1
5.2	Stormwater Management (SWM) Criteria .....	5.1
5.3	Existing Conditions .....	5.2
5.4	Stormwater Management Design .....	5.2
5.4.1	Allowable Release Rate .....	5.3
5.4.2	Quantity Control: Storage Requirements .....	5.3
5.5	Proposed Stormwater Servicing.....	5.5
<b>6.0</b>	<b>SITE GRADING .....</b>	<b>6.1</b>
<b>7.0</b>	<b>UTILITIES.....</b>	<b>7.1</b>
<b>8.0</b>	<b>APPROVALS.....</b>	<b>8.1</b>
<b>9.0</b>	<b>EROSION AND SEDIMENT CONTROL DURING CONSTRUCTION.....</b>	<b>9.1</b>
<b>10.0</b>	<b>GEOTECHNICAL INVESTIGATION .....</b>	<b>10.1</b>
<b>11.0</b>	<b>CONCLUSIONS.....</b>	<b>11.1</b>
11.1	Water Servicing .....	11.1
11.2	Sanitary Servicing.....	11.1
11.3	Stormwater Servicing and Management .....	11.1
11.4	Grading .....	11.2
11.5	Erosion and Sediment Control During Construction .....	11.2
11.6	Geotechnical Investigation .....	11.2
11.7	Utilities .....	11.2
11.8	Approvals.....	11.2



**LIST OF TABLES**

Table 3-1: Estimated Water Demands ..... 3.2  
Table 3-2: Boundary Conditions ..... 3.2  
Table 3-3: Tower 5 - Fire Hydrant Coverage ..... 3.5  
Table 4-1 - Estimated Total Wastewater Peak Flow ..... 4.2  
Table 5-1: Peak Pre-Development Flow Rates ..... 5.2  
Table 5-2: Target Release Rate ..... 5.3  
Table 5-3: Peak Uncontrolled 5-Year and 100-Year Run-Off ..... 5.4  
Table 5-4: Proposed Cistern Sizing for 5-Year and 100-Year Storage Requirement ..... 5.4  
Table 5-5: Estimated Post-Development Discharge ..... 5.5  
Table 10-1: Recommended Pavement Structure ..... 10.1

**LIST OF FIGURES**

Figure 1-1: Key Plan of Site ..... 1.1  
Figure 3-1: Fire Hydrant Coverage Sketch ..... 3.4

**LIST OF APPENDICES**

**APPENDIX A SITE PLAN ..... A.1**  
**APPENDIX B WATER DEMAND ..... B.1**  
B.1 Domestic Water Demand ..... B.1  
B.2 Fire Flow Demands (FUS 2020) ..... B.2  
B.3 Boundary Conditions ..... B.3  
B.4 Fire Hydrant Coverage Calculations ..... B.4  
**APPENDIX C SANITARY ..... C.1**  
C.1 Sanitary Sewer Design Sheet ..... C.1  
**APPENDIX D STORMWATER SERVICING ..... D.1**  
D.1 Pre-consultation Information ..... D.1  
D.2 Modified Rational Method Sheet ..... D.2  
D.3 Storm Sewer Design Sheet ..... D.3  
**APPENDIX E GEOTECHNICAL INVESTIGATION (PATERSON GROUP) ..... E.1**  
**APPENDIX F PRE-CONSULTATION NOTES ..... F.1**  
**APPENDIX G DRAWINGS ..... G.1**



## 1.0 Introduction

Stantec Consulting Ltd. is commissioned by 11034936 Canada Inc. to prepare the following Servicing and Stormwater Management Report in support of a Rezoning and Complex Site Plan application for the proposed development located at 2948 Baseline Road in the City of Ottawa.

The site is 1.19 ha in area and is situated along the south side of Baseline Road, the east side of Sandcastle Drive, the west side of an existing and future mixed-use development site, and the north side of an existing residential site. The site is currently zoned GM [2138] S325-h and consists of an existing commercial mall with surface parking lots. The site is bounded by Baseline Road to the north, Sandcastle Drive to the west, existing and future mixed-use development to the east, and existing residential development to the south, as shown in **Figure 1-1** below.



**Figure 1-1: Key Plan of Site**

The 1.19 ha site is to be developed in three phases and comprises of three residential high-rises with 700 residential units, a six-storey podium, and 1515.0 m<sup>2</sup> of commercial spaces, three townhouses, and a



0.118 ha park between Towers 4 and 5. The proposed buildings will include 124 studio units, 294 one-bedroom units, 239 two-bedroom units, and 40 three-bedroom units. The site plan prepared by Neuf Architect(e)s, dated April 11, 2023, defines the proposed development (see **Appendix A**).

### 1.1 Objective

This site servicing and stormwater management (SWM) report presents a servicing scheme that is free of conflicts, provides on-site servicing in accordance with City of Ottawa Design Guidelines, and uses the existing municipal infrastructure in accordance with any limitations communicated during consultation with the City of Ottawa staff. Details of the existing infrastructure located within the Baseline Road and Sandcastle Drive right of ways (ROW) are obtained from available as-built drawings and site topographic survey.

Criteria and constraints provided by the City of Ottawa are used as a basis for the detailed servicing design of the proposed development. Specific and potential development constraints to be addressed are as follows:

- Potable Water Servicing
  - Estimated water demands to characterize the proposed feed(s) for the proposed development to be serviced from the existing 200 mm diameter watermain within the private driveway separating the existing mixed-use development along the east boundary of the site.
  - Watermain servicing for the development is to be able to provide average day and maximum day (including peak hour) demands (i.e., non-emergency conditions) at pressures within the acceptable range of 345 to 552 kPa (50 to 80 psi)
  - Under fire flow (emergency) conditions, the water distribution system is to maintain a minimum pressure greater than 140 kPa (20 psi)
- Wastewater (Sanitary) Servicing
  - Define and size the sanitary service laterals which will be connected to the existing 250 mm diameter sanitary sewer within the Sandcastle Drive ROW.
- Storm Sewer Servicing
  - Define major and minor conveyance systems in conjunction with the proposed grading plan.
  - Determine the stormwater management storage requirements to meet the allowable release rate for the site.
  - Define and size the proposed storm service laterals to be connected to the existing 375 mm and 450 mm diameter municipal storm sewers within the Sandcastle Drive ROW.
- Prepare a grading plan in accordance with the proposed site plan and existing grades.

The accompanying drawings included in **Appendix G** illustrate the proposed internal servicing scheme for the site.



### 2.0 Background

Documents referenced in preparing of this stormwater and servicing report for the 2948 Baseline Road development include:

- *City of Ottawa Sewer Design Guidelines (SDG)*, City of Ottawa, October 2012, including all subsequent technical bulletins
- *City of Ottawa Design Guidelines – Water Distribution*, City of Ottawa, July 2010, including all subsequent technical bulletins
- *Design Guidelines for Drinking Water Systems*, Ministry of the Environment, Conservation, and Parks (MECP), 2008
- *Fire Protection Water Supply Guideline for Part 3 in the Ontario Building Code*, Office of the Fire Marshal (OFM), October 2020
- *Water Supply for Public Fire Protection*, Fire Underwriters Survey (FUS), 2020
- *2940/2946/2948 Baseline Road Development Servicing and Stormwater Management Report*, Novatech, Revision 4, December 18, 2015
- *Geotechnical Investigation – Proposed Multi-Storey Building – Tower 4 to 6, 2946 Baseline Road, Ottawa, Ontario*, Paterson Group Inc., March 24, 2022





## 3.0 Water Servicing

### 3.1 Background

The proposed building is in Pressure Zone 2W2C of the City of Ottawa's Water Distribution System. The existing watermain along the boundaries of the site consists of a 200 mm diameter duct iron watermain in Sandcastle Drive, a 1200 mm diameter C01 watermain in Baseline Road, and the private 200 mm diameter PVC watermain in the private driveway separating the site from the existing mixed-use development at the east and going through the site along the north side of the existing commercial building.

There is an existing fire hydrant in the site, which will be relocated during construction. The existing commercial building on site is serviced by a 200mm service connected to the private watermain within the site. The Existing Conditions and Removals Plan (see **Drawing EX-1** in **Appendix G**) illustrates the existing watermain.

### 3.2 Water Demand

#### 3.2.1 WATER DEMAND

For each phase of development, water demands are estimated based on the unit mix of the site plan provided by Neuf Architect(e)s (see **Appendix A**). Tower 4 is a 9-storey mixed-use building with 52 studio units, 23 one-bedroom units, 20 two-bedroom units, 9 three-bedroom units, and 426 m<sup>2</sup> of commercial space. Tower 5 is a 28-storey mixed-use high-rise building with a six-storey podium with 20 studio units, 147 one-bedroom units, 96 two-bedroom units, 15 three-bedroom units, 3 townhouses, and 118 m<sup>2</sup> of commercial space. Tower 6 is a 32-storey mixed-use high-rise building sharing the six-storey podium with Tower 5 and consists of 52 studio units, 124 one-bedroom units, 123 two-bedroom units, 16 three-bedroom units, and 971 m<sup>2</sup> of commercial space.

The City of Ottawa Water Distribution Guidelines (July 2010) and ISTB 2021-03 Technical Bulletin are used to determine water demands based on projected population densities for residential areas and peaking factors. The population is estimated using an occupancy of 1.4 persons per unit for studio and one-bedroom apartments, 2.1 persons per unit for two-bedroom apartments, 3.1 persons per unit for three-bedroom apartments, and 2.7 persons per unit for townhouses.

A daily rate of 280 L/cap/day is used to estimate average daily (AVDY) potable water demand for the residential units, and 28,000 L/gross ha/day for the commercial spaces. Maximum day (MXDY) demands are determined by multiplying the AVDY demands by a factor of 2.5 for residential areas and 1.5 for commercial areas. Peak hourly (PKHR) demands are determined by multiplying the MXDY by a factor of 2.2 for residential areas and 1.8 for commercial areas. The estimated demands for each commercial and residential plot are summarized in **Table 3-1** below.



**Table 3-1: Estimated Water Demands**

Tower	Comm. Area (m <sup>2</sup> )	Total Apartment Units	Total Townhome Units	Population	AVDY (L/s)	MXDY (L/s)	PKHR (L/s)
4	426	104	0	175	0.70	1.62	3.49
5	118	278	3	490	1.63	4.03	8.84
6	971	315	0	554	2.11	4.96	10.73
<b>Total</b>	<b>1515</b>	<b>697</b>	<b>3</b>	<b>1219</b>	<b>4.44</b>	<b>10.61</b>	<b>23.06</b>

The supporting water demand calculations are included in **Appendix B.1**.

### 3.2.2 FIRE FLOW DEMAND

Based on the site plan, the fire flow requirement is calculated in accordance with Fire Underwriters Survey (FUS) methodology. Through correspondence with the architect, all three towers are to be sprinklered with floor assemblies/load bearing walls as 1-hour rated assemblies as per Section 3.2.2.53 of the Ontario Building Code with non-combustible construction.

As such, fire flows are estimated based on a building of non-combustible construction type with two-hour fire rated structural members, and full protections of all vertical openings (one hour fire rating), and the final sprinkler design to conform to the NFPA 13 standard. The gross floor area of the largest floor + 25 % of the gross floor area of two additional floors is used in the FUS calculation for the two high-rises, as per Page 22 of the *Fire Underwriters Survey's Water Supply for Public Fire Protection* (2020).

The worst-case scenario for the fire flow is at Tower 5, in which the required fire flow is determined to be 83.3 L/s (5,000 L/min). Detailed fire flow calculations per the FUS methodology are provided in **Appendix B.2**.

## 3.3 Level of Service

### 3.3.1 BOUNDARY CONDITIONS

The estimated domestic potable water demands, and fire flow demands, are used to define the level of servicing required for the proposed development from the municipal watermain and hydrants within the Baseline Road and Sandcastle Drive ROWs. **Table 3-2** outlines the boundary conditions provided by the City of Ottawa on May 11, 2023 (See **Appendix B.3** for correspondence).

**Table 3-2: Boundary Conditions**

Connection	Baseline Road	Sandcastle Drive 1	Sandcastle Drive 2
Min. HGL (m)	126.7		
Max. HGL (m)	133.0		
MXDY+FF (83.3 L/s) (m)	129.6	127.2	127.6



### 3.3.2 ALLOWABLE DOMESTIC PRESSURES

The desired normal operating pressure range in occupied areas as per the City of Ottawa 2010 Water Distribution Design Guidelines is 345 kPa to 552 kPa (50 psi to 80 psi) under a condition of maximum daily flow and no less than 276 kPa (40 psi) under a condition of maximum hourly demand. Furthermore, the maximum pressure at any point in the water distribution should not exceed 689 kPa (100 psi) as per the Ontario Building/Plumbing Code; pressure reducing measures are required to service areas where pressures greater than 552 kPa (80 psi) are anticipated in occupied areas.

The proposed finished floor elevations of Tower 4, Tower 5, and Tower 6 are 78.70 m, 79.60 m, and 81.0 m, respectively. These elevations serve as the ground elevation for the calculation of residual pressures at ground level. On-site (ground level) pressures are expected to range from 448 kPa to 532 kPa (65 psi to 77 psi) under normal operating conditions. These values are within the normal operating pressure range as defined by City of Ottawa design guidelines, desired 345 kPa (50 psi) to 552 kPa (80 psi) and not less than 276 kPa (40 psi).

Conditions required to maintain suitable water pressure associated with the anticipated pressure drop of 30kPa (4.3psi) per floor are to be established by the building mechanical engineering design.

### 3.3.3 FIRE FLOW

The boundary conditions provided for the proposed development under maximum day demands establish that a maximum flowrate of 83 L/s is available at the municipal watermain and that a residual pressure above the required minimum 138 kPa (20 psi) can be achieved. This indicates that sufficient fire flow is available for the proposed development.

Suitable water supply and pressure conditions for the building sprinkler system are to be established by the building mechanical engineering design.

### 3.3.4 FIRE HYDRANT COVERAGE

The buildings will be sprinklered and Siamese (fire department) connections are to be provided by the main entrances. There are four existing fire hydrants in proximity of the site, three of which are located along the west property line along Sandcastle Drive and the fourth on site and serviced by the existing private watermain, as shown in **Figure 3-1** below. All four fire hydrants are located less than 115 m from the buildings.

As part of the servicing plan, the private fire hydrant serviced by the private watermain on site is to be relocated and an additional private fire hydrant is proposed. According to the NFPA 1 Table 18.5.4.3 and as referenced in Technical Bulletin ISTB-2018-02 by the City of Ottawa, a hydrant situated less than 76 m away from a building can supply a maximum capacity of 5,678 L/min. Hence, the required fire flow demand for this site (5,000 L/min) can be achieved with each of the five fire hydrants. See **Appendix B.4** for fire hydrant coverage table calculations and NFPA Table 18.5.4.3.





**Figure 3-1: Fire Hydrant Coverage Sketch**

As per Section 3.2.5.16 of the Ontario Building Code (OBC), the distance between the fire department connection and hydrant must be unobstructed and cannot be more than 45 m. As such, the site is suitably served by the five fire hydrants, which provide the adequate fire flows from an unobstructed distance less than 45 m to the fire department connection and meet the OBC requirements.

The results of the fire hydrant coverage analysis for Tower 5, which is the worst-case exposure scenario that will yield the highest fire flow within the development, has been summarized in **Table 3-3: Tower 5 - Fire Hydrant Coverage**.



Table 3-3: Tower 5 - Fire Hydrant Coverage

Description	Hydrants				Total Available Fire Flow (L/min)	Total Required Fire Flow (L/min)
	HYD-01	HYD-02	HYD-03	HYD-04		
Distance from building (m)	105	66	52	85	-	-
Direction from building	North	South	West	West	-	-
Maximum fire flow capacity (L/min)	3,785	5,678	5,678	3,785	18,926	5,000

### 3.4 Proposed Water Servicing

The development is to be serviced by twin 200 mm building service connections to each building. Each twin 200mm service connection is connected to the private 200mm watermain along the east boundary of the site.

The existing 200mm private watermain along the east boundary is to be extended around the south boundary of the site and connected to the 200mm watermain in Sandcastle Drive.

To facilitate the building construction, the existing 200mm private watermain through the site is to be removed and then replaced with a 200mm connection passing through the building. This maintains the function of the existing watermain as a part of the water servicing system. The details of the watermain replacement through the building are to be included with the mechanical engineering design for the buildings.

The proposed servicing strategy implementing siamese water services for each proposed tower meets the City of Ottawa water supply objective that limits a single feed to 50 m<sup>3</sup>/d during basic day demands. The existing 200 mm diameter PVC watermain internal to the site and the 200 mm diameter ductile iron watermain within Sandcastle Drive can provide adequate fire and domestic flows for the subject site based on the City of Ottawa Design Guidelines and FUS (2020) calculations. A combination of any two of the fire hydrants within the vicinity, or internal of the subject site will provide sufficient fire suppression.



## 4.0 Wastewater Servicing

The existing commercial building on the site is serviced by a sanitary service lateral connected to the existing 450 mm diameter sanitary sewer in Baseline Road. The service lateral and manholes will be decommissioned, capped, and abandoned at the property line per City Standard S11.4, as shown in Existing Conditions and Removals Plan (see **Drawing EX-1** in **Appendix G**).

### 4.1 Design Criteria

As outlined in the City of Ottawa Sewer Design Guidelines and the MECP Design Guidelines for Sewage Works, the following criteria are used to calculate the estimated wastewater flow rates and to determine the size and location of the sanitary service lateral:

- Minimum velocity = 0.6 m/s (0.8 m/s for upstream sections)
- Maximum velocity = 3.0 m/s
- Manning roughness coefficient for all smooth wall pipes = 0.013
- Minimum size of sanitary sewer service = 135 mm
- Minimum grade of sanitary sewer service = 1.0 % (2.0 % preferred)
- Average wastewater generation = 280 L/person/day (per City Design Guidelines)
- Peak Factor = based on Harmon Equation; maximum of 4.0 (residential)
- Harmon correction factor = 0.8
- Infiltration allowance = 0.33 L/s/ha (per City Design Guidelines)
- Minimum cover for sewer service connections – 2.0 m
- Population density for one-bedroom apartments – 1.4 persons/apartment
- Population density for two-bedroom apartments – 2.1 persons/apartment
- Population density for three-bedroom apartments – 3.1 persons/apartment
- Population density for general townhome – 2.7 persons/unit
- Average commercial wastewater generation – 28,000 L/ha/day of building space

### 4.2 Wastewater Generation and Servicing Design

A sanitary sewer design sheet is prepared and is included in **Appendix C.1**. The estimated wastewater flows to be generated are based on the current site plan and consists of 418 one-bedroom units, 239 two-bedroom units, 40 three-bedroom units, 3 townhouses, and 0.152 ha of commercial space. The peak wastewater flows are calculated to be 15.5 L/s for the entire site, with sub-totals for each building also provided in the design sheet. The anticipated wastewater peak flow generated from the proposed development is summarized in **Table 4-1** - Estimated Total Wastewater Peak Flow below:



Table 4-1 - Estimated Total Wastewater Peak Flow

Tower	Residential Units				Commercial Areas			Infiltration Flow (L/s)	Total Peak Flow (L/s)
	Unit Count	Population	Peak Factor	Peak Flow (L/s)	Area (ha)	Peak Factor	Peak Flow (L/s)		
4	104	175	4.0	2.3	0.04	1.5	0.02	0.1	2.4
5 & 6	596	1044	3.8	12.8	0.11	1.5	0.05	0.3	13.1
<b>Total Estimated Wastewater Peak Flow (L/s):</b>									<b>15.5</b>

1. Design residential flow based on 280 L/p/day and design commercial flow based on 28,000 L/ha/day.
2. Peak factor for residential units calculated using Harmon's formula and taken as 1.50 for commercial areas.
3. Residential population estimated based on 1.4 persons/unit for one-bedroom apartments, 2.1 persons/unit for two-bedroom units, 3.1 persons/unit for three-bedroom units, and 2.7 persons/unit for townhouses.
4. Infiltration design flow equals 0.33 L/s/ha.

The anticipated peak wastewater flows for the proposed development are provided to the City of Ottawa staff to evaluate the adequacy of the receiving municipal sanitary sewer system in the vicinity of the site and downstream network.

### 4.3 Proposed Sanitary Servicing

Two 200 mm diameter sanitary building services, complete with full port backwater valve as per City standard S14.1, are proposed to service the proposed development. The sanitary laterals are to be equipped with a sanitary monitor manhole, anchored as per S.P. No. F-4070, before connecting to the sewer main with a riser pipe as per City standard S11.1. The proposed sanitary servicing is shown on **Drawing SSP-1** and **Drawing SA-1** in **Appendix G**.

A sump pump is required for sewage discharge from the mechanical room. A backflow preventer is required for the proposed building in accordance with the City of Ottawa Sewer Design Guidelines. Design of internal plumbing and associated mechanical systems for the buildings on site is to be completed with the mechanical engineering design for the buildings.



## 5.0 Stormwater Management and Servicing

### 5.1 Objectives

The goal of this stormwater servicing and stormwater management (SWM) plan is to determine the measures necessary to control the quantity and quality of stormwater released from the proposed development to meet the criteria established during the consultation process with City of Ottawa staff, and to provide sufficient details required for approval.

### 5.2 Stormwater Management (SWM) Criteria

The Stormwater Management (SWM) criteria are established by combining current design practices outlined by the City of Ottawa Sewer Design Guidelines (SDG) (October 2012), review of project pre-consultation notes with the City of Ottawa, and through consultation with City of Ottawa staff. The following summarizes the criteria, with the source of each criterion indicated in brackets:

#### General

- Use of the dual drainage principle (City of Ottawa SDG)
- Wherever feasible and practical, site-level measures should be used to reduce and control the volume and rate of runoff (City of Ottawa SDG)
- Assess impact of 100-year event outlined in the City of Ottawa Sewer Design Guidelines on the major and minor drainage systems (City of Ottawa SDG)

#### Storm Sewer & Inlet Controls

- Discharge for each storm event to be restricted to a 5-year storm event pre-development rate with a maximum pre-development C coefficient of 0.5 (City of Ottawa pre-consultation, **Appendix F**)
- Peak flows generated from events greater than the 5-year and including the 100-year storm must be detained on site (City of Ottawa pre-consultation, **Appendix F**)
- The preferred stormwater system outlet for this site is the 375mm and 450 mm diameter storm sewer within the Sandcastle Drive ROW. (City of Ottawa pre-consultation, **Appendix F**)
- The foundation drainage system is to be independently connected to sewer main unless being pumped with appropriate back up power, sufficient sized pump, and backflow prevention. (City of Ottawa pre-consultation, **Appendix F**)
- $T_c$  should be not less than 10 minutes since IDF curves become unrealistic at less than 10 min (City of Ottawa SDG).

#### Surface Storage & Overland Flow

- Building openings to be a minimum of 0.30 m above the 100-year water level (City of Ottawa SDG)
- Maximum depth of flow under either static or dynamic conditions shall be less than 0.30 m (City of Ottawa SDG)





- Provide adequate emergency overflow conveyance off-site with a minimum vertical clearance of 15 cm between the spill elevation and the ground elevation at the building envelope in the proximity of the flow route or ponding area (City of Ottawa SDG)

### 5.3 Existing Conditions

The existing site (1.19 ha) is dominated by asphalt pavement and the roof of the existing commercial mall with a small patch of soft area, as such the pre-development runoff coefficient of 0.5 was used for the site analysis. From review of the local topography and conditions, an additional 0.02 ha of landscaped area along the south boundary is also considered as part of the contributing drainage area.

The pre-development release rates for the site are determined using the rational method and the drainage characteristics identified above. A time of concentration for the pre-development area of 12 minutes is assigned because of the existing storm sewer connection. The peak pre-development flow rates shown in **Table 5-1** are calculated using the rational method as follows:

$$Q = 2.78 (C)(I)(A)$$

Where:

$Q$  = peak flow rate, L/s

$C$  = site runoff coefficient

$I$  = rainfall intensity, mm/hr (per City of Ottawa IDF curves)

$A$  = drainage area, ha

**Table 5-1: Peak Pre-Development Flow Rates**

Design Storm	Pre-Development Flow Rate (L/s) for C=0.5, A=1.21 ha, tc = 12 min
5-year	159.6
100-year	273.3

### 5.4 Stormwater Management Design

Runoff from the site and the contributing external area is to be collected and managed within the site boundary, excepting areas around the perimeter that cannot be intercepted within the boundary given the proposed development plan and grading constraints.

The site is divided into catchment areas to effectively collect, store, and convey runoff at flow rates not exceeding the target release rate established by consultation with the City of Ottawa (refer to **Drawing SD-1** in **Appendix G** for drainage areas).

Two stormwater cisterns located inside the building underground parking areas are proposed to attenuate peak flows from the site boundary. Site runoff is to be directed to the cisterns through the internal building plumbing systems via roof and ground level drains. Details on the nature of the roof and ground level drains



## 2948 Baseline Road Servicing and Stormwater Management Report

are to be completed with the mechanical engineering design for the buildings and are given no specific design consideration in the analysis included herein. For this servicing report all runoff is considered routed directly to either the cistern associated with Tower 4, or the cistern associated with Tower 5 and 6.

The stormwater cisterns are to be drained at the allowable release rate to monitor manholes prior to the connection to the public storm sewers.

The proposed site plan, drainage areas and proposed storm sewer infrastructure are shown on **Drawing SD-1** and **SSP-1** in **Appendix G**.

### 5.4.1 ALLOWABLE RELEASE RATE

Based on consultation with City of Ottawa staff, the peak post-development discharge from the subject site must be limited to the discharge resulting from the 5-year storm event. As per **Section 5.3**, the maximum pre-development runoff coefficient of  $C=0.5$  is utilized for the site. C coefficient values are increased by 25 percent for the post-development 100-year storm event based on the MTO Drainage Manual recommendations.

The pre-development 5-year release rate for the site of 159.6 L/s, as shown in **Table 5-1**, is apportioned to the two cisterns based on the drainage areas identified on **Drawing SD-1**. The associated target release rate associated with each cistern is shown in **Table 5-2** below.

**Table 5-2: Target Release Rate**

Design Storm	Cistern 1 / Tower 4 Target Release Rate (L/s)	Cistern 2 / Tower 5 & 6 Target Release Rate (L/s)
All Events	51.8	107.8

### 5.4.2 QUANTITY CONTROL: STORAGE REQUIREMENTS

The Modified Rational Method (MRM) is used to assess the flow rate and volume of runoff generated under post-development conditions. The site is divided into catchment areas tributary to each quantity control measure and subject to different discharge controls. **Drawing SD-1** shows the delineated catchment areas. The MRM spreadsheet is included in **Appendix D.1**.

The following assumptions are made in the creation of the storm drainage plan and accompanying MRM spreadsheet:

- Excess run-off that cannot be captured as surface storage due to grading constraints is to sheet flow uncontrolled to the adjacent roadways (areas UNC-1 to UNC-6).
- Stormwater cisterns equipped with mechanical pump to attenuate peak flows from the cisterns will be used to manage stormwater flows from the site.



**5.4.2.1 Uncontrolled Areas**

Uncontrolled areas represent drainage areas that cannot be graded to enter the site/building drainage collection system. As such, they are to sheet drain off the site to the adjacent roadways (see **Drawing SD-1**).

The following table lists the 5-year and 100-year peak flow rates from the uncontrolled runoff areas.

**Table 5-3: Peak Uncontrolled 5-Year and 100-Year Run-Off**

Area ID	Area (ha)	5-Year Uncontrolled Peak Flow (L/s)	100-Year Uncontrolled Peak Flow (L/s)
<b>Cistern 1 / Tower 4</b>			
UNC-1	0.02	0.9	1.9
UNC-2	0.02	3.9	7.4
UNC-6	0.01	2.0	4.4
<b>Total</b>	<b>0.05</b>	<b>6.8</b>	<b>13.7</b>
<b>Cistern 2 / Tower 5 &amp; 6</b>			
UNC-3	0.09	16.1	34.5
UNC-4	0.03	7.1	14.0
UNC-5	0.06	14.6	29.5
<b>Total</b>	<b>0.18</b>	<b>37.8</b>	<b>77.9</b>

The 100-year uncontrolled peak flow is subtracted from the target release rate to establish the allowable discharge rate from each cistern. The related calculations are included with the MRM spreadsheet in **Appendix D.1**.

**5.4.2.2 Stormwater Cisterns**

The allowable design flow rate and volume of stormwater storage required for each cistern system is summarized in

**Table 5-4.**

**Table 5-4: Proposed Cistern Sizing for 5-Year and 100-Year Storage Requirement**

Cistern	Storm Return Period	Area IDs	Controlled Drainage Area (ha)	Q <sub>release</sub> (L/s)	V <sub>required</sub> (m <sup>3</sup> )	Total V <sub>required</sub> (m <sup>3</sup> )
1	5-Year	CIST 1-1 to 1-7, EXT-1	0.35	29.8	19	325
	100-Year				74	
2	5-Year	CIST 2-1 to 2-9	0.64	38.2	84	



	100-Year				251	
--	----------	--	--	--	-----	--

**5.4.2.3 Results**

The proposed stormwater management plan provides adequate attenuation to meet the target release rate for the 5-year and 100-year storm events as shown in **Table 5-5** below.

**Table 5-5: Estimated Post-Development Discharge**

Area Type	5-Year (L/s)	100-Year (L/s)	Target (L/s)
Uncontrolled	20.9	91.6	<b>159.6</b>
Controlled Areas/Cistern Release	68.0	68.0	
<b>Total Flow to Sewer</b>	<b>88.9</b>	<b>159.6</b>	

Flows from the uncontrolled areas have been considered in the overall release rate for the site and the cistern storage will allow for the attenuation of peak flows to meet the allowable target release rate. The modified rational method calculations have been provided in **Appendix D.1** and the storm design sheet provided in **Appendix D.2**.

**5.5 Proposed Stormwater Servicing**

The site will be serviced by two proposed 300 mm diameter storm sewer connections, one supporting Tower 4 and one supporting Tower 5 and 6. The storm sewer connections route stormwater discharge from the cisterns and connect to the existing 375mm and 450 mm diameter storm sewers on Sandcastle Drive. The proposed storm sewer connections are illustrated on **Drawing SSP-1** and **Drawing SD-1** in **Appendix G**. A storm sewer design sheet is included in **Appendix D.2**.

The storm sewer connections are to be complete with full port backwater valve as per City standard S14.1.

Footing drainage is to be independent of the internal stormwater cistern quantity control system while sharing the same outlet. The mechanical design for the weeping tile system is anticipated to include dedicated storm pits and duplex pumps to pump the weeping tile drainage to the storm main downstream of the cistern.

The site stormwater collection systems, cistern locations, cistern discharge systems, and footing drainage systems will be developed as per the building mechanical and structural engineering designs.



## 6.0 Site Grading

The proposed site of approximately 1.19 ha consists of an existing commercial strip mall and asphalt parking area with small patches of grassed area. The topography across the site generally slopes from the middle towards the Sandcastle Drive ROW at the west and the mixed-use development site along the east boundary.

A grading plan (see **Drawing GP-1** in **Appendix G**) is provided to support the stormwater management requirements and emergency overland flow routes, adhere to any grade raise restrictions for the site, and provide for minimum cover requirements for water, sanitary, and storm servicing systems where possible.

The proposed grading plan provides adequate emergency overland flow routes and generally maintains the existing drainage patterns within the adjacent public rights of way. As identified on the drawings in **Appendix F** various curbs and sidewalks will be removed and replaced with full height barrier curbs and sidewalks in accordance with Ottawa standards.



## 7.0 Utilities

Overhead (OH) hydro-wires run parallel to the north property line along the south side of Baseline Road, with branches servicing the adjacent sites in intervals. All utilities within the work area will require relocation during construction. The existing utility poles within the public right of way are to be protected during construction.

As the site is surrounded by existing residential and commercial development, Hydro Ottawa, Bell, Rogers, and Enbridge servicing is readily available through existing infrastructure to service this site. The exact size, location, and routing of utilities will be finalized after design circulation. Existing overhead wires and utility plants may need to be temporarily moved/reconfigured to allow sufficient clearance for the movement of heavy machinery required for construction. The relocation of existing utilities will be coordinated with the individual utility providers upon design circulation.



## 8.0 Approvals

The proposed development lies on a private site under singular ownership, and as the storm discharge drains to an existing storm sewer outlet, therefore, the site will not require an Environmental Compliance Approval (ECA) from the Ministry of the Environment, Conservation and Parks (MECP) under O.Reg. 525/98.

For ground or surface water volumes being pumped during the construction phase, typically between 50,000 to 400,000 L/day, it is required to register on the Environmental Activity and Sector Registry (EASR). It is possible that groundwater may be encountered during the foundation excavation on this site. A minimum of two to four weeks should be allotted for completion of the EASR registration and the preparation of the Water Taking and Discharge Plan by a Qualified Person as stipulated under O.Reg. 63/16. An MECP Permit to Take Water (PTTW), which is required for dewatering volumes exceeding 400,000L/day, is not anticipated for the site.



## 9.0 Erosion and Sediment Control During Construction

To protect downstream water quality and prevent sediment build-up in catch basins and storm sewers, erosion and sediment control measures must be implemented during construction. The following recommendations will be included in the contract documents and communicated to the Contractor.

1. Implement best management practices to provide appropriate protection of the existing and proposed drainage system and the receiving water course(s).
2. Limit the extent of the exposed soils at any given time.
3. Re-vegetate exposed areas as soon as possible.
4. Minimize the area to be cleared and grubbed.
5. Protect exposed slopes with geotextiles, geogrid, or synthetic mulches.
6. Install silt barriers/fencing around the perimeter of the site as indicated in **Drawing ECDS-1 in Appendix G** to prevent the migration of sediment offsite.
7. Install trackout control mats (mud mats) at the entrance/egress to prevent migration of sediment into the public ROW.
8. Provide sediment traps and basins during dewatering works.
9. Install sediment traps (such as SiltSack® by Terrafix) between catch basins and frames.
10. Schedule the construction works at times which avoid flooding due to seasonal rains.

The Contractor will also be required to complete inspections and guarantee the proper performance of their erosion and sediment control measures at least after every rainfall. The inspections are to include:

- Verification that water is not flowing under silt barriers.
- Cleaning and changing the sediment traps placed on catch basins.

Refer to **Drawing ECDS-1 in Appendix G** for the proposed location of silt fences, sediment traps, and other erosion control measures.





## 10.0 Geotechnical Investigation

A geotechnical investigation report prepared by Paterson Group on May 8, 2023 provides an assessment of the subsurface conditions found at the site. A previous revision prepared on March 24, 2022. Ten (10) boreholes, numbered BH 1-22 to BH 10-22, are advanced to a maximum depth of 12.8 metres below the existing ground surface in the investigation carried out on February 8-11 and 14, 2022. The information obtained from the field investigation guides the detailed design of the site and supports the identification of development constraints.

The subsurface profile encountered at the test hole locations are characterized primarily by a layer of flexible asphalt pavement and granular crushed stones with silty clay or sand, underlain by firm to very stiff brown silty clay crust, followed by a deep, stiff to very stiff grey silty clay deposit. A layer of glacial till, consisting of sand and gravel within a silty clay soil matrix is encountered at BH 5-22 and BH 10-22.

From available geological mapping, the bedrock is part of the Oxford formation with overburden thickness expected to range from 10 m to 15 m. Long-term groundwater levels are expected to be at 4 metres to 5 metres depth, though as groundwater levels are subject to seasonal fluctuations, they could vary at the time of construction.

Based on Paterson Group’s recommendations, the site is suitable for the proposed development. It is recommended that the main tower super structures be founded on piles while surrounding levels of underground parking be founded on conventional spread footings placed on an undisturbed stiff silty clay bearing surface. Due to the presence of the silty clay deposit, grading is subject to a permissible grade raise restriction of 2.0 m.

The recommended rigid pavement structure is further presented in

**Table 10-1** below.

**Table 10-1: Recommended Pavement Structure**

<b>Material</b>	<b>Car-only Parking Areas</b>	<b>Access Lanes, Ramp and Heavy Truck Parking Areas</b>
Wear Course –Superpave 12.5 Asphaltic Concrete	50 mm	40 mm
Binder Course – Superpave 19.0 Asphaltic Concrete	-	50 mm
BASE – OPSS Granular ‘A’ Base	150 mm	150 mm
SUBBASE – OPSS Granular ‘B’ Type II	300 mm	450 mm

Refer to the full geotechnical report attached in Error! Reference source not found. for further details.



## 11.0 Conclusions

### 11.1 Water Servicing

Based on the supplied boundary conditions for existing watermains and calculated domestic and fire flow demands for the subject site, a new 200mm connection between the adjacent 200mm watermains along the site boundary to the east and on Sandcastle Drive provides sufficient capacity to sustain both the required domestic and emergency fire flow demands for the development. The existing private fire hydrant on site is to be relocated and a new one is proposed to further support the provision of fire flows at the site.

To facilitate the building construction, the existing 200mm private watermain through the site is to be removed and then replaced with a 200mm connection passing through the building. This maintains the function of the existing watermain as a part of the water servicing system. The details of the watermain replacement through the building are to be included with the mechanical engineering design for the buildings.

Suitable water supply and pressure conditions for the water demand and building sprinkler system will be established by the building mechanical engineering design.

### 11.2 Sanitary Servicing

Existing connections are to be abandoned and full port backwater valves installed on the proposed sanitary service within the site to prevent any surcharge from the downstream sewer main from impacting the proposed property.

The proposed sanitary sewer services are 200 mm diameter sanitary service laterals, with monitor manholes, connected to the existing 250 mm diameter sanitary sewer in Sandcastle Drive.

A sump pump is required for sewage discharge from the mechanical room. A backflow preventer is required for the proposed building in accordance with the City of Ottawa Sewer Design Guidelines. Design of internal plumbing and associated mechanical systems for the buildings on site is to be completed with the mechanical engineering design for the buildings.

### 11.3 Stormwater Servicing and Management

Runoff from the site and the contributing external area is to be collected and managed within the site boundary, excepting areas around the perimeter that cannot be intercepted within the boundary given the proposed development plan and grading constraints.

Two stormwater cisterns located inside the building underground parking areas are proposed to attenuate peak flows from the site boundary. Site runoff is to be directed to the cisterns through the internal building plumbing systems via roof and ground level drains. Details on the nature of the roof and ground level drains are to be completed with the mechanical engineering design for the buildings and are given no specific



design consideration in the analysis included herein. For this servicing report all runoff is considered routed directly to either the cistern associated with Tower 4, or the cistern associated with Tower 5 and 6.

The stormwater cisterns are to be drained at the allowable release rate to monitor manholes prior to the connection to the public storm sewers. The site stormwater collection systems, cistern locations, cistern discharge systems, and footing drainage systems will be developed as per the building mechanical and structural engineering designs.

The site will be serviced by two proposed 300 mm diameter storm sewer connections, one supporting Tower 4 and one supporting Tower 5 and 6. The storm sewer connections route stormwater discharge from the cisterns and connect to the existing 375mm and 450 mm diameter storm sewers on Sandcastle Drive.

### 11.4 Grading

The proposed grading plan provides adequate emergency overland flow routes and generally maintains the existing drainage patterns within the adjacent public rights of way.

### 11.5 Erosion and Sediment Control During Construction

Erosion and sediment control measures and best management practices outlined in this report and included in the drawing set, are to be implemented during construction to reduce the impact on adjacent properties, the public ROW, and existing facilities.

### 11.6 Geotechnical Investigation

Based on the geotechnical investigation, the site is considered suitable for the proposed building, and it is recommended that the main tower super structures be founded on piles while surrounding levels of underground parking be founded on conventional spread footings placed on an undisturbed stiff silty clay bearing surface. Due to the presence of the silty clay deposit, grading is subject to a permissible grade raise restriction of 2.0 m.

### 11.7 Utilities

The site is situated within an established neighbourhood, hence existing utility infrastructure is readily available to service the proposed development. Overhead wires along all boundaries of the site need to be accommodated during construction. It is anticipated that existing infrastructure is sufficient to provide a means of distribution for the proposed site. Exact size, location and routing of utilities is to be finalized after design circulation.

### 11.8 Approvals

This site is not subject to the Ministry of the Environment, Conservation and Parks (MECP) Environmental Compliance Approval (ECA) process under O.Reg. 525/98. For the expected dewatering needs of 50,000 to 400,000 L/day, registration on the MECP's Environmental Activity and Sector Registry (EASR) is



## 2948 Baseline Road Servicing and Stormwater Management Report

required. A Permit to Take Water for dewatering needs exceeding 400,000 L/day, is not anticipated for this site.



# APPENDICES

# Appendix A Site Plan



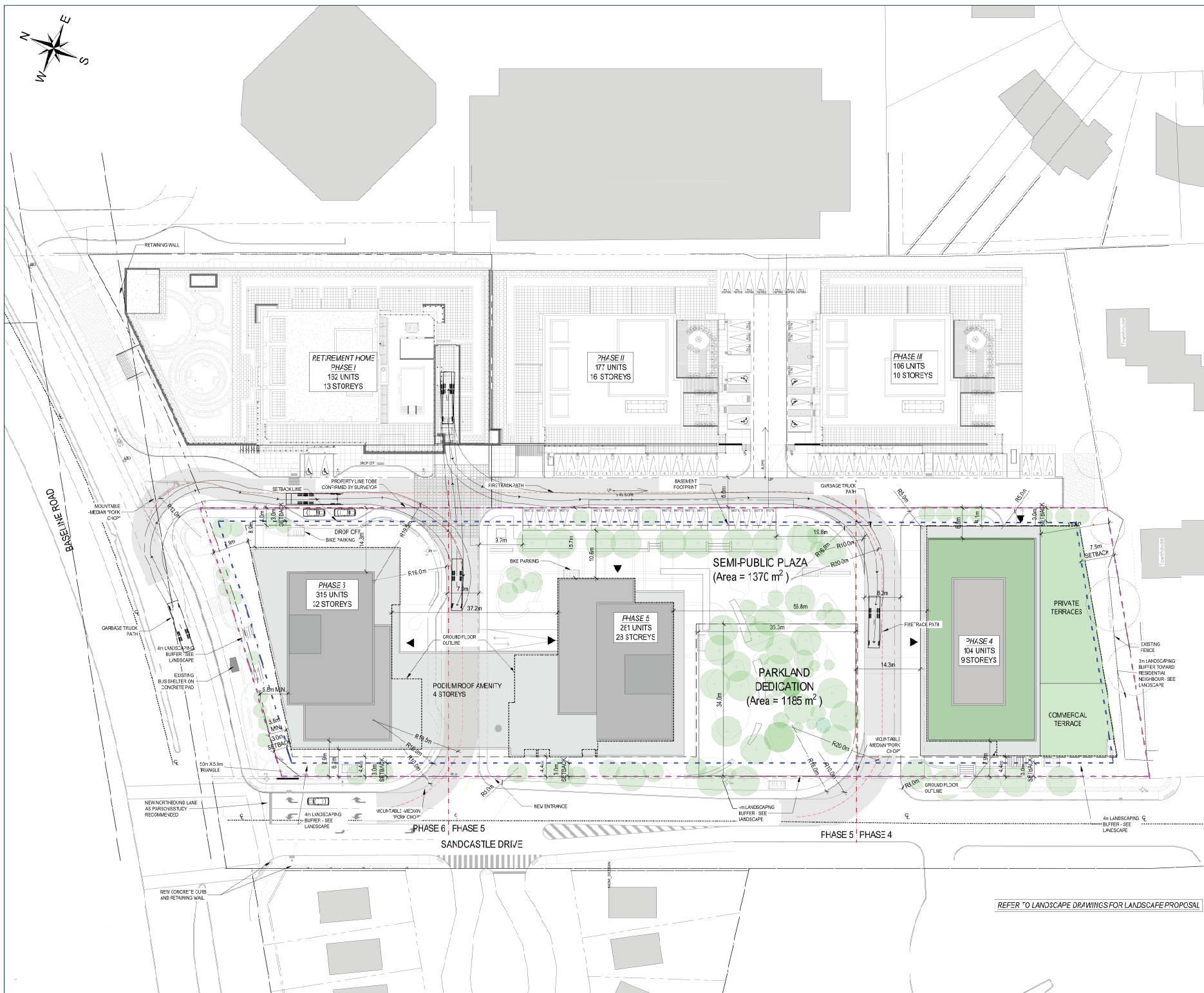

**NOTES GENERALES - General Notes**

1. Les dimensions d'architecture sont le principe de base de toutes les dimensions de la structure. Les dimensions de la structure sont indiquées en rouge.
2. Les dimensions d'architecture sont le principe de base de toutes les dimensions de la structure. Les dimensions de la structure sont indiquées en rouge.
3. Les dimensions d'architecture sont le principe de base de toutes les dimensions de la structure. Les dimensions de la structure sont indiquées en rouge.
4. Les dimensions d'architecture sont le principe de base de toutes les dimensions de la structure. Les dimensions de la structure sont indiquées en rouge.

ARCHITECTURE: **NEUF architects**  
 1111 Avenue de la Commune, Ottawa, Ontario K1R 1S1  
 TEL: 613 745 1111

PLANNING: **FOTENN Planning & Urban Design**  
 1111 Avenue de la Commune, Ottawa, Ontario K1R 1S1  
 TEL: 613 745 1111

ARCHITECTURE DE PAYSAGE: **SITIFORM**  
 1111 Avenue de la Commune, Ottawa, Ontario K1R 1S1  
 TEL: 613 745 1111

CLIENT: **STANTEC**  
 300, 1000 Avenue de la Commune, Ottawa, Ontario K1R 1S1  
 TEL: 613 745 1111

STRUCTURE: **Structure**



CLIENT: **BRIGIL**  
 1111 Avenue de la Commune, Ottawa, Ontario K1R 1S1  
 TEL: 613 745 1111

PROJET: **BASELINE 456**

EMPLACEMENT: **Ottawa**

NO. REVISION: 00  
 DATE: 2023-10-22

**Preliminary  
 Do NOT USE FOR  
 CONSTRUCTION**

DATE: 23.05.18  
 ECHELLE: 1:250

**SITE PLAN**

REVISION: **A100**

REFER TO LANDSCAPE DRAWINGS FOR LANDSCAPE PROPOSAL

## Appendix B Water Demand

### B.1 Domestic Water Demand





**2948 Baseline Road (Brill Development) - Domestic Water Demand Estimates**

Based on conceptual development plans from Neuf Architect(e)s (2023/04/11)

Ottawa Design Guidelines - Water Distribution

Unit Type	Population (ppu)
Studio	1.4
1 Bedroom	1.4
2 Bedroom	2.1
3 Bedroom	3.1
Townhouse	2.7

Development Block/Area ID	Commercial/Amenity Area (m <sup>2</sup> )	Number of Residential Units	Population	Daily Demand Rate (L/cap/day or L/ha/d)	Avg. Day Demand <sup>1,2</sup>		Max. Day Demand <sup>1,2</sup>		Peak Hour Demand <sup>1,2</sup>	
					(L/min)	(L/s)	(L/min)	(L/s)	(L/min)	(L/s)
<b>Tower 4 (9 Storeys)</b>										
Studio	-	52	73	280	14.2	0.24	35.4	0.59	77.9	1.30
1 Bedroom	-	23	32	280	6.3	0.10	15.7	0.26	34.4	0.57
2 Bedroom	-	20	42	280	8.2	0.14	20.4	0.34	44.9	0.75
3 Bedroom	-	9	28	280	5.4	0.09	13.6	0.23	29.8	0.50
Commercial Area	426	-	-	28000	8.3	0.14	12.4	0.21	22.4	0.37
<b>Tower 5 (28 Storeys)</b>										
Studio	-	20	28	280	5.4	0.09	13.6	0.23	29.9	0.50
1 Bedroom	-	147	206	280	40.0	0.67	100.0	1.67	220.1	3.67
2 Bedroom	-	96	202	280	39.2	0.65	98.0	1.63	215.6	3.59
3 Bedroom	-	15	47	280	9.0	0.15	22.6	0.38	49.7	0.83
Townhouse	-	3	8	280	1.6	0.03	3.9	0.07	8.7	0.14
Commercial Area	118	-	-	28000	2.3	0.04	3.4	0.06	6.2	0.10
<b>Tower 6 (32 Storeys)</b>										
Studio	-	52	73	280	14.2	0.24	35.4	0.59	77.9	1.30
1 Bedroom	-	124	174	280	33.8	0.56	84.4	1.41	185.7	3.09
2 Bedroom	-	123	258	280	50.2	0.84	125.6	2.09	276.2	4.60
3 Bedroom	-	16	50	280	9.6	0.16	24.1	0.40	53.0	0.88
Commercial Area	971	-	-	28000	18.9	0.31	28.3	0.47	51.0	0.85
<b>Total Site :</b>	<b>1515</b>	<b>700</b>	<b>1219</b>	<b>-</b>	<b>266.5</b>	<b>4.44</b>	<b>636.9</b>	<b>10.61</b>	<b>1383.4</b>	<b>23.06</b>

1 Water demand criteria used to estimate peak demand rates for residential areas are as follows:

maximum daily demand rate = 2.5 x average day demand rate  
 peak hour demand rate = 2.2 x maximum day demand rate

2 Water demand criteria used to estimate peak demand rates for commercial/amenity/lobby areas are as follows:

maximum daily demand rate = 1.5 x average day demand rate  
 peak hour demand rate = 1.8 x maximum day demand rate

3 Population density for all residential units based on an population densities provided in Table 4.1 - Per Unit Populations of the City of Ottawa Water Distribution Design Guidelines (July 2010).

## B.2 Fire Flow Demands (FUS 2020)





FUS Fire Flow Calculation Sheet - 2020 FUS Guidelines

Stantec Project #: 160401536  
 Project Name: 2946 Baseline Road  
 Date: 5/25/2023  
 Fire Flow Calculation #: 1  
 Description: Tower 4

Notes: 9-Storey Mixed-Use, sprinklered with floor assemblies / load bearing walls as 1hr rated assemblies per OBC 3.2.2.52

Step	Task	Notes	Value Used	Req'd Fire Flow (L/min)						
1	Determine Type of Construction	Type II - Noncombustible Construction / Type IV-A - Mass Timber Construction	0.8	-						
2	Determine Effective Floor Area	Sum of Largest Floor + 25% of Two Additional Floors	Vertical Openings Protected?	YES						
		1965    901    1411    1411    1411    1411    1411    1411	2543	-						
3	Determine Required Fire Flow	(F = 220 x C x A <sup>1/2</sup> ). Round to nearest 1000 L/min	-	9000						
4	Determine Occupancy Charge	Limited Combustible	-15%	7650						
5	Determine Sprinkler Reduction	Conforms to NFPA 13	-30%	-3825						
		Standard Water Supply	-10%							
		Fully Supervised	-10%							
		% Coverage of Sprinkler System	100%							
6	Determine Increase for Exposures (Max. 75%)	Direction	Exposure Distance (m)	Exposed Length (m)	Exposed Height (Stories)	Length-Height Factor (m x stories)	Construction of Adjacent Wall	Firewall / Sprinklered ?	-	-
		North	> 30	38	28	> 100	Type I-II - Protected Openings	YES	0%	612
		East	10.1 to 20	46	10	> 100	Type III-IV - Protected Openings	YES	0%	
		South	20.1 to 30	45	2	81-100	Type V	NO	8%	
		West	> 30	40	11	> 100	Type I-II - Unprotected Openings	NO	0%	
7	Determine Final Required Fire Flow	Total Required Fire Flow in L/min, Rounded to Nearest 1000L/min			4000					
		Total Required Fire Flow in L/s			66.7					
		Required Duration of Fire Flow (hrs)			1.50					
		Required Volume of Fire Flow (m <sup>3</sup> )			360					



FUS Fire Flow Calculation Sheet - 2020 FUS Guidelines

Stantec Project #: 160401536  
 Project Name: 2946 Baseline Road  
 Date: 5/25/2023  
 Fire Flow Calculation #: 2  
 Description: Tower 5

Notes: 28-Storey Mixed-Use, sprinklered with floor assemblies / load bearing walls as 1hr rated assemblies per OBC 3.2.2.52

Step	Task	Notes	Value Used	Req'd Fire Flow (L/min)						
1	Determine Type of Construction	Type II - Noncombustible Construction / Type IV-A - Mass Timber Construction	0.8	-						
2	Determine Effective Floor Area	Sum of Largest Floor + 25% of Two Additional Floors		Vertical Openings Protected?						
		1662   1662   1662   1662   1098   849   849   849	2493	YES						
3	Determine Required Fire Flow	(F = 220 x C x A <sup>1/2</sup> ). Round to nearest 1000 L/min	-	9000						
4	Determine Occupancy Charge	Limited Combustible	-15%	7650						
5	Determine Sprinkler Reduction	Conforms to NFPA 13	-30%	-3825						
		Standard Water Supply	-10%							
		Fully Supervised	-10%							
		% Coverage of Sprinkler System	100%							
6	Determine Increase for Exposures (Max. 75%)	Direction	Exposure Distance (m)	Exposed Length (m)	Exposed Height (Stories)	Length-Height Factor (m x stories)	Construction of Adjacent Wall	Firewall / Sprinklered ?	-	-
		North	20.1 to 30	44	32	> 100	Type I-II - Protected Openings	YES	0%	1148
		East	10.1 to 20	50	16	> 100	Type I-II - Protected Openings	YES	0%	
		South	20.1 to 30	52	9	> 100	Type I-II - Protected Openings	YES	0%	
		West	10.1 to 20	40	3	> 100	Type V	NO	15%	
7	Determine Final Required Fire Flow	Total Required Fire Flow in L/min, Rounded to Nearest 1000L/min			5000					
		Total Required Fire Flow in L/s			83.3					
		Required Duration of Fire Flow (hrs)			1.75					
		Required Volume of Fire Flow (m <sup>3</sup> )			525					



FUS Fire Flow Calculation Sheet - 2020 FUS Guidelines

Stantec Project #: 160401676  
 Project Name: 2948 Baseline Road  
 Date: 5/25/2023  
 Fire Flow Calculation #: 3  
 Description: Tower 6

Notes: 32-Storey Mixed-Use, sprinklered with floor assemblies / load bearing walls as 1hr rated assemblies per OBC 3.2.2.52

Step	Task	Notes	Value Used	Req'd Fire Flow (L/min)						
1	Determine Type of Construction	Type II - Noncombustible Construction / Type IV-A - Mass Timber Construction	0.8	-						
2	Determine Effective Floor Area	Sum of Largest Floor + 25% of Two Additional Floors	Vertical Openings Protected?	YES	-					
		1365    1555    1555    1555    1555    811    811    811	2142.5	-						
3	Determine Required Fire Flow	(F = 220 x C x A <sup>1/2</sup> ). Round to nearest 1000 L/min	-	8000						
4	Determine Occupancy Charge	Limited Combustible	-15%	6800						
5	Determine Sprinkler Reduction	Conforms to NFPA 13	-30%	-3400						
		Standard Water Supply	-10%							
		Fully Supervised	-10%							
		% Coverage of Sprinkler System	100%							
6	Determine Increase for Exposures (Max. 75%)	Direction	Exposure Distance (m)	Exposed Length (m)	Exposed Height (Stories)	Length-Height Factor (m x stories)	Construction of Adjacent Wall	Firewall / Sprinklered ?	-	-
		North	> 30	43	2	81-100	Type V	NO	0%	0
		East	20.1 to 30	40	13	> 100	Type I-II - Protected Openings	YES	0%	
		South	20.1 to 30	20	28	> 100	Type I-II - Protected Openings	YES	0%	
		West	> 30	21	3	61-80	Type V	NO	0%	
7	Determine Final Required Fire Flow	Total Required Fire Flow in L/min, Rounded to Nearest 1000L/min			3000					
		Total Required Fire Flow in L/s			50.0					
		Required Duration of Fire Flow (hrs)			1.25					
		Required Volume of Fire Flow (m <sup>3</sup> )			225					

## B.3 Boundary Conditions



**From:** [Afzalan, Bahar](#)  
**To:** [Rasool, Rubina](#); [Mott, Peter](#)  
**Subject:** RE: Boundary Conditions Request - 2948 Baseline Road  
**Date:** Wednesday, May 10, 2023 3:35:25 PM  
**Attachments:** [2948 Baseline Road May 2023.pdf](#)

---

Hi Peter,

The following are boundary conditions, HGL, for hydraulic analysis at 2948 Baseline Road (zone 2W2C) with assumed to be connected to the 203 mm watermain on Sandcastle Drive and the 203 mm on Baseline Road (see attached PDF for location).

All Connections:

Minimum HGL: 126.7 m

Maximum HGL: 133.0 m

Max Day + FireFlow (83 L/s): 127.2 m (Connection 1), 127.6 m (Connection 2), 129.6 m (Connection 3)

These are for current conditions and are based on computer model simulation.

*Disclaimer: The boundary condition information is based on current operation of the city water distribution system. The computer model simulation is based on the best information available at the time. The operation of the water distribution system can change on a regular basis, resulting in a variation in boundary conditions. The physical properties of watermains deteriorate over time, as such must be assumed in the absence of actual field test data. The variation in physical watermain properties can therefore alter the results of the computer model simulation.*

**Bahar Afzalan**

Engineering Intern  
City of Ottawa  
Development Review – West Branch  
Planning, Real Estate and Economic Development Department  
110 Laurier Avenue West Ottawa, ON, K1P 1J1  
613.580.2424 ext. 22518, [bahar.afzalan@ottawa.ca](mailto:bahar.afzalan@ottawa.ca)

---

**From:** Rasool, Rubina <[Rubina.Rasool@ottawa.ca](mailto:Rubina.Rasool@ottawa.ca)>  
**Sent:** May 04, 2023 12:51 PM  
**To:** Mott, Peter <[Peter.Mott@stantec.com](mailto:Peter.Mott@stantec.com)>  
**Cc:** Afzalan, Bahar <[bahar.afzalan@ottawa.ca](mailto:bahar.afzalan@ottawa.ca)>  
**Subject:** RE: Boundary Conditions Request - 2948 Baseline Road

Hi Peter,

I have forwarded the water boundary conditions. Please allow for 5-10 business days for the results.

Thanks,

**Rubina**

-----  
**Rubina Rasool**

Project Manager  
Planning, Infrastructure and Economic Development Department  
Development Review – East Branch  
City of Ottawa  
110 Laurier Avenue West Ottawa, ON K1P 1J1  
[rubina.rasool@ottawa.ca](mailto:rubina.rasool@ottawa.ca)

---

**From:** Mott, Peter <[Peter.Mott@stantec.com](mailto:Peter.Mott@stantec.com)>

**Sent:** April 25, 2023 11:55 AM

**To:** Stern, Lisa <[lisa.stern@ottawa.ca](mailto:lisa.stern@ottawa.ca)>

**Cc:** Sharp, Mike <[Mike.Sharp@stantec.com](mailto:Mike.Sharp@stantec.com)>; Kilborn, Kris <[kris.kilborn@stantec.com](mailto:kris.kilborn@stantec.com)>

**Subject:** RE: Boundary Conditions Request - 2948 Baseline Road

**CAUTION: This email originated from an External Sender. Please do not click links or open attachments unless you recognize the source.**

**ATTENTION : Ce courriel provient d'un expéditeur externe. Ne cliquez sur aucun lien et n'ouvrez pas de pièce jointe, excepté si vous connaissez l'expéditeur.**

Hi Lisa – Just wanted to follow up on my email below and confirm that the information has been forwarded to the respective Engineering PM for the project. If you could confirm it would be much appreciated as we are trying to develop a timeline for our SPA submission. If you have any questions or comments, please let me know at your earliest convenience. Thank you.

Best,

**Peter Mott** EIT

Engineering Intern, Community Development

Mobile: +1 (613) 897-0445

Teams: +1 (613) 724-4370

[Peter.Mott@stantec.com](mailto:Peter.Mott@stantec.com)

Stantec

300 - 1331 Clyde Avenue

Ottawa ON K2C 3G4



The content of this email is the confidential property of Stantec and should not be copied, modified, retransmitted, or used for any purpose except with Stantec's written authorization. If you are not the intended recipient, please delete all copies and notify us immediately.

---

**From:** Mott, Peter

**Sent:** Wednesday, April 12, 2023 12:02 PM



**To:** [lisa.stern@ottawa.ca](mailto:lisa.stern@ottawa.ca)

**Cc:** Sharp, Mike <[Mike.Sharp@stantec.com](mailto:Mike.Sharp@stantec.com)>; Kilborn, Kris <[kris.kilborn@stantec.com](mailto:kris.kilborn@stantec.com)>

**Subject:** Boundary Conditions Request - 2948 Baseline Road

Hello Lisa,

I just sent this request to Jessica Valic who was previously listed as the Engineering PM for this project in the pre-consultation notes, however, I received a bounce back email... Hoping you could forward the below request to the new Engineering PM for the project or provide me with their contact information. Thanks!

I would like to request the hydraulic boundary conditions for the proposed 2948 Baseline Road Development (Zone 2W2C). Please find attached the key map showing the location of the proposed development with the identified connection locations, domestic water demand calculations, and fire flow calculations.

A summary of the proposed site is provided below:

We anticipate three (3) connections to service the development, two of which are existing and one new connection: two to the existing watermain within Sandcastle Drive and one from the watermain stub within 2944 Baseline Road. The following connections are expected for servicing:

- Connection to the existing 200 mm watermain on Sandcastle Drive (Existing).
- Connection to the existing 200 mm watermain on Sandcastle Drive (New Connection).
- Connection to the existing 200 mm watermain stub within 2944 Baseline Road, or connection to the existing 1220 mm watermain within Baseline Road where there is already an existing connection.

**\*Please verify if hydraulic modelling information is available for the stub at 2944 Baseline Road, otherwise a BC at the 1220 mm diameter watermain fronting the proposed development within Baseline Road will be required.**

**For the purpose of the boundary conditions request, may you please provide us with the boundary conditions for the following servicing options:**

i. Watermain connections to the above listed connections; assuming a fire flow requirement of **5,000 L/min (83 L/s)** for the site in addition to the domestic water demands provided below.

- The intended land use is a combination of residential and commercial/mixed use per the summary provided in the Domestic Demands spreadsheet.
- Estimated fire flow demand per the FUS methodology: 5,000 L/min (83 L/s) for the worst-case scenario (Tower 5)
- Domestic water demands for the entire development:
  - **Average day: 266.5 L/min (4.44 L/s)**
  - **Maximum day: 636.9 L/min (10.61 L/s)**
  - **Peak hour: 1383.4 L/min (23.06 L/s)**

Thank you for your time and please contact me at your earliest convenience if any additional information or clarification is required.

Best regards,

**Peter Mott** EIT

Engineering Intern, Community Development

Mobile: +1 (613) 897-0445

Teams: +1 (613) 724-4370

[Peter.Mott@stantec.com](mailto:Peter.Mott@stantec.com)

Stantec

300 - 1331 Clyde Avenue

Ottawa ON K2C 3G4



This e-mail originates from the City of Ottawa e-mail system. Any distribution, use or copying of this e-mail or the information it contains by other than the intended recipient(s) is unauthorized. Thank you.

Le présent courriel a été expédié par le système de courriels de la Ville d'Ottawa. Toute distribution, utilisation ou reproduction du courriel ou des renseignements qui s'y trouvent par une personne autre que son destinataire prévu est interdite. Je vous remercie de votre collaboration.

**Caution:** This email originated from outside of Stantec. Please take extra precaution.

**Attention:** Ce courriel provient de l'extérieur de Stantec. Veuillez prendre des précautions supplémentaires.

**Atención:** Este correo electrónico proviene de fuera de Stantec. Por favor, tome precauciones adicionales.

# Boundary Conditions for 2948 Baseline Road May 2023

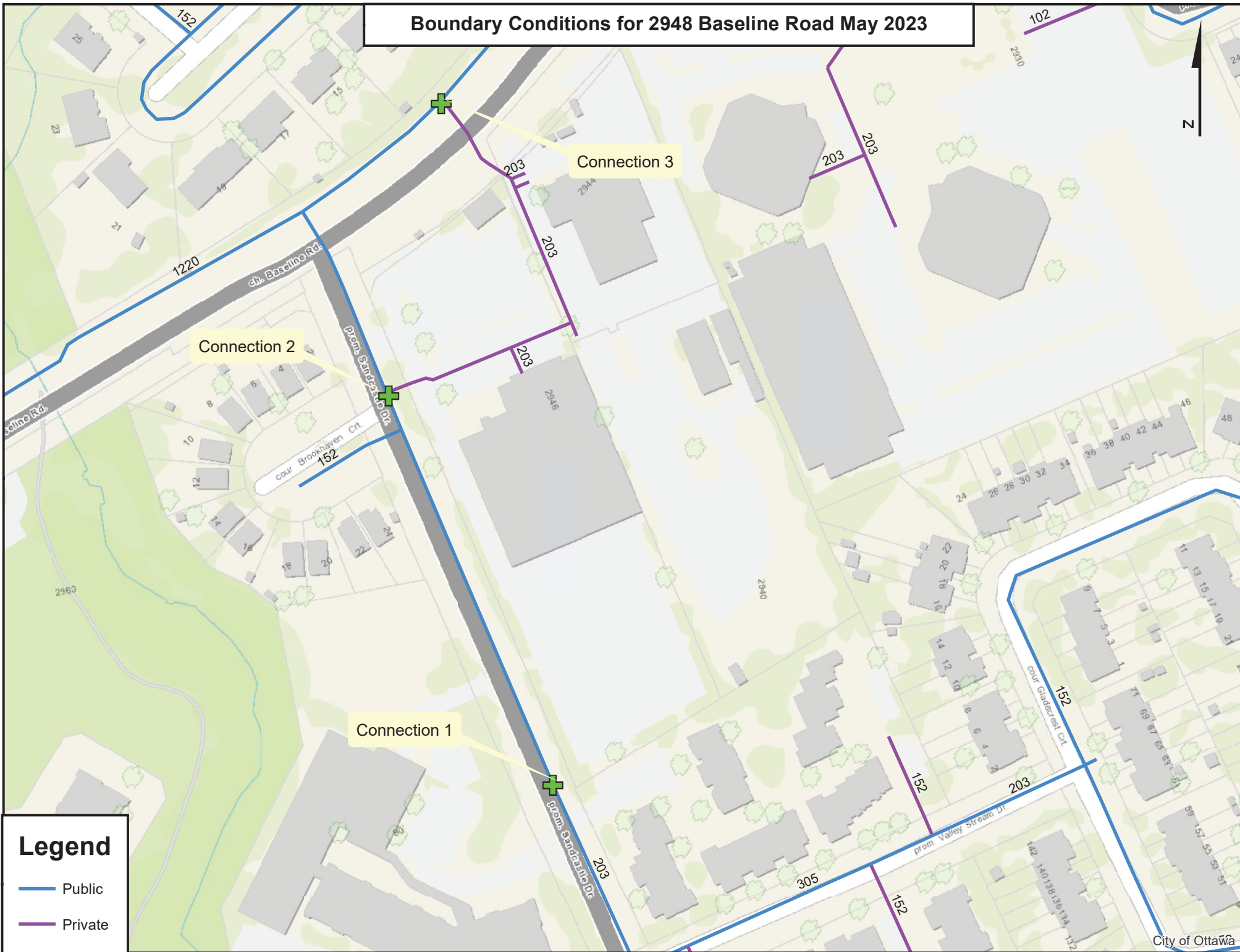

**Legend**

- Public
- Private

## B.4 Fire Hydrant Coverage Calculations



	Project:	2948 Baseline Road	160401676	
	<b>TABLE 1: FIRE HYDRANT COVERAGE TABLE</b>			
	Revision:	0	Prepared By:	MW
	Revision Date:	2022-04-22	Checked By:	PM

Description	Hydrants <sup>1</sup>				Total Available Fire Flow (L/min)	Total Required Fire Flow <sup>2</sup> (L/min)
	HYD-01	HYD-02	HYD-03	HYD-04		
<b>Tower 4 - 2948 Baseline Road</b>						
Distance from building (m)	73.0	35.0	142.0	135.0	-	-
Direction from building	North	West	West	North	-	-
Maximum fire flow capacity <sup>3</sup> (L/min)	5,678	5,678	3,785	3,785	<b>18,926</b>	4,000

NFPA 1 Table 18.5.4.3	
Distance to Building (m)	Maximum Capacity (L/min)
≤ 76	5,678
> 76 and ≤ 152	3,785
> 152 and ≤ 305	2,839

Notes:

- Hydrant locations as per GeoOttawa accessed April 22, 2022. Refer to fire hydrant coverage sketch (Figure 2).
- See FUS (2020) Calculations, Appendix A.2 for fire flow requirements.
- See NFPA 1 Table 18.5.4.3 for maximum fire flow capacity of hydrants by distance to building.

	Project:	2948 Baseline Road	160401676	
	<b>TABLE 1: FIRE HYDRANT COVERAGE TABLE</b>			
	Revision:	0	Prepared By:	MW
	Revision Date:	2022-04-22	Checked By:	PM

Description	Hydrants <sup>1</sup>				Total Available Fire Flow (L/min)	Total Required Fire Flow <sup>2</sup> (L/min)
	HYD-01	HYD-02	HYD-03	HYD-04		
<b>Tower 5 - 2948 Baseline Road</b>						
Distance from building (m)	105.0	66.0	52.0	85.0	-	-
Direction from building	North	South	West	West	-	-
Maximum fire flow capacity <sup>3</sup> (L/min)	3,785	5,678	5,678	3,785	<b>18,926</b>	5,000

NFPA 1 Table 18.5.4.3	
Distance to Building (m)	Maximum Capacity (L/min)
≤ 76	5,678
> 76 and ≤ 152	3,785
> 152 and ≤ 305	2,839

Notes:

1. Hydrant locations as per GeoOttawa accessed May 25, 2023. Refer to fire hydrant coverage sketch (Figure 2).
2. See FUS (2020) Calculations, Appendix A.2 for fire flow requirements.
3. See NFPA 1 Table 18.5.4.3 for maximum fire flow capacity of hydrants by distance to building.

	Project:	2948 Baseline Road	160401676	
	<b>TABLE 1: FIRE HYDRANT COVERAGE TABLE</b>			
	Revision:	0	Prepared By:	MW
	Revision Date:	2022-04-22	Checked By:	PM

Description	Hydrants <sup>1</sup>				Total Available Fire Flow (L/min)	Total Required Fire Flow <sup>2</sup> (L/min)
	HYD-01	HYD-02	HYD-03	HYD-04		
<b>Tower 6 - 2948 Baseline Road</b>						
Distance from building (m)	16.0	20.0	222.0	155.0	-	-
Direction from building	East	North	South	West	-	-
Maximum fire flow capacity <sup>3</sup> (L/min)	5,678	5,678	2,839	2,839	<b>17,034</b>	3,000

NFPA 1 Table 18.5.4.3	
Distance to Building (m)	Maximum Capacity (L/min)
≤ 76	5,678
> 76 and ≤ 152	3,785
> 152 and ≤ 305	2,839

Notes:

- Hydrant locations as per GeoOttawa accessed April 22, 2022. Refer to fire hydrant coverage sketch (Figure 2).
- See FUS (2020) Calculations, Appendix A.2 for fire flow requirements.
- See NFPA 1 Table 18.5.4.3 for maximum fire flow capacity of hydrants by distance to building.

## Appendix C Sanitary

### C.1 Sanitary Calculation Sheet







## Appendix D Stormwater Servicing

### D.1 Modified Rational Method Sheet



### Stormwater Management Calculations

File No: 160401676  
 Project: 2948 Baseline Road  
 Date: 16-May-23

SWM Approach:  
 Post-development to Pre-development flows

**Post-Development Site Conditions:**

**Overall Runoff Coefficient for Site and Sub-Catchment Areas**

Runoff Coefficient Table									
Catchment Type	Sub-catchment Area	ID / Description		Area (ha) "A"	Runoff Coefficient "C"			"A x C"	Overall Runoff Coefficient
					0.9	0.2			
Controlled - Outlet 200	STM 200		Hard	0.544	0.9		0.489	0.510	0.79
			Soft	0.100	0.2	0.020			
			Subtotal		0.644				
Uncontrolled - Non-Tributary	UNC-3		Hard	0.055	0.9		0.049	0.056	0.64
			Soft	0.032	0.2	0.006			
			Subtotal		0.087				
Uncontrolled - Non-Tributary	UNC-4		Hard	0.027	0.9		0.024	0.024	0.87
			Soft	0.001	0.2	0.000			
			Subtotal		0.028				
Uncontrolled - Non-Tributary	UNC-5		Hard	0.055	0.9		0.050	0.051	0.85
			Soft	0.004	0.2	0.001			
			Subtotal		0.059				
Controlled - Outlet 101	STM 101		Hard	0.240	0.9		0.216	0.238	0.68
			Soft	0.109	0.2	0.022			
			Subtotal		0.349				
Uncontrolled - Non-Tributary	UNC-1		Hard	0.000	0.9		0.000	0.003	0.20
			Soft	0.015	0.2	0.003			
			Subtotal		0.015				
Uncontrolled - Non-Tributary	UNC-2		Hard	0.015	0.9		0.014	0.014	0.90
			Soft	0.000	0.2	0.000			
			Subtotal		0.015				
Uncontrolled - Non-Tributary	UNC-6		Hard	0.006	0.9		0.005	0.007	0.47
			Soft	0.009	0.2	0.002			
			Subtotal		0.015				
<b>Total</b>					<b>1.213</b>		<b>0.901</b>		<b>0.74</b>
<b>Overall Runoff Coefficient= C:</b>									

Total Outlet 200 Areas	0.64 ha
Total Outlet 101 Areas	0.35 ha
Total Tributary Area to Outlet	0.99 ha
Total Outlet 200 Uncontrolled Areas	0.17 ha
Total Outlet 101 Uncontrolled Areas	0.04 ha
Total Uncontrolled Areas (Non-Tributary)	0.22 ha
Total Site	1.21 ha

# Stormwater Management Calculations

## Project #160401676, 2948 Baseline Road Modified Rational Method Calculations for Storage

5 yr Intensity City of Ottawa	$I = a/(t + b)$	a = 998.071	t (min)	I (mm/hr)
		b = 6.053	10	104.19
		c = 0.814	20	70.25
			30	53.93
			40	44.18
			50	37.65
			60	32.94
			70	29.37
			80	26.56
			90	24.29
			100	22.41
			110	20.82
			120	19.47

### 5 YEAR Predevelopment Target Release for Outlet 200 (Phase 5 & 6)

Subdrainage Area: Predevelopment Tributary Area to Outlet  
Area (ha): 0.82  
C: 0.50

Assumed approximate equivalent Time of Concentration

tc (min)	I (5 yr) (mm/hr)	Qtarg (L/s)
12	94.70	107.76

### 5 YEAR Modified Rational Method for Outlet 200 (Phase 5 & 6)

Subdrainage Area: UNC-3 UNC-4 UNC-5 Uncontrolled - Non-Tributary  
Area (ha): 0.09 0.03 0.06 At Outlet 200  
C: 0.64 0.87 0.85

tc (min)	I (5 yr) (mm/hr)	Q3actual (L/s)	Q4actual (L/s)	Q5actual (L/s)	Q6actual (L/s)
10	104.19	16.1	7.1	14.6	37.8
20	70.25	10.8	4.8	9.9	25.5
30	53.93	8.3	3.7	7.6	19.6
40	44.18	6.8	3.0	6.2	16.0
50	37.65	5.8	2.6	5.3	13.7
60	32.94	5.1	2.2	4.6	12.0
70	29.37	4.5	2.0	4.1	10.7
80	26.56	4.1	1.8	3.7	9.6
90	24.29	3.7	1.7	3.4	8.8
100	22.41	3.5	1.5	3.1	8.1
110	20.82	3.2	1.4	2.9	7.6
120	19.47	3.0	1.3	2.7	7.1

Subdrainage Area: STM 200 Controlled - Outlet 200  
Area (ha): 0.64  
C: 0.79  
Discharge (L/s): 29.8 5yr Qtarg less 100yr Uncontrolled Q6actual

tc (min)	I (5 yr) (mm/hr)	Qactual (L/s)	Qrelease (L/s)	Qstored (L/s)	Vstored (m³)
10	104.19	147.6	29.8	117.8	70.7
20	70.25	99.5	29.8	69.7	83.6
30	53.93	76.4	29.8	46.6	83.8
40	44.18	62.6	29.8	32.8	78.6
50	37.65	53.3	29.8	23.5	70.5
60	32.94	46.7	29.8	16.8	60.6
70	29.37	41.6	29.8	11.8	49.5
80	26.56	37.6	29.8	7.8	37.4
90	24.29	34.4	29.8	4.6	24.7
100	22.41	31.7	29.8	1.9	11.5
110	20.82	29.5	29.8	0.0	0.0
120	19.47	27.6	29.8	0.0	0.0

Storage Volume Required (m³) 84

### 5 YEAR Predevelopment Target Release for Outlet 101 (Phase 4)

Subdrainage Area: Predevelopment Tributary Area to Outlet  
Area (ha): 0.39  
C: 0.50

Assumed approximate current Time of Concentration

tc (min)	I (5 yr) (mm/hr)	Qtarg (L/s)
12	94.70	51.86

### 5 YEAR Modified Rational Method for Outlet 101 (Phase 4)

Subdrainage Area: UNC-1 UNC-2 UNC-6 Uncontrolled - Non-Tributary  
Area (ha): 0.02 0.02 0.01 At Outlet 101  
C: 0.20 0.90 0.47

tc (min)	I (5 yr) (mm/hr)	Q1actual (L/s)	Q2actual (L/s)	Q6actual (L/s)	Q6actual (L/s)
10	104.19	0.9	3.9	2.0	6.8
20	70.25	0.6	2.6	1.4	4.6
30	53.93	0.4	2.0	1.1	3.5
40	44.18	0.4	1.7	0.9	2.9
50	37.65	0.3	1.4	0.7	2.5
60	32.94	0.3	1.2	0.6	2.2
70	29.37	0.2	1.1	0.6	1.9
80	26.56	0.2	1.0	0.5	1.7
90	24.29	0.2	0.9	0.5	1.6
100	22.41	0.2	0.8	0.4	1.5
110	20.82	0.2	0.8	0.4	1.4
120	19.47	0.2	0.7	0.4	1.3

Subdrainage Area: STM 101 Controlled - Outlet 101  
Area (ha): 0.35  
C: 0.68  
Discharge (L/s): 38.2 5yr Qtarg less 100yr Uncontrolled Qactual

tc (min)	I (5 yr) (mm/hr)	Qactual (L/s)	Qrelease (L/s)	Qstored (L/s)	Vstored (m³)
10	104.19	68.9	38.2	30.7	18.4
20	70.25	46.4	38.2	8.3	9.9
30	53.93	35.7	35.7	0.0	0.0
40	44.18	29.2	29.2	0.0	0.0
50	37.65	24.9	24.9	0.0	0.0
60	32.94	21.8	21.8	0.0	0.0

## Project #160401676, 2948 Baseline Road Modified Rational Method Calculations for Storage

100 yr Intensity City of Ottawa	$I = a/(t + b)$	a = 1735.688	t (min)	I (mm/hr)
		b = 6.014	10	178.56
		c = 0.820	20	119.95
			30	91.87
			40	75.15
			50	63.95
			60	55.89
			70	49.79
			80	44.99
			90	41.11
			100	37.90
			110	35.20
			120	32.89

### 100 YEAR Predevelopment Target Release for Outlet 200 (Phase 5 & 6)

Subdrainage Area: Predevelopment Tributary Area to Outlet  
Area (ha): 0.82  
C: 0.50

Assumed approximate equivalent Time of Concentration

tc (min)	I (100 yr) (mm/hr)	Q100yr (L/s)
12	162.13	184.51

### 100 YEAR Modified Rational Method for Outlet 200 (Phase 5 & 6)

Subdrainage Area: UNC-3 UNC-4 UNC-5 Uncontrolled - Non-Tributary  
Area (ha): 0.09 0.03 0.06 At Outlet 200  
C: 0.80 1.00 1.00

tc (min)	I (100 yr) (mm/hr)	Q3actual (L/s)	Q4actual (L/s)	Q5actual (L/s)	Q6actual (L/s)
10	178.56	34.5	14.0	29.5	77.9
20	119.95	23.1	9.4	19.8	52.4
30	91.87	17.7	7.2	15.2	40.1
40	75.15	14.5	5.9	12.4	32.8
50	63.95	12.3	5.0	10.6	27.9
60	55.89	10.8	4.4	9.2	24.4
70	49.79	9.6	3.9	8.2	21.7
80	44.99	8.7	3.5	7.4	19.6
90	41.11	7.9	3.2	6.8	17.9
100	37.90	7.3	3.0	6.3	16.5
110	35.20	6.8	2.8	5.8	15.4
120	32.89	6.3	2.6	5.4	14.4

Subdrainage Area: STM 200 Controlled - Outlet 200  
Area (ha): 0.64  
C: 0.99  
Discharge (L/s): 29.8 5yr Qtarg less 100yr Uncontrolled Q6actual

tc (min)	I (100 yr) (mm/hr)	Qactual (L/s)	Qrelease (L/s)	Qstored (L/s)	Vstored (m³)
10	178.56	316.1	29.8	286.3	171.8
20	119.95	212.4	29.8	182.6	126.9
30	91.87	162.7	29.8	132.8	93.1
40	75.15	133.0	29.8	103.2	74.7
50	63.95	113.2	29.8	83.4	63.2
60	55.89	99.0	29.8	69.1	54.9
70	49.79	88.2	29.8	58.3	48.0
80	44.99	79.7	29.8	49.8	41.2
90	41.11	72.8	29.8	43.0	36.0
100	37.90	67.1	29.8	37.3	32.7
110	35.20	62.3	29.8	32.5	29.4
120	32.89	58.2	29.8	28.4	26.6

Storage Volume Required (m³) 251

### 100 YEAR Predevelopment Target Release for Outlet 101 (Phase 4)

Subdrainage Area: Predevelopment Tributary Area to Outlet  
Area (ha): 0.39  
C: 0.50

Assumed approximate current Time of Concentration

tc (min)	I (100 yr) (mm/hr)	Q100yr (L/s)
12	162.13	88.77

### 100 YEAR Modified Rational Method for Outlet 101 (Phase 4)

Subdrainage Area: UNC-1 UNC-2 UNC-6 Uncontrolled - Non-Tributary  
Area (ha): 0.02 0.02 0.01 At Outlet 101  
C: 0.25 1.00 0.59

tc (min)	I (100 yr) (mm/hr)	Q1actual (L/s)	Q2actual (L/s)	Q6actual (L/s)	Q6actual (L/s)
10	178.56	1.9	7.4	4.4	13.7
20	119.95	1.3	5.0	2.9	9.2
30	91.87	1.0	3.8	2.2	7.0
40	75.15	0.8	3.1	1.8	5.8
50	63.95	0.7	2.7	1.6	4.9
60	55.89	0.6	2.3	1.4	4.3
70	49.79	0.5	2.1	1.2	3.8
80	44.99	0.5	1.9	1.1	3.4
90	41.11	0.4	1.7	1.0	3.1
100	37.90	0.4	1.6	0.9	2.9
110	35.20	0.4	1.5	0.9	2.7
120	32.89	0.3	1.4	0.8	2.5

Subdrainage Area: STM 101 Controlled - Outlet 101  
Area (ha): 0.35  
C: 0.85  
Discharge (L/s): 38.2 5yr Qtarg less 100yr Uncontrolled Qactual

tc (min)	I (100 yr) (mm/hr)	Qactual (L/s)	Qrelease (L/s)	Qstored (L/s)	Vstored (m³)
10	178.56	147.6	38.2	109.4	65.6
20	119.95	99.1	38.2	60.9	38.1
30	91.87	75.9	38.2	37.7	23.9
40	75.15	62.1	38.2	23.9	15.2
50	63.95	52.8	38.2	14.7	9.1
60	55.89	46.2	38.2	8.0	4.9

## Stormwater Management Calculations

**Project #160401676, 2948 Baseline Road**  
**Modified Rational Method Calculations for Storage**

70	23.37	19.4	19.4	0.0	0.0
80	26.56	17.6	17.6	0.0	0.0
90	24.29	16.1	16.1	0.0	0.0
100	22.41	14.8	14.8	0.0	0.0
110	20.82	13.8	13.8	0.0	0.0
120	19.47	12.9	12.9	0.0	0.0
<b>Storage Volume Required (m<sup>3</sup>)</b>				<b>19</b>	
<b>SUMMARY TO OUTLET</b>					
<b>Outlet 200 (Phase 5 &amp; 6)</b>					
Allowable Flow to Public Storm Sewer		107.8 L/s			
Uncontrolled Area		0.17 ha			
Total 5yr Flow Uncontrolled		16.1 L/s		Tc = 10 min	
Total 100yr Flow Uncontrolled		77.9 L/s		Tc = 10 min	
Controlled Area		0.64 ha			
Total 5yr Flow to Outlet 200		147.6 L/s		Tc = 10 min	
Total 5yr Flow from Outlet 200		29.8 L/s		Allowable - 100yr Uncontrolled	
Storage Volume Required		84 m <sup>3</sup>			
<b>Outlet 101 (Phase 4)</b>					
Allowable Flow to Public Storm Sewer		51.8 L/s			
Uncontrolled Area		0.04 ha			
Total 5yr Flow Uncontrolled		4.8 L/s		Tc = 10 min	
Total 100yr Flow Uncontrolled		13.7 L/s		Tc = 10 min	
Controlled Area		0.35 ha			
Total 5yr Flow to Outlet 101		68.9 L/s		Tc = 10 min	
Total 5yr Flow from Outlet 101		38.2 L/s		Allowable - 100yr Uncontrolled	
Storage Volume Required		19 m <sup>3</sup>			
<b>Site</b>					
Allowable Flow from Site		159.6 L/s			
5yr Design Flow to Storm Sewer		68.0 L/s			
5yr Uncontrolled Flow		20.9 L/s			
5yr Design Flow		88.9 L/s			

**Project #160401676, 2948 Baseline Road**  
**Modified Rational Method Calculations for Storage**

70	48.79	41.1	38.2	3.0	12.5
80	44.99	37.2	37.2	0.0	0.0
90	41.11	34.0	34.0	0.0	0.0
100	37.90	31.3	31.3	0.0	0.0
110	35.20	29.1	29.1	0.0	0.0
120	32.89	27.2	27.2	0.0	0.0
<b>Storage Volume Required (m<sup>3</sup>)</b>				<b>74</b>	
<b>SUMMARY TO OUTLET</b>					
<b>Outlet 200 (Phase 5 &amp; 6)</b>					
Allowable Flow to Public Storm Sewer		107.8 L/s			
Uncontrolled Area		0.17 ha			
Total 5yr Flow Uncontrolled		N/A L/s		Tc = 10 min	
Total 100yr Flow Uncontrolled		77.9 L/s		Tc = 10 min	
Controlled Area		0.64 ha			
Total 100yr Flow to Outlet 200		316.1 L/s		Tc = 10 min	
Total 100yr Flow from Outlet 200		29.8 L/s		Allowable - 100yr Uncontrolled	
Storage Volume Required		251 m <sup>3</sup>			
<b>Outlet 101 (Phase 4)</b>					
Allowable Flow to Public Storm Sewer		51.8 L/s			
Uncontrolled Area		0.04 ha			
Total 5yr Flow Uncontrolled		N/A L/s		Tc = 10 min	
Total 100yr Flow Uncontrolled		13.7 L/s		Tc = 10 min	
Controlled Area		0.35 ha			
Total 100yr Flow to Outlet 101		147.55 L/s		Tc = 10 min	
Total 100yr Flow from Outlet 101		38.2 L/s		Allowable - 100yr Uncontrolled	
Storage Volume Required		74 m <sup>3</sup>			
<b>Site</b>					
Allowable Flow from Site		159.6 L/s			
100yr Design Flow to Storm Sewer		68.0 L/s			
100yr Uncontrolled Flow		91.6 L/s			
100yr Design Flow		159.6 L/s			

## D.2 Storm Sewer Design Sheet





2948 Baseline Road

**STORM SEWER  
DESIGN SHEET**  
(City of Ottawa)

DESIGN PARAMETERS

$t = a / (t+b)^2$  (As per City of Ottawa Guidelines, 2012)

DATE: 2023-05-25  
REVISION: 1  
DESIGNED BY: PM  
CHECKED BY:

FILE NUMBER: 160401676

a =	998.071	1735.688	MANNING'S n =	0.013	BEDDING CLASS =	B
b =	6.053	6.014	MINIMUM COVER:	2.00	m	
c =	0.814	0.820	TIME OF ENTRY	10	min	

AREA ID NUMBER	LOCATION		AREA (5-YEAR) (ha)	AREA (10-YEAR) (ha)	AREA (ROOF) (ha)	C (-)	ACCUM AREA (BYR) (ha)	A x C (5-YEAR) (ha)	ACCUM AC (BYR) (ha)	ACCUM AREA (100YR) (ha)	A x C (100YR) (ha)	ACCUM (100YR) (ha)	T of C (min)	I <sub>5</sub> -YEAR (mm/h)	I <sub>10</sub> -YEAR (mm/h)	Q <sub>CONTROL</sub> (L/s)	ACCUM. Q <sub>CONTROL</sub> (L/s)	Q <sub>DES</sub> (L/s)	LENGTH (m)	PIPE WIDTH OR DIAMETER (mm)	PIPE HEIGHT (mm)	PIPE SHAPE (-)	MATERIAL (-)	CLASS (-)	SLOPE (%)	Q <sub>DES</sub> (FULL) (L/s)	% FULL (-)	VEL. (FULL) (m/s)	VEL. (ACT) (m/s)
	FROM M.H.	TO M.H.																											
Tower 4 - Cistern 1	STM STUB 101A	STM 101	0.349	0.00	0.00	0.68	0.349	0.237	0.237	0.00	0.000	0.000	10.00	104.19	178.56	38.20	38.2	68.7	2.5	300	300	CIRCULAR	PVC	DR 28	1.00	96.2	39.73%	1.37	1.30
	STM 101	STM 100	0.000	0.00	0.00	0.00	0.000	0.000	0.237	0.00	0.000	0.000	10.03	104.02	178.27	38.20	38.2	68.6	12.7	300	300	CIRCULAR	PVC	DR 28	1.00	96.2	39.73%	1.37	1.30
			<b>10.20</b>																										
Tower 5 & 6 - Cistern 2	STM STUB 200A	STM 200	0.644	0.00	0.00	0.79	0.644	0.509	0.509	0.00	0.000	0.000	10.00	104.19	178.56	29.80	29.8	147.2	1.9	300	300	CIRCULAR	PVC	DR 28	1.00	96.2	30.99%	1.37	1.37
	STM 200	EX-STM MH	0.000	0.00	0.00	0.00	0.000	0.000	0.509	0.00	0.000	0.000	10.02	104.07	178.35	29.80	29.8	147.1	13.8	300	300	CIRCULAR	PVC	DR 28	1.00	96.2	30.99%	1.37	1.37
			<b>10.19</b>																										

## Appendix E Background Studies

### E.1 Geotechnical Investigation (Paterson Group)





# **Geotechnical Investigation**

## **Proposed Multi-Storey Building**

### **Tower 4 to 6**

2946 Baseline Road  
Ottawa, Ontario

Prepared for 11034936 Canada Inc

Report PG6107 – 1 Revision 1 dated May 8, 2023

## Table of Contents

<b>1.0 Introduction .....</b>	<b>1</b>
<b>2.0 Proposed Development .....</b>	<b>1</b>
<b>3.0 Method of Investigation .....</b>	<b>2</b>
3.1 Field Investigation.....	2
3.2 Field Survey.....	3
3.3 Laboratory Testing.....	3
3.4 Analytical Testing .....	3
<b>4.0 Observations .....</b>	<b>4</b>
4.1 Surface Conditions .....	4
4.2 Subsurface Profile .....	4
4.3 Groundwater.....	4
<b>5.0 Discussion .....</b>	<b>5</b>
5.1 Geotechnical Assessment.....	5
5.2 Site Grading and Preparation .....	5
5.3 Foundation Design .....	6
5.4 Design for Earthquakes .....	8
5.5 Basement Slab .....	8
5.6 Basement Wall .....	9
5.7 Pavement Structure.....	10
<b>6.0 Design and Construction Precautions .....</b>	<b>12</b>
6.1 Foundation Drainage and Backfill .....	12
6.2 Protection of Footings Against Frost Action .....	14
6.3 Excavation Side Slopes.....	15
6.4 Pipe Bedding and Backfill.....	16
6.5 Groundwater Control .....	17
6.6 Winter Construction .....	18
6.7 Corrosion Potential and Sulphate.....	19
<b>7.0 Recommendations .....</b>	<b>20</b>
<b>8.0 Statement of Limitations .....</b>	<b>21</b>

---

## Appendices

- Appendix 1**      Soil Profile and Test Data Sheets  
                         Symbols and Terms  
                         Borehole Logs by Others  
                         Analytical Testing Results
- Appendix 2**      Figure 1 – Key Plan  
                         Figure 2 – Water Suppression System  
                         Figure 3 – Elevator Pit Waterproofing  
                         Drawing PG6107-1 – Test Hole Location Plan
- Appendix 3**      Typical Foundation Sleeve Installation

## 1.0 Introduction

Paterson Group (Paterson) was commissioned by 11034936 Canada Inc. to complete a geotechnical investigation for the subject site located at 2946 Baseline Road in the City of Ottawa (refer to Figure 1 - Key Plan presented in Appendix 2). The objective of the investigation was to:

- determine the subsurface soil and groundwater conditions by means of boreholes and monitoring well program.
- provide preliminary geotechnical recommendations for the foundation design of the proposed buildings and provide geotechnical construction precautions which may affect the design.

The following report has been prepared specifically and solely for the aforementioned project which is described herein. The report contains our findings and includes geotechnical recommendations pertaining to the design and construction of the proposed development as understood at the time of this report.

Investigating the presence or potential presence of contamination on the subject property was not part of the scope of work of this present investigation. Therefore, the present report does not address environmental issues.

## 2.0 Proposed Development

Based on the current design information, it is understood that the proposed development will consist of three multi storey residential buildings (Tower 4 to 6). It is understood that the proposed development will consist of 2 to 3 levels of underground parking and storage area. The proposed underground levels are expected to link each residential tower. The current development phase will also include associated at grade asphalt parking areas, access lanes and landscaped areas. It is further anticipated that the site will be fully municipally serviced.

## **3.0 Method of Investigation**

### **3.1 Field Investigation**

#### **Field Program**

The field program for the current investigation was completed from February 8, 9, 10, 11 and 14, 2022. At that time, 10 boreholes were advanced to a maximum depth of 12.8 m below existing grade. The borehole locations were distributed in a manner to provide general coverage of the proposed development taking into consideration existing site features. The borehole locations are shown on Drawing PG6107-1 - Test Hole Location Plan included in Appendix 2.

A previous field investigation was also completed by others on site. Test hole data and locations were considered as part of this geotechnical report.

The boreholes were completed using a track-mounted auger drill rig operated by a two-person crew. All fieldwork was conducted under the full-time supervision of Paterson personnel under the direction of a senior engineer from the geotechnical division. The testing procedure consisted of auguring to the required depths and at the selected locations sampling the overburden.

#### **Sampling and In Situ Testing**

Soil samples were recovered from the auger flights and using a 50 mm diameter split-spoon sampler. The split-spoon samples were placed in sealed plastic bags and transported to our laboratory. The depths at which the auger and split-spoon samples were recovered from the boreholes are shown as AU and SS, respectively, on the Soil Profile and Test Data sheets in Appendix 1.

A Standard Penetration Test (SPT) was conducted in conjunction with the recovery of the split spoon samples. The SPT results are recorded as "N" values on the Soil Profile and Test Data sheets. The "N" value is the number of blows required to drive the split spoon sampler 300 mm into the soil after a 150 mm initial penetration using a 63.5 kg hammer falling from a height of 760 mm. This testing was done in general accordance with ASTM D1586-11 - Standard Test Method for Penetration Test and Split-Barrel Sampling of Soils.

Undrained shear strength testing was carried out in cohesive soils using a field vane apparatus.

The overburden thickness was evaluated by a dynamic cone penetration test (DCPT). The DCPT consists of driving a steel drill rod, equipped with a 50 mm diameter cone at the tip, using a 63.5 kg hammer falling from a height of 760 mm. The number of blows required to drive the cone into the soil is recorded for each 300 mm increment.

Subsurface conditions observed in the test holes were recorded in detail in the field. Reference should be made to the Soil Profile and Test Data sheets presented in Appendix 1 for specific details of the soil profile encountered at the test hole locations.

### **Groundwater**

PVC groundwater monitoring wells were installed within boreholes BH 1-22, BH 6-22, and BH 10-22 and flexible piezometers were installed in boreholes all other boreholes to permit monitoring of the groundwater level subsequent to the completion of the sampling program.

The groundwater observations are discussed in Subsection 4.3 and presented in the Soil Profile and Test Data sheets in Appendix 1.

### **3.2 Field Survey**

The ground surface elevations at the test hole locations are referenced to a geodetic datum and measured on field by Paterson's personnel. The locations of the boreholes and the ground surface elevations for each borehole location are presented on Drawing PG6107-1 -Test Hole Location Plan in Appendix 2.

### **3.3 Laboratory Testing**

The soil samples were recovered from the subject site and visually examined in Paterson's laboratory to review the field logs. All samples will be stored in the laboratory for a period of one month after issuance of this report. The samples will then be discarded unless otherwise directed.

### **3.4 Analytical Testing**

One (1) soil sample was submitted for analytical testing to assess the corrosion potential for exposed ferrous metals and the potential of sulphate attacks against subsurface concrete structures. The sample was submitted to determine the concentration of sulphate and chloride, the resistivity and the pH of the sample. If available, the results are presented in Appendix 1 and are discussed further in Subsection 6.7.

## 4.0 Observations

### 4.1 Surface Conditions

The subject site is currently mostly paved areas and occupied by a commercial building. The site is relatively flat with a light slope down towards Baseline Road. The property is surrounded west by Sandcastle Drive, to the south by a residential development, to the north by Baseline Road and to the east by ongoing construction of Towers 1 to 3 of the subject development project.

### 4.2 Subsurface Profile

#### Overburden

Generally, the soil profile encountered at the test hole locations consists of a flexible asphalt pavement and granular crushed stones with silty clay or silty sand fill layer overlying a firm to very stiff brown silty clay crust followed by a deep, stiff to very stiff grey silty clay deposit. A layer of glacial till, consisting of sand and gravel within a silty clay soil matrix was encountered at boreholes BH 5-22 and BH 10-22.

A layer of grey silty sand with clay was encountered approximately 12.2 to 12.6 m below existing grade in BH 1-22. The silt and sand content of the silty clay material was also noted to increase with depth.

DCPT was completed at BH 2-22, BH 4-22, BH 6-22 and BH 9-22, practical refusal was encountered at a depth of 12.6, 12.6, 12.8 and 14.0 m respectively. Reference should be made to the Soil Profile and Test Data sheets in Appendix 1 for the details of the soil profile encountered at each test hole location.

#### Bedrock

Based on available geological mapping, the bedrock in the area is part of the Oxford formation, which consists of dolomite. Also, based on available geological mapping, the overburden thickness is expected to range from 10 to 15 m.

### 4.3 Groundwater

Groundwater level readings were recorded on February 24, 2022, at the piezometer and monitoring well locations. The groundwater level readings are presented in the Soil Profile and Test Data sheets in Appendix 1. Long-term groundwater level can also be estimated based on the observed color, moisture levels and consistency of the recovered soil samples. Based on these observations, the long-term groundwater level is expected between 4 to 5 m depth. It should be noted that groundwater levels are subject to seasonal fluctuations, therefore the groundwater levels could vary at the time of construction.

## **5.0 Discussion**

### **5.1 Geotechnical Assessment**

#### **Foundation Design Considerations**

From a geotechnical perspective, the subject site is considered suitable for the proposed development. It is expected that the anticipated building loads are too high to found the proposed building over a conventional shallow spread footing foundations. It is expected that the main tower super structures will be founded on piles while the surrounding levels of underground parking will be founded on conventional spread footings placed on an undisturbed stiff silty clay bearing surface.

Due to the presence of the silty clay layer, the subject site will be subjected to a permissible grade restriction. The permissible grade raise recommendations are further discussed in Subsection 5.3.

The above and other considerations are further discussed in the following sections.

### **5.2 Site Grading and Preparation**

#### **Stripping Depth**

Topsoil and deleterious fill, such as those containing organics, should be stripped from under any buildings, paved areas, pipe bedding and other settlement sensitive structures.

#### **Fill Placement**

Fill placed for grading beneath the building area should consist, unless otherwise specified, of clean imported granular fill, such as Ontario Provincial Standard Specifications (OPSS) Granular A or Granular B Type II. The fill material should be tested and approved prior to delivery to the site. The fill should be placed in maximum 300 mm thick lifts and compacted to 98% of the material's standard Proctor maximum dry density (SPMDD).

Site-excavated soil, whether native or existing fill, can be placed as general landscaping fill where settlement is a minor concern of the ground surface. These materials should be spread in thin lifts and at least compacted by the tracks of the spreading equipment to minimize voids. If these materials are to be placed to increase the subgrade level for areas to be paved, the fill should be compacted in maximum 300 mm thick lifts and to a minimum density of 95% of the respective SPMDD.



Non-specified existing fill and site-excavated soils are not suitable for placement as backfill against foundation walls due to the frost heave potential of the site excavated soils below settlement sensitive areas, such as concrete sidewalks and exterior concrete entrance areas.

## **5.3 Foundation Design**

### **Conventional shallow Footings**

Strip footings, up to 3 m wide, and pad footings, up to 6 m wide, placed over an undisturbed, stiff grey silty clay bearing surface expected at the underground parking elevation can be designed using bearing resistance value at serviceability limit states (SLS) of **150 kPa** and a factored bearing resistance value at ultimate limit states (ULS) of **225 kPa**.

A geotechnical resistance factor of 0.5 was applied to the reported bearing resistance values at ULS.

Footings placed over engineered fill, approved by the geotechnical consultant, can be designed using the above noted bearing resistance values.

An undisturbed soil bearing surface consists of one from which all topsoil and deleterious materials, such as loose, frozen or disturbed soil, have been removed prior to the placement of concrete for footings.

The bearing resistance value given for footings at SLS will be subjected to potential post construction total and differential settlements of 25 and 20 mm, respectively.

### **Lateral Support**

The bearing medium under footing-supported structures is required to be provided with adequate lateral support with respect to excavations and different foundation levels. Above the groundwater level, adequate lateral support is provided to a stiff silty clay when a plane extending down and out from the bottom edge of the footing at a minimum of 1H:1V passes only through in situ soil or engineered fill.

### **Raft Foundation**

Consideration could be given to raft foundation, if the buildings loads exceed the bearing resistance values provided for a conventional shallow footings. The following parameters may be used for raft design over a firm to stiff silty clay bearing surface.

For design purposes, it was assumed that the base of the raft foundation will be located at a minimum depth of 6 m below ground surface.

The amount of settlement of the raft slab will be dependent on the sustained raft contact pressure. The bearing resistance value at SLS (contact pressure) of **200 kPa** will be considered acceptable. The loading conditions for the contact pressure are based on sustained loads, that are generally taken to be 100% Dead Load and 50% Live Load. The factored bearing resistance (contact pressure) at ULS can be taken as **300 kPa**. A geotechnical resistance factor of 0.5 was applied to the bearing resistance value at ULS.

The modulus of subgrade reaction was calculated to be **4 MPa/m** for a contact pressure of **200 kPa**. The raft foundation design is required to consider the relative stiffness of the reinforced concrete slab and the supporting bearing medium.

The proposed building constructed over the silty clay deposit within the subject site can be designed using the above parameters with a total and differential settlement of 25 and 15 mm, respectively.

### Piled Foundation

It is expected that the proposed buildings could be constructed over concrete filled steel pipe piles driven to refusal on the bedrock surface.

For deep foundations, concrete-filled steel pipe piles are generally utilized in the Ottawa area. Applicable pile resistance at SLS values and factored pile resistance at ULS values are given in Table 1. A resistance factor of 0.4 has been incorporated into the factored ULS values. Note that these are all geotechnical axial resistance values.

The geotechnical pile resistance values were estimated using the Hiley dynamic formula, to be confirmed during pile installation with a program of dynamic monitoring. For this project, the dynamic monitoring of 2 to 4 piles is recommended. This is considered to be the minimum monitoring program, as the piles under shear walls may be required to be driven using the maximum recommended driving energy to achieve the greatest factored resistance at ULS values. Re-striking of all piles at least once will also be required after at least 48 hours have elapsed since initial driving.

Table 1 - Pile Foundation Design Data					
Pile Outside Diameter (mm)	Pile Wall Thickness (mm)	Geotechnical Axial Resistance		Final Set (blows/ 12 mm)	Transferred Hammer Energy (kJ)
		SLS (kN)	Factored at ULS (kN)		
245	9	925	1110	6	27
245	11	1050	1260	6	31
245	13	1200	1440	6	35

## **Permissible Grade Raise Recommendations**

The grade raise restriction for the subject site was calculated to be **2.0 m** above original ground surface.

To reduce potential long term liabilities, consideration should be given to accounting for larger groundwater lowering and providing means to reduce long term groundwater lowering (e.g. clay dykes, restriction on planting around the settlement sensitive structures, etc.). It should be noted that building over silty clay deposits increases the likelihood of building movements and therefore of cracking. The use of steel reinforcement in foundations placed at key structural locations will tend to reduce foundation cracking as compared to unreinforced foundations.

## **5.4 Design for Earthquakes**

The proposed site can be taken as seismic site response Class C as defined in the Ontario Building Code 2012 (OBC 2012; Table 4.1.8.4.A) for foundations considered at this site. The soils underlying the site are not susceptible to liquefaction.

## **5.5 Basement Slab**

With the removal of all topsoil and deleterious fill material, the native soil will be considered to be an acceptable subgrade surface on which to commence backfilling for the basement slab. Any soft areas should be removed and backfilled with appropriate backfill material. OPSS Granular A or Granular B Type II, with a maximum particle size of 50 mm, are recommended for backfilling below the floor slab. It is recommended that the upper 200 mm of sub-floor fill consist of OPSS Granular A crushed stone. All backfill materials within the footprint of the proposed building should be placed in maximum 300 mm thick loose layers and compacted to at least 98% of the SPMDD.

A concrete mud slab should be placed to protect the native soil from worker traffic and equipment before pouring the raft slab.

Any soft areas should be removed and backfilled with appropriate backfill material. OPSS Granular B Type II, with a maximum particle size of 50 mm, are recommended for backfilling below the floor slab.

## 5.6 Basement Wall

There are several combinations of backfill materials and retained soils that could be applicable for the basement walls of the subject structure. However, the conditions can be well-represented by assuming the retained soil consists of a material with an angle of internal friction of 30 degrees and a bulk (drained) unit weight of 20 kN/m<sup>3</sup>. The applicable effective (undrained) unit weight of the retained soil can be taken as 13 kN/m<sup>3</sup>, where applicable. A hydrostatic pressure should be added to the total static earth pressure when using the effective unit weight.

### Lateral Earth Pressures

The static horizontal earth pressure ( $p_o$ ) can be calculated using a triangular earth pressure distribution equal to  $K_o \cdot \gamma \cdot H$  where:

- $K_o$  = at-rest earth pressure coefficient of the applicable retained soil, 0.5
- $\gamma$  = unit weight of fill of the applicable retained soil (kN/m<sup>3</sup>)
- $H$  = height of the wall (m)

An additional pressure having a magnitude equal to  $K_o \cdot q$  and acting on the entire height of the wall should be added to the above diagram for any surcharge loading,  $q$  (kPa), that may be placed at ground surface adjacent to the wall. The surcharge pressure will only be applicable for static analyses and should not be used in conjunction with the seismic loading case.

Actual earth pressures could be higher than the “at-rest” case if care is not exercised during the compaction of the backfill materials to maintain a minimum separation of 0.3 m from the walls with the compaction equipment.

### Seismic Earth Pressures

The total seismic force ( $P_{AE}$ ) includes both the earth force component ( $P_o$ ) and the seismic component ( $\Delta P_{AE}$ ). The seismic earth force ( $\Delta P_{AE}$ ) can be calculated using  $0.375 \cdot a_c \cdot \gamma \cdot H^2/g$  where:

- $a_c = (1.45 - a_{max}/g)a_{max}$
- $\gamma$  = unit weight of fill of the applicable retained soil (kN/m<sup>3</sup>)
- $H$  = height of the wall (m)
- $g$  = gravity, 9.81 m/s<sup>2</sup>

The peak ground acceleration, ( $a_{max}$ ), for the Ottawa area is 0.32g according to OBC 2012. Note that the vertical seismic coefficient is assumed to be zero.

The earth force component ( $P_o$ ) under seismic conditions can be calculated using  $P_o = 0.5 K_o \gamma H^2$ , where  $K_o = 0.5$  for the soil conditions noted above.

The total earth force ( $P_{AE}$ ) is considered to act at a height,  $h$  (m), from the base of the wall, where:

$$h = \{P_o \cdot (H/3) + \Delta P_{AE} \cdot (0.6 \cdot H)\} / P_{AE}$$

The earth forces calculated are unfactored. For the ULS case, the earth loads should be factored as live loads, as per OBC 2012.

## 5.7 Pavement Structure

Car only parking areas, access lanes and heavy truck parking areas are anticipated at this site. The proposed pavement structures are shown in Tables 2 and 3.

<b>Table 2 - Recommended Pavement Structure - Car Only Parking Areas</b>	
<b>Thickness (mm)</b>	<b>Material Description</b>
50	<b>Wear Course</b> - HL-3 or Superpave 12.5 Asphaltic Concrete
150	<b>BASE</b> - OPSS Granular A Crushed Stone
300	<b>SUBBASE</b> - OPSS Granular B Type II
<b>SUBGRADE</b> - Either fill, in situ soil, or OPSS Granular B Type I or II material placed over in situ soil or fill	

<b>Table 3 - Recommended Pavement Structure Access Lanes and Heavy Truck Parking Areas</b>	
<b>Thickness (mm)</b>	<b>Material Description</b>
40	<b>Wear Course</b> - Superpave 12.5 Asphaltic Concrete
50	<b>Binder Course</b> - Superpave 19.0 Asphaltic Concrete
150	<b>BASE</b> - OPSS Granular A Crushed Stone
450	<b>SUBBASE</b> - OPSS Granular B Type II
<b>SUBGRADE</b> - Either fill, in situ soil, or OPSS Granular B Type I or II material placed over in situ soil or fill	

Minimum Performance Graded (PG) 58-34 asphalt cement should be used for this project.

If soft spots develop in the subgrade during compaction or due to construction traffic, the affected areas should be excavated and replaced with OPSS Granular B Type II material. The pavement granular base and subbase should be placed in maximum 300 mm thick lifts and compacted to a minimum of 98% of the material's SPMDD using suitable vibratory equipment.

The pavement granular base and subbase should be placed in maximum 300 mm thick lifts and compacted to a minimum of 98% of the material's SPMDD using suitable compaction equipment.

### **Pavement Structure Drainage**

Satisfactory performance of the pavement structure is largely dependent on keeping the contact zone between the subgrade material and the base stone in a dry condition. Failure to provide adequate drainage under conditions of heavy wheel loading can result in the fine subgrade soil being pumped into the voids in the stone subbase, thereby reducing its load carrying capacity.

Where silty clay is encountered at subgrade level, consideration should be given to installing subdrains during the pavement construction. These drains should be constructed according to City of Ottawa specifications. The drains should be connected to a positive outlet. The subgrade surface should be crowned to promote water flow to the drainage lines. The subdrains will help drain the pavement structure, especially in early Spring when the subgrade is saturated and weaker and, therefore, more susceptible to permanent deformation.

### **Pavement Structure Drainage**

Satisfactory performance of the pavement structure is largely dependent on keeping the contact zone between the subgrade material and the base stone in a dry condition. Failure to provide adequate drainage under conditions of heavy wheel loading can result in the fine subgrade soil being pumped into the voids in the stone subbase, thereby reducing its load carrying capacity.

Where silty clay is encountered at subgrade level, consideration should be given to installing subdrains during the pavement construction. These drains should be constructed according to City of Ottawa specifications. The drains should be connected to a positive outlet. The subgrade surface should be crowned to promote water flow to the drainage lines. The subdrains will help drain the pavement structure, especially in early Spring when the subgrade is saturated and weaker and, therefore, more susceptible to permanent deformation.

## 6.0 Design and Construction Precautions

### 6.1 Foundation Drainage and Backfill

It is recommended that a drainage geocomposite, such as Miradrain G100N or Delta Drain 6000 installed on the exterior foundation walls and extend down to the footing level. It is further recommended that 100 to 150 mm diameter drainage sleeves at 5 m spacing be cast in the footing or at the foundation wall/footing interface to allow the infiltration of water to flow to the interior underfloor drainage system.

In areas where a perimeter drainage pipe consisting of a 150 mm perforated corrugated plastic pipe, surrounded on all sides by a minimum of 150 mm of 19 mm clear crushed stone is placed at the footing level. The requirement for the drainage sleeves noted above can be reduced to 15 m spacing.

The exterior perimeter and underfloor drainage system should direct water to the sump pit(s) within the lower basement area.

A damp proofing layer such as Bakor 710-11 or equivalent should be applied to the foundation prior to the installation of the composite drainage layer.

#### **Underfloor Drainage**

Underfloor drainage will be required to control water infiltration. For preliminary design purposes, we recommend that 100 to 150 mm diameter perforated pipes be placed at 5 m centres. The spacing of the underfloor drainage system should be confirmed at the time of completing the excavation when water infiltration can be better assessed.

#### **Water Suppression System**

A water suppression system will be required for the basement level below a geodetic elevation of 73.20 m to avoid dewatering the surrounding areas adjacent to buildings with shallower founding depths which can cause differential settlement. To manage and control groundwater water infiltration over the long term, the following water suppression system is recommended to be installed for the exterior foundation walls and underfloor drainage (refer to Figure 2 – Water Suppression System in Appendix 2 for an illustration of this system cross-section):

- A concrete mud slab will be required to create a horizontal hydraulic barrier to lessen the water infiltration at the base of the excavation and will consist of a 300 mm thick layer of 25 MPa compressive strength concrete. The 300 mm minimum thickness is required to enable the support of construction traffic until the footings, pile caps and grade beams are poured and the area is backfilled for the lower floor slab to resist minor buoyancy forces and hydrostatic pressure.

- ❑ A waterproofing membrane will be required to lessen the effect of water infiltration for the underground parking P-3 Levels starting at underside of P-2 Level which is approximately 6-7 m below finished grade. The waterproofing membrane will consist of bentonite panels or approved equivalent fastened to the soldier pile and timber lagging shoring system. The membrane should extend to the bottom of the excavation at the founding level of the proposed footings over the concrete mud slab.
- ❑ A composite drainage layer will be placed from finished grade to the bottom of the foundation wall. It's recommended that the composite drainage system (such as Delta Drain 6000 or equivalent) extend down to the bottom of the foundation wall. It's expected that 150 mm diameter sleeves placed at 3 m centres be cast in the foundation wall at the footing interface to allow the infiltration of water to flow to an interior perimeter drainage pipe. The perimeter drainage pipe should direct water to the sump pit(s) within the lower basement area. Water infiltration will result from two sources. The first will be water infiltration from the upper 6-7 m which is above the vertical waterproofed area. The second source will be groundwater breaching the waterproofing membrane.

Membranes and drainage board should be installed as per manufacturer's specification. Paterson should review any proposal by supplier prior to the field work.

### **Elevator Pit Waterproofing**

The elevator shaft exterior foundation walls should be waterproofed to avoid any infiltration into the elevator pit. It is recommended that a waterproofing membrane, such as Colphene Torch'n Stick (or approved other) be applied to the exterior of the elevator shaft foundation wall.

The Colphene Torch'n Stick waterproofing membrane should extend over the vertical portion of the raft slab and down to the top of the footing in accordance with the manufacturer's specifications. A continuous PVC waterstop such as Southern waterstop 14RCB or equivalent should be installed within the interface between the concrete base slab below the elevator shaft foundation walls.

The 150 mm diameter perforated corrugated pipe underfloor drainage should be placed along the perimeter of the exterior sidewalls and provided a gravity connection to the sump pump basin or the elevator sump pit.

The foundation wall of the elevator shaft and buildings sump pit should host a PVC sleeve to allow any water trapped within the interior side of the structures to be discharged to the associated sump pump. A minimum 100 mm diameter perforated, corrugated drainage pipe should extend from the sleeve towards the associated drainage system by gravity drainage and mechanical connection to the associated system. Also, the contractor should ensure that the opening is properly sealed to prevent water from entering the subject structure.



A protection board should be placed over the waterproofing membrane to protect the waterproofing membrane from damage during backfilling operations. The area between the pit structure and bedrock/soil excavation face can be in-filled with lean concrete, OPSS Granular A or Granular B Type II crushed stone.

It should be noted that a waterproofed concrete (with Xypex Additive, or equivalent) is optional for this waterproofing option. Refer to the attached Figure 3- Elevator Waterproofing Detail, for specific details of the waterproofing recommendation.

### **Foundation Backfill**

Backfill against the exterior sides of the foundation walls should consist of free-draining non frost susceptible granular materials. The greater part of the site excavated materials will be frost susceptible and, as such, are not recommended for re-use as backfill against the foundation walls, unless used in conjunction with a drainage geocomposite, such as Miradrain G100N or Delta Drain 6000, connected to the perimeter foundation drainage system. Imported granular materials, such as clean sand or OPSS Granular B Type I granular material, should otherwise be used for this purpose.

### **Adverse Effects of Dewatering on Adjacent Properties**

Based on the expected foundation level of Towers 4 to 6 and the depth of the groundwater level, the proposed building could be founded just below the long term groundwater table and match Towers 1 to 3. Any minor dewatering will be temporary during the construction period and will be considered relatively negligible for the neighbouring buildings. Therefore, adverse effects to the surrounding buildings or properties are not expected due to the proposed development. A water suppression system will be used for the foundation walls extending lower than 73.2 m.

## **6.2 Protection of Footings Against Frost Action**

Perimeter footings, of heated structures are required to be insulated against the deleterious effect of frost action. A minimum of 1.5 m thick soil cover (or equivalent) should be provided in this regard.

A minimum of 2.1 m thick soil cover (or equivalent) should be provided for other exterior unheated footings.

The underground parking area should not require protection against frost action due to the founding depth. Unheated structures, such as the access ramp wall footings, may be required to be insulated against the deleterious effect of frost action. A minimum of 2.1 m of soil cover alone, or a minimum of 0.6 m of soil cover, in conjunction with foundation insulation, should be provided.

## 6.3 Excavation Side Slopes

### Temporary Side Slopes

The temporary excavation side slopes anticipated should either be excavated to acceptable slopes or retained by shoring systems from the beginning of the excavation until the structure is backfilled.

The excavation side slopes above the groundwater level extending to a maximum depth of 3 m should be cut back at 1H:1V or flatter. A field review should be completed by Paterson at the time of construction to assess the side slope of excavation deeper than 3 m. The subsurface soil is considered to be mainly a Type 2 and 3 soil according to the Occupational Health and Safety Act and Regulations for Construction Projects.

Excavated soil should not be stockpiled directly at the top of excavations and heavy equipment should maintain safe working distance from the excavation sides.

Slopes in excess of 3 m in height should be periodically inspected by the geotechnical consultant in order to detect if the slopes are exhibiting signs of distress.

A trench box is recommended to protect personnel working in trenches with steep or vertical sides. Services are expected to be installed by “cut and cover” methods and excavations should not remain open for extended periods of time.

### Temporary Shoring

Temporary shoring may be required for the overburden soil to complete the required excavations where insufficient room is available for open cut methods. The shoring requirements designed by a structural engineer specializing in those works will depend on the depth of the excavation, the proximity of the adjacent structures and the elevation of the adjacent building foundations and underground services. The design and implementation of these temporary systems will be the responsibility of the excavation contractor and their design team. Inspections and approval of the temporary system will also be the responsibility of the designer. Geotechnical information provided below is to assist the designer in completing a suitable and safe shoring system. The designer should take into account the impact of a significant precipitation event and designate design measures to ensure that a precipitation will not negatively impact the shoring system or soils supported by the system. Any changes to the approved shoring design system should be reported immediately to the owner’s structural designer prior to implementation.

The temporary system could consist of soldier pile and lagging system or interlocking steel sheet piling. Any additional loading due to street traffic, construction equipment, adjacent structures and facilities, etc., should be included to the earth pressures described below. These systems could be cantilevered, anchored or braced. Generally, it is expected that the shoring systems will be provided with tie-back rock anchors to ensure their stability. The shoring system is recommended to be adequately supported to resist toe failure and inspected to ensure that the sheet piles extend well below the excavation base. It should be noted if consideration is being given to utilizing a raker style support for the shoring system that lateral movements can occur and the structural engineer should ensure that the design selected minimizes these movements to tolerable levels.

The earth pressures acting on the shoring system may be calculated with the following parameters.

<b>Table 4 - Soil Parameters</b>	
<b>Parameters</b>	<b>Values</b>
Active Earth Pressure Coefficient ( $K_a$ )	0.33
Passive Earth Pressure Coefficient ( $K_p$ )	3
At-Rest Earth Pressure Coefficient ( $K_o$ )	0.5
Dry Unit Weight ( $\gamma$ ), kN/m <sup>3</sup>	20
Effective Unit Weight ( $\gamma$ ), kN/m <sup>3</sup>	13

The active earth pressure should be calculated where wall movements are permissible while the at-rest pressure should be calculated if no movement is permissible. The dry unit weight should be calculated above the groundwater level while the effective unit weight should be calculated below the groundwater level.

The hydrostatic groundwater pressure should be included to the earth pressure distribution wherever the effective unit weight are calculated for earth pressures. If the groundwater level is lowered, the dry unit weight for the soil/bedrock should be calculated full weight, with no hydrostatic groundwater pressure component.

For design purposes, the minimum factor of safety of 1.5 should be calculated.

## 6.4 Pipe Bedding and Backfill

Bedding and backfill materials should be in accordance with the most recent Material Specifications & Standard Detail Drawings from the Department of Public Works and Services, Infrastructure Services Branch of the City of Ottawa.

A minimum of 150 mm of OPSS Granular A should be placed for bedding for sewer or water pipes when placed on soil subgrade. The bedding should extend to the spring line of the pipe. Cover material, from the spring line to a minimum of 300 mm above the obvert of the pipe should consist of OPSS Granular A (concrete or PSM PVC pipes) or sand (concrete pipe). The bedding and cover materials should be placed in maximum 225 mm thick lifts and compacted to 95% of the material's SPMDD.

Where hard surface areas are considered above the trench backfill, the trench backfill material within the frost zone (about 1.8 m below finished grade) should match the soils exposed at the trench walls to reduce the potential differential frost heaving. The trench backfill should be placed in maximum 300 mm thick loose lifts and compacted to a minimum of 95% of the SPMDD.

To reduce long term lowering of the groundwater level at this site, clay seals should be provided in the service trenches. The seals should be at least 1.5 m long and should extend from trench wall to trench wall. Generally, the seals should extend from the frost line and fully penetrate the bedding, subbedding and cover material. The barriers should consist of relatively dry and compatible brown silty clay placed in maximum 225 mm thick loose layers and compacted to a minimum of 95% of the material's SPMDD. The clay seals should be placed at the site boundaries and at stratigic locations at no more than 60 m intervals in the service trenches.

## **6.5 Groundwater Control**

### **Groundwater Control for Building Construction**

Due to the relatively impervious nature of the silty clay materials, it is anticipated that groundwater infiltration into the excavations should be low and controllable using open sumps. It is also expected that sandy layers encountered towards the south of the site will allow for more water infiltration in the excavation. The contractor should be prepared to control the water and discharge it away from any bearing surface. Pumping from open sumps should be sufficient to control the groundwater influx through the sides of shallow excavations.

It is expected that the site will be dewatered using one or multiple dry wells placed at the bottom of the excavation. Pumps should be running within the wells until the foundations is completely backfilled.

### **Permit to Take Water**

A temporary Ministry of the Environment, Conservation and Parks (MECP) permit to take water (PTTW) may be required for this project if more than 400,000 L/day of ground and/or surface water is to be pumped during the construction phase. A minimum of 4 to 5 months should be allowed for completion of the PTTW application package and issuance of the permit by the MECP.

For typical ground or surface water volumes being pumped during the construction phase, between 50,000 to 400,000 L/day, it is required to register on the Environmental Activity and Sector Registry (EASR). A minimum of two to four weeks should be allotted for completion of the EASR registration and the Water Taking and Discharge Plan to be prepared by a Qualified Person as stipulated under O.Reg. 63/16. If a project qualifies for a PTTW based upon anticipated conditions, an EASR will not be allowed as a temporary dewatering measure while awaiting the MECP review of the PTTW application.

The contractor should be prepared to direct water away from all bearing surfaces and subgrades, regardless of the source, to prevent disturbance to the founding medium.

### **Long-term Groundwater Control**

The recommendations for the proposed building long-term groundwater control are presented in Subsection 6.1. Any groundwater encountered along the building perimeter or sub-slab drainage system will be directed to the proposed building cistern/sump pit. Provided the proposed groundwater infiltration control system is properly implemented and approved by the geotechnical consultant at the time of construction, the groundwater flow should be low (i.e.- less than 25,000 L/day) with peak periods noted after rain events. A more accurate estimate can be provided at the time of construction, once groundwater infiltration levels are observed. The groundwater flow should be controllable using conventional open sumps.

## **6.6 Winter Construction**

Precautions must be taken if winter construction is considered for this project.

The subsurface conditions mostly consist of frost susceptible materials. In presence of water and freezing conditions ice could form within the soil mass. Heaving and settlement upon thawing could occur.

In the event of construction during below zero temperatures, the founding stratum should be protected from freezing temperatures by the installation of straw, propane heaters and tarpaulins or other suitable means. The base of the excavations should be insulated from sub-zero temperatures immediately upon exposure and until such time as heat is adequately supplied to the building and the footings are protected with sufficient soil cover to prevent freezing at founding level.

The trench excavations and pavement construction are also difficult activities to complete during freezing conditions without introducing frost in the subgrade or in the excavation walls and bottoms. Precautions should be taken if such activities are to be carried out during freezing conditions.

## 6.7 Corrosion Potential and Sulphate

The results of the analytical testing of one (1) soil sample show that the sulphate content is less than 0.1%. This result is indicative that Type 10 Portland cement (normal cement) would be appropriate. The results of the chloride content and pH indicate that they are not significant factors in creating a corrosive environment for exposed ferrous metals at this site while the resistivity tests yielded results indicative of a non aggressive to slightly aggressive corrosive environment.

## 7.0 Recommendations

For the foundation design data provided herein to be applicable that a materials testing and observation services program is required to be completed. The following aspects be performed by the geotechnical consultant:

- Observation of all bearing surfaces prior to the placement of concrete.
- Sampling and testing of the concrete and fill materials.
- Observation of piling activities, if applicable.
- Observation of foundation drainage and waterproofing installation, if applicable.
- Observation of the placement of the foundation insulation, if applicable.
- Periodic observation of the condition of unsupported excavation side slopes in excess of 3 m in height, if applicable.
- Observation of all subgrades prior to backfilling and follow-up field density tests to determine the level of compaction achieved.
- Field density tests to determine the level of compaction achieved.
- Sampling and testing of the bituminous concrete including mix design reviews.

A report confirming the construction has been conducted in general accordance with the recommendations could be issued, upon request, following the completion of a satisfactory materials testing and observation program by the geotechnical consultant.

## 8.0 Statement of Limitations

The recommendations made in this report are in accordance with our present understanding of the project. We request that we be permitted to review the grading plan once available and our recommendations when the drawings and specifications are complete.

A geotechnical investigation of this nature is a limited sampling of a site. The recommendations are based on information gathered at the specific test locations and can only be extrapolated to an undefined limited area around the test locations. The extent of the limited area depends on the soil, bedrock and groundwater conditions, as well the history of the site reflecting natural, construction, and other activities. Should any conditions at the site be encountered which differ from those at the test locations, we request notification immediately in order to permit reassessment of our recommendations.

The present report applies only to the project described in this document. Use of this report for purposes other than those described herein or by person(s) other than 11034936 Canada Inc or their agent(s) is not authorized without review by Paterson Group for the applicability of our recommendations to the altered use of the report.

**Paterson Group Inc.**

  
Nicolas Seguin, EIT



  
Joey R. Villeneuve, M.A.Sc., P.Eng, ing.

**Report Distribution:**

- 6382983 Canada Inc. (Brigil Construction)
- Paterson Group Inc



# APPENDIX 1

SOIL PROFILE AND TEST DATA SHEETS

SYMBOLS AND TERMS

BOREHOLE LOGS BY OTHERS

ANALYTICAL TESTING RESULTS

DATUM Geodetic

REMARKS

BORINGS BY CME-55 Low Clearance Drill

DATE 2022 February 8

FILE NO. **PG6107**

HOLE NO. **BH 1-22**

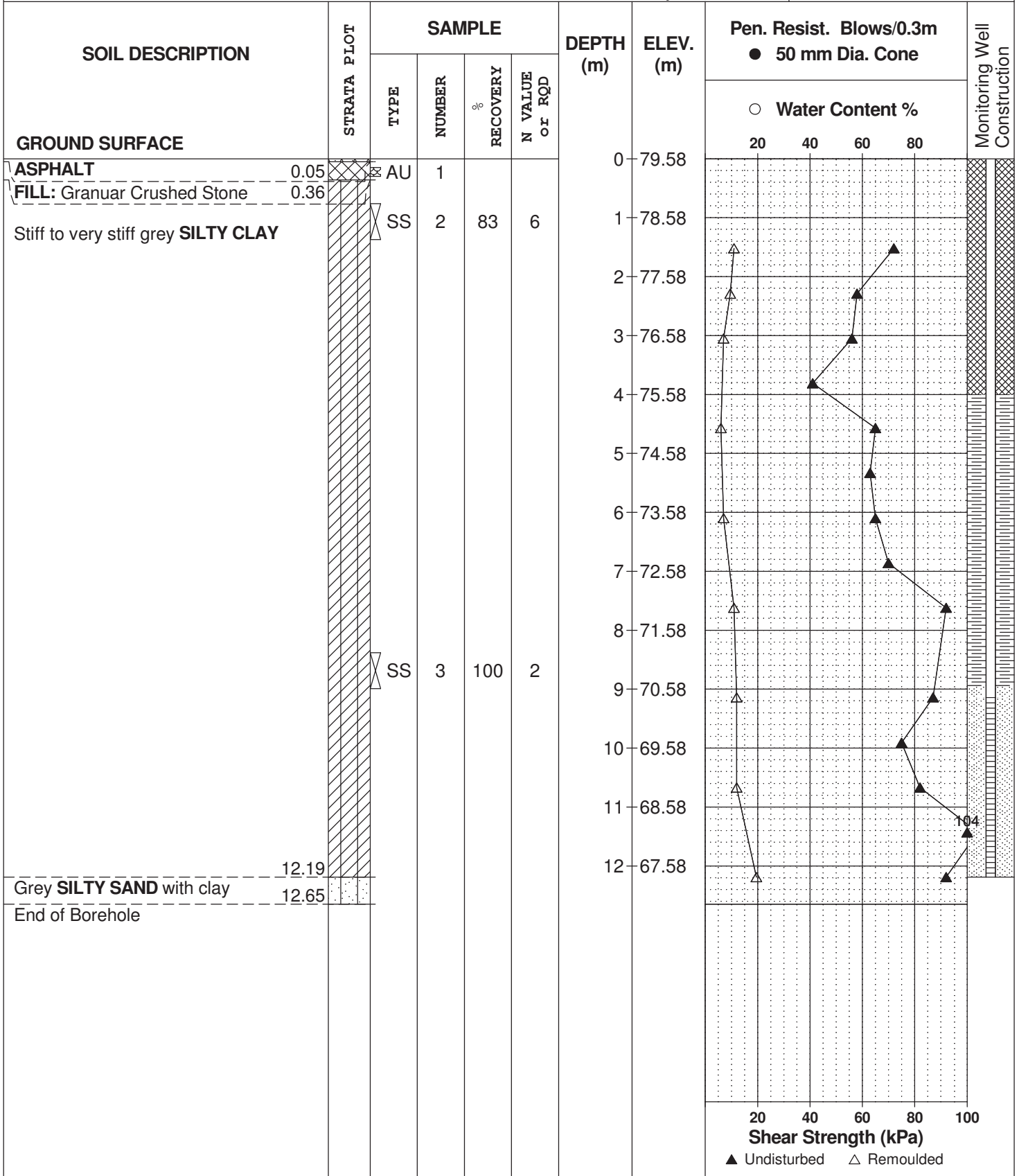

DATUM Geodetic

REMARKS

BORINGS BY CME-55 Low Clearance Drill

DATE 2022 February 8

FILE NO. **PG6107**

HOLE NO. **BH 2-22**

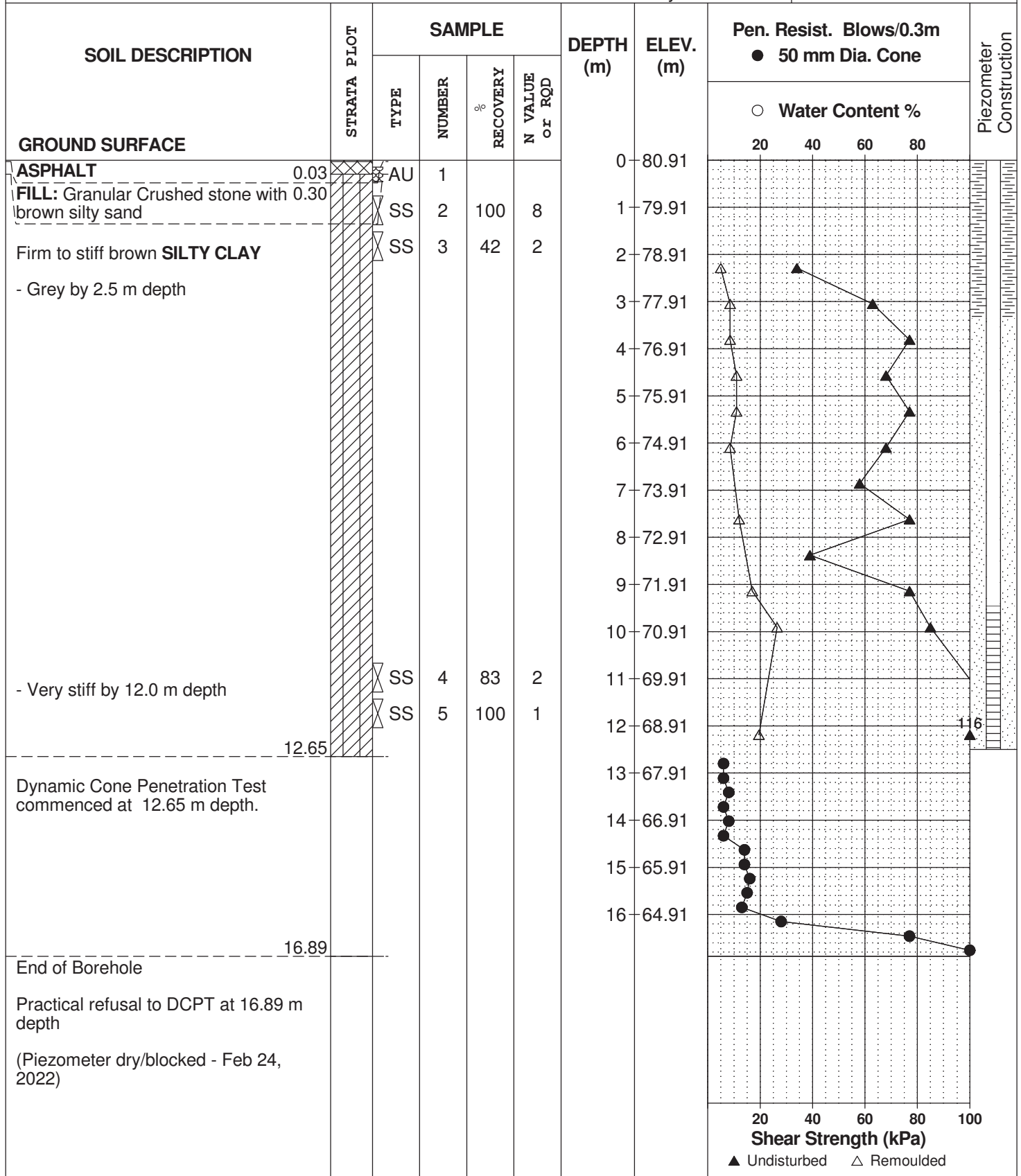

DATUM Geodetic

REMARKS

BORINGS BY CME-55 Low Clearance Drill

DATE 2022 February 9

FILE NO. **PG6107**

HOLE NO. **BH 3-22**

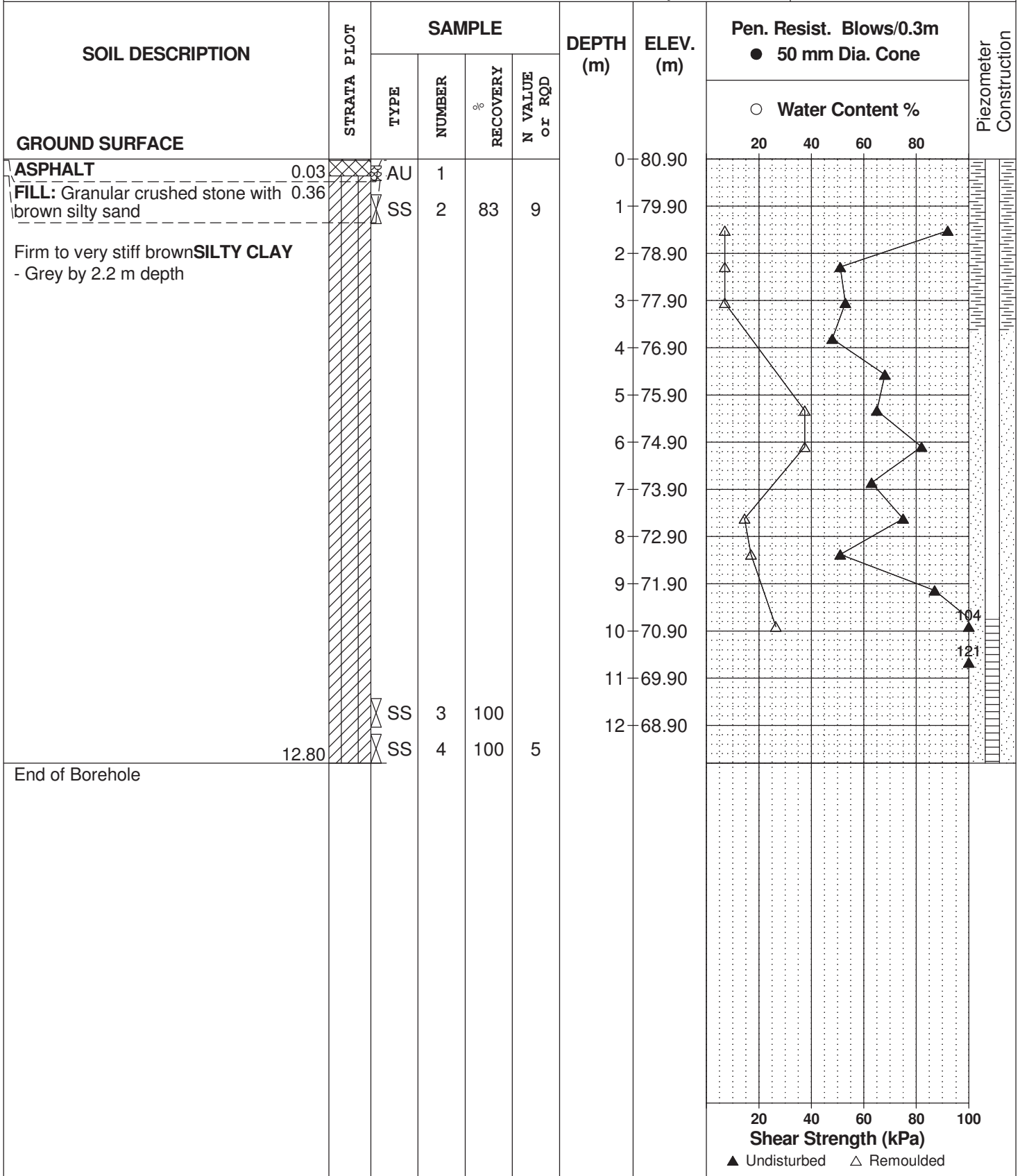

DATUM Geodetic

REMARKS

BORINGS BY CME-55 Low Clearance Drill

DATE 2022 February 9

FILE NO. **PG6107**

HOLE NO. **BH 4-22**

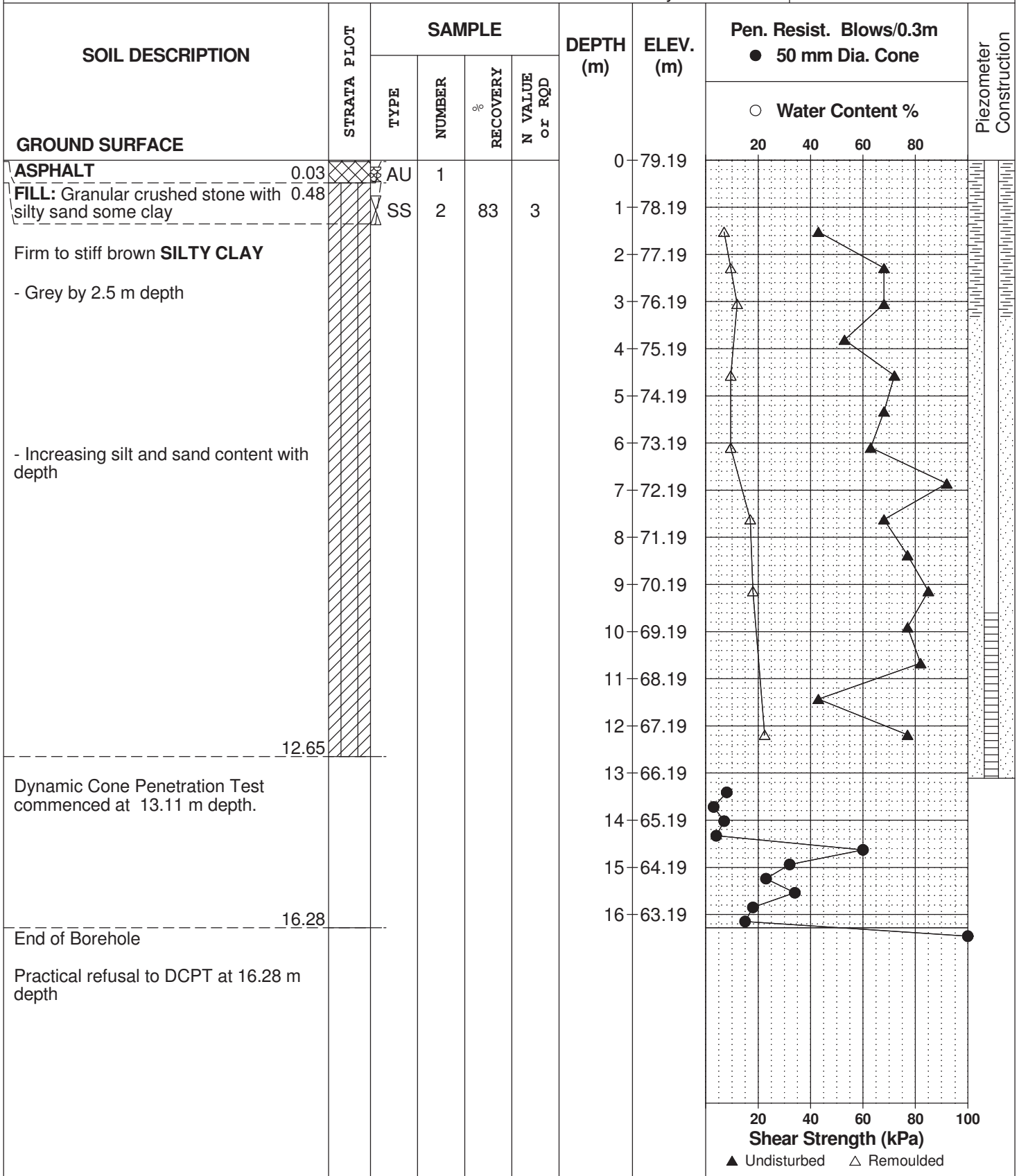

DATUM Geodetic

REMARKS

BORINGS BY CME-55 Low Clearance Drill

DATE 2022 February 10

FILE NO. **PG6107**

HOLE NO. **BH 5-22**

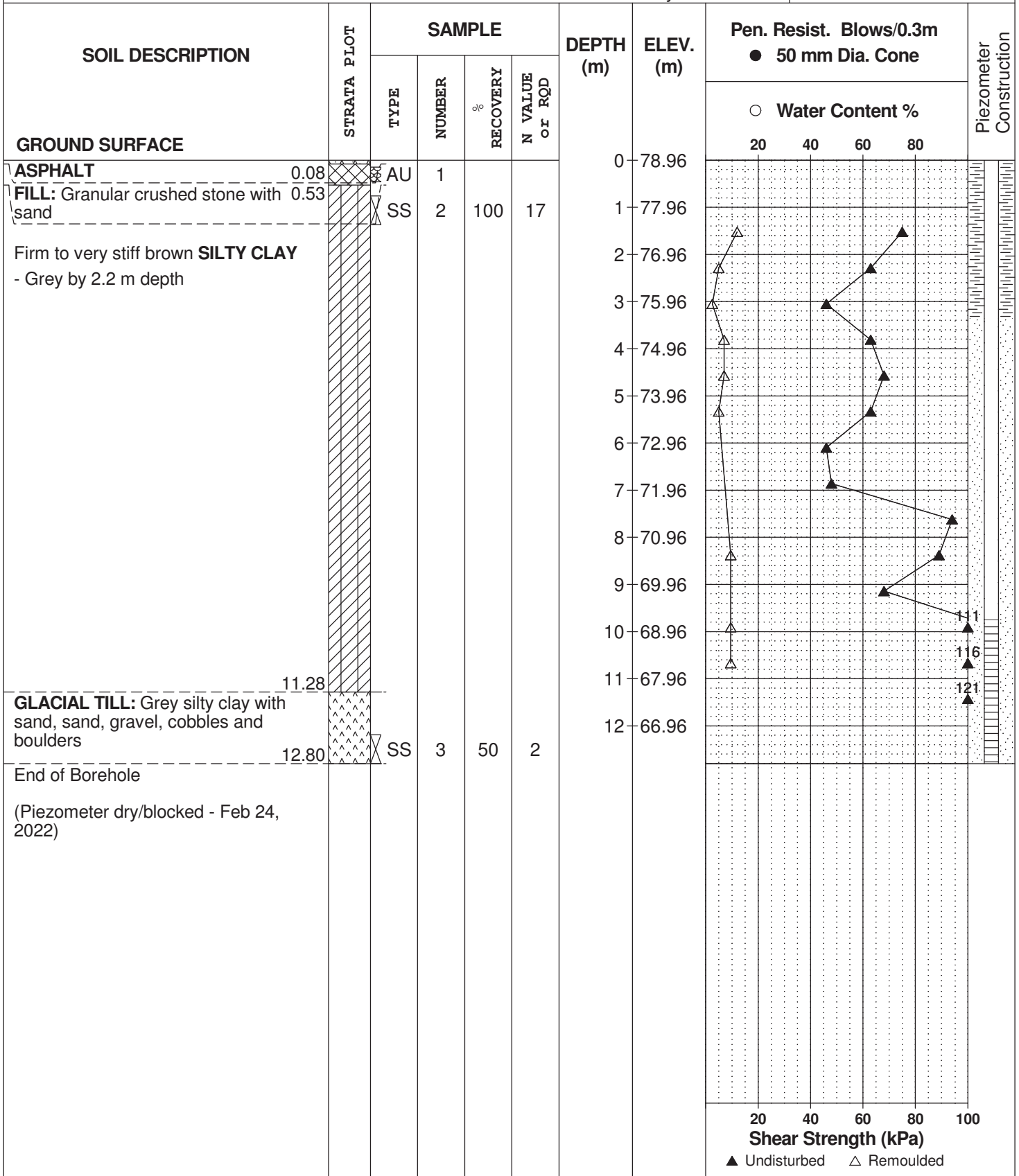

DATUM Geodetic

REMARKS

BORINGS BY CME-55 Low Clearance Drill

DATE 2022 February 10

FILE NO. **PG6107**

HOLE NO. **BH 6-22**

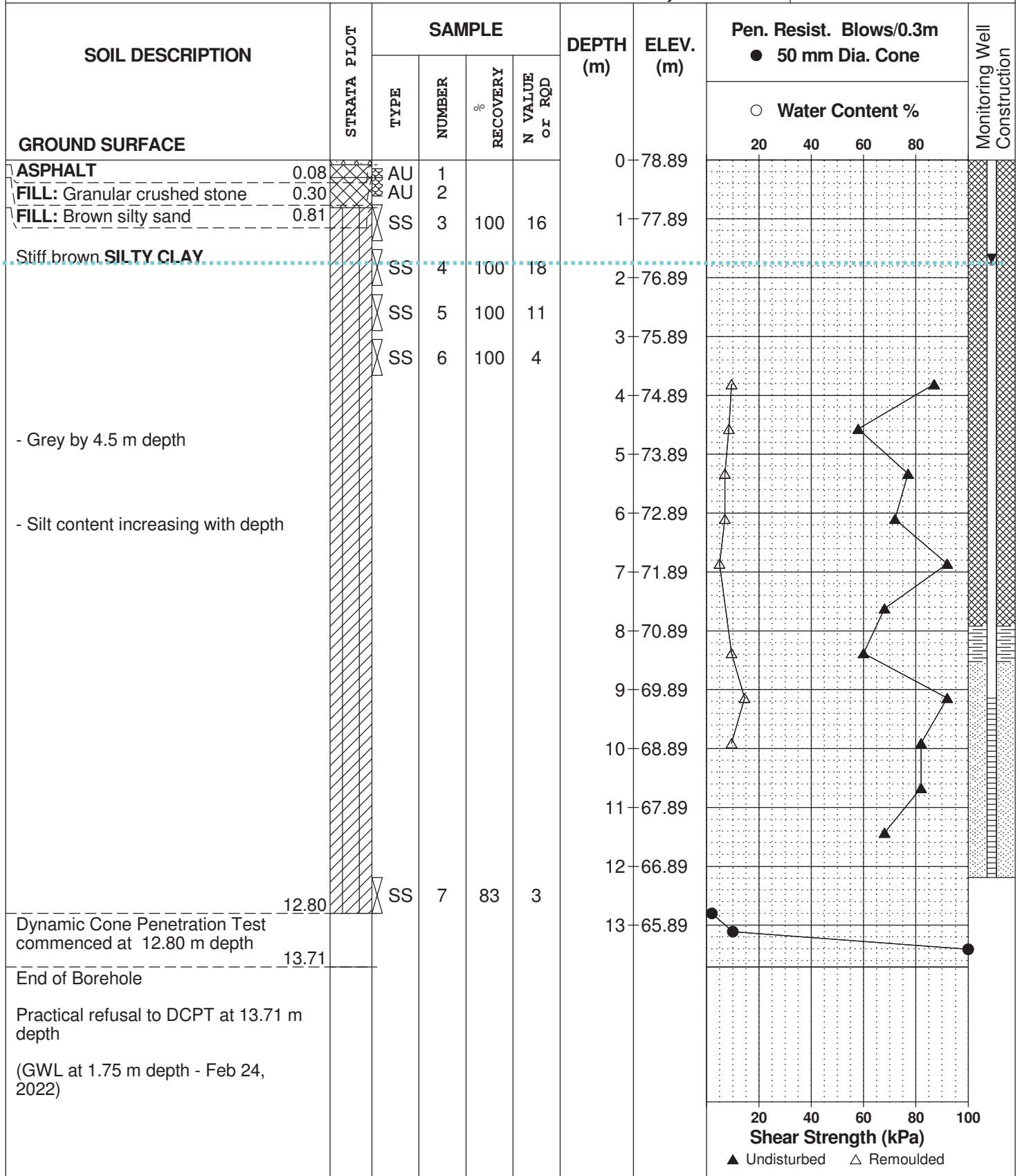

DATUM Geodetic

REMARKS

BORINGS BY CME-55 Low Clearance Drill

DATE 2022 February 11

FILE NO. **PG6107**

HOLE NO. **BH 7-22**

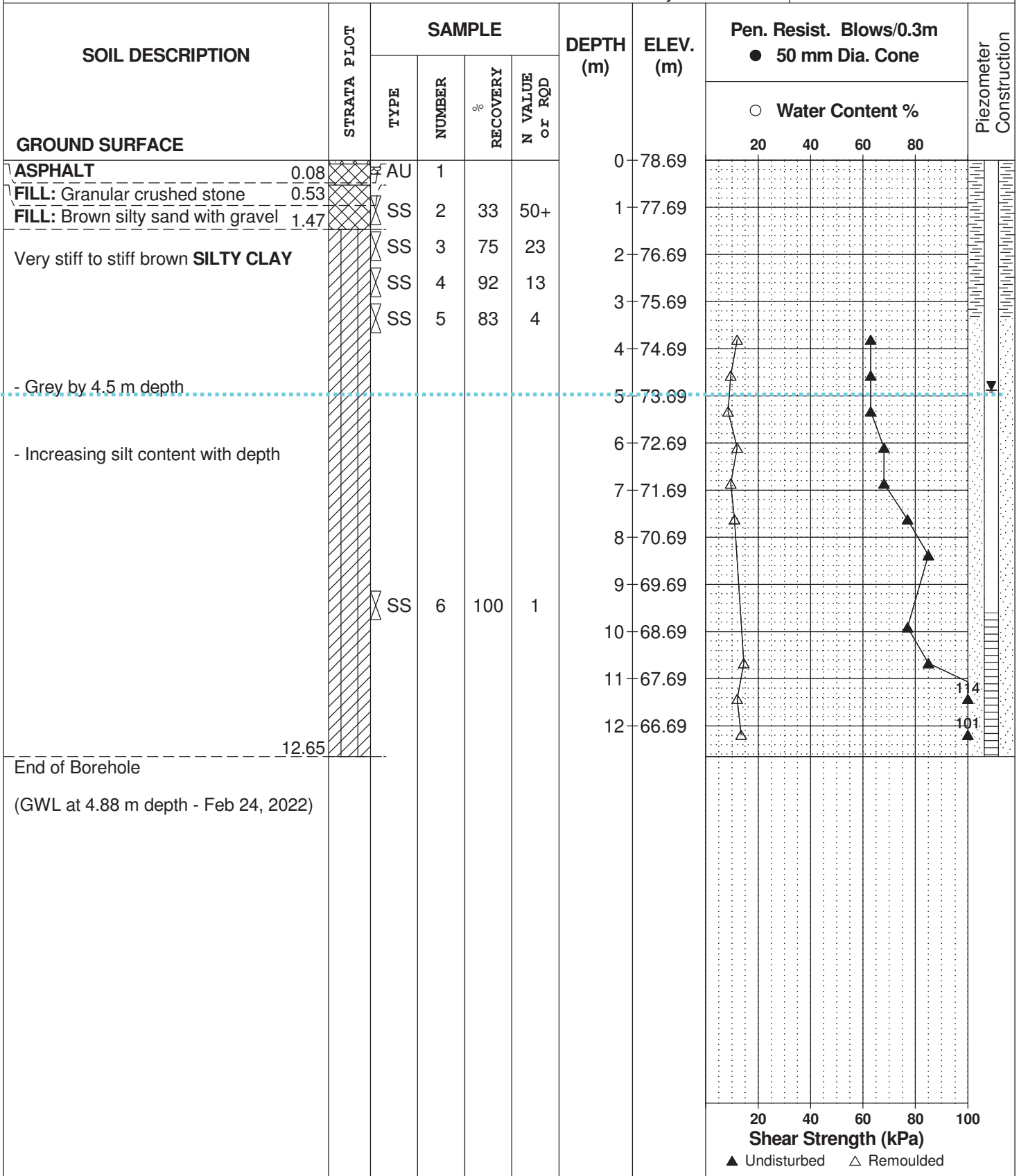



DATUM Geodetic

REMARKS

BORINGS BY CME-55 Low Clearance Drill

DATE 2022 February 11

FILE NO. **PG6107**

HOLE NO. **BH 8-22**

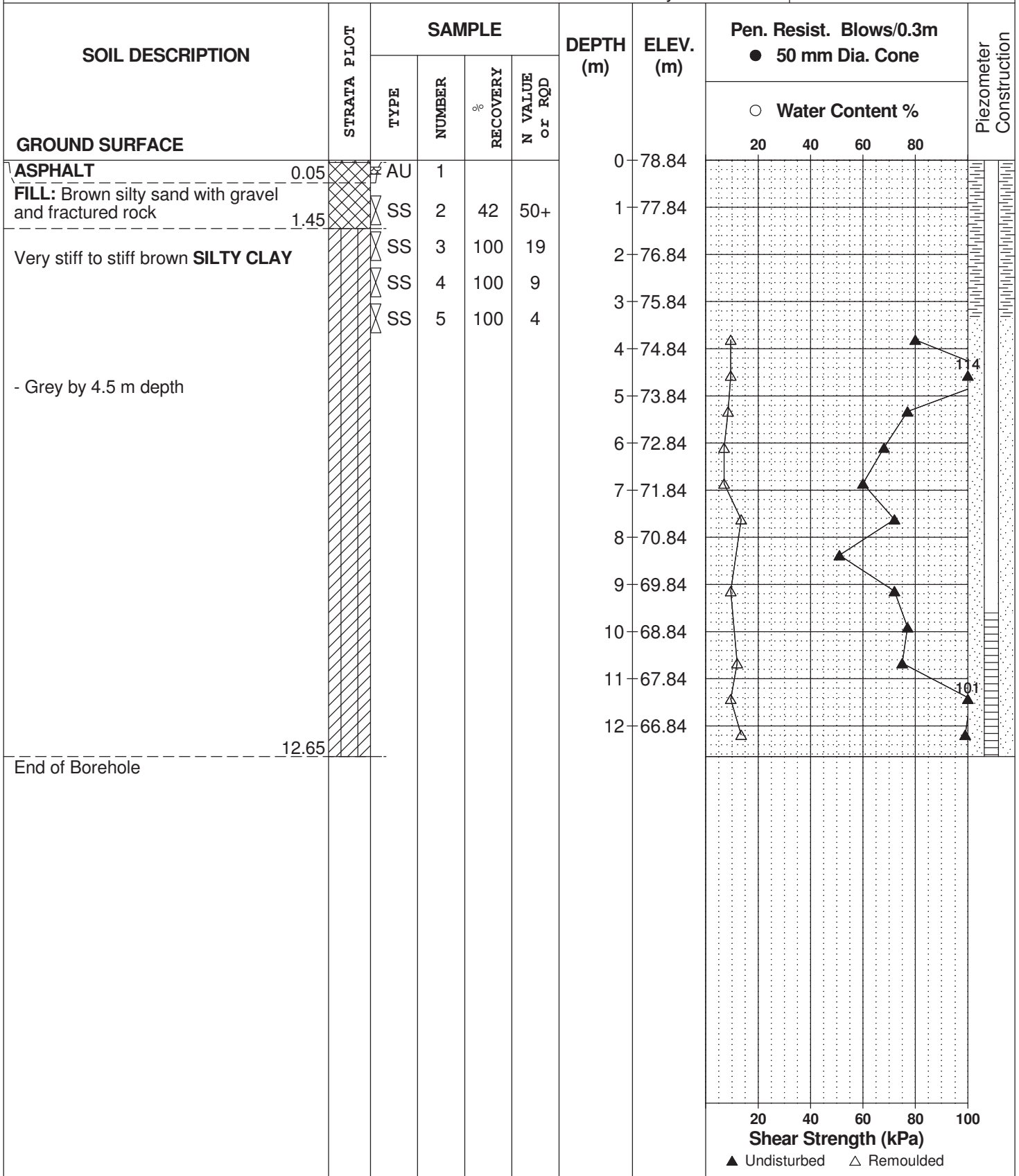

DATUM Geodetic

REMARKS

BORINGS BY CME-55 Low Clearance Drill

DATE 2022 February 14

FILE NO. **PG6107**

HOLE NO. **BH 9-22**

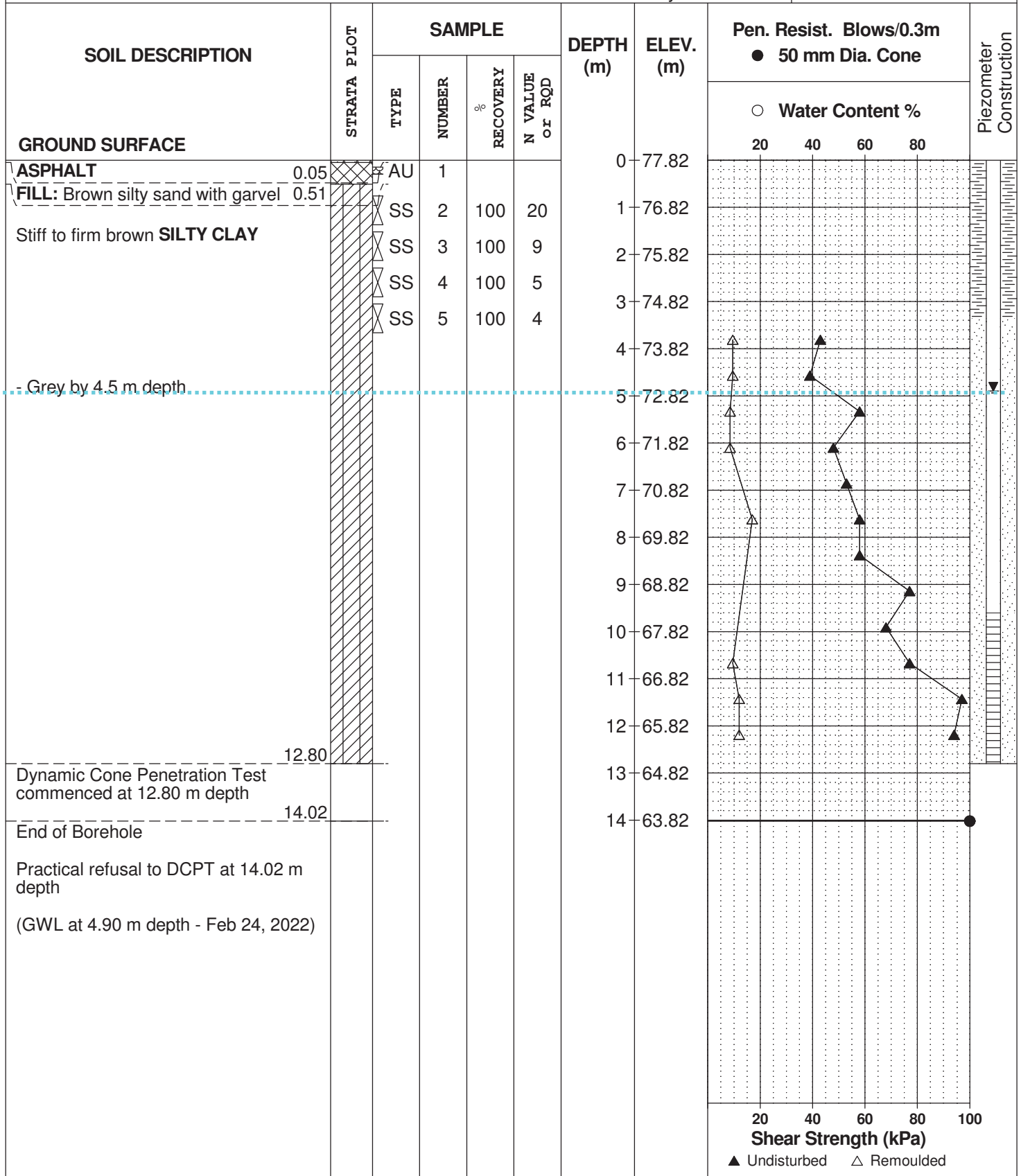

DATUM Geodetic

REMARKS

BORINGS BY CME-55 Low Clearance Drill

DATE 2022 February 14

FILE NO. **PG6107**

HOLE NO. **BH10-22**

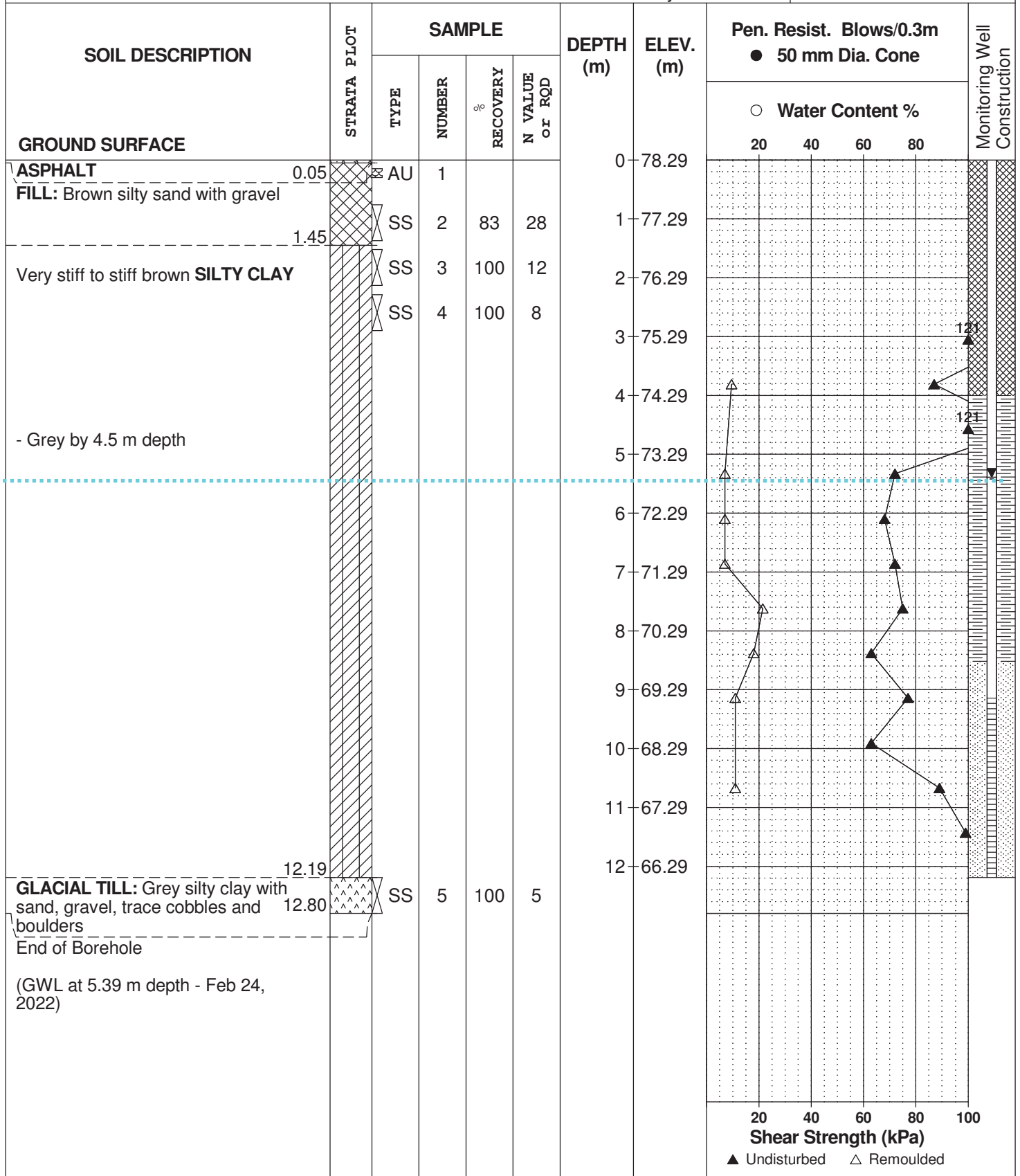

# SYMBOLS AND TERMS

## SOIL DESCRIPTION

Behavioural properties, such as structure and strength, take precedence over particle gradation in describing soils. Terminology describing soil structure are as follows:

Desiccated	-	having visible signs of weathering by oxidation of clay minerals, shrinkage cracks, etc.
Fissured	-	having cracks, and hence a blocky structure.
Varved	-	composed of regular alternating layers of silt and clay.
Stratified	-	composed of alternating layers of different soil types, e.g. silt and sand or silt and clay.
Well-Graded	-	Having wide range in grain sizes and substantial amounts of all intermediate particle sizes (see Grain Size Distribution).
Uniformly-Graded	-	Predominantly of one grain size (see Grain Size Distribution).

The standard terminology to describe the strength of cohesionless soils is the relative density, usually inferred from the results of the Standard Penetration Test (SPT) 'N' value. The SPT N value is the number of blows of a 63.5 kg hammer, falling 760 mm, required to drive a 51 mm O.D. split spoon sampler 300 mm into the soil after an initial penetration of 150 mm.

Relative Density	'N' Value	Relative Density %
Very Loose	<4	<15
Loose	4-10	15-35
Compact	10-30	35-65
Dense	30-50	65-85
Very Dense	>50	>85

The standard terminology to describe the strength of cohesive soils is the consistency, which is based on the undisturbed undrained shear strength as measured by the in situ or laboratory vane tests, penetrometer tests, unconfined compression tests, or occasionally by Standard Penetration Tests.

Consistency	Undrained Shear Strength (kPa)	'N' Value
Very Soft	<12	<2
Soft	12-25	2-4
Firm	25-50	4-8
Stiff	50-100	8-15
Very Stiff	100-200	15-30
Hard	>200	>30

## SYMBOLS AND TERMS (continued)

### SOIL DESCRIPTION (continued)

Cohesive soils can also be classified according to their "sensitivity". The sensitivity is the ratio between the undisturbed undrained shear strength and the remoulded undrained shear strength of the soil.

Terminology used for describing soil strata based upon texture, or the proportion of individual particle sizes present is provided on the Textural Soil Classification Chart at the end of this information package.

### ROCK DESCRIPTION

The structural description of the bedrock mass is based on the Rock Quality Designation (RQD).

The RQD classification is based on a modified core recovery percentage in which all pieces of sound core over 100 mm long are counted as recovery. The smaller pieces are considered to be a result of closely-spaced discontinuities (resulting from shearing, jointing, faulting, or weathering) in the rock mass and are not counted. RQD is ideally determined from NXL size core. However, it can be used on smaller core sizes, such as BX, if the bulk of the fractures caused by drilling stresses (called "mechanical breaks") are easily distinguishable from the normal in situ fractures.

<b>RQD %</b>	<b>ROCK QUALITY</b>
90-100	Excellent, intact, very sound
75-90	Good, massive, moderately jointed or sound
50-75	Fair, blocky and seamy, fractured
25-50	Poor, shattered and very seamy or blocky, severely fractured
0-25	Very poor, crushed, very severely fractured

### SAMPLE TYPES

SS	-	Split spoon sample (obtained in conjunction with the performing of the Standard Penetration Test (SPT))
TW	-	Thin wall tube or Shelby tube
PS	-	Piston sample
AU	-	Auger sample or bulk sample
WS	-	Wash sample
RC	-	Rock core sample (Core bit size AXT, BXL, etc.). Rock core samples are obtained with the use of standard diamond drilling bits.

## SYMBOLS AND TERMS (continued)

### GRAIN SIZE DISTRIBUTION

MC%	-	Natural moisture content or water content of sample, %
LL	-	Liquid Limit, % (water content above which soil behaves as a liquid)
PL	-	Plastic limit, % (water content above which soil behaves plastically)
PI	-	Plasticity index, % (difference between LL and PL)
Dxx	-	Grain size which xx% of the soil, by weight, is of finer grain sizes These grain size descriptions are not used below 0.075 mm grain size
D10	-	Grain size at which 10% of the soil is finer (effective grain size)
D60	-	Grain size at which 60% of the soil is finer
Cc	-	Concavity coefficient = $(D_{30})^2 / (D_{10} \times D_{60})$
Cu	-	Uniformity coefficient = $D_{60} / D_{10}$

Cc and Cu are used to assess the grading of sands and gravels:

Well-graded gravels have:  $1 < Cc < 3$  and  $Cu > 4$

Well-graded sands have:  $1 < Cc < 3$  and  $Cu > 6$

Sands and gravels not meeting the above requirements are poorly-graded or uniformly-graded.

Cc and Cu are not applicable for the description of soils with more than 10% silt and clay (more than 10% finer than 0.075 mm or the #200 sieve)

### CONSOLIDATION TEST

$p'_o$	-	Present effective overburden pressure at sample depth
$p'_c$	-	Preconsolidation pressure of (maximum past pressure on) sample
Ccr	-	Recompression index (in effect at pressures below $p'_c$ )
Cc	-	Compression index (in effect at pressures above $p'_c$ )
OC Ratio		Overconsolidation ratio = $p'_c / p'_o$
Void Ratio		Initial sample void ratio = volume of voids / volume of solids
Wo	-	Initial water content (at start of consolidation test)

### PERMEABILITY TEST

k	-	Coefficient of permeability or hydraulic conductivity is a measure of the ability of water to flow through the sample. The value of k is measured at a specified unit weight for (remoulded) cohesionless soil samples, because its value will vary with the unit weight or density of the sample during the test.
---	---	--

## SYMBOLS AND TERMS (continued)

### STRATA PLOT



Topsoil



Asphalt

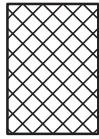

Fill



Peat

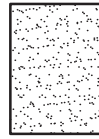

Sand

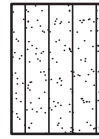

Silty Sand

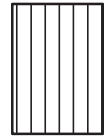

Silt

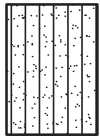

Sandy Silt

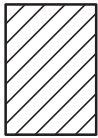

Clay

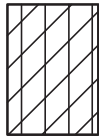

Silty Clay



Clayey Silty Sand



Glacial Till

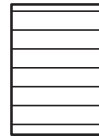

Shale

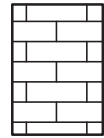

Bedrock

### MONITORING WELL AND PIEZOMETER CONSTRUCTION

#### MONITORING WELL CONSTRUCTION

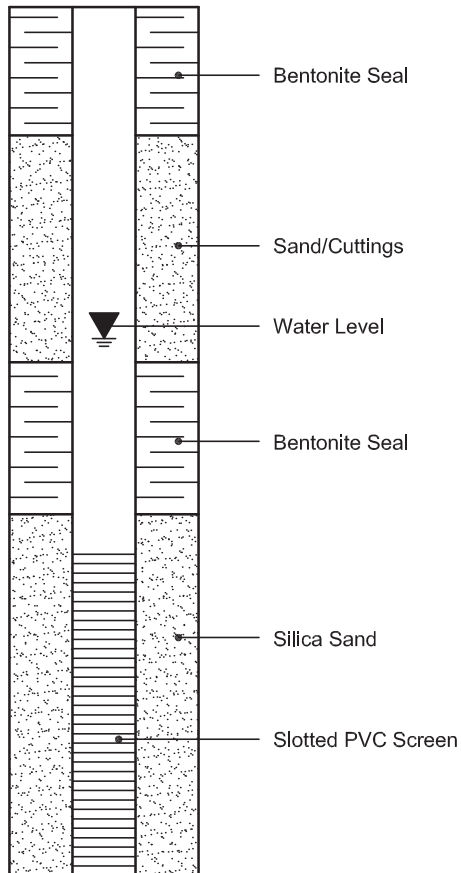

#### PIEZOMETER CONSTRUCTION

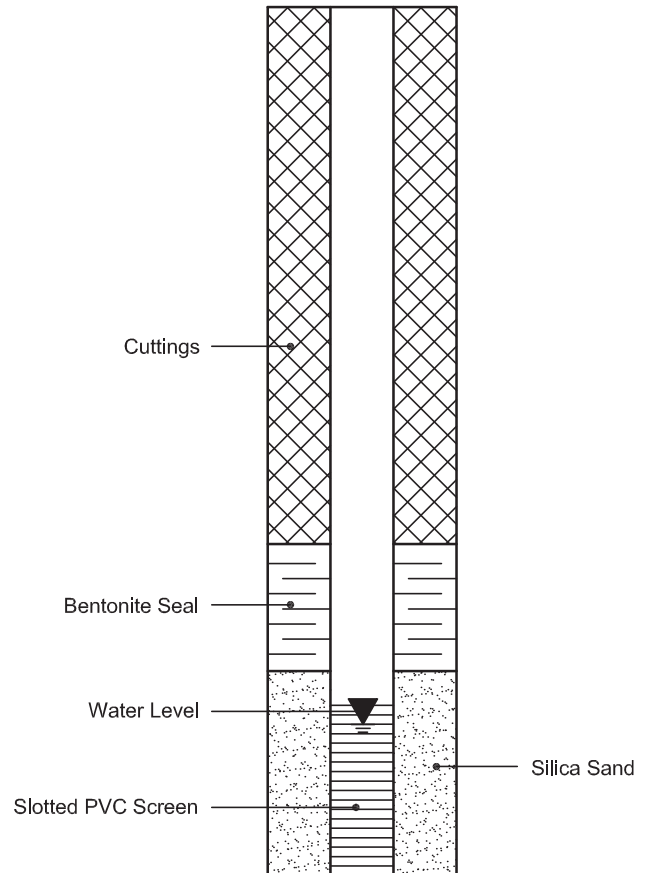

**LOG OF BOREHOLE BH13-7**

PROJECT: Brigil 2940 Baseline Road  
 CLIENT: Brigil Platinum  
 PROJECT LOCATION: 2940-2948 Baseline Road  
 DATUM: Geodetic  
 BH LOCATION: See Borehole Location Plan

**DRILLING DATA**  
 Method: Hollow Stem Augers  
 Diameter: 203mm  
 Date: May/07/2013  
 REF. NO.: 1599-710  
 ENCL NO.:

SOIL PROFILE		SAMPLES			GROUND WATER CONDITIONS	ELEVATION	DYNAMIC CONE PENETRATION RESISTANCE PLOT				POCKET PEN. (Cu) (kPa)	NATURAL UNIT WT (kN/m <sup>3</sup> )	REMARKS AND GRAIN SIZE DISTRIBUTION (%)				
(m) ELEV	DESCRIPTION	NUMBER	TYPE	"N" BLOWS 0.3 m			20	40	60	80				100	PLASTIC LIMIT W <sub>p</sub>	NATURAL MOISTURE CONTENT W	LIQUID LIMIT W <sub>L</sub>
77.7	Asphalt 125 mm																
77.6	Sandy Silt some clay, brown, damp, loose (Fill)	1	SS	9													
		2	SS	9													
76.2	Silty Clay trace sand, brown, moist, stiff	3	SS	10							o						
1.5		4	SS	4							o						
	- grey below 3.7 m	5	SS	2							o						
	- wet below 4.5 m	6	SS	1							o						
		7	SS	WH							o						
			VANE														
			VANE														
		8	SS	WH							o						
			VANE														
			VANE														
		9	SS	WH							o						
69.5	END OF BOREHOLE																
8.2	Notes: 1) 50mm dia. monitoring well installed upon completion 2) Depth of Water  Date      Depth 14/05/2013    2.7 m BSL																

GRAPH NOTES + 3, x 3: Numbers refer to Sensitivity      o s=3% Strain at Failure

SPL SOIL LOG 1599-710.GPJ SPL.GDT 23/5/13



**LOG OF BOREHOLE BH13-8**

PROJECT: Brigil 2940 Baseline Road	DRILLING DATA
CLIENT: Brigil Platinum	Method: Hollow Stem Augers
PROJECT LOCATION: 2940-2948 Baseline Road	Diameter: 203mm
DATUM: Geodetic	Date: Feb/05/2013
BH LOCATION: See Borehole Location Plan	REF. NO.: 1599-710
	ENCL NO.:

SOIL PROFILE			SAMPLES			GROUND WATER CONDITIONS	ELEVATION	DYNAMIC CONE PENETRATION RESISTANCE PLOT					POCKET PEN. (Cu) (kPa)	NATURAL UNIT WT (kN/m <sup>3</sup> )	REMARKS AND GRAIN SIZE DISTRIBUTION (%)			
(m) ELEV DEPTH	DESCRIPTION	STRATA PLOT	NUMBER	TYPE	"N" BLOWS 0.3 m			20	40	60	80	100				PLASTIC LIMIT W <sub>p</sub>	NATURAL MOISTURE CONTENT W	LIQUID LIMIT W <sub>L</sub>
79.7																		
0.0	<b>Sand and Gravel</b> trace clay, grey, damp, firm (Fill)	○	1	SS	7						○							43 44 13
79.0																		
0.8	<b>Silty Clay</b> trace gravel, grey, moist, firm	○	2	SS	7							○						
	- 32.5 mm gravel lens	○	3	SS	8							○						
77.9																		
1.8	<b>END OF BOREHOLE</b>																	

SPL SOIL LOG 1599-710.GPJ SPL.GDT 23/5/13

**GRAPH NOTES** +<sup>3</sup>, ×<sup>3</sup>: Numbers refer to Sensitivity      ○ = 3% Strain at Failure

**LOG OF BOREHOLE BH13-9**

PROJECT: Brigil 2940 Baseline Road CLIENT: Brigil Platinum PROJECT LOCATION: 2940-2948 Baseline Road DATUM: Geodetic BH LOCATION: See Borehole Location Plan	<b>DRILLING DATA</b> Method: Hollow Stem Augers Diameter: 203mm Date: May/07/2013 REF. NO.: 1599-710 ENCL NO.:
--	---

SOIL PROFILE			SAMPLES			GROUND WATER CONDITIONS	ELEVATION	DYNAMIC CONE PENETRATION RESISTANCE PLOT					PLASTIC NATURAL LIQUID LIMIT MOISTURE CONTENT			POCKET PEN. (Cu) (kPa)	NATURAL UNIT WT (kN/m <sup>3</sup> )	REMARKS AND GRAIN SIZE DISTRIBUTION (%)	
(m) ELEV DEPTH	DESCRIPTION	STRATA PLOT	NUMBER	TYPE	"N" BLOWS 0.3 m			20	40	60	80	100	W <sub>p</sub>	w	W <sub>L</sub>				GR
78.6	<b>Asphalt 50 mm</b>																		
78.0	<b>Sand Gravel</b> some gravel, some organics, brown, damp (Fill)		1	AS													18	66	16
77.6	<b>Sand and Gravel</b> brown, damp (Fill)		2	AS															
77.1	<b>END OF BOREHOLE</b>																		
1.5																			

SPL SOIL LOG 1599-710.GPJ SPL.GDT 23/5/13

**GRAPH NOTES** +<sup>3</sup>, ×<sup>3</sup>: Numbers refer to Sensitivity      ○ ●=3% Strain at Failure

PROJECT: Brigil 2940 Baseline Road CLIENT: Brigil Platinum PROJECT LOCATION: 2940-2948 Baseline Road DATUM: Geodetic BH LOCATION: See Borehole Location Plan	<b>DRILLING DATA</b> Method: Hollow Stem Augers Diameter: 203mm Date: May/07/2013 REF. NO.: 1599-710 ENCL NO.:
--	---

SOIL PROFILE		SAMPLES			GROUND WATER CONDITIONS	ELEVATION	DYNAMIC CONE PENETRATION RESISTANCE PLOT					POCKET PEN. (Cu) (kPa)	NATURAL UNIT WT (kN/m <sup>3</sup> )	REMARKS AND GRAIN SIZE DISTRIBUTION (%)				
(m) ELEV DEPTH	DESCRIPTION	STRATA PLOT	NUMBER	TYPE			"N" BLOWS 0.3 m	SHEAR STRENGTH (kPa)							WATER CONTENT (%)			
							20	40	60	80	100	W <sub>p</sub>	W	W <sub>L</sub>	GR	SA	SI	CL
77.5	Asphalt 100 mm																	
76.9 0.1	Gravelly Sand some silt, brown, damp (Fill)		1	AS	15										30	54		16
76.1 1.4	END OF BOREHOLE																	

SPL SOIL LOG 1599-710.GPJ SPL.GDT 23/5/13

Certificate of Analysis

Report Date: 22-Feb-2022

Client: Paterson Group Consulting Engineers

Order Date: 15-Feb-2022

Client PO: 33745

Project Description: PG6107

<b>Client ID:</b>	BH8-22 - SS4	-	-	-
<b>Sample Date:</b>	11-Feb-22 09:00	-	-	-
<b>Sample ID:</b>	2208197-01	-	-	-
<b>MDL/Units</b>	Soil	-	-	-

**Physical Characteristics**

% Solids	0.1 % by Wt.	74.4	-	-	-
----------	--------------	------	---	---	---

**General Inorganics**

pH	0.05 pH Units	7.29	-	-	-
Resistivity	0.10 Ohm.m	24.0	-	-	-

**Anions**

Chloride	5 ug/g dry	174	-	-	-
Sulphate	5 ug/g dry	93	-	-	-

# APPENDIX 2

FIGURE 1 – KEY PLAN

FIGURE 2 – WATER SUPPRESSION SYSTEM

FIGURE 3 – ELEVATOR PIT WATERPROOFING

DRAWING PG6107-1 - TEST HOLE LOCATION PLAN

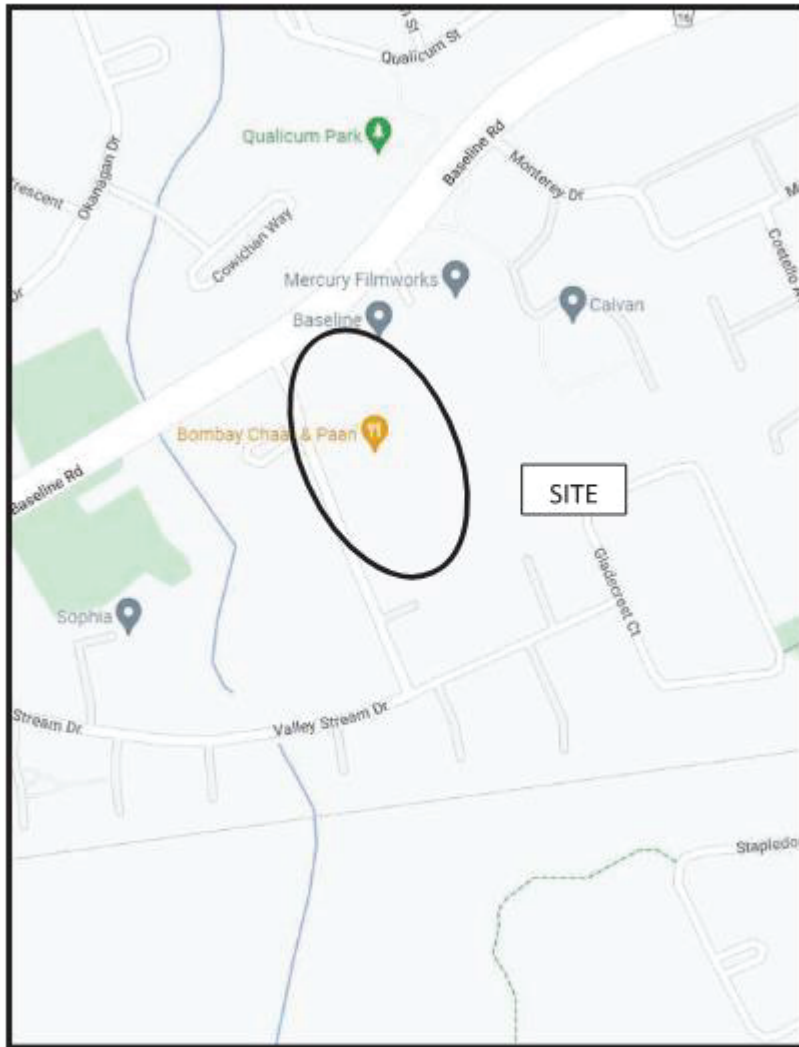

# FIGURE 1

## KEY PLAN

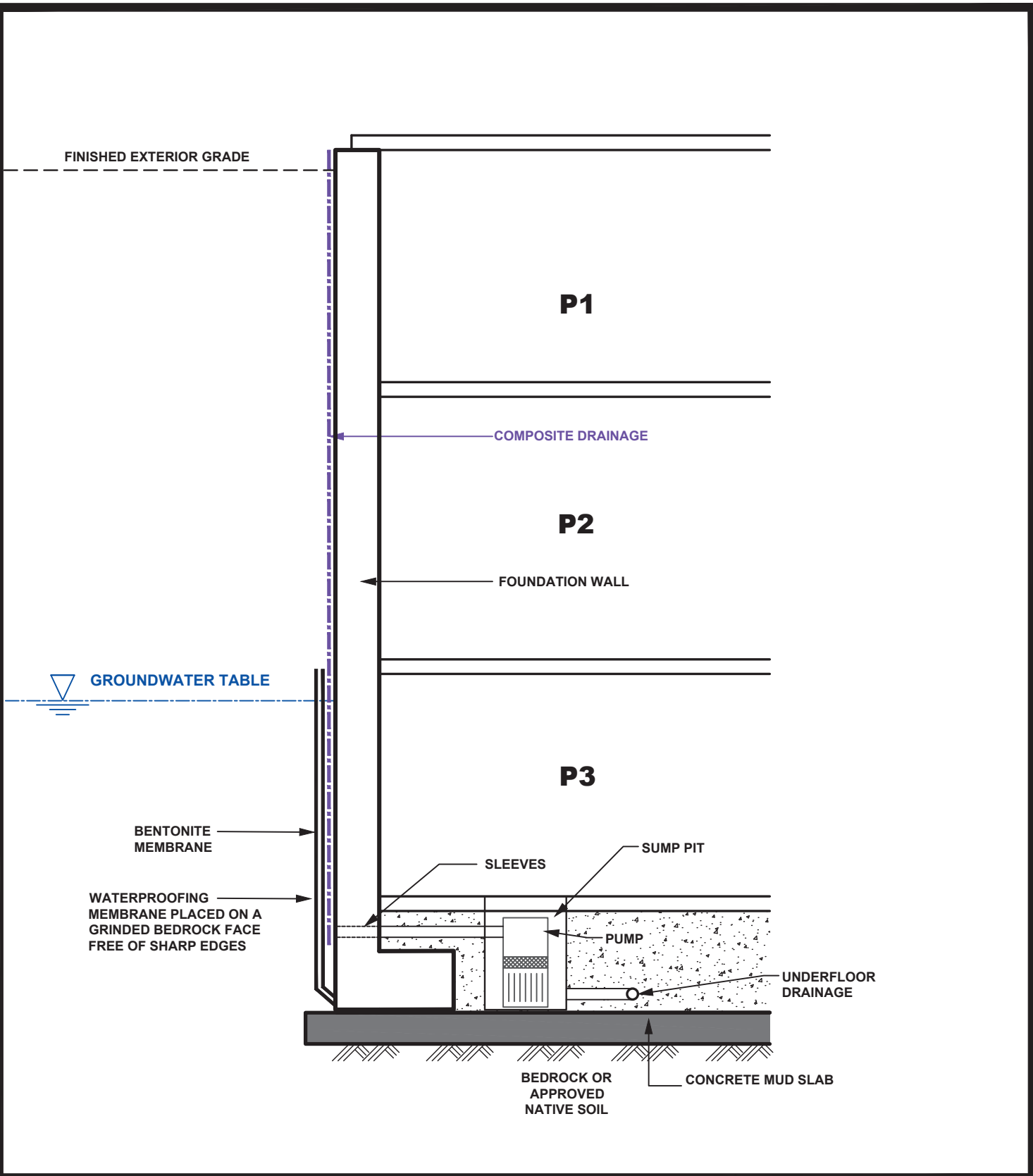

**patersongroup**  
 consulting engineers

154 Colonnade Road South  
 Ottawa, Ontario K2E 7J5  
 Tel: (613) 226-7381 Fax: (613) 226-6344  
 www.patersongroup.ca

**BRIGIL CONSTRUCTION**

GEOTECHNICAL INVESTIGATION  
 2946 BASELINE ROAD  
 OTTAWA, ONTARIO

Title: **WATER SUPPRESSION SYSTEM**

Date: 03/2023

Scale: N.T.S.

Drawn by: NFRV

Checked by: BN

Report No.: PG6107-1

Drawing No.: **FIGURE 2**

NOTES:

- IT IS RECOMMENDED THAT PERIODIC INSPECTIONS BE COMPLETED BY PATERSON PERSONNEL AT THE TIME OF CONSTRUCTION DURING THE INSTALLATION OF THE ELEVATOR WATERPROOFING MEMBRANE(S).

XYPEX CONCRETE ADDITIVE (OPTIONAL)

PROTECTION BOARD - IKO  
PROTECTION BOARD OR  
APPROVED OTHER

ELEVATOR PIT BACKFILLED WITH  
MIN. 15 MPa LEAN CONCRETE,  
OPSS GRANULAR B TYPE II OR  
GRANULAR A CRUSHED STONE

150 mm PERFORATED CORRUGATED PIPE  
(MAY BE OMITTED IF BACK FILLED WITH  
LEAN CONCRETE) WITH GRAVITY  
CONNECTION TO SUMP PUMP BASIN

WATERPROOFING MEMBRANE COLPHENE  
TORCHN STICK OR APPROVED OTHER

ELEVATOR DRAIN AS PER MECHANICAL,  
GRAVITY CONNECTION TO THE ELEVATOR  
SUMP BASIN

XYPEX CONCRETE ADDITIVE  
(OPTIONAL)

CONCRETE BASE SLAB

LEAN CONCRETE FILL

75mm MUD SLAB

SURFACE SOUNDED BEDROCK OR NATIVE SOIL  
APPROVED BY GEOTECHNICAL CONSULTANT

CONTINUOUS PVC WATERSTOP,  
SOUTHERN WATERSTOP 14RCB  
OR APPROVED OTHER

PILE

PILE

PILE

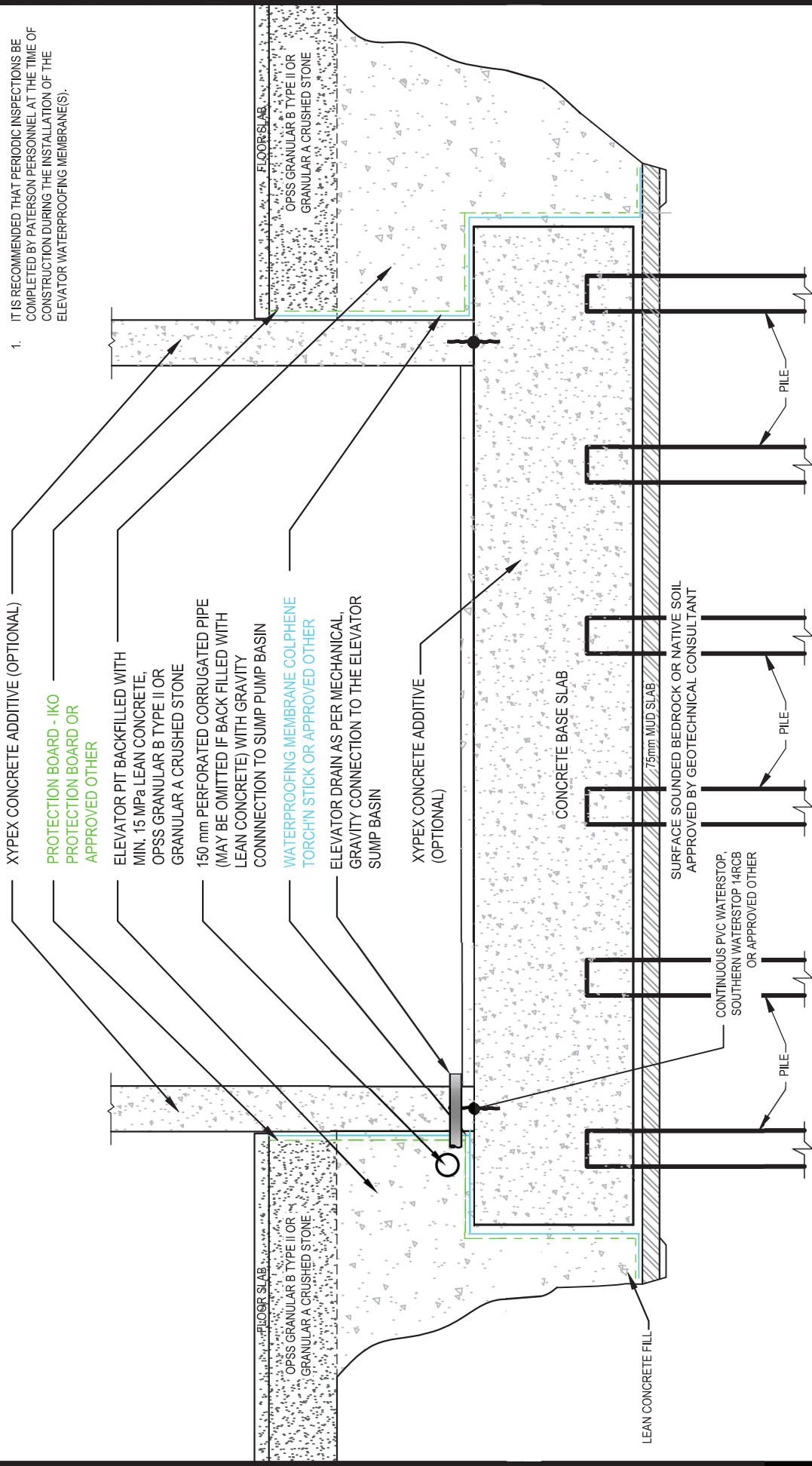

Scale:	N.T.S.	Date:	03/2023
Drawn by:	NFRV	Report No.:	PG6107
Checked by:	JV	Drawing No.:	<b>FIGURE 3</b>
Approved by:	DJG	Revision No.:	

BIRGIL CONSTRUCTION  
**PROPOSED MULTI-STORY BUILDING**  
**2946 BASELINE ROAD**  
 ONTARIO  
 OTTAWA,  
 Title:



9 AURICA DRIVE  
OTTAWA, ON  
K2E 7T9  
TEL: (613) 226-7381



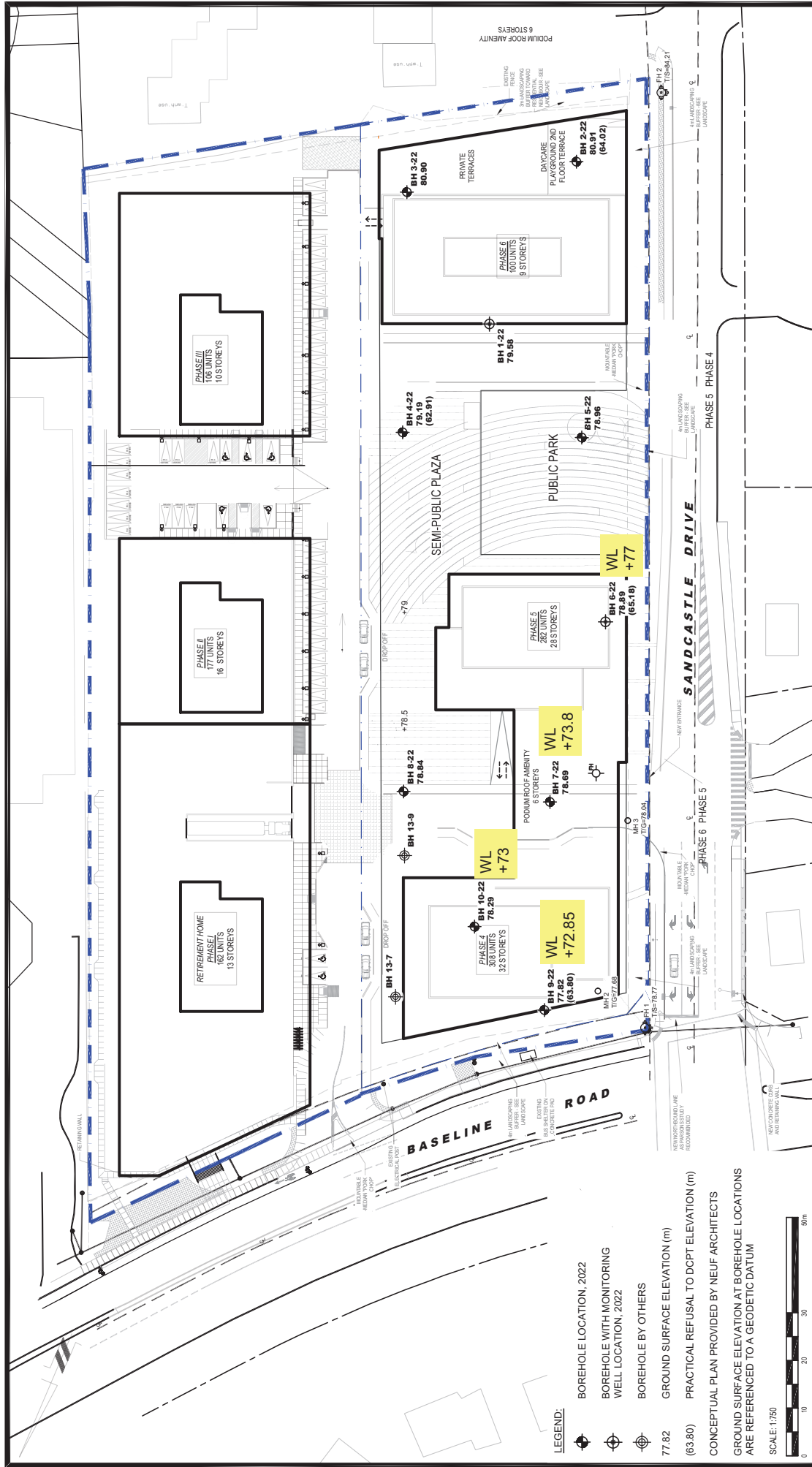

**LEGEND:**

- BOREHOLE LOCATION, 2022
- BOREHOLE WITH MONITORING WELL LOCATION, 2022
- BOREHOLE BY OTHERS
- GROUND SURFACE ELEVATION (m)
- PRACTICAL REFUSAL TO DCPPT ELEVATION (m)

CONCEPTUAL PLAN PROVIDED BY NEUF ARCHITECTS  
 GROUND SURFACE ELEVATION AT BOREHOLE LOCATIONS ARE REFERENCED TO A GEODETIC DATUM



<b>PATERSON GROUP</b> 9 AVENUE PARK OTTAWA, ON TEL: (613) 225-2339		BRIGIL CONSTRUCTION GEOTECHNICAL INVESTIGATION PROPOSED RESIDENTIAL BUILDING 2946 BASELINE ROAD OTTAWA, ONTARIO		Date: 02/2022 Report No.: PG6107-1 Dwg. No.: PG6107-1 Approved by: FA Checked by: BN Drawn by: YA Scale: 1:750
		<b>TEST HOLE LOCATION PLAN</b>		Title:
NO.	REVISIONS	DATE	INITIAL	
1	UPDATED TO NEW CONCEPTUAL PLAN	09/03/2023	JV	

# APPENDIX 3

## TYPICAL FOUNDATION SLEEVE INSTALLATION

Photo 1 – Step 1: It is recommended that the upper 1/3 of the 150 mm drainage sleeve be cut at a 45 degree angle to hydraulically connect the composite foundation drainage board to the interior and underfloor drainage system.



Photo 2 – Step 2: It is recommended that the 150 mm diameter drainage sleeve be installed by carefully cutting an 'X' shaped incision through the composite foundation drainage and inserting the 150 mm diameter drainage sleeve inside the 'X' by pulling the four (4) triangular flaps towards the installer.



Photo 3 – Step 3: Apply a suitable primer prior to the placement of the adhesive tape such as 3M tape, WP200 BlueSkin or equivalent.



Photo 4 – Step 4: An adhesive such as 3M tape, BlueSkin, or equivalent be utilized to seal the 150 mm drainage sleeve to the composite foundation drainage board to act as a barrier in preventing concrete from blocking connection during the placement of the exterior concrete foundation wall.



Photo 5 – Step 5: As an additional precaution, it is also recommended that an adhesive tape be placed on the interior outlet end of the drainage sleeve between the temporary form work to further prevent concrete from entering the drainage sleeve during the placement of concrete. Once the temporary form work has been removed, the adhesive tape can be cut away to allow groundwater to have a positive gravity connection to the interior perimeter and underfloor drainage system.



# Appendix F Pre-consultation



**ADDRESS: 2946 Baseline Road**  
**Pre-Consultation Meeting Minutes**  
**Meeting Date: May 27, 2021**

Attendee	Role	Organization
Lisa Stern	Planner	City of Ottawa
Jessica Valic	Engineering Project Manager	
Louise Cervený	Parks Planner	
Mike Giampa	Transportation Project Manager	
Christopher Moise	Urban Designer	
Timothy Beed	Planner	Fotenn
Jean-Luc Rivard	Landowner	Brigil
Philip Thibert		

**Comments from the Applicant:**

- 3 towers (18 storeys, 15 storeys and 6 storeys) on 4-storey podiums, commercial proposed at grade along Baseline.
- Parkades may be provided above ground in the podium and wrapped.

**Planning Comments:**

1. The application will require a rezoning and complex site plan application. The application form, timeline and fees can be found [here](#).
2. The site is within the General Urban Area. The site was rezoned in 2014 to GM[2138]S325-h. I have attached the report for your review. The zone permits an 8 storey residential building and two two-storey non-residential buildings subject to a holding provision. The holding provision contains requirements for: urban design, access, sanitary flows and Section 37.
3. Design Guidelines for High-rise buildings, Transit Oriented Development and Bird Friendly Guidelines apply.
4. The site is located on the south side of Baseline Road east of the Queensway Carleton Hospital. A future BRT station is identified at Baseline and the Hospital.
5. Please ensure that you are aware of the direction of the Draft Official Plan. It is expected that the draft Official Plan will be brought forward to Council for adoption in Fall 2021.
6. Section 37 will be required in accordance with the existing zone.
7. The connectivity within and through the site is consistent with the direction provided with the rezoning in 2014 and appreciated.
8. The provision of commercial space adjacent to Baseline Road is appreciated.
9. The Planning Rationale should discuss the existing and planned context of the area and compatibility with existing residential uses north of Baseline Road, west of Sandcastle and south of the site.
10. The height of the 20 storey building and heights of the podiums should be discussed in the Planning Rationale to ensure that they are compatible with surrounding development and support a pedestrian oriented and pleasant public realm.
11. The integration of the proposed buildings with the public realm (including private roadways through the site) should be discussed in the Planning Rationale. Please ensure that lower levels

of the building have a high percentage of glazing, landscaping and street trees are provided, and the building facing Baseline should have direct entrances from Baseline Road.

12. If parking is provided within the podium, please discuss the approach to mitigating impacts on the public realm. To ensure a pedestrian oriented public realm it would be effective to wrap the building around the parkade.
13. Please consider the placement of the parking garage entrances on the public realm/pedestrian movements.
14. The provision of a plaza is appreciated and consistent with the objectives for the site identified with the 2014 rezoning. Please discuss the design intent for this space and integration of the proposed development with this amenity area in the Planning Rationale.
15. Cash-in-lieu of parkland and associated appraisal fee will be required as a condition of approval as per the [Parkland Dedication Bylaw](#).
16. Please consult with the Ward Councillor prior to submission.

### **Urban Design:**

1. This proposal does not reside within one of the City's Design Priority Areas and need not attend the City's UDRP.
2. We have the following issues/questions about the current design:
  - a. The site layout seems to touch on a number of items that may satisfy the holding provision however the design needs to be developed further to better understand how it will meet those conditions;
  - b. We recommend that additional analysis illustrate how the high-rise locations and design meet transition measures, tower separation and building design outlined in the City's high-rise guidelines;
  - c. We are happy to review any design development details prior to full submission when changes to the design become more complicated and expensive;
3. A Design Brief is a required submittal for all Site Plan/Re-zoning applications. Please see the Design Brief Terms of Reference.
4. This is an exciting project in an area full of potential. We look forward to helping you achieve its goals with the highest level of design resolution. We are happy to assist and answer any questions regarding the above.

### **Engineering:**

#### **Water**

##### Available Watermain

- 203mm (DI) – Sandcastle Dr
  - 1220mm (C01) – Baseline Rd (Backbone Watermain)
1. As a local watermain is available for connection, connect to WM on Sandcastle Dr, not Baseline. Connections to backbone watermains are to be avoided where other alternatives are available.
  2. Per WDG 4.3.1, where basic demand is greater than 50 m<sup>3</sup>/day, there shall be a minimum of two water services, separated by an isolation valve, to avoid creation of vulnerable service area.
  3. Per WDG 4.4.7.2, District Meter Area (DMA) Chamber is required for services greater than 150mm in diameter.

##### Boundary Conditions

Request prior to first submission. Contact assigned City Infrastructure Project Manager with the following information:



1. Location of service(s)
2. Type of development
3. Fire flow (per FUS method – include FUS calculation sheet with boundary condition request – boundary conditions will not be requested without fire flow calculations)
4. Average Daily Demand (l/s)
5. Maximum Hourly Demand (l/s)
6. Maximum Daily Demand (l/s)

## **Sanitary**

### Available Sanitary Sewer

- 250mm (CONC) – Sandcastle Dr
  - 450mm (CONC) – Baseline Rd (Graham Creek Trunk Collector Sewer)
1. There may be limited capacity in the downstream sewer system (West Nepean Trunk). Refer to the following holding provision. Maximum allowable sanitary flow from site will be confirmed by City staff. Please provide preliminary estimate of sanitary flow.
    - a. The sanitary flows from the subject site cannot exceed 14 litres/second until such time that the capacity study has been completed for the West Nepean trunk sewer, after which the allowed flows to be permitted for development for the site are to be in accordance with determinations made through the above noted study.
  2. Where service lateral connection is greater than 50% of the diameter of the main sewer, a maintenance hole will be required at the connection.
  3. Preference is to connect to local sewer on Sandcastle, not collector on Baseline Dr

## **Storm**

### Available Storm Sewer

- 300mm (CONC) – fronting 2946 Baseline
  - 450mm (CONC) and 300mm (CONC) – Sandcastle Dr
  - Both sewers ultimately outlet to Graham Creek
1. Roof drains to be connected downstream of any incorporated ICD within the SWM system.
  2. Where service lateral connection is greater than 50% of the diameter of the main sewer, a maintenance hole will be required at the connection.

### Stormwater Management

1. Quantity Control
  - a. Required for the site up to and including the 100-yr storm event.
  - b. Control to the 5-year storm event.
  - c. Time of Concentration (Tc): pre-development or maximum=10min.
  - d. Allowable runoff coefficient(c): Lesser of pre-development or c=0.5.
  - e. If underground/inline stormwater storage is proposed, an average release rate equal to 50% of the determined peak allowable rate must be used. Otherwise, disregard the underground/inline storage as available storage or provide modeling to support the proposed design. The reasoning for this restriction is that the discharge rate at full storage is not representative of the discharge rate for more frequent storm events. Halving the discharge rate compensates for the inaccuracies of the modified rational method when underground storage is used.

- f. Provide both pre and post development stormwater management plans, showing individual drainage areas and their respective coefficients.
  - g. If roof storage is proposed, please provide a roof drainage plan showing the 5 and 100-year storm ponding levels. Include the roof drain type, opening settings, and flow rate.
  - h. Per Technical Bulletin PIEDTB-2016-01 section 8.3.11.1 there shall be no surface ponding on private parking areas during the 2-year storm rainfall event.
  - i. Please note that the minimum orifice dia. for a plug style ICD is 83mm and the minimum flow rate from a vortex ICD is 6 L/s in order to reduce the likelihood of plugging.
2. Quality Control: Please consult with the Rideau Valley Conservation Authority (MVCA) regarding water quality control restrictions for the subject site. Include correspondence in report.
  3. Ministry of Environment, Conservation, and Parks (MECP): Designer to determine if approval for sewage works under Section 53 of OWRA is required and to determine the type of application required. Reviews will be done through Transfer of Review or Direct Submission. If SWM will be integrated with neighboring 2940 Baseline Development, ECA will be required due to drainage across multiple parcels.

#### **Phase I and Phase II ESA**

1. Phase I ESA is a requirement; Phase II ESA requirement will be dependent on the result of the Phase I ESA.
2. As per the Ministry of the Environment, Guide for Completing Phase One Environmental Site Assessments under Ontario Regulation 153/04, dated June 2011, the date the last work was done on the records review, interviews and site reconnaissance for a Phase I Environmental Site Assessment (ESA) can be no more than 18 months old or an update is required.
3. Phase I ESA must include Ecolog ERIS Report.
4. Phase I ESAs and Phase II ESAs must conform to clause 4.8.4 of the Official Plan that requires that development applications conform to Ontario Regulation 153/04.
5. Phase I/II ESA to comment on the need for a Record of Site Condition.

#### **Geotechnical Investigation**

1. Updated Geotechnical Report is required for this development proposal. The Geotechnical Investigation must apply to the entire development area and recommendations applied to the current proposal
2. Clay soils a concern for this site; to be discussed in report
3. The Geotechnical Report shall also speak to any proposed underground stormwater storage and provide confirmation that the site subsurface characteristics (groundwater table elevation, soil type) are appropriate. Of note, the high groundwater table must be 1.0m above the bottom of any proposed storage system per MECP requirements.
4. The Geotechnical Report shall also discuss potential groundwater lowering effects on neighbouring structures and infrastructure

#### **Exterior Lighting**

1. If exterior light fixtures are proposed, provide a plan showing the location of all exterior fixtures and include a table providing fixture details (make, model, mounting heights). All external light fixtures must meet the criteria for full cut-off classification as recognized by the Illuminating Engineering Society of North America (IESNA or IES), resulting in minimal light spillage onto adjacent properties (as a guideline, 0.5 fc is normally the maximum allowable spillage). Provide certification letter from a relevant Professional Engineer.

## **Other**

1. Retaining walls greater than 1.0m must be designed by a Professional Engineer. Plans to be submitted with the Application.

## **General Information**

1. The Servicing Study Guidelines for Development Applications are available at the following address: <https://ottawa.ca/en/city-hall/planning-and-development/information-developers/development-application-review-process/development-application-submission/guide-preparing-studies-and-plans#servicing-study-guidelines-development-applications>
2. Servicing and site works shall be in accordance with the following documents:
  - Ottawa Sewer Design Guidelines (October 2012) (including subsequent Technical Bulletins)
  - Ottawa Design Guidelines – Water Distribution (2010) (including subsequent Technical Bulletins)
  - Geotechnical Investigation and Reporting Guidelines for Development Applications in the City of Ottawa (2007)
  - Ottawa Standard Tender Documents (latest version)
3. Record drawings and utility plans are also available for purchase from the City (Contact the City's Information Centre by email at [InformationCentre@ottawa.ca](mailto:InformationCentre@ottawa.ca) or by phone at (613) 580-2424 x.44455).
4. Any proposed work in utility easements requires written consent of easement owner.
5. All submitted report and plan pdf documents to be flattened and unsecured to allow for editing and ease of use.
6. All documents prepared by Engineers shall be signed and dated on the seal.

## **Transportation:**

1. Follow Traffic Impact Assessment Guidelines and proceed to the scoping report as soon as possible.
  - Please proceed to Step 4
2. Noise Impact Studies required for the following:
  - Road (within 100m of a collector)
  - Stationary
3. On site plan:
  - Show all details of the roads abutting the site up to and including the opposite curb; include such items as pavement markings, accesses and/or sidewalks.
  - Turning templates will be required for all accesses showing the largest vehicle to access the site; required for internal movements and at all access (entering and exiting and going in both directions).
  - Show all curb radii measurements; ensure that all curb radii are reduced as much as possible.
  - Show lane/aisle widths.
4. As the site proposed is residential, AODA legislation applies for all areas accessible to the public (i.e. outdoor pathways, parking, etc.).

## **Forestry:**

TCR requirements:

1. a Tree Conservation Report (TCR) must be supplied for review along with the suite of other plans/reports required by the City
  - a. an approved TCR is a requirement of Site Plan approval.
2. As of January 1 2021, any removal of privately-owned trees 10cm or larger in diameter, or publicly (City) owned trees of any diameter requires a tree permit issued under the Tree Protection Bylaw (Bylaw 2020 – 340); the permit will be based on an approved TCR and made available at or near plan approval.
3. The Planning Forester from Planning and Growth Management as well as foresters from Forestry Services will review the submitted TCR
  - a. If tree removal is required, both municipal and privately-owned trees will be addressed in a single permit issued through the Planning Forester
  - b. Compensation may be required for city owned trees – if so, it will need to be paid prior to the release of the tree permit
4. the TCR must list all trees on site by species, diameter and health condition
5. please identify trees by ownership – private onsite, private on adjoining site, city owned, co-owned (trees on a property line)
6. the TCR must list all trees on adjacent sites if they have a critical root zone that extends onto the development site
7. If trees are to be removed, the TCR must clearly show where they are, and document the reason they cannot be retained
8. All retained trees must be shown and all retained trees within the area impacted by the development process must be protected as per City guidelines available at [Tree Protection Specification](#) or by searching Ottawa.ca
  - a. the location of tree protection fencing must be shown on a plan
  - b. show the critical root zone of the retained trees
  - c. if excavation will occur within the critical root zone, please show the limits of excavation
9. the City encourages the retention of healthy trees; if possible, please seek opportunities for retention of trees that will contribute to the design/function of the site.
10. For more information on the process or help with tree retention options, contact Mark Richardson [mark.richardson@ottawa.ca](mailto:mark.richardson@ottawa.ca) or on [City of Ottawa](#)

LP tree planting requirements:

For additional information on the following please contact [adam.palmer@Ottawa.ca](mailto:adam.palmer@Ottawa.ca)

#### Minimum Setbacks

- Maintain 1.5m from sidewalk or MUP/cycle track.
- Maintain 2.5m from curb
- Coniferous species require a minimum 4.5m setback from curb, sidewalk or MUP/cycle track/pathway.
- Maintain 7.5m between large growing trees, and 4m between small growing trees. Park or open space planting should consider 10m spacing.
- Adhere to Ottawa Hydro's planting guidelines (species and setbacks) when planting around overhead primary conductors.

#### Tree specifications

- Minimum stock size: 50mm tree caliper for deciduous, 200cm height for coniferous.

- Maximize the use of large deciduous species wherever possible to maximize future canopy coverage
- Tree planting on city property shall be in accordance with the City of Ottawa’s Tree Planting Specification; and include watering and warranty as described in the specification (can be provided by Forestry Services).
- Plant native trees whenever possible
- No root barriers, dead-man anchor systems, or planters are permitted.
- No tree stakes unless necessary (and only 1 on the prevailing winds side of the tree)

Hard surface planting

- Curb style planter is highly recommended
- No grates are to be used and if guards are required, City of Ottawa standard (which can be provided) shall be used.
- Trees are to be planted at grade

Soil Volume

- Please ensure adequate soil volumes are met:

Tree Type/Size	Single Tree Soil Volume (m3)	Multiple Tree Soil Volume (m3/tree)
Ornamental	15	9
Columnar	15	9
Small	20	12
Medium	25	15
Large	30	18
Conifer	25	15

Please note that these soil volumes are not applicable in cases with Sensitive Marine Clay.

Sensitive Marine Clay

- Please follow the City’s 2017 Tree Planting in Sensitive Marine Clay guidelines

Please refer to the links to [“Guide to preparing studies and plans”](#) and fees for general information. Additional information is available related to [building permits](#), [development charges](#), and the [Accessibility Design Standards](#). Be aware that other fees and permits may be required, outside of the development review process. You may obtain background drawings by contacting [informationcentre@ottawa.ca](mailto:informationcentre@ottawa.ca).

These pre-con comments are valid for one year. If you submit a development application(s) after this time, you may be required to meet for another pre-consultation meeting and/or the submission requirements may change. You are as well encouraged to contact us for a follow-up meeting if the plan/concept will be further refined.

Please contact me at [Lisa.Stern@ottawa.ca](mailto:Lisa.Stern@ottawa.ca) or at 613-580-2424 extension 21108 if you have any questions.

# Appendix G Drawings



Copyright Reserved

The Contractor shall verify and be responsible for all dimensions. DO NOT scale the drawing - any errors or omissions shall be reported to Stantec without delay.  
The Copyrights to all designs and drawings are the property of Stantec. Reproduction or use for any purpose other than that authorized by Stantec is forbidden.

Legend

Notes

0	ISSUED FOR SPA	MJS	RB	23.05.25	
Revision		By	Appd.	YY.MM.DD	
File Name:	160401676 D8.dwg	MJS	RB	MJS	23.03.31
		Dwn.	Chkd.	Dgn.	YY.MM.DD

Permit-Seal



Client/Project

BRIGIL HOMES

BASELINE TOWERS 4-5-6  
2946 BASELINE ROAD  
OTTAWA, ON, CANADA

Title

NOTES AND LEGENDS PLAN

Project No.	Scale	0 5 15 25m
160401676	1:500	
Drawing No.	Sheet	Revision

NL-1

1 of 7

0

GENERAL NOTES AND SPECIFICATIONS

- ALL MATERIALS AND CONSTRUCTION METHODS TO BE IN ACCORDANCE WITH OPS AND CITY OF OTTAWA STANDARD SPECIFICATIONS AND DRAWINGS AND OPSD SUPPLEMENT, ONTARIO PROVINCIAL STANDARDS WILL APPLY WHERE NO CITY STANDARDS ARE AVAILABLE.
- THE CONTRACTOR IS RESPONSIBLE FOR OBTAINING ALL PERMITS REQUIRED AND BEAR COST OF SAME INCLUDING WATER PERMIT AND ASSOCIATED COSTS.
- SERVICE AND UTILITY LOCATIONS ARE APPROXIMATE. CONTRACTOR TO VERIFY LOCATION AND ELEVATION OF EXISTING SERVICES AND UTILITIES PRIOR TO CONSTRUCTION. CONTRACTOR SHALL BE RESPONSIBLE FOR OBTAINING LOCATES FROM ALL UTILITY COMPANIES TO LOCATE EXISTING UTILITIES PRIOR TO EXCAVATION. THE CONTRACTOR IS RESPONSIBLE FOR PROTECTION AND REINSTATEMENT.
- ALL DISTURBED AREAS SHALL BE REINSTATED TO EQUAL OR BETTER CONDITION TO THE SATISFACTION OF THE ENGINEER & THE CITY. PAVEMENT REINSTATEMENT FOR SERVICE AND UTILITY CUTS SHALL BE IN ACCORDANCE WITH OPSD 509.010 AND OPSS 310.
- ALL WORK SHALL BE COMPLETED IN ACCORDANCE WITH THE "OCCUPATIONAL HEALTH AND SAFETY ACT AND REGULATION FOR CONSTRUCTION PROJECTS". THE GENERAL CONTRACTOR SHALL BE DEEMED TO BE THE CONSTRUCTOR AS DEFINED IN THE ACT.
- THE CONTRACTOR SHALL SUBMIT AN EROSION AND SEDIMENTATION CONTROL PLAN THAT WILL IMPLEMENT BEST MANAGEMENT PRACTICES TO PROVIDE PROTECTION FOR RECEIVING STORM SEWERS OR DRAINAGE DURING CONSTRUCTION ACTIVITIES. THIS PLAN SHALL INCLUDE BUT NOT BE LIMITED TO CATCH BASINS INSERTS, STRAW BALE CHECK DAMS AND SEDIMENT CONTROLS AROUND ALL DISTURBED AREAS. DEWATERING SHALL BE PUMPED INTO SEDIMENT TRAPS.
- SITE PLAN PREPARED BY NEUF ARCHITECTS, DATED 2022-01-01, DRAWING A100, PROJECT NAME: 2946 BASELINE ROAD, PROJECT No. 12762.
- TOPOGRAPHIC SURVEY SUPPLIED BY ANNIS, O'SULLIVAN, VOLLEBEKK LTD, PROJECT No. 23653-23, TOPOGRAPHIC PLAN OF SURVEY PART OF LOT 35, CONCESSION 3 (RIDEAU FRONT) AND PART OF THE ROAD ALLOWANCE BETWEEN CONCESSION 2 (OTTAWA FRONT) AND CONCESSION 3 (RIDEAU FRONT), (CLOSED BY BY-LAW 51-64, INST. CR521552 GEORGIAN TOWNSHIP OF NEPEAN, CITY OF OTTAWA.
- REFER TO LANDSCAPE ARCHITECTURE PLAN FOR ALL LANDSCAPING FEATURES (e. TREES, WALKWAYS, PARK DETAILS, NOISE BARRIERS, FENCES etc.)
- GEOTECHNICAL INVESTIGATION PROPOSED MULTI-STORY BUILDING - TOWER 4 TO 6, 2946 BASELINE ROAD, OTTAWA, ON, PREPARED BY PATERSON GROUP, DATED MAY 8, 2023, REPORT No. PG6107-1. GEOTECHNICAL INFORMATION PRESENTED ON THESE DRAWINGS MAY BE INTERPOLATED FROM THE ORIGINAL REPORT. REFER TO ORIGINAL GEOTECHNICAL REPORT FOR ADDITIONAL DETAILS AND TO VERIFY ASSUMPTIONS MADE HEREIN.
- STREET LIGHTING TO CITY OF OTTAWA STANDARDS.
- ALL DIMENSIONS ARE IN METRES UNLESS OTHERWISE STATED. DIMENSIONS SHALL BE CHECKED AND VERIFIED IN THE FIELD BY THE CONTRACTOR PRIOR TO THE START OF CONSTRUCTION. ANY DISCREPANCIES TO BE REPORTED IMMEDIATELY TO ENGINEER.
- THERE WILL BE NO SUBSTITUTION OF MATERIALS UNLESS PRIOR WRITTEN APPROVAL BY THE CONTRACT ADMINISTRATOR AND DIRECTOR OF ENGINEERING HAS BEEN OBTAINED.
- HERITAGE OPERATIONS UNIT OF THE ONTARIO MINISTRY OF CULTURE TO BE NOTIFIED IF DEEPLY BURIED ARCHEOLOGICAL REMAINS ARE FOUND ON THE PROPERTY DURING CONSTRUCTION ACTIVITIES.

ROADWORKS

- ALL TOPSOIL AND ORGANIC MATERIAL TO BE STRIPPED FROM WITHIN THE FULL RIGHT OF WAY PRIOR TO CONSTRUCTION.
- SUB-EXCAVATE SOFT AREAS & FILL WITH GRANULAR 'B' COMPACTED IN 0.30m LAYERS.
- ALL GRANULAR FOR ROADS SHALL BE COMPACTED TO A MINIMUM OF 98% STANDARD PROCTOR MAXIMUM DRY DENSITY (SPMDD).
- ROAD SUBDRAINS SHALL BE CONSTRUCTED AS PER CITY OF OTTAWA STANDARD R1.
- ASPHALT WEAR COURSE SHALL NOT BE PLACED UNTIL THE VIDEO INSPECTION OF SEWERS & NECESSARY REPAIRS HAVE BEEN CARRIED OUT TO THE SATISFACTION OF THE CONSULTANT.
- CONTRACTOR TO OBTAIN A ROAD OCCUPANCY PERMIT 48 HOURS PRIOR TO COMMENCING ANY WORK WITHIN THE MUNICIPAL ROAD ALLOWANCE IF REQUIRED BY THE MUNICIPALITY. ALL WORK ON THE MUNICIPAL RIGHT OF WAY AND EASEMENTS TO BE INSPECTED BY THE MUNICIPALITY PRIOR TO BACKFILLING.
- PAVEMENT REINSTATEMENT FOR SERVICE AND UTILITY CUTS SHALL BE IN ACCORDANCE WITH CITY OF OTTAWA STANDARD R10, AND OPSD 509.010, AND OPSS 310.
- CONCRETE CURBS SHALL BE CONSTRUCTED AS PER CITY STANDARD SC1.1 AND SC1.3 (BARRIER OR MOUNTABLE CURB AS SHOWN ON DRAWINGS).
- CONCRETE SIDEWALKS SHALL BE CONSTRUCTED AS PER CITY STANDARDS SC3 AND SC1.4.
- PAVEMENT CONSTRUCTION AS PER GEOTECHNICAL INVESTIGATION PROPOSED MULTI-STORY BUILDING - TOWER 4 TO 6, 2946 BASELINE ROAD, OTTAWA, ON, PREPARED BY PATERSON GROUP, DATED MAY 8, 2023, PROJECT No. PG6107-1  
PAVEMENT STRUCTURE - CAR PARKING AREAS  
50mm SUPERPAVE 12.5 ASPHALTIC CONCRETE  
150 OPS GRANULAR 'A' BASE  
300 OPS GRANULAR 'B' TYPE II  
PAVEMENT STRUCTURE - ACCESS LANES AND HEAVY TRUCK  
40mm SUPERPAVE 12.5 ASPHALTIC CONCRETE  
50mm SUPERPAVE 19.0 ASPHALTIC CONCRETE  
150 OPS GRANULAR 'A' BASE  
450 OPS GRANULAR 'B' TYPE II

WATER SUPPLY SERVICING

- THE CONTRACTOR SHALL CONSTRUCT WATERMAIN, WATER SERVICES, CONNECTIONS & APPURTENANCES AS PER CITY OF OTTAWA SPECIFICATIONS & SHALL CO-ORDINATE AND PAY ALL RELATED COSTS INCLUDING THE COST OF CONNECTION, INSPECTION & DISINFECTION BY CITY PERSONNEL.

- WATERMAIN PIPE MATERIAL SHALL BE PVC CL 150 DR18. DEFLECTION OF WATERMAIN PIPE IS NOT TO EXCEED 1/2 OF THAT SPECIFIED BY THE MANUFACTURER. PVC WATERMAINS TO BE INSTALLED WITH TRACER WIRE IN ACCORDANCE WITH CITY OF OTTAWA STANDARD W36.
- WATER SERVICES ARE TO BE TYPE K SOFT COPPER AS PER CITY OF OTTAWA STANDARD W26 (UNLESS OTHERWISE NOTED).
- FIRE HYDRANTS TO BE INSTALLED AS PER CITY OF OTTAWA STANDARDS W18 AND W19.
- WATER VALVES TO BE INSTALLED AS PER CITY OF OTTAWA STANDARD W24.
- WATERMAIN TRENCH SHALL BE IN ACCORDANCE WITH CITY OF OTTAWA STD. W17 UNLESS OTHERWISE SPECIFIED. BEDDING AND COVER MATERIAL AS PER SECTION 6.4 OF THE GEOTECH REPORT.
- SERVICE CONNECTIONS SHALL BE INSTALLED A MINIMUM OF 2400mm FROM ANY CATCHBASIN, MANHOLE, OR OBJECT THAT MAY CONTRIBUTE TO FREEZING. THERMAL INSULATION SHALL BE INSTALLED ON ALL PROPOSED CBS ON THE W/M STREET SIDE WHERE 2400mm SEPARATION CANNOT BE ACHIEVED. (AS PER CITY OF OTTAWA W22 & W23)
- CATHODIC PROTECTION TO BE SUPPLIED ON METALLIC FITTINGS AS PER CITY OF OTTAWA W40 AND W42.
- THRUST BLOCKS TO BE INSTALLED AS PER CITY OF OTTAWA STANDARDS W25.3 AND W25.4.
- WATERMAIN TO HAVE MIN. 2.4m COVER, WHERE WATERMAIN COVER IS LESS THAN 2.4m, INSULATION TO BE SUPPLIED IN ACCORDANCE WITH CITY STANDARD W22.
- WATERMAIN CROSSINGS ABOVE AND BELOW SEWERS TO BE INSTALLED AS PER CITY OF OTTAWA STANDARD W25 AND W25.2.
- PRESSURE REDUCING VALVES (PRV'S) IF REQUIRED, TO BE INSTALLED AS PER ONTARIO PLUMBING CODE.

STORM AND SANITARY SEWERS

- SANITARY SEWERS 375mm DIA. OR SMALLER SHALL BE PVC DR35. SANITARY SEWERS LARGER THAN 375mm SHALL BE CONCRETE CSA A 257.2 CLASS 100D AS PER OPSD 807.010.
- STORM SEWERS 375mm DIA. OR SMALLER SHALL BE PVC DR35. STORM SEWERS LARGER THAN 375mm SHALL BE CONCRETE CSA A 257.2 CLASS 100D AS PER OPSD 807.010
- ALL STORM AND SANITARY SEWER BEDDING SHALL BE INSTALLED AS PER SECTION 6.4 OF THE GEOTECH REPORT.
- STORM AND SANITARY MANHOLES SHALL BE 1200mm DIAMETER IN ACCORDANCE WITH OPSD-701.01 (UNLESS OTHERWISE NOTED) c/w FRAME AND COVER AS PER CITY OF OTTAWA S24, S24.1, AND S25 WHERE APPLICABLE. CATCH BASIN MANHOLE FRAME AND COVERS PER S25 AND S28.1. ALL STORM MANHOLES WITH SEWERS 900mm DIA SEWERS AND OVER IN SIZE SHALL BE BENCHED. ALL OTHER STORM MANHOLES SHALL BE COMPLETED WITH 300mm SUMPS AS PER CITY STANDARDS. SANITARY MANHOLES SHALL NOT HAVE SUMPS.
- ALL SEWERS CONSTRUCTED WITH GRADES 0.50% OR LESS, TO BE INSTALLED WITH LASER AND CHECKED WITH LEVEL INSTRUMENT PRIOR TO BACKFILLING.
- FOR STORM SEWER INSTALLATION (EXCLUDING CB LEADS) THE MINIMUM DEPTH OF COVER OVER THE CROWN OF THE SEWER IS 2.0m. FOR SANITARY SEWERS THE MINIMUM DEPTH OF COVER IS 2.5m OVER PIPE OVERT.
- ALL STORM AND SANITARY SERVICES TO BE EQUIPPED WITH APPROVED BACKWATER VALVES.
- STORM AND SANITARY SERVICE LATERALS TO BE SDR 28 INSTALLED AT MIN. 1.0% SLOPE.
- CATCH BASINS SHALL BE INSTALLED IN ACCORDANCE WITH CITY STANDARDS S1, S2, S3 c/w FRAME AND GRATE AS PER S19, CURB INLET FRAME AND GRATE PER S22 AND S23. CATCH BASIN MANHOLES FRAME AND GRATE AS PER S25 FRAME AND S28.1 COVER. PROVIDE 150mm ADJUSTED SPACERS. ALL CATCH BASINS SHALL HAVE SUMPS (600mm DEEP). STREET CATCH BASIN LEADS SHALL BE 200mm DIA. (MIN) PVC DR 35 AT 1.0% GRADE WHERE NOT OTHERWISE SHOWN ON PLAN. CATCH BASINS WILL BE INSTALLED WITH INLET CONTROL DEVICES (ICD) AS PER ICD SCHEDULE ON STORM DRAINAGE PLAN.
- CLAY SEALS TO BE INSTALLED AS PER CITY STANDARD DRAWING S8. THE SEALS SHOULD BE AT LEAST 1.5m LONG (IN THE TRENCH DIRECTION) AND SHOULD EXTEND FROM TRENCH WALL TO TRENCH WALL. GENERALLY, THE SEALS SHOULD EXTEND FROM THE FROST LINE AND FULLY PENETRATE THE BEDDING, SUBBEDDING AND COVER MATERIAL. THE BARRIERS SHOULD CONSIST OF RELATIVELY DRY AND COMPACTABLE BROWN SILTY CLAY PLACED IN MAXIMUM 225mm THICK LOOSE LAYERS COMPACTED TO A MINIMUM OF 95% OF THE MATERIAL'S SPMDD. THE CLAY SEALS SHOULD BE PLACED AT THE SITE BOUNDARIES AND AT STRATEGIC LOCATIONS AT NO MORE THAN 60m INTERVALS IN THE SERVICE TRENCHES. FOR DETAILS REFER TO GEOTECHNICAL INVESTIGATION.
- GRANULAR 'A' SHALL BE PLACED TO A MINIMUM THICKNESS OF 300 mm AROUND ALL STRUCTURES WITHIN PAVEMENT AREA AND COMPACTED TO A MINIMUM OF 98% STANDARD PROCTOR DENSITY.
- CONTRACTOR SHALL PERFORM LEAKAGE TESTING, IN THE PRESENCE OF THE CONSULTANT, FOR SANITARY SEWERS IN ACCORDANCE WITH OPS 410 AND OPS 407. CONTRACTOR SHALL PERFORM VIDEO INSPECTION OF ALL STORM AND SANITARY SEWERS. A COPY OF THE VIDEO AND INSPECTION REPORT SHALL BE SUBMITTED TO THE CONSULTANT FOR REVIEW.
- ANY SEWER ABANDONMENT TO BE CONDUCTED ACCORDING TO CITY OF OTTAWA STANDARD S11.4
- SEWERS WITH LESS THAN 1.5m COVER TO BE INSULATED IN ACCORDANCE WITH CITY STANDARD W22.

GRADING

- ALL GRANULAR BASE & SUB BASE COURSE MATERIALS SHALL BE COMPACTED TO 98% STANDARD PROCTOR MAX. DRY DENSITY.
- SUB-EXCAVATE SOFT AREAS & FILL WITH GRANULAR 'B' COMPACTED IN 0.15m LAYERS.
- ALL DISTURBED GRASSED AREAS SHALL BE RESTORED TO ORIGINAL CONDITION OR BETTER, WITH SOD ON MIN. 100mm TOPSOIL. THE RELOCATION OF TREES AND SHRUBS SHALL BE SUBJECT TO APPROVAL BY THE PROJECT LANDSCAPE ARCHITECT OR ENGINEER.
- 100 YEAR PONDING DEPTH TO BE 0.30m (MAXIMUM).
- EMBANKMENTS TO BE SLOPED AT MIN. 3:1, UNLESS OTHERWISE SPECIFIED.
- ALL SWALES TO BE MIN. 0.15m DEEP WITH MIN. 3:1 SIDE SLOPES UNLESS OTHERWISE NOTED. THE MINIMUM LONGITUDINAL SLOPE

TO BE 1.5% OR 1.0% WHEN PERFORATED SUBDRAIN IS INSTALLED.

- ALL RETAINING WALLS GREATER THAN 1.0m IN HEIGHT ARE TO BE DESIGNED, APPROVED, AND STAMPED BY STRUCTURAL ENGINEER.
- FENCES OR RAILINGS ARE REQUIRED FOR RETAINING WALLS GREATER THAN 0.60m IN HEIGHT.
- EXCESS EXCAVATED MATERIAL SHALL BE REMOVED FROM THE SITE.
- ALL NECESSARY CLEARING AND GRUBBING SHALL BE COMPLETED BY THE CONTRACTOR, REVIEW WITH CONTRACT ADMINISTRATOR AND THE CITY OF OTTAWA PRIOR TO TREE CUTTING.
- REFER TO DRAWING EC DS-1 FOR EROSION AND SEDIMENT CONTROL DETAILS.

Best Management Practices

CONTRACTOR TO PROVIDE EROSION AND SEDIMENT CONTROLS (BEST MANAGEMENT PRACTICES) DURING CONSTRUCTION OF THIS PROJECT.

EROSION MUST BE MINIMIZED AND SEDIMENTS MUST BE REMOVED FROM CONSTRUCTION SITE RUN-OFF IN ORDER TO PROTECT DOWNSTREAM AREAS. DURING ALL CONSTRUCTION, EROSION AND SEDIMENTATION SHOULD BE CONTROLLED BY THE FOLLOWING TECHNIQUES:

- LIMIT THE EXTENT OF EXPOSED SOILS AT ANY GIVEN TIME.
- REVEGETATE EXPOSED AREAS AND SLOPES AS SOON AS POSSIBLE.
- MINIMIZE AREA TO BE CLEARED AND GRUBBED.
- PROTECT EXPOSED SLOPES WITH PLASTIC OR SYNTHETIC MULCHES.
- INSTALL CATCH BASIN INSERTS OR EQUIVALENT IN ALL PROPOSED CATCH BASINS AND CATCH BASIN MANHOLES AND IN ALL EXISTING CATCH BASINS THAT WILL RECEIVE RUN-OFF FROM THE SITE.
- A SILT FENCE SHALL BE INSTALLED AROUND THE PERIMETER OF ALL AND ANY STOCKPILES OF MATERIAL TO BE USED OR REMOVED FROM SITE. (LOCATION TO BE DETERMINED)
- A VISUAL INSPECTION SHALL BE DONE DAILY ON SEDIMENT CONTROL MEASURES AND CLEANED OF ANY ACCUMULATED SILT AS REQUIRED. THE DEPOSITS WILL BE DISPOSED OFF SITE AS PER THE REQUIREMENTS OF THE CONTRACT.
- SEDIMENT CONTROL BARRIERS MAY ONLY BE REMOVED TEMPORARILY WITH APPROVAL OF CONTRACT ADMINISTRATOR TO ACCOMMODATE CONSTRUCTION OPERATIONS. ALL AFFECTED BARRIERS MUST BE REINSTATED AT NIGHT WHEN CONSTRUCTION IS COMPLETED. NO REMOVAL WILL OCCUR IF THERE IS A SIGNIFICANT RAINFALL EVENT ANTICIPATED (>10mm) UNLESS A NEW DEVICE HAS BEEN INSTALLED TO PROTECT EXISTING STORM AND SANITARY SEWER SYSTEMS, OR DOWNSTREAM WATERCOURSES.
- NO REFUELING OR CLEANING OF EQUIPMENT IS PERMITTED NEAR ANY EXISTING WATERWAY.
- CONTRACTOR SHALL REMOVE SEDIMENT CONTROL MEASURES WHEN, IN THE OPINION OF THE CONTRACT ADMINISTRATOR, THE MEASURES IS NO LONGER REQUIRED. NO CONTROL MEASURES SHALL BE PERMANENTLY REMOVED WITHOUT PRIOR WRITTEN AUTHORIZATION FROM THE CONTRACT ADMINISTRATOR.
- THE CONTRACTOR SHALL PERIODICALLY, OR WHEN REQUESTED BY THE CONTRACT ADMINISTRATOR, CLEAN OUT ACCUMULATED SEDIMENTS AS REQUIRED.
- THE CONTRACTOR SHALL IMMEDIATELY REPORT TO THE ENGINEER ANY ACCIDENTAL DISCHARGES OF SEDIMENT MATERIAL INTO THE WATERCOURSE. APPROPRIATE RESPONSE MEASURES, INCLUDING ANY REPAIRS TO EXISTING CONTROL MEASURES OR THE IMPLEMENTATION OF ADDITIONAL CONTROL MEASURES, SHALL BE CARRIED OUT BY THE CONTRACTOR WITHOUT DELAY.
- CONTRACTOR SHALL INSTALL MUD MAT AT CONSTRUCTION ENTRANCE TO THE SITE.

LEGEND

EXISTING CONDITIONS

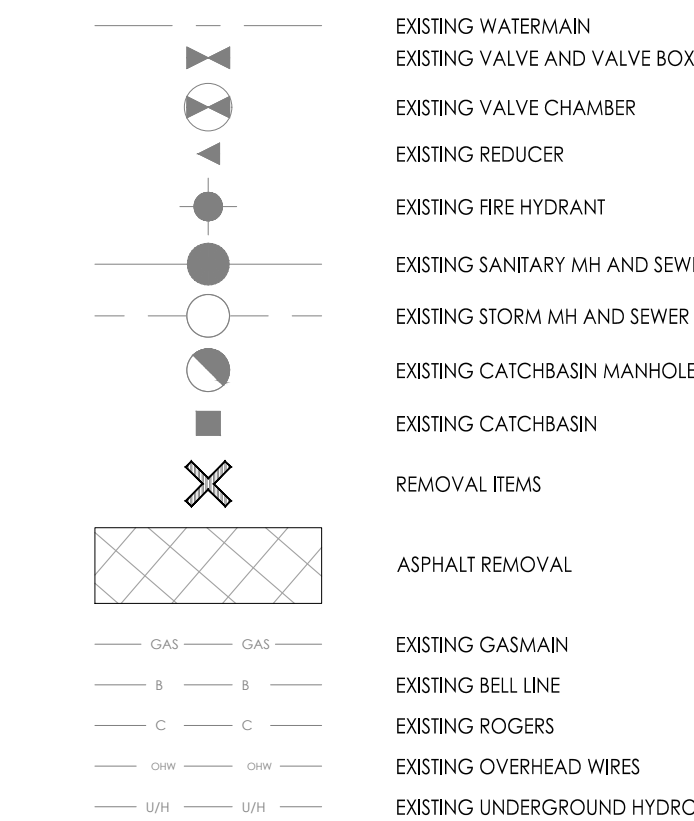

SERVICES

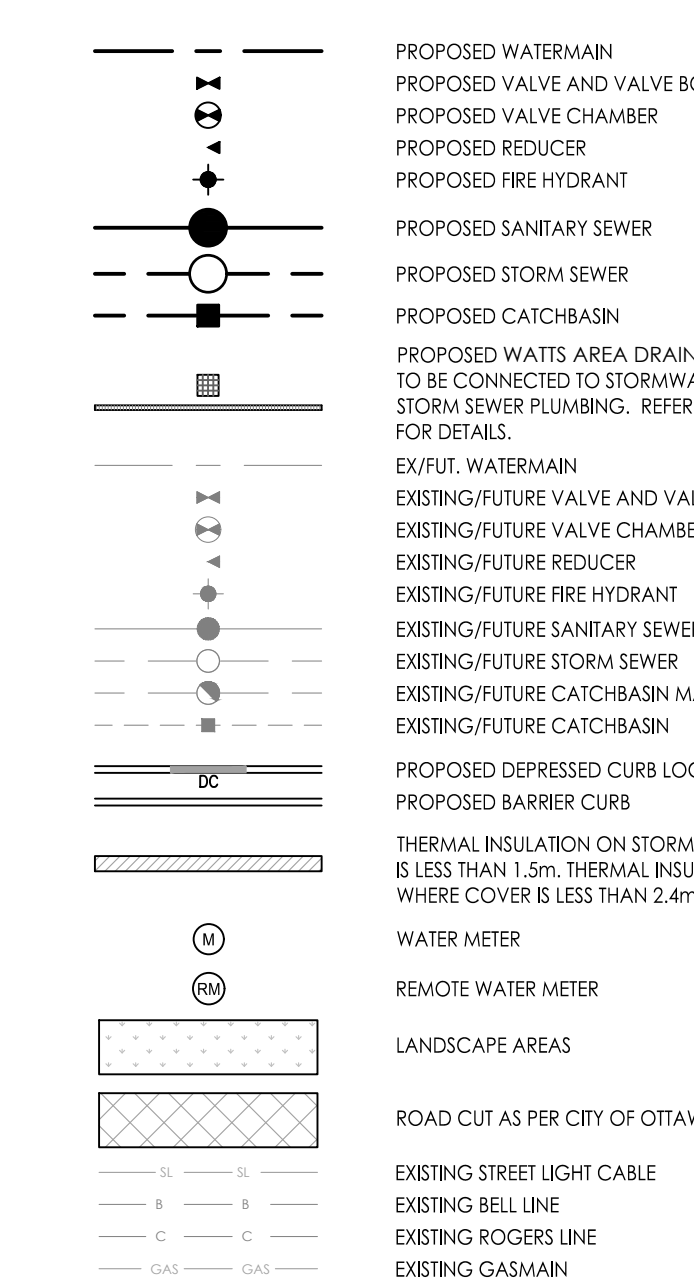

SANITARY DRAINAGE

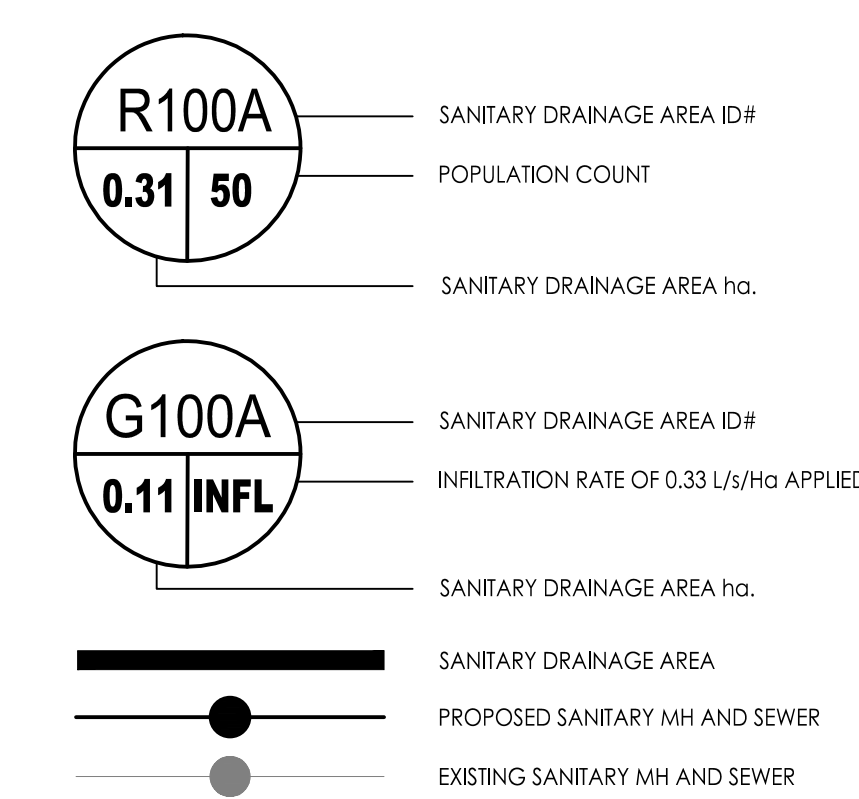

EROSION CONTROL

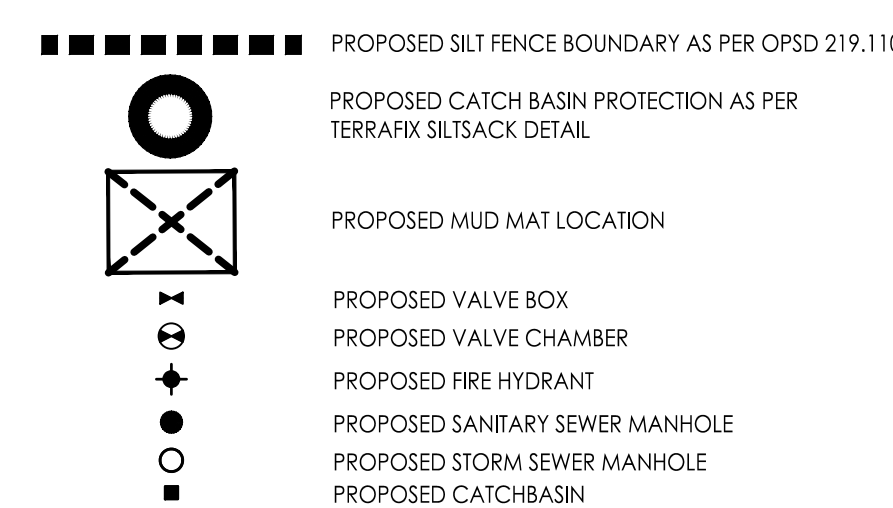

GRADING

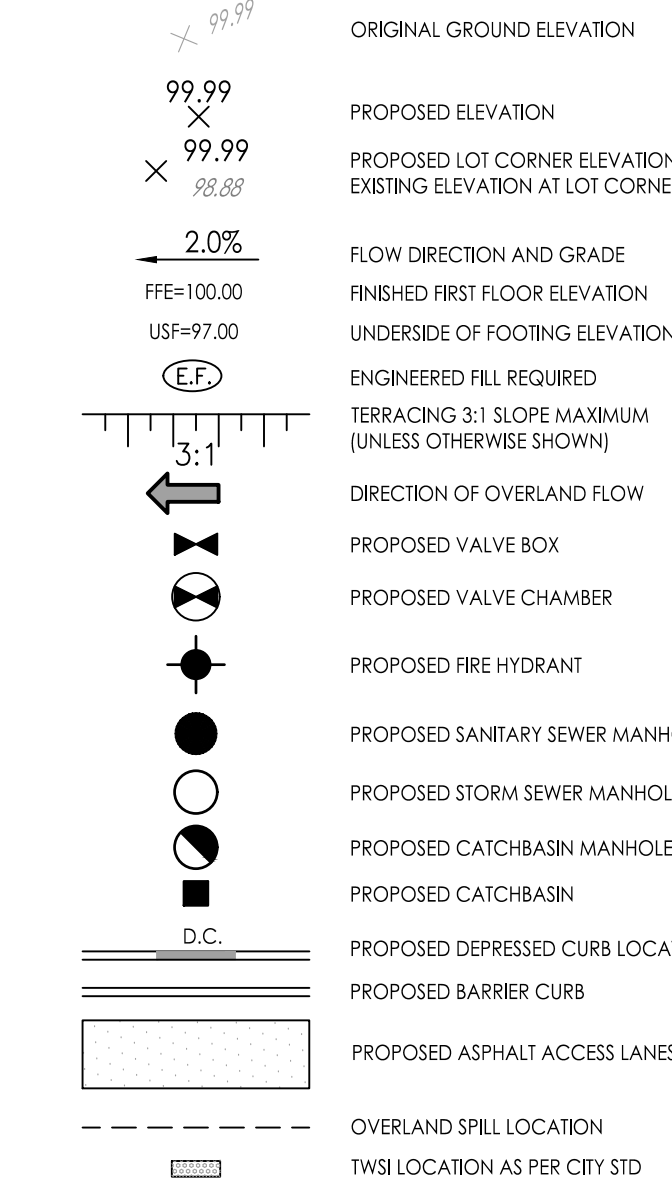

STORM DRAINAGE

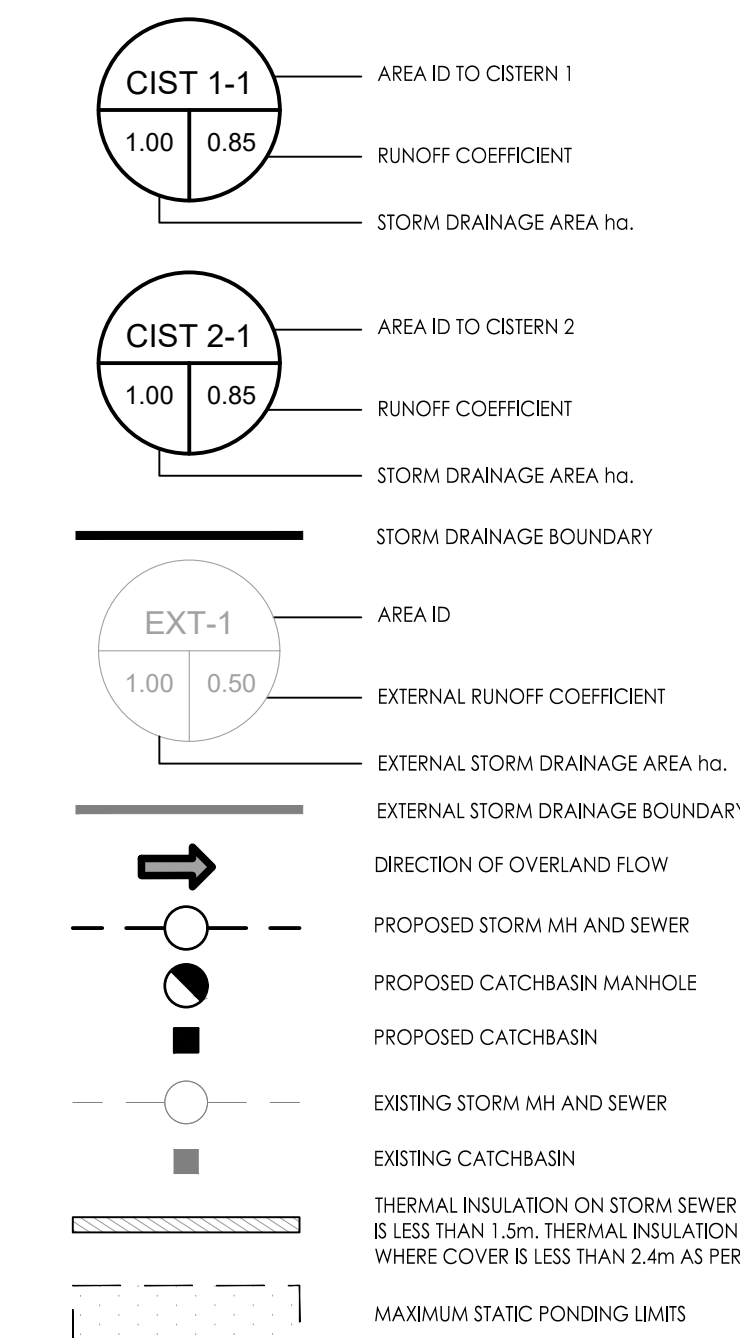



### Copyright Reserved

The Contractor shall verify and be responsible for all dimensions. DO NOT scale the drawing - any errors or omissions shall be reported to Stantec without delay.  
The Copyrights to all designs and drawings are the property of Stantec. Reproduction or use for any purpose other than that authorized by Stantec is forbidden.

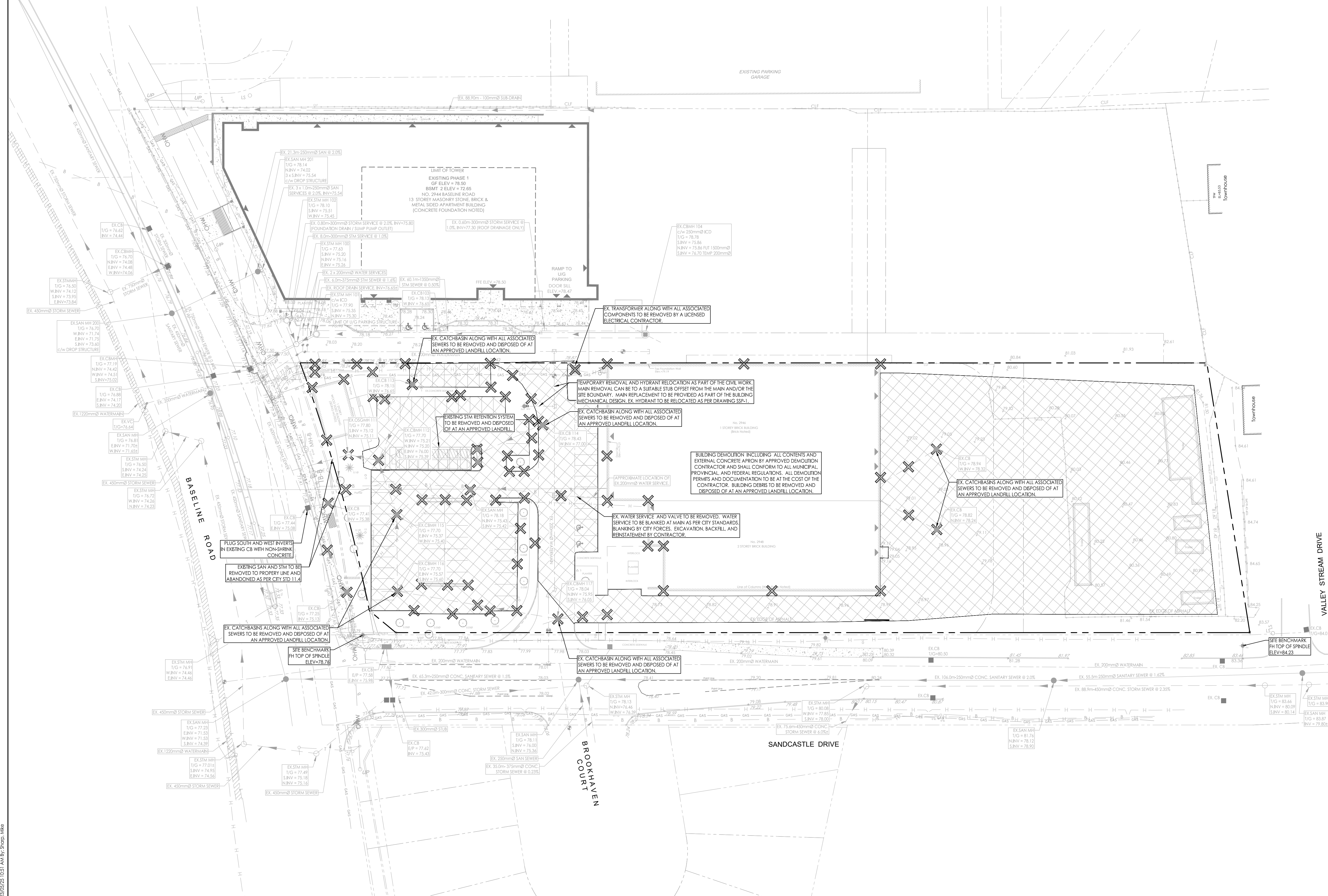
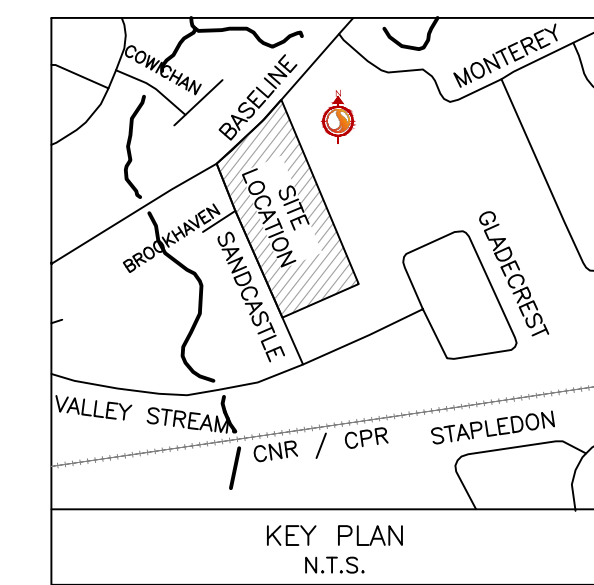

### Legend

- EXISTING WATERMAIN
- EXISTING VALVE AND VALVE BOX
- EXISTING VALVE CHAMBER
- EXISTING REDUCER
- EXISTING FIRE HYDRANT
- EXISTING SANITARY MH AND SEWER
- EXISTING STORM MH AND SEWER
- EXISTING CATCHBASIN MANHOLE
- EXISTING CATCHBASIN
- REMOVAL ITEMS
- ASPHALT REMOVAL
- EXISTING GASMAIN
- EXISTING BELL LINE
- EXISTING ROGERS
- EXISTING OVERHEAD WIRES
- EXISTING UNDERGROUND HYDRO

### Notes

- THE LOCATION OF UTILITIES IS APPROXIMATE ONLY AND THE EXACT LOCATION SHOULD BE DETERMINED BY CONSULTING THE MUNICIPAL AUTHORITIES AND UTILITY COMPANIES CONCERNED. THE CONTRACTOR SHALL PROTECT THE LOCATION OF UTILITIES AND SHALL BE RESPONSIBLE FOR THEIR PROTECTION AND THE IMPLEMENTATION OF ANY NECESSARY PROCEDURES CALLED FOR IN THE APPROPRIATE STANDARD REGULATIONS.
- FOR TREE REMOVALS, REFER TO TREE CONSERVATION REPORT PREPARED BY SITE FORM.
- APPROXIMATE ASPHALT REMOVAL = 6550m<sup>2</sup>

Revision	By	App'd.	YY.MM.DD
0	MJS	RB	23.05.25
1	MJS	RB	23.03.31

Permit-Seal



Client/Project  
**BRIGIL HOMES**

BASELINE TOWERS 4-5-6  
2946 BASELINE ROAD  
OTTAWA, ON, CANADA

Title  
**EXISTING CONDITIONS AND REMOVALS PLAN**

Project No. 160401676	Scale 1:400	Sheet 7 of 7	Revision 0
--------------------------	----------------	-----------------	---------------

EX/RM-1 2 of 7 0

V:\160401676\160401676.dwg  
2023/05/25 10:51 AM  
ORIGINAL SHEET - ARCH D



Copyright Reserved

The Contractor shall verify and be responsible for all dimensions. DO NOT scale the drawing - any errors or omissions shall be reported to Stantec without delay.  
The Copyrights to all designs and drawings are the property of Stantec. Reproduction or use for any purpose other than that authorized by Stantec is forbidden.

Legend

- PROPOSED WATERMAIN
- PROPOSED VALVE AND VALVE BOX
- PROPOSED VALVE CHAMBER
- PROPOSED REDUCER
- PROPOSED FIRE HYDRANT
- PROPOSED SANITARY SEWER
- PROPOSED STORM SEWER
- PROPOSED CATCHBASIN
- EXISTING/FUTURE VALVE AND VALVE BOX  
EXISTING/FUTURE VALVE CHAMBER  
EXISTING/FUTURE REDUCER  
EXISTING/FUTURE FIRE HYDRANT  
EXISTING/FUTURE SANITARY SEWER  
EXISTING/FUTURE STORM SEWER  
EXISTING/FUTURE CATCHBASIN MANHOLE  
EXISTING/FUTURE CATCHBASIN
- PROPOSED DEPRESSED CURB LOCATIONS
- PROPOSED BARRIER CURB
- THERMAL INSULATION ON STORM SEWER WHERE COVER IS LESS THAN 1.5m. THERMAL INSULATION ON WATERMAIN WHERE COVER IS LESS THAN 2.4m AS PER W22.
- WATER METER
- REMOTE WATER METER
- LANDSCAPE AREAS
- ROAD CUT AS PER CITY STANDARD DETAIL R10
- EXISTING STREET LIGHT CABLE
- EXISTING BELL LINE
- EXISTING ROGESS LINE
- EXISTING GASMAIN

Notes

- ALL CATCH BASINS AND TRENCH DRAINS TO BE CONNECTED TO INTERNAL PLUMBING AND COLLECTED IN STORM WATER MANAGEMENT SYSTEM. INSTALLATION BY OTHERS.
- FINAL METER AND REMOTE METER LOCATIONS TO BE CONFIRMED BY MECHANICAL CONSULTANT.
- THE LOCATION OF UTILITIES IS APPROXIMATE ONLY AND THE EXACT LOCATION SHOULD BE DETERMINED BY CONSULTING THE MUNICIPAL AUTHORITIES AND UTILITY COMPANIES CONCERNED. THE CONTRACTOR SHALL PROVE THE LOCATION OF UTILITIES AND SHALL BE RESPONSIBLE FOR THEIR PROTECTION AND THE IMPLEMENTATION OF ANY NECESSARY PROCEDURES CALLED FOR IN THE APPROPRIATE STANDARD AND REGULATIONS.
- INTERNAL PLUMBING AND SUMP PUMPS TO BE DESIGNED BY THE MECHANICAL CONSULTANT.
- STORMWATER MANAGEMENT TO BE PROVIDED THROUGH 2 CISTERNS LOCATED IN THE UNDERGROUND PARKING AREA. 1 CISTERN FOR PHASE 4 AND 1 CISTERN FOR PHASE 5/6.  
PHASE 4 74m<sup>3</sup> CISTERN. MAX RELEASE RATE TO STORM SEWER = 38.2 L/s.  
PHASE 5 25m<sup>3</sup> CISTERN. MAX RELEASE RATE TO STORM SEWER = 29.8 L/s.
- BOOSTER PUMPS TO BE PROVIDED TO MAINTAIN MINIMUM PRESSURES FOR TOWERS 6-STORIES AND HIGHER.
- SUMP PUMP REQUIRED TO DISCHARGE TO INTERNAL SANITARY SEWER. (REFER TO MECHANICAL DRAWINGS FOR DETAILS)
- FLOOR DRAINS LOCATED INSIDE PARKING GARAGE TO BE CONNECTED TO BUILDING INTERNAL SANITARY SEWER.
- USF TO BE CONFIRMED BY THE STRUCTURAL CONSULTANT.

Revision	By	Appd.	YY.MM.DD
0 ISSUED FOR SPA	MJS	RB	23.05.25

File Name: 160401676 D8.dwg

Permit Seal	Dwn.	Chkd.	Dgn.	YY.MM.DD
	MJS	RB	MJS	23.03.31

Client/Project  
**BRIGIL HOMES**  
2946 BASELINE ROAD  
OTTAWA, ON, CANADA

Title  
**SITE SERVICING PLAN**

Project No.  
160401676

Scale  
1:400

Drawing No. Sheet Revision

SSP-1 3 of 7 0

ICD TABLE				
CATCHBASIN ID	TRIBUTARY AREA ID	ICD TYPE	SYR FLOW (L/S)	100YR FLOW (L/S)
STM 200	CIST 2-1 TO 2-9	BUILDING MECHANICAL	29.8	29.8
	UNC-3	UNCONTROLLED	16.1	34.5
	UNC-4	UNCONTROLLED	7.1	14.0
	UNC-5	UNCONTROLLED	14.6	29.5
STM 101	CIST 1-1 TO 1-7, EXT-1	BUILDING MECHANICAL	38.2	38.2
	UNC-1	UNCONTROLLED	0.9	1.9
	UNC-2	UNCONTROLLED	3.9	7.4
	UNC-6	UNCONTROLLED	2.0	4.4

\*NOTE: FLOW CONTROL TO BE AS PER BUILDING MECHANICAL ENGINEERING DESIGN.  
ALL ROOF DRAINAGE CONSIDERED TO CONTRIBUTE DIRECTLY TO THE BUILDING CISTERN.

SEWER AND WATERMAIN CROSSING TABLE						
CROSSING	STM INV	STM OBV	SAN INV	SAN OBV	WTR TOP	WTR BTM
	79.91	80.21	79.41(79.34)±	79.66(79.73)±	80.92±	80.72±
	76.52	76.82	76.03(75.94)±	76.28(76.35)±	76.04±	75.84±

\*BRACKETS DENOTE ADJUSTED VALUE WITH CONCRETE PIPE THICKNESS

200mmØ WATERMAIN TABLE			
STATION	FINISHED GRADE	TOP W/M	ITEM
0+000	78.83	76.10±	CONNECT TO EX. 200mmØ PVC WATERMAIN
0+003.4	78.93	76.30	200mmØ TEE
0+003.9	78.95	76.50	200mmØ VALVE AND VALVE BOX
0+004.4	78.96	76.50	200mmØ TEE
0+020	79.43	77.20	TOP OF PIPE
0+040	80.50	78.10	TOP OF PIPE
0+055.4	80.63	78.20	150mmØ HYDRANT TEE
0+063.7	80.56	78.14	200mmØ TEE
0+064.2	80.57	78.17	200mmØ VALVE AND VALVE BOX
0+064.7	80.58	78.18	200mmØ TEE
0+080	80.72	78.32	TOP OF PIPE
0+100	80.85	78.40	TOP OF PIPE
0+113.3	80.99	78.50	200mmØ TEE
0+113.8	80.99	78.50	200mmØ VALVE AND VALVE BOX
0+114.3	81.00	78.60	200mmØ TEE
0+116.1	81.45	79.50	45° HORIZONTAL BEND
0+119	81.89	79.40	22.5° HORIZONTAL BEND
0+122.5	82.72	81.32	11.25° HORIZONTAL BEND
0+140	83.82	81.42	TOP OF PIPE
0+160	83.88	81.48	TOP OF PIPE
0+180.4	83.44	81.04	W3 WATER CHAMBER
0+185.4	83.33	80.93	11.25° HORIZONTAL BEND
0+188.4	83.25	81.25±	200mmØ TEE CONNECTION TO EXISTING

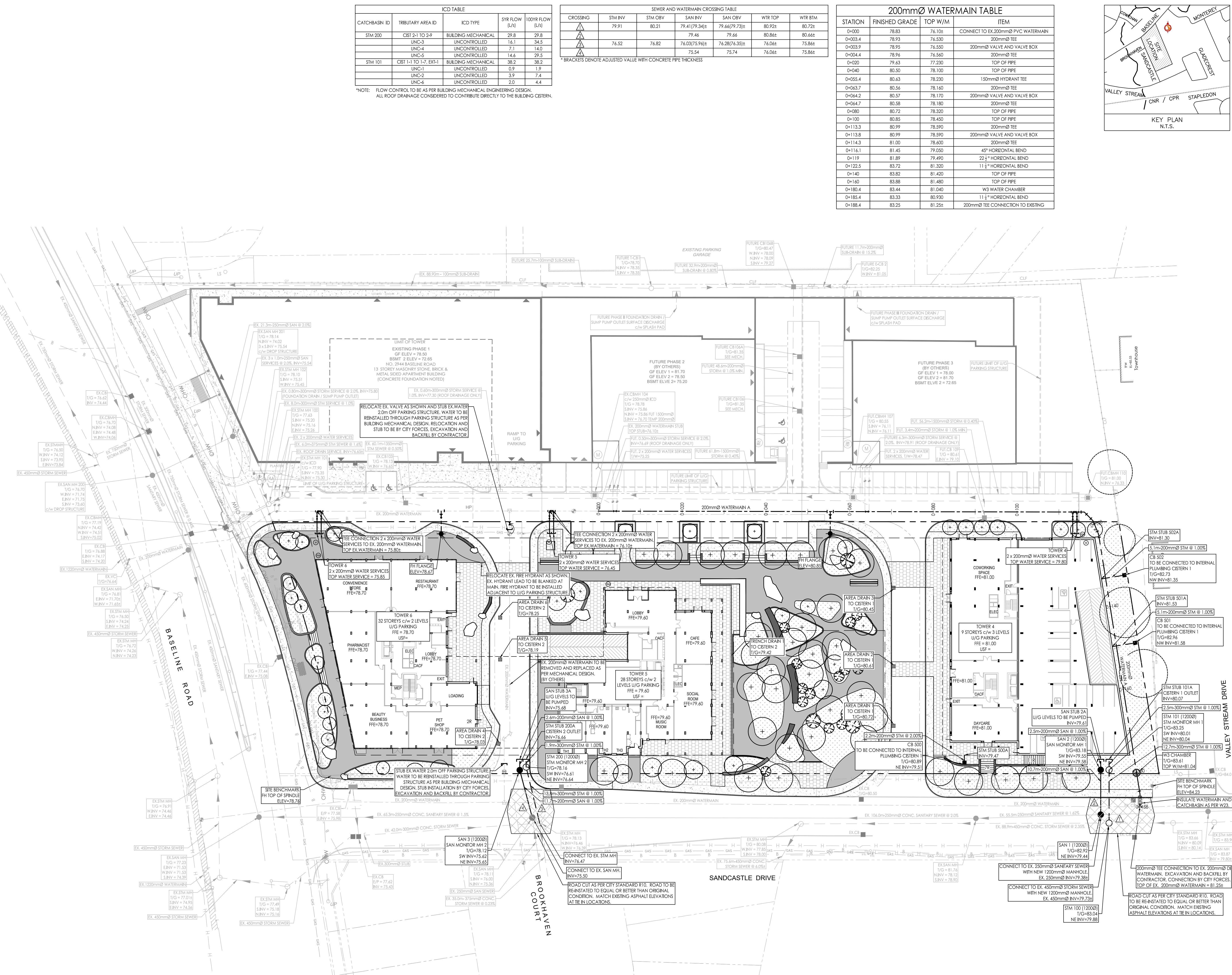
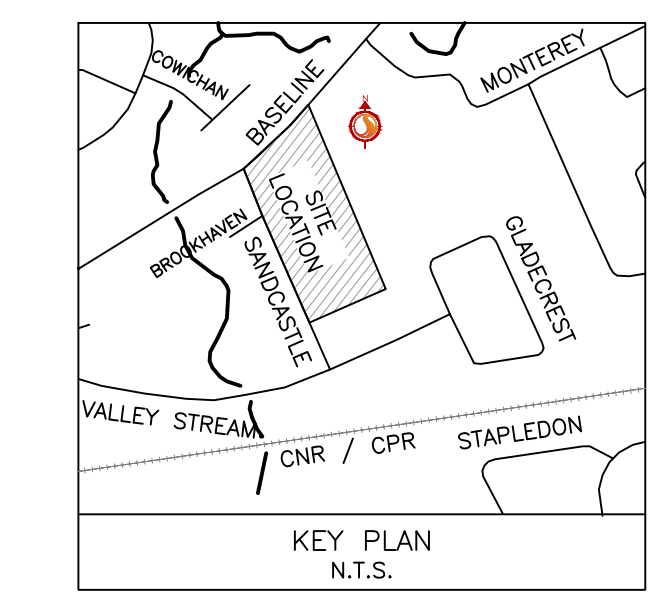

V:\01\160401676\160401676 Design\Drawings\160401676 D8.dwg  
 2023/05/25 10:51 AM by: [redacted]  
 ORIGINAL SHEET - ARCH D



Copyright Reserved

The Contractor shall verify and be responsible for all dimensions. DO NOT scale the drawing - any errors or omissions shall be reported to Stantec without delay.  
The Copyrights to all designs and drawings are the property of Stantec. Reproduction or use for any purpose other than that authorized by Stantec is forbidden.



Legend

- ORIGINAL GROUND ELEVATION
- PROPOSED ELEVATION
- PROPOSED LOT CORNER ELEVATION
- EXISTING ELEVATION AT LOT CORNER
- FLOW DIRECTION AND GRADE
- FINISHED FIRST FLOOR ELEVATION
- UNDERSIDE OF FOOTING ELEVATION
- ENGINEER FILL REQUIRED
- TERRACING 3:1 SLOPE MAXIMUM (UNLESS OTHERWISE SHOWN)
- DIRECTION OF OVERLAND FLOW
- PROPOSED VALVE BOX
- PROPOSED VALVE CHAMBER
- PROPOSED FIRE HYDRANT
- PROPOSED SANITARY SEWER MANHOLE
- PROPOSED STORM SEWER MANHOLE
- PROPOSED CATCHBASIN MANHOLE
- PROPOSED CATCHBASIN
- PROPOSED DEPRESSED CURB LOCATION
- PROPOSED BARRIER CURB
- PROPOSED ASPHALT ACCESS LANES
- OVERLAND SPILL LOCATION
- TWS LOCATION AS PER CITY STD

Notes

- PAVEMENT STRUCTURE - CAR PARKING AREAS**  
50mm SUPERPAVE 12.5 ASPHALTIC CONCRETE  
150 OPSS GRANULAR 'A' BASE  
300 OPSS GRANULAR 'B' TYPE II
- PAVEMENT STRUCTURE - ACCESS LANES AND HEAVY TRUCK**  
40mm SUPERPAVE 12.5 ASPHALTIC CONCRETE  
50mm SUPERPAVE 19.0 ASPHALTIC CONCRETE  
150 OPSS GRANULAR 'A' BASE  
450 OPSS GRANULAR 'B' TYPE II

Revision	By	App'd.	YY.MM.DD
0 ISSUED FOR SPA	MJS	RB	23.05.25
1	MJS	RB	23.03.31

Permit-Seal



Client/Project

BRIGIL HOMES

BASELINE TOWERS 4-5-6  
2946 BASELINE ROAD  
OTTAWA, ON, CANADA

Title

GRADING PLAN

Project No. 160401676	Scale 1:400	Sheet 12	Revision 0
--------------------------	----------------	-------------	---------------

Drawing No. GP-1 4 of 7



\1\1\06\1676\1676.dwg  
 2023/05/25 11:51 AM RJP  
 ORIGINAL SHEET - ARCH D

Copyright Reserved

The Contractor shall verify and be responsible for all dimensions. DO NOT scale the drawings - any errors or omissions shall be reported to Stantec without delay. The Copyrights to all designs and drawings are the property of Stantec. Reproduction or use for any purpose other than that authorized by Stantec is forbidden.

Legend

- PROPOSED SILT FENCE BOUNDARY AS PER OPSD 219.110
- PROPOSED CATCH BASIN PROTECTION AS PER TERRAFIX SILTSACK DETAIL
- PROPOSED MUD MAT LOCATION
- PROPOSED VALVE BOX
- PROPOSED VALVE CHAMBER
- PROPOSED FIRE HYDRANT
- PROPOSED SANITARY SEWER MANHOLE
- PROPOSED STORM SEWER MANHOLE
- PROPOSED CATCHBASIN

Best Management Practices

CONTRACTOR TO PROVIDE EROSION AND SEDIMENT CONTROLS (BEST MANAGEMENT PRACTICES) DURING CONSTRUCTION OF THIS PROJECT.

EROSION MUST BE MINIMIZED AND SEDIMENTS MUST BE REMOVED FROM CONSTRUCTION SITE RUN-OFF IN ORDER TO PROTECT DOWNSTREAM AREAS. DURING ALL CONSTRUCTION, EROSION AND SEDIMENTATION SHOULD BE CONTROLLED BY THE FOLLOWING TECHNIQUES:

1. LIMIT THE EXTENT OF EXPOSED SOILS AT ANY GIVEN TIME.
2. REVEGETATE EXPOSED AREAS AND SLOPES AS SOON AS POSSIBLE.
3. MINIMIZE AREA TO BE CLEARED OR GRUBBED.
4. PROTECT EXPOSED SOILS WITH PLASTIC OR SYNTHETIC MULCHES.
5. INSTALL CATCH BASIN INSERTS OR EQUIVALENT IN ALL PROPOSED CATCH BASINS AND CATCH BASIN MANHOLES AND IN ALL EXISTING CATCH BASINS THAT WILL RECEIVE RUN-OFF FROM THE SITE.
6. A SILT FENCE SHALL BE INSTALLED AROUND THE PERIMETER OF ALL AND ANY STOCKPILES OF MATERIAL TO BE USED OR REMOVED FROM SITE. (LOCATION TO BE DETERMINED)
7. A VISUAL INSPECTION SHALL BE DONE DAILY ON SEDIMENT CONTROL MEASURES AND CLEANED OF ANY ACCUMULATED SILT AS REQUIRED. THE DEPOSITS WILL BE DISPOSED OFF SITE AS PER THE REQUIREMENTS OF THE CONTRACT.
8. SEDIMENT CONTROL BARRIERS MAY ONLY BE REMOVED TEMPORARILY WITH APPROVAL OF CONTRACT ADMINISTRATOR TO ACCOMMODATE CONSTRUCTION OPERATIONS. ALL AFFECTED BARRIERS MUST BE REINSTATED AT NIGHT WHEN CONSTRUCTION IS COMPLETED. NO REMOVAL WILL OCCUR IF THERE IS A SIGNIFICANT RAINFALL EVENT ANTICIPATED (>10mm) UNLESS A NEW DEVICE HAS BEEN INSTALLED TO PROTECT EXISTING STORM AND SANITARY SEWER SYSTEMS, OR DOWNSTREAM WATERCOURSES.
9. NO REFUELING OR CLEANING OF EQUIPMENT IS PERMITTED NEAR ANY EXISTING WATERWAY.
10. CONTRACTOR SHALL REMOVE SEDIMENT CONTROL MEASURES WHEN, IN THE OPINION OF THE CONTRACT ADMINISTRATOR, THE MEASURES IS NO LONGER REQUIRED. NO CONTROL MEASURES SHALL BE PERMANENTLY REMOVED WITHOUT PRIOR WRITTEN AUTHORIZATION FROM THE CONTRACT ADMINISTRATOR.
11. THE CONTRACTOR SHALL PERIODICALLY, OR WHEN REQUESTED BY THE CONTRACT ADMINISTRATOR, CLEAN OUT ACCUMULATED SEDIMENTS AS REQUIRED.
12. THE CONTRACTOR SHALL IMMEDIATELY REPORT TO THE ENGINEER ANY ACCIDENTAL DISCHARGES OF SEDIMENT MATERIAL INTO THE WATERCOURSE. APPROPRIATE RESPONSE MEASURES, INCLUDING ANY REPAIRS TO EXISTING CONTROL MEASURES OR THE IMPLEMENTATION OF ADDITIONAL CONTROL MEASURES, SHALL BE CARRIED OUT BY THE CONTRACTOR WITHOUT DELAY.
13. CONTRACTOR SHALL INSTALL MUD MAT AT CONSTRUCTION ENTRANCE TO THE SITE.

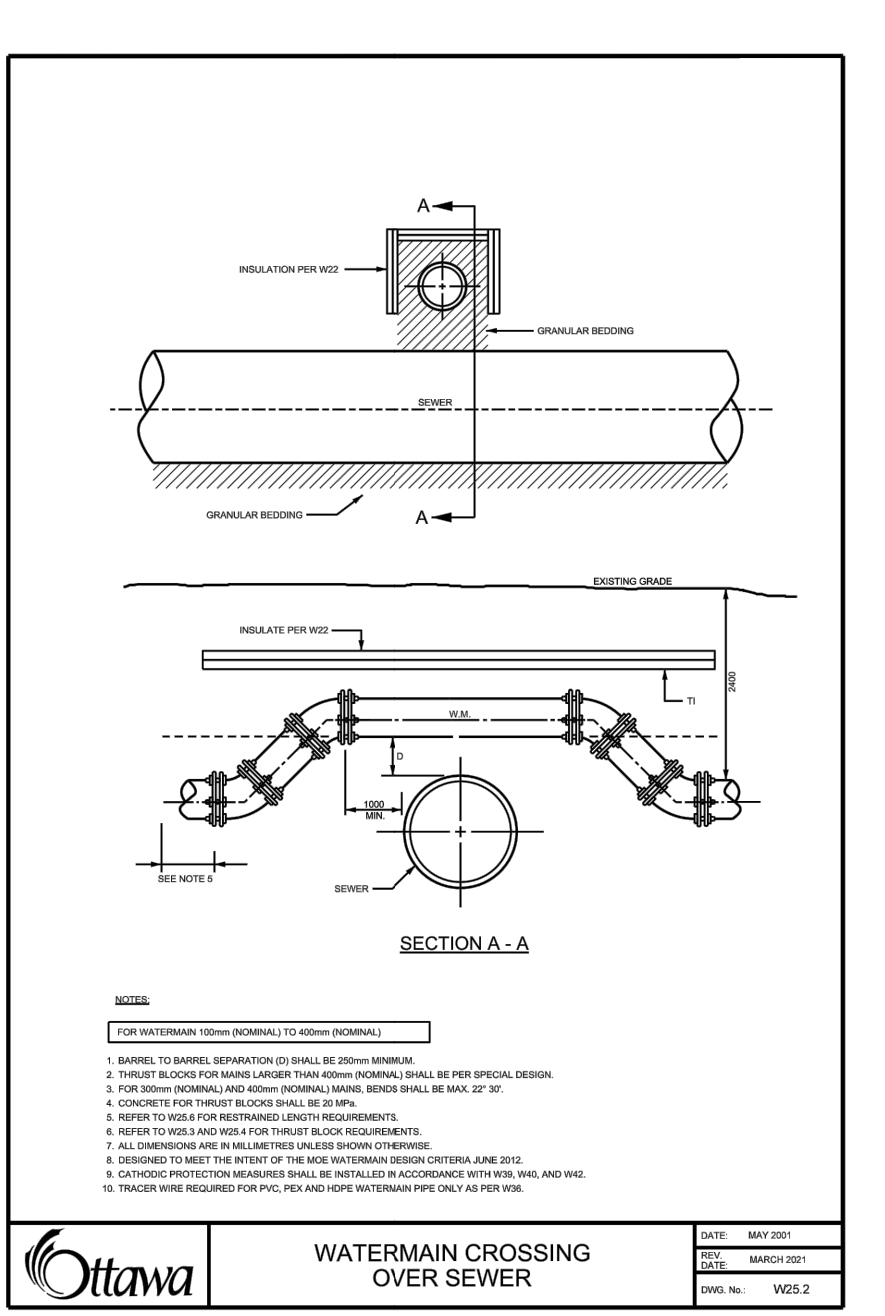
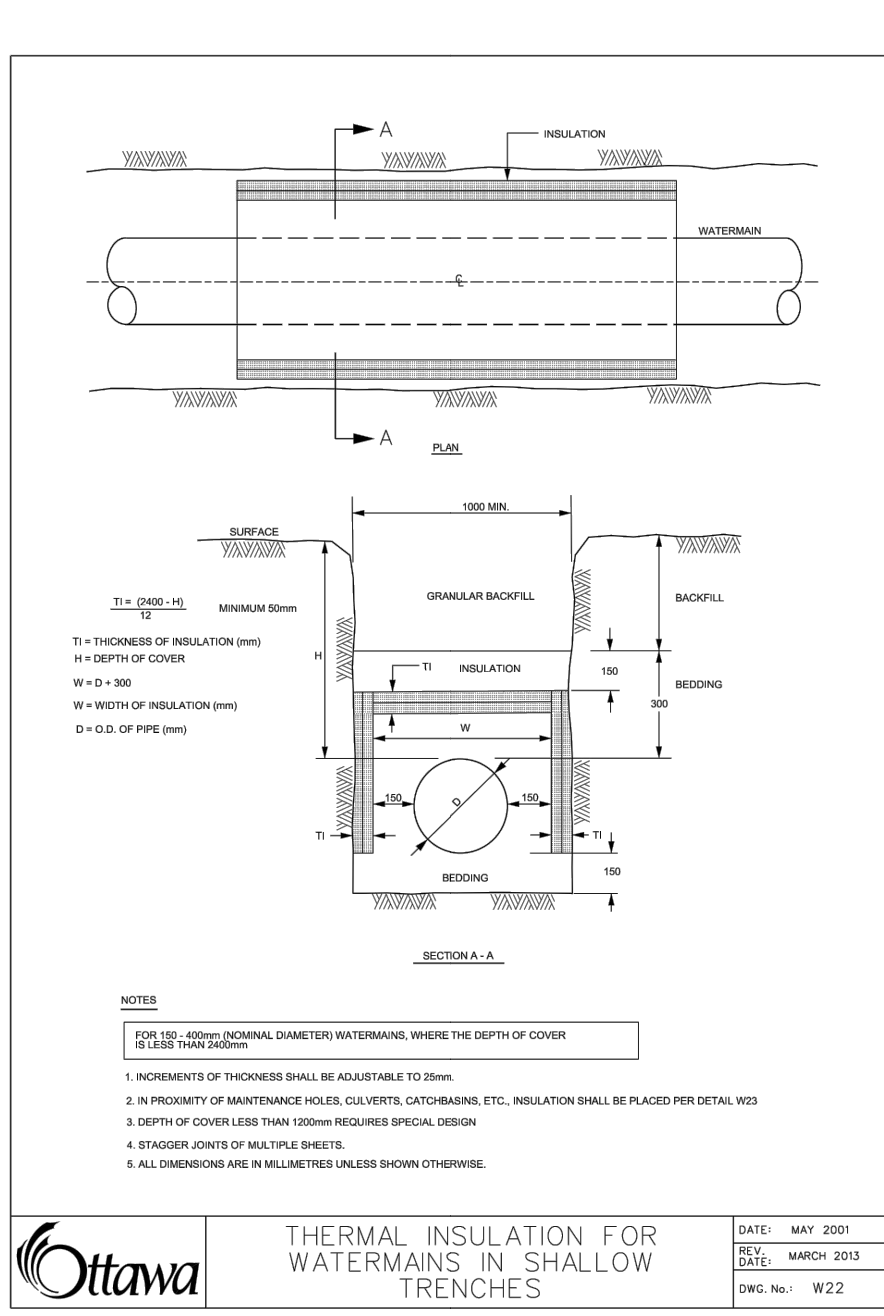
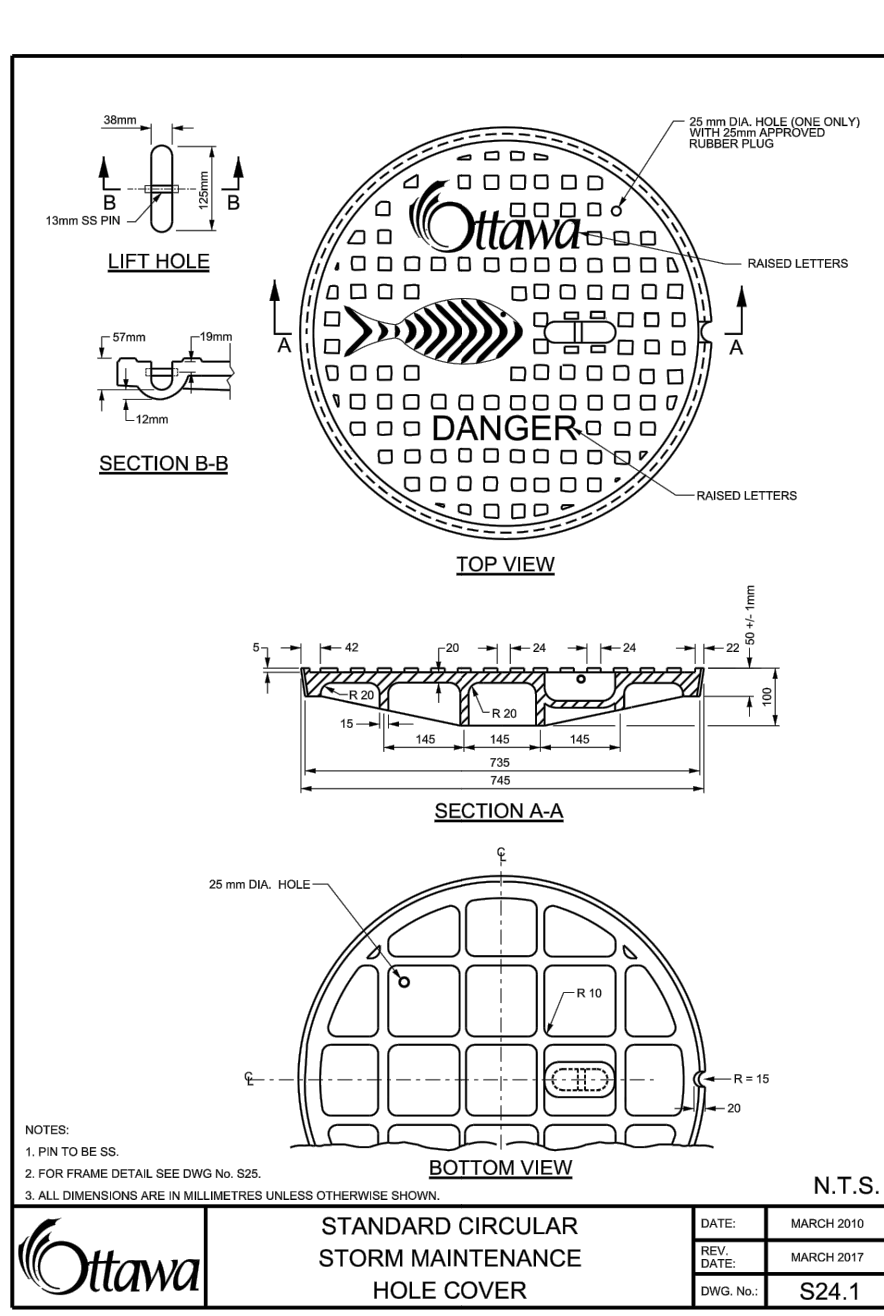
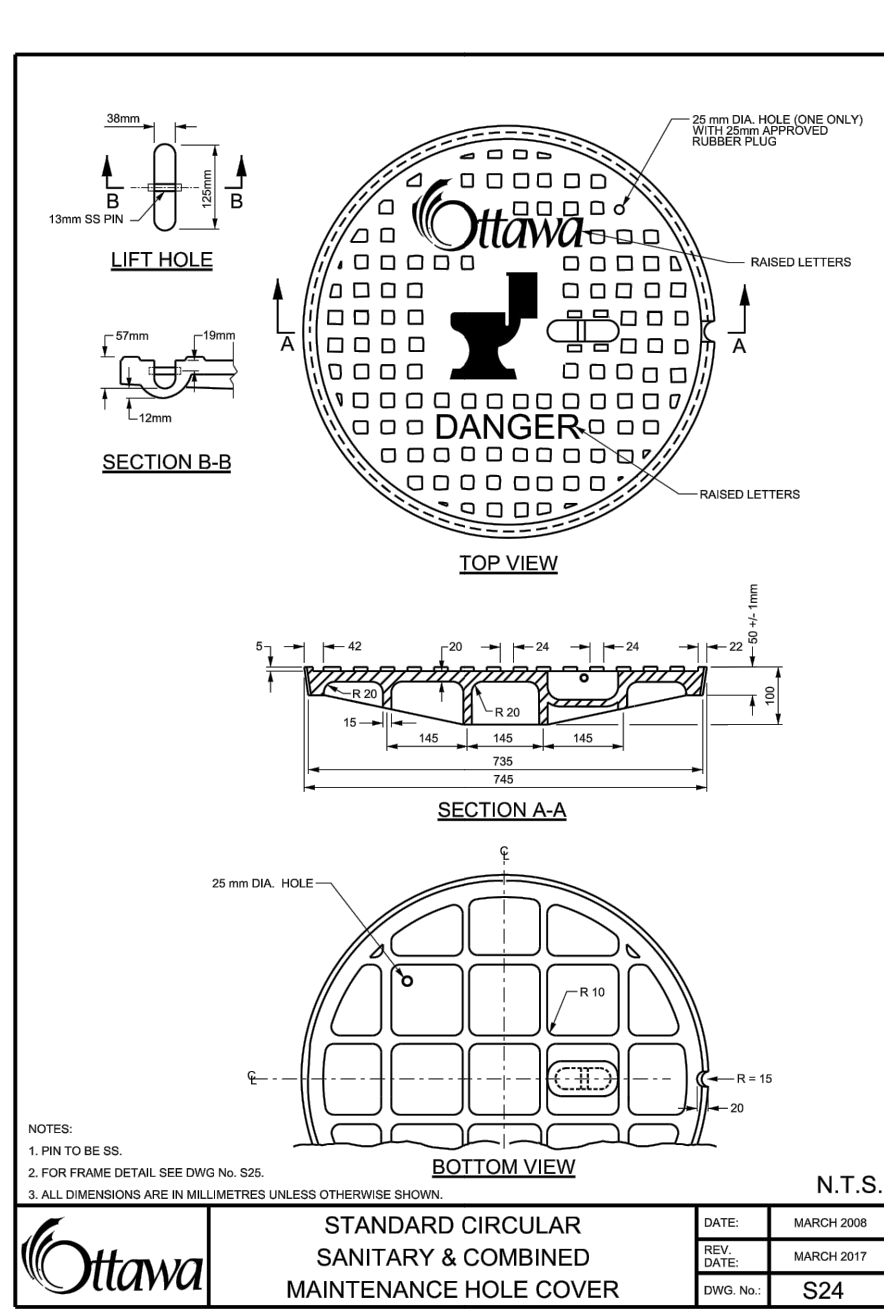
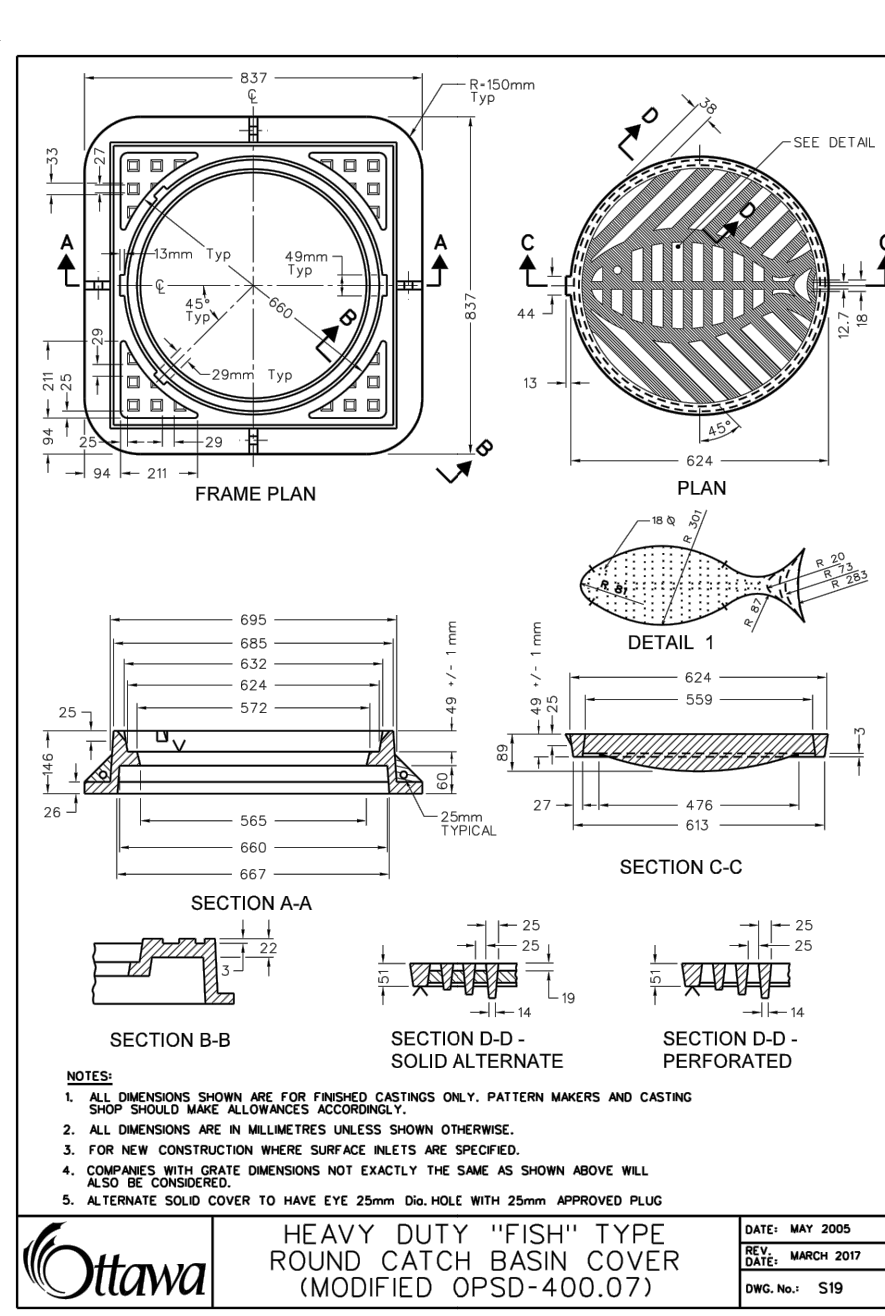
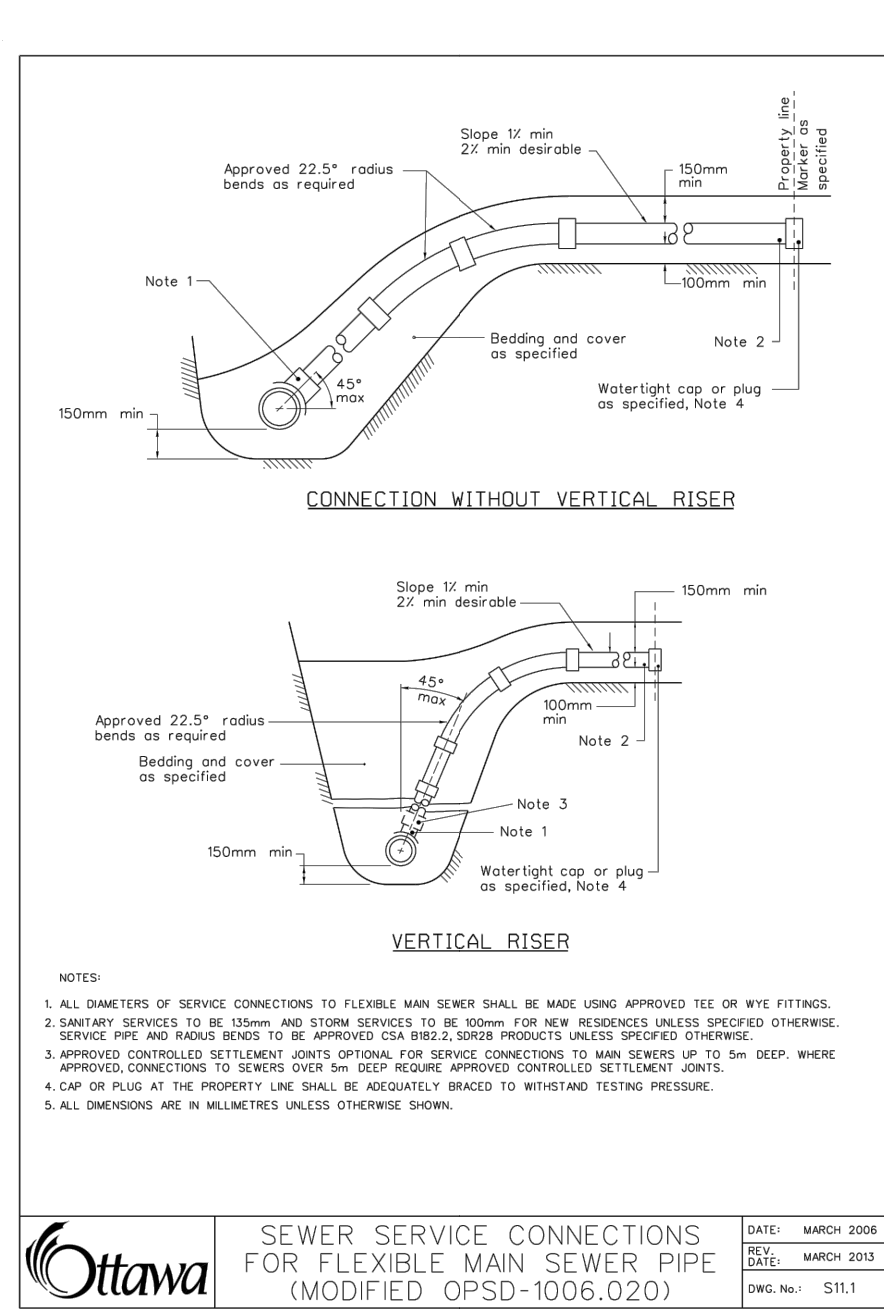
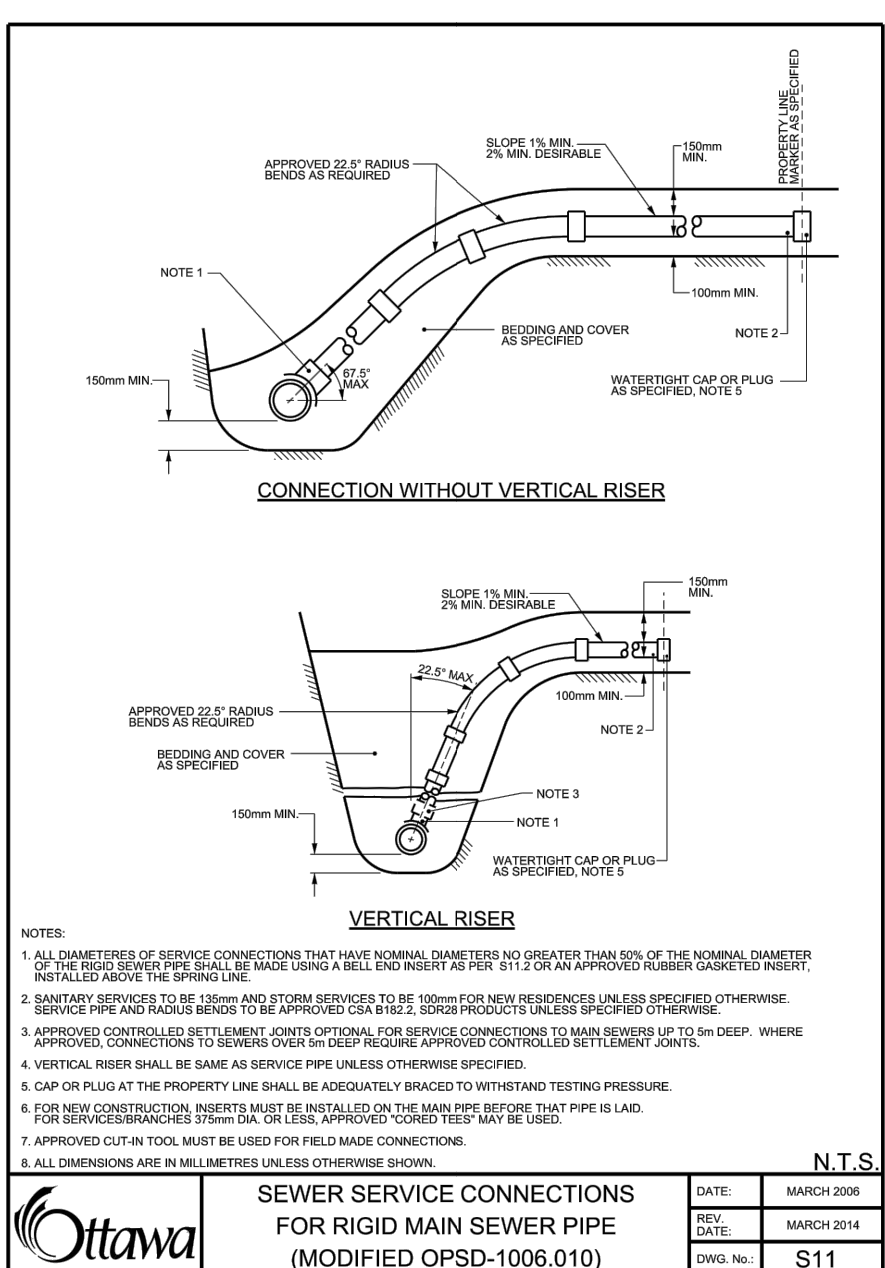
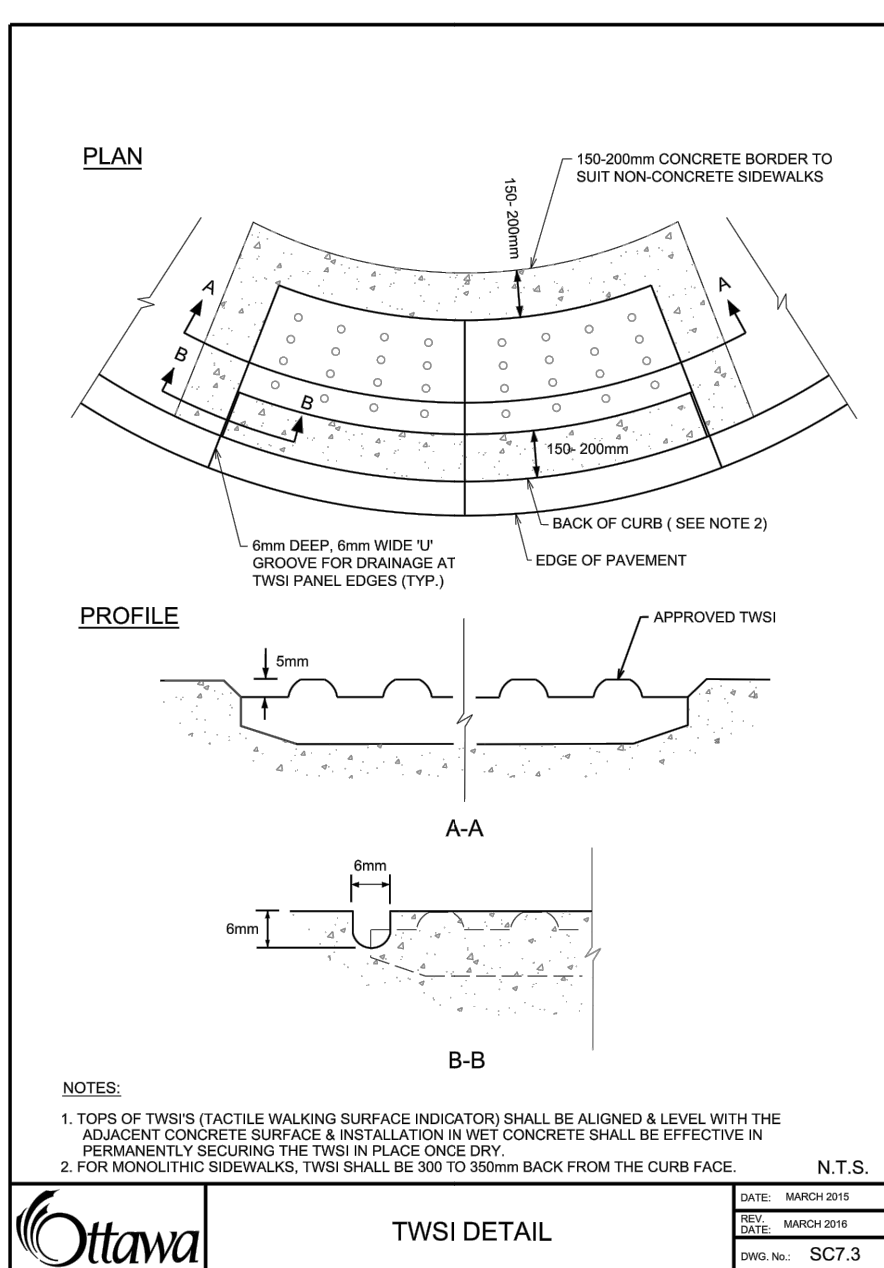
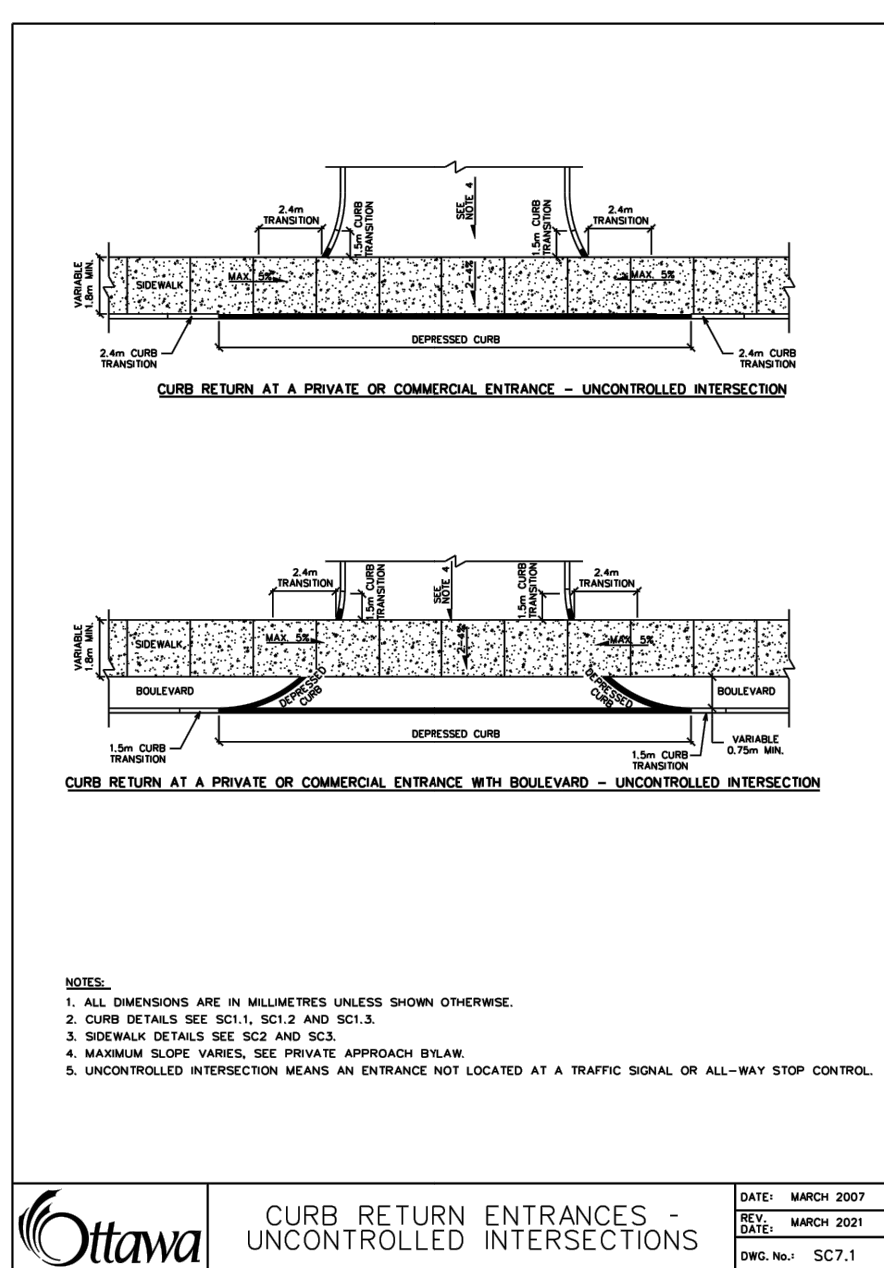
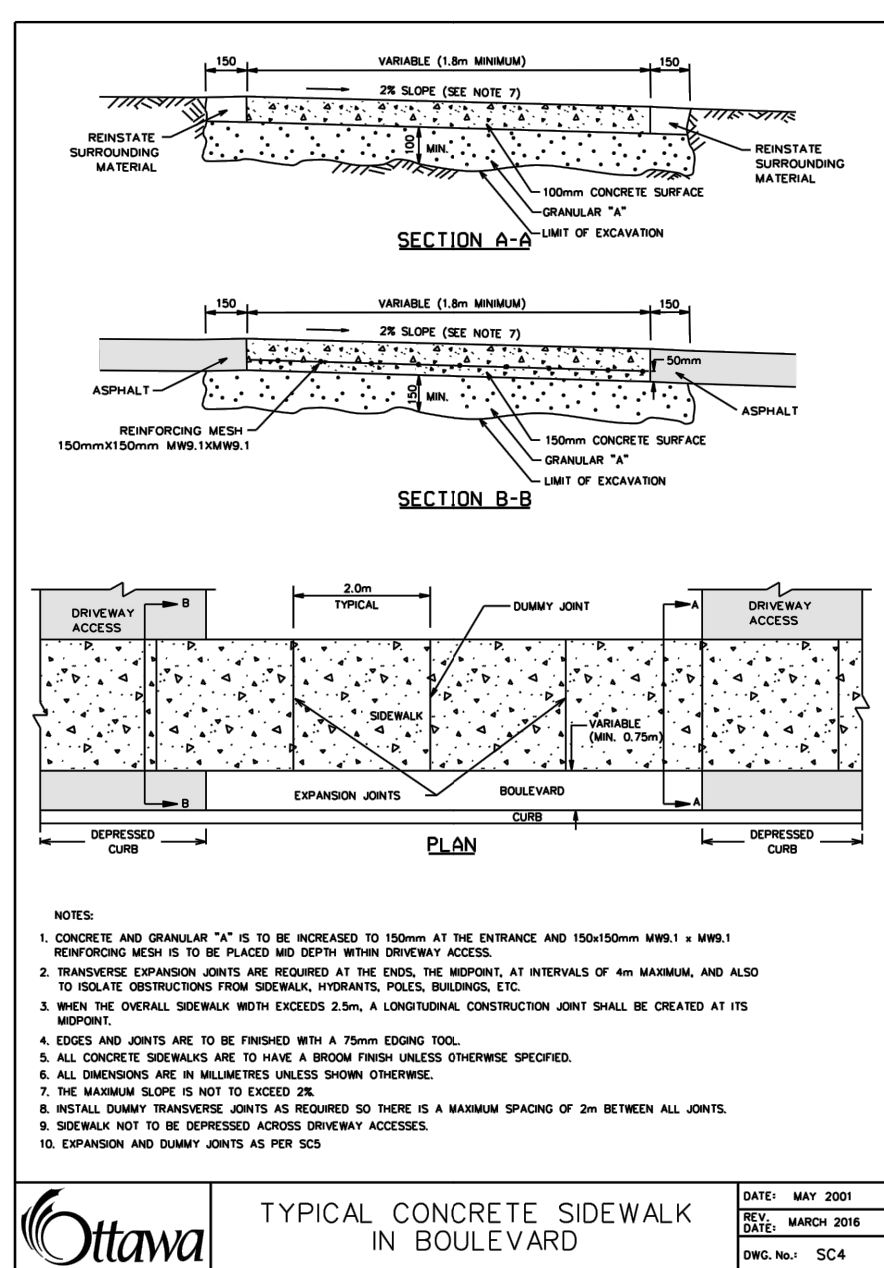
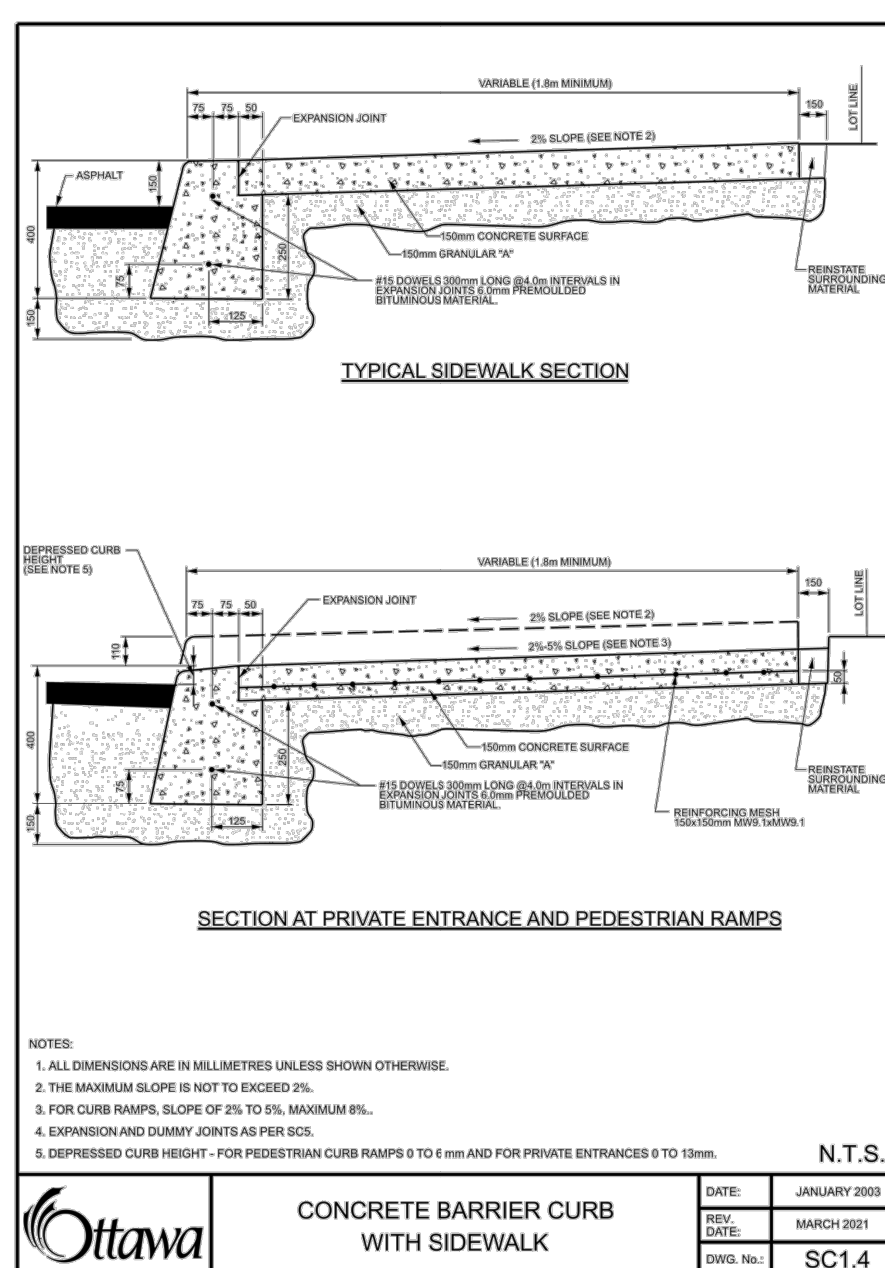
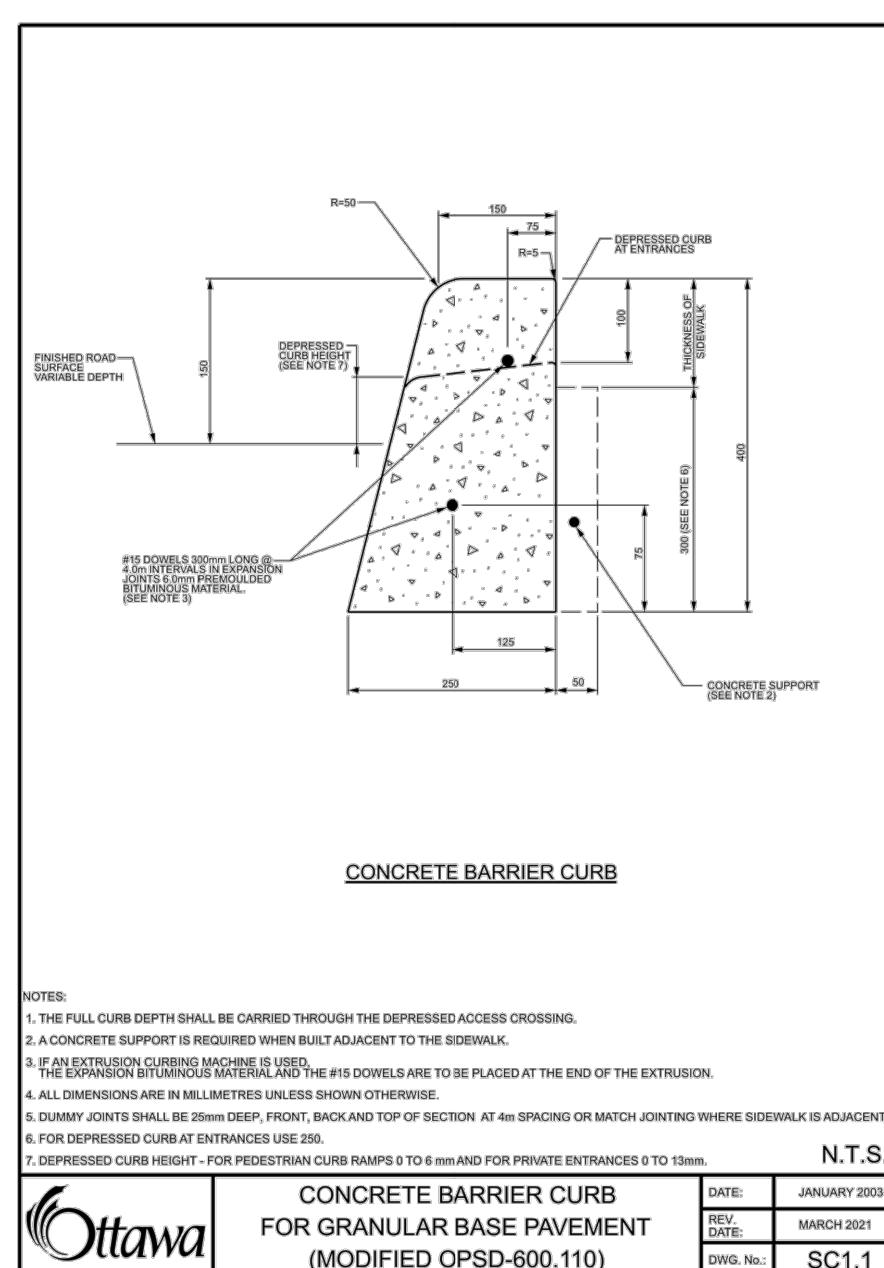
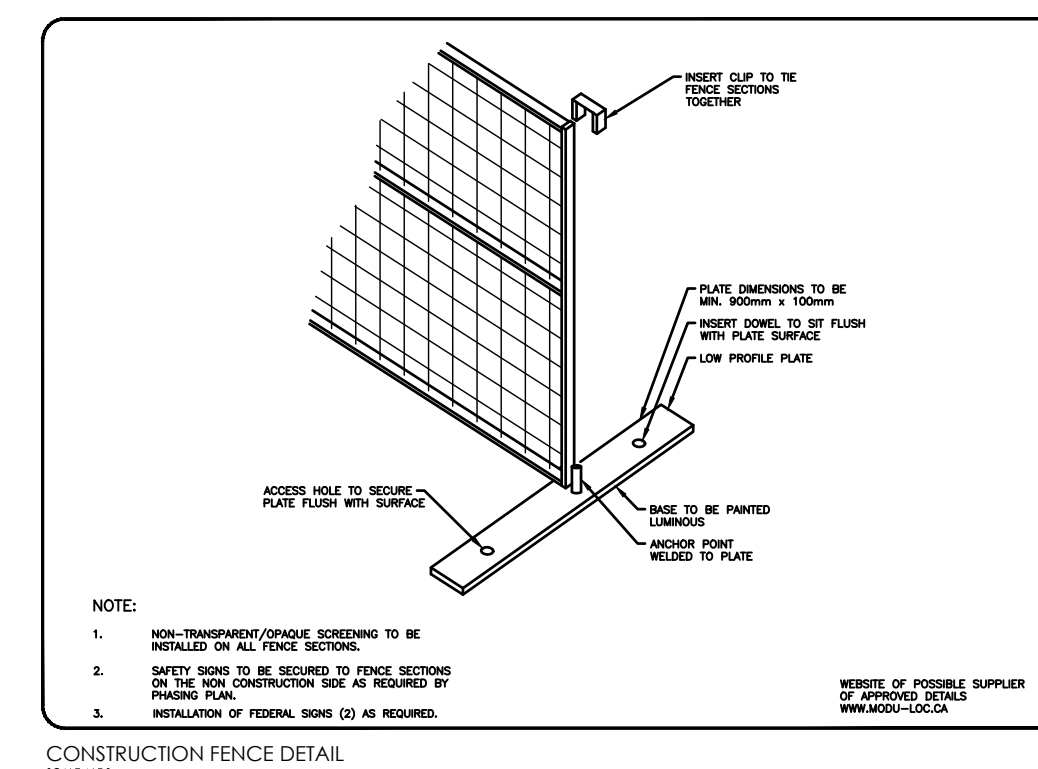
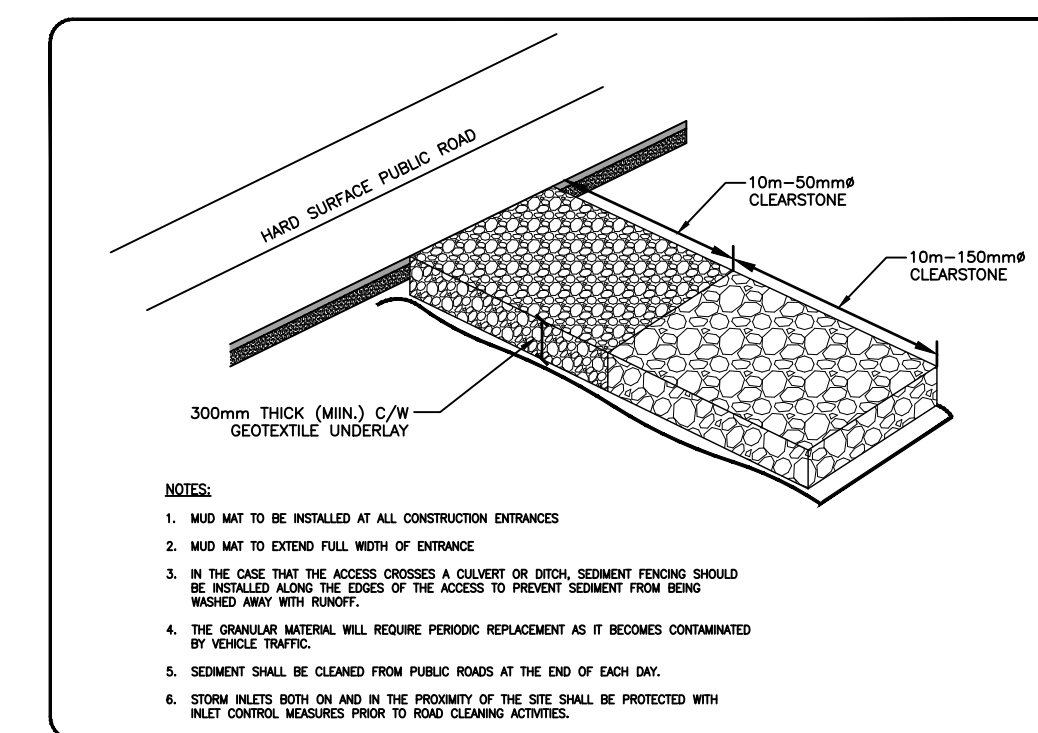
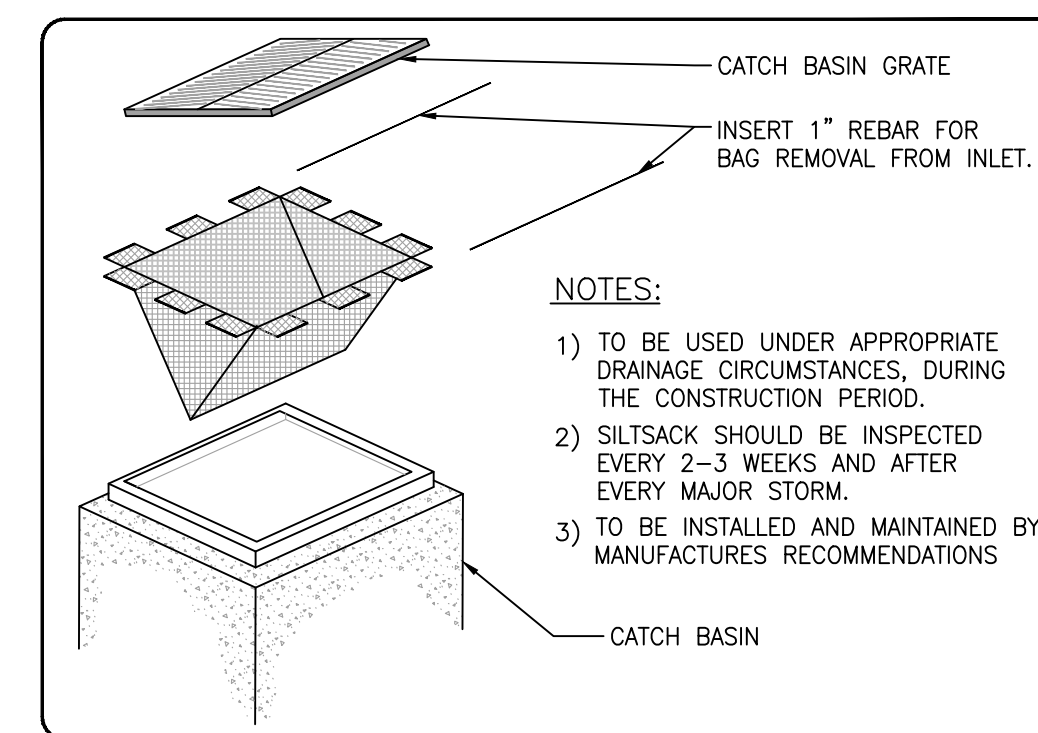
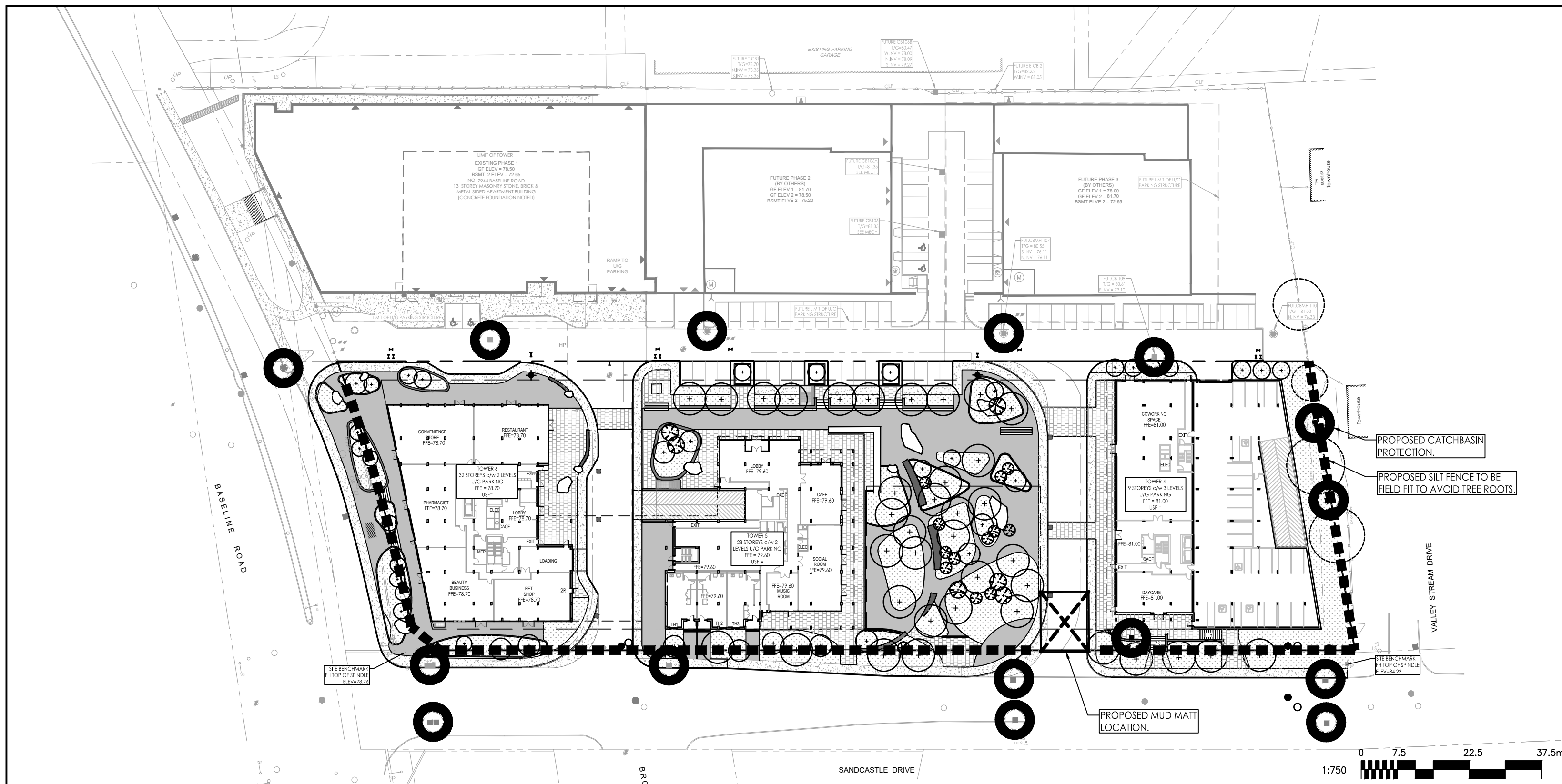

Revision	By	App'd.	YY.MM.DD	
0	ISSUED FOR SPA	MJS	RB	23.05.25

File Name	MJS	RB	MJS	23.03.31
160401676 DB.dwg	Dwn.	Chkd.	Dgn.	YY.MM.DD



Client/Project  
**BRIGIL HOMES**  
  
BASELINE TOWERS 4-5-6  
2946 BASELINE ROAD  
OTTAWA, ON, CANADA

Project No.	Scale
160401676	

Drawing No.	Sheet	Revision
EC/DS-1	5 of 7	0



Copyright Reserved

The Contractor shall verify and be responsible for all dimensions. DO NOT scale the drawing - any errors or omissions shall be reported to Stantec without delay.  
The Copyrights to all designs and drawings are the property of Stantec. Reproduction or use for any purpose other than that authorized by Stantec is forbidden.

ICD TABLE				
CATCHBASIN ID	TRIBUTARY AREA ID	ICD TYPE	SYR FLOW (L/s)	100YR FLOW (L/s)
STM 200	CIST 2-1 TO 2-9	BUILDING MECHANICAL	29.8	29.8
	UNC-3	UNCONTROLLED	16.1	34.5
	UNC-4	UNCONTROLLED	7.1	14.0
STM 101	UNC-5	UNCONTROLLED	14.6	29.5
	CIST 1-1 TO 1-7, EXT-1	BUILDING MECHANICAL	38.2	38.2
	UNC-1	UNCONTROLLED	0.9	1.9
	UNC-2	UNCONTROLLED	3.9	7.4
	UNC-6	UNCONTROLLED	2.0	4.4

\*NOTE: FLOW CONTROL TO BE AS PER BUILDING MECHANICAL ENGINEERING DESIGN.  
ALL ROOF DRAINAGE CONSIDERED TO CONTRIBUTE DIRECTLY TO THE BUILDING CISTERN.

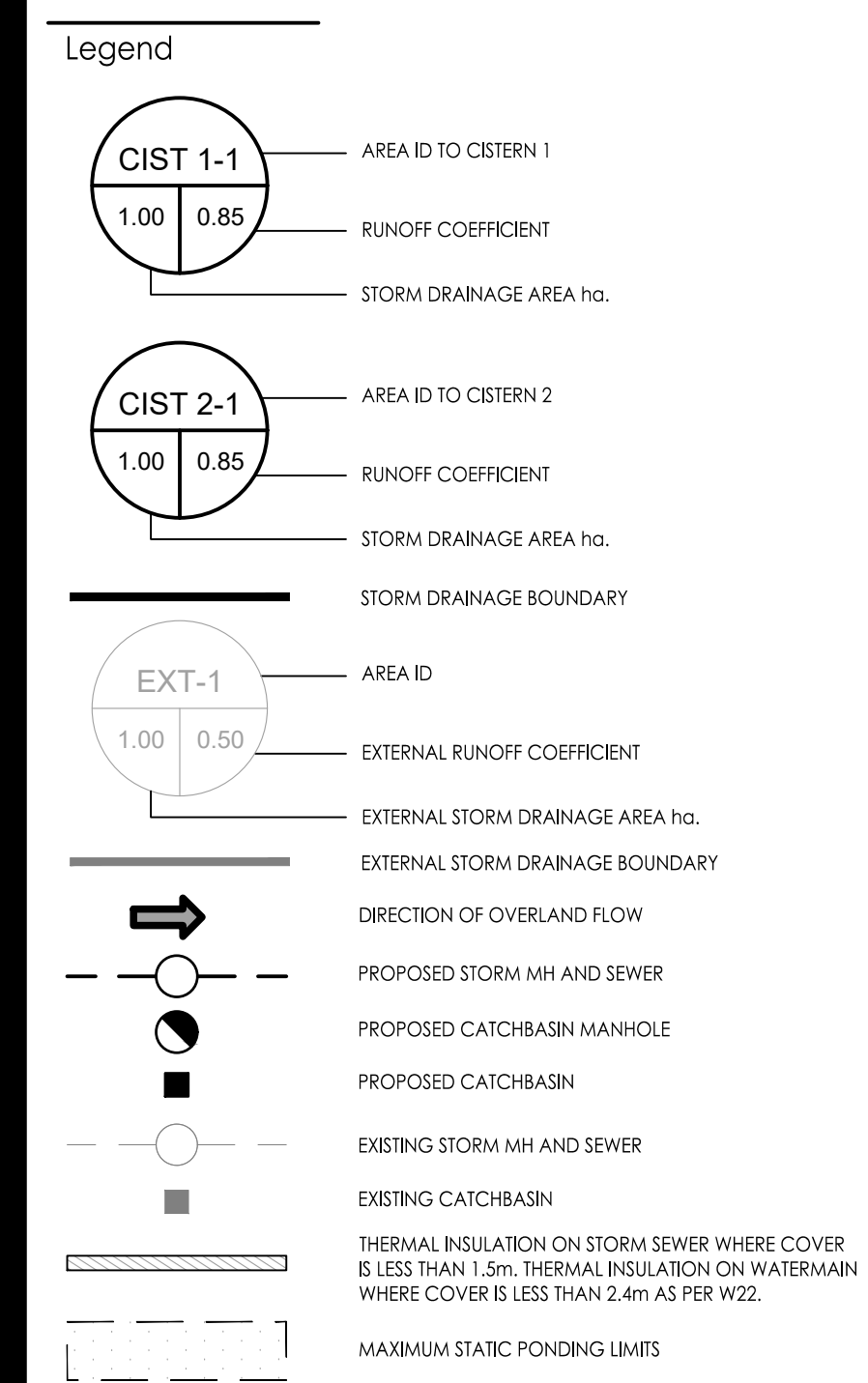
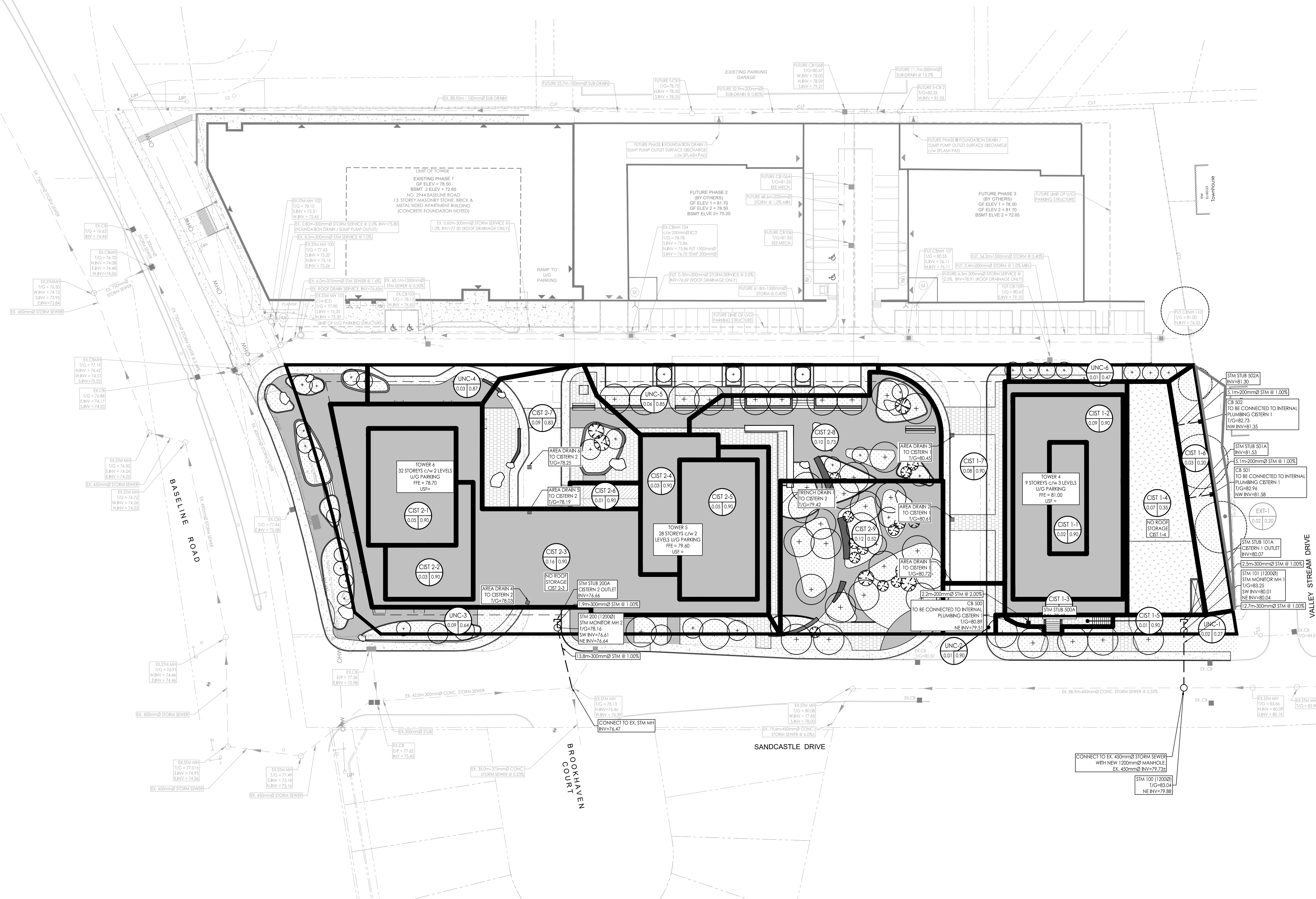
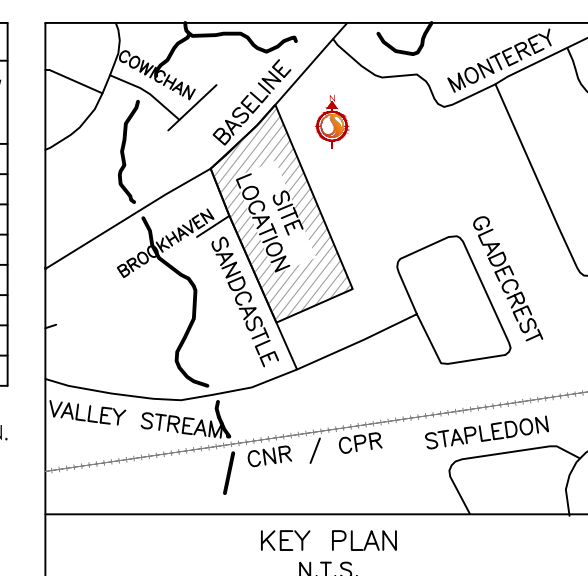

- Notes**
- ALL CATCH BASINS, AREA DRAINS AND TRENCH DRAINS TO BE CONNECTED TO INTERNAL PLUMBING AND COLLECTED IN STORM WATER MANAGEMENT CISTERNS. STORMWATER MANAGEMENT TO BE PROVIDED THROUGH 2 CISTERNS.
  - PHASE 4 CISTERN = 74.0 m<sup>3</sup>  
PHASE 5 + 6 CISTERN = 251.0 m<sup>3</sup>  
MAX. CISTERN RELEASE RATE TO STORM SEWER  
PHASE 4 CISTERN RELEASE RATE = 38.2 L/s  
PHASE 5 + 6 CISTERN RELEASE RATE = 29.8 L/s  
CISTERN STORAGE AND RELEASE RATE CONTROL AS PER BUILDING MECHANICAL ENGINEERING DESIGN.

Revision	By	Appd.	YY.MM.DD
0 ISSUED FOR SPA	MJS	RB	23.05.25

Permit-Seal



Client/Project  
**BRIGIL HOMES**

**BASELINE TOWERS 4-5-6**  
2946 BASELINE ROAD  
OTTAWA, ON, CANADA

Title  
**STORM DRAINAGE PLAN**

Project No. 160401676	Scale 1:400	Sheet 6 of 7	Revision 0
--------------------------	----------------	-----------------	---------------

SD-1 6 of 7 0

\\s1\p01\proj\160401676\design\drawing\160401676\_DB.dwg  
2023/05/25 10:52 AM RJP

ORIGINAL SHEET - ARCH D



Copyright Reserved

The Contractor shall verify and be responsible for all dimensions. DO NOT scale the drawing - any errors or omissions shall be reported to Stantec without delay.  
The Copyrights to all designs and drawings are the property of Stantec. Reproduction or use for any purpose other than that authorized by Stantec is forbidden.

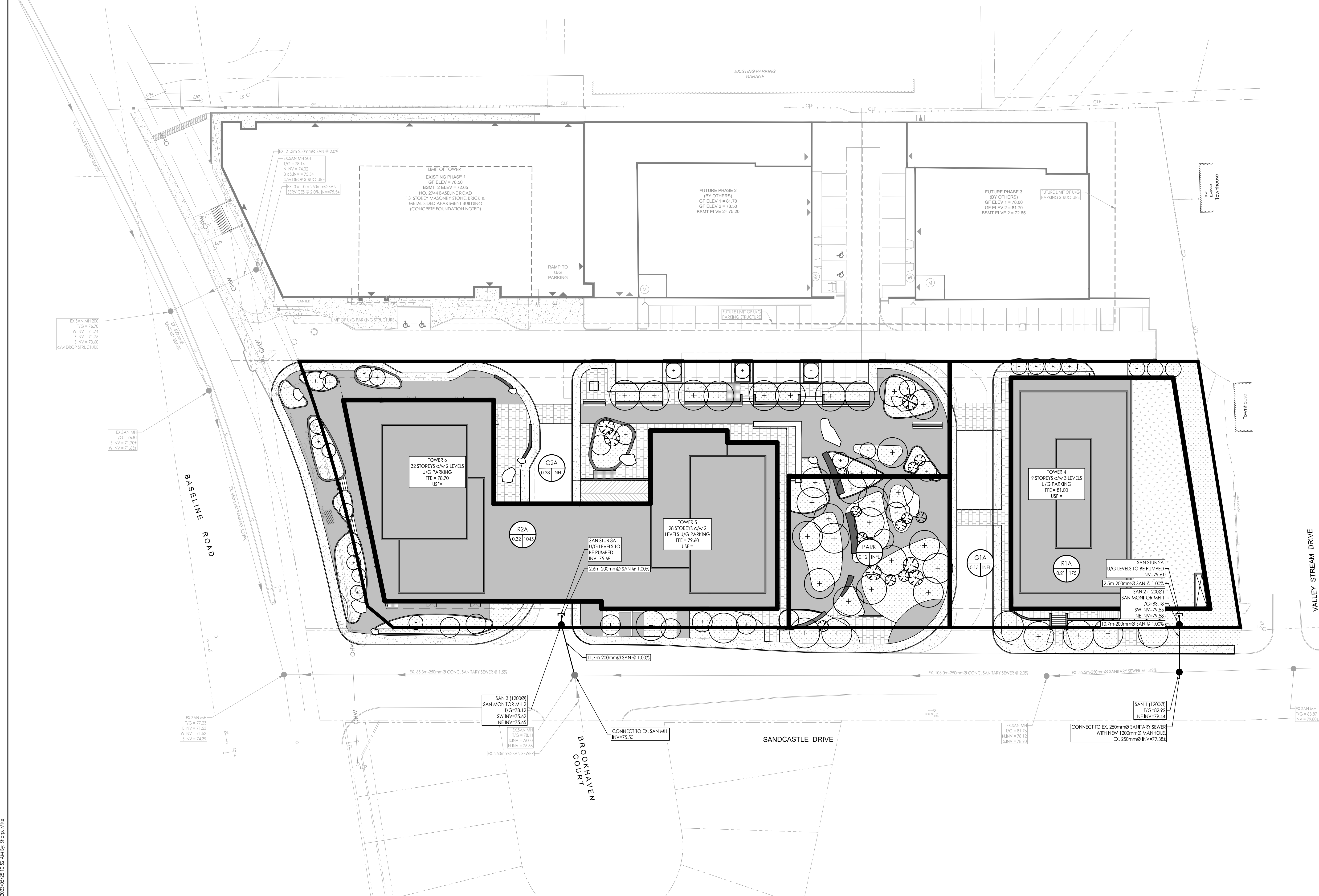

Legend

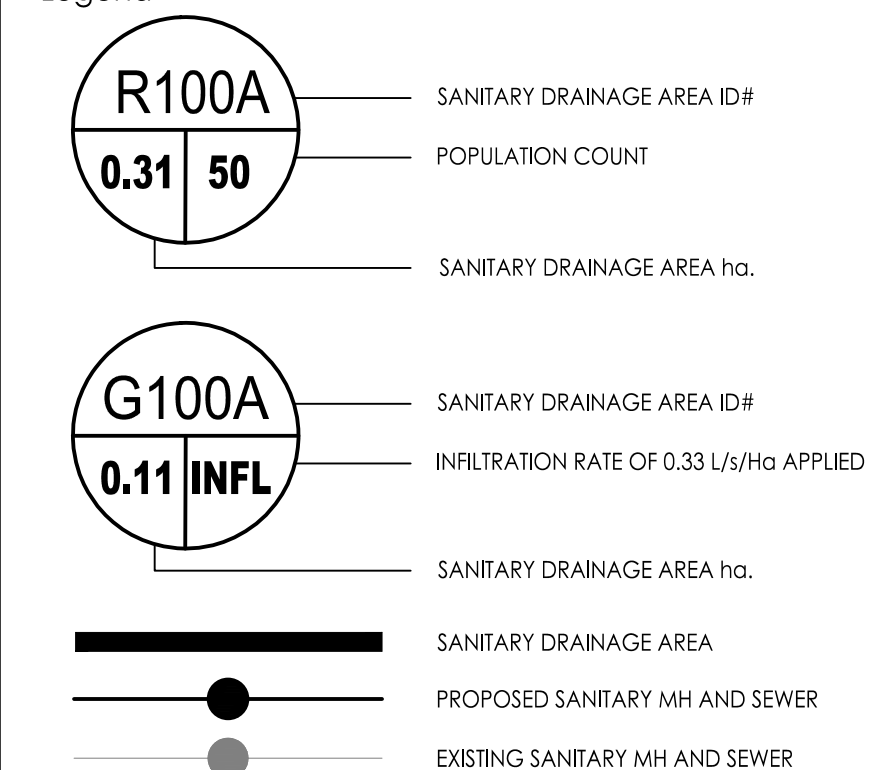

Notes

SANITARY STATS	
<b>POPULATION COUNT</b>	
<b>TOWER 4</b>	
75 - 1 BEDROOM APTS @ 1.4PPU = 105 PEOPLE	
20 - 2 BEDROOM APTS @ 2.1PPU = 42 PEOPLE	
9 - 3 BEDROOM APTS @ 3.1PPU = 28 PEOPLE	
<b>TOTAL POPULATION TOWER 4 = 175 PEOPLE</b>	
<b>TOWER 5</b>	
147 - 1 BEDROOM APTS @ 1.4PPU = 204 PEOPLE	
96 - 2 BEDROOM APTS @ 2.1PPU = 202 PEOPLE	
15 - 3 BEDROOM APTS @ 3.1PPU = 47 PEOPLE	
3 - TOWNHOUSE UNITS @ 2.7PPU = 8.0 PEOPLE	
<b>TOTAL POPULATION TOWER 5 = 491 PEOPLE</b>	
<b>TOWER 6</b>	
174 - 1 BEDROOM APTS @ 1.4PPU = 244 PEOPLE	
123 - 2 BEDROOM APTS @ 2.1PPU = 258 PEOPLE	
16 - 3 BEDROOM APTS @ 3.1PPU = 50 PEOPLE	
<b>TOTAL POPULATION TOWER 6 = 554 PEOPLE</b>	
<b>TOTAL POPULATION = 1220</b>	
<b>TOTAL COMMERCIAL SPACE = 1229m<sup>2</sup> (0.123ha) @ 28.00 L/ha/day</b>	

Revision	By	Appd.	YY.MM.DD
0 ISSUED FOR SPA	MJS	RB	23.05.25

File Name: 160401676 DB.dwg

Permit-Seal	Dwn.	Chkd.	Dgn.	YY.MM.DD
	MJS	RB	MJS	23.03.31



Client/Project  
**BRIGIL HOMES**  
  
BASELINE TOWERS 4-5-6  
2946 BASELINE ROAD  
OTTAWA, ON, CANADA

Title  
**SANITARY DRAINAGE PLAN**

Project No. 160401676	Scale 1:400	Sheet 7 of 7	Revision 0
--------------------------	----------------	-----------------	---------------

V:\1\160401676\160401676.dwg  
 2023/05/25 10:52 AM RJS  
 ORIGINAL SHEET - ARCH D