

265 Centrum Boulevard

Transportation Impact Assessment

Step 1 Screening Report

Step 2 Scoping Report

Step 3 Forecasting Report

Step 4 Strategy Report

Prepared for:

Bayview Orleans Inc.
108 Chestnut Street
Toronto ON M5G 1R3

Prepared by:



6 Plaza Court
Ottawa, ON K2H 7W1

March 2023

PN: 2023-013

Table of Contents

1	Screening.....	1
2	Existing and Planned Conditions.....	1
2.1	Proposed Development.....	1
2.2	Existing Conditions.....	3
2.2.1	Area Road Network.....	3
2.2.2	Existing Intersections.....	3
2.2.3	Existing Driveways.....	4
2.2.4	Cycling and Pedestrian Facilities.....	4
2.2.5	Existing Transit.....	7
2.2.6	Existing Area Traffic Management Measures.....	8
2.2.7	Existing Peak Hour Travel Demand.....	8
2.2.8	Collision Analysis.....	10
2.3	Planned Conditions.....	12
2.3.1	Changes to the Area Transportation Network.....	12
2.3.2	Other Study Area Developments.....	12
3	Study Area and Periods.....	13
3.1	Study Area.....	13
3.2	Time Periods.....	13
3.3	Horizon Years.....	13
4	Exemption Review.....	13
4.1	TIA Stepped Process.....	14
5	Development-Generated Travel Demand.....	14
5.1	Mode Shares.....	14
5.2	Trip Generation.....	15
5.3	Trip Distribution.....	17
5.4	Trip Assignment.....	17
6	Background Network Travel Demands.....	19
6.1	Transportation Network Plans.....	19
6.2	Background Growth.....	19
6.3	Other Developments.....	19
7	Demand Rationalization.....	19
7.1	2028 Future Background Operations.....	19
7.2	2033 Future Background Operations.....	21
7.3	2028 Future Total Operations.....	22
7.4	2033 Future Total Operations.....	24
7.5	Modal Share Sensitivity and Demand Rationalization Conclusions.....	26
8	Development Design.....	26
8.1	Design for Sustainable Modes.....	26
8.2	Circulation and Access.....	27
9	Parking.....	27
9.1	Parking Supply.....	27
10	Boundary Street Design.....	27

11 Access Intersections Design 27

 11.1 Location and Design of Access..... 27

 11.2 Intersection Control..... 28

 11.3 Access Intersection Design 28

 11.3.1 Future Access Intersection Operations 28

 11.3.2 Access Intersection MMLOS 28

 11.3.3 Recommended Design Elements..... 28

12 Transportation Demand Management 28

 12.1 Context for TDM 28

 12.2 Need and Opportunity..... 28

 12.3 TDM Program 28

13 Neighbourhood Traffic Management..... 29

14 Transit..... 29

 14.1 Route Capacity..... 29

 14.2 Transit Priority 29

15 Network Concept..... 29

16 Network Intersection Design..... 30

 16.1 Network Intersection Control..... 30

 16.2 Network Intersection Design..... 30

 16.2.1 2028 & 2033 Future Total Network Intersection Operations 30

 16.2.2 Network Intersection MMLOS..... 30

 16.2.3 Recommended Design Elements..... 30

17 Summary of Improvements Indicated and Modifications Options 31

18 Conclusion 34

List of Figures

Figure 1: Area Context Plan 1

Figure 2: Concept Plan..... 2

Figure 3: Existing Driveways 4

Figure 4: Study Area Pedestrian Facilities 5

Figure 5: Study Area Cycling Facilities 5

Figure 6: Existing Pedestrian Volumes 6

Figure 7: Existing Cyclist Volumes 6

Figure 8: Existing Study Area Transit Service..... 7

Figure 9: Existing Study Area Transit Stops 8

Figure 10: Existing Traffic Counts 9

Figure 11: Study Area Collision Records..... 11

Figure 12: New Site Generation Auto Volumes..... 18

Figure 13: Pass-by Auto Volumes 18

Figure 14: 2028 Future Background Volumes 20

Figure 15: 2033 Future Background Volumes 21

Figure 16: 2028 Future Total Volumes 23

Figure 17: 2033 Future Total Volumes 25

Table of Tables

Table 1: Intersection Count Date.....	8
Table 2: Existing Intersection Operations.....	9
Table 3: Study Area Collision Summary, 2016-2020	10
Table 4: Summary of Collision Locations, 2016-2020.....	11
Table 5: St Joseph Boulevard at Prestone Drive Collision Summary	12
Table 6: Exemption Review	14
Table 7: TRANS Trip Generation Manual Recommended Mode Shares – Orleans.....	15
Table 8: Proposed Development Mode Shares.....	15
Table 9: Trip Generation Person Trip Rates.....	15
Table 10: Total Person Trip Generation	16
Table 11: Internal Capture Rates.....	16
Table 12: Trip Generation by Mode	16
Table 13: OD Survey Distribution – Orleans.....	17
Table 14: Trip Assignment	17
Table 15: TRANS Regional Model Projections – Study Area Growth Rates.....	19
Table 16: Recommended Area Growth Rates	19
Table 17: 2028 Future Background Intersection Operations	20
Table 18: 2033 Future Background Intersection Operations	22
Table 19: 2028 Future Total Intersection Operations	23
Table 20: 2033 Future Total Intersection Operations	25
Table 21: Boundary Street MMLOS Analysis.....	27
Table 22: Trip Generation by Transit Mode	29
Table 23: Forecasted Site-Generated Transit Ridership.....	29
Table 24: Study Area Intersection MMLOS Analysis	30

List of Appendices

Appendix A – TIA Screening Form and Certification Form
Appendix B – Turning Movement Count Data
Appendix C – Synchro Intersection Worksheets – Existing Conditions
Appendix D – Collision Data
Appendix E – TRANS Plot
Appendix F – Background Volumes
Appendix G – Synchro Intersection Worksheets – 2028 Future Background Conditions
Appendix H – Synchro Intersection Worksheets – 2033 Future Background Conditions
Appendix I – Synchro Intersection Worksheets – 2028 Future Total Conditions
Appendix J – Synchro Intersection Worksheets – 2033 Future Total Conditions
Appendix K – MMLOS Analysis
Appendix L – TDM Checklist

1 Screening

This study has been prepared according to the City of Ottawa’s 2017 Transportation Impact Assessment (TIA) Guidelines. Accordingly, a Step 1 Screening Form has been prepared and is included as Appendix A, along with the Certification Form for the TIA Study PM. As shown in the Screening Form, a TIA is required including the Design Review component and the Network Impact Component. This study has been prepared to support a zoning bylaw amendment and site plan applications.

2 Existing and Planned Conditions

2.1 Proposed Development

The development site is located at 265 Centrum Boulevard within the Mixed-Use Centre Zone (MC14[1520] S152). The existing site was a YMCA, now closed, and it will be replaced with three towers, two residential towers including 764 units, and one mix-used tower including 363 residential units, 8,970 sq. ft retail space, and 31,570 sq. ft office space. The site plan proposes a total of 516 vehicle parking spaces and 1254 bicycle parking spaces. The preliminary accesses are proposed to include three along Brisebois Crescent, and the existing two accesses on Brisebois Crescent will be removed. Build-out is anticipated to occur in a single phase by 2028. Figure 1 illustrates the study area context. Figure 2 illustrates the proposed concept plan.

Figure 1: Area Context Plan

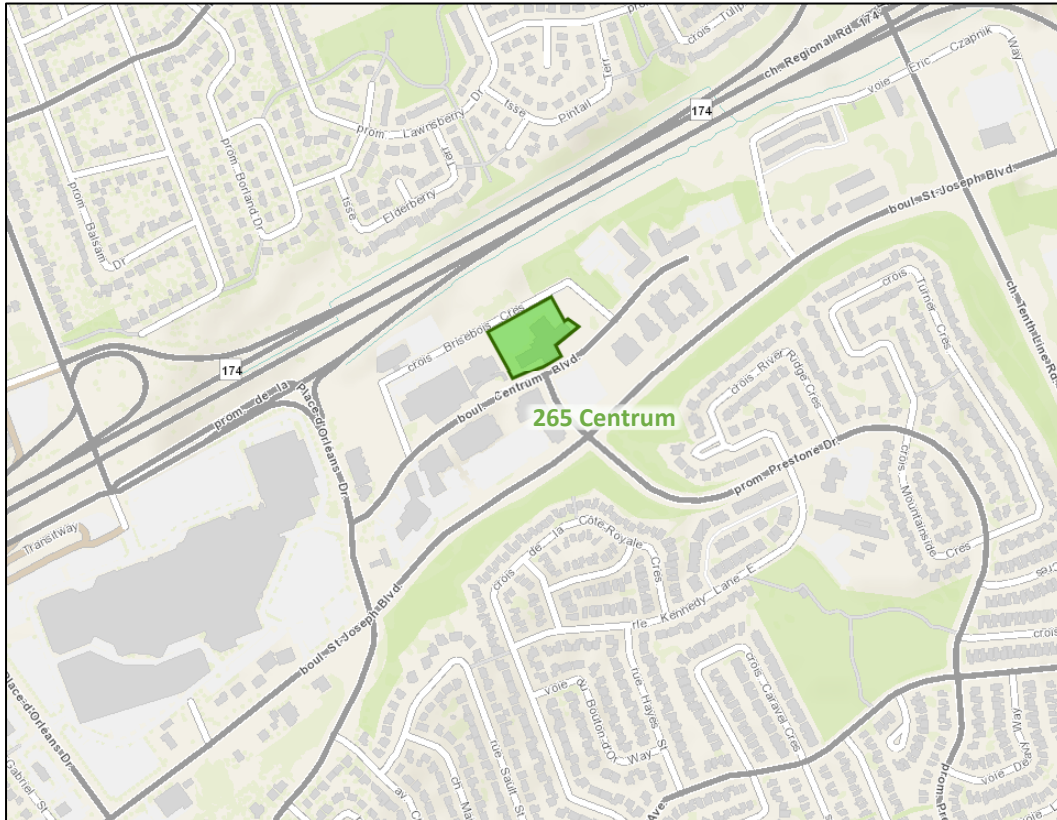

Source: <http://maps.ottawa.ca/geoOttawa/> Accessed: January 31, 2023

Figure 2: Concept Plan

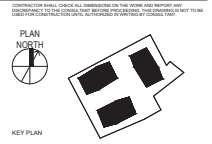
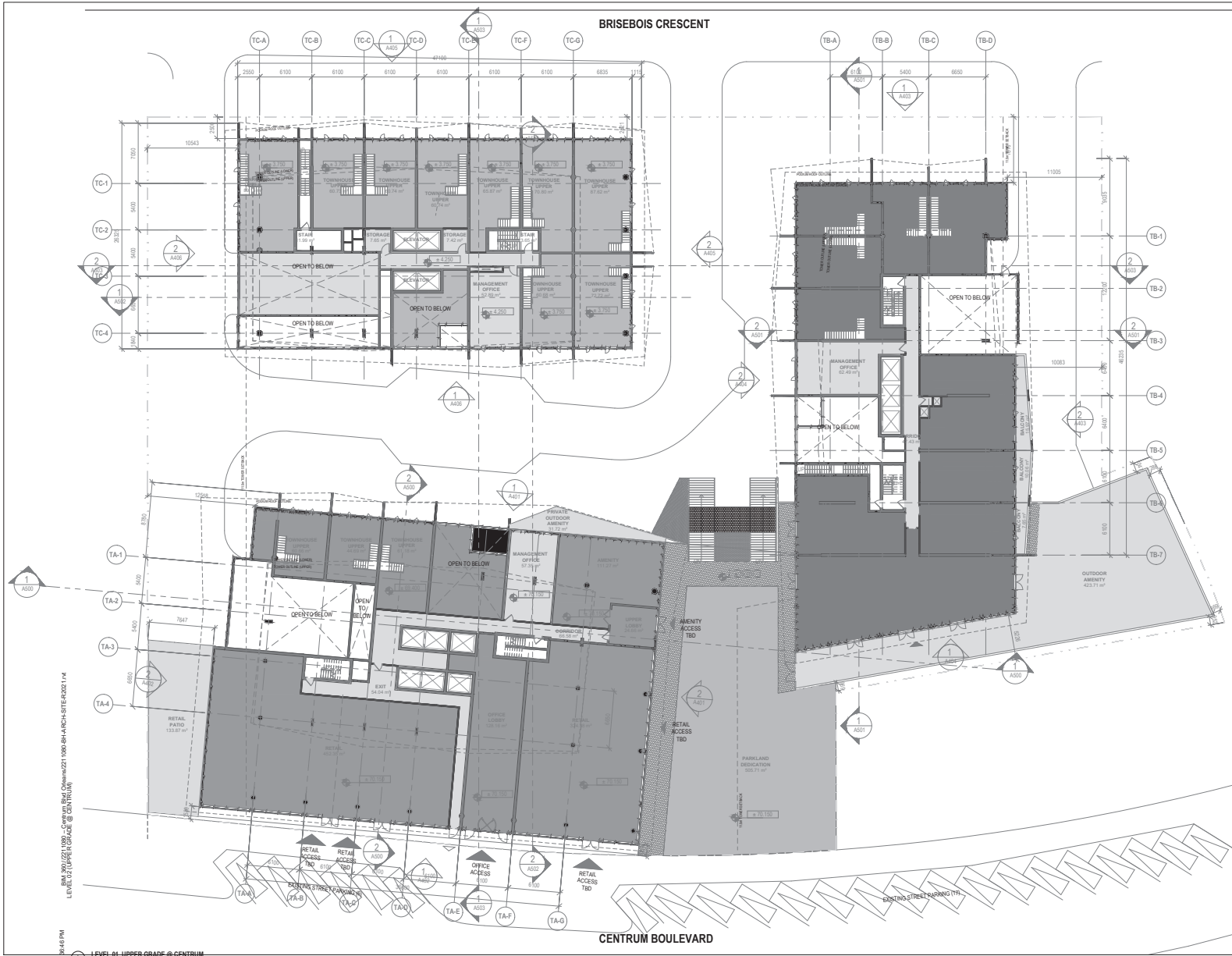

REVISION	
NO.	DESCRIPTION
01	ISSUED FOR SITE PLAN APPROVAL

B+H Architects
 230 Dufferin Street, Suite 200
 Toronto, ON M5H 4A8
 Tel: 416-598-2269 Fax: 416-598-0599

SEAL:

- STRUCTURAL ENGINEER
Art Engineering
 171 Spadina Ave.
 Carp. Reg. No. 110
 T18-5436-8802
- MECHANICAL ENGINEER
Mechanical Consultant
 Street Address:
 City, Post Code:
 T18-5436-8802
- ELECTRICAL ENGINEER
Electrical Consultant
 Street Address:
 City, Post Code:
 T18-5436-8802
- WIND ENGINEERING CONSULTANT
Gradient Wind
 127 Wagon Wheel Rd.
 Carp. Reg. No. 110
 T18-5436-8802
- LANDSCAPE ARCHITECT
J. Lennox and Associates
 3333 Leslie Ave.
 Niagara Falls, ON L2E 1S8
 T18-5436-8802
- SITE SERVICES/ENGINEER
McIntosh Perry
 110 Wagon Wheel Rd.
 Carp. Reg. No. 110
 T18-5436-8802
- PLANNING CONSULTANT
Fotens
 206 Conroy St. Suite 300
 Ottawa, ON K1P 2M5
 T18-5436-8802
- TRUCK CONSULTANT
CGH
 73 Matheson Ave.
 Niagara Falls, ON L2E 1S8
 T18-5436-8802

BAYVIEW GROUP
 108 Chestnut Street
 Toronto M5G 1R3
 Tel: 416-591-6988

PROJECT:
CENTRUM

265 CENTRUM BLVD
 ORLEANS, ON
 K1E 3K7

SHEET CONTENTS:
LEVEL 02 (UPPER GRADE @ CENTRUM)

PROJECT NUMBER:
2211080

DATE:
1 : 200

DRAWN BY: Author
 CHECKED BY: Checker
 DATE: 02/13/23

SHEET NO:
A204

REV:
1

3/2/2023 2:38:46 PM
 C:\Users\jgarcia\OneDrive\Documents\2211080-BH-ARCH-SITE-02021.dwg
 LEVEL 02 (UPPER GRADE @ CENTRUM)

2.2 Existing Conditions

2.2.1 Area Road Network

Place d'Orleans Drive: Place d'Orleans Drive is a City of Ottawa arterial road with a four-lane cross-section. The posted speed limit is 60km/h. Sidewalks are present on both sides of the road. The City-protected right of way is 37.5 metres within the study area. Place d'Orleans Drive is a designated truck route.

St Joseph Boulevard: St Joseph Boulevard is a City of Ottawa arterial road with a divided, four-lane cross-section. The posted speed limit is 50km/h west of Prestone Drive and 60km/h east of Prestone Drive. Sidewalks are present on both sides of the road. The City protected right-of-way is 32.0 metres from Gabriel Street to 130 m west of Duford Drive and 37.5 metres east to Trim Road. St Joseph Boulevard is a designated truck route.

Centrum Boulevard: Centrum Boulevard is a City of Ottawa collector road with a two-lane cross-section. The posted speed limit is 40km/h. Sidewalks and angle parking are provided on both sides of the road. The existing right of way is 26.0 metres within the study area.

Prestone Drive: Prestone Drive is a City of Ottawa collector road with a divided four-lane cross-section north of St Joseph Boulevard, and a major collector road south of St Joseph Boulevard with an undivided two-lane cross-section. The posted speed limit is 40km/h. Sidewalks are present on both sides of the road. Within the study area, the existing right of way is 24.5 metres north of St Joseph Boulevard and 26.0 metres south of St Joseph Boulevard.

Brisebois Crescent: Brisebois Crescent is a City of Ottawa local road with a two-lane cross-section. The unposted speed limit is assumed to be 50km/h. Sidewalks are present on one side of the road, and perpendicular parking is provided on the south side of the road. The existing right of way is 18.0 metres within the study area.

2.2.2 Existing Intersections

The existing key area intersections within 400 metres of the site have been summarized below:

<i>Centrum Boulevard at Place d'Orleans Drive</i>	The intersection of Centrum Boulevard at Place d'Orleans Drive is a signalized intersection. The northbound and southbound approaches each consist of a shared left-turn/through lane and a shared through/right-turn lane. The eastbound approach consists of an auxiliary left-turn lane, a through lane, and an auxiliary channelized right-turn lane, and the westbound approach consists of a left-turn lane and a shared through/channelized right-turn lane. No turn restrictions were noted.
<i>Centrum Boulevard at Brisebois Crescent West</i>	The intersection of Centrum Boulevard at Brisebois Crescent West is an unsignalized intersection with stop control on the minor approaches of Brisebois Crescent West. All approaches consist of a shared all-movements lane. No turn restrictions were noted.
<i>Centrum Boulevard at Prestone Drive</i>	The intersection of Centrum Boulevard at Prestone Drive is an unsignalized T-intersection with all-way stop control. The northbound approach consists of a left-turn lane and a right-turn lane. The eastbound approach consists of a shared through/right-turn lane, and the westbound approach consists of a shared left-turn/through lane. No turn restrictions were noted.
<i>Centrum Boulevard at Brisebois Crescent East</i>	The intersection of Centrum Boulevard at Brisebois Crescent East is an unsignalized T-intersection with stop control on the minor

approach of Brisebois Crescent East. All approaches consist of a shared all-movements lane. No turn restrictions were noted.

St Joseph Boulevard at Prestone Drive

The intersection of St Joseph Boulevard at Prestone Drive is a signalized intersection. The northbound approach consists of an auxiliary left-turn lane and a shared through/channelized right-turn lane, and the southbound approach consists of a left-turn lane and a shared through/channelized right-turn lane. The eastbound and westbound approaches each consist of an auxiliary left-turn lane, two through lanes, and an auxiliary channelized right-turn lane. No turn restrictions were noted.

2.2.3 Existing Driveways

Within 200 metres of the site accesses, three driveways to an office, three driveways to an art school, and one driveway to a library are on Brisebois Crescent. One driveway to a retail plaza, one to a parking lot, three to condominiums, and one to townhouses are present on Centrum Boulevard. On Prestone Drive, one driveway to a retail plaza and one to a parking lot are present. Figure 3 illustrates the existing driveways.

Figure 3: Existing Driveways

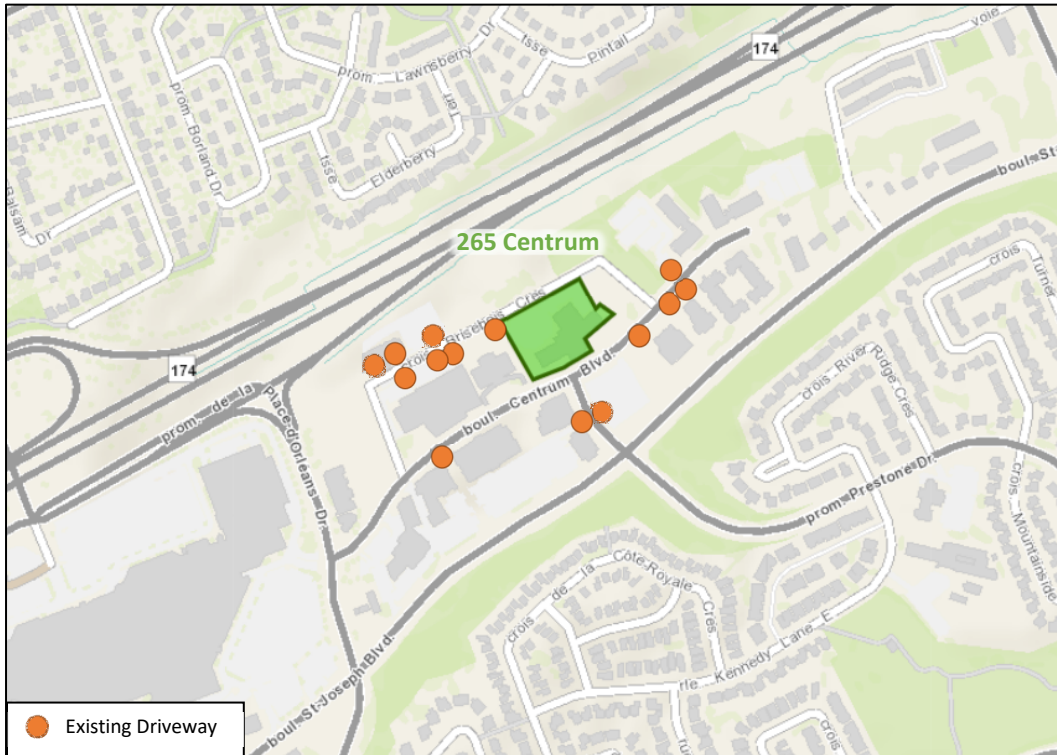

Source: <http://maps.ottawa.ca/geoOttawa/> Accessed: January 31, 2023

2.2.4 Cycling and Pedestrian Facilities

Figure 4 illustrates the pedestrian facilities in the study area and Figure 5 illustrates the cycling facilities.

Sidewalks are provided on both sides of Place d’Orleans Drive, St Joseph Boulevard, Centrum Boulevard, and Prestone Drive. Sidewalks are also provided on one side of Brisebois Crescent.

No existing cycling facility is within the study area. St Joseph Boulevard is a cross-town bikeway, and Place d’Orleans Drive and Prestone Drive south of St Joseph Boulevard are local routes.

Figure 4: Study Area Pedestrian Facilities

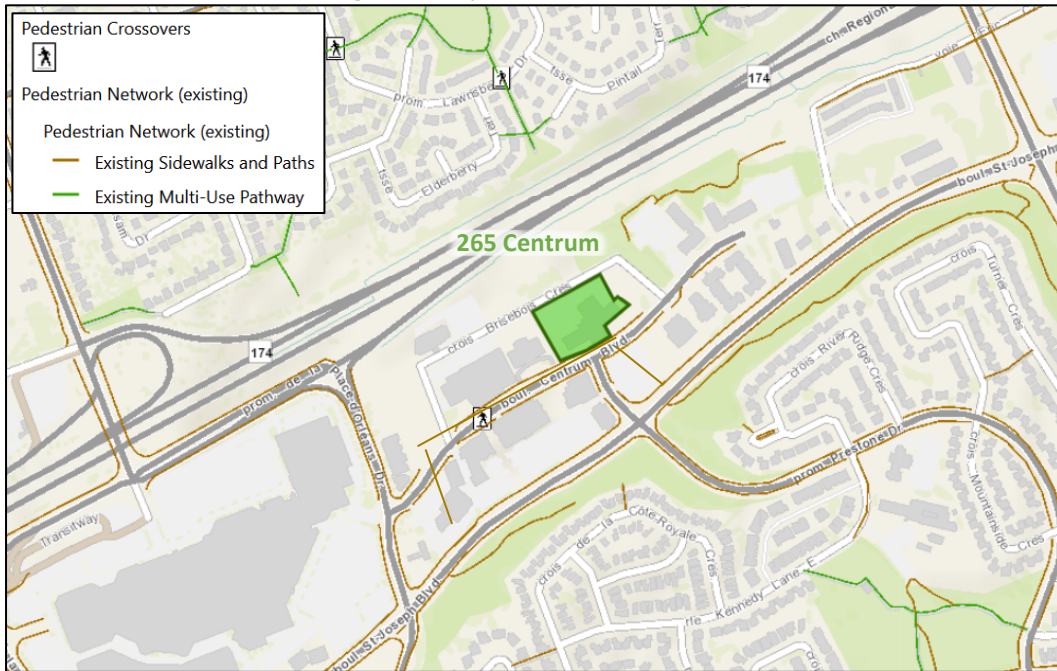

Source: <http://maps.ottawa.ca/geoOttawa/> Accessed: January 31, 2023

Figure 5: Study Area Cycling Facilities

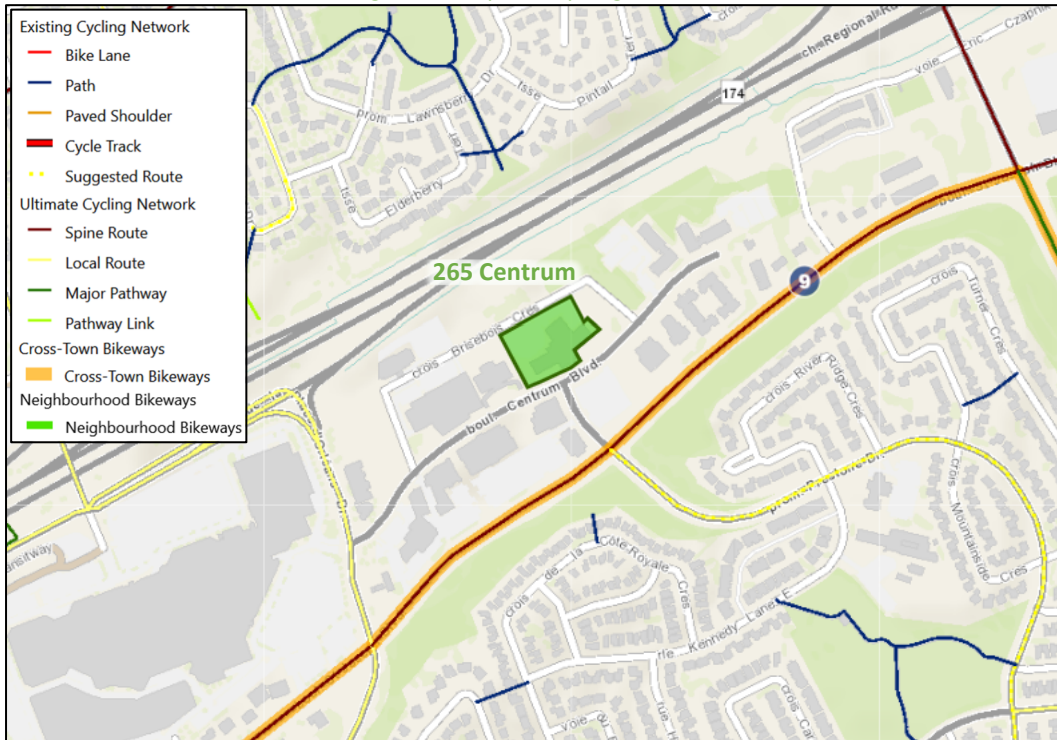

Source: <http://maps.ottawa.ca/geoOttawa/> Accessed: January 31, 2023

Pedestrian and cyclist volumes included in study area intersection counts, presented in Section 2.2.7, have been compiled and are illustrated in Figure 6 and Figure 7, respectively. The intersection of Centrum Boulevard at

Prestone Drive and Centrum Boulevard at Brisebois Crescent East do not have data available, and it will be collected.

Figure 6: Existing Pedestrian Volumes

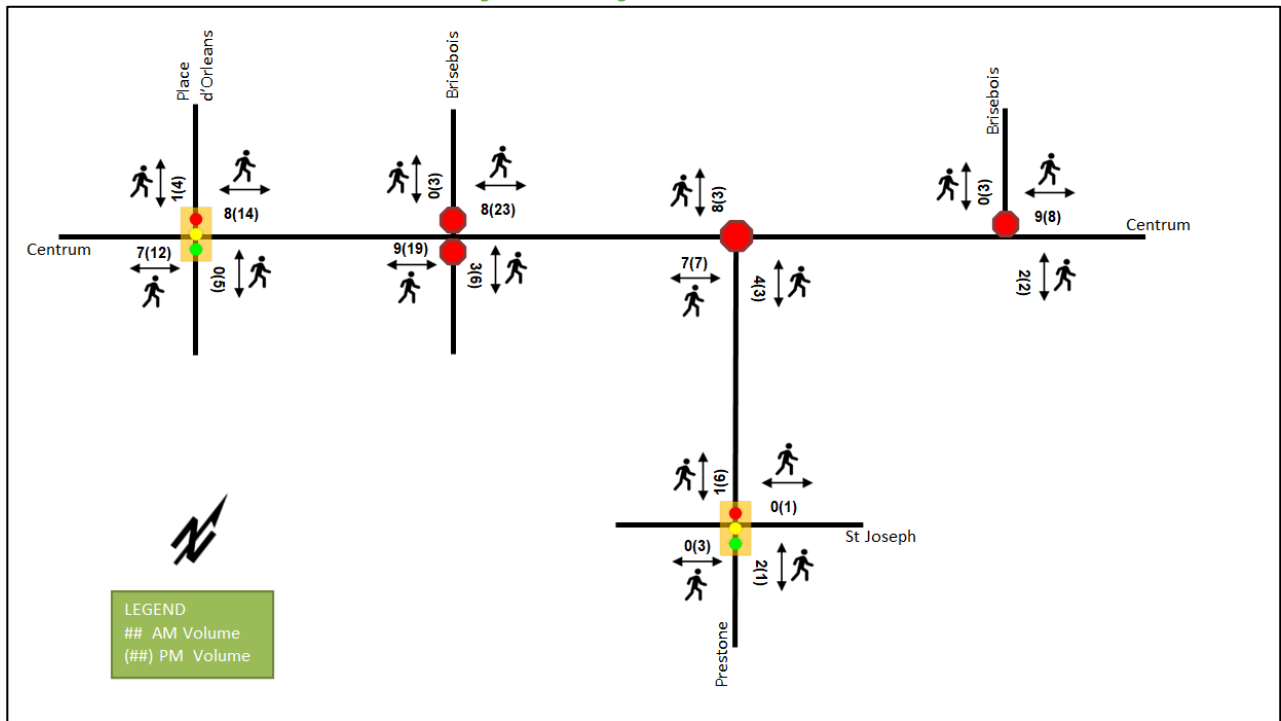
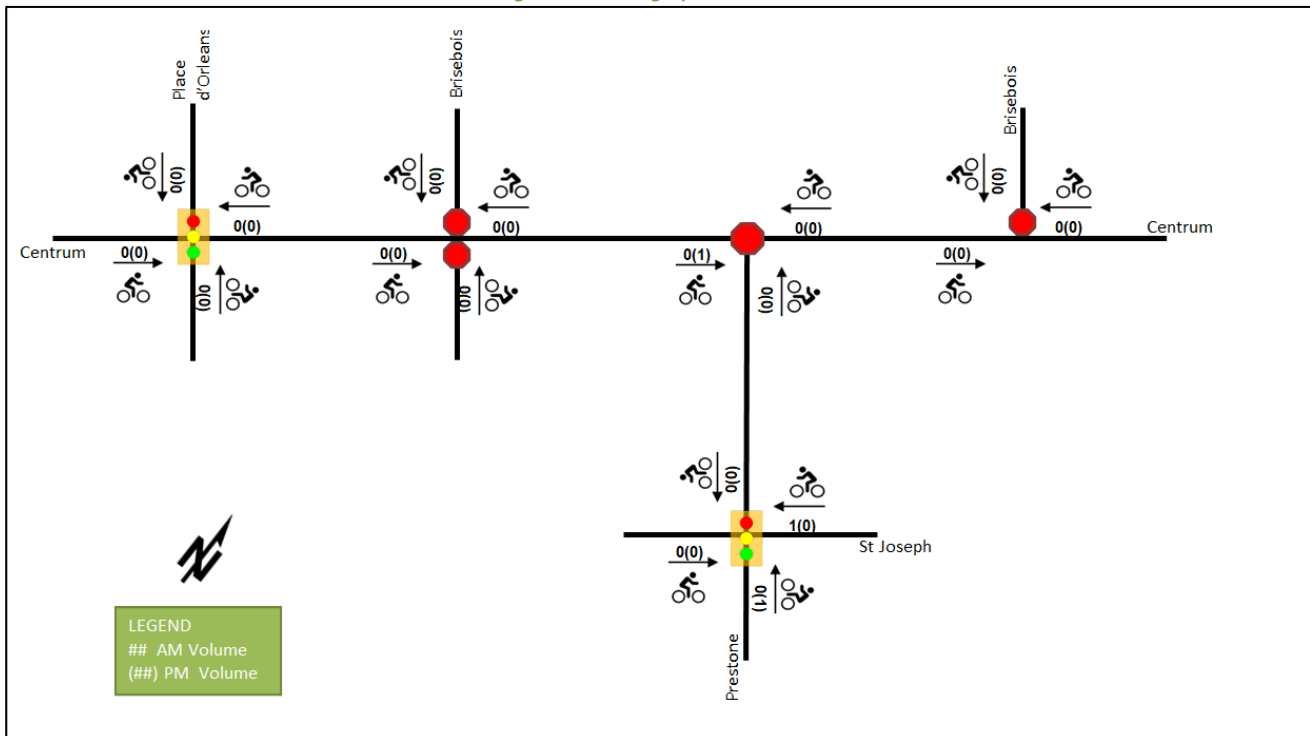

Figure 7: Existing Cyclist Volumes



2.2.5 Existing Transit

Figure 8 illustrates the transit system map in the study area and Figure 9 illustrates nearby transit stops and stations. All transit information is from January 31, 2023, and is included for general information purposes and context to the surrounding area.

Within the study area, routes #33, #35, #37, #232, and #302 travel along Centrum Boulevard and Prestone Drive, and routes #37, #131, and #234 travel along Place d’Orleans Drive. The frequency of these routes within proximity of the proposed site based on January 31, 2023 service levels are:

- Route # 33 – 30-minute service all day
- Route # 35 – 30-minute service all day
- Route # 37 – 30-minute service all day until 8:00 PM
- Route # 232 – 30-minute service in the peak period/direction
- Route # 302 – One bus in the peak period/direction
- Route # 131 – 30-minute service all day, 1-hr service after 9:00 PM
- Route # 234 – 30-minute service in the peak period/direction

Place d’Orléans station is located within 800 metres from the site. The bus station serves bus routes #33, #35, #37, #38, #39, #131, #221, #232, #234, #236, #302, #639, and #678.

Place d’Orléans station will be converted to accommodate LRT, and the future Place d’Orléans station is located within 800 metres from the site. The completion of the future Place d’Orléans station is anticipated by the end of 2024. Future Orleans Town Centre LRT is noted to be located within 400 metres from the site, however, the timeline is unknown.

Figure 8: Existing Study Area Transit Service

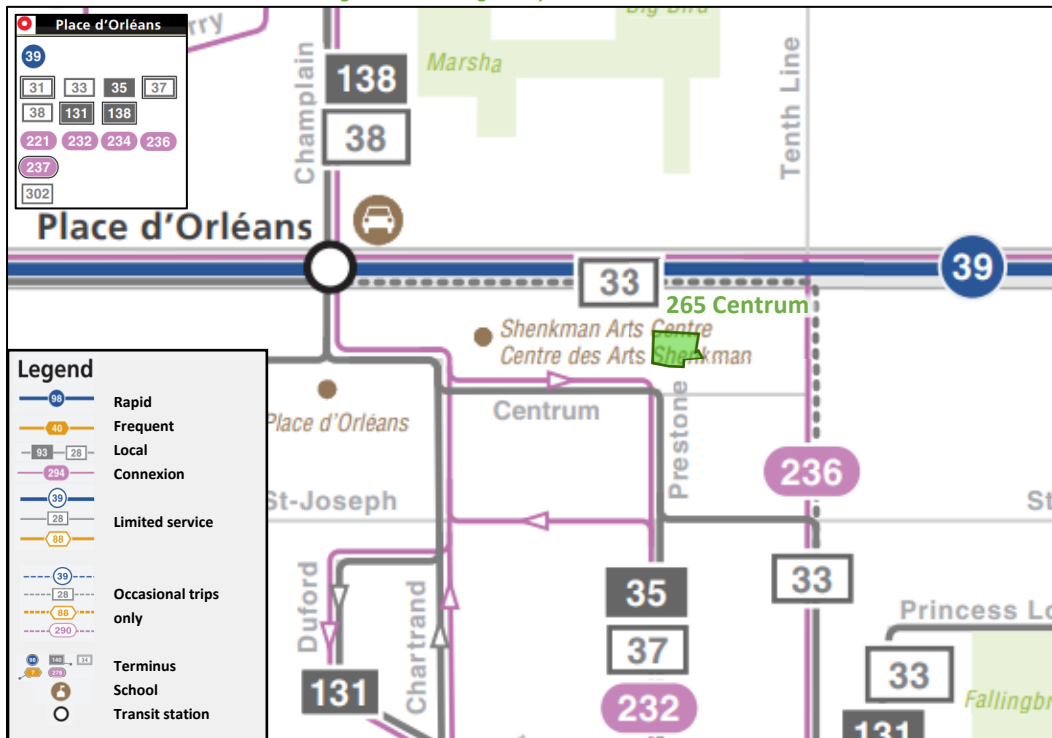

Source: <http://www.octranspo.com/> Accessed: January 31, 2023

Figure 9: Existing Study Area Transit Stops

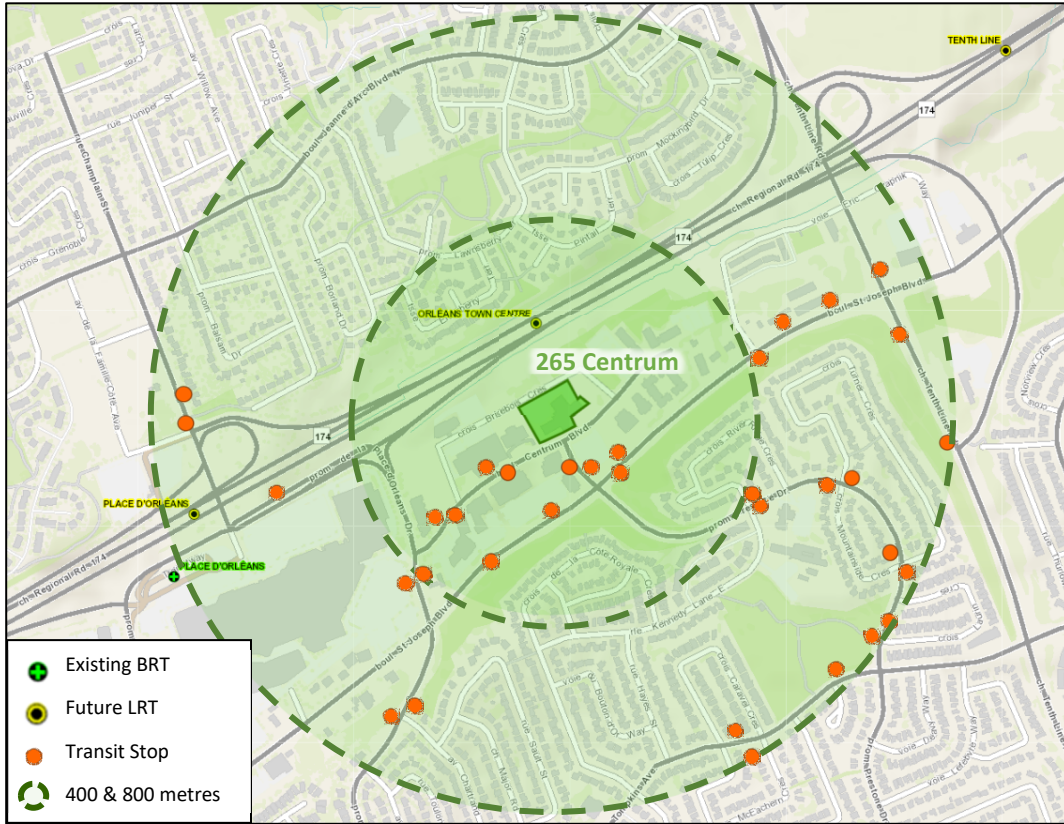

Source: <http://maps.ottawa.ca/geoOttawa/> Accessed: March 23, 2023

2.2.6 Existing Area Traffic Management Measures

An on-road messaging of maximum speed limit of 40 km/h is present on Prestone Drive.

2.2.7 Existing Peak Hour Travel Demand

Existing turning movement counts were acquired from the City of Ottawa and The Traffic Specialist for the existing study area key intersections. The intersection of Centrum Boulevard at Prestone Drive and Centrum Boulevard at Brisebois Crescent East do not have data available, and it will be collected. Table 1 summarizes the intersection count dates.

Table 1: Intersection Count Date

Intersection	Count Date	Source
Centrum Boulevard at Place d’Orleans Drive	Thursday, January 31, 2019	City of Ottawa
Centrum Boulevard at Brisebois Crescent West	Thursday, 12 March, 2020	The Traffic Specialist
Centrum Boulevard at Prestone Drive	Tuesday, February 14, 2023	The Traffic Specialist
Centrum Boulevard at Brisebois Crescent East	Wednesday, February 08, 2023	The Traffic Specialist
St Joseph Boulevard at Prestone Drive	Tuesday, March 20, 2018	City of Ottawa

Figure 10 illustrates the existing traffic counts and Table 2 summarizes the existing intersection operations. The level of service for signalized intersections is based on volume to capacity ratio (v/c) calculations for individual lane movements and HCM 2000 v/c calculations for the overall intersection, and average delay for unsignalized intersections. Detailed turning movement count data is included in Appendix B and the Synchro worksheets are provided in Appendix C.

Figure 10: Existing Traffic Counts

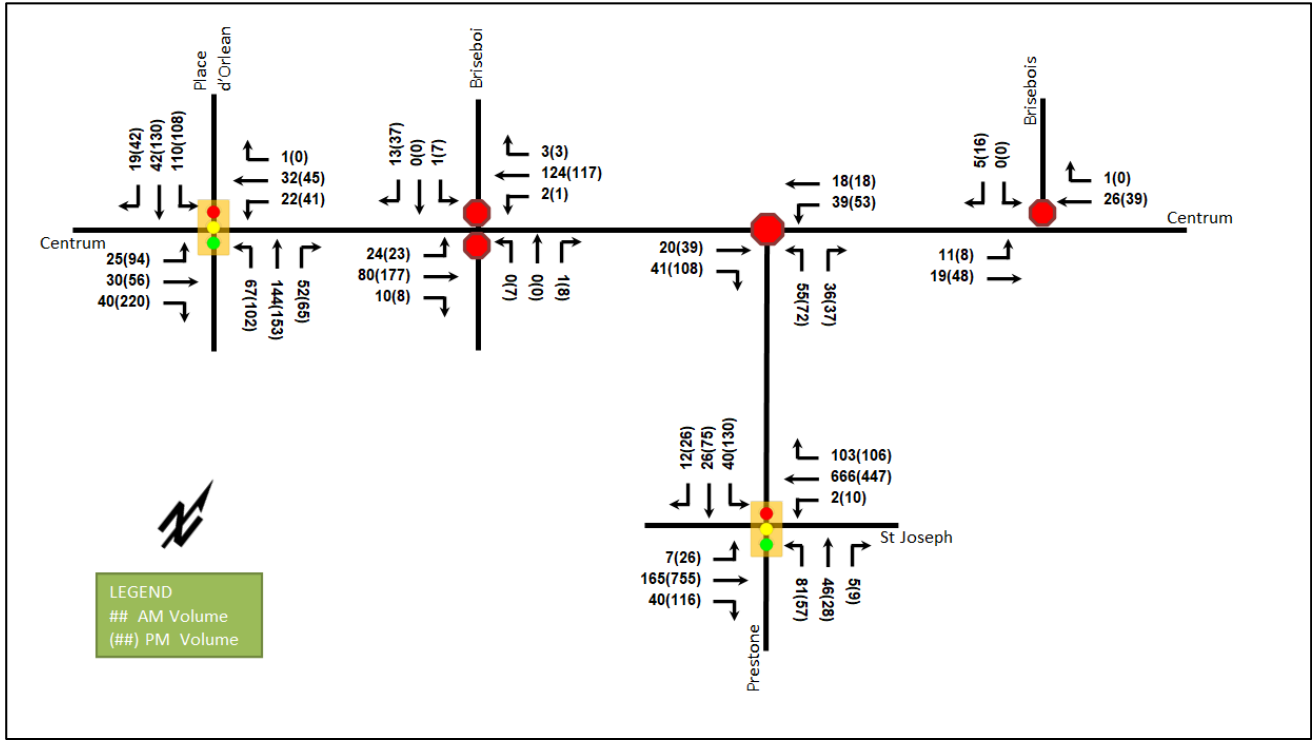

Table 2: Existing Intersection Operations

Intersection	Lane	AM Peak Hour				PM Peak Hour			
		LOS	V/C	Delay (s)	Q (95 th)	LOS	V/C	Delay (s)	Q (95 th)
Centrum Boulevard at Place d'Orleans Drive <i>Signalized</i>	EBL	A	0.11	20.2	7.8	A	0.49	38.4	25.9
	EBT	A	0.09	19.6	8.5	A	0.21	29.7	16.1
	EBR	A	0.14	7.6	6.1	A	0.54	8.5	15.7
	WBL	A	0.09	19.7	7.0	A	0.22	30.4	13.3
	WBT/R	A	0.11	19.4	9.1	A	0.17	28.9	13.8
	NB	A	0.14	4.8	15.3	A	0.22	5.2	18.7
	SB	A	0.12	5.4	11.6	A	0.20	5.4	17.4
	Overall	A	0.15	8.0	-	A	0.26	12.2	-
Centrum Boulevard at Brisebois Crescent West <i>Unsignalized</i>	EB	A	0.02	7.6	0.8	A	0.02	7.6	0.8
	WB	A	0.00	7.5	0.0	A	0.00	7.7	0.0
	NB	A	0.00	9.9	0.0	B	0.03	11.0	0.8
	SB	A	0.02	9.2	0.8	A	0.06	9.9	1.5
	Overall	A	-	1.3	-	A	-	2.0	-
Centrum Boulevard at Prestone Drive <i>Unsignalized</i>	EB	A	0.07	7.2	1.5	A	0.18	7.8	4.5
	WB	A	0.08	7.8	1.5	A	0.10	8.1	2.3
	NBL	A	0.09	8.7	2.3	A	0.13	9.3	3.0
	NBR	A	0.05	7.0	0.8	A	0.05	7.3	1.5
	Overall	A	-	7.7	-	A	-	8.1	-
Centrum Boulevard at Brisebois Crescent East <i>Unsignalized</i>	EB	A	0.01	7.4	0.0	A	0.01	7.3	0.0
	WB	-	-	-	-	-	-	-	-
	SB	A	0.01	8.6	0.0	A	0.02	8.6	0.8
	Overall	A	-	2.0	-	A	-	1.7	-

Intersection	Lane	AM Peak Hour				PM Peak Hour			
		LOS	V/C	Delay (s)	Q (95 th)	LOS	V/C	Delay (s)	Q (95 th)
St Joseph Boulevard at Prestone Drive Signalized	EBL	A	0.05	11.9	2.6	A	0.05	6.7	5.3
	EBT	A	0.17	12.2	11.3	A	0.39	7.5	48.6
	EBR	A	0.09	4.7	4.7	A	0.13	1.9	6.5
	WBL	A	0.01	11.0	1.1	A	0.03	6.9	2.8
	WBT	B	0.67	18.0	44.4	A	0.23	6.4	26.7
	WBR	A	0.21	3.9	7.4	A	0.12	1.9	6.2
	NBL	A	0.16	11.3	14.1	A	0.28	26.7	16.5
	NBT/R	A	0.08	9.6	9.0	A	0.13	19.2	10.4
	SBL	A	0.08	10.7	8.2	A	0.59	36.1	33.2
	SBT/R	A	0.07	8.3	6.8	A	0.35	22.2	22.5
Overall	A	0.38	14.1	-	A	0.43	10.3	-	

Notes: Saturation flow rate of 1800 veh/h/lane
Queue is measured in metres
Peak Hour Factor = 0.90

Delay = average vehicle delay in seconds
m = metered queue
= volume for the 95th %ile cycle exceeds capacity

During both the AM and PM peak hours, the study area intersections operate well. No capacity issues are noted.

2.2.8 Collision Analysis

Collision data have been acquired from the City of Ottawa open data website (data.ottawa.ca) for five years prior to the commencement of this TIA for the surrounding study area road network. Table 3 summarizes the collision types and conditions in the study area, Figure 11 illustrates the intersections and segments analyzed, and Table 4 summarizes the total collisions for each of these locations. Collision data are included in Appendix D.

Table 3: Study Area Collision Summary, 2016-2020

		Number	%
Total Collisions		32	100%
Classification	Fatality	0	0%
	Non-Fatal Injury	8	25%
	Property Damage Only	24	75%
Initial Impact Type	Approaching	1	3%
	Angle	13	41%
	Rear end	4	13%
	Sideswipe	2	6%
	Turning Movement	6	19%
	SMV Other	6	19%
Road Surface Condition	Dry	21	66%
	Wet	3	9%
	Loose Snow	6	19%
	Packed Snow	2	6%
Pedestrian Involved		3	9%
Cyclists Involved		0	0%

Figure 11: Study Area Collision Records

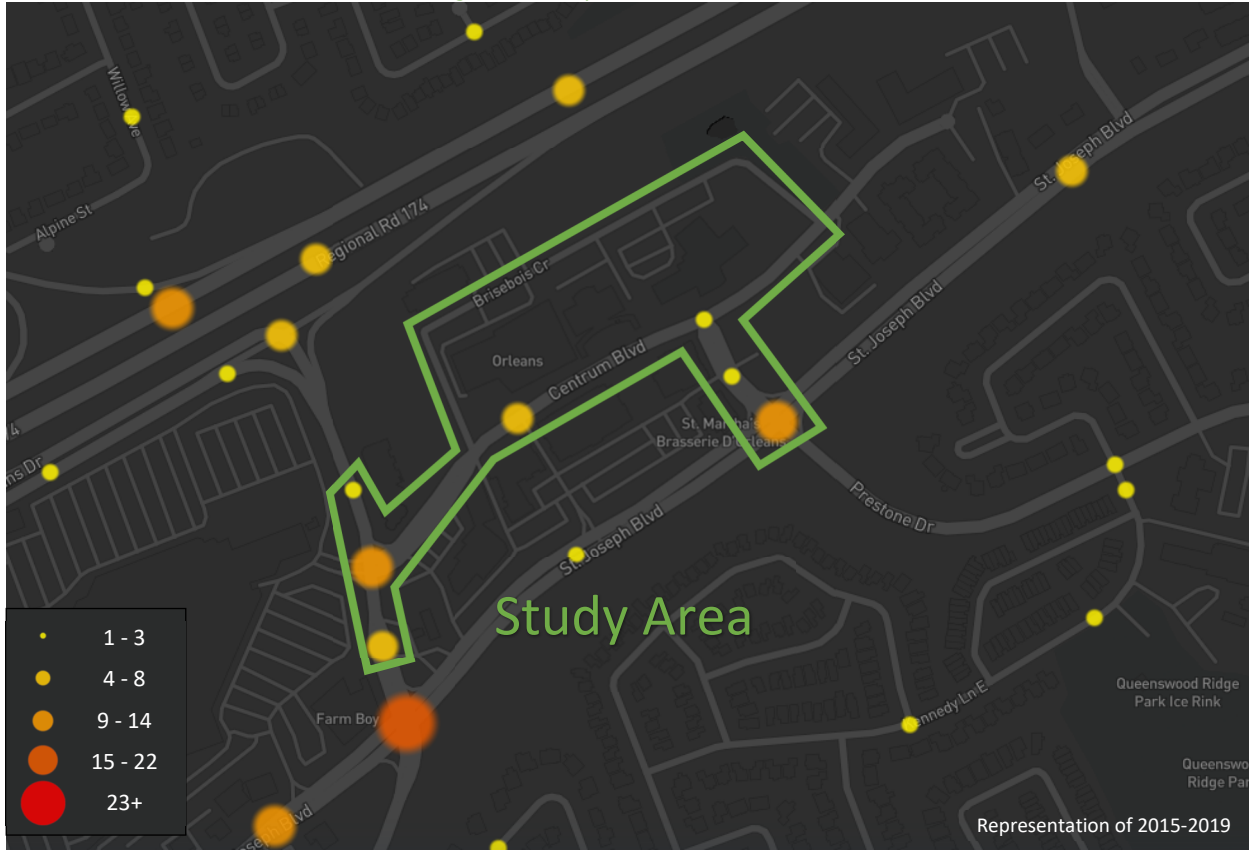

Table 4: Summary of Collision Locations, 2016-2020

Intersections / Segments	Number	%
Intersections / Segments	32	100%
St. Joseph Blvd @ Prestone Dr	11	34%
Place D'orleans Dr btwn Centrum Blvd & St. Joseph Blvd	7	22%
Place D'orleans @ Centrum Blvd/Place D'orleans	6	19%
Centrum Blvd btwn Place D'orleans Dr & Prestone Dr	5	16%
Centrum Blvd @ Prestone Dr	2	6%
Place D'orleans Dr btwn Turn Lane & Centrum Blvd	1	3%

Within the study area, the intersection of St Joseph Boulevard at Prestone Drive is noted to have experienced higher collisions than other locations. Table 5 summarizes the collision types and conditions for the location.

Table 5: St Joseph Boulevard at Prestone Drive Collision Summary

		Number	%
Total Collisions		11	100%
Classification	Fatality	0	0%
	Non-Fatal Injury	4	36%
	Property Damage Only	7	64%
Initial Impact Type	Angle	4	36%
	Rear end	2	18%
	Turning Movement	3	27%
	SMV Other	2	18%
Road Surface Condition	Dry	7	64%
	Wet	2	18%
	Loose Snow	2	18%
Pedestrian Involved		1	9%
Cyclists Involved		0	0%

The St Joseph Boulevard at Prestone Drive intersection had a total of eleven collisions during the 2016-2020 time period, with seven involving property damage only and the remaining four having non-fatal injuries. The collision types are most represented by angle with four collisions, followed by three turning movement collisions, and the remaining collisions split between the rear end and SMV (other). The majority of the collisions (7 of 11) occurred during 2017 and 2018 when there was resurfacing operations occurred through the intersection, which is assumed to be the cause of the elevated collision rate during these two years. Weather conditions do not affect collisions at this location. No further examination is required as part of this study.

2.3 Planned Conditions

2.3.1 Changes to the Area Transportation Network

Within the Official Plan, the ultimate transit network diagram shows the O-train along Regional Road 174, with a station located at Place d'Orleans connecting to the existing park and ride/station, and a future station north of the site, currently called 'Orleans Town Centre'. This station is unfunded and will not be considered within this study.

Place d'Orleans station, which is located approximately 800 metres from the site, is identified as one of the east extension stations in the Stage 2 Light Rail Transit (LRT) project and will be converted to accommodate LRT. The completion of the east extension is anticipated by the end of 2024.

The extension of Centrum Boulevard to Vieux Silo Street has been identified in the Orleans Corridor Secondary Plan. No property has been acquired and will not be included within this study.

2.3.2 Other Study Area Developments

280 Eric Czapnik Way

The proposed development application includes a site plan application to include two apartment buildings for a total of 72 dwellings. No TIA is expected to be warranted for this development.

3277 St Joseph Boulevard

The proposed development application includes a site plan application to include two apartment buildings for a total of 274 dwellings. The development is predicted to generate 58 new AM and 60 new PM two-way peak-hour auto trips. The anticipated build-out horizon is 2024. (Novatech, 2021)

3459 & 3479 St Joseph Boulevard

The proposed development application includes a zoning by-law amendment to allow 326 apartment units. The development is predicted to generate 141 new AM and 179 new PM two-way peak-hour auto trips. The build-out horizon is assumed to be 2023. (Novatech, 2021)

360 Kennedy Lane East

The proposed development application includes a zoning by-law amendment and site plan application to include 81 residential dwelling units. No TIA is expected to be warranted for this development.

3 Study Area and Periods

3.1 Study Area

The study area will include the intersections of:

- Centrum Boulevard at:
 - Place d’Orleans Drive
 - Brisebois Crescent West
 - Prestone Drive
 - Brisebois Crescent East
- St Joseph Boulevard at:
 - Prestone Drive

The boundary road will be Brisebois Crescent and Centrum Boulevard, and the SL-45 screenline is located to the west of the Place d’Orleans Mall. The screenline will not be assessed as part of this study.

While within 1 km of the site, other development sites in the area have excluded the intersections along Place d’Orleans Drive at Champlain Street and the Place d’Orleans at Highway 174 offramp. The Place d’Orleans Drive and Highway 174 on-ramp intersection has been reviewed in other area studies and operates well during existing conditions and future projections. This is similar to the existing conditions intersections examined within Section 2.2.7. Therefore, these intersections have been excluded from the scope of this study going forward. If undue impacts are noted at the intersections in proximity to the site, such as Place d’Orleans Drive or Prestone Drive at St Laurent Boulevard, these intersections may be re-incorporated into the study.

3.2 Time Periods

As the proposed development is composed mainly of residential units, the AM and PM peak hours will be examined.

3.3 Horizon Years

The anticipated build-out year is 2028. As a result, the full build-out plus five years horizon year is 2033.

4 Exemption Review

Table 6 summarizes the exemptions for this TIA.

Table 6: Exemption Review

Module	Element	Explanation	Exempt/Required
Design Review Component			
4.1 Development Design	4.1.2 Circulation and Access	Only required for site plans	Required
	4.1.3 New Street Networks	Only required for plans of subdivision	Exempt
4.2 Parking	4.2.1 Parking Supply	Only required for site plans	Required
	4.2.2 Spillover Parking	Only required for site plans where parking supply is 15% below unconstrained demand	Exempt
Network Impact Component			
4.5 Transportation Demand Management	All Elements	Not required for site plans expected to have fewer than 60 employees and/or students on location at any given time	Required
4.6 Neighbourhood Traffic Management	4.6.1 Adjacent Neighbourhoods	Only required when the development relies on local or collector streets for access and total volumes exceed ATM capacity thresholds	Required
4.8 Network Concept		Only required when proposed development generates more than 200 person-trips during the peak hour in excess of equivalent volume permitted by established zoning	Required

4.1 TIA Stepped Process

The removal of the existing YMCA site, and transit-oriented design of the subject site confirmed by the City of Ottawa during the pre-consultation meeting and notes, the expected increase in area trips will be much lower than a typical site on redevelopment land. No operational constraints are noted at the area intersections for the existing conditions, all movements at LOS A or B. Due to the above factors, future Steps 3 and 4 are combined into a single submission.

5 Development-Generated Travel Demand

5.1 Mode Shares

Examining the mode shares recommended in the TRANS Trip Generation Manual (2020) for the subject district, derived from the most recent National Capital Region Origin-Destination survey (OD Survey), the existing average district mode shares by land use for Orleans have been summarized in Table 7.

Table 7: TRANS Trip Generation Manual Recommended Mode Shares – Orleans

Travel Mode	Multi-Unit (High-Rise)		Commercial Generator		Employment Generator
	AM	PM	AM	PM	AM and PM
Auto Driver	54%	61%	77%	71%	71%
Auto Passenger	7%	13%	14%	20%	7%
Transit	29%	21%	3%	2%	13%
Cycling	0%	0%	0%	1%	1%
Walking	10%	6%	6%	5%	8%
Total	100%	100%	100%	100%	100%

It is noted that the future Place d’Orleans LRT station will be located approximately 800 metres from the site, and completion is anticipated by the end of 2024. In addition, transit-oriented design of the subject site is confirmed by the City of Ottawa during the pre-consultation meeting and notes. A 15% shift to transit mode from the auto mode for residential land use and a 10% percent shift to transit mode from the auto mode for commercial and office land use are proposed. The modified mode share targets are summarized in Table 8.

Table 8: Proposed Development Mode Shares

Travel Mode	Multi-Unit (High-Rise)		Commercial Generator		Employment Generator
	AM	PM	AM	PM	AM and PM
Auto Driver	39%	46%	67%	61%	61%
Auto Passenger	7%	13%	14%	20%	7%
Transit	44%	36%	13%	12%	23%
Cycling	0%	0%	0%	1%	1%
Walking	10%	6%	6%	5%	8%
Total	100%	100%	100%	100%	100%

5.2 Trip Generation

This TIA has been prepared using the vehicle and person trip rates for the residential dwellings using the TRANS Trip Generation Manual (2020) and the vehicle trip rates and derived person trip rates for commercial components from the ITE Trip Generation Manual 11th Edition (2021) using the City-prescribed conversion factor of 1.28. Table 9 summarizes the person trip rates for the proposed residential land uses for each peak period and the person trip rates for the non-residential land uses by peak hour.

Table 9: Trip Generation Person Trip Rates

Land Use	Land Use Code	Peak	Peak Period		Peak Hour	
			Vehicle Trip Rate	Person Trip Rates	Vehicle Trip Rate	Person Trip Rates
Multi-Unit (High-Rise)	221 & 222 (TRANS)	AM	-	0.80	-	-
		PM	-	0.90	-	-
General Office Building	710 (ITE)	AM	-	-	1.52	1.95
		PM	-	-	1.44	1.84
Strip Retail Plaza (<40k)	822 (ITE)	AM	-	-	2.36	3.02
		PM	-	-	6.59	8.44

Using the above person trip rates, the total person trip generation has been estimated. Table 10 summarizes the total person trip generation for the residential land uses and for the non-residential land uses.

Table 10: Total Person Trip Generation

Land Use	Units	AM Peak Period			PM Peak Period		
		In	Out	Total	In	Out	Total
Multi-Unit (High-Rise)	1,127	280	622	902	588	426	1014
Land Use	Units / GFA	AM Peak Hour			PM Peak Hour		
		In	Out	Total	In	Out	Total
General Office Building	31,570 sq. ft	55	7	62	10	48	58
Strip Retail Plaza (<40k)	8,970 sq. ft	16	10	26	37	39	76

Internal capture rates from the ITE Trip Generation Handbook 3rd Edition have been assigned to the development’s retail and office components for mixed-use developments. The rates summarized in Table 11 represent the percentage of trips to/from retail and office use based on the residential component.

Table 11: Internal Capture Rates

Land Use	AM		PM	
	In	Out	In	Out
Residential to/from Shopping Centre	17%	14%	10%	26%
Residential to/from Office	3%	1%	57%	2%

Pass-by reductions applied to the retail trip generation at a rate of 40% have been included using the recommended value presented in the ITE Trip Generation Manual 11th Edition (2021) for the most similar land use with a recommended rate, “Retail (40k – 150k sq. ft.)”.

Using the above mode share targets for the LRT area, the internal capture and pass-by rates, and the person trip rates, the person trips by mode have been projected. Trip generation by peak hour has been forecasted using the prescribed peak period conversion factors presented in the TRANS Trip Generation Manual (2020) for the residential component. Table 12 summarizes the residential trip generation and the non-residential trip generation by mode and peak hour.

Table 12: Trip Generation by Mode

Travel Mode		AM Peak Hour				PM Peak Hour			
		Mode Share	In	Out	Total	Mode Share	In	Out	Total
Multi-Unit (High-Rise)	Auto Driver	39%	52	117	169	46%	119	86	205
	Auto Passenger	7%	10	21	31	13%	33	24	58
	Transit	44%	68	151	219	36%	100	72	172
	Cycling	0%	0	0	0	0%	0	0	0
	Walking	10%	16	36	52	6%	18	14	32
	Total	100%	146	325	471	100%	270	196	466
General Office Building	Auto Driver	61%	32	4	36	61%	2	29	31
	Auto Passenger	7%	4	0	4	7%	0	3	3
	Transit	23%	12	2	14	23%	1	11	12
	Cycling	1%	1	0	1	1%	0	0	0
	Walking	8%	4	1	5	8%	0	4	4
	Internal Capture	varies	-2	0	-2	varies	-6	-1	-7
	Total	100%	53	7	60	100%	3	47	50

Travel Mode		AM Peak Hour				PM Peak Hour			
		Mode Share	In	Out	Total	Mode Share	In	Out	Total
Strip Retail Plaza (<40k)	Auto Driver	67%	3	2	5	61%	7	5	12
	Auto Passenger	14%	2	1	3	20%	7	7	14
	Transit	13%	2	1	3	12%	4	4	8
	Cycling	0%	0	0	0	1%	0	0	0
	Walking	6%	1	1	2	5%	2	2	4
	Internal Capture	varies	-2	-1	-3	varies	-2	-6	-8
	Pass-by	40%	-6	-4	-10	40%	-15	-16	-31
	Total	100%	8	5	13	100%	20	18	38
Total	Auto Driver	-	87	123	210	-	128	120	248
	Auto Passenger	-	16	22	38	-	40	34	74
	Transit	-	82	154	236	-	105	87	192
	Cycling	-	1	0	1	-	0	0	0
	Walking	-	21	38	59	-	20	20	40
	Internal Capture	varies	-4	-1	-5	varies	-8	-7	-15
	Pass-by	varies	-6	-4	-10	varies	-15	-16	-31
	Total	100%	207	337	544	100%	293	261	554

As shown above, a total of 210 AM and 248 PM new peak hour two-way vehicle trips are projected as a result of the proposed development.

5.3 Trip Distribution

To understand the travel patterns of the subject development, the OD Survey has been reviewed to determine the travel for the residential component, and these patterns were applied based on the build-out of Orleans Table 13 below summarizes the distributions.

Table 13: OD Survey Distribution – Orleans

To/From	Residential % of Trips
North	5%
South	30%
East	25%
West	40%
Total	100%

5.4 Trip Assignment

Using the distribution outlined above, turning movement splits, and access to major transportation infrastructure, the trips generated by the site have been assigned to the study area road network. Table 14 summarizes the proportional assignment to the study area roadways. Figure 12 illustrates the new site-generated volumes, and Figure 13 illustrates the pass-by volumes.

Table 14: Trip Assignment

To/From	Via
North	3% St Joseph (E) 2% Place d’Orleans (N)
South	20% Prestone Drive (S) 10% Place d’Orleans (S)
East	25% St Joseph (E)
West	40% St Joseph (W)
Total	100%

Figure 12: New Site Generation Auto Volumes

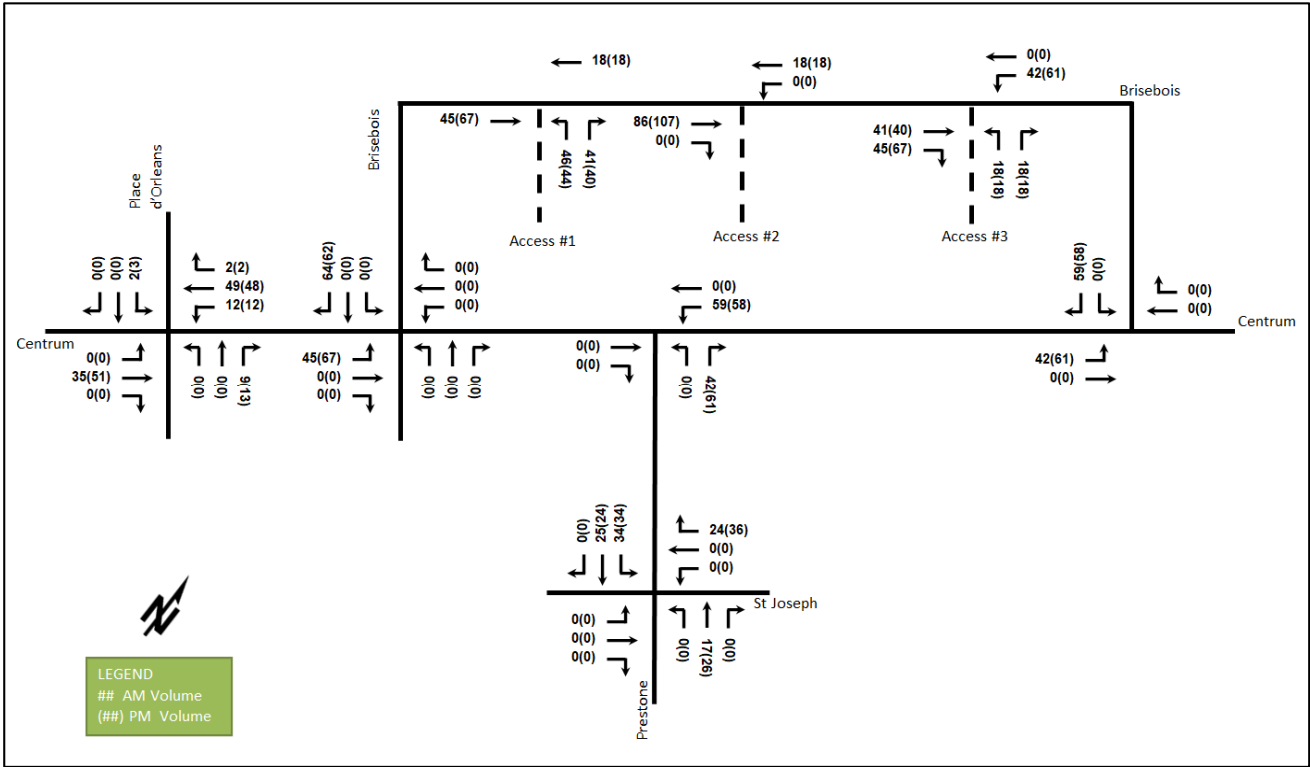
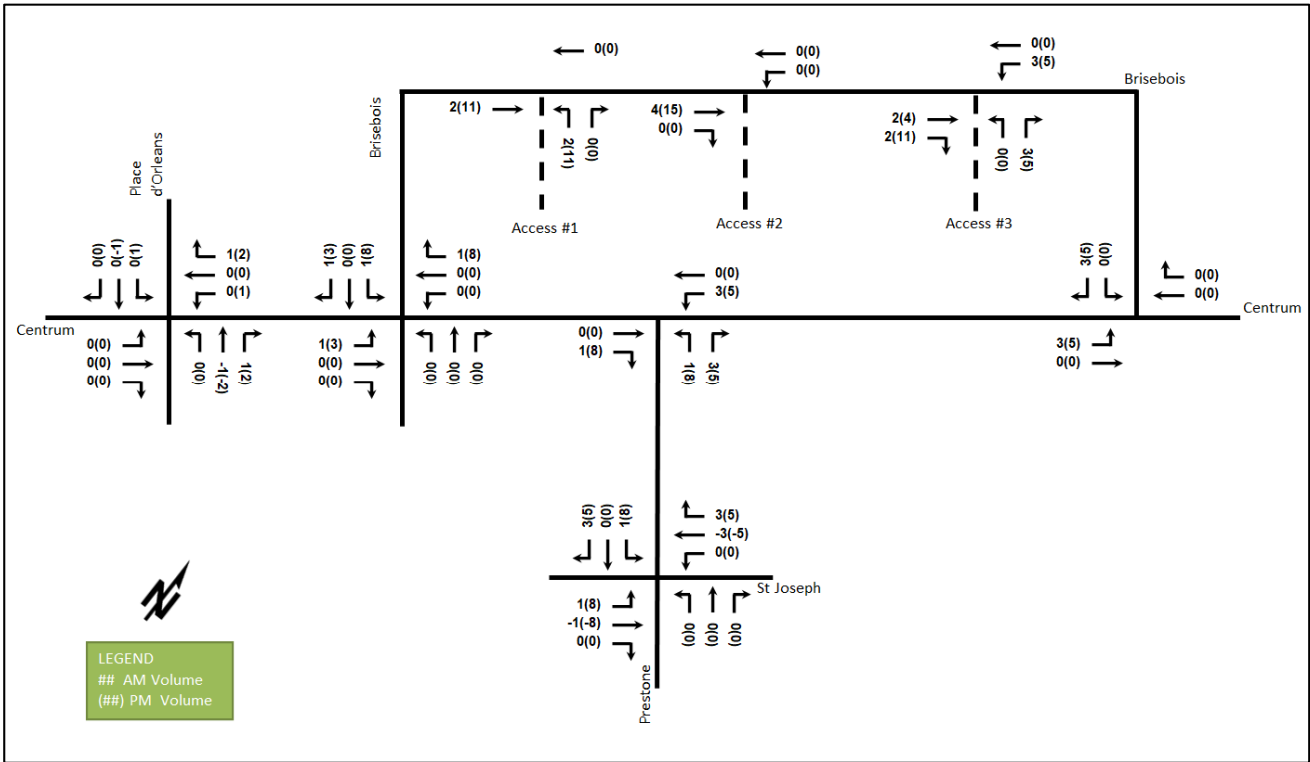

Figure 13: Pass-by Auto Volumes



6 Background Network Travel Demands

6.1 Transportation Network Plans

The transportation network plans were discussed in Section 2.3. The Place d’Orleans station Light Rail Transit (LRT) project is the only confirmed project within the study horizons and has been included.

6.2 Background Growth

A review of the background projections from the City’s TRANS Regional Model for the 2011 and 2031 horizons was completed to determine the background growth for each of the study area roadways. The background TRANS model growth rates are summarized in Table 15 and the TRANS model plots are provided in Appendix E.

Table 15: TRANS Regional Model Projections – Study Area Growth Rates

Street	TRANS Rate		2011 to Existing		Existing to 2031	
	Eastbound	Westbound	Eastbound	Westbound	Eastbound	Westbound
Centrum Blvd	0.21%	0.34%	7.74%	-6.68%	-10.10%	11.89%
St Joseph Blvd	0.17%	3.06%	7.71%	3.27%	-10.17%	2.74%
	Northbound	Southbound	Northbound	Southbound	Northbound	Southbound
Prestone Dr	-0.46%	-0.53%	-8.12%	0.97%	12.25%	-2.73%
Place d’Orleans Dr	3.71%	-0.24%	4.08%	23.91%	3.15%	-27.94%

A comparison of the TRANS volumes and the existing volumes, the eastbound movement along Centrum Boulevard and the southbound moment along Place d’Orleans Drive were underestimated and development has not progressed linearly. Table 16 summarizes the recommended growth rates to be considered within the study area.

Table 16: Recommended Area Growth Rates

Street	AM Peak Hour		PM Peak Hour	
	Eastbound	Westbound	Eastbound	Westbound
Centrum Blvd	0.25%	0.25%	0.25%	0.25%
St Joseph Blvd	0.25%	2.00%	2.00%	0.25%
	Northbound	Southbound	Northbound	Southbound
Prestone Dr	-	-	-	-
Place d’Orleans Dr	2.00%	-	-	2.00%

6.3 Other Developments

The background developments explicitly considered in the background conditions (Section 6.2) include:

- 3277 St Joseph Boulevard
- 3459 & 3479 St Joseph Boulevard

The background development volumes within the study area have been provided in Appendix F.

7 Demand Rationalization

7.1 2028 Future Background Operations

Figure 14 illustrates the 2028 background volumes and Table 17 summarizes the 2028 background intersection operations. The level of service for signalized intersections is based on v/c calculations for individual lane movements and HCM 2000 v/c calculations for the overall intersection, and average delay for unsignalized intersections. The synchro worksheets for the 2028 future background horizon are provided in Appendix G.

Figure 14: 2028 Future Background Volumes

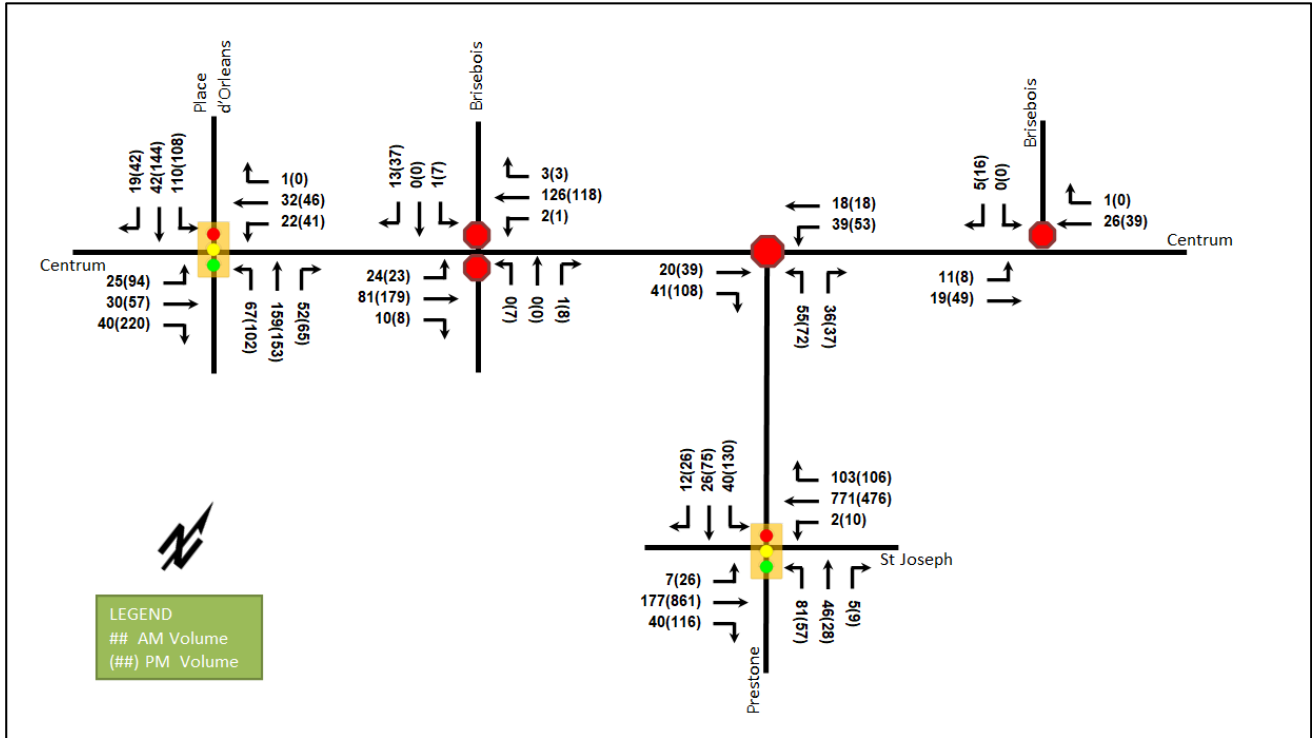

Table 17: 2028 Future Background Intersection Operations

Intersection	Lane	AM Peak Hour				PM Peak Hour			
		LOS	V/C	Delay (s)	Q (95 th)	LOS	V/C	Delay (s)	Q (95 th)
Centrum Boulevard at Place d'Orleans Drive <i>Signalized</i>	EBL	A	0.10	20.0	7.2	A	0.45	37.3	23.7
	EBT	A	0.08	19.5	8.0	A	0.20	29.7	15.2
	EBR	A	0.13	7.0	5.5	A	0.52	8.6	15.1
	WBL	A	0.08	19.6	6.5	A	0.20	30.2	12.3
	WBT/R	A	0.09	19.2	8.4	A	0.16	29.0	13.0
	NB	A	0.14	4.8	14.7	A	0.19	4.9	16.6
	SB	A	0.10	5.4	10.6	A	0.18	5.2	16.4
	Overall	A	0.14	7.8	-	A	0.23	11.9	-
Centrum Boulevard at Brisebois Crescent West <i>Unsignalized</i>	EB	A	0.02	7.5	0.8	A	0.02	7.6	0.8
	WB	A	0.00	7.4	0.0	A	0.00	7.7	0.0
	NB	A	0.00	9.9	0.0	B	0.02	10.7	0.8
	SB	A	0.02	9.1	0.0	A	0.06	9.7	1.5
	Overall	A	-	1.3	-	A	-	2.0	-
Centrum Boulevard at Prestone Drive <i>Unsignalized</i>	EB	A	0.07	7.1	1.5	A	0.16	7.6	4.5
	WB	A	0.07	7.7	1.5	A	0.09	8.0	2.3
	NBL	A	0.08	8.5	2.3	A	0.11	9.1	3.0
	NBR	A	0.04	7.0	0.8	A	0.04	7.2	0.8
	Overall	A	-	7.6	-	A	-	8.0	-
Centrum Boulevard at Brisebois Crescent East <i>Unsignalized</i>	EB	A	0.01	7.3	0.0	A	0.01	7.3	0.0
	WB	-	-	-	-	-	-	-	-
	SB	A	0.01	8.6	0.0	A	0.02	8.5	0.0
	Overall	A	-	2.0	-	A	-	1.7	-

Intersection	Lane	AM Peak Hour				PM Peak Hour			
		LOS	V/C	Delay (s)	Q (95 th)	LOS	V/C	Delay (s)	Q (95 th)
St Joseph Boulevard at Prestone Drive Signalized	EBL	A	0.04	11.6	2.4	A	0.05	6.5	4.9
	EBT	A	0.16	12.0	11.0	A	0.40	7.4	50.2
	EBR	A	0.08	4.6	4.3	A	0.12	1.9	6.2
	WBL	A	0.01	10.5	1.1	A	0.03	6.7	2.7
	WBT	B	0.68	18.2	46.5	A	0.22	6.2	25.5
	WBR	A	0.19	3.9	7.0	A	0.11	1.9	6.0
	NBL	A	0.15	11.5	13.1	A	0.25	26.4	15.2
	NBT/R	A	0.07	9.9	8.5	A	0.12	19.3	9.7
	SBL	A	0.08	10.9	7.7	A	0.54	34.5	30.2
	SBT/R	A	0.07	8.6	6.4	A	0.32	21.7	20.5
Overall	A	0.38	14.5	-	A	0.43	9.8	-	

Notes: Saturation flow rate of 1800 veh/h/lane
 Queue is measured in metres
 Peak Hour Factor = 1.00

Delay = average vehicle delay in seconds
 m = metered queue
 # = volume for the 95th %ile cycle exceeds capacity

During both peak hours, the study area intersections operate similar to the existing condition. No capacity issues are noted.

7.2 2033 Future Background Operations

Figure 15 illustrates the 2033 background volumes and Table 18 summarizes the 2033 background intersection operations. The level of service for signalized intersections is based on v/c calculations for individual lane movements and HCM 2000 v/c calculations for the overall intersection, and average delay for unsignalized intersections. The synchro worksheets for the 2033 future background horizon are provided in Appendix H.

Figure 15: 2033 Future Background Volumes

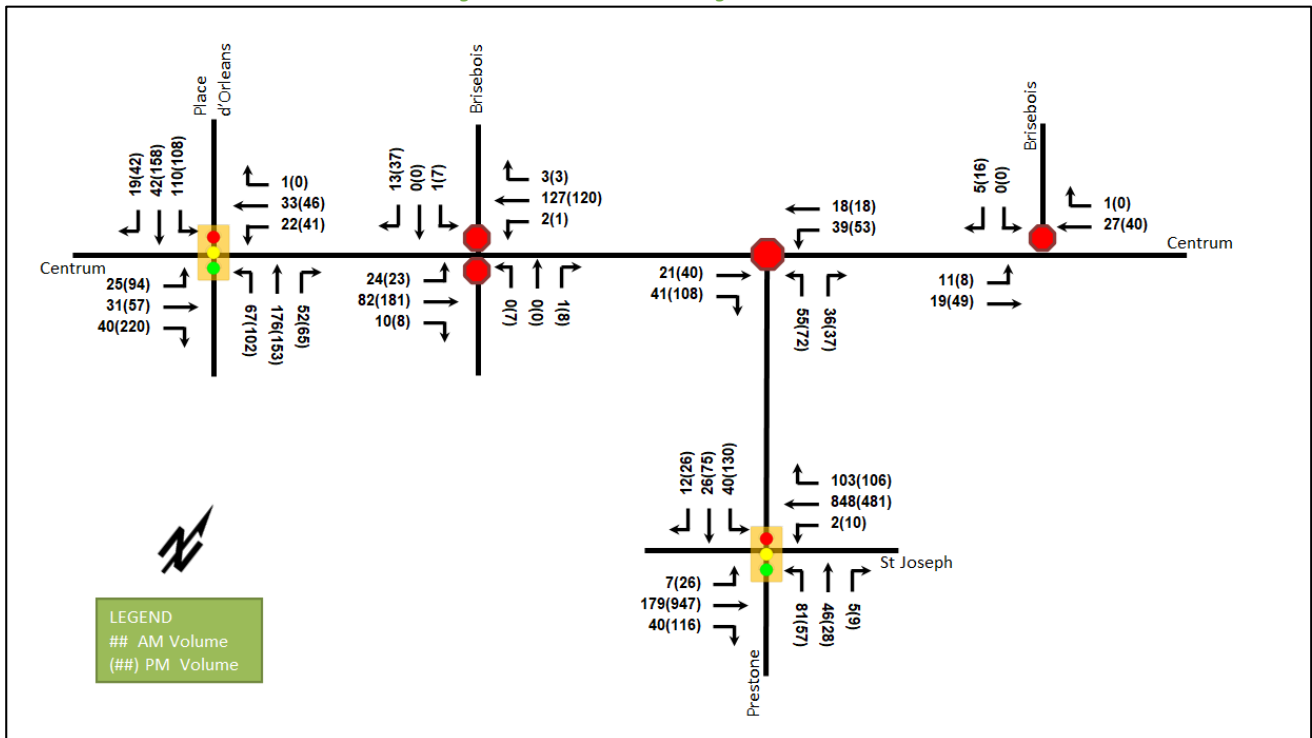

Table 18: 2033 Future Background Intersection Operations

Intersection	Lane	AM Peak Hour				PM Peak Hour			
		LOS	V/C	Delay (s)	Q (95 th)	LOS	V/C	Delay (s)	Q (95 th)
Centrum Boulevard at Place d'Orleans Drive <i>Signalized</i>	EBL	A	0.10	20.0	7.2	A	0.45	37.3	23.7
	EBT	A	0.09	19.5	8.2	A	0.20	29.8	15.2
	EBR	A	0.13	7.0	5.5	A	0.52	8.6	15.1
	WBL	A	0.08	19.6	6.5	A	0.20	30.3	12.3
	WBT/R	A	0.10	19.2	8.6	A	0.16	29.0	13.0
	NB	A	0.14	4.9	15.8	A	0.19	4.9	16.6
	SB	A	0.11	5.4	10.6	A	0.19	5.3	17.3
Overall	A	0.15	7.8	-	A	0.24	11.8	-	
Centrum Boulevard at Brisebois Crescent West <i>Unsignalized</i>	EB	A	0.02	7.5	0.8	A	0.02	7.6	0.8
	WB	A	0.00	7.4	0.0	A	0.00	7.7	0.0
	NB	A	0.00	9.9	0.0	B	0.02	10.7	0.8
	SB	A	0.02	9.2	0.0	A	0.06	9.7	1.5
Overall	A	-	1.3	-	A	-	1.9	-	
Centrum Boulevard at Prestone Drive <i>Unsignalized</i>	EB	A	0.07	7.1	1.5	A	0.16	7.6	4.5
	WB	A	0.07	7.7	1.5	A	0.09	8.0	2.3
	NBL	A	0.08	8.6	2.3	A	0.11	9.1	3.0
	NBR	A	0.04	7.0	0.8	A	0.04	7.2	0.8
Overall	A	-	7.7	-	A	-	8.0	-	
Centrum Boulevard at Brisebois Crescent East <i>Unsignalized</i>	EB	A	0.01	7.4	0.0	A	0.01	7.3	0.0
	WB	-	-	-	-	-	-	-	-
	SB	A	0.01	8.6	0.0	A	0.02	8.5	0.0
Overall	A	-	2.0	-	A	-	1.7	-	
St Joseph Boulevard at Prestone Drive <i>Signalized</i>	EBL	A	0.05	11.4	2.4	A	0.05	6.5	4.9
	EBT	A	0.15	11.6	11.0	A	0.44	7.8	56.7
	EBR	A	0.08	4.3	4.3	A	0.12	1.9	6.2
	WBL	A	0.01	10.5	1.1	A	0.03	6.8	2.7
	WBT	C	0.71	18.5	52.0	A	0.22	6.2	25.8
	WBR	A	0.18	3.6	6.9	A	0.11	1.9	6.0
	NBL	A	0.15	12.3	14.0	A	0.25	26.4	15.2
	NBT/R	A	0.07	10.6	9.1	A	0.12	19.3	9.7
	SBL	A	0.08	11.8	8.2	A	0.54	34.5	30.2
	SBT/R	A	0.07	9.2	6.8	A	0.32	21.7	20.5
Overall	A	0.41	15.0	-	A	0.46	9.9	-	

Notes: Saturation flow rate of 1800 veh/h/lane
Queue is measured in metres
Peak Hour Factor = 1.00

Delay = average vehicle delay in seconds
m = metered queue
= volume for the 95th %ile cycle exceeds capacity

During both peak hours, the study area intersections operate similar to the existing condition. No capacity issues are noted.

7.3 2028 Future Total Operations

Figure 16 illustrates the 2028 total volumes and Table 19 summarizes the 2028 total intersection operations. The level of service for signalized intersections is based on v/c calculations for individual lane movements and HCM 2000 v/c calculations for the overall intersection. The synchro worksheets for the 2028 total horizon are provided in Appendix I.

Figure 16: 2028 Future Total Volumes

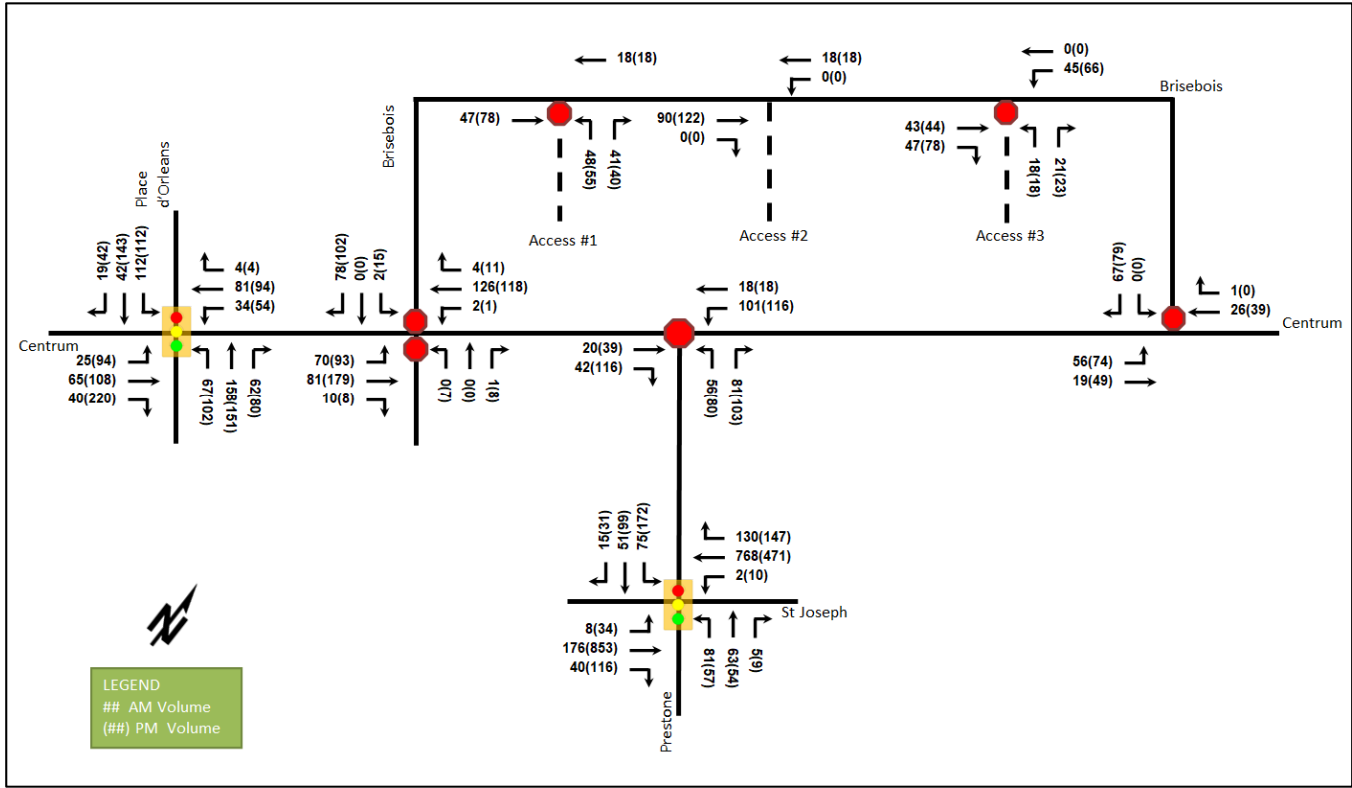

Table 19: 2028 Future Total Intersection Operations

Intersection	Lane	AM Peak Hour				PM Peak Hour			
		LOS	V/C	Delay (s)	Q (95 th)	LOS	V/C	Delay (s)	Q (95 th)
Centrum Boulevard at Place d'Orleans Drive <i>Signalized</i>	EBL	A	0.11	20.2	7.2	A	0.47	38.1	23.9
	EBT	A	0.18	21.0	14.1	A	0.37	33.3	25.3
	EBR	A	0.13	7.0	5.5	A	0.52	8.5	15.1
	WBL	A	0.14	20.6	8.9	A	0.27	32.0	15.2
	WBT/R	A	0.24	21.0	16.9	A	0.33	31.5	23.1
	NB	A	0.15	5.2	14.8	A	0.20	4.6	16.3
	SB	A	0.12	6.0	10.7	A	0.19	5.3	16.6
Overall	A	0.18	10.1	-	-	A	0.24	14.1	-
Centrum Boulevard at Brisebois Crescent West <i>Unsignalized</i>	EB	A	0.05	7.6	1.5	A	0.07	7.7	1.5
	WB	A	0.00	7.4	0.0	A	0.00	7.7	0.0
	NB	A	0.00	9.9	0.0	B	0.03	12.3	0.8
	SB	A	0.09	9.4	2.3	B	0.15	10.5	3.8
	Overall	A	-	3.5	-	-	A	-	4.0
Centrum Boulevard at Prestone Drive <i>Unsignalized</i>	EB	A	0.09	8.8	2.3	A	0.13	9.4	3.0
	WB	A	0.10	7.4	2.3	A	0.13	7.9	3.0
	NBL	A	0.07	7.4	1.5	A	0.18	8.0	4.5
	NBR	A	0.15	8.3	3.8	A	0.18	8.8	4.5
	Overall	A	-	8.0	-	-	A	-	8.5

Intersection	Lane	AM Peak Hour				PM Peak Hour			
		LOS	V/C	Delay (s)	Q (95 th)	LOS	V/C	Delay (s)	Q (95 th)
Centrum Boulevard at Brisebois Crescent East <i>Unsignalized</i>	EB	A	0.04	7.4	0.8	A	0.05	7.4	0.8
	WB	-	-	-	-	-	-	-	-
	SB	A	0.07	8.9	1.5	A	0.08	8.8	1.5
	Overall	A	-	6.0	-	A	-	5.2	-
St Joseph Boulevard at Prestone Drive <i>Signalized</i>	EBL	A	0.05	11.8	2.7	A	0.06	7.1	6.0
	EBT	A	0.16	12.0	10.9	A	0.40	8.1	49.5
	EBR	A	0.08	4.6	4.3	A	0.12	2.0	6.2
	WBL	A	0.01	10.5	1.1	A	0.03	7.2	2.7
	WBT	B	0.68	18.1	46.4	A	0.22	6.8	25.2
	WBR	A	0.23	3.8	7.8	A	0.15	1.8	6.9
	NBL	A	0.15	11.5	13.2	A	0.24	25.5	15.2
	NBT/R	A	0.09	10.1	10.7	A	0.19	21.3	14.9
	SBL	A	0.15	11.5	12.5	B	0.67	39.5	39.8
	SBT/R	A	0.11	9.3	9.9	A	0.38	23.6	26.2
	Overall	A	0.38	14.1	-	A	0.47	11.5	-
Access #1 at Brisebois Crescent <i>Unsignalized</i>	EB	-	-	-	-	-	-	-	-
	WB	-	-	-	-	-	-	-	-
	NB	A	0.09	9.1	2.3	A	0.10	9.3	2.3
	Overall	A	-	5.3	-	A	-	4.6	-
Access #2 at Brisebois Crescent <i>Unsignalized</i>	EB	Low volumes do not return operational results.							
	WB								
	Overall								
Access #3 at Brisebois Crescent <i>Unsignalized</i>	EB	-	-	-	-	-	-	-	-
	WB	A	0.03	7.5	0.8	A	0.05	7.6	0.8
	NB	A	0.04	9.2	0.8	A	0.05	9.4	1.5
	Overall	A	-	4.0	-	A	-	3.9	-

Notes: Saturation flow rate of 1800 veh/h/lane
 Queue is measured in metres
 Peak Hour Factor = 1.00

Delay = average vehicle delay in seconds
 m = metered queue
 # = volume for the 95th %ile cycle exceeds capacity

During both peak hours, the study area intersections operate similar to the 2028 future background condition. No capacity issues are noted.

7.4 2033 Future Total Operations

Figure 17 illustrates the 2033 total volumes and Table 20 summarizes the 2033 total intersection operations. The level of service for signalized intersections is based on v/c calculations for individual lane movements and HCM 2000 v/c calculations for the overall intersection. The synchro worksheets for the 2033 future total horizon are provided in Appendix J.

Figure 17: 2033 Future Total Volumes

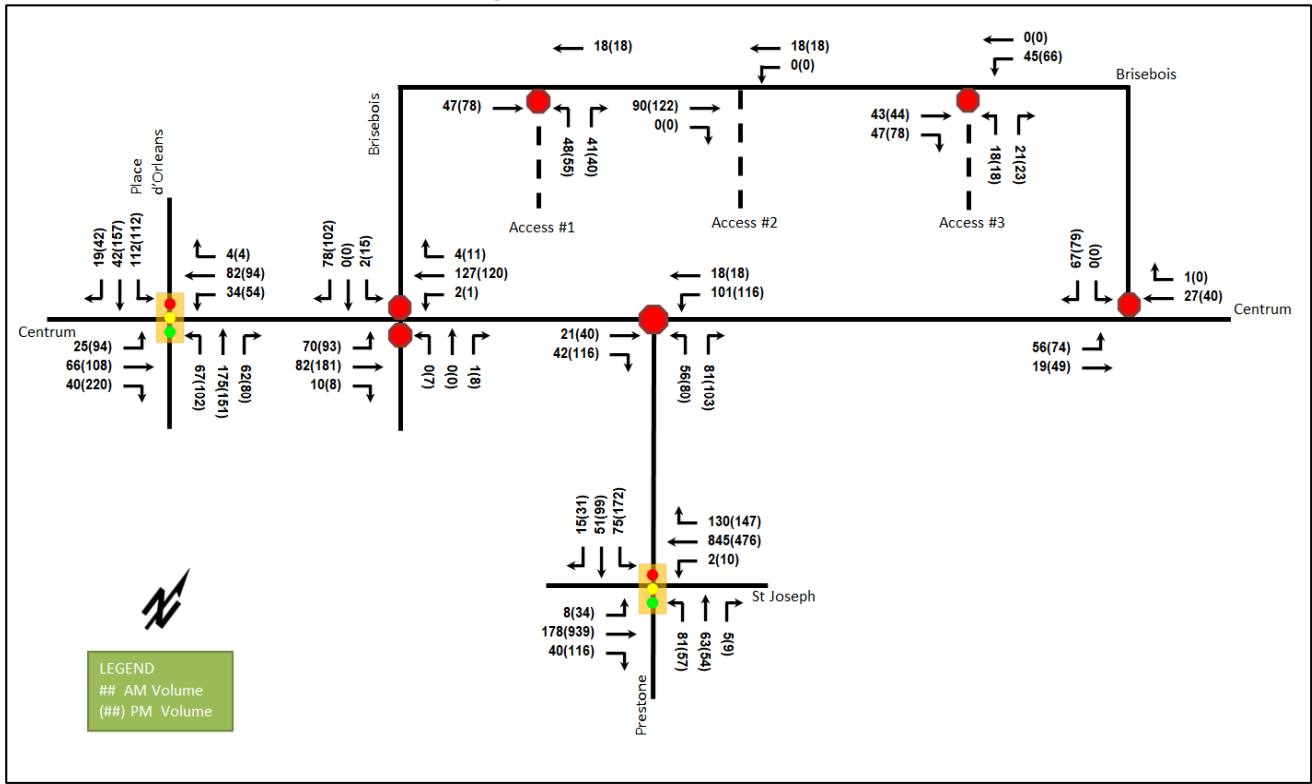

Table 20: 2033 Future Total Intersection Operations

Intersection	Lane	AM Peak Hour				PM Peak Hour			
		LOS	V/C	Delay (s)	Q (95 th)	LOS	V/C	Delay (s)	Q (95 th)
Centrum Boulevard at Place d'Orleans Drive <i>Signalized</i>	EBL	A	0.11	20.2	7.2	A	0.47	38.2	23.9
	EBT	A	0.19	21.0	14.1	A	0.37	33.4	25.3
	EBR	A	0.13	7.0	5.5	A	0.52	8.5	15.1
	WBL	A	0.14	20.6	8.9	A	0.27	32.1	15.2
	WBT/R	A	0.25	21.0	17.0	A	0.34	31.6	23.1
	NB	A	0.16	5.3	15.8	A	0.20	4.6	16.3
	SB	A	0.12	6.0	10.7	A	0.19	5.4	17.5
Overall	A	0.19	10.1	-	-	A	0.24	14.0	-
Centrum Boulevard at Brisebois Crescent West <i>Unsignalized</i>	EB	A	0.05	7.6	1.5	A	0.07	7.8	1.5
	WB	A	0.00	7.4	0.0	A	0.00	7.7	0.0
	NB	A	0.00	9.9	0.0	B	0.03	12.3	0.8
	SB	A	0.09	9.4	2.3	B	0.15	10.5	3.8
	Overall	A	-	3.5	-	A	-	4.0	-
Centrum Boulevard at Prestone Drive <i>Unsignalized</i>	EB	A	0.07	7.4	1.5	A	0.18	8.0	4.5
	WB	A	0.15	8.3	3.8	A	0.18	8.8	4.5
	NBL	A	0.09	8.8	2.3	A	0.13	9.4	3.0
	NBR	A	0.10	7.4	2.3	A	0.13	7.9	3.0
	Overall	A	-	8.0	-	A	-	8.5	-

Intersection	Lane	AM Peak Hour				PM Peak Hour			
		LOS	V/C	Delay (s)	Q (95 th)	LOS	V/C	Delay (s)	Q (95 th)
Centrum Boulevard at Brisebois Crescent East <i>Unsignalized</i>	EB	A	0.04	7.4	0.8	A	0.05	7.4	0.8
	WB	-	-	-	-	-	-	-	-
	SB	A	0.07	8.9	1.5	A	0.08	8.8	1.5
	Overall	A	-	5.9	-	A	-	5.2	-
St Joseph Boulevard at Prestone Drive <i>Signalized</i>	EBL	A	0.05	11.6	2.7	A	0.06	7.1	6.0
	EBT	A	0.15	11.6	10.9	A	0.44	8.5	56.1
	EBR	A	0.08	4.3	4.3	A	0.12	2.0	6.2
	WBL	A	0.00	10.5	1.1	A	0.03	7.3	2.7
	WBT	B	0.70	18.3	51.7	A	0.23	6.8	25.5
	WBR	A	0.22	3.6	7.7	A	0.15	1.8	6.9
	NBL	A	0.16	12.4	14.0	A	0.24	25.5	15.2
	NBT/R	A	0.09	11.0	11.3	A	0.19	21.3	14.9
	SBL	A	0.15	12.4	13.3	B	0.67	39.5	39.8
	SBT/R	A	0.12	10.0	10.4	A	0.38	23.6	26.2
	Overall	A	0.41	14.5	-	A	0.50	11.5	-
Access #1 at Brisebois Crescent <i>Unsignalized</i>	EB	-	-	-	-	-	-	-	-
	WB	-	-	-	-	-	-	-	-
	NB	A	0.09	9.1	2.3	A	0.10	9.3	2.3
	Overall	A	-	5.3	-	A	-	4.6	-
Access #2 at Brisebois Crescent <i>Unsignalized</i>	EB	Low volumes do not return operational results.							
	WB								
	Overall								
Access #3 at Brisebois Crescent <i>Unsignalized</i>	EB	-	-	-	-	-	-	-	-
	WB	A	0.03	7.5	0.8	A	0.05	7.6	0.8
	NB	A	0.04	9.2	0.8	A	0.05	9.4	1.5
	Overall	A	-	4.0	-	A	-	3.9	-

Notes: Saturation flow rate of 1800 veh/h/lane
 Queue is measured in metres
 Peak Hour Factor = 1.00

Delay = average vehicle delay in seconds
 m = metered queue
 # = volume for the 95th %ile cycle exceeds capacity

During both peak hours, the study area intersections operate similar to the 2033 future background condition. No capacity issues are noted.

7.5 Modal Share Sensitivity and Demand Rationalization Conclusions

During both peak hours, the study area intersections operate well, and no demand rationalization is required for this TIA.

The network intersection exemptions noted in Section 3.1 are validated in the low impact the development on intersections in close proximity to the site.

8 Development Design

8.1 Design for Sustainable Modes

The proposed development includes two residential towers and a mixed-use tower. The bicycle parking spaces are proposed as accessing the parking garage ramp. The site plan proposes a total of 1,254 bicycle parking spaces with 1,194 bicycle indoor parking spaces and 60 exterior bicycle parking spaces. Hard surface connections are provided between building entrances and a 2.0-meter-wide concrete sidewalk will be provided along the frontage of Brisebois Crescent. Local bus stops are located within 400 metres of the site entrances at Centrum Boulevard and Prestone Drive. Place d'Orléans station is approximately one kilometre walking distance from the site.

8.2 Circulation and Access

The proposed development will remove two existing accesses on Brisebois Crescent and propose three accesses on Brisebois Crescent. Access #1 will be a two-way access with a connection to the underground parking levels, and a one-way loop will form the inbound Access #2 and outbound Access #3. The one-way loop will permit temporary parking for deliveries, ubers, etc. and internal loading zones will be provided for each building for garbage collection and move-in truck operations. Two-way operation is permitted to the loading zone for Tower A from the one-way loop.

9 Parking

9.1 Parking Supply

The site proposes a total of 516 vehicle parking spaces. A total of 1254 bicycle parking spaces are proposed with 1,194 spaces provided indoor and 60 spaces provided exterior.

From the zoning by-law, the minimum vehicle parking provision for office is 70 parking spaces and for retail is 90 parking spaces. There are no minimum vehicle parking requirements for the residential units.

The site proposes a total of 21 accessible parking spaces, and it meets the requirement of 16 accessible parking spaces for office and retails.

The site meets the minimum vehicle parking, bicycle parking, and accessible parking requirements.

10 Boundary Street Design

Table 21 summarizes the MMLOS analysis for the boundary streets of Brisebois Crescent and Centrum Boulevard. The existing and future conditions for both streets will be the same and are considered in one row. The boundary street analysis is based on the land-use of the “General Urban Area”. The MMLOS worksheets have been provided in Appendix K.

Table 21: Boundary Street MMLOS Analysis

Segment	Pedestrian LOS		Bicycle LOS		Transit LOS		Truck LOS	
	PLOS	Target	BLOS	Target	TLOS	Target	TrLOS	Target
Brisebois Crescent (Existing)	F	B	D	D	N/A	N/A	N/A	N/A
Brisebois Crescent (Future)	C	B	D	D	N/A	N/A	N/A	N/A
Centrum Boulevard	B	B	B	D	N/A	N/A	N/A	N/A

The pedestrian LOS will not be met along the segment of Brisebois Crescent. A 2.0-meter-wide sidewalk will be provided along the boundary street of Brisebois Crescent, and it will improve the PLOS from F to C. To meet the theoretical pedestrian LOS targets, the boulevards would need to be at least 0.5 metres or the operating speed would need to be less than 50 km/h along boundary street of Brisebois Crescent.

Brisebois Crescent will have sidewalks on both sides of the roadway and will meet local road standards for the cross-section. No further improvements are required to meet the PLOS targets, although the City may look at reducing the speed limit to help improve the PLOS results (e.g. 40 km/h would become PLOS B).

11 Access Intersections Design

11.1 Location and Design of Access

The development proposed three accesses to Brisebois Crescent and is in compliance with the private approach bylaw for number and operation of the permitted accesses. The Access #1 is a two-way access with a 6.7 metre

width and connects to the ground level parking and underground garage. The Access #2 and Access #3 are one-way access are 6.0 metres wide, operating as an one-way loop, inbound on Access #2 and outbound on Access #3. The throat length for each access meets the private approach bylaw requirements.

11.2 Intersection Control

Based upon the projected volumes, Accesses #1 and #3 will have stop-control each on the minor approach and Access #2 will have no control as it is inbound only.

11.3 Access Intersection Design

11.3.1 Future Access Intersection Operations

The operations are noted in Section 7.4 and no mitigation is required for the development.

11.3.2 Access Intersection MMLOS

All accesses are unsignalized and do not require MMLOS review.

11.3.3 Recommended Design Elements

The Brisebois Crescent frontage will be formalized to a local road standard with the perpendicular parking being removed and replaced by a 2.0-meter-wide sidewalk and grass boulevard. The sidewalk will tie into the existing sidewalk at the corner of Brisebois Crescent as it bends towards Centrum Boulevard. The proposed accesses will be constructed to comply with the City standard SC7.1.

12 Transportation Demand Management

12.1 Context for TDM

The subject site has been assumed to rely predominantly on auto driver and transit mode shares due to the conversion of the Place d'Orleans LRT station. The convenience of the transit station should provide the opportunity to reach the forecast transit mode share.

12.2 Need and Opportunity

The subject site has been assumed to rely predominantly on auto and transit travel, and those assumptions have been carried through the analysis. As the unmodified district mode shares have been applied, risks to other network users from failing to meet mode share targets are low.

12.3 TDM Program

The “suite of post occupancy TDM measures” has been summarized in the TDM checklists for the residential land uses. The checklist is provided in Appendix L. Transit-oriented design of the subject site is confirmed by the City of Ottawa during the pre-consultation meeting, and the key TDM measures recommended include:

- Designate an internal coordinator, or contract with an external coordinator
- Display local area maps with walking/cycling access routes and key destinations at major entrances
- Display relevant transit schedules and route maps at entrances
- Provide online links to OC Transpo and STO information
- Provide a dedicated ridematching portal at OttawaRideMatch.com
- Provide a multimodal travel option information package to new/relocating employees, students, and new residents
- Unbundle parking costs from lease rates at multi-tenant sites, purchase or rental costs
- Offer personalized trip planning to new/relocating employees

13 Neighbourhood Traffic Management

The proposed development will connect to the arterial network via Brisebois Crescent (a local road), Centrum Boulevard (a collector road), and Prestone Drive (a collector road). The TIA guidelines have outlined thresholds for two-way traffic on local and collector roads and have been found to be too low for the purposes of this analysis. City Staff have noted that these thresholds are under review and will be updated in the future.

In general, Brisebois Crescent is anticipated to convey between 105 to 153 vehicles during the peak hours, Centrum Boulevard will range between 137 to 336 vehicles west of Prestone Drive and 28 to 252 vehicles east of Prestone Drive during the peak hours. Prestone Drive is anticipated to convey between 280 to 415 vehicles north of St. Joseph Boulevard during the peak hours. No changes to the roadway classifications or proposed road network are required to support the site.

14 Transit

14.1 Route Capacity

In Section 5.1 the trip generation by mode was estimated, including an estimate of the number of transit trips that will be generated by the proposed development. Table 22 summarizes the transit trip generation.

Table 22: Trip Generation by Transit Mode

Travel Mode	Mode Share	AM Peak Hour			PM Peak Hour		
		In	Out	Total	In	Out	Total
Transit	varies	82	154	236	105	87	192

The proposed development is anticipated to generate an additional 236 AM and 192 PM peak hour two-way transit trips. From the trip distribution found in section 5.3, these values can be further broken down. Table 23 summarizes forecasted site-generated transit ridership trips by direction and the equivalent bus loads.

Table 23: Forecasted Site-Generated Transit Ridership

Direction	AM Peak Hour		PM Peak Hour		Service Type	Approximate Equivalent Peak Hour/Direction Bus Loads
	In	Out	In	Out		
North	4	8	5	4	Bus	Negligible
South	25	46	32	26	Bus	Half of a standard bus
East	21	39	26	22	Bus, LRT	Half of a standard bus
West	32	61	42	35	Bus, LRT	A standard bus

14.2 Transit Priority

Examining the study area intersection delays, negligible impacts are noted on the transit movements at the study area intersections. No change in transit LOS is noted throughout the study area. No specific transit priority measures were considered as part of this development.

15 Network Concept

The background and forecasted site trips do not exceed the anticipated lane capacities on the boundary road network. The transit modal share is likely to be achieved and the site has negligible impact on the road network. No future network changes are required to support the subject development.

16 Network Intersection Design

16.1 Network Intersection Control

No change to the existing signalized control is recommended for the network intersections.

16.2 Network Intersection Design

16.2.1 2028 & 2033 Future Total Network Intersection Operations

The operations are noted in Section 7.4 and no mitigation of conditions is required for the subject site traffic.

16.2.2 Network Intersection MMLoS

Table 24 summarizes the MMLoS analysis for the network intersections of Centrum Boulevard at Place d’Orleans Drive and St Joseph Boulevard at Prestone Drive. The existing and future conditions for both intersections will be the same and are considered in one row. The intersection analysis is based on the land-use of the “Mixed Use Centre” for existing condition and “Within 600m of a rapid transit station” for future conditions. The MMLoS worksheets have been provided in Appendix K.

Table 24: Study Area Intersection MMLoS Analysis

Intersection	Pedestrian LOS		Bicycle LOS		Transit LOS		Truck LOS		Auto LOS	
	PLOS	Target (Ex/Fu)	BLOS	Target (Ex/Fu)	TLOS	Target (Ex/Fu)	TrLOS	Target (Ex/Fu)	ALOS	Target (Ex/Fu)
Centrum Boulevard at Place d’Orleans Drive	F	C/A	F	A/A	N/A	N/A	N/A	N/A	A	D/D
St Joseph Boulevard at Prestone Drive	F	C/A	F	B/B	N/A	N/A	N/A	N/A	A	D/D

The pedestrian LOS targets will not be met at the study area intersections. As typical for arterial roads, the crossing distance does not permit the targets to be met. To meet pedestrian LOS targets, the maximum crossing distance on all pedestrian crossings would need to be reduced to three lane-widths.

Pedestrian delay LOS is not considered in the PLOS calculation as it is not a suitable metric for the assessment of pedestrian LOS as formulated. This exclusion is consistent with City direction since 2015, and no alternative methodology has been provided for its assessment.

The bicycle LOS targets will not be met at the study area intersections, and two-stage left turns or left-turn boxes would be required to meet LOS targets on all below-target approaches.

The City of Ottawa will be responsible for exploring options to address the area PLOS and BLOS deficiencies, given they are arterial road intersections and may require greater network improvements beyond the localized intersection upgrades.

16.2.3 Recommended Design Elements

No study area intersection design elements are proposed as part of this study.

17 Summary of Improvements Indicated and Modifications Options

The following summarizes the analysis and results presented in this TIA report:

Proposed Site and Screening

- The proposed site includes 1,127 residential units, 8,970 sq. ft retail space, and 31,570 sq. ft office space
- The preliminary accesses are proposed to include three along Brisebois Crescent, and the existing two accesses on Brisebois Crescent will be removed
- The development is proposed to be completed as a single phase by 2028
- The Trip Generation and safety triggers were met for the TIA Screening

Existing Conditions

- Place d'Orleans Drive and St Joseph Boulevard are arterial roads, and Centrum Boulevard and Prestone Drive are collector roads in the study area
- Sidewalks are provided on both sides of Place d'Orleans Drive, St Joseph Boulevard, Centrum Boulevard, and Prestone Drive, and one side of Brisebois Crescent
- St Joseph Boulevard is a cross-town bikeway, and Place d'Orleans Drive and Prestone Drive south of St Joseph Boulevard are local routes
- Within the study area, the intersection of St Joseph Boulevard at Prestone Drive is noted to have experienced higher collisions than other locations (11 of 32)
- The majority of the collisions (7 of 11) occurred during 2017 and 2018 at the intersection of St Joseph Boulevard at Prestone Drive when there was resurfacing operations occurred through the intersection, which is assumed to be the cause of the elevated collision rate during these two years

Development Generated Travel Demand

- A 15% shift to transit mode from the auto mode for residential land use and a 10% shift to transit mode from the auto mode for commercial land use are proposed because of the conversion of the future Place d'Orleans LRT station and being design priority area with good access to transit
- The proposed development is forecasted to produce 544 two-way people trips during the AM peak hour and 554 two-way people trips during the PM peak hour
- Of the forecasted people trips, 210 two-way trips will be vehicle trips during the AM peak hour and 248 two-way trips will be vehicle trips during the PM peak hour
- Of the forecasted trips, 5 % are anticipated to travel north, 30% to the south, 25% to the east, and 40 % to the west

Background Conditions

- The background developments were explicitly included in the background conditions, along with background growths per annum applied along the mainline directions/volumes on Centrum Boulevard, St Joseph Boulevard, and Place d'Orleans Drive
- The study area intersections at the 2028 and 2033 background conditions will operate similar to the existing conditions
- Place d'Orleans station, which is located approximately 800 metres from the site, will be converted to accommodate LRT by the end of 2024

Development Design

- The site plan proposes a total of 1,254 bicycle parking spaces with 1,194 bicycle indoor parking spaces and 60 exterior bicycle parking spaces
- Hard surface connections are provided between building entrances and a 2.0m wide concrete sidewalk will be provided along the frontage of Brisebois Crescent
- Local bus stops are located within 400 metres of the site entrances and the Place d'Orléans station is approximately one kilometre walking distance from the site
- Access #1 will be a two-way access with a connection to the underground parking levels, and a one-way loop will form the inbound Access #2 and outbound Access #3
- The one-way loop will permit temporary parking for deliveries, ubers, etc. and internal loading zones will be provided for each building for garbage collection and move-in truck operations
- Two-way operation is permitted to the loading zone for Tower A from the one-way loop

Parking

- The site plan proposes a total of 516 vehicle parking spaces
- A total of 1,254 bicycle parking spaces are proposed with 1,194 spaces provided indoor and 60 spaces provided exterior
- The site proposes a total of 21 accessible parking spaces
- The site meets the minimum vehicle parking, bicycle parking, and accessible parking requirements
- There are no minimum vehicle parking requirements for the residential units

Boundary Street Design

- The pedestrian LOS will not be met along the segment of Brisebois Crescent, and at least 0.5 metres of boulevards or less than 50 km/h of operating speed would need to meet the target
- A 2.0-meter-wide sidewalk will be provided along the boundary road of Brisebois Crescent, and it will improve the PLOS from F to C
- No further improvements are required to meet the PLOS targets, although the City may look at reducing the speed limit to help improve the PLOS results

Access Intersections Design

- The Access #1 is a two-way access with a 6.7 metre width and connects to the ground level parking and underground garage
- The Access #2 and Access #3 are one-way access are 6.0 metres wide, operating as an one-way loop, inbound on Access #2 and outbound on Access #3
- The throat length for each access meets the private approach bylaw requirements
- Accesses #1 and #3 will have stop-control each on the minor approach and Access #2 will have no control as it is inbound only
- The Brisebois Crescent frontage will be formalized to a local road standard with the perpendicular parking being removed and replaced by a 2.0-meter-wide sidewalk and grass boulevard

TDM

- Supportive TDM measures to be included within the proposed development should include:
 - Designate an internal coordinator, or contract with an external coordinator

- Display local area maps with walking/cycling access routes and key destinations at major entrances
- Display relevant transit schedules and route maps at entrances
- Provide online links to OC Transpo and STO information
- Provide a dedicated ridematching portal at OttawaRideMatch.com
- Provide a multimodal travel option information package to new/relocating employees, students, and new residents
- Unbundle parking costs from lease rates at multi-tenant sites, purchase or rental costs
- Offer personalized trip planning to new/relocating employees

NTM

- The proposed development will connect to the arterial network via Brisebois Crescent (a local road), Centrum Boulevard (a collector road), and Prestone Drive (a collector road)
- No changes to the roadway classifications or proposed road network are required to support the site

Transit

- The forecasted transit trips will include 236 two-way trips during the AM peak and 192 two-way trips during the PM peak
- Peak hour increases in transit ridership resulting from the site equate to half of a standard bus load southerly and easterly of the site, a standard bus load westerly of the site, and negligible impact northerly of the site
- Negligible impacts are noted on the transit movements at the study area intersections
- No specific transit priority measures were considered as part of this development

Network Concept

- The transit modal share is likely to be achieved and the site has negligible impact on the road network
- No future network changes are required to support the subject development

Network Intersection Design

- No change to the existing signalized control is recommended for the network intersections
- Generally, the network intersections will operate similar to the background conditions
- The pedestrian LOS targets will not be met at the study area intersections, and the maximum crossing distance on all pedestrian crossings are required to be reduced to three lane-widths
- The bicycle LOS targets will not be met at the study area intersections, and two-stage left turns or left-turn boxes would be required to meet LOS targets on all below-target approaches
- The City of Ottawa will be responsible for exploring options to address the area PLOS and BLOS deficiencies, given they are arterial road intersections and may require greater network improvements beyond the localized intersection upgrades

18 Conclusion

It is recommended that, from a transportation perspective, the proposed development applications proceed.

Prepared By:



Yu-Chu Chen, EIT
Transportation Engineering-Intern

Reviewed By:



Andrew Harte, P.Eng.
Senior Transportation Engineer

Appendix A

TIA Screening Form and PM Certification Form

City of Ottawa 2017 TIA Guidelines
Step 1 - Screening Form

Date: 23-Mar-23
Project Number: 2023-013
Project Reference: 265 Centrum

1.1 Description of Proposed Development	
Municipal Address	265 Centrum Boulevard
Description of Location	Existing YMCA site. Bounded by Centrum Boulevard to the south, Brisebois Crescent to the north and east, and the Shenkman Arts Centre to the west
Land Use Classification	Mixed-Use Centre Zone (MC14[1520] S152)
Development Size	Three (3) towers with a total of 1,127 residential units, 8,970 sq. ft retail space, and 31,570 sq. ft office space
Accesses	Three accesses on Brisebois Crescent
Phase of Development	Single
Buildout Year	2028
TIA Requirement	Full TIA Required

1.2 Trip Generation Trigger	
Land Use Type	Townhomes or apartments
Development Size	1093 Units
Trip Generation Trigger	Yes

1.3 Location Triggers	
Does the development propose a new driveway to a boundary street that is designated as part of the City's Transit Priority, Rapid Transit or Spine Bicycle Networks?	No
Is the development in a Design Priority Area (DPA) or Transit-oriented Development (TOD) zone?	No Heart of Orleans BIA
Location Trigger	No

1.4. Safety Triggers	
Are posted speed limits on a boundary street 80 km/hr or greater?	No
Are there any horizontal/vertical curvatures on a boundary street limits sight lines at a proposed driveway?	Yes Brisebois curvature. It's a local with low volumes. No issue.
Is the proposed driveway within the area of influence of an adjacent traffic signal or roundabout (i.e. within 300 m of intersection in rural conditions, or within 150 m of intersection in urban/ suburban conditions)?	No
Is the proposed driveway within auxiliary lanes of an intersection?	No
Does the proposed driveway make use of an existing median break that serves an existing site?	No
Is there is a documented history of traffic operations or safety concerns on the boundary streets within 500 m of the development?	No
Does the development include a drive-thru facility?	No
Safety Trigger	Yes



TIA Plan Reports

On 14 June 2017, the Council of the City of Ottawa adopted new Transportation Impact Assessment (TIA) Guidelines. In adopting the guidelines, Council established a requirement for those preparing and delivering transportation impact assessments and reports to sign a letter of certification.

Individuals submitting TIA reports will be responsible for all aspects of development-related transportation assessment and reporting, and undertaking such work, in accordance and compliance with the City of Ottawa's Official Plan, the Transportation Master Plan and the Transportation Impact Assessment (2017) Guidelines.

By submitting the attached TIA report (and any associated documents) and signing this document, the individual acknowledges that s/he meets the four criteria listed below.

CERTIFICATION

1. I have reviewed and have a sound understanding of the objectives, needs and requirements of the City of Ottawa's Official Plan, Transportation Master Plan and the Transportation Impact Assessment (2017) Guidelines;
2. I have a sound knowledge of industry standard practice with respect to the preparation of transportation impact assessment reports, including multi modal level of service review;
3. I have substantial experience (more than 5 years) in undertaking and delivering transportation impact studies (analysis, reporting and geometric design) with strong background knowledge in transportation planning, engineering or traffic operations; and
4. I am either a licensed¹ or registered² professional in good standing, whose field of expertise [check appropriate field(s)] is either transportation engineering or transportation planning .

1,2 License of registration body that oversees the profession is required to have a code of conduct and ethics guidelines that will ensure appropriate conduct and representation for transportation planning and/or transportation engineering works.

City Of Ottawa
Infrastructure Services and Community
Sustainability
Planning and Growth Management
110 Laurier Avenue West, 4th fl.
Ottawa, ON K1P 1J1
Tel. : 613-580-2424
Fax: 613-560-6006

Ville d'Ottawa
Services d'infrastructure et Viabilité des
collectivités
Urbanisme et Gestion de la croissance
110, avenue Laurier Ouest
Ottawa (Ontario) K1P 1J1
Tél. : 613-580-2424
Télécopieur: 613-560-6006

Dated at Ottawa this 20 day of September, 2018.
(City)

Name: Andrew Harte
(Please Print)

Professional Title: Professional Engineer

Signature of Individual certifier that s/he meets the above four criteria

Office Contact Information (Please Print)
Address: 6 Plaza Court
City / Postal Code: Ottawa / K2H 7W1
Telephone / Extension: (613) 697-3797
E-Mail Address: Andrew.Harte@CGHTransportation.com



Appendix B

Turning Movement Counts



Transportation Services - Traffic Services

Turning Movement Count - Study Results

PLACE D'ORLEANS @ CENTRUM BLVD/PLACE D'ORLEANS

Survey Date: Thursday, January 31, 2019

WO No: 38321

Start Time: 07:00

Device: Miovision

Full Study Diagram

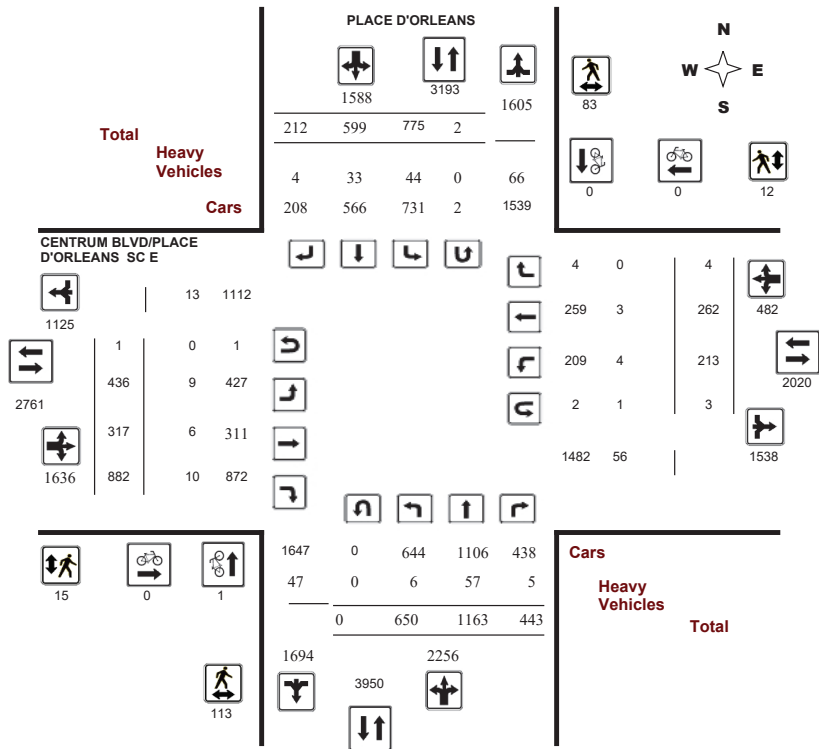

Transportation Services - Traffic Services

Turning Movement Count - Study Results

PLACE D'ORLEANS @ CENTRUM BLVD/PLACE D'ORLEANS

Survey Date: Thursday, January 31, 2019

WO No: 38321

Start Time: 07:00

Device: Miovision

Full Study Peak Hour Diagram

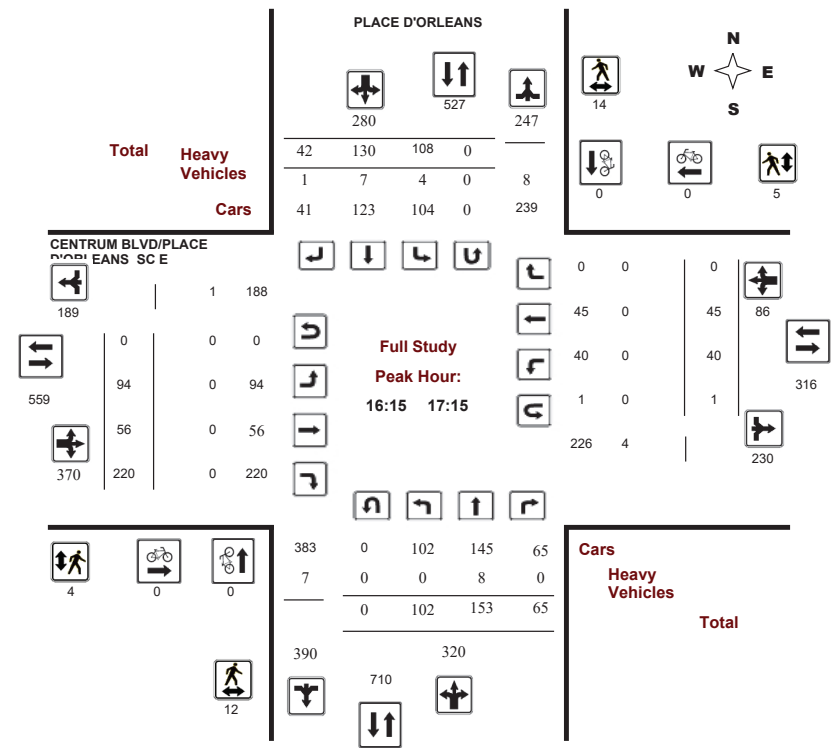



Transportation Services - Traffic Services

Turning Movement Count - Peak Hour Diagram

PLACE D'ORLEANS @ CENTRUM BLVD/PLACE D'ORLEANS

Survey Date: Thursday, January 31, 2019
Start Time: 07:00

WO No: 38321
Device: Miovision

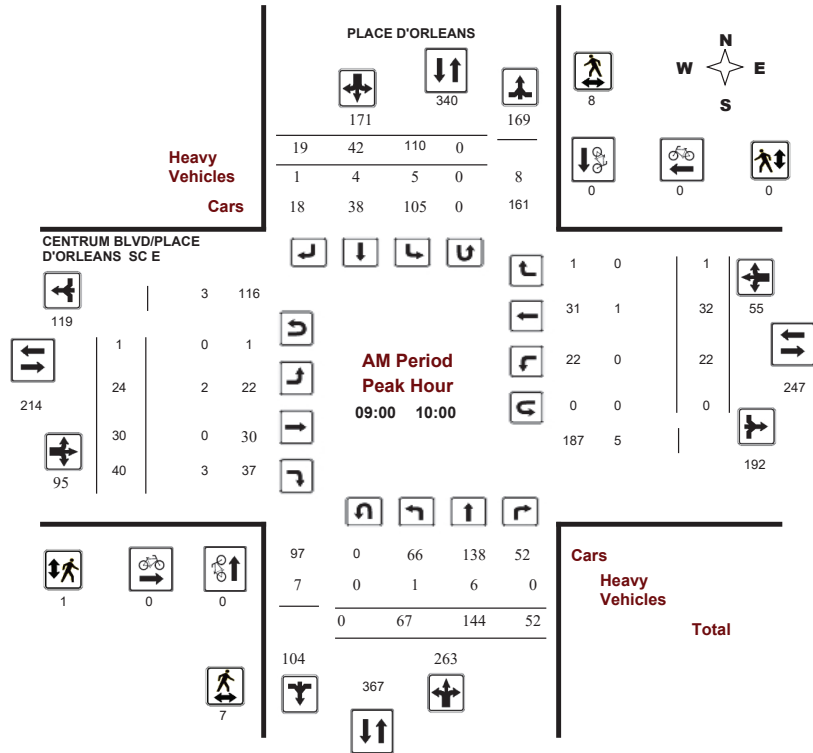

Comments



Transportation Services - Traffic Services

Turning Movement Count - Peak Hour Diagram

PLACE D'ORLEANS @ CENTRUM BLVD/PLACE D'ORLEANS

Survey Date: Thursday, January 31, 2019
Start Time: 07:00

WO No: 38321
Device: Miovision

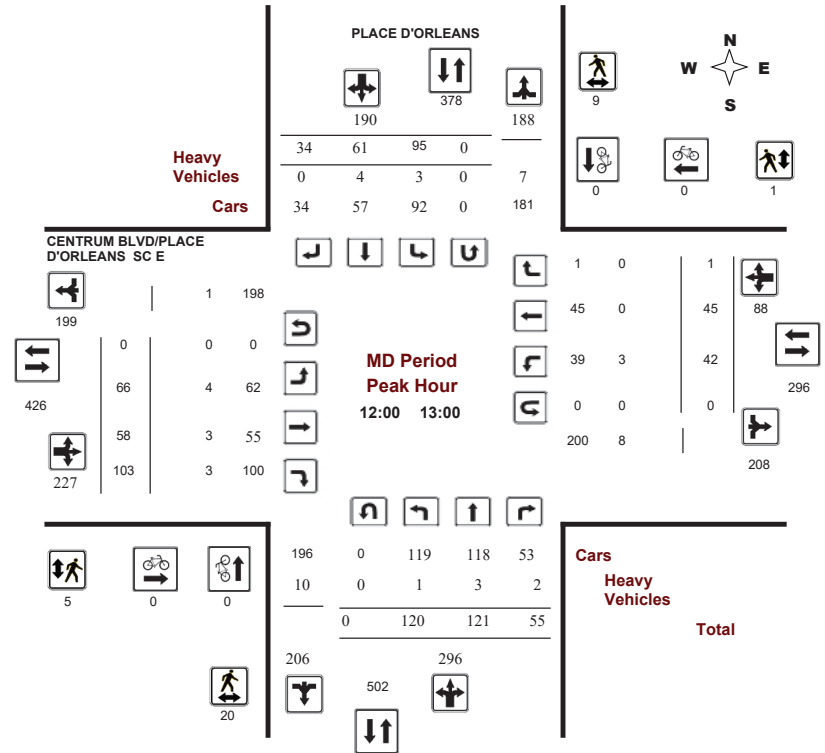

Comments



Transportation Services - Traffic Services

Turning Movement Count - Peak Hour Diagram

PLACE D'ORLEANS @ CENTRUM BLVD/PLACE D'ORLEANS

Survey Date: Thursday, January 31, 2019
Start Time: 07:00

WO No: 38321
Device: Miovision

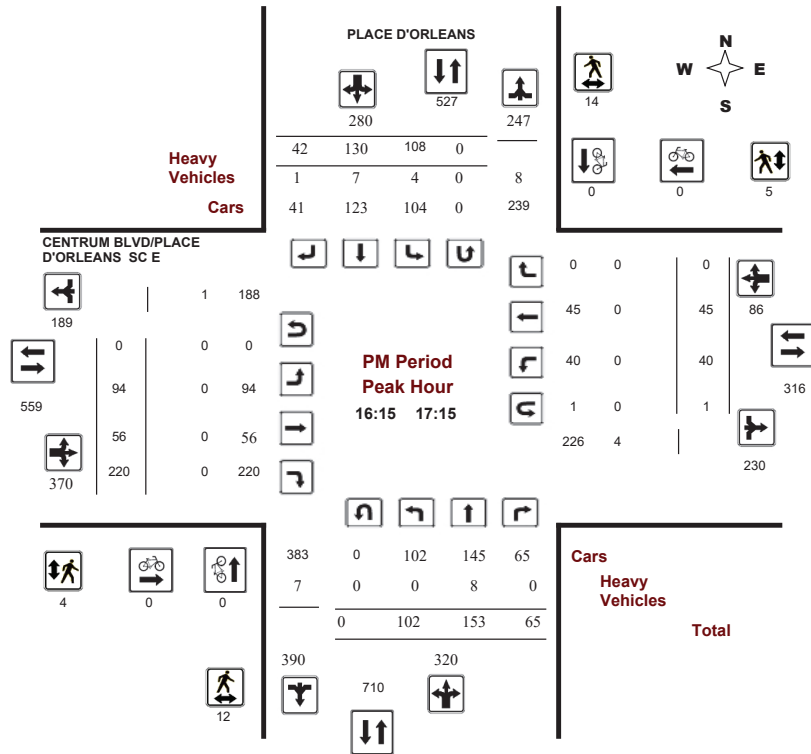

Comments



Transportation Services - Traffic Services

Turning Movement Count - Study Results

PLACE D'ORLEANS @ CENTRUM BLVD/PLACE D'ORLEANS

Survey Date: Thursday, January 31, 2019
Start Time: 07:00

WO No: 38321
Device: Miovision

Full Study Summary (8 HR Standard)

Table containing survey details, total observed u-turns, and a detailed turning movement count table for Place d'Orleans and Centrum Blvd/Place d'Orleans SC E. Includes sub-totals and expansion factors for EQ 12Hr, AVG 12Hr, and AVG 24Hr.



Transportation Services - Traffic Services

Turning Movement Count - Study Results

PLACE D'ORLEANS @ CENTRUM BLVD/PLACE D'ORLEANS

Survey Date: Thursday, January 31, 2019

WO No: 38321

Start Time: 07:00

Device: Miovision

Full Study 15 Minute Increments

Table with columns for Time Period, Northbound (LT, ST, RT, N TOT), Southbound (LT, ST, RT, S TOT), Eastbound (LT, ST, RT, E TOT), Westbound (LT, ST, RT, W TOT), and Grand Total. Rows represent 15-minute intervals from 07:00 to 18:00.

Note: U-Turns are included in Totals.



Transportation Services - Traffic Services

Turning Movement Count - Study Results

PLACE D'ORLEANS @ CENTRUM BLVD/PLACE D'ORLEANS

Survey Date: Thursday, January 31, 2019

WO No: 38321

Start Time: 07:00

Device: Miovision

Full Study Cyclist Volume

Table with columns for Time Period, PLACE D'ORLEANS (Northbound, Southbound, Street Total), CENTRUM BLVD/PLACE D'ORLEANS (Eastbound, Westbound, Street Total), and Grand Total. Rows represent 15-minute intervals from 07:00 to 18:00.



Transportation Services - Traffic Services

Turning Movement Count - Study Results

PLACE D'ORLEANS @ CENTRUM BLVD/PLACE D'ORLEANS

Survey Date: Thursday, January 31, 2019

WO No: 38321

Start Time: 07:00

Device: Miovision

Full Study Pedestrian Volume

PLACE D'ORLEANS

CENTRUM BLVD/PLACE D'ORLEANS SC E

Table with columns: Time Period, NB Approach, SB Approach, Total, EB Approach, WB Approach, Total, Grand Total. Rows show pedestrian counts from 07:00 to 18:00.



Transportation Services - Traffic Services

Turning Movement Count - Study Results

PLACE D'ORLEANS @ CENTRUM BLVD/PLACE D'ORLEANS

Survey Date: Thursday, January 31, 2019

WO No: 38321

Start Time: 07:00

Device: Miovision

Full Study Heavy Vehicles

PLACE D'ORLEANS

CENTRUM BLVD/PLACE D'ORLEANS SC E

Table with columns: Time Period, Northbound (LT, ST, RT, N TOT), Southbound (LT, ST, RT, S TOT), Eastbound (LT, ST, RT, E TOT), Westbound (LT, ST, RT, W TOT), STR TOT, Grand Total. Rows show heavy vehicle counts from 07:00 to 18:00.



Transportation Services - Traffic Services

Turning Movement Count - Study Results

PLACE D'ORLEANS @ CENTRUM BLVD/PLACE D'ORLEANS

Survey Date: Thursday, January 31, 2019

WO No: 38321

Start Time: 07:00

Device: Miovision

Full Study 15 Minute U-Turn Total

Time Period	PLACE D'ORLEANS		CENTRUM BLVD/PLACE D'ORLEANS		Total
	Northbound U-Turn Total	Southbound U-Turn Total	Eastbound U-Turn Total	Westbound U-Turn Total	
07:00 - 07:15	0	2	0	0	2
07:15 - 07:30	0	0	0	0	0
07:30 - 07:45	0	0	0	1	1
07:45 - 08:00	0	0	0	0	0
08:00 - 08:15	0	0	0	0	0
08:15 - 08:30	0	0	0	0	0
08:30 - 08:45	0	0	0	0	0
08:45 - 09:00	0	0	0	0	0
09:00 - 09:15	0	0	0	0	0
09:15 - 09:30	0	0	1	0	1
09:30 - 09:45	0	0	0	0	0
09:45 - 10:00	0	0	0	0	0
11:30 - 11:45	0	0	0	1	1
11:45 - 12:00	0	0	0	0	0
12:00 - 12:15	0	0	0	0	0
12:15 - 12:30	0	0	0	0	0
12:30 - 12:45	0	0	0	0	0
12:45 - 13:00	0	0	0	0	0
13:00 - 13:15	0	0	0	0	0
13:15 - 13:30	0	0	0	0	0
15:00 - 15:15	0	0	0	0	0
15:15 - 15:30	0	0	0	0	0
15:30 - 15:45	0	0	0	0	0
15:45 - 16:00	0	0	0	0	0
16:00 - 16:15	0	0	0	0	0
16:15 - 16:30	0	0	0	0	0
16:30 - 16:45	0	0	0	1	1
16:45 - 17:00	0	0	0	0	0
17:00 - 17:15	0	0	0	0	0
17:15 - 17:30	0	0	0	0	0
17:30 - 17:45	0	0	0	0	0
17:45 - 18:00	0	0	0	0	0
Total	0	2	1	3	6



Turning Movement Count Summary, AM and PM Peak Hour Flow Diagrams

Automobiles, Taxis, Light Trucks, Vans, SUV's, Motorcycles, Heavy Trucks, Buses, and School Buses

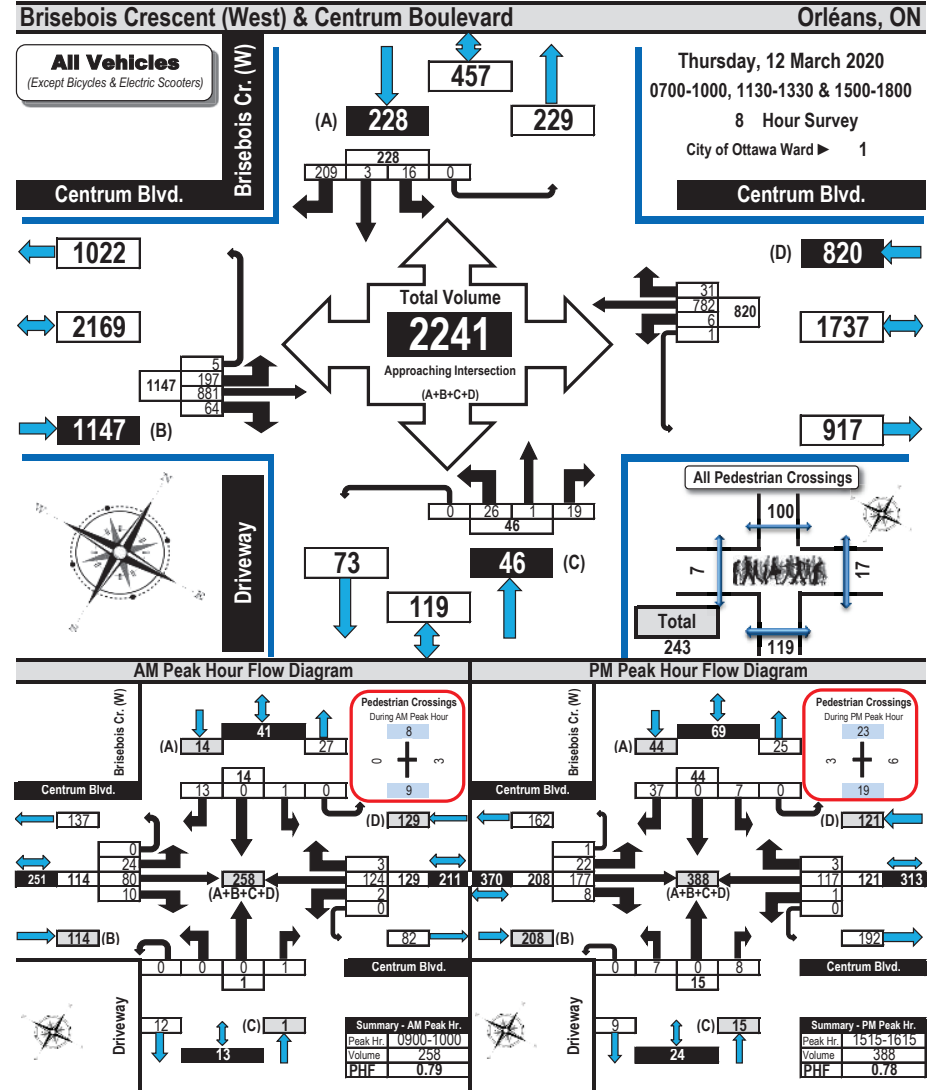



Turning Movement Count Heavy Vehicle Summary Flow Diagram



Brisebois Crescent (West) & Centrum Boulevard Orléans, ON

Heavy Vehicles
(Construction Vehicles, Heavy Trucks, Buses & School Buses).
Heavy vehicle totals **ARE** included in the all vehicles summary and flow diagrams.

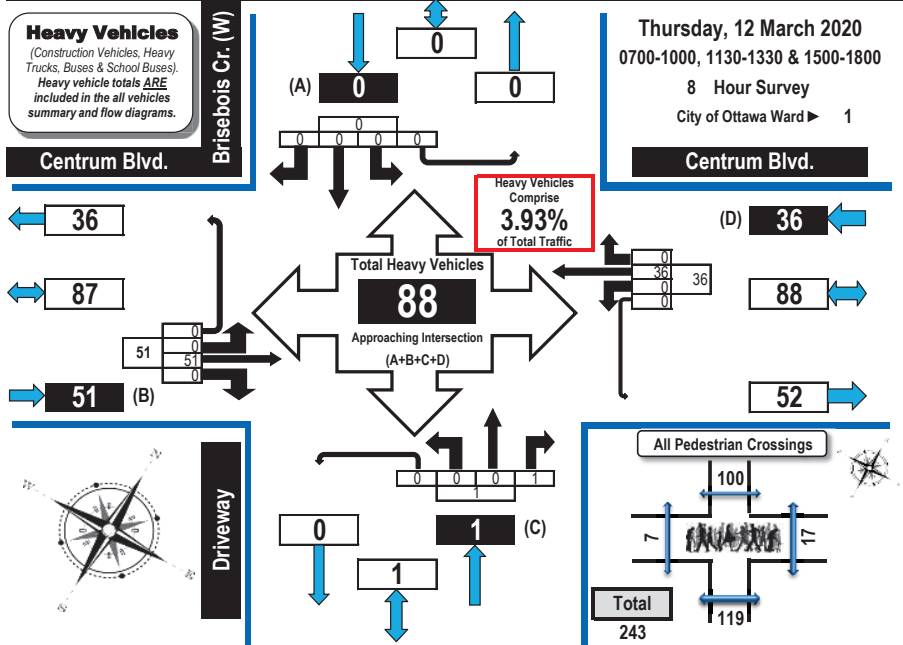

Thursday, 12 March 2020
0700-1000, 1130-1330 & 1500-1800
8 Hour Survey
City of Ottawa Ward ► 1

Time Period	Centrum Blvd. Eastbound					Centrum Blvd. Westbound					Driveway Northbound					Brisebois Cr. (W) Southbound					S. Tot	G. Tot	
	LT	ST	RT	UT	S. Tot	LT	ST	RT	UT	S. Tot	LT	ST	RT	UT	S. Tot	LT	ST	RT	UT	S. Tot			
	0700-0800	0	8	0	0	8	0	1	0	0	1	0	0	0	0	0	0	0	0	0			0
0800-0900	0	12	0	0	12	0	2	0	0	2	0	0	0	0	0	0	0	0	0	0	0	14	14
0900-1000	0	4	0	0	4	0	4	0	0	4	0	0	1	0	1	0	0	0	0	0	0	9	9
1130-1230	0	6	0	0	6	0	5	0	0	5	0	0	0	0	0	0	0	0	0	0	0	11	11
1230-1330	0	4	0	0	4	0	4	0	0	4	0	0	0	0	0	0	0	0	0	0	0	8	8
1500-1600	0	5	0	0	5	0	6	0	0	6	0	0	0	0	0	0	0	0	0	0	0	11	11
1600-1700	0	7	0	0	7	0	9	0	0	9	0	0	0	0	0	0	0	0	0	0	0	16	16
1700-1800	0	5	0	0	5	0	5	0	0	5	0	0	0	0	0	0	0	0	0	0	0	10	10
Totals	0	51	0	0	51	0	36	0	0	36	0	0	1	0	1	0	0	0	0	0	88	88	

Comments:
OC Transpo buses and school buses comprise the majority of the heavy vehicle traffic.



Turning Movement Count Pedestrian Crossings Summary and Flow Diagram



Brisebois Crescent (West) & Centrum Boulevard Orléans, ON

Pedestrian Crossings

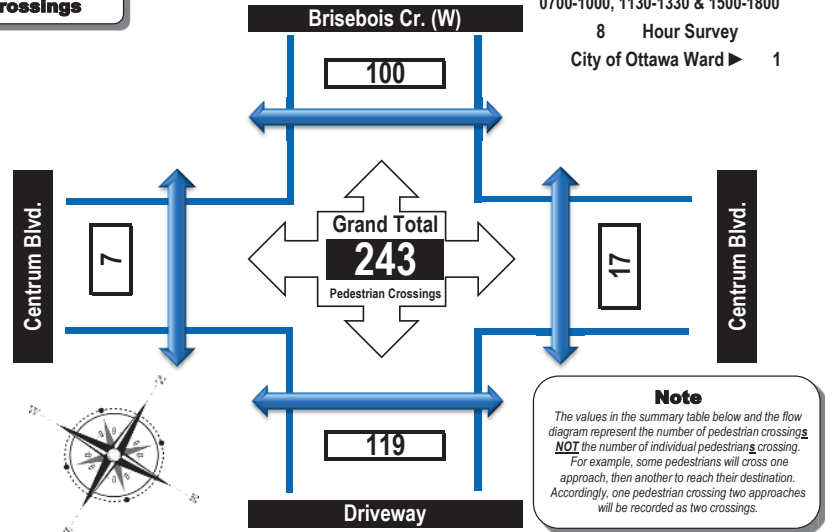

Thursday, 12 March 2020
0700-1000, 1130-1330 & 1500-1800
8 Hour Survey
City of Ottawa Ward ► 1

Note
The values in the summary table below and the flow diagram represent the number of pedestrian crossings, NOT the number of individual pedestrians crossing. For example, some pedestrians will cross one approach, then another to reach their destination. Accordingly, one pedestrian crossing two approaches will be recorded as two crossings.

Time Period	West Side Crossing Centrum Blvd.	East Side Crossing Centrum Blvd.	Street Total	South Side Crossing Driveway	North Side Crossing Brisebois Cr. (W)	Street Total	Grand Total
0700-0800	1	2	3	8	3	11	14
0800-0900	0	0	0	11	8	19	19
0900-1000	0	3	3	9	8	17	20
1130-1230	1	0	1	16	13	29	30
1230-1330	1	2	3	16	7	23	26
1500-1600	2	6	8	22	30	52	60
1600-1700	2	1	3	14	18	32	35
1700-1800	0	3	3	23	13	36	39
Totals	7	17	24	119	100	219	243

Comments:
OC Transpo buses and school buses comprise the majority of the heavy traffic.



Turning Movement Count Bicycle Summary Flow Diagram



Brisebois Crescent (West) & Centrum Boulevard Orléans, ON

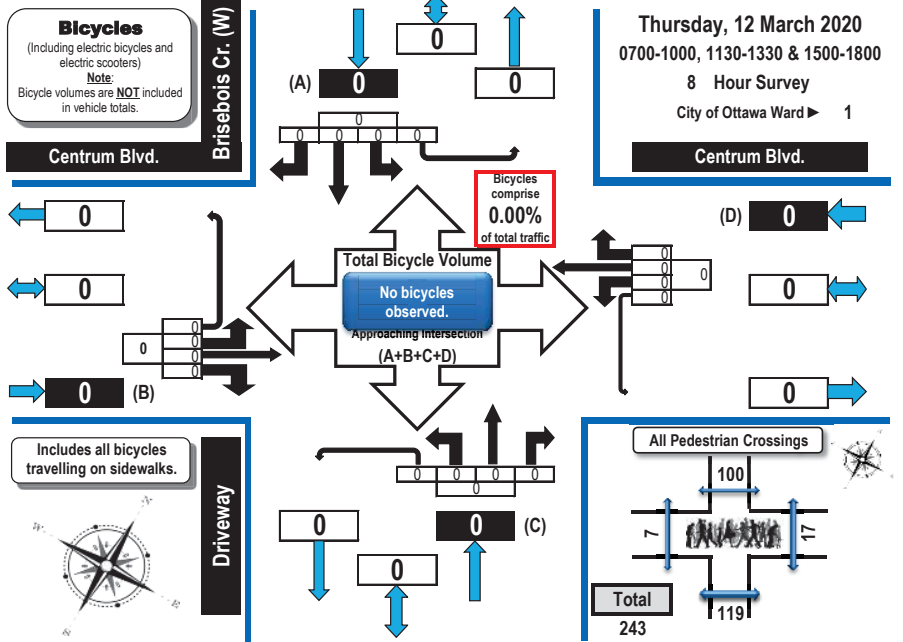

Time Period	Centrum Blvd. Eastbound					Centrum Blvd. Westbound					Driveway Northbound					Brisebois Cr. (W) Southbound					S.Tot	G.Tot
	LT	ST	RT	UT	S.Tot	LT	ST	RT	UT	S.Tot	LT	ST	RT	UT	S.Tot	LT	ST	RT	UT	S.Tot		
0700-0800	0	0	0	0	0	0	0	0	0	0	0	0	0	0	0	0	0	0	0	0	0	0
0800-0900	0	0	0	0	0	0	0	0	0	0	0	0	0	0	0	0	0	0	0	0	0	0
0900-1000	0	0	0	0	0	0	0	0	0	0	0	0	0	0	0	0	0	0	0	0	0	0
1130-1230	0	0	0	0	0	0	0	0	0	0	0	0	0	0	0	0	0	0	0	0	0	0
1230-1330	0	0	0	0	0	0	0	0	0	0	0	0	0	0	0	0	0	0	0	0	0	0
1500-1600	0	0	0	0	0	0	0	0	0	0	0	0	0	0	0	0	0	0	0	0	0	0
1600-1700	0	0	0	0	0	0	0	0	0	0	0	0	0	0	0	0	0	0	0	0	0	0
1700-1800	0	0	0	0	0	0	0	0	0	0	0	0	0	0	0	0	0	0	0	0	0	0
Totals	0	0	0	0	0	0	0	0	0	0	0	0	0	0	0	0	0	0	0	0	0	0

Comments:
 OC Transpo buses and school buses comprise the majority of the heavy vehicle traffic.



Turning Movement Count Summary Report AADT and Expansion Factors

Automobiles, Taxis,
 Light Trucks, Vans,
 SUV's, Motorcycles,
 Heavy Trucks, Buses,
 and School Buses

Brisebois Crescent (West) & Centrum Boulevard Orléans, ON

Survey Date: Thursday, 12 March 2020 Start Time: 0700 AADT Factor: 1.0
 Weather AM: Cloudy -2° C Survey Duration: 8 Hrs. Survey Hours: 0700-1000, 1130-1330 & 1500-1800
 Weather PM: Partly Cloudy +1° C Surveyor(s): T. Carmody

Time Period	Centrum Blvd. Eastbound					Centrum Blvd. Westbound					Driveway Northbound					Brisebois Cr. (W) Southbound					S/B Tot	Street Total	Grand Total
	LT	ST	RT	UT	E/B Tot	LT	ST	RT	UT	W/B Tot	LT	ST	RT	UT	N/B Tot	LT	ST	RT	UT	S.Tot			
0700-0800	30	28	0	0	58	0	56	6	0	62	120	0	1	0	0	1	2	0	19	0	21	22	142
0800-0900	29	66	10	1	106	2	95	2	0	99	205	1	0	1	0	2	0	1	23	0	24	26	231
0900-1000	24	80	10	0	114	2	124	3	0	129	243	0	0	1	0	1	1	0	13	0	14	15	258
1130-1230	16	105	11	2	134	0	90	4	0	94	228	8	0	3	0	11	1	0	38	0	39	50	278
1230-1330	31	122	16	0	169	0	123	5	0	128	297	2	0	2	0	4	1	1	23	0	25	29	326
1500-1600	23	155	8	1	187	1	113	1	0	115	302	5	0	5	0	10	3	0	28	0	31	41	343
1600-1700	16	159	2	0	177	0	94	8	0	102	279	9	0	7	0	16	7	1	38	0	46	62	341
1700-1800	28	166	7	1	202	1	87	2	1	91	293	1	0	0	0	1	1	0	27	0	28	29	322
Totals	197	881	64	5	1147	6	782	31	1	820	1967	26	1	19	0	46	16	3	209	0	228	274	2241

Equivalent 12 & 24-hour Vehicle Volumes Including the Annual Average Daily Traffic (AADT) Factor
 Applicable to the Day and Month of the Turning Movement Count
Expansion factors are applied exclusively to standard weekday 8-hour turning movement counts
conducted during the hours of 0700h - 1000h, 1130h - 1330h and 1500h - 1800h

Equivalent 12-hour vehicle volumes. These volumes are calculated by multiplying the 8-hour totals by the 8 → 12 expansion factor of 1.39																							
Equ. 12 Hr	274	1225	89	7	1594	8	1087	43	1	1140	2734	36	1	26	0	64	22	4	291	0	317	381	3115
Average daily 12-hour vehicle volumes. These volumes are calculated by multiplying the equivalent 12-hour totals by the AADT factor of: 1.0																							
AADT 12-hr	274	1225	89	7	1594	8	1087	43	1	1140	2734	36	1	26	0	64	22	4	291	0	317	381	3115
24-Hour AADT. These volumes are calculated by multiplying the average daily 12-hour vehicle volumes by the 12 → 24 expansion factor of 1.31																							
AADT 24 Hr	359	1604	117	9	2089	11	1424	56	2	1493	3582	47	2	35	0	84	29	5	381	0	415	499	4081

AADT and expansion factors provided by the City of Ottawa

AM Peak Hour Factor	→ 0.79																						
AM Peak Hr	LT	ST	RT	UT	TOT	LT	ST	RT	UT	TOT	LT	ST	RT	UT	TOT	LT	ST	RT	UT	TOT	S.TOT	G.TOT	
0900-1000	24	80	10	0	114	2	124	3	0	129	243	0	0	1	0	1	1	0	13	0	14	15	258
OFF Peak Hour Factor	→ 0.91																						
OFF Peak Hr	LT	ST	RT	UT	TOT	LT	ST	RT	UT	TOT	LT	ST	RT	UT	TOT	LT	ST	RT	UT	TOT	S.TOT	G.TOT	
1215-1315	27	128	15	1	171	0	116	6	0	122	293	3	0	1	0	4	1	1	29	0	31	35	328
PM Peak Hour Factor	→ 0.78																						
PM Peak Hr	LT	ST	RT	UT	TOT	LT	ST	RT	UT	TOT	LT	ST	RT	UT	TOT	LT	ST	RT	UT	TOT	S.TOT	G.TOT	
1515-1615	22	177	8	1	208	1	117	3	0	121	329	7	0	8	0	15	7	0	37	0	44	59	388

Comments:
 OC Transpo buses and school buses comprise the majority of the heavy vehicle traffic.

- Notes:**
- Includes all vehicle types except bicycles, electric bicycles, and electric scooters.
 - When expansion and AADT factors are applied, the results will differ slightly due to rounding.



Transportation Services - Traffic Services

Turning Movement Count - Study Results

PRESTONE DR @ ST. JOSEPH BLVD

Survey Date: Tuesday, March 20, 2018

WO No: 37614

Start Time: 07:00

Device: Miovision

Full Study Diagram

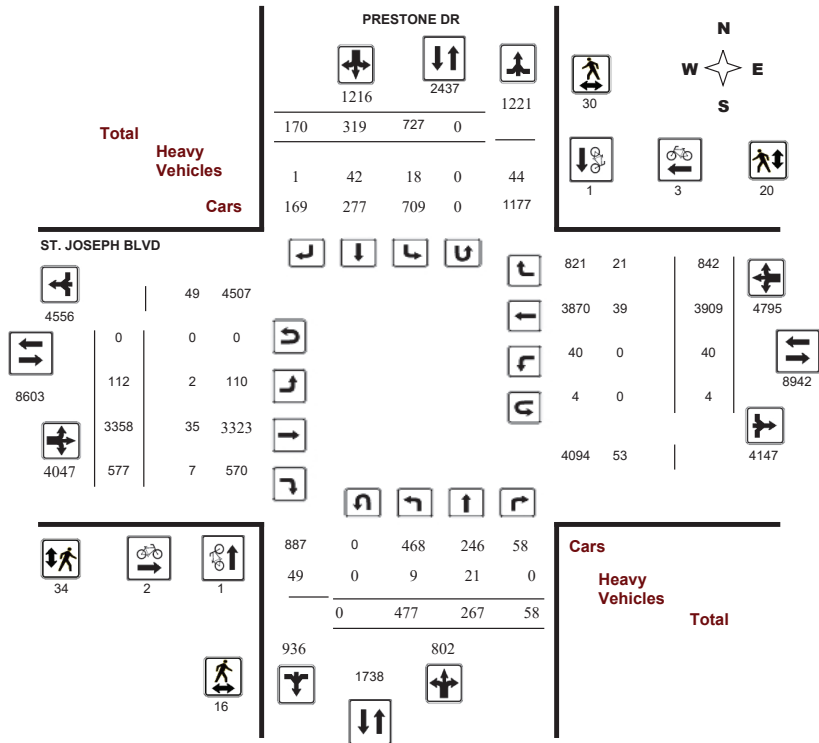

Transportation Services - Traffic Services

Turning Movement Count - Study Results

PRESTONE DR @ ST. JOSEPH BLVD

Survey Date: Tuesday, March 20, 2018

WO No: 37614

Start Time: 07:00

Device: Miovision

Full Study Peak Hour Diagram

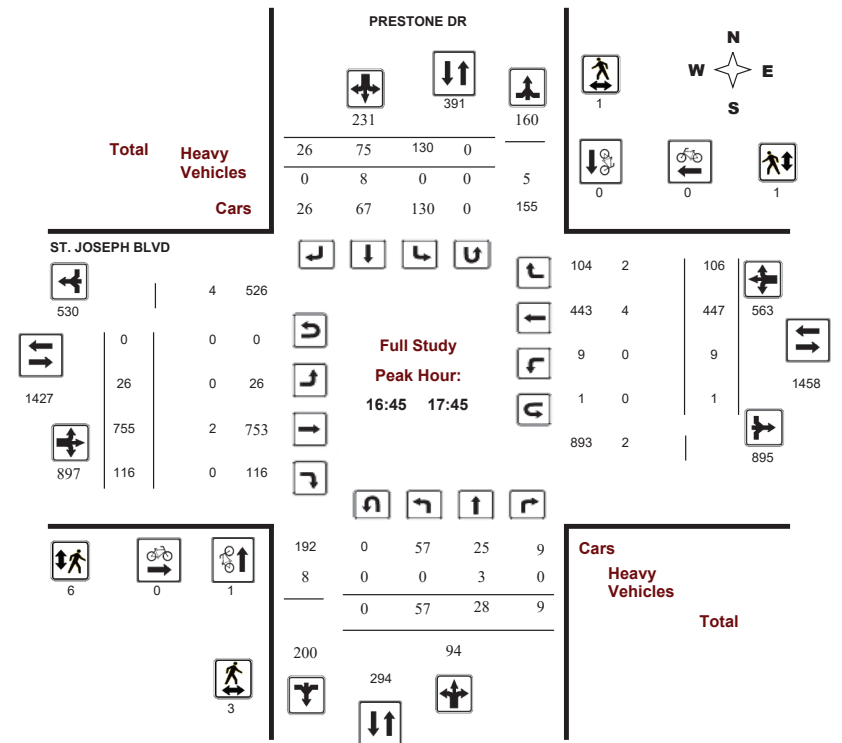



Transportation Services - Traffic Services

Turning Movement Count - Peak Hour Diagram

PRESTONE DR @ ST. JOSEPH BLVD

Survey Date: Tuesday, March 20, 2018
Start Time: 07:00

WO No: 37614
Device: Miovision

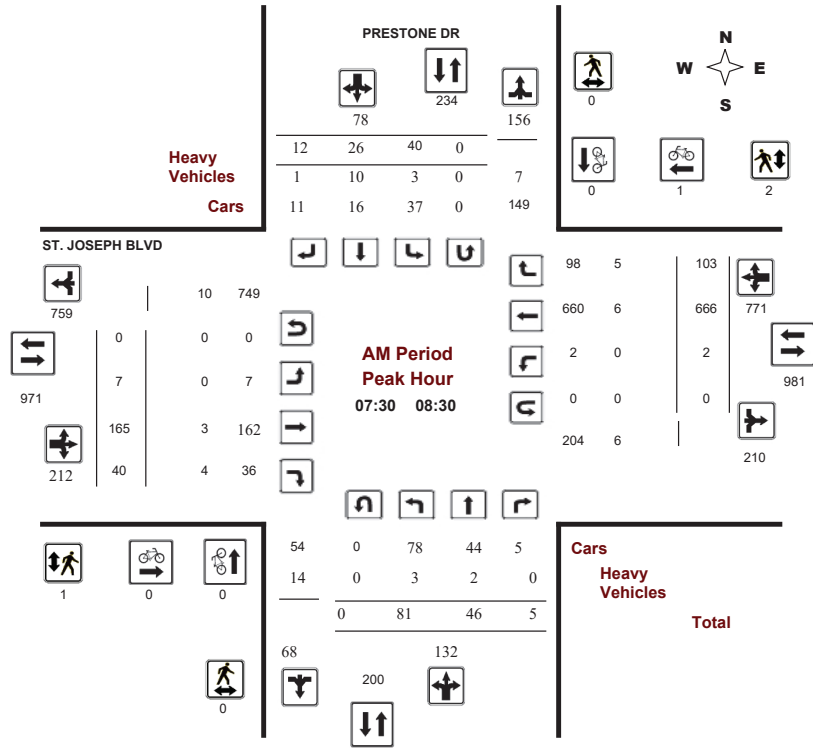

Transportation Services - Traffic Services

Turning Movement Count - Peak Hour Diagram

PRESTONE DR @ ST. JOSEPH BLVD

Survey Date: Tuesday, March 20, 2018
Start Time: 07:00

WO No: 37614
Device: Miovision

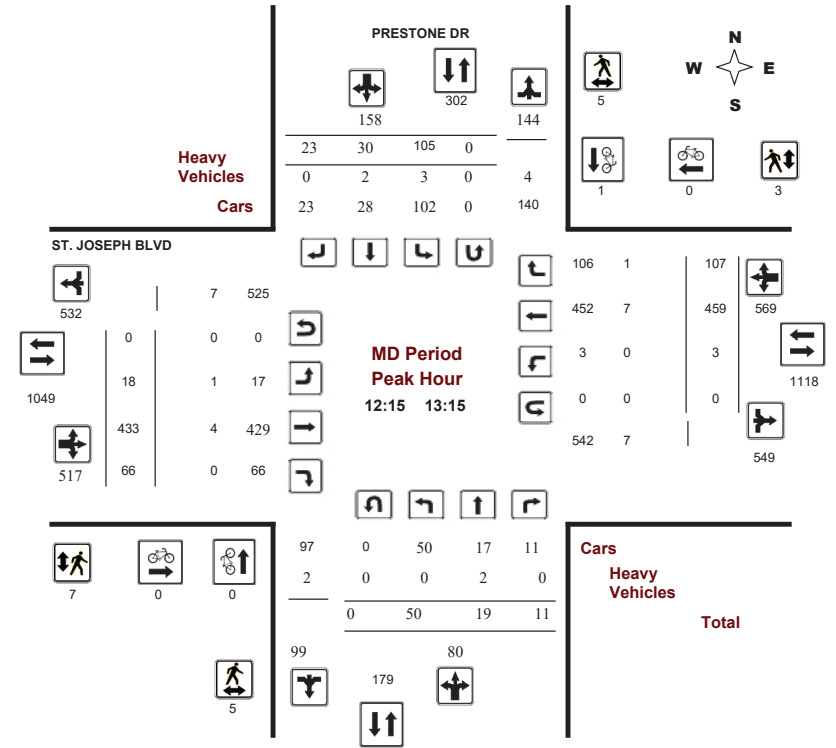



Transportation Services - Traffic Services

Turning Movement Count - Peak Hour Diagram

PRESTONE DR @ ST. JOSEPH BLVD

Survey Date: Tuesday, March 20, 2018

Start Time: 07:00

WO No: 37614

Device: Miovision

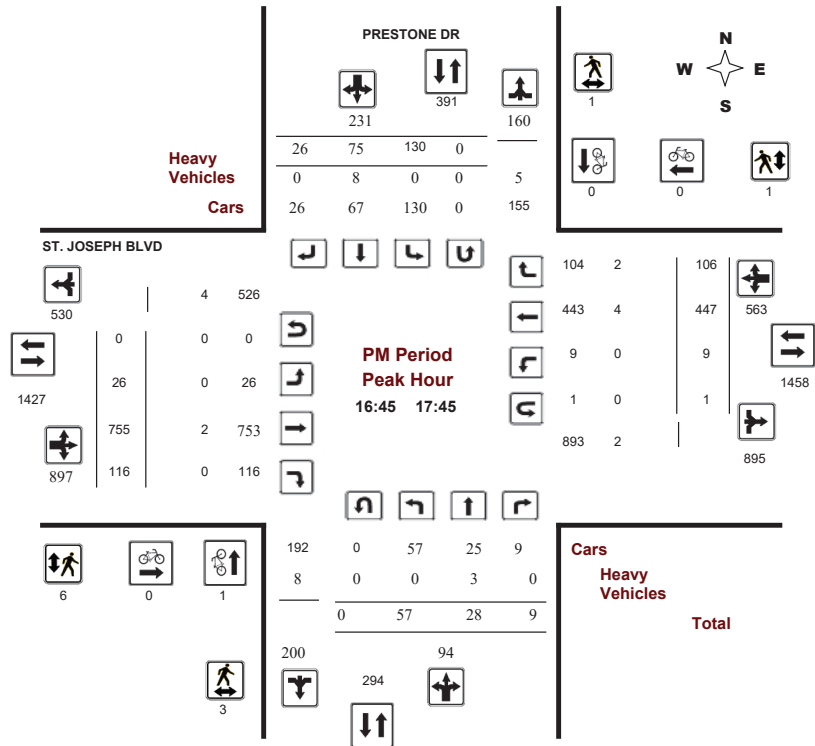

Comments



Transportation Services - Traffic Services

Turning Movement Count - Study Results

PRESTONE DR @ ST. JOSEPH BLVD

Survey Date: Tuesday, March 20, 2018

Start Time: 07:00

WO No: 37614

Device: Miovision

Full Study Summary (8 HR Standard)

Survey Date: Tuesday, March 20, 2018

Total Observed U-Turns

Northbound: 0 Southbound: 0
 Eastbound: 0 Westbound: 4

AADT Factor

1.39

Period	PRESTONE DR								ST. JOSEPH BLVD								WB TOT	STR TOT	Grand Total			
	Northbound				Southbound				Eastbound				Westbound									
	LT	ST	RT	NB TOT	LT	ST	RT	SB TOT	LT	ST	RT	EB TOT	LT	ST	RT	WB TOT						
07:00-08:00	101	45	4	150	40	14	16	70	220	6	126	26	158	1	676	83	760	918	1138			
08:00-09:00	69	46	5	120	38	32	14	84	204	9	187	33	229	2	573	130	705	934	1138			
09:00-10:00	55	36	7	98	50	27	20	97	195	10	232	34	276	3	437	104	544	820	1015			
11:30-12:30	55	31	7	93	110	35	28	173	266	2	401	77	480	7	442	104	553	1033	1299			
12:30-13:30	55	17	13	85	91	28	25	144	229	22	422	54	498	3	463	107	573	1071	1300			
15:00-16:00	42	30	6	78	118	48	22	188	266	23	562	111	696	7	441	92	540	1236	1502			
16:00-17:00	44	29	4	77	157	71	24	252	329	16	712	127	855	10	416	111	537	1392	1721			
17:00-18:00	56	33	12	101	123	64	21	208	309	24	716	115	855	7	461	111	579	1434	1743			
Sub Total	477	267	58	802	727	319	170	1216	2018	112	3358	577	4047	40	3909	842	4791	8838	10856			
U Turns	0								0								4				4	4
Total	477	267	58	802	727	319	170	1216	2018	112	3358	577	4047	40	3909	842	4795	8842	10860			
EQ 12Hr	663	371	81	1115	1011	443	236	1690	2805	156	4668	802	5625	56	5434	1170	6665	12290	15095			
Note: These values are calculated by multiplying the totals by the appropriate expansion factor.														1.39								
AVG 12Hr	663	371	81	1115	1011	443	236	1690	2805	156	4668	802	5625	56	5434	1170	6665	12290	15095			
Note: These volumes are calculated by multiplying the Equivalent 12 hr. totals by the AADT factor.														1								
AVG 24Hr	869	486	106	1460	1324	581	310	2214	3674	204	6115	1051	7369	73	7118	1533	8731	16100	19774			
Note: These volumes are calculated by multiplying the Average Daily 12 hr. totals by 12 to 24 expansion factor.														1.31								
Note: U-Turns provided for approach totals. Refer to 'U-Turn' Report for specific breakdown.																						



Transportation Services - Traffic Services

Turning Movement Count - Study Results

PRESTONE DR @ ST. JOSEPH BLVD

Survey Date: Tuesday, March 20, 2018

WO No: 37614

Start Time: 07:00

Device: Miovision

Full Study 15 Minute Increments

PRESTONE DR ST. JOSEPH BLVD

Table with columns for Time Period, Northbound (LT, ST, RT, N TOT, STR TOT), Southbound (LT, ST, RT, S TOT, STR TOT), Eastbound (LT, ST, RT, E TOT), Westbound (LT, ST, RT, W TOT, STR TOT), and Grand Total. Rows represent 15-minute intervals from 07:00 to 18:00.

Note: U-Turns are included in Totals.



Transportation Services - Traffic Services

Turning Movement Count - Study Results

PRESTONE DR @ ST. JOSEPH BLVD

Survey Date: Tuesday, March 20, 2018

WO No: 37614

Start Time: 07:00

Device: Miovision

Full Study Cyclist Volume

PRESTONE DR ST. JOSEPH BLVD

Table with columns for Time Period, Northbound, Southbound, Street Total, Eastbound, Westbound, Street Total, and Grand Total. Rows represent 15-minute intervals from 07:00 to 18:00.



Transportation Services - Traffic Services

Turning Movement Count - Study Results

PRESTONE DR @ ST. JOSEPH BLVD

Survey Date: Tuesday, March 20, 2018

WO No: 37614

Start Time: 07:00

Device: Miovision

Full Study Pedestrian Volume

PRESTONE DR

ST. JOSEPH BLVD

Table with columns: Time Period, NB Approach, SB Approach, Total, EB Approach, WB Approach, Grand Total. Rows show pedestrian counts from 07:00 to 18:00.



Transportation Services - Traffic Services

Turning Movement Count - Study Results

PRESTONE DR @ ST. JOSEPH BLVD

Survey Date: Tuesday, March 20, 2018

WO No: 37614

Start Time: 07:00

Device: Miovision

Full Study Heavy Vehicles

PRESTONE DR

ST. JOSEPH BLVD

Table with columns: Time Period, Northbound (LT, ST, RT, N TOT, STR TOT), Southbound (LT, ST, RT, S TOT, STR TOT), Eastbound (LT, ST, RT, E TOT, W TOT), Westbound (LT, ST, RT, W TOT, STR TOT), Grand Total. Rows show heavy vehicle counts from 07:00 to 18:00.



Transportation Services - Traffic Services

Turning Movement Count - Study Results

PRESTONE DR @ ST. JOSEPH BLVD

Survey Date: Tuesday, March 20, 2018

WO No: 37614

Start Time: 07:00

Device: Miovision

Full Study 15 Minute U-Turn Total

PRESTONE DR

ST. JOSEPH BLVD

Time Period	Northbound U-Turn Total	Southbound U-Turn Total	Eastbound U-Turn Total	Westbound U-Turn Total	Total
07:00 07:15	0	0	0	0	0
07:15 07:30	0	0	0	0	0
07:30 07:45	0	0	0	0	0
07:45 08:00	0	0	0	0	0
08:00 08:15	0	0	0	0	0
08:15 08:30	0	0	0	0	0
08:30 08:45	0	0	0	0	0
08:45 09:00	0	0	0	0	0
09:00 09:15	0	0	0	1	1
09:15 09:30	0	0	0	0	0
09:30 09:45	0	0	0	0	0
09:45 10:00	0	0	0	0	0
11:30 11:45	0	0	0	0	0
11:45 12:00	0	0	0	0	0
12:00 12:15	0	0	0	0	0
12:15 12:30	0	0	0	0	0
12:30 12:45	0	0	0	0	0
12:45 13:00	0	0	0	0	0
13:00 13:15	0	0	0	0	0
13:15 13:30	0	0	0	0	0
15:00 15:15	0	0	0	0	0
15:15 15:30	0	0	0	0	0
15:30 15:45	0	0	0	0	0
15:45 16:00	0	0	0	1	1
16:00 16:15	0	0	0	0	0
16:15 16:30	0	0	0	0	0
16:30 16:45	0	0	0	1	1
16:45 17:00	0	0	0	0	0
17:00 17:15	0	0	0	0	0
17:15 17:30	0	0	0	1	1
17:30 17:45	0	0	0	0	0
17:45 18:00	0	0	0	0	0
Total	0	0	0	4	4

Appendix C

Synchro Intersection Worksheets – Existing Conditions

Lanes, Volumes, Timings
1: Place d'Orleans & Centrum

AM Peak Hour
Existing

Lane Group	EBL	EBT	EBR	WBL	WBT	WBR	NBL	NBT	NBR	SBL	SBT	SBR
Lane Configurations	↔	↔	↔	↔	↔	↔	↔	↔	↔	↔	↔	↔
Traffic Volume (vph)	25	30	40	22	32	1	67	144	52	110	42	19
Future Volume (vph)	25	30	40	22	32	1	67	144	52	110	42	19
Satd. Flow (prot)	1566	1745	1401	1658	1721	0	0	3141	0	0	3025	0
Fit Permitted	0.733			0.736				0.840			0.682	
Satd. Flow (perm)	1200	1745	1375	1277	1721	0	0	2672	0	0	2129	0
Satd. Flow (RTOR)			44		1			57			21	
Lane Group Flow (vph)	28	33	44	24	37	0	0	292	0	0	190	0
Turn Type	Perm	NA	Perm	Perm	NA	Perm	NA	Perm	NA	Perm	NA	
Protected Phases	4			8			2	2		6		6
Permitted Phases	4		4	8			2			6		6
Detector Phase	4	4	4	8	8		2	2		6	6	
Switch Phase												
Minimum Initial (s)	10.0	10.0	10.0	10.0	10.0		10.0	10.0		10.0	10.0	
Minimum Split (s)	31.0	31.0	31.0	31.0	31.0		36.0	36.0		36.0	36.0	
Total Split (s)	32.0	32.0	32.0	32.0	32.0		43.0	43.0		43.0	43.0	
Total Split (%)	42.7%	42.7%	42.7%	42.7%	42.7%		57.3%	57.3%		57.3%	57.3%	
Yellow Time (s)	3.3	3.3	3.3	3.3	3.3		3.3	3.3		3.3	3.3	
All-Red Time (s)	2.7	2.7	2.7	2.7	2.7		2.7	2.7		2.7	2.7	
Lost Time Adjust (s)	0.0	0.0	0.0	0.0	0.0		0.0	0.0		0.0	0.0	
Total Lost Time (s)	6.0	6.0	6.0	6.0	6.0		6.0	6.0		6.0	6.0	
Lead/Lag												
Lead-Lag Optimize?												
Recall Mode	None	None	None	None	None		Max	Max		Max	Max	
Act Effct Green (s)	12.6	12.6	12.6	12.6	12.6		46.3	46.3		46.3	46.3	
Actuated g/C Ratio	0.20	0.20	0.20	0.20	0.20		0.75	0.75		0.75	0.75	
v/c Ratio	0.11	0.09	0.14	0.09	0.11		0.14	0.11		0.12	0.11	
Control Delay	20.2	19.6	7.6	19.7	19.4		4.8	5.4		5.4	5.4	
Queue Delay	0.0	0.0	0.0	0.0	0.0		0.0	0.0		0.0	0.0	
Total Delay	20.2	19.6	7.6	19.7	19.4		4.8	5.4		5.4	5.4	
LOS	C	B	A	B	B		A	A		A	A	
Approach Delay		14.7			19.5		4.8	5.4		5.4	5.4	
Approach LOS		B			B		A	A		A	A	
Queue Length 50th (m)	2.6	3.1	0.0	2.2	3.4		4.5	3.2		3.2	3.2	
Queue Length 95th (m)	7.8	8.5	6.1	7.0	9.1		15.3	11.6		11.6	11.6	
Internal Link Dist (m)		55.7			119.8		103.0	90.8		90.8	90.8	
Turn Bay Length (m)	52.0		20.0									
Base Capacity (vph)	510	743	610	543	733		2020	1603		1603	1603	
Starvation Cap Reductn	0	0	0	0	0		0	0		0	0	
Spillback Cap Reductn	0	0	0	0	0		0	0		0	0	
Storage Cap Reductn	0	0	0	0	0		0	0		0	0	
Reduced v/c Ratio	0.05	0.04	0.07	0.04	0.05		0.14	0.12		0.12	0.12	

Intersection Summary

Cycle Length: 75
Actuated Cycle Length: 61.6
Natural Cycle: 70
Control Type: Actuated-Uncoordinated
Maximum v/c Ratio: 0.14

Lanes, Volumes, Timings
1: Place d'Orleans & Centrum

AM Peak Hour
Existing

Intersection Signal Delay: 8.0
Intersection Capacity Utilization 59.6%
Analysis Period (min) 15
Intersection LOS: A
ICU Level of Service B

Splits and Phases: 1: Place d'Orleans & Centrum



HCM 2010 TWSC
2: Centrum & Brisebois W

AM Peak Hour
Existing

Intersection												
Int Delay, s/veh	1.3											
Movement	EBL	EBT	EBR	WBL	WBT	WBR	NBL	NBT	NBR	SBL	SBT	SBR
Lane Configurations	↔			↔			↔			↔		
Traffic Vol, veh/h	24	80	10	2	124	3	0	0	1	1	0	13
Future Vol, veh/h	24	80	10	2	124	3	0	0	1	1	0	13
Conflicting Peds, #/hr	8	0	9	9	0	8	0	0	3	3	0	0
Sign Control	Free	Free	Free	Free	Free	Free	Stop	Stop	Stop	Stop	Stop	Stop
RT Channelized	-	-	None	-	-	None	-	-	None	-	-	None
Storage Length	-	-	-	-	-	-	-	-	-	-	-	-
Veh in Median Storage, #	-	0	-	-	0	-	-	0	-	-	0	-
Grade, %	-	0	-	-	0	-	-	0	-	-	0	-
Peak Hour Factor	90	90	90	90	90	90	90	90	90	90	90	90
Heavy Vehicles, %	2	5	2	2	3	2	2	2	100	2	2	2
Mvmt Flow	27	89	11	2	138	3	0	0	1	1	0	14
Major/Minor	Major1	Major2			Minor1			Minor2				
Conflicting Flow All	149	0	0	109	0	0	309	311	107	304	315	148
Stage 1	-	-	-	-	-	-	158	158	-	152	152	-
Stage 2	-	-	-	-	-	-	151	153	-	152	163	-
Critical Hdwy	4.12	-	-	4.12	-	-	7.12	6.52	7.2	7.12	6.52	6.22
Critical Hdwy Stg 1	-	-	-	-	-	-	6.12	5.52	-	6.12	5.52	-
Critical Hdwy Stg 2	-	-	-	-	-	-	6.12	5.52	-	6.12	5.52	-
Follow-up Hdwy	2.218	-	-	2.218	-	-	3.518	4.018	4.2	3.518	4.018	3.318
Pot Cap-1 Maneuver	1432	-	-	1481	-	-	643	604	736	648	601	899
Stage 1	-	-	-	-	-	-	844	767	-	850	772	-
Stage 2	-	-	-	-	-	-	851	771	-	850	763	-
Platoon blocked, %	-	-	-	-	-	-	-	-	-	-	-	-
Mov Cap-1 Maneuver	1423	-	-	1471	-	-	618	583	729	631	581	893
Mov Cap-2 Maneuver	-	-	-	-	-	-	618	583	-	631	581	-
Stage 1	-	-	-	-	-	-	821	746	-	828	767	-
Stage 2	-	-	-	-	-	-	836	766	-	830	742	-
Approach	EB	WB			NB			SB				
HCM Control Delay, s	1.6	0.1			9.9			9.2				
HCM LOS	A			A			A					
Minor Lane/Major Mvmt	NBLn1	EBL	EBT	EBR	WBL	WBT	WBR	SBLn1				
Capacity (veh/h)	729	1423	-	-	1471	-	-	867				
HCM Lane V/C Ratio	0.002	0.019	-	-	0.002	-	-	0.018				
HCM Control Delay (s)	9.9	7.6	0	-	7.5	0	-	9.2				
HCM Lane LOS	A	A	A	-	A	A	-	A				
HCM 95th %tile Q(veh)	0	0.1	-	-	0	-	-	0.1				

HCM 2010 AWSC
3: Prestone & Centrum

AM Peak Hour
Existing

Intersection						
Intersection Delay, s/veh	7.7					
Intersection LOS	A					
Movement	EBT	EBR	WBL	WBT	NBL	NBR
Lane Configurations	↔			↔	↔	↔
Traffic Vol, veh/h	20	41	39	18	55	36
Future Vol, veh/h	20	41	39	18	55	36
Peak Hour Factor	0.90	0.90	0.90	0.90	0.90	0.90
Heavy Vehicles, %	5	17	2	6	7	2
Mvmt Flow	22	46	43	20	61	40
Number of Lanes	1	0	0	1	1	1
Approach	EB	WB		NB		
Opposing Approach	WB	EB				
Opposing Lanes	1	1		0		
Conflicting Approach Left		NB		EB		
Conflicting Lanes Left	0	2		1		
Conflicting Approach Right	NB			WB		
Conflicting Lanes Right	2	0		1		
HCM Control Delay	7.2	7.8		8		
HCM LOS	A	A		A		
Lane	NBLn1	NBLn2	EBLn1	WBLn1		
Vol Left, %	100%	0%	0%	68%		
Vol Thru, %	0%	0%	33%	32%		
Vol Right, %	0%	100%	67%	0%		
Sign Control	Stop	Stop	Stop	Stop		
Traffic Vol by Lane	55	36	61	57		
LT Vol	55	0	0	39		
Through Vol	0	0	20	18		
RT Vol	0	36	41	0		
Lane Flow Rate	61	40	68	63		
Geometry Grp	7	7	2	2		
Degree of Util (X)	0.091	0.045	0.074	0.076		
Departure Headway (Hd)	5.345	4.058	3.906	4.295		
Convergence, Y/N	Yes	Yes	Yes	Yes		
Cap	666	874	922	820		
Service Time	3.111	1.823	1.906	2.394		
HCM Lane V/C Ratio	0.092	0.046	0.074	0.077		
HCM Control Delay	8.7	7	7.2	7.8		
HCM Lane LOS	A	A	A	A		
HCM 95th %tile Q	0.3	0.1	0.2	0.2		

HCM 2010 TWSC
4: Centrum & Brisebois E

AM Peak Hour
Existing

Intersection						
Int Delay, s/veh	2					
Movement	EBL	EBT	WBT	WBR	SBL	SBR
Lane Configurations		↕	↕		↕	↕
Traffic Vol, veh/h	11	19	26	1	0	5
Future Vol, veh/h	11	19	26	1	0	5
Conflicting Peds, #/hr	0	0	0	0	0	0
Sign Control	Free	Free	Free	Free	Stop	Stop
RT Channelized	-	None	-	None	-	None
Storage Length	-	-	-	-	0	-
Veh in Median Storage, #	-	0	0	-	0	-
Grade, %	-	0	0	-	0	-
Peak Hour Factor	90	90	90	90	90	90
Heavy Vehicles, %	9	2	2	2	2	20
Mvmt Flow	12	21	29	1	0	6
Major/Minor	Major1	Major2	Minor2			
Conflicting Flow All	30	0	0	75	30	
Stage 1	-	-	-	30	-	
Stage 2	-	-	-	45	-	
Critical Hdwy	4.19	-	-	6.42	6.4	
Critical Hdwy Stg 1	-	-	-	5.42	-	
Critical Hdwy Stg 2	-	-	-	5.42	-	
Follow-up Hdwy	2.281	-	-	3.518	3.48	
Pot Cap-1 Maneuver	1539	-	-	928	995	
Stage 1	-	-	-	993	-	
Stage 2	-	-	-	977	-	
Platoon blocked, %	-	-	-	-	-	
Mov Cap-1 Maneuver	1539	-	-	921	995	
Mov Cap-2 Maneuver	-	-	-	921	-	
Stage 1	-	-	-	985	-	
Stage 2	-	-	-	977	-	
Approach	EB	WB	SB			
HCM Control Delay, s	2.7	0	8.6			
HCM LOS			A			
Minor Lane/Major Mvmt	EBL	EBT	WBT	WBR	SBLn1	
Capacity (veh/h)	1539	-	-	-	995	
HCM Lane V/C Ratio	0.008	-	-	-	0.006	
HCM Control Delay (s)	7.4	0	-	-	8.6	
HCM Lane LOS	A	A	-	-	A	
HCM 95th %tile Q(veh)	0	-	-	-	0	

Lanes, Volumes, Timings
5: Prestone & St Joseph

AM Peak Hour
Existing

Lane Group	EBL	EBT	EBR	WBL	WBT	WBR	NBL	NBT	NBR	SBL	SBT	SBR
Lane Configurations	↕	↕	↕	↕	↕	↕	↕	↕	↕	↕	↕	↕
Traffic Volume (vph)	7	165	40	2	666	103	81	46	5	40	26	12
Future Volume (vph)	7	165	40	2	666	103	81	46	5	40	26	12
Satd. Flow (prot)	1658	3316	1375	1658	3316	1441	1626	1685	0	1566	1314	0
Fit Permitted	0.288			0.636			0.730			0.720		
Satd. Flow (perm)	503	3316	1375	1110	3316	1423	1248	1685	0	1184	1314	0
Satd. Flow (RTOR)			44			114		6			13	
Lane Group Flow (vph)	8	183	44	2	740	114	90	57	0	44	42	0
Turn Type	Perm	NA	Perm	Perm	NA	Perm	Perm	NA		Perm	NA	
Protected Phases		2			6			8			4	
Permitted Phases	2		2	6		6	8			4		
Detector Phase	2	2	2	6	6	6	8	8		4	4	
Switch Phase												
Minimum Initial (s)	10.0	10.0	10.0	10.0	10.0	10.0	10.0	10.0		10.0	10.0	
Minimum Split (s)	23.7	23.7	23.7	23.7	23.7	23.7	29.0	29.0		29.0	29.0	
Total Split (s)	51.0	51.0	51.0	51.0	51.0	51.0	29.0	29.0		29.0	29.0	
Total Split (%)	63.8%	63.8%	63.8%	63.8%	63.8%	63.8%	36.3%	36.3%		36.3%	36.3%	
Yellow Time (s)	3.3	3.3	3.3	3.3	3.3	3.3	3.3	3.3		3.3	3.3	
All-Red Time (s)	2.4	2.4	2.4	2.4	2.4	2.4	2.7	2.7		2.7	2.7	
Lost Time Adjust (s)	0.0	0.0	0.0	0.0	0.0	0.0	0.0	0.0		0.0	0.0	
Total Lost Time (s)	5.7	5.7	5.7	5.7	5.7	5.7	6.0	6.0		6.0	6.0	
Lead/Lag												
Lead-Lag Optimize?												
Recall Mode	None	None	None	None	None	None	Max	Max		Max	Max	
Act Effct Green (s)	17.5	17.5	17.5	17.5	17.5	17.5	23.1	23.1		23.1	23.1	
Actuated g/C Ratio	0.33	0.33	0.33	0.33	0.33	0.33	0.44	0.44		0.44	0.44	
v/c Ratio	0.05	0.17	0.09	0.01	0.67	0.21	0.16	0.08		0.08	0.07	
Control Delay	11.9	12.2	4.7	11.0	18.0	3.9	11.3	9.6		10.7	8.3	
Queue Delay	0.0	0.0	0.0	0.0	0.0	0.0	0.0	0.0		0.0	0.0	
Total Delay	11.9	12.2	4.7	11.0	18.0	3.9	11.3	9.6		10.7	8.3	
LOS	B	B	A	B	B	A	B	A		B	A	
Approach Delay		10.8			16.1			10.6			9.5	
Approach LOS		B			B			B			A	
Queue Length 50th (m)	0.5	6.2	0.0	0.1	30.3	0.0	4.7	2.6		2.2	1.4	
Queue Length 95th (m)	2.6	11.3	4.7	1.1	44.4	7.4	14.1	9.0		8.2	6.8	
Internal Link Dist (m)		163.5			149.6			92.4			92.1	
Turn Bay Length (m)	50.0		105.0	62.5		120.0	47.5					
Base Capacity (vph)	437	2883	1201	965	2883	1252	550	747		522	587	
Starvation Cap Reductn	0	0	0	0	0	0	0	0		0	0	
Spillback Cap Reductn	0	0	0	0	0	0	0	0		0	0	
Storage Cap Reductn	0	0	0	0	0	0	0	0		0	0	
Reduced v/c Ratio	0.02	0.06	0.04	0.00	0.26	0.09	0.16	0.08		0.08	0.07	

Intersection Summary												
Cycle Length: 80												
Actuated Cycle Length: 52.4												
Natural Cycle: 55												
Control Type: Actuated-Uncoordinated												
Maximum v/c Ratio: 0.67												

Lanes, Volumes, Timings
5: Prestone & St Joseph

AM Peak Hour
Existing

Intersection Signal Delay: 14.1	Intersection LOS: B
Intersection Capacity Utilization 50.3%	ICU Level of Service A
Analysis Period (min) 15	

Splits and Phases: 5: Prestone & St Joseph

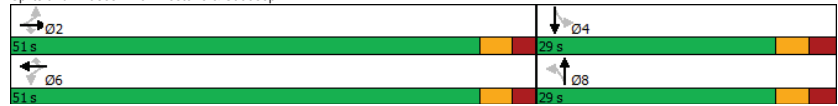

Lanes, Volumes, Timings
1: Place d'Orleans & Centrum

PM Peak Hour
Existing

Lane Group	EBL	EBT	EBR	WBL	WBT	WBR	NBL	NBT	NBR	SBL	SBT	SBR
Lane Configurations	↔	↕	↗	↖	↗	↖	↕	↕	↗	↖	↕	↕
Traffic Volume (vph)	94	56	220	41	45	0	102	153	65	108	130	42
Future Volume (vph)	94	56	220	41	45	0	102	153	65	108	130	42
Satd. Flow (prot)	1658	1745	1483	1658	1745	0	0	3104	0	0	3100	0
Fit Permitted	0.724			0.717				0.751			0.711	
Satd. Flow (perm)	1247	1745	1448	1237	1745	0	0	2366	0	0	2243	0
Satd. Flow (RTOR)			244					59			38	
Lane Group Flow (vph)	104	62	244	46	50	0	0	355	0	0	311	0
Turn Type	Perm	NA	Perm	Perm	NA		Perm	NA		Perm	NA	
Protected Phases		4			8			2			6	
Permitted Phases	4		4	8			2			6		
Detector Phase	4	4	4	8	8		2	2		6	6	
Switch Phase												
Minimum Initial (s)	10.0	10.0	10.0	10.0	10.0		10.0	10.0		10.0	10.0	
Minimum Split (s)	31.0	31.0	31.0	31.0	31.0		36.0	36.0		36.0	36.0	
Total Split (s)	32.0	32.0	32.0	32.0	32.0		53.0	53.0		53.0	53.0	
Total Split (%)	37.6%	37.6%	37.6%	37.6%	37.6%		62.4%	62.4%		62.4%	62.4%	
Yellow Time (s)	3.3	3.3	3.3	3.3	3.3		3.3	3.3		3.3	3.3	
All-Red Time (s)	2.7	2.7	2.7	2.7	2.7		2.7	2.7		2.7	2.7	
Lost Time Adjust (s)	0.0	0.0	0.0	0.0	0.0		0.0	0.0		0.0	0.0	
Total Lost Time (s)	6.0	6.0	6.0	6.0	6.0		6.0	6.0		6.0	6.0	
Lead/Lag												
Lead-Lag Optimize?												
Recall Mode	None	None	None	None	None		C-Max	C-Max		C-Max	C-Max	
Act Effct Green (s)	14.4	14.4	14.4	14.4	14.4		58.6	58.6		58.6	58.6	
Actuated g/C Ratio	0.17	0.17	0.17	0.17	0.17		0.69	0.69		0.69	0.69	
v/c Ratio	0.49	0.21	0.54	0.22	0.17		0.22	0.20		0.20	0.20	
Control Delay	38.4	29.7	8.5	30.4	28.9		5.2	5.4		5.4	5.4	
Queue Delay	0.0	0.0	0.0	0.0	0.0		0.0	0.0		0.0	0.0	
Total Delay	38.4	29.7	8.5	30.4	28.9		5.2	5.4		5.4	5.4	
LOS	D	C	A	C	C		A	A		A	A	
Approach Delay		19.3			29.6		5.2	5.4		5.4	5.4	
Approach LOS		B			C		A	A		A	A	
Queue Length 50th (m)	16.0	9.0	0.0	6.7	7.3		6.9	6.3		6.3	6.3	
Queue Length 95th (m)	25.9	16.1	15.7	13.3	13.8		18.7	17.4		17.4	17.4	
Internal Link Dist (m)		55.7			119.8		103.0	90.8		90.8	90.8	
Turn Bay Length (m)	52.0		20.0									
Base Capacity (vph)	381	533	612	378	533		1648	1557		1557	1557	
Starvation Cap Reductn	0	0	0	0	0		0	0		0	0	
Spillback Cap Reductn	0	0	0	0	0		0	0		0	0	
Storage Cap Reductn	0	0	0	0	0		0	0		0	0	
Reduced v/c Ratio	0.27	0.12	0.40	0.12	0.09		0.22	0.20		0.20	0.20	

Intersection Summary

Cycle Length: 85
Actuated Cycle Length: 85
Offset: 0 (0%), Referenced to phase 2:NBTL and 6:SBTL, Start of Green
Natural Cycle: 70
Control Type: Actuated-Coordinated

Lanes, Volumes, Timings
1: Place d'Orleans & Centrum

PM Peak Hour
Existing

Maximum v/c Ratio: 0.54	Intersection LOS: B
Intersection Signal Delay: 12.2	ICU Level of Service D
Intersection Capacity Utilization 80.0%	
Analysis Period (min) 15	

Splits and Phases: 1: Place d'Orleans & Centrum

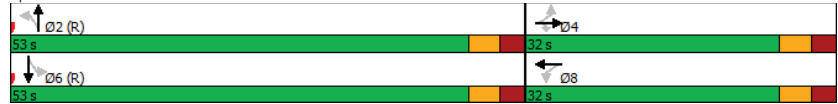

HCM 2010 TWSC
2: Centrum & Brisebois W

PM Peak Hour
Existing

Intersection												
Int Delay, s/veh 2												
Movement	EBL	EBT	EBR	WBL	WBT	WBR	NBL	NBT	NBR	SBL	SBT	SBR
Lane Configurations	↔			↔			↕			↕		
Traffic Vol, veh/h	23	177	8	1	117	3	7	0	8	7	0	37
Future Vol, veh/h	23	177	8	1	117	3	7	0	8	7	0	37
Conflicting Peds, #/hr	23	0	19	19	0	23	3	0	6	6	0	3
Sign Control	Free	Free	Free	Free	Free	Free	Stop	Stop	Stop	Stop	Stop	Stop
RT Channelized	-	-	None	-	-	None	-	-	None	-	-	None
Storage Length	-	-	-	-	-	-	-	-	-	-	-	-
Veh in Median Storage, #	-	0	-	-	0	-	-	0	-	-	0	-
Grade, %	-	0	-	-	0	-	-	0	-	-	0	-
Peak Hour Factor	90	90	90	90	90	90	90	90	90	90	90	90
Heavy Vehicles, %	2	3	2	2	5	2	2	2	2	2	2	2
Mvmt Flow	26	197	9	1	130	3	8	0	9	8	0	41
Major/Minor	Major1			Major2			Minor1			Minor2		
Conflicting Flow All	156	0	0	225	0	0	430	431	227	421	434	158
Stage 1	-	-	-	-	-	-	273	273	-	157	157	-
Stage 2	-	-	-	-	-	-	157	158	-	264	277	-
Critical Hdwy	4.12	-	-	4.12	-	-	7.12	6.52	6.22	7.12	6.52	6.22
Critical Hdwy Stg 1	-	-	-	-	-	-	6.12	5.52	-	6.12	5.52	-
Critical Hdwy Stg 2	-	-	-	-	-	-	6.12	5.52	-	6.12	5.52	-
Follow-up Hdwy	2,218	-	-	2,218	-	-	3,518	4,018	3,318	3,518	4,018	3,318
Pot Cap-1 Maneuver	1424	-	-	1344	-	-	535	517	812	543	515	887
Stage 1	-	-	-	-	-	-	733	684	-	845	768	-
Stage 2	-	-	-	-	-	-	845	767	-	741	681	-
Platoon blocked, %	-	-	-	-	-	-	-	-	-	-	-	-
Mov Cap-1 Maneuver	1399	-	-	1324	-	-	493	489	796	516	487	869
Mov Cap-2 Maneuver	-	-	-	-	-	-	493	489	-	516	487	-
Stage 1	-	-	-	-	-	-	707	659	-	813	753	-
Stage 2	-	-	-	-	-	-	802	752	-	714	656	-
Approach	EB			WB			NB			SB		
HCM Control Delay, s	0.8			0.1			11			9.9		
HCM LOS							B			A		
Minor Lane/Major Mvmt	NBLn1	EBL	EBT	EBR	WBL	WBT	WBR	SBLn1				
Capacity (veh/h)	619	1399	-	-	1324	-	-	784				
HCM Lane V/C Ratio	0.027	0.018	-	-	0.001	-	-	0.062				
HCM Control Delay (s)	11	7.6	0	-	7.7	0	-	9.9				
HCM Lane LOS	B	A	A	-	A	A	-	A				
HCM 95th %tile Q(veh)	0.1	0.1	-	-	0	-	-	0.2				

HCM 2010 AWSC
3: Prestone & Centrum

PM Peak Hour
Existing

Intersection						
Intersection Delay, s/veh	8.1					
Intersection LOS	A					
Movement						
	EBT	EBR	WBL	WBT	NBL	NBR
Lane Configurations	↔			↔	↔	↔
Traffic Vol, veh/h	39	108	53	18	72	37
Future Vol, veh/h	39	108	53	18	72	37
Peak Hour Factor	0.90	0.90	0.90	0.90	0.90	0.90
Heavy Vehicles, %	2	6	2	2	11	2
Mvmt Flow	43	120	59	20	80	41
Number of Lanes	1	0	0	1	1	1
Approach						
	EB	WB		NB		
Opposing Approach	WB	EB				
Opposing Lanes	1	1		0		
Conflicting Approach Left		NB		EB		
Conflicting Lanes Left	0	2		1		
Conflicting Approach Right	NB			WB		
Conflicting Lanes Right	2	0		1		
HCM Control Delay	7.8	8.1		8.6		
HCM LOS	A	A		A		
Lane						
	NBLn1	NBLn2	EBLn1	WBLn1		
Vol Left, %	100%	0%	0%	75%		
Vol Thru, %	0%	0%	27%	25%		
Vol Right, %	0%	100%	73%	0%		
Sign Control	Stop	Stop	Stop	Stop		
Traffic Vol by Lane	72	37	147	71		
LT Vol	72	0	0	53		
Through Vol	0	0	39	18		
RT Vol	0	37	108	0		
Lane Flow Rate	80	41	163	79		
Geometry Grp	7	7	2	2		
Degree of Util (X)	0.127	0.05	0.177	0.1		
Departure Headway (Hd)	5.705	4.363	3.905	4.565		
Convergence, Y/N	Yes	Yes	Yes	Yes		
Cap	630	826	921	788		
Service Time	3.422	2.063	1.915	2.577		
HCM Lane V/C Ratio	0.127	0.05	0.177	0.1		
HCM Control Delay	9.3	7.3	7.8	8.1		
HCM Lane LOS	A	A	A	A		
HCM 95th-tile Q	0.4	0.2	0.6	0.3		

HCM 2010 TWSC
4: Centrum & Brisebois E

PM Peak Hour
Existing

Intersection						
Int Delay, s/veh	1.7					
Movement						
	EBL	EBT	WBT	WBR	SBL	SBR
Lane Configurations		↔	↔		↔	↔
Traffic Vol, veh/h	8	48	39	0	0	16
Future Vol, veh/h	8	48	39	0	0	16
Conflicting Peds, #/hr	0	0	0	0	0	0
Sign Control	Free	Free	Free	Free	Stop	Stop
RT Channelized	-	None	-	None	-	None
Storage Length	-	-	-	-	0	-
Veh in Median Storage, #	-	0	0	-	0	-
Grade, %	-	0	0	-	0	-
Peak Hour Factor	90	90	90	90	90	90
Heavy Vehicles, %	2	2	2	2	2	2
Mvmt Flow	9	53	43	0	0	18
Major/Minor						
	Major1	Major2		Minor2		
Conflicting Flow All	43	0	-	0	114	43
Stage 1	-	-	-	-	43	-
Stage 2	-	-	-	-	71	-
Critical Hdwy	4.12	-	-	-	6.42	6.22
Critical Hdwy Stg 1	-	-	-	-	5.42	-
Critical Hdwy Stg 2	-	-	-	-	5.42	-
Follow-up Hdwy	2,218	-	-	-	3,518	3,318
Pot Cap-1 Maneuver	1566	-	-	-	882	1027
Stage 1	-	-	-	-	979	-
Stage 2	-	-	-	-	952	-
Platoon blocked, %	-	-	-	-	-	-
Mov Cap-1 Maneuver	1566	-	-	-	877	1027
Mov Cap-2 Maneuver	-	-	-	-	877	-
Stage 1	-	-	-	-	973	-
Stage 2	-	-	-	-	952	-
Approach						
	EB	WB		SB		
HCM Control Delay, s	1	0		8.6		
HCM LOS				A		
Minor Lane/Major Mvmt						
	EBL	EBT	WBT	WBR	SBLn1	
Capacity (veh/h)	1566	-	-	-	-	1027
HCM Lane V/C Ratio	0.006	-	-	-	-	0.017
HCM Control Delay (s)	7.3	0	-	-	-	8.6
HCM Lane LOS	A	A	-	-	-	A
HCM 95th %tile Q(veh)	0	-	-	-	-	0.1

Lanes, Volumes, Timings
5: Prestone & St Joseph

PM Peak Hour
Existing

Lane Group	EBL	EBT	EBR	WBL	WBT	WBR	NBL	NBT	NBR	SBL	SBT	SBR
Lane Configurations	↔	↕	↕	↕	↕	↕	↕	↕	↕	↕	↕	↕
Traffic Volume (vph)	26	755	116	10	447	106	57	28	9	130	75	26
Future Volume (vph)	26	755	116	10	447	106	57	28	9	130	75	26
Satd. Flow (prot)	1658	3316	1483	1658	3316	1483	1658	1570	0	1658	1567	0
Fit Permitted	0.470			0.317			0.685			0.730		
Satd. Flow (perm)	820	3316	1444	552	3316	1464	1189	1570	0	1273	1567	0
Satd. Flow (RTOR)			129				118		10			22
Lane Group Flow (vph)	29	839	129	11	497	118	63	41	0	144	112	0
Turn Type	Perm	NA	Perm	Perm	NA	Perm	Perm	NA	Perm	NA	NA	
Protected Phases		2			6		8			4		
Permitted Phases	2		2	6		6	8			4		
Detector Phase	2	2	2	6	6	6	8	8		4	4	
Switch Phase												
Minimum Initial (s)	10.0	10.0	10.0	10.0	10.0	10.0	10.0	10.0		10.0	10.0	
Minimum Split (s)	23.7	23.7	23.7	23.7	23.7	23.7	29.0	29.0		29.0	29.0	
Total Split (s)	51.0	51.0	51.0	51.0	51.0	51.0	29.0	29.0		29.0	29.0	
Total Split (%)	63.8%	63.8%	63.8%	63.8%	63.8%	63.8%	36.3%	36.3%		36.3%	36.3%	
Yellow Time (s)	3.3	3.3	3.3	3.3	3.3	3.3	3.3	3.3		3.3	3.3	
All-Red Time (s)	2.4	2.4	2.4	2.4	2.4	2.4	2.7	2.7		2.7	2.7	
Lost Time Adjust (s)	0.0	0.0	0.0	0.0	0.0	0.0	0.0	0.0		0.0	0.0	
Total Lost Time (s)	5.7	5.7	5.7	5.7	5.7	5.7	6.0	6.0		6.0	6.0	
Lead/Lag												
Lead-Lag Optimize?												
Recall Mode	Max	Max	Max	Max	Max	Max	None	None		None	None	
Act Effct Green (s)	48.3	48.3	48.3	48.3	48.3	48.3	14.4	14.4		14.4	14.4	
Actuated g/C Ratio	0.65	0.65	0.65	0.65	0.65	0.65	0.19	0.19		0.19	0.19	
v/c Ratio	0.05	0.39	0.13	0.03	0.23	0.12	0.28	0.13		0.59	0.35	
Control Delay	6.7	7.5	1.9	6.9	6.4	1.9	26.7	19.2		36.1	22.2	
Queue Delay	0.0	0.0	0.0	0.0	0.0	0.0	0.0	0.0		0.0	0.0	
Total Delay	6.7	7.5	1.9	6.9	6.4	1.9	26.7	19.2		36.1	22.2	
LOS	A	A	A	A	A	A	C	B		D	C	
Approach Delay		6.8			5.6			23.7			30.0	
Approach LOS		A			A			C			C	
Queue Length 50th (m)	1.2	23.3	0.0	0.5	12.1	0.0	7.2	3.4		17.5	10.3	
Queue Length 95th (m)	5.3	48.6	6.5	2.8	26.7	6.2	16.5	10.4		33.2	22.5	
Internal Link Dist (m)		163.5			149.6			92.4			92.1	
Turn Bay Length (m)	50.0		105.0	62.5		120.0	47.5					
Base Capacity (vph)	531	2150	981	357	2150	990	369	494		395	502	
Starvation Cap Reductn	0	0	0	0	0	0	0	0		0	0	
Spillback Cap Reductn	0	0	0	0	0	0	0	0		0	0	
Storage Cap Reductn	0	0	0	0	0	0	0	0		0	0	
Reduced v/c Ratio	0.05	0.39	0.13	0.03	0.23	0.12	0.17	0.08		0.36	0.22	

Intersection Summary

Cycle Length: 80
Actuated Cycle Length: 74.4
Natural Cycle: 55
Control Type: Actuated-Uncoordinated
Maximum v/c Ratio: 0.59

Lanes, Volumes, Timings
5: Prestone & St Joseph

PM Peak Hour
Existing

Intersection Signal Delay: 10.3
Intersection Capacity Utilization 48.1%
Analysis Period (min) 15
Intersection LOS: B
ICU Level of Service A

Splits and Phases: 5: Prestone & St Joseph



Appendix D

Collision Data

Accident Date	Accident Year	Accident Time	Location	Environment Condition	Light	Traffic Control	Traffic Control Condition	Classification Of Accident	Initial Impact Type	Road Surface Condition	# Vehicles	# Motorcycles	# Bicycles	# Pedestrians
1/13/2016	2016	14:50	CENTRUM BLVD @ PRESTONE DR (0012922)	03 - Snow	01 - Daylight	02 - Stop sign	01 - Functioning	02 - Non-fatal injury	07 - SMV other	03 - Loose snow	1	0	0	1
2/2/2019	2019	10:11	CENTRUM BLVD @ PRESTONE DR (0012922)	03 - Snow	01 - Daylight	02 - Stop sign	01 - Functioning	03 - P.D. only	03 - Rear end	05 - Packed snow	2	0	0	0
3/10/2016	2016	15:18	CENTRUM BLVD btwn PLACE D'ORLEANS DR & PRESTONE DR (_32AS2B)	01 - Clear	01 - Daylight	10 - No control	0	03 - P.D. only	04 - Sideswipe	01 - Dry	2	0	0	0
10/10/2018	2018	12:22	CENTRUM BLVD btwn PLACE D'ORLEANS DR & PRESTONE DR (_32AS2B)	01 - Clear	01 - Daylight	10 - No control	0	02 - Non-fatal injury	07 - SMV other	01 - Dry	1	0	0	0
11/12/2019	2019	10:30	CENTRUM BLVD btwn PLACE D'ORLEANS DR & PRESTONE DR (_32AS2B)	03 - Snow	01 - Daylight	10 - No control	0	03 - P.D. only	02 - Angle	03 - Loose snow	2	0	0	0
12/4/2019	2019	11:46	CENTRUM BLVD btwn PLACE D'ORLEANS DR & PRESTONE DR (_32AS2B)	04 - Freezing Rain	01 - Daylight	10 - No control	0	03 - P.D. only	02 - Angle	03 - Loose snow	2	0	0	0
2/5/2020	2020	9:35	CENTRUM BLVD btwn PLACE D'ORLEANS DR & PRESTONE DR (_32AS2B)	01 - Clear	01 - Daylight	10 - No control	0	03 - P.D. only	01 - Approaching	01 - Dry	2	0	0	0
4/6/2016	2016	18:25	PLACE D'ORLEANS @ CENTRUM BLVD/PLACE D'ORLEANS (0004167)	03 - Snow	01 - Daylight	01 - Traffic signal	01 - Functioning	03 - P.D. only	03 - Rear end	03 - Loose snow	2	0	0	0
5/31/2016	2016	11:42	PLACE D'ORLEANS @ CENTRUM BLVD/PLACE D'ORLEANS (0004167)	01 - Clear	01 - Daylight	01 - Traffic signal	01 - Functioning	03 - P.D. only	07 - SMV other	01 - Dry	1	0	0	1
9/28/2018	2018	11:54	PLACE D'ORLEANS @ CENTRUM BLVD/PLACE D'ORLEANS (0004167)	01 - Clear	01 - Daylight	01 - Traffic signal	01 - Functioning	03 - P.D. only	02 - Angle	01 - Dry	2	0	0	0
3/27/2018	2018	12:30	PLACE D'ORLEANS @ CENTRUM BLVD/PLACE D'ORLEANS (0004167)	01 - Clear	01 - Daylight	01 - Traffic signal	01 - Functioning	03 - P.D. only	05 - Turning movement	01 - Dry	2	0	0	0
1/15/2018	2018	11:58	PLACE D'ORLEANS @ CENTRUM BLVD/PLACE D'ORLEANS (0004167)	01 - Clear	01 - Daylight	01 - Traffic signal	01 - Functioning	03 - P.D. only	02 - Angle	05 - Packed snow	2	0	0	0
1/13/2019	2019	13:44	PLACE D'ORLEANS @ CENTRUM BLVD/PLACE D'ORLEANS (0004167)	01 - Clear	01 - Daylight	01 - Traffic signal	01 - Functioning	03 - P.D. only	02 - Angle	01 - Dry	2	0	0	0
8/29/2016	2016	12:11	PLACE D'ORLEANS DR btwn TURN LANE & CENTRUM BLVD (_3ZBP94)	01 - Clear	01 - Daylight	10 - No control	0	03 - P.D. only	04 - Sideswipe	01 - Dry	2	0	0	0
8/30/2016	2016	21:55	PLACE D'ORLEANS DR btwn CENTRUM BLVD & ST. JOSEPH BLVD (_3ZA2FM)	01 - Clear	07 - Dark	10 - No control	0	02 - Non-fatal injury	05 - Turning movement	01 - Dry	2	0	0	0
1/28/2017	2017	18:36	PLACE D'ORLEANS DR btwn CENTRUM BLVD & ST. JOSEPH BLVD (_3ZA2FM)	01 - Clear	07 - Dark	10 - No control	0	03 - P.D. only	05 - Turning movement	02 - Wet	2	0	0	0
11/1/2018	2018	7:11	PLACE D'ORLEANS DR btwn CENTRUM BLVD & ST. JOSEPH BLVD (_3ZA2FM)	07 - Fog, mist, smoke, dust	03 - Dawn	10 - No control	0	02 - Non-fatal injury	07 - SMV other	01 - Dry	1	0	0	0
3/25/2018	2018	23:11	PLACE D'ORLEANS DR btwn CENTRUM BLVD & ST. JOSEPH BLVD (_3ZA2FM)	01 - Clear	07 - Dark	10 - No control	0	03 - P.D. only	02 - Angle	01 - Dry	2	0	0	0
5/29/2018	2018	14:39	PLACE D'ORLEANS DR btwn CENTRUM BLVD & ST. JOSEPH BLVD (_3ZA2FM)	01 - Clear	01 - Daylight	10 - No control	0	03 - P.D. only	02 - Angle	01 - Dry	2	0	0	0
10/23/2019	2019	16:36	PLACE D'ORLEANS DR btwn CENTRUM BLVD & ST. JOSEPH BLVD (_3ZA2FM)	01 - Clear	01 - Daylight	10 - No control	0	03 - P.D. only	02 - Angle	01 - Dry	2	0	0	0
4/22/2020	2020	10:10	PLACE D'ORLEANS DR btwn CENTRUM BLVD & ST. JOSEPH BLVD (_3ZA2FM)	01 - Clear	01 - Daylight	10 - No control	0	03 - P.D. only	02 - Angle	01 - Dry	2	0	0	0
3/13/2016	2016	14:12	PRESTONE DR @ ST. JOSEPH BLVD (0003551)	01 - Clear	01 - Daylight	01 - Traffic signal	01 - Functioning	03 - P.D. only	02 - Angle	02 - Wet	2	0	0	0
4/23/2017	2017	13:57	PRESTONE DR @ ST. JOSEPH BLVD (0003551)	01 - Clear	01 - Daylight	01 - Traffic signal	01 - Functioning	02 - Non-fatal injury	02 - Angle	01 - Dry	2	0	0	0
6/24/2017	2017	11:00	PRESTONE DR @ ST. JOSEPH BLVD (0003551)	01 - Clear	01 - Daylight	01 - Traffic signal	01 - Functioning	02 - Non-fatal injury	05 - Turning movement	01 - Dry	2	0	0	0
10/25/2018	2018	19:15	PRESTONE DR @ ST. JOSEPH BLVD (0003551)	01 - Clear	07 - Dark	01 - Traffic signal	01 - Functioning	03 - P.D. only	03 - Rear end	01 - Dry	2	0	0	0
7/31/2018	2018	7:50	PRESTONE DR @ ST. JOSEPH BLVD (0003551)	01 - Clear	01 - Daylight	01 - Traffic signal	01 - Functioning	03 - P.D. only	03 - Rear end	01 - Dry	2	0	0	0
8/21/2018	2018	16:00	PRESTONE DR @ ST. JOSEPH BLVD (0003551)	02 - Rain	01 - Daylight	01 - Traffic signal	01 - Functioning	03 - P.D. only	05 - Turning movement	02 - Wet	2	0	0	0
8/28/2018	2018	16:56	PRESTONE DR @ ST. JOSEPH BLVD (0003551)	01 - Clear	01 - Daylight	01 - Traffic signal	01 - Functioning	03 - P.D. only	05 - Turning movement	01 - Dry	2	0	0	0
1/23/2019	2019	12:18	PRESTONE DR @ ST. JOSEPH BLVD (0003551)	03 - Snow	01 - Daylight	01 - Traffic signal	01 - Functioning	02 - Non-fatal injury	02 - Angle	03 - Loose snow	2	0	0	0
1/27/2019	2019	5:30	PRESTONE DR @ ST. JOSEPH BLVD (0003551)	03 - Snow	07 - Dark	01 - Traffic signal	01 - Functioning	03 - P.D. only	07 - SMV other	03 - Loose snow	1	0	0	0
2/19/2019	2019	10:34	PRESTONE DR @ ST. JOSEPH BLVD (0003551)	01 - Clear	01 - Daylight	01 - Traffic signal	01 - Functioning	03 - P.D. only	02 - Angle	01 - Dry	2	0	0	0
1/17/2020	2020	9:13	PRESTONE DR @ ST. JOSEPH BLVD (0003551)	01 - Clear	01 - Daylight	01 - Traffic signal	01 - Functioning	02 - Non-fatal injury	07 - SMV other	01 - Dry	1	0	0	1

Appendix E

TRANS Plot

TRANS Regional Model

Version 2.15 - Assigned June 16, 2020

AM Peak Hour Total Traffic Volume

265 Centrum Boulevard

2011 Model - Basecase

N/A

User Initials: TIMW

Plot Prepared: January, 2023

EMME Scenario: 21713



Legend

AM Peak Hour Total Traffic Volume

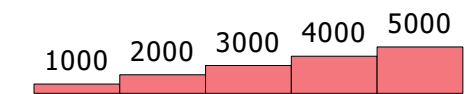

Distance (m)

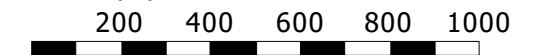

The TRANS model is continuously refined & maintained, and all information is provided in good faith. However, model outputs are provided "as is", and no warranty or guarantee is provided as to the accuracy, reliability or reasonableness of the results. In using this data, you agree to accept any and all risks arising from any incorrect, incomplete, or misleading information.

Recipients are required to use caution and professional judgement in using and interpreting model outputs. In particular, caution should be used when focusing on a geographically limited area (such as a single road or intersection), as the model is primarily designed to simulate regional-scale phenomena and has been calibrated at a regional level.

As general good practice, it is recommended that the user confirm the network coding within the area of interest, and compare base year forecasts against traffic count data to assess the extent to which the model may be over- or under-estimating the travel demand.

TRANS Regional Model

Version 2.15 - Assigned June 16, 2020

AM Peak Hour Total Traffic Volume

265 Centrum Boulevard

2031 Model - Basecase

N/A

User Initials: TIMW

Plot Prepared: January, 2023

EMME Scenario: 21715



Legend

AM Peak Hour Total Traffic Volume

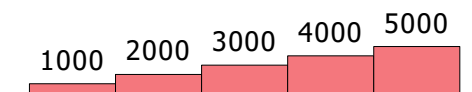

Distance (m)

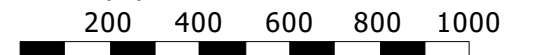

The TRANS model is continuously refined & maintained, and all information is provided in good faith. However, model outputs are provided "as is", and no warranty or guarantee is provided as to the accuracy, reliability or reasonableness of the results. In using this data, you agree to accept any and all risks arising from any incorrect, incomplete, or misleading information.

Recipients are required to use caution and professional judgement in using and interpreting model outputs. In particular, caution should be used when focusing on a geographically limited area (such as a single road or intersection), as the model is primarily designed to simulate regional-scale phenomena and has been calibrated at a regional level.

As a general good practice, it is recommended that the user confirm the network coding within the area of interest, and compare base year forecasts against traffic count data to assess the extent to which the model may be over- or under-estimating the travel demand.

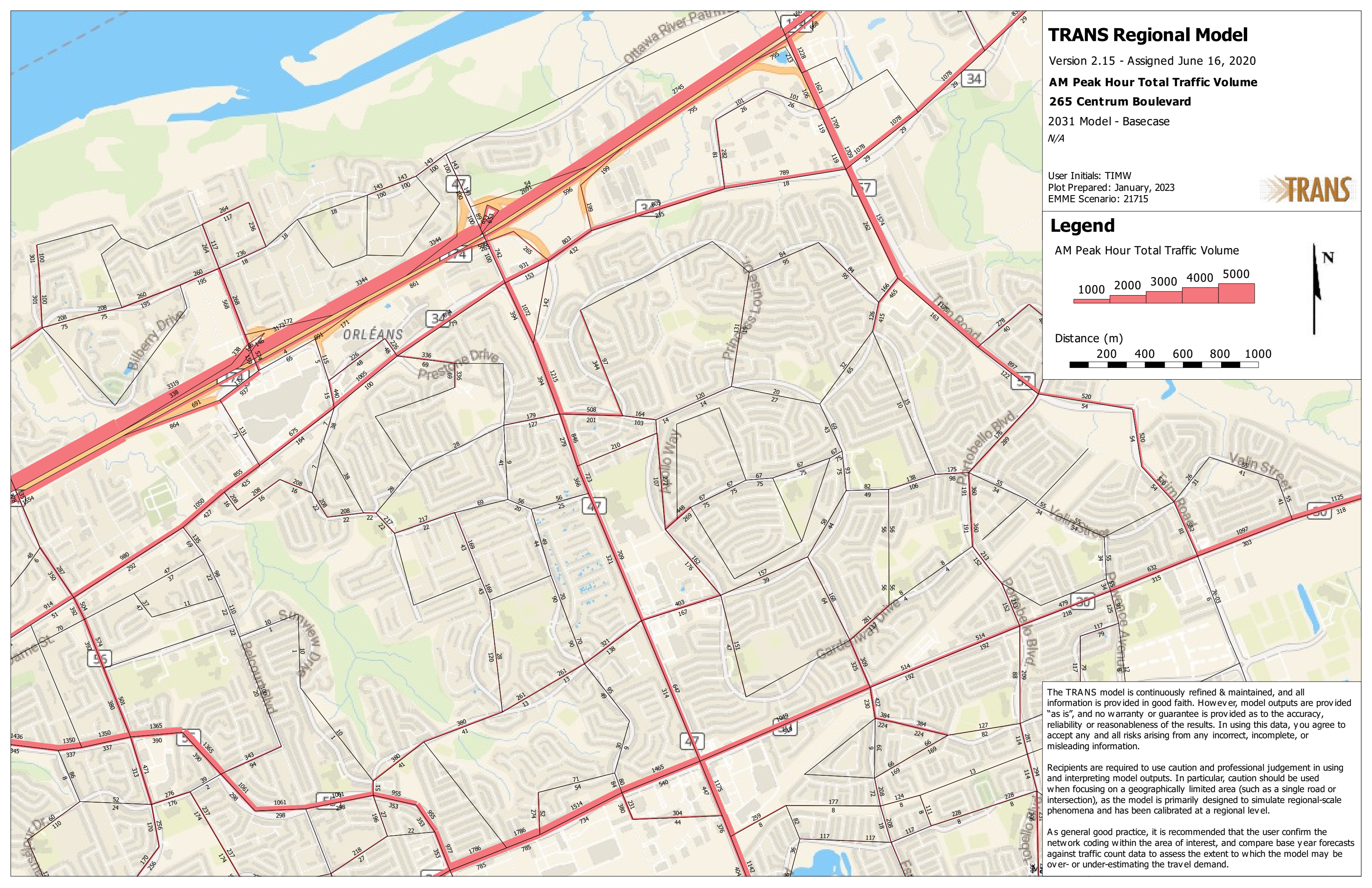

Appendix F

Background Volumes

Figure 5: Assignment of Site Trips

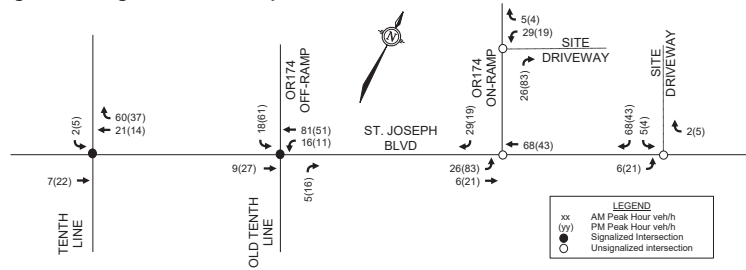
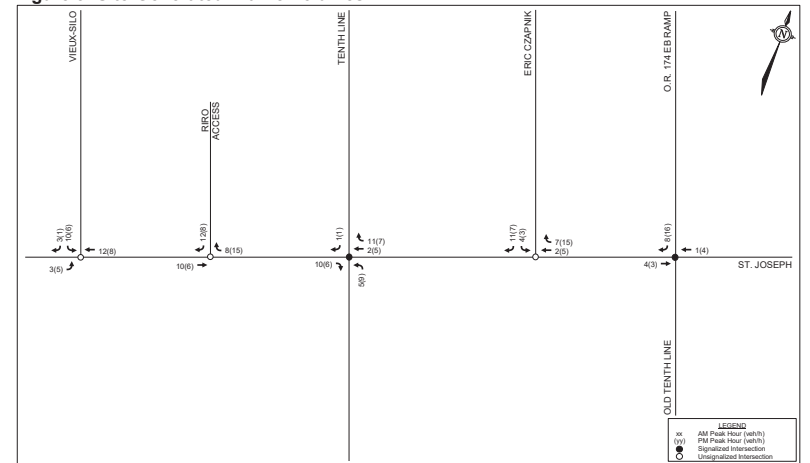

Figure 5: Site-Generated Traffic Volumes



Appendix G

Synchro Intersection Worksheets – 2028 Future Background Conditions

Lanes, Volumes, Timings
1: Place d'Orleans & Centrum

AM Peak Hour
2028 Future Background

Lane Group	EBL	EBT	EBR	WBL	WBT	WBR	NBL	NBT	NBR	SBL	SBT	SBR
Lane Configurations	↔	↔	↔	↔	↔	↔	↔	↔	↔	↔	↔	↔
Traffic Volume (vph)	25	30	40	22	32	1	67	159	52	110	42	19
Future Volume (vph)	25	30	40	22	32	1	67	159	52	110	42	19
Satd. Flow (prot)	1566	1745	1401	1658	1719	0	0	3149	0	0	3025	0
Fit Permitted	0.736			0.738				0.853			0.695	
Satd. Flow (perm)	1205	1745	1375	1280	1719	0	0	2718	0	0	2170	0
Satd. Flow (RTOR)			44		1			52			19	
Lane Group Flow (vph)	25	30	40	22	33	0	0	278	0	0	171	0
Turn Type	Perm	NA	Perm	Perm	NA		Perm	NA		Perm	NA	
Protected Phases	4			8			2			6		
Permitted Phases	4		4	8			2			6		
Detector Phase	4	4	4	8	8		2	2		6	6	
Switch Phase												
Minimum Initial (s)	10.0	10.0	10.0	10.0	10.0		10.0	10.0		10.0	10.0	
Minimum Split (s)	31.0	31.0	31.0	31.0	31.0		36.0	36.0		36.0	36.0	
Total Split (s)	32.0	32.0	32.0	32.0	32.0		43.0	43.0		43.0	43.0	
Total Split (%)	42.7%	42.7%	42.7%	42.7%	42.7%		57.3%	57.3%		57.3%	57.3%	
Yellow Time (s)	3.3	3.3	3.3	3.3	3.3		3.3	3.3		3.3	3.3	
All-Red Time (s)	2.7	2.7	2.7	2.7	2.7		2.7	2.7		2.7	2.7	
Lost Time Adjust (s)	0.0	0.0	0.0	0.0	0.0		0.0	0.0		0.0	0.0	
Total Lost Time (s)	6.0	6.0	6.0	6.0	6.0		6.0	6.0		6.0	6.0	
Lead/Lag												
Lead-Lag Optimize?												
Recall Mode	None	None	None	None	None		Max	Max		Max	Max	
Act Effct Green (s)	12.6	12.6	12.6	12.6	12.6		46.3	46.3		46.3	46.3	
Actuated g/C Ratio	0.20	0.20	0.20	0.20	0.20		0.75	0.75		0.75	0.75	
v/c Ratio	0.10	0.08	0.13	0.08	0.09		0.14	0.10		0.10	0.10	
Control Delay	20.0	19.5	7.0	19.6	19.2		4.8	5.4		4.8	5.4	
Queue Delay	0.0	0.0	0.0	0.0	0.0		0.0	0.0		0.0	0.0	
Total Delay	20.0	19.5	7.0	19.6	19.2		4.8	5.4		4.8	5.4	
LOS	B	B	A	B	B		A	A		A	A	
Approach Delay		14.4			19.3		4.8	5.4		4.8	5.4	
Approach LOS		B			B		A	A		A	A	
Queue Length 50th (m)	2.3	2.8	0.0	2.0	3.0		4.3	2.8		4.3	2.8	
Queue Length 95th (m)	7.2	8.0	5.5	6.5	8.4		14.7	10.6		14.7	10.6	
Internal Link Dist (m)		55.7			119.8		103.0	90.8		103.0	90.8	
Turn Bay Length (m)	52.0		20.0									
Base Capacity (vph)	513	743	610	545	732		2053	1634		2053	1634	
Starvation Cap Reductn	0	0	0	0	0		0	0		0	0	
Spillback Cap Reductn	0	0	0	0	0		0	0		0	0	
Storage Cap Reductn	0	0	0	0	0		0	0		0	0	
Reduced v/c Ratio	0.05	0.04	0.07	0.04	0.05		0.14	0.10		0.14	0.10	

Intersection Summary	
Cycle Length:	75
Actuated Cycle Length:	61.6
Natural Cycle:	70
Control Type:	Actuated-Uncoordinated
Maximum v/c Ratio:	0.14

Lanes, Volumes, Timings
1: Place d'Orleans & Centrum

AM Peak Hour
2028 Future Background

Intersection Signal Delay: 7.8	Intersection LOS: A
Intersection Capacity Utilization 59.7%	ICU Level of Service B
Analysis Period (min) 15	

Splits and Phases: 1: Place d'Orleans & Centrum



HCM 2010 TWSC
2: Centrum & Brisebois W

AM Peak Hour
2028 Future Background

Intersection												
Int Delay, s/veh	1.3											
Movement	EBL	EBT	EBR	WBL	WBT	WBR	NBL	NBT	NBR	SBL	SBT	SBR
Lane Configurations	↔			↔			↔			↔		
Traffic Vol, veh/h	24	81	10	2	126	3	0	0	1	1	0	13
Future Vol, veh/h	24	81	10	2	126	3	0	0	1	1	0	13
Conflicting Peds, #/hr	8	0	9	9	0	8	0	0	3	3	0	0
Sign Control	Free	Free	Free	Free	Free	Free	Stop	Stop	Stop	Stop	Stop	Stop
RT Channelized	-	-	None	-	-	None	-	-	None	-	-	None
Storage Length	-	-	-	-	-	-	-	-	-	-	-	-
Veh in Median Storage, #	-	0	-	-	0	-	-	0	-	-	0	-
Grade, %	-	0	-	-	0	-	-	0	-	-	0	-
Peak Hour Factor	100	100	100	100	100	100	100	100	100	100	100	100
Heavy Vehicles, %	2	5	2	2	3	2	2	2	100	2	2	2
Mvmt Flow	24	81	10	2	126	3	0	0	1	1	0	13
Major/Minor	Major1	Major2			Minor1			Minor2				
Conflicting Flow All	137	0	0	100	0	0	281	284	98	278	288	136
Stage 1	-	-	-	-	-	-	143	143	-	140	140	-
Stage 2	-	-	-	-	-	-	138	141	-	138	148	-
Critical Hdwy	4.12	-	-	4.12	-	-	7.12	6.52	7.2	7.12	6.52	6.22
Critical Hdwy Stg 1	-	-	-	-	-	-	6.12	5.52	-	6.12	5.52	-
Critical Hdwy Stg 2	-	-	-	-	-	-	6.12	5.52	-	6.12	5.52	-
Follow-up Hdwy	2.218	-	-	2.218	-	-	3.518	4.018	4.2	3.518	4.018	3.318
Pot Cap-1 Maneuver	1447	-	-	1493	-	-	671	625	746	674	622	913
Stage 1	-	-	-	-	-	-	860	779	-	863	781	-
Stage 2	-	-	-	-	-	-	865	780	-	865	775	-
Platoon blocked, %	-	-	-	-	-	-	-	-	-	-	-	-
Mov Cap-1 Maneuver	1438	-	-	1483	-	-	648	605	739	658	602	907
Mov Cap-2 Maneuver	-	-	-	-	-	-	648	605	-	658	602	-
Stage 1	-	-	-	-	-	-	839	760	-	842	776	-
Stage 2	-	-	-	-	-	-	852	775	-	846	756	-
Approach	EB	WB			NB			SB				
HCM Control Delay, s	1.6	0.1			9.9			9.1				
HCM LOS	A			A			A					
Minor Lane/Major Mvmt	NBLn1	EBL	EBT	EBR	WBL	WBT	WBR	SBLn1				
Capacity (veh/h)	739	1438	-	-	1483	-	-	883				
HCM Lane V/C Ratio	0.001	0.017	-	-	0.001	-	-	0.016				
HCM Control Delay (s)	9.9	7.5	0	-	7.4	0	-	9.1				
HCM Lane LOS	A	A	A	-	A	A	-	A				
HCM 95th %tile Q(veh)	0	0.1	-	-	0	-	-	0				

HCM 2010 AWSC
3: Prestone & Centrum

AM Peak Hour
2028 Future Background

Intersection						
Intersection Delay, s/veh	7.6					
Intersection LOS	A					
Movement	EBT	EBR	WBL	WBT	NBL	NBR
Lane Configurations	↔			↔	↔	↔
Traffic Vol, veh/h	20	41	39	18	55	36
Future Vol, veh/h	20	41	39	18	55	36
Peak Hour Factor	1.00	1.00	1.00	1.00	1.00	1.00
Heavy Vehicles, %	5	17	2	6	7	2
Mvmt Flow	20	41	39	18	55	36
Number of Lanes	1	0	0	1	1	1
Approach	EB	WB		NB		
Opposing Approach	WB	EB				
Opposing Lanes	1	1		0		
Conflicting Approach Left		NB		EB		
Conflicting Lanes Left	0	2		1		
Conflicting Approach Right	NB			WB		
Conflicting Lanes Right	2	0		1		
HCM Control Delay	7.1	7.7		7.9		
HCM LOS	A	A		A		
Lane	NBLn1	NBLn2	EBLn1	WBLn1		
Vol Left, %	100%	0%	0%	68%		
Vol Thru, %	0%	0%	33%	32%		
Vol Right, %	0%	100%	67%	0%		
Sign Control	Stop	Stop	Stop	Stop		
Traffic Vol by Lane	55	36	61	57		
LT Vol	55	0	0	39		
Through Vol	0	0	20	18		
RT Vol	0	36	41	0		
Lane Flow Rate	55	36	61	57		
Geometry Grp	7	7	2	2		
Degree of Util (X)	0.081	0.04	0.064	0.068		
Departure Headway (Hd)	5.324	4.037	3.78	4.273		
Convergence, Y/N	Yes	Yes	Yes	Yes		
Cap	670	881	931	827		
Service Time	3.076	1.789	1.871	2.357		
HCM Lane V/C Ratio	0.082	0.041	0.066	0.069		
HCM Control Delay	8.5	7	7.1	7.7		
HCM Lane LOS	A	A	A	A		
HCM 95th-tile Q	0.3	0.1	0.2	0.2		

HCM 2010 TWSC
4: Centrum & Brisebois E

AM Peak Hour
2028 Future Background

Intersection						
Int Delay, s/veh	2					
Movement	EBL	EBT	WBT	WBR	SBL	SBR
Lane Configurations		↕	↕		↕	↕
Traffic Vol, veh/h	11	19	26	1	0	5
Future Vol, veh/h	11	19	26	1	0	5
Conflicting Peds, #/hr	0	0	0	0	0	0
Sign Control	Free	Free	Free	Free	Stop	Stop
RT Channelized	-	None	-	None	-	None
Storage Length	-	-	-	-	0	-
Veh in Median Storage, #	-	0	0	-	0	-
Grade, %	-	0	0	-	0	-
Peak Hour Factor	100	100	100	100	100	100
Heavy Vehicles, %	9	2	2	2	2	20
Mvmt Flow	11	19	26	1	0	5
Major/Minor	Major1	Major2	Minor2			
Conflicting Flow All	27	0	0	68	27	
Stage 1	-	-	-	27	-	
Stage 2	-	-	-	41	-	
Critical Hdwy	4.19	-	-	6.42	6.4	
Critical Hdwy Stg 1	-	-	-	5.42	-	
Critical Hdwy Stg 2	-	-	-	5.42	-	
Follow-up Hdwy	2.281	-	-	3.518	3.48	
Pot Cap-1 Maneuver	1543	-	-	937	999	
Stage 1	-	-	-	996	-	
Stage 2	-	-	-	981	-	
Platoon blocked, %	-	-	-	-	-	
Mov Cap-1 Maneuver	1543	-	-	930	999	
Mov Cap-2 Maneuver	-	-	-	930	-	
Stage 1	-	-	-	989	-	
Stage 2	-	-	-	981	-	
Approach	EB	WB	SB			
HCM Control Delay, s	2.7	0	8.6			
HCM LOS			A			
Minor Lane/Major Mvmt	EBL	EBT	WBT	WBR	SBLn1	
Capacity (veh/h)	1543	-	-	-	999	
HCM Lane V/C Ratio	0.007	-	-	-	0.005	
HCM Control Delay (s)	7.3	0	-	-	8.6	
HCM Lane LOS	A	A	-	-	A	
HCM 95th %tile Q(veh)	0	-	-	-	0	

Lanes, Volumes, Timings
5: Prestone & St Joseph

AM Peak Hour
2028 Future Background



Lane Group	EBL	EBT	EBR	WBL	WBT	WBR	NBL	NBT	NBR	SBL	SBT	SBR
Lane Configurations	↕	↕↕	↕	↕	↕↕	↕	↕	↕	↕	↕	↕	↕
Traffic Volume (vph)	7	177	40	2	771	103	81	46	5	40	26	12
Future Volume (vph)	7	177	40	2	771	103	81	46	5	40	26	12
Satd. Flow (prot)	1658	3316	1375	1658	3316	1441	1626	1687	0	1566	1314	0
Fit Permitted	0.272			0.640			0.732			0.724		
Satd. Flow (perm)	475	3316	1375	1117	3316	1423	1252	1687	0	1191	1314	0
Satd. Flow (RTOR)			41			103		5			12	
Lane Group Flow (vph)	7	177	40	2	771	103	81	51	0	40	38	0
Turn Type	Perm	NA	Perm	Perm	NA	Perm	Perm	NA		Perm	NA	
Protected Phases		2			6			8			4	
Permitted Phases	2		2	6		6	8				4	
Detector Phase	2	2	2	6	6	6	8	8			4	4
Switch Phase												
Minimum Initial (s)	10.0	10.0	10.0	10.0	10.0	10.0	10.0	10.0		10.0	10.0	
Minimum Split (s)	23.7	23.7	23.7	23.7	23.7	23.7	29.0	29.0		29.0	29.0	
Total Split (s)	51.0	51.0	51.0	51.0	51.0	51.0	29.0	29.0		29.0	29.0	
Total Split (%)	63.8%	63.8%	63.8%	63.8%	63.8%	63.8%	36.3%	36.3%		36.3%	36.3%	
Yellow Time (s)	3.3	3.3	3.3	3.3	3.3	3.3	3.3	3.3		3.3	3.3	
All-Red Time (s)	2.4	2.4	2.4	2.4	2.4	2.4	2.7	2.7		2.7	2.7	
Lost Time Adjust (s)	0.0	0.0	0.0	0.0	0.0	0.0	0.0	0.0		0.0	0.0	
Total Lost Time (s)	5.7	5.7	5.7	5.7	5.7	5.7	6.0	6.0		6.0	6.0	
Lead/Lag												
Lead-Lag Optimize?												
Recall Mode	None	None	None	None	None	None	Max	Max		Max	Max	
Act Effct Green (s)	18.1	18.1	18.1	18.1	18.1	18.1	23.1	23.1		23.1	23.1	
Actuated g/C Ratio	0.34	0.34	0.34	0.34	0.34	0.34	0.44	0.44		0.44	0.44	
v/c Ratio	0.04	0.16	0.08	0.01	0.68	0.19	0.15	0.07		0.08	0.07	
Control Delay	11.6	12.0	4.6	10.5	18.2	3.9	11.5	9.9		10.9	8.6	
Queue Delay	0.0	0.0	0.0	0.0	0.0	0.0	0.0	0.0		0.0	0.0	
Total Delay	11.6	12.0	4.6	10.5	18.2	3.9	11.5	9.9		10.9	8.6	
LOS	B	B	A	B	B	A	B	A		B	A	
Approach Delay	10.7				16.5		10.8					9.8
Approach LOS	B				B		B					A
Queue Length 50th (m)	0.4	6.0	0.0	0.1	32.1	0.0	4.3	2.3		2.1	1.3	
Queue Length 95th (m)	2.4	11.0	4.3	1.1	46.5	7.0	13.1	8.5		7.7	6.4	
Internal Link Dist (m)	163.5				149.6		92.4					92.1
Turn Bay Length (m)	50.0		105.0		62.5		120.0		47.5			
Base Capacity (vph)	408	2850	1187	960	2850	1237	546	739		519	580	
Starvation Cap Reductn	0	0	0	0	0	0	0	0		0	0	
Spillback Cap Reductn	0	0	0	0	0	0	0	0		0	0	
Storage Cap Reductn	0	0	0	0	0	0	0	0		0	0	
Reduced v/c Ratio	0.02	0.06	0.03	0.00	0.27	0.08	0.15	0.07		0.08	0.07	

Intersection Summary	
Cycle Length:	80
Actuated Cycle Length:	53
Natural Cycle:	55
Control Type:	Actuated-Uncoordinated
Maximum v/c Ratio:	0.68

Lanes, Volumes, Timings
5: Prestone & St Joseph

AM Peak Hour
2028 Future Background

Intersection Signal Delay: 14.5 Intersection LOS: B
Intersection Capacity Utilization 51.4% ICU Level of Service A
Analysis Period (min) 15

Splits and Phases: 5: Prestone & St Joseph



Lanes, Volumes, Timings
1: Place d'Orleans & Centrum

PM Peak Hour
2028 Future Background

Lane Group	EBL	EBT	EBR	WBL	WBT	WBR	NBL	NBT	NBR	SBL	SBT	SBR
Lane Configurations	↔	↕	↗	↖	↗	↖	↕	↕	↗	↖	↕	↕
Traffic Volume (vph)	94	57	220	41	46	0	102	153	65	108	144	42
Future Volume (vph)	94	57	220	41	46	0	102	153	65	108	144	42
Satd. Flow (prot)	1658	1745	1483	1658	1745	0	0	3104	0	0	3109	0
Fit Permitted	0.727			0.720				0.762			0.734	
Satd. Flow (perm)	1252	1745	1448	1242	1745	0	0	2401	0	0	2320	0
Satd. Flow (RTOR)			220					60			35	
Lane Group Flow (vph)	94	57	220	41	46	0	0	320	0	0	294	0
Turn Type	Perm	NA	Perm	Perm	NA		Perm	NA		Perm	NA	
Protected Phases		4			8			2			6	
Permitted Phases	4		4	8			2			6		
Detector Phase	4	4	4	8	8		2	2		6	6	
Switch Phase												
Minimum Initial (s)	10.0	10.0	10.0	10.0	10.0		10.0	10.0		10.0	10.0	
Minimum Split (s)	31.0	31.0	31.0	31.0	31.0		36.0	36.0		36.0	36.0	
Total Split (s)	32.0	32.0	32.0	32.0	32.0		53.0	53.0		53.0	53.0	
Total Split (%)	37.6%	37.6%	37.6%	37.6%	37.6%		62.4%	62.4%		62.4%	62.4%	
Yellow Time (s)	3.3	3.3	3.3	3.3	3.3		3.3	3.3		3.3	3.3	
All-Red Time (s)	2.7	2.7	2.7	2.7	2.7		2.7	2.7		2.7	2.7	
Lost Time Adjust (s)	0.0	0.0	0.0	0.0	0.0		0.0	0.0		0.0	0.0	
Total Lost Time (s)	6.0	6.0	6.0	6.0	6.0		6.0	6.0		6.0	6.0	
Lead/Lag												
Lead-Lag Optimize?												
Recall Mode	None	None	None	None	None		C-Max	C-Max		C-Max	C-Max	
Act Effct Green (s)	14.1	14.1	14.1	14.1	14.1		58.9	58.9		58.9	58.9	
Actuated g/C Ratio	0.17	0.17	0.17	0.17	0.17		0.69	0.69		0.69	0.69	
v/c Ratio	0.45	0.20	0.52	0.20	0.16		0.19	0.18		0.18	0.18	
Control Delay	37.3	29.7	8.6	30.2	29.0		4.9	5.2		4.9	5.2	
Queue Delay	0.0	0.0	0.0	0.0	0.0		0.0	0.0		0.0	0.0	
Total Delay	37.3	29.7	8.6	30.2	29.0		4.9	5.2		4.9	5.2	
LOS	D	C	A	C	C		A	A		A	A	
Approach Delay		19.1			29.6		4.9	5.2		4.9	5.2	
Approach LOS		B			C		A	A		A	A	
Queue Length 50th (m)	14.4	8.4	0.0	6.0	6.7		5.7	5.7		5.7	5.7	
Queue Length 95th (m)	23.7	15.2	15.1	12.3	13.0		16.6	16.4		16.6	16.4	
Internal Link Dist (m)		55.7			119.8		103.0	90.8		103.0	90.8	
Turn Bay Length (m)	52.0		20.0									
Base Capacity (vph)	382	533	595	379	533		1681	1617		1681	1617	
Starvation Cap Reductn	0	0	0	0	0		0	0		0	0	
Spillback Cap Reductn	0	0	0	0	0		0	0		0	0	
Storage Cap Reductn	0	0	0	0	0		0	0		0	0	
Reduced v/c Ratio	0.25	0.11	0.37	0.11	0.09		0.19	0.18		0.19	0.18	

Intersection Summary
Cycle Length: 85
Actuated Cycle Length: 85
Offset: 0 (0%), Referenced to phase 2:NBTL and 6:SBTL, Start of Green
Natural Cycle: 70
Control Type: Actuated-Coordinated

Lanes, Volumes, Timings
1: Place d'Orleans & Centrum

PM Peak Hour
2028 Future Background

Maximum v/c Ratio: 0.52	Intersection LOS: B
Intersection Signal Delay: 11.9	ICU Level of Service D
Intersection Capacity Utilization 80.0%	
Analysis Period (min) 15	

Splits and Phases: 1: Place d'Orleans & Centrum

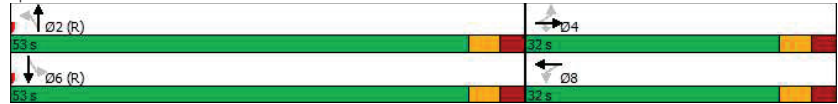

HCM 2010 TWSC
2: Centrum & Brisebois W

PM Peak Hour
2028 Future Background

Intersection												
Int Delay, s/veh 2												
Movement	EBL	EBT	EBR	WBL	WBT	WBR	NBL	NBT	NBR	SBL	SBT	SBR
Lane Configurations	↔			↔			↕			↕		
Traffic Vol, veh/h	23	179	8	1	118	3	7	0	8	7	0	37
Future Vol, veh/h	23	179	8	1	118	3	7	0	8	7	0	37
Conflicting Peds, #/hr	23	0	19	19	0	23	3	0	6	6	0	3
Sign Control	Free	Free	Free	Free	Free	Free	Stop	Stop	Stop	Stop	Stop	Stop
RT Channelized	-	-	None	-	-	None	-	-	None	-	-	None
Storage Length	-	-	-	-	-	-	-	-	-	-	-	-
Veh in Median Storage, #	-	0	-	-	0	-	-	0	-	-	0	-
Grade, %	-	0	-	-	0	-	-	0	-	-	0	-
Peak Hour Factor	100	100	100	100	100	100	100	100	100	100	100	100
Heavy Vehicles, %	2	3	2	2	5	2	2	2	2	2	2	2
Mvmt Flow	23	179	8	1	118	3	7	0	8	7	0	37

Major/Minor	Major1			Major2			Minor1			Minor2		
Conflicting Flow All	144	0	0	206	0	0	391	394	208	384	397	146
Stage 1	-	-	-	-	-	-	248	248	-	145	145	-
Stage 2	-	-	-	-	-	-	143	146	-	239	252	-
Critical Hdwy	4.12	-	-	4.12	-	-	7.12	6.52	6.22	7.12	6.52	6.22
Critical Hdwy Stg 1	-	-	-	-	-	-	6.12	5.52	-	6.12	5.52	-
Critical Hdwy Stg 2	-	-	-	-	-	-	6.12	5.52	-	6.12	5.52	-
Follow-up Hdwy	2,218	-	-	2,218	-	-	3,518	4,018	3,318	3,518	4,018	3,318
Pot Cap-1 Maneuver	1438	-	-	1365	-	-	568	542	832	574	540	901
Stage 1	-	-	-	-	-	-	756	701	-	858	777	-
Stage 2	-	-	-	-	-	-	860	776	-	764	698	-
Platoon blocked, %	-	-	-	-	-	-	-	-	-	-	-	-
Mov Cap-1 Maneuver	1412	-	-	1345	-	-	527	514	816	548	512	883
Mov Cap-2 Maneuver	-	-	-	-	-	-	527	514	-	548	512	-
Stage 1	-	-	-	-	-	-	732	678	-	827	762	-
Stage 2	-	-	-	-	-	-	821	761	-	739	675	-

Approach	EB	WB	NB	SB
HCM Control Delay, s	0.8	0.1	10.7	9.7
HCM LOS			B	A

Minor Lane/Major Mvmt	NBLn1	EBL	EBT	EBR	WBL	WBT	WBR	SBLn1
Capacity (veh/h)	650	1412	-	-	1345	-	-	805
HCM Lane V/C Ratio	0.023	0.016	-	-	0.001	-	-	0.055
HCM Control Delay (s)	10.7	7.6	0	-	7.7	0	-	9.7
HCM Lane LOS	B	A	A	-	A	A	-	A
HCM 95th %tile Q(veh)	0.1	0.1	-	-	0	-	-	0.2

HCM 2010 AWSC
3: Prestone & Centrum

PM Peak Hour
2028 Future Background

Intersection						
Intersection Delay, s/veh	8					
Intersection LOS	A					
Movement						
Movement	EBT	EBR	WBL	WBT	NBL	NBR
Lane Configurations	↔			↔	↔	
Traffic Vol, veh/h	39	108	53	18	72	37
Future Vol, veh/h	39	108	53	18	72	37
Peak Hour Factor	1.00	1.00	1.00	1.00	1.00	1.00
Heavy Vehicles, %	2	6	2	2	11	2
Mvmt Flow	39	108	53	18	72	37
Number of Lanes	1	0	0	1	1	1
Approach						
Approach	EB	WB		NB		
Opposing Approach	WB	EB				
Opposing Lanes	1	1		0		
Conflicting Approach Left		NB		EB		
Conflicting Lanes Left	0	2		1		
Conflicting Approach Right	NB			WB		
Conflicting Lanes Right	2	0		1		
HCM Control Delay	7.6	8		8.5		
HCM LOS	A	A		A		
Lane						
Lane	NBLn1	NBLn2	EBLn1	WBLn1		
Vol Left, %	100%	0%	0%	75%		
Vol Thru, %	0%	0%	27%	25%		
Vol Right, %	0%	100%	73%	0%		
Sign Control	Stop	Stop	Stop	Stop		
Traffic Vol by Lane	72	37	147	71		
LT Vol	72	0	0	53		
Through Vol	0	0	39	18		
RT Vol	0	37	108	0		
Lane Flow Rate	72	37	147	71		
Geometry Grp	7	7	2	2		
Degree of Util (X)	0.113	0.044	0.158	0.089		
Departure Headway (Hd)	5.665	4.307	3.86	4.511		
Convergence, Y/N	Yes	Yes	Yes	Yes		
Cap	636	837	933	797		
Service Time	3.365	2.007	1.868	2.522		
HCM Lane V/C Ratio	0.113	0.044	0.158	0.089		
HCM Control Delay	9.1	7.2	7.6	8		
HCM Lane LOS	A	A	A	A		
HCM 95th-tile Q	0.4	0.1	0.6	0.3		

HCM 2010 TWSC
4: Centrum & Brisebois E

PM Peak Hour
2028 Future Background

Intersection						
Int Delay, s/veh	1.7					
Movement						
Movement	EBL	EBT	WBT	WBR	SBL	SBR
Lane Configurations		↔			↔	
Traffic Vol, veh/h	8	49	39	0	0	16
Future Vol, veh/h	8	49	39	0	0	16
Conflicting Peds, #/hr	0	0	0	0	0	0
Sign Control	Free	Free	Free	Free	Stop	Stop
RT Channelized	-	None	-	None	-	None
Storage Length	-	-	-	-	0	-
Veh in Median Storage, #	-	0	0	-	0	-
Grade, %	-	0	0	-	0	-
Peak Hour Factor	100	100	100	100	100	100
Heavy Vehicles, %	2	2	2	2	2	2
Mvmt Flow	8	49	39	0	0	16
Major/Minor						
Major/Minor	Major1	Major2	Minor2			
Conflicting Flow All	39	0	0	104	39	
Stage 1	-	-	-	39	-	
Stage 2	-	-	-	65	-	
Critical Hdwy	4.12	-	-	6.42	6.22	
Critical Hdwy Stg 1	-	-	-	5.42	-	
Critical Hdwy Stg 2	-	-	-	5.42	-	
Follow-up Hdwy	2,218	-	-	3,518	3,318	
Pot Cap-1 Maneuver	1571	-	-	894	1033	
Stage 1	-	-	-	983	-	
Stage 2	-	-	-	958	-	
Platoon blocked, %	-	-	-	-	-	
Mov Cap-1 Maneuver	1571	-	-	890	1033	
Mov Cap-2 Maneuver	-	-	-	890	-	
Stage 1	-	-	-	978	-	
Stage 2	-	-	-	958	-	
Approach						
Approach	EB	WB	SB			
HCM Control Delay, s	1	0	8.5			
HCM LOS			A			
Minor Lane/Major Mvmt						
Minor Lane/Major Mvmt	EBL	EBT	WBT	WBR	SBLn1	SBRn1
Capacity (veh/h)	1571	-	-	-	1033	
HCM Lane V/C Ratio	0.005	-	-	-	0.015	
HCM Control Delay (s)	7.3	0	-	-	8.5	
HCM Lane LOS	A	A	-	-	A	
HCM 95th %tile Q(veh)	0	-	-	-	0	

Lanes, Volumes, Timings
5: Prestone & St Joseph

PM Peak Hour
2028 Future Background

Lane Group	EBL	EBT	EBR	WBL	WBT	WBR	NBL	NBT	NBR	SBL	SBT	SBR
Lane Configurations	↔	↕	↔	↔	↕	↔	↔	↕	↔	↔	↕	↔
Traffic Volume (vph)	26	861	116	10	476	106	57	28	9	130	75	26
Future Volume (vph)	26	861	116	10	476	106	57	28	9	130	75	26
Satd. Flow (prot)	1658	3316	1483	1658	3316	1483	1658	1572	0	1658	1567	0
Fit Permitted	0.480			0.309			0.692			0.733		
Satd. Flow (perm)	837	3316	1444	538	3316	1464	1201	1572	0	1278	1567	0
Satd. Flow (RTOR)			116			106		9			22	
Lane Group Flow (vph)	26	861	116	10	476	106	57	37	0	130	101	0
Turn Type	Perm	NA	Perm	Perm	NA	Perm	Perm	NA	NA	Perm	NA	
Protected Phases		2			6		8		8		4	
Permitted Phases	2		2	6		6	8			4		
Detector Phase	2	2	2	6	6	6	8	8		4	4	
Switch Phase												
Minimum Initial (s)	10.0	10.0	10.0	10.0	10.0	10.0	10.0	10.0		10.0	10.0	
Minimum Split (s)	23.7	23.7	23.7	23.7	23.7	23.7	29.0	29.0		29.0	29.0	
Total Split (s)	51.0	51.0	51.0	51.0	51.0	51.0	29.0	29.0		29.0	29.0	
Total Split (%)	63.8%	63.8%	63.8%	63.8%	63.8%	63.8%	36.3%	36.3%		36.3%	36.3%	
Yellow Time (s)	3.3	3.3	3.3	3.3	3.3	3.3	3.3	3.3		3.3	3.3	
All-Red Time (s)	2.4	2.4	2.4	2.4	2.4	2.4	2.7	2.7		2.7	2.7	
Lost Time Adjust (s)	0.0	0.0	0.0	0.0	0.0	0.0	0.0	0.0		0.0	0.0	
Total Lost Time (s)	5.7	5.7	5.7	5.7	5.7	5.7	6.0	6.0		6.0	6.0	
Lead/Lag												
Lead-Lag Optimize?												
Recall Mode	Max	Max	Max	Max	Max	Max	None	None		None	None	
Act Effct Green (s)	48.3	48.3	48.3	48.3	48.3	48.3	13.9	13.9		13.9	13.9	
Actuated g/C Ratio	0.65	0.65	0.65	0.65	0.65	0.65	0.19	0.19		0.19	0.19	
v/c Ratio	0.05	0.40	0.12	0.03	0.22	0.11	0.25	0.12		0.54	0.32	
Control Delay	6.5	7.4	1.9	6.7	6.2	1.9	26.4	19.3		34.5	21.7	
Queue Delay	0.0	0.0	0.0	0.0	0.0	0.0	0.0	0.0		0.0	0.0	
Total Delay	6.5	7.4	1.9	6.7	6.2	1.9	26.4	19.3		34.5	21.7	
LOS	A	A	A	A	A	A	C	B		C	C	
Approach Delay		6.7			5.5			23.6			28.9	
Approach LOS		A			A			C			C	
Queue Length 50th (m)	1.0	23.1	0.0	0.4	11.1	0.0	6.5	3.1		15.6	9.0	
Queue Length 95th (m)	4.9	50.2	6.2	2.7	25.5	6.0	15.2	9.7		30.2	20.5	
Internal Link Dist (m)		163.5			149.6			92.4			92.1	
Turn Bay Length (m)	50.0		105.0	62.5		120.0	47.5					
Base Capacity (vph)	546	2165	983	351	2165	992	375	498		399	505	
Starvation Cap Reductn	0	0	0	0	0	0	0	0		0	0	
Spillback Cap Reductn	0	0	0	0	0	0	0	0		0	0	
Storage Cap Reductn	0	0	0	0	0	0	0	0		0	0	
Reduced v/c Ratio	0.05	0.40	0.12	0.03	0.22	0.11	0.15	0.07		0.33	0.20	

Intersection Summary

Cycle Length: 80
Actuated Cycle Length: 74
Natural Cycle: 55
Control Type: Actuated-Uncoordinated
Maximum v/c Ratio: 0.54

Lanes, Volumes, Timings
5: Prestone & St Joseph

PM Peak Hour
2028 Future Background

Intersection Signal Delay: 9.8
Intersection Capacity Utilization 50.0%
Analysis Period (min) 15

Intersection LOS: A
ICU Level of Service A

Splits and Phases: 5: Prestone & St Joseph

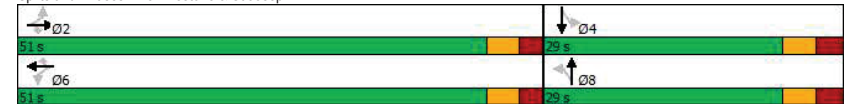

Appendix H

Synchro Intersection Worksheets – 2033 Future Background Conditions

Lanes, Volumes, Timings
1: Place d'Orleans & Centrum

AM Peak Hour
2033 Future Background

Lane Group	EBL	EBT	EBR	WBL	WBT	WBR	NBL	NBT	NBR	SBL	SBT	SBR
Lane Configurations	↔	↔	↔	↔	↔	↔	↔	↔	↔	↔	↔	↔
Traffic Volume (vph)	25	31	40	22	33	1	67	176	52	110	42	19
Future Volume (vph)	25	31	40	22	33	1	67	176	52	110	42	19
Satd. Flow (prot)	1566	1745	1401	1658	1721	0	0	3157	0	0	3025	0
Fit Permitted	0.735			0.737				0.857			0.690	
Satd. Flow (perm)	1203	1745	1375	1278	1721	0	0	2735	0	0	2154	0
Satd. Flow (RTOR)			44		1			48			19	
Lane Group Flow (vph)	25	31	40	22	34	0	0	295	0	0	171	0
Turn Type	Perm	NA	Perm	Perm	NA	Perm	NA	Perm	NA	Perm	NA	
Protected Phases	4			8			2	2		6		6
Permitted Phases	4		4	8			2			6		6
Detector Phase	4	4	4	8	8		2	2		6	6	6
Switch Phase												
Minimum Initial (s)	10.0	10.0	10.0	10.0	10.0		10.0	10.0		10.0	10.0	
Minimum Split (s)	31.0	31.0	31.0	31.0	31.0		36.0	36.0		36.0	36.0	
Total Split (s)	32.0	32.0	32.0	32.0	32.0		43.0	43.0		43.0	43.0	
Total Split (%)	42.7%	42.7%	42.7%	42.7%	42.7%		57.3%	57.3%		57.3%	57.3%	
Yellow Time (s)	3.3	3.3	3.3	3.3	3.3		3.3	3.3		3.3	3.3	
All-Red Time (s)	2.7	2.7	2.7	2.7	2.7		2.7	2.7		2.7	2.7	
Lost Time Adjust (s)	0.0	0.0	0.0	0.0	0.0		0.0	0.0		0.0	0.0	
Total Lost Time (s)	6.0	6.0	6.0	6.0	6.0		6.0	6.0		6.0	6.0	
Lead/Lag												
Lead-Lag Optimize?												
Recall Mode	None	None	None	None	None		Max	Max		Max	Max	
Act Effct Green (s)	12.6	12.6	12.6	12.6	12.6		46.3	46.3		46.3	46.3	
Actuated g/C Ratio	0.20	0.20	0.20	0.20	0.20		0.75	0.75		0.75	0.75	
v/c Ratio	0.10	0.09	0.13	0.08	0.10		0.14	0.14		0.11	0.11	
Control Delay	20.0	19.5	7.0	19.6	19.2		4.9	4.9		5.4	5.4	
Queue Delay	0.0	0.0	0.0	0.0	0.0		0.0	0.0		0.0	0.0	
Total Delay	20.0	19.5	7.0	19.6	19.2		4.9	4.9		5.4	5.4	
LOS	B	B	A	B	B		A	A		A	A	
Approach Delay		14.4			19.4		4.9	4.9		5.4	5.4	
Approach LOS		B			B		A	A		A	A	
Queue Length 50th (m)	2.3	2.9	0.0	2.0	3.1		4.8	4.8		2.8	2.8	
Queue Length 95th (m)	7.2	8.2	5.5	6.5	8.6		15.8	15.8		10.6	10.6	
Internal Link Dist (m)		55.7			119.8		103.0	103.0		90.8	90.8	
Turn Bay Length (m)	52.0		20.0									
Base Capacity (vph)	512	743	610	544	733		2065	2065		1622	1622	
Starvation Cap Reductn	0	0	0	0	0		0	0		0	0	
Spillback Cap Reductn	0	0	0	0	0		0	0		0	0	
Storage Cap Reductn	0	0	0	0	0		0	0		0	0	
Reduced v/c Ratio	0.05	0.04	0.07	0.04	0.05		0.14	0.14		0.11	0.11	

Intersection Summary

Cycle Length: 75
 Actuated Cycle Length: 61.6
 Natural Cycle: 70
 Control Type: Actuated-Uncoordinated
 Maximum v/c Ratio: 0.14

Lanes, Volumes, Timings
1: Place d'Orleans & Centrum

AM Peak Hour
2033 Future Background

Intersection Signal Delay: 7.8
 Intersection Capacity Utilization 60.2%
 Analysis Period (min) 15
 Intersection LOS: A
 ICU Level of Service B

Splits and Phases: 1: Place d'Orleans & Centrum



HCM 2010 TWSC
2: Centrum & Brisebois W

AM Peak Hour
2033 Future Background

Intersection												
Int Delay, s/veh	1.3											
Movement	EBL	EBT	EBR	WBL	WBT	WBR	NBL	NBT	NBR	SBL	SBT	SBR
Lane Configurations	↕			↕			↕			↕		
Traffic Vol, veh/h	24	82	10	2	127	3	0	0	1	1	0	13
Future Vol, veh/h	24	82	10	2	127	3	0	0	1	1	0	13
Conflicting Peds, #/hr	8	0	9	9	0	8	0	0	3	3	0	0
Sign Control	Free	Free	Free	Free	Free	Free	Stop	Stop	Stop	Stop	Stop	Stop
RT Channelized	-	-	None	-	-	None	-	-	None	-	-	None
Storage Length	-	-	-	-	-	-	-	-	-	-	-	-
Veh in Median Storage, #	-	0	-	-	0	-	-	0	-	-	0	-
Grade, %	-	0	-	-	0	-	-	0	-	-	0	-
Peak Hour Factor	100	100	100	100	100	100	100	100	100	100	100	100
Heavy Vehicles, %	2	5	2	2	3	2	2	2	100	2	2	2
Mvmt Flow	24	82	10	2	127	3	0	0	1	1	0	13
Major/Minor	Major1			Major2			Minor1			Minor2		
Conflicting Flow All	138	0	0	101	0	0	283	286	99	280	290	137
Stage 1	-	-	-	-	-	-	144	144	-	141	141	-
Stage 2	-	-	-	-	-	-	139	142	-	139	149	-
Critical Hdwy	4.12	-	-	4.12	-	-	7.12	6.52	7.2	7.12	6.52	6.22
Critical Hdwy Stg 1	-	-	-	-	-	-	6.12	5.52	-	6.12	5.52	-
Critical Hdwy Stg 2	-	-	-	-	-	-	6.12	5.52	-	6.12	5.52	-
Follow-up Hdwy	2,218	-	-	2,218	-	-	3,518	4,018	4.2	3,518	4,018	3,318
Pot Cap-1 Maneuver	1446	-	-	1491	-	-	669	623	745	672	620	911
Stage 1	-	-	-	-	-	-	859	778	-	862	780	-
Stage 2	-	-	-	-	-	-	864	779	-	864	774	-
Platoon blocked, %	-	-	-	-	-	-	-	-	-	-	-	-
Mov Cap-1 Maneuver	1437	-	-	1481	-	-	646	603	738	656	600	905
Mov Cap-2 Maneuver	-	-	-	-	-	-	646	603	-	656	600	-
Stage 1	-	-	-	-	-	-	838	759	-	841	775	-
Stage 2	-	-	-	-	-	-	851	774	-	845	755	-
Approach	EB			WB			NB			SB		
HCM Control Delay, s	1.6			0.1			9.9			9.2		
HCM LOS	A			A			A			A		
Minor Lane/Major Mvmt	NBLn1	EBL	EBT	EBR	WBL	WBT	WBR	SBLn1				
Capacity (veh/h)	738	1437	-	-	1481	-	-	881				
HCM Lane V/C Ratio	0.001	0.017	-	-	0.001	-	-	0.016				
HCM Control Delay (s)	9.9	7.5	0	-	7.4	0	-	9.2				
HCM Lane LOS	A	A	A	-	A	A	-	A				
HCM 95th %tile Q(veh)	0	0.1	-	-	0	-	-	0				

HCM 2010 AWSC
3: Prestone & Centrum

AM Peak Hour
2033 Future Background

Intersection						
Intersection Delay, s/veh	7.7					
Intersection LOS	A					
Movement	EBT	EBR	WBL	WBT	NBL	NBR
Lane Configurations	↕			↕	↕	↕
Traffic Vol, veh/h	21	41	39	18	55	36
Future Vol, veh/h	21	41	39	18	55	36
Peak Hour Factor	1.00	1.00	1.00	1.00	1.00	1.00
Heavy Vehicles, %	5	17	2	6	7	2
Mvmt Flow	21	41	39	18	55	36
Number of Lanes	1	0	0	1	1	1
Approach	EB		WB		NB	
Opposing Approach	WB		EB			
Opposing Lanes	1		1		0	
Conflicting Approach Left			NB		EB	
Conflicting Lanes Left	0		2		1	
Conflicting Approach Right	NB				WB	
Conflicting Lanes Right	2		0		1	
HCM Control Delay	7.1		7.7		8	
HCM LOS	A		A		A	
Lane	NBLn1	NBLn2	EBLn1	WBLn1		
Vol Left, %	100%	0%	0%	68%		
Vol Thru, %	0%	0%	34%	32%		
Vol Right, %	0%	100%	66%	0%		
Sign Control	Stop	Stop	Stop	Stop		
Traffic Vol by Lane	55	36	62	57		
LT Vol	55	0	0	39		
Through Vol	0	0	21	18		
RT Vol	0	36	41	0		
Lane Flow Rate	55	36	62	57		
Geometry Grp	7	7	2	2		
Degree of Util (X)	0.081	0.04	0.065	0.068		
Departure Headway (Hd)	5.326	4.039	3.787	4.274		
Convergence, Y/N	Yes	Yes	Yes	Yes		
Cap	670	881	929	827		
Service Time	3.078	1.791	1.877	2.358		
HCM Lane V/C Ratio	0.082	0.041	0.067	0.069		
HCM Control Delay	8.6	7	7.1	7.7		
HCM Lane LOS	A	A	A	A		
HCM 95th %tile Q	0.3	0.1	0.2	0.2		

HCM 2010 TWSC
4: Centrum & Brisebois E

AM Peak Hour
2033 Future Background

Intersection						
Int Delay, s/veh	2					
Movement	EBL	EBT	WBT	WBR	SBL	SBR
Lane Configurations		↕	↕		↕	↕
Traffic Vol, veh/h	11	19	27	1	0	5
Future Vol, veh/h	11	19	27	1	0	5
Conflicting Peds, #/hr	0	0	0	0	0	0
Sign Control	Free	Free	Free	Free	Stop	Stop
RT Channelized	-	None	-	None	-	None
Storage Length	-	-	-	-	0	-
Veh in Median Storage, #	-	0	0	-	0	-
Grade, %	-	0	0	-	0	-
Peak Hour Factor	100	100	100	100	100	100
Heavy Vehicles, %	9	2	2	2	2	20
Mvmt Flow	11	19	27	1	0	5
Major/Minor	Major1	Major2	Minor2			
Conflicting Flow All	28	0	0	69	28	
Stage 1	-	-	-	28	-	
Stage 2	-	-	-	41	-	
Critical Hdwy	4.19	-	-	6.42	6.4	
Critical Hdwy Stg 1	-	-	-	5.42	-	
Critical Hdwy Stg 2	-	-	-	5.42	-	
Follow-up Hdwy	2.281	-	-	3.518	3.48	
Pot Cap-1 Maneuver	1541	-	-	936	998	
Stage 1	-	-	-	995	-	
Stage 2	-	-	-	981	-	
Platoon blocked, %	-	-	-	-	-	
Mov Cap-1 Maneuver	1541	-	-	929	998	
Mov Cap-2 Maneuver	-	-	-	929	-	
Stage 1	-	-	-	988	-	
Stage 2	-	-	-	981	-	
Approach	EB	WB	SB			
HCM Control Delay, s	2.7	0	8.6			
HCM LOS			A			
Minor Lane/Major Mvmt	EBL	EBT	WBT	WBR	SBLn1	
Capacity (veh/h)	1541	-	-	-	998	
HCM Lane V/C Ratio	0.007	-	-	-	0.005	
HCM Control Delay (s)	7.4	0	-	-	8.6	
HCM Lane LOS	A	A	-	-	A	
HCM 95th %tile Q(veh)	0	-	-	-	0	

Lanes, Volumes, Timings
5: Prestone & St Joseph

AM Peak Hour
2033 Future Background



Lane Group	EBL	EBT	EBR	WBL	WBT	WBR	NBL	NBT	NBR	SBL	SBT	SBR
Lane Configurations	↕	↕	↕	↕	↕	↕	↕	↕	↕	↕	↕	↕
Traffic Volume (vph)	7	179	40	2	848	103	81	46	5	40	26	12
Future Volume (vph)	7	179	40	2	848	103	81	46	5	40	26	12
Satd. Flow (prot)	1658	3316	1375	1658	3316	1441	1626	1687	0	1566	1314	0
Fit Permitted	0.234			0.639			0.732			0.724		
Satd. Flow (perm)	408	3316	1375	1115	3316	1423	1252	1687	0	1191	1314	0
Satd. Flow (RTOR)			41			103		5				12
Lane Group Flow (vph)	7	179	40	2	848	103	81	51	0	40	38	0
Turn Type	Perm	NA	Perm	Perm	NA	Perm	Perm	NA		Perm	NA	
Protected Phases		2			6			8				4
Permitted Phases	2		2	6		6	8				4	
Detector Phase	2	2	2	6	6	6	8	8			4	4
Switch Phase												
Minimum Initial (s)	10.0	10.0	10.0	10.0	10.0	10.0	10.0	10.0		10.0	10.0	
Minimum Split (s)	23.7	23.7	23.7	23.7	23.7	23.7	29.0	29.0		29.0	29.0	
Total Split (s)	51.0	51.0	51.0	51.0	51.0	51.0	29.0	29.0		29.0	29.0	
Total Split (%)	63.8%	63.8%	63.8%	63.8%	63.8%	63.8%	36.3%	36.3%		36.3%	36.3%	
Yellow Time (s)	3.3	3.3	3.3	3.3	3.3	3.3	3.3	3.3		3.3	3.3	
All-Red Time (s)	2.4	2.4	2.4	2.4	2.4	2.4	2.7	2.7		2.7	2.7	
Lost Time Adjust (s)	0.0	0.0	0.0	0.0	0.0	0.0	0.0	0.0		0.0	0.0	
Total Lost Time (s)	5.7	5.7	5.7	5.7	5.7	5.7	6.0	6.0		6.0	6.0	
Lead/Lag												
Lead-Lag Optimize?												
Recall Mode	None	None	None	None	None	None	Max	Max		Max	Max	
Act Effct Green (s)	19.6	19.6	19.6	19.6	19.6	19.6	23.2	23.2		23.2	23.2	
Actuated g/C Ratio	0.36	0.36	0.36	0.36	0.36	0.36	0.42	0.42		0.42	0.42	
v/c Ratio	0.05	0.15	0.08	0.01	0.71	0.18	0.15	0.07		0.08	0.07	
Control Delay	11.4	11.6	4.3	10.5	18.5	3.6	12.3	10.6		11.8	9.2	
Queue Delay	0.0	0.0	0.0	0.0	0.0	0.0	0.0	0.0		0.0	0.0	
Total Delay	11.4	11.6	4.3	10.5	18.5	3.6	12.3	10.6		11.8	9.2	
LOS	B	B	A	B	B	A	B	B		B	A	
Approach Delay		10.3			16.9		11.7				10.5	
Approach LOS		B			B		B				B	
Queue Length 50th (m)	0.4	6.0	0.0	0.1	36.4	0.0	4.6	2.5		2.2	1.4	
Queue Length 95th (m)	2.4	11.0	4.3	1.1	52.0	6.9	14.0	9.1		8.2	6.8	
Internal Link Dist (m)		163.5			149.6		92.4				92.1	
Turn Bay Length (m)	50.0		105.0	62.5		120.0	47.5					
Base Capacity (vph)	341	2772	1156	932	2772	1206	531	718		505	564	
Starvation Cap Reductn	0	0	0	0	0	0	0	0		0	0	
Spillback Cap Reductn	0	0	0	0	0	0	0	0		0	0	
Storage Cap Reductn	0	0	0	0	0	0	0	0		0	0	
Reduced v/c Ratio	0.02	0.06	0.03	0.00	0.31	0.09	0.15	0.07		0.08	0.07	

Intersection Summary	
Cycle Length:	80
Actuated Cycle Length:	54.6
Natural Cycle:	55
Control Type:	Actuated-Uncoordinated
Maximum v/c Ratio:	0.71

Lanes, Volumes, Timings
5: Prestone & St Joseph

AM Peak Hour
2033 Future Background

Intersection Signal Delay: 15.0 Intersection LOS: B
Intersection Capacity Utilization 53.7% ICU Level of Service A
Analysis Period (min) 15

Splits and Phases: 5: Prestone & St Joseph



Lanes, Volumes, Timings
1: Place d'Orleans & Centrum

PM Peak Hour
2033 Future Background

Lane Group	EBL	EBT	EBR	WBL	WBT	WBR	NBL	NBT	NBR	SBL	SBT	SBR
Lane Configurations	↔	↕	↗	↖	↖	↗	↕	↕	↗	↖	↖	↗
Traffic Volume (vph)	94	57	220	41	46	0	102	153	65	108	158	42
Future Volume (vph)	94	57	220	41	46	0	102	153	65	108	158	42
Satd. Flow (prot)	1658	1745	1483	1658	1745	0	0	3104	0	0	3115	0
Fit Permitted	0.727			0.720				0.758			0.740	
Satd. Flow (perm)	1252	1745	1448	1242	1745	0	0	2388	0	0	2341	0
Satd. Flow (RTOR)			220					60			33	
Lane Group Flow (vph)	94	57	220	41	46	0	0	320	0	0	308	0
Turn Type	Perm	NA	Perm	Perm	NA		Perm	NA		Perm	NA	
Protected Phases		4			8			2			6	
Permitted Phases	4		4	8			2			6		
Detector Phase	4	4	4	8	8		2	2		6	6	
Switch Phase												
Minimum Initial (s)	10.0	10.0	10.0	10.0	10.0		10.0	10.0		10.0	10.0	
Minimum Split (s)	31.0	31.0	31.0	31.0	31.0		36.0	36.0		36.0	36.0	
Total Split (s)	32.0	32.0	32.0	32.0	32.0		53.0	53.0		53.0	53.0	
Total Split (%)	37.6%	37.6%	37.6%	37.6%	37.6%		62.4%	62.4%		62.4%	62.4%	
Yellow Time (s)	3.3	3.3	3.3	3.3	3.3		3.3	3.3		3.3	3.3	
All-Red Time (s)	2.7	2.7	2.7	2.7	2.7		2.7	2.7		2.7	2.7	
Lost Time Adjust (s)	0.0	0.0	0.0	0.0	0.0		0.0	0.0		0.0	0.0	
Total Lost Time (s)	6.0	6.0	6.0	6.0	6.0		6.0	6.0		6.0	6.0	
Lead/Lag												
Lead-Lag Optimize?												
Recall Mode	None	None	None	None	None		C-Max	C-Max		C-Max	C-Max	
Act Effct Green (s)	14.1	14.1	14.1	14.1	14.1		58.9	58.9		58.9	58.9	
Actuated g/C Ratio	0.17	0.17	0.17	0.17	0.17		0.69	0.69		0.69	0.69	
v/c Ratio	0.45	0.20	0.52	0.20	0.16		0.19	0.19		0.19	0.19	
Control Delay	37.3	29.8	8.6	30.3	29.0		4.9	5.3		4.9	5.3	
Queue Delay	0.0	0.0	0.0	0.0	0.0		0.0	0.0		0.0	0.0	
Total Delay	37.3	29.8	8.6	30.3	29.0		4.9	5.3		4.9	5.3	
LOS	D	C	A	C	C		A	A		A	A	
Approach Delay		19.1			29.6		4.9	5.3		4.9	5.3	
Approach LOS		B			C		A	A		A	A	
Queue Length 50th (m)	14.4	8.4	0.0	6.0	6.7		5.7	6.1		5.7	6.1	
Queue Length 95th (m)	23.7	15.2	15.1	12.3	13.0		16.6	17.3		16.6	17.3	
Internal Link Dist (m)		55.7			119.8		103.0	90.8		103.0	90.8	
Turn Bay Length (m)	52.0		20.0									
Base Capacity (vph)	382	533	595	379	533		1672	1631		1672	1631	
Starvation Cap Reductn	0	0	0	0	0		0	0		0	0	
Spillback Cap Reductn	0	0	0	0	0		0	0		0	0	
Storage Cap Reductn	0	0	0	0	0		0	0		0	0	
Reduced v/c Ratio	0.25	0.11	0.37	0.11	0.09		0.19	0.19		0.19	0.19	

Intersection Summary

Cycle Length: 85
Actuated Cycle Length: 85
Offset: 0 (0%), Referenced to phase 2:NBTL and 6:SBTL, Start of Green
Natural Cycle: 70
Control Type: Actuated-Coordinated

Lanes, Volumes, Timings
1: Place d'Orleans & Centrum

PM Peak Hour
2033 Future Background

Maximum v/c Ratio: 0.52	Intersection LOS: B
Intersection Signal Delay: 11.8	ICU Level of Service D
Intersection Capacity Utilization 80.0%	
Analysis Period (min) 15	

Splits and Phases: 1: Place d'Orleans & Centrum

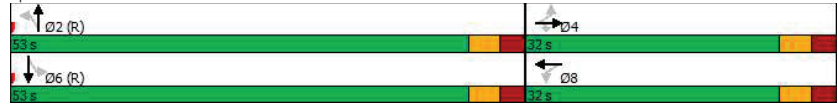

HCM 2010 TWSC
2: Centrum & Brisebois W

PM Peak Hour
2033 Future Background

Intersection												
Int Delay, s/veh	1.9											
Movement	EBL	EBT	EBR	WBL	WBT	WBR	NBL	NBT	NBR	SBL	SBT	SBR
Lane Configurations	↔			↔			↕			↕		
Traffic Vol, veh/h	23	181	8	1	120	3	7	0	8	7	0	37
Future Vol, veh/h	23	181	8	1	120	3	7	0	8	7	0	37
Conflicting Peds, #/hr	23	0	19	19	0	23	3	0	6	6	0	3
Sign Control	Free	Free	Free	Free	Free	Free	Stop	Stop	Stop	Stop	Stop	Stop
RT Channelized	-	-	None	-	-	None	-	-	None	-	-	None
Storage Length	-	-	-	-	-	-	-	-	-	-	-	-
Veh in Median Storage, #	-	0	-	-	0	-	-	0	-	-	0	-
Grade, %	-	0	-	-	0	-	-	0	-	-	0	-
Peak Hour Factor	100	100	100	100	100	100	100	100	100	100	100	100
Heavy Vehicles, %	2	3	2	2	5	2	2	2	2	2	2	2
Mvmt Flow	23	181	8	1	120	3	7	0	8	7	0	37
Major/Minor	Major1			Major2			Minor1			Minor2		
Conflicting Flow All	146	0	0	208	0	0	395	398	210	388	401	148
Stage 1	-	-	-	-	-	-	250	250	-	147	147	-
Stage 2	-	-	-	-	-	-	145	148	-	241	254	-
Critical Hdwy	4.12	-	-	4.12	-	-	7.12	6.52	6.22	7.12	6.52	6.22
Critical Hdwy Stg 1	-	-	-	-	-	-	6.12	5.52	-	6.12	5.52	-
Critical Hdwy Stg 2	-	-	-	-	-	-	6.12	5.52	-	6.12	5.52	-
Follow-up Hdwy	2,218	-	-	2,218	-	-	3,518	4,018	3,318	3,518	4,018	3,318
Pot Cap-1 Maneuver	1436	-	-	1363	-	-	565	540	830	571	538	899
Stage 1	-	-	-	-	-	-	754	700	-	856	775	-
Stage 2	-	-	-	-	-	-	858	775	-	762	697	-
Platoon blocked, %	-	-	-	-	-	-	-	-	-	-	-	-
Mov Cap-1 Maneuver	1410	-	-	1343	-	-	524	512	814	545	511	881
Mov Cap-2 Maneuver	-	-	-	-	-	-	524	512	-	545	511	-
Stage 1	-	-	-	-	-	-	730	677	-	825	760	-
Stage 2	-	-	-	-	-	-	819	760	-	737	674	-
Approach	EB			WB			NB			SB		
HCM Control Delay, s	0.8			0.1			10.7			9.7		
HCM LOS							B			A		
Minor Lane/Major Mvmt	NBLn1	EBL	EBT	EBR	WBL	WBT	WBR	SBLn1				
Capacity (veh/h)	647	1410	-	-	1343	-	-	802				
HCM Lane V/C Ratio	0.023	0.016	-	-	0.001	-	-	0.055				
HCM Control Delay (s)	10.7	7.6	0	-	7.7	0	-	9.7				
HCM Lane LOS	B	A	A	-	A	A	-	A				
HCM 95th %tile Q(veh)	0.1	0.1	-	-	0	-	-	0.2				

HCM 2010 AWSC
3: Prestone & Centrum

PM Peak Hour
2033 Future Background

Intersection						
Intersection Delay, s/veh	8					
Intersection LOS	A					
Movement	EBT	EBR	WBL	WBT	NBL	NBR
Lane Configurations	↶			↷	↶	↷
Traffic Vol, veh/h	40	108	53	18	72	37
Future Vol, veh/h	40	108	53	18	72	37
Peak Hour Factor	1.00	1.00	1.00	1.00	1.00	1.00
Heavy Vehicles, %	2	6	2	2	11	2
Mvmt Flow	40	108	53	18	72	37
Number of Lanes	1	0	0	1	1	1
Approach	EB	WB		NB		
Opposing Approach	WB	EB				
Opposing Lanes	1	1		0		
Conflicting Approach Left		NB		EB		
Conflicting Lanes Left	0	2		1		
Conflicting Approach Right	NB			WB		
Conflicting Lanes Right	2	0		1		
HCM Control Delay	7.6	8		8.5		
HCM LOS	A	A		A		
Lane	NBLn1	NBLn2	EBLn1	WBLn1		
Vol Left, %	100%	0%	0%	75%		
Vol Thru, %	0%	0%	27%	25%		
Vol Right, %	0%	100%	73%	0%		
Sign Control	Stop	Stop	Stop	Stop		
Traffic Vol by Lane	72	37	148	71		
LT Vol	72	0	0	53		
Through Vol	0	0	40	18		
RT Vol	0	37	108	0		
Lane Flow Rate	72	37	148	71		
Geometry Grp	7	7	2	2		
Degree of Util (X)	0.113	0.043	0.159	0.089		
Departure Headway (Hd)	5.667	4.209	3.863	4.513		
Convergence, Y/N	Yes	Yes	Yes	Yes		
Cap	636	836	932	797		
Service Time	3.367	2.008	1.869	2.522		
HCM Lane V/C Ratio	0.113	0.044	0.159	0.089		
HCM Control Delay	9.1	7.2	7.6	8		
HCM Lane LOS	A	A	A	A		
HCM 95th-tile Q	0.4	0.1	0.6	0.3		

HCM 2010 TWSC
4: Centrum & Brisebois E

PM Peak Hour
2033 Future Background

Intersection						
Int Delay, s/veh	1.7					
Movement	EBL	EBT	WBT	WBR	SBL	SBR
Lane Configurations		↶	↷		↶	↷
Traffic Vol, veh/h	8	49	40	0	0	16
Future Vol, veh/h	8	49	40	0	0	16
Conflicting Peds, #/hr	0	0	0	0	0	0
Sign Control	Free	Free	Free	Free	Stop	Stop
RT Channelized	-	None	-	None	-	None
Storage Length	-	-	-	-	0	-
Veh in Median Storage, #	-	0	0	-	0	-
Grade, %	-	0	0	-	0	-
Peak Hour Factor	100	100	100	100	100	100
Heavy Vehicles, %	2	2	2	2	2	2
Mvmt Flow	8	49	40	0	0	16
Major/Minor	Major1	Major2	Minor2			
Conflicting Flow All	40	0	0	105	40	
Stage 1	-	-	-	40	-	
Stage 2	-	-	-	65	-	
Critical Hdwy	4.12	-	-	6.42	6.22	
Critical Hdwy Stg 1	-	-	-	5.42	-	
Critical Hdwy Stg 2	-	-	-	5.42	-	
Follow-up Hdwy	2,218	-	-	3,518	3,318	
Pot Cap-1 Maneuver	1570	-	-	893	1031	
Stage 1	-	-	-	982	-	
Stage 2	-	-	-	958	-	
Platoon blocked, %	-	-	-	-	-	
Mov Cap-1 Maneuver	1570	-	-	889	1031	
Mov Cap-2 Maneuver	-	-	-	889	-	
Stage 1	-	-	-	977	-	
Stage 2	-	-	-	958	-	
Approach	EB	WB	SB			
HCM Control Delay, s	1	0	8.5			
HCM LOS			A			
Minor Lane/Major Mvmt	EBL	EBT	WBT	WBR	SBLn1	SBRn1
Capacity (veh/h)	1570	-	-	-	1031	-
HCM Lane V/C Ratio	0.005	-	-	-	0.016	-
HCM Control Delay (s)	7.3	0	-	-	8.5	-
HCM Lane LOS	A	A	-	-	A	-
HCM 95th %tile Q(veh)	0	-	-	-	0	-

Lanes, Volumes, Timings
5: Prestone & St Joseph

PM Peak Hour
2033 Future Background

Lane Group	EBL	EBT	EBR	WBL	WBT	WBR	NBL	NBT	NBR	SBL	SBT	SBR
Lane Configurations	↔	↕	↔	↔	↕	↔	↔	↕	↔	↔	↕	↔
Traffic Volume (vph)	26	947	116	10	481	106	57	28	9	130	75	26
Future Volume (vph)	26	947	116	10	481	106	57	28	9	130	75	26
Satd. Flow (prot)	1658	3316	1483	1658	3316	1483	1658	1572	0	1658	1567	0
Fit Permitted	0.477			0.276			0.692			0.733		
Satd. Flow (perm)	832	3316	1444	481	3316	1464	1201	1572	0	1278	1567	0
Satd. Flow (RTOR)			116			106		9			22	
Lane Group Flow (vph)	26	947	116	10	481	106	57	37	0	130	101	0
Turn Type	Perm	NA	Perm	Perm	NA	Perm	Perm	NA	NA	Perm	NA	
Protected Phases		2			6		8		8		4	
Permitted Phases	2		2	6		6	8			4		
Detector Phase	2	2	2	6	6	6	8	8		4	4	
Switch Phase												
Minimum Initial (s)	10.0	10.0	10.0	10.0	10.0	10.0	10.0	10.0		10.0	10.0	
Minimum Split (s)	23.7	23.7	23.7	23.7	23.7	23.7	29.0	29.0		29.0	29.0	
Total Split (s)	51.0	51.0	51.0	51.0	51.0	51.0	29.0	29.0		29.0	29.0	
Total Split (%)	63.8%	63.8%	63.8%	63.8%	63.8%	63.8%	36.3%	36.3%		36.3%	36.3%	
Yellow Time (s)	3.3	3.3	3.3	3.3	3.3	3.3	3.3	3.3		3.3	3.3	
All-Red Time (s)	2.4	2.4	2.4	2.4	2.4	2.4	2.7	2.7		2.7	2.7	
Lost Time Adjust (s)	0.0	0.0	0.0	0.0	0.0	0.0	0.0	0.0		0.0	0.0	
Total Lost Time (s)	5.7	5.7	5.7	5.7	5.7	5.7	6.0	6.0		6.0	6.0	
Lead/Lag												
Lead-Lag Optimize?												
Recall Mode	Max	Max	Max	Max	Max	Max	None	None		None	None	
Act Effct Green (s)	48.3	48.3	48.3	48.3	48.3	48.3	13.9	13.9		13.9	13.9	
Actuated g/C Ratio	0.65	0.65	0.65	0.65	0.65	0.65	0.19	0.19		0.19	0.19	
v/c Ratio	0.05	0.44	0.12	0.03	0.22	0.11	0.25	0.12		0.54	0.32	
Control Delay	6.5	7.8	1.9	6.8	6.2	1.9	26.4	19.3		34.5	21.7	
Queue Delay	0.0	0.0	0.0	0.0	0.0	0.0	0.0	0.0		0.0	0.0	
Total Delay	6.5	7.8	1.9	6.8	6.2	1.9	26.4	19.3		34.5	21.7	
LOS	A	A	A	A	A	A	C	B		C	C	
Approach Delay		7.1			5.5			23.6			28.9	
Approach LOS		A			A			C			C	
Queue Length 50th (m)	1.0	26.3	0.0	0.4	11.2	0.0	6.5	3.1		15.6	9.0	
Queue Length 95th (m)	4.9	56.7	6.2	2.7	25.8	6.0	15.2	9.7		30.2	20.5	
Internal Link Dist (m)		163.5			149.6			92.4			92.1	
Turn Bay Length (m)	50.0		105.0	62.5		120.0	47.5					
Base Capacity (vph)	543	2165	983	314	2165	992	375	498		399	505	
Starvation Cap Reductn	0	0	0	0	0	0	0	0		0	0	
Spillback Cap Reductn	0	0	0	0	0	0	0	0		0	0	
Storage Cap Reductn	0	0	0	0	0	0	0	0		0	0	
Reduced v/c Ratio	0.05	0.44	0.12	0.03	0.22	0.11	0.15	0.07		0.33	0.20	

Intersection Summary

Cycle Length: 80
Actuated Cycle Length: 74
Natural Cycle: 55
Control Type: Actuated-Uncoordinated
Maximum v/c Ratio: 0.54

Lanes, Volumes, Timings
5: Prestone & St Joseph

PM Peak Hour
2033 Future Background

Intersection Signal Delay: 9.9
Intersection Capacity Utilization 52.5%
Analysis Period (min) 15

Intersection LOS: A
ICU Level of Service A

Splits and Phases: 5: Prestone & St Joseph



Appendix I

Synchro Intersection Worksheets – 2028 Future Total Conditions

Lanes, Volumes, Timings
1: Place d'Orleans & Centrum

AM Peak Hour
2028 Future Total

Lane Group	EBL	EBT	EBR	WBL	WBT	WBR	NBL	NBT	NBR	SBL	SBT	SBR
Lane Configurations	↔	↔	↔	↔	↔	↔	↔	↔	↔	↔	↔	↔
Traffic Volume (vph)	25	65	40	34	81	4	67	158	62	112	42	19
Future Volume (vph)	25	65	40	34	81	4	67	158	62	112	42	19
Satd. Flow (prot)	1566	1745	1401	1658	1715	0	0	3137	0	0	3029	0
Fit Permitted	0.702			0.715				0.854			0.688	
Satd. Flow (perm)	1150	1745	1375	1241	1715	0	0	2711	0	0	2151	0
Satd. Flow (RTOR)			44		4			62			19	
Lane Group Flow (vph)	25	65	40	34	85	0	0	287	0	0	173	0
Turn Type	Perm	NA	Perm	Perm	NA	Perm	NA	Perm	NA	Perm	NA	
Protected Phases	4			8		8		2		6		6
Permitted Phases	4		4	8			2			6		6
Detector Phase	4	4	4	8	8		2	2		6	6	6
Switch Phase												
Minimum Initial (s)	10.0	10.0	10.0	10.0	10.0		10.0	10.0		10.0	10.0	
Minimum Split (s)	31.0	31.0	31.0	31.0	31.0		36.0	36.0		36.0	36.0	
Total Split (s)	32.0	32.0	32.0	32.0	32.0		43.0	43.0		43.0	43.0	
Total Split (%)	42.7%	42.7%	42.7%	42.7%	42.7%		57.3%	57.3%		57.3%	57.3%	
Yellow Time (s)	3.3	3.3	3.3	3.3	3.3		3.3	3.3		3.3	3.3	
All-Red Time (s)	2.7	2.7	2.7	2.7	2.7		2.7	2.7		2.7	2.7	
Lost Time Adjust (s)	0.0	0.0	0.0	0.0	0.0		0.0	0.0		0.0	0.0	
Total Lost Time (s)	6.0	6.0	6.0	6.0	6.0		6.0	6.0		6.0	6.0	
Lead/Lag												
Lead-Lag Optimize?												
Recall Mode	None	None	None	None	None		Max	Max		Max	Max	
Act Effct Green (s)	12.6	12.6	12.6	12.6	12.6		42.1	42.1		42.1	42.1	
Actuated g/C Ratio	0.20	0.20	0.20	0.20	0.20		0.68	0.68		0.68	0.68	
v/c Ratio	0.11	0.18	0.13	0.14	0.24		0.15	0.15		0.12	0.12	
Control Delay	20.2	21.0	7.0	20.6	21.0		5.2	5.2		6.0	6.0	
Queue Delay	0.0	0.0	0.0	0.0	0.0		0.0	0.0		0.0	0.0	
Total Delay	20.2	21.0	7.0	20.6	21.0		5.2	5.2		6.0	6.0	
LOS	C	C	A	C	C		A	A		A	A	
Approach Delay		16.5			20.9		5.2	5.2		6.0	6.0	
Approach LOS		B			C		A	A		A	A	
Queue Length 50th (m)	2.3	6.1	0.0	3.2	7.7		4.3	4.3		2.9	2.9	
Queue Length 95th (m)	7.2	14.1	5.5	8.9	16.9		14.8	14.8		10.7	10.7	
Internal Link Dist (m)		55.7			119.8		103.0	103.0		90.8	90.8	
Turn Bay Length (m)	52.0		20.0									
Base Capacity (vph)	485	737	606	524	727		1857	1857		1464	1464	
Starvation Cap Reductn	0	0	0	0	0		0	0		0	0	
Spillback Cap Reductn	0	0	0	0	0		0	0		0	0	
Storage Cap Reductn	0	0	0	0	0		0	0		0	0	
Reduced v/c Ratio	0.05	0.09	0.07	0.06	0.12		0.15	0.15		0.12	0.12	

Intersection Summary												
Cycle Length:	75											
Actuated Cycle Length:	62.1											
Natural Cycle:	70											
Control Type:	Actuated-Uncoordinated											
Maximum v/c Ratio:	0.24											

Lanes, Volumes, Timings
1: Place d'Orleans & Centrum

AM Peak Hour
2028 Future Total

Intersection Signal Delay: 10.1	Intersection LOS: B
Intersection Capacity Utilization 60.3%	ICU Level of Service B
Analysis Period (min) 15	

Splits and Phases: 1: Place d'Orleans & Centrum



HCM 2010 TWSC
2: Centrum & Brisebois W

AM Peak Hour
2028 Future Total

Intersection												
Int Delay, s/veh	3.5											
Movement	EBL	EBT	EBR	WBL	WBT	WBR	NBL	NBT	NBR	SBL	SBT	SBR
Lane Configurations	↔			↔			↔			↔		
Traffic Vol, veh/h	70	81	10	2	126	4	0	0	1	2	0	78
Future Vol, veh/h	70	81	10	2	126	4	0	0	1	2	0	78
Conflicting Peds, #/hr	8	0	9	9	0	8	0	0	3	3	0	0
Sign Control	Free	Free	Free	Free	Free	Free	Stop	Stop	Stop	Stop	Stop	Stop
RT Channelized	-	-	None	-	-	None	-	-	None	-	-	None
Storage Length	-	-	-	-	-	-	-	-	-	-	-	-
Veh in Median Storage, #	-	0	-	-	0	-	-	0	-	-	0	-
Grade, %	-	0	-	-	0	-	-	0	-	-	0	-
Peak Hour Factor	100	100	100	100	100	100	100	100	100	100	100	100
Heavy Vehicles, %	2	5	2	2	3	2	2	2	100	2	2	2
Mvmt Flow	70	81	10	2	126	4	0	0	1	2	0	78

Major/Minor	Major1	Major2	Minor1	Minor2
Conflicting Flow All	138	0	0	100
Stage 1	-	-	-	-
Stage 2	-	-	-	-
Critical Hdwy	4.12	-	-	4.12
Critical Hdwy Stg 1	-	-	-	-
Critical Hdwy Stg 2	-	-	-	-
Follow-up Hdwy	2.218	-	-	2.218
Pot Cap-1 Maneuver	1446	-	-	1493
Stage 1	-	-	-	-
Stage 2	-	-	-	-
Platoon blocked, %	-	-	-	-
Mov Cap-1 Maneuver	1437	-	-	1483
Mov Cap-2 Maneuver	-	-	-	-
Stage 1	-	-	-	-
Stage 2	-	-	-	-

Approach	EB	WB	NB	SB
HCM Control Delay, s	3.3	0.1	9.9	9.4
HCM LOS			A	A

Minor Lane/Major Mvmt	NBLn1	EBL	EBT	EBR	WBL	WBT	WBR	SBLn1
Capacity (veh/h)	739	1437	-	-	1483	-	-	893
HCM Lane V/C Ratio	0.001	0.049	-	-	0.001	-	-	0.09
HCM Control Delay (s)	9.9	7.6	0	-	7.4	0	-	9.4
HCM Lane LOS	A	A	A	-	A	A	-	A
HCM 95th %tile Q(veh)	0	0.2	-	-	0	-	-	0.3

HCM 2010 AWSC
3: Prestone & Centrum

AM Peak Hour
2028 Future Total

Intersection	
Intersection Delay, s/veh	8
Intersection LOS	A

Movement	EBT	EBR	WBL	WBT	NBL	NBR
Lane Configurations	↔			↔	↔	↔
Traffic Vol, veh/h	20	42	101	18	56	81
Future Vol, veh/h	20	42	101	18	56	81
Peak Hour Factor	1.00	1.00	1.00	1.00	1.00	1.00
Heavy Vehicles, %	5	17	2	6	7	2
Mvmt Flow	20	42	101	18	56	81
Number of Lanes	1	0	0	1	1	1

Approach	EB	WB	NB
Opposing Approach	WB	EB	
Opposing Lanes	1	1	0
Conflicting Approach Left		NB	EB
Conflicting Lanes Left	0	2	1
Conflicting Approach Right	NB		WB
Conflicting Lanes Right	2	0	1
HCM Control Delay	7.4	8.3	8
HCM LOS	A	A	A

Lane	NBLn1	NBLn2	EBLn1	WBLn1
Vol Left, %	100%	0%	0%	85%
Vol Thru, %	0%	0%	32%	15%
Vol Right, %	0%	100%	68%	0%
Sign Control	Stop	Stop	Stop	Stop
Traffic Vol by Lane	56	81	62	119
LT Vol	56	0	0	101
Through Vol	0	0	20	18
RT Vol	0	81	42	0
Lane Flow Rate	56	81	62	119
Geometry Grp	7	7	2	2
Degree of Util (X)	0.086	0.096	0.07	0.149
Departure Headway (Hd)	5.544	4.254	4.04	4.497
Convergence, Y/N	Yes	Yes	Yes	Yes
Cap	650	847	890	801
Service Time	3.244	1.954	2.051	2.507
HCM Lane V/C Ratio	0.086	0.096	0.07	0.149
HCM Control Delay	8.8	7.4	7.4	8.3
HCM Lane LOS	A	A	A	A
HCM 95th %tile Q	0.3	0.3	0.2	0.5

HCM 2010 TWSC
4: Centrum & Brisebois E

AM Peak Hour
2028 Future Total

Intersection						
Int Delay, s/veh	6					
Movement	EBL	EBT	WBT	WBR	SBL	SBR
Lane Configurations		↕	↕		↕	↕
Traffic Vol, veh/h	56	19	26	1	0	67
Future Vol, veh/h	56	19	26	1	0	67
Conflicting Peds, #/hr	0	0	0	0	0	0
Sign Control	Free	Free	Free	Free	Stop	Stop
RT Channelized	-	None	-	None	-	None
Storage Length	-	-	-	-	0	-
Veh in Median Storage, #	-	0	0	-	0	-
Grade, %	-	0	0	-	0	-
Peak Hour Factor	100	100	100	100	100	100
Heavy Vehicles, %	9	2	2	2	2	20
Mvmt Flow	56	19	26	1	0	67
Major/Minor	Major1	Major2	Minor2			
Conflicting Flow All	27	0	0	158	27	
Stage 1	-	-	-	27	-	
Stage 2	-	-	-	131	-	
Critical Hdwy	4.19	-	-	6.42	6.4	
Critical Hdwy Stg 1	-	-	-	5.42	-	
Critical Hdwy Stg 2	-	-	-	5.42	-	
Follow-up Hdwy	2.281	-	-	3.518	3.48	
Pot Cap-1 Maneuver	1543	-	-	833	999	
Stage 1	-	-	-	996	-	
Stage 2	-	-	-	895	-	
Platoon blocked, %	-	-	-	-	-	
Mov Cap-1 Maneuver	1543	-	-	802	999	
Mov Cap-2 Maneuver	-	-	-	802	-	
Stage 1	-	-	-	959	-	
Stage 2	-	-	-	895	-	
Approach	EB	WB	SB			
HCM Control Delay, s	5.5	0	8.9			
HCM LOS	A					
Minor Lane/Major Mvmt	EBL	EBT	WBT	WBR	SBLn1	
Capacity (veh/h)	1543	-	-	-	999	
HCM Lane V/C Ratio	0.036	-	-	-	0.067	
HCM Control Delay (s)	7.4	0	-	-	8.9	
HCM Lane LOS	A	A	-	-	A	
HCM 95th %tile Q(veh)	0.1	-	-	-	0.2	

Lanes, Volumes, Timings
5: Prestone & St Joseph

AM Peak Hour
2028 Future Total



Lane Group	EBL	EBT	EBR	WBL	WBT	WBR	NBL	NBT	NBR	SBL	SBT	SBR
Lane Configurations	↕	↕	↕	↕	↕	↕	↕	↕	↕	↕	↕	↕
Traffic Volume (vph)	8	176	40	2	768	130	81	63	5	75	51	15
Future Volume (vph)	8	176	40	2	768	130	81	63	5	75	51	15
Satd. Flow (prot)	1658	3316	1375	1658	3316	1441	1626	1693	0	1566	1307	0
Fit Permitted	0.273			0.641			0.714			0.713		
Satd. Flow (perm)	476	3316	1375	1119	3316	1423	1221	1693	0	1173	1307	0
Satd. Flow (RTOR)			41			130		5			15	
Lane Group Flow (vph)	8	176	40	2	768	130	81	68	0	75	66	0
Turn Type	Perm	NA	Perm	Perm	NA	Perm	Perm	NA		Perm	NA	
Protected Phases		2			6			8			4	
Permitted Phases	2		2	6		6	8				4	
Detector Phase	2	2	2	6	6	6	8	8			4	4
Switch Phase												
Minimum Initial (s)	10.0	10.0	10.0	10.0	10.0	10.0	10.0	10.0		10.0	10.0	
Minimum Split (s)	23.7	23.7	23.7	23.7	23.7	23.7	29.0	29.0		29.0	29.0	
Total Split (s)	51.0	51.0	51.0	51.0	51.0	51.0	29.0	29.0		29.0	29.0	
Total Split (%)	63.8%	63.8%	63.8%	63.8%	63.8%	63.8%	36.3%	36.3%		36.3%	36.3%	
Yellow Time (s)	3.3	3.3	3.3	3.3	3.3	3.3	3.3	3.3		3.3	3.3	
All-Red Time (s)	2.4	2.4	2.4	2.4	2.4	2.4	2.7	2.7		2.7	2.7	
Lost Time Adjust (s)	0.0	0.0	0.0	0.0	0.0	0.0	0.0	0.0		0.0	0.0	
Total Lost Time (s)	5.7	5.7	5.7	5.7	5.7	5.7	6.0	6.0		6.0	6.0	
Lead/Lag												
Lead-Lag Optimize?												
Recall Mode	None	None	None	None	None	None	Max	Max		Max	Max	
Act Effct Green (s)	18.1	18.1	18.1	18.1	18.1	18.1	23.1	23.1		23.1	23.1	
Actuated g/C Ratio	0.34	0.34	0.34	0.34	0.34	0.34	0.44	0.44		0.44	0.44	
v/c Ratio	0.05	0.16	0.08	0.01	0.68	0.23	0.15	0.09		0.15	0.11	
Control Delay	11.8	12.0	4.6	10.5	18.1	3.8	11.5	10.1		11.5	9.3	
Queue Delay	0.0	0.0	0.0	0.0	0.0	0.0	0.0	0.0		0.0	0.0	
Total Delay	11.8	12.0	4.6	10.5	18.1	3.8	11.5	10.1		11.5	9.3	
LOS	B	B	A	B	B	A	B	B		B	A	
Approach Delay		10.7			16.0			10.9			10.5	
Approach LOS		B			B			B			B	
Queue Length 50th (m)	0.5	5.9	0.0	0.1	31.8	0.0	4.3	3.2		4.0	2.6	
Queue Length 95th (m)	2.7	10.9	4.3	1.1	46.4	7.8	13.2	10.7		12.5	9.9	
Internal Link Dist (m)		163.5			149.6			92.4			92.1	
Turn Bay Length (m)	50.0		105.0	62.5		120.0	47.5					
Base Capacity (vph)	409	2852	1188	962	2852	1242	533	742		512	579	
Starvation Cap Reductn	0	0	0	0	0	0	0	0		0	0	
Spillback Cap Reductn	0	0	0	0	0	0	0	0		0	0	
Storage Cap Reductn	0	0	0	0	0	0	0	0		0	0	
Reduced v/c Ratio	0.02	0.06	0.03	0.00	0.27	0.10	0.15	0.09		0.15	0.11	

Intersection Summary	
Cycle Length:	80
Actuated Cycle Length:	53
Natural Cycle:	55
Control Type:	Actuated-Uncoordinated
Maximum v/c Ratio:	0.68

Lanes, Volumes, Timings
5: Prestone & St Joseph

AM Peak Hour
2028 Future Total

Intersection Signal Delay: 14.1 Intersection LOS: B
Intersection Capacity Utilization 51.3% ICU Level of Service A
Analysis Period (min) 15

Splits and Phases: 5: Prestone & St Joseph



HCM 2010 TWSC
6: Access #1 & Brisebois

AM Peak Hour
2028 Future Total

Intersection						
Int Delay, s/veh	5.3					
Movement	EBT	EBR	WBL	WBT	NBL	NBR
Lane Configurations	↑			↑	↓	↓
Traffic Vol, veh/h	47	0	0	18	48	41
Future Vol, veh/h	47	0	0	18	48	41
Conflicting Peds, #/hr	0	0	0	0	0	0
Sign Control	Free	Free	Free	Free	Stop	Stop
RT Channelized	-	None	-	None	-	None
Storage Length	-	-	-	-	0	-
Veh in Median Storage, #	0	-	-	0	0	-
Grade, %	0	-	-	0	0	-
Peak Hour Factor	100	100	100	100	100	100
Heavy Vehicles, %	2	2	2	2	2	2
Mvmt Flow	47	0	0	18	48	41
Major/Minor	Major1	Major2	Minor1			
Conflicting Flow All	0	-	-	65	47	
Stage 1	-	-	-	47	-	
Stage 2	-	-	-	18	-	
Critical Hdwy	-	-	-	6.42	6.22	
Critical Hdwy Stg 1	-	-	-	5.42	-	
Critical Hdwy Stg 2	-	-	-	5.42	-	
Follow-up Hdwy	-	-	-	3.518	3.318	
Pot Cap-1 Maneuver	-	0	0	941	1022	
Stage 1	-	0	0	975	-	
Stage 2	-	0	0	1005	-	
Platoon blocked, %	-	-	-	-	-	
Mov Cap-1 Maneuver	-	-	-	941	1022	
Mov Cap-2 Maneuver	-	-	-	941	-	
Stage 1	-	-	-	975	-	
Stage 2	-	-	-	1005	-	
Approach	EB	WB	NB			
HCM Control Delay, s	0	0	9.1			
HCM LOS			A			
Minor Lane/Major Mvmt	NBLn1	EBT	WBT			
Capacity (veh/h)	977	-	-			
HCM Lane V/C Ratio	0.091	-	-			
HCM Control Delay (s)	9.1	-	-			
HCM Lane LOS	A	-	-			
HCM 95th %tile Q(veh)	0.3	-	-			

Lanes, Volumes, Timings
7: Access #2 & Brisebois

AM Peak Hour
2028 Future Total

Lane Group	EBT	EBR	WBL	WBT	NBL	NBR
Lane Configurations	↔		↔			
Traffic Volume (vph)	90	0	0	18	0	0
Future Volume (vph)	90	0	0	18	0	0
Satd. Flow (prot)	1745	0	0	1745	0	0
Fit Permitted						
Satd. Flow (perm)	1745	0	0	1745	0	0
Lane Group Flow (vph)	90	0	0	18	0	0
Sign Control	Free		Free		Free	
Intersection Summary						
Control Type: Unsignalized						
Intersection Capacity Utilization 8.3%						
ICU Level of Service A						
Analysis Period (min) 15						

HCM 2010 TWSC
8: Access #3 & Brisebois

AM Peak Hour
2028 Future Total

Intersection						
Int Delay, s/veh	4					
Movement	EBT	EBR	WBL	WBT	NBL	NBR
Lane Configurations	↔		↔			
Traffic Vol, veh/h	43	47	45	0	18	21
Future Vol, veh/h	43	47	45	0	18	21
Conflicting Peds, #/hr	0	0	0	0	0	0
Sign Control	Free	Free	Free	Free	Stop	Stop
RT Channelized	- None		- None		- None	
Storage Length	-		-		0 -	
Veh in Median Storage, #	0 -		-		0 -	
Grade, %	0 -		-		0 -	
Peak Hour Factor	100	100	100	100	100	100
Heavy Vehicles, %	2	2	2	2	2	2
Mvmt Flow	43	47	45	0	18	21
Major/Minor	Major1	Major2	Minor1			
Conflicting Flow All	0	0	90	0	157	67
Stage 1	-	-	-	-	67	-
Stage 2	-	-	-	-	90	-
Critical Hdwy	-	-	4.12	-	6.42	6.22
Critical Hdwy Stg 1	-	-	-	-	5.42	-
Critical Hdwy Stg 2	-	-	-	-	5.42	-
Follow-up Hdwy	-	-	2.218	-	3.518	3.318
Pot Cap-1 Maneuver	-	-	1505	-	834	997
Stage 1	-	-	-	-	956	-
Stage 2	-	-	-	-	934	-
Platoon blocked, %	-	-	-	-	-	-
Mov Cap-1 Maneuver	-	-	1505	-	809	997
Mov Cap-2 Maneuver	-	-	-	-	809	-
Stage 1	-	-	-	-	956	-
Stage 2	-	-	-	-	906	-
Approach	EB	WB	NB			
HCM Control Delay, s	0	7.5	9.2			
HCM LOS			A			
Minor Lane/Major Mvmt	NBLn1	EBT	EBR	WBL	WBT	
Capacity (veh/h)	900	-	-	1505	-	
HCM Lane V/C Ratio	0.043	-	-	0.03	-	
HCM Control Delay (s)	9.2	-	-	7.5	0	
HCM Lane LOS	A	-	-	A	A	
HCM 95th %tile Q(veh)	0.1	-	-	0.1	-	

Lanes, Volumes, Timings
1: Place d'Orleans & Centrum

PM Peak Hour
2028 Future Total

Lane Group	EBL	EBT	EBR	WBL	WBT	WBR	NBL	NBT	NBR	SBL	SBT	SBR
Lane Configurations	↔	↕	↔	↔	↕	↔		↕	↔	↔	↕	↔
Traffic Volume (vph)	94	108	220	54	94	4	102	151	80	112	143	42
Future Volume (vph)	94	108	220	54	94	4	102	151	80	112	143	42
Satd. Flow (prot)	1658	1745	1483	1658	1733	0	0	3087	0	0	3106	0
Fit Permitted	0.694			0.687				0.766			0.725	
Satd. Flow (perm)	1196	1745	1448	1186	1733	0	0	2398	0	0	2292	0
Satd. Flow (RTOR)			220		3			80			35	
Lane Group Flow (vph)	94	108	220	54	98	0	0	333	0	0	297	0
Turn Type	Perm	NA	Perm	Perm	NA		Perm	NA		Perm	NA	
Protected Phases		4		8			2		2		6	
Permitted Phases	4		4	8			2		2		6	
Detector Phase	4	4	4	8	8		2	2		6	6	
Switch Phase												
Minimum Initial (s)	10.0	10.0	10.0	10.0	10.0		10.0	10.0		10.0	10.0	
Minimum Split (s)	31.0	31.0	31.0	31.0	31.0		36.0	36.0		36.0	36.0	
Total Split (s)	32.0	32.0	32.0	32.0	32.0		53.0	53.0		53.0	53.0	
Total Split (%)	37.6%	37.6%	37.6%	37.6%	37.6%		62.4%	62.4%		62.4%	62.4%	
Yellow Time (s)	3.3	3.3	3.3	3.3	3.3		3.3	3.3		3.3	3.3	
All-Red Time (s)	2.7	2.7	2.7	2.7	2.7		2.7	2.7		2.7	2.7	
Lost Time Adjust (s)	0.0	0.0	0.0	0.0	0.0		0.0	0.0		0.0	0.0	
Total Lost Time (s)	6.0	6.0	6.0	6.0	6.0		6.0	6.0		6.0	6.0	
Lead/Lag												
Lead-Lag Optimize?												
Recall Mode	None	None	None	None	None		C-Max	C-Max		C-Max	C-Max	
Act Effct Green (s)	14.3	14.3	14.3	14.3	14.3		58.7	58.7		58.7	58.7	
Actuated g/C Ratio	0.17	0.17	0.17	0.17	0.17		0.69	0.69		0.69	0.69	
v/c Ratio	0.47	0.37	0.52	0.27	0.33		0.20	0.20		0.19	0.19	
Control Delay	38.1	33.3	8.5	32.0	31.5		4.6	4.6		5.3	5.3	
Queue Delay	0.0	0.0	0.0	0.0	0.0		0.0	0.0		0.0	0.0	
Total Delay	38.1	33.3	8.5	32.0	31.5		4.6	4.6		5.3	5.3	
LOS	D	C	A	C	C		A	A		A	A	
Approach Delay		21.4			31.7		4.6	4.6		5.3	5.3	
Approach LOS		C			C		A	A		A	A	
Queue Length 50th (m)	14.4	16.3	0.0	8.0	14.2		5.6	5.6		5.9	5.9	
Queue Length 95th (m)	23.9	25.3	15.1	15.2	23.1		16.3	16.3		16.6	16.6	
Internal Link Dist (m)		55.7			119.8		103.0	103.0		90.8	90.8	
Turn Bay Length (m)	52.0		20.0									
Base Capacity (vph)	365	533	595	362	532		1681	1681		1594	1594	
Starvation Cap Reductn	0	0	0	0	0		0	0		0	0	
Spillback Cap Reductn	0	0	0	0	0		0	0		0	0	
Storage Cap Reductn	0	0	0	0	0		0	0		0	0	
Reduced v/c Ratio	0.26	0.20	0.37	0.15	0.18		0.20	0.20		0.19	0.19	

Intersection Summary												
Cycle Length: 85												
Actuated Cycle Length: 85												
Offset: 0 (0%), Referenced to phase 2:NBTL and 6:SRTL, Start of Green												
Natural Cycle: 70												
Control Type: Actuated-Coordinated												

Lanes, Volumes, Timings
1: Place d'Orleans & Centrum

PM Peak Hour
2028 Future Total

Maximum v/c Ratio: 0.52	Intersection LOS: B
Intersection Signal Delay: 14.1	ICU Level of Service D
Intersection Capacity Utilization 80.0%	
Analysis Period (min) 15	

Splits and Phases: 1: Place d'Orleans & Centrum

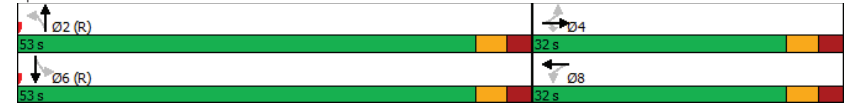

HCM 2010 TWSC
2: Centrum & Brisebois W

PM Peak Hour
2028 Future Total

Intersection												
Int Delay, s/veh	4											
Movement	EBL	EBT	EBR	WBL	WBT	WBR	NBL	NBT	NBR	SBL	SBT	SBR
Lane Configurations	↔			↔			↔			↔		
Traffic Vol, veh/h	93	179	8	1	118	11	7	0	8	15	0	102
Future Vol, veh/h	93	179	8	1	118	11	7	0	8	15	0	102
Conflicting Peds, #/hr	23	0	19	19	0	23	3	0	6	6	0	3
Sign Control	Free	Free	Free	Free	Free	Free	Stop	Stop	Stop	Stop	Stop	Stop
RT Channelized	-	-	None	-	-	None	-	-	None	-	-	None
Storage Length	-	-	-	-	-	-	-	-	-	-	-	-
Veh in Median Storage, #	-	0	-	-	0	-	-	0	-	-	0	-
Grade, %	-	0	-	-	0	-	-	0	-	-	0	-
Peak Hour Factor	100	100	100	100	100	100	100	100	100	100	100	100
Heavy Vehicles, %	2	3	2	2	5	2	2	2	2	2	2	2
Mvmt Flow	93	179	8	1	118	11	7	0	8	15	0	102

Major/Minor	Major1	Major2	Minor1	Minor2
Conflicting Flow All	152	0	0	206
Stage 1	-	-	-	-
Stage 2	-	-	-	-
Critical Hdwy	4.12	-	-	4.12
Critical Hdwy Stg 1	-	-	-	-
Critical Hdwy Stg 2	-	-	-	-
Follow-up Hdwy	2.218	-	-	2.218
Pot Cap-1 Maneuver	1429	-	-	1365
Stage 1	-	-	-	-
Stage 2	-	-	-	-
Platoon blocked, %	-	-	-	-
Mov Cap-1 Maneuver	1403	-	-	1345
Mov Cap-2 Maneuver	-	-	-	-
Stage 1	-	-	-	-
Stage 2	-	-	-	-

Approach	EB	WB	NB	SB
HCM Control Delay, s	2.6	0.1	12.3	10.5
HCM LOS			B	B

Minor Lane/Major Mvmt	NBLn1	EBL	EBT	EBR	WBL	WBT	WBR	SBLn1
Capacity (veh/h)	508	1403	-	-	1345	-	-	771
HCM Lane V/C Ratio	0.03	0.066	-	-	0.001	-	-	0.152
HCM Control Delay (s)	12.3	7.7	0	-	7.7	0	-	10.5
HCM Lane LOS	B	A	A	-	A	A	-	B
HCM 95th %tile Q(veh)	0.1	0.2	-	-	0	-	-	0.5

HCM 2010 AWSC
3: Prestone & Centrum

PM Peak Hour
2028 Future Total

Intersection	
Intersection Delay, s/veh	8.5
Intersection LOS	A

Movement	EBT	EBR	WBL	WBT	NBL	NBR
Lane Configurations	↔			↔	↔	↔
Traffic Vol, veh/h	39	116	116	18	80	103
Future Vol, veh/h	39	116	116	18	80	103
Peak Hour Factor	1.00	1.00	1.00	1.00	1.00	1.00
Heavy Vehicles, %	2	6	2	2	11	2
Mvmt Flow	39	116	116	18	80	103
Number of Lanes	1	0	0	1	1	1

Approach	EB	WB	NB
Opposing Approach	WB	EB	
Opposing Lanes	1	1	0
Conflicting Approach Left		NB	EB
Conflicting Lanes Left	0	2	1
Conflicting Approach Right	NB		WB
Conflicting Lanes Right	2	0	1
HCM Control Delay	8	8.8	8.6
HCM LOS	A	A	A

Lane	NBLn1	NBLn2	EBLn1	WBLn1
Vol Left, %	100%	0%	0%	87%
Vol Thru, %	0%	0%	25%	13%
Vol Right, %	0%	100%	75%	0%
Sign Control	Stop	Stop	Stop	Stop
Traffic Vol by Lane	80	103	155	134
LT Vol	80	0	0	116
Through Vol	0	0	39	18
RT Vol	0	103	116	0
Lane Flow Rate	80	103	155	134
Geometry Grp	7	7	2	2
Degree of Util (X)	0.13	0.128	0.176	0.176
Departure Headway (Hd)	5.833	4.472	4.098	4.722
Convergence, Y/N	Yes	Yes	Yes	Yes
Cap	615	801	877	761
Service Time	3.56	2.2	2.118	2.744
HCM Lane V/C Ratio	0.13	0.129	0.177	0.176
HCM Control Delay	9.4	7.9	8	8.8
HCM Lane LOS	A	A	A	A
HCM 95th-tile Q	0.4	0.4	0.6	0.6

HCM 2010 TWSC
4: Centrum & Brisebois E

PM Peak Hour
2028 Future Total

Intersection						
Int Delay, s/veh	5.2					
Movement	EBL	EBT	WBT	WBR	SBL	SBR
Lane Configurations		↖	↗		↙	↘
Traffic Vol, veh/h	74	49	39	0	0	79
Future Vol, veh/h	74	49	39	0	0	79
Conflicting Peds, #/hr	0	0	0	0	0	0
Sign Control	Free	Free	Free	Free	Stop	Stop
RT Channelized	-	None	-	None	-	None
Storage Length	-	-	-	-	0	-
Veh in Median Storage, #	-	0	0	-	0	-
Grade, %	-	0	0	-	0	-
Peak Hour Factor	100	100	100	100	100	100
Heavy Vehicles, %	2	2	2	2	2	2
Mvmt Flow	74	49	39	0	0	79
Major/Minor	Major1	Major2	Minor2			
Conflicting Flow All	39	0	0	236	39	
Stage 1	-	-	-	39	-	
Stage 2	-	-	-	197	-	
Critical Hdwy	4.12	-	-	6.42	6.22	
Critical Hdwy Stg 1	-	-	-	5.42	-	
Critical Hdwy Stg 2	-	-	-	5.42	-	
Follow-up Hdwy	2.218	-	-	3.518	3.318	
Pot Cap-1 Maneuver	1571	-	-	752	1033	
Stage 1	-	-	-	983	-	
Stage 2	-	-	-	836	-	
Platoon blocked, %	-	-	-	-	-	
Mov Cap-1 Maneuver	1571	-	-	716	1033	
Mov Cap-2 Maneuver	-	-	-	716	-	
Stage 1	-	-	-	936	-	
Stage 2	-	-	-	836	-	
Approach	EB	WB	SB			
HCM Control Delay, s	4.5	0	8.8			
HCM LOS			A			
Minor Lane/Major Mvmt	EBL	EBT	WBT	WBR	SBLn1	SBR
Capacity (veh/h)	1571	-	-	-	1033	
HCM Lane V/C Ratio	0.047	-	-	-	0.076	
HCM Control Delay (s)	7.4	0	-	-	8.8	
HCM Lane LOS	A	A	-	-	A	
HCM 95th %tile Q(veh)	0.1	-	-	-	0.2	

Lanes, Volumes, Timings
5: Prestone & St Joseph

PM Peak Hour
2028 Future Total

Lane Group	EBL	EBT	EBR	WBL	WBT	WBR	NBL	NBT	NBR	SBL	SBT	SBR
Lane Configurations	↖	↖↗	↖	↖	↖↗	↖	↖	↖	↖	↖	↖	↖
Traffic Volume (vph)	34	853	116	10	471	147	57	54	9	172	99	31
Future Volume (vph)	34	853	116	10	471	147	57	54	9	172	99	31
Satd. Flow (prot)	1658	3316	1483	1658	3316	1483	1658	1585	0	1658	1570	0
Fit Permitted	0.482			0.308			0.674			0.716		
Satd. Flow (perm)	841	3316	1444	537	3316	1464	1170	1585	0	1248	1570	0
Satd. Flow (RTOR)			116			147		9			20	
Lane Group Flow (vph)	34	853	116	10	471	147	57	63	0	172	130	0
Turn Type	Perm	NA	Perm	Perm	NA	Perm	Perm	NA		Perm	NA	
Protected Phases		2			6		8		8		4	
Permitted Phases	2		2	6		6	8				4	
Detector Phase	2	2	2	6	6	6	8	8			4	4
Switch Phase												
Minimum Initial (s)	10.0	10.0	10.0	10.0	10.0	10.0	10.0	10.0		10.0	10.0	
Minimum Split (s)	23.7	23.7	23.7	23.7	23.7	23.7	29.0	29.0		29.0	29.0	
Total Split (s)	51.0	51.0	51.0	51.0	51.0	51.0	29.0	29.0		29.0	29.0	
Total Split (%)	63.8%	63.8%	63.8%	63.8%	63.8%	63.8%	36.3%	36.3%		36.3%	36.3%	
Yellow Time (s)	3.3	3.3	3.3	3.3	3.3	3.3	3.3	3.3		3.3	3.3	
All-Red Time (s)	2.4	2.4	2.4	2.4	2.4	2.4	2.7	2.7		2.7	2.7	
Lost Time Adjust (s)	0.0	0.0	0.0	0.0	0.0	0.0	0.0	0.0		0.0	0.0	
Total Lost Time (s)	5.7	5.7	5.7	5.7	5.7	5.7	6.0	6.0		6.0	6.0	
Lead/Lag												
Lead-Lag Optimize?												
Recall Mode	Max	Max	Max	Max	Max	Max	None	None		None	None	
Act Effct Green (s)	48.1	48.1	48.1	48.1	48.1	48.1	15.6	15.6		15.6	15.6	
Actuated g/C Ratio	0.64	0.64	0.64	0.64	0.64	0.64	0.21	0.21		0.21	0.21	
v/c Ratio	0.06	0.40	0.12	0.03	0.22	0.15	0.24	0.19		0.67	0.38	
Control Delay	7.1	8.1	2.0	7.2	6.8	1.8	25.5	21.3		39.5	23.6	
Queue Delay	0.0	0.0	0.0	0.0	0.0	0.0	0.0	0.0		0.0	0.0	
Total Delay	7.1	8.1	2.0	7.2	6.8	1.8	25.5	21.3		39.5	23.6	
LOS	A	A	A	A	A	A	C	C		D	C	
Approach Delay		7.4			5.7		23.3				32.7	
Approach LOS		A			A		C				C	
Queue Length 50th (m)	1.6	26.4	0.0	0.4	12.6	0.0	6.5	6.0		21.5	12.7	
Queue Length 95th (m)	6.0	49.5	6.2	2.7	25.2	6.9	15.2	14.9		39.8	26.2	
Internal Link Dist (m)		163.5			149.6		92.4				92.1	
Turn Bay Length (m)	50.0		105.0	62.5		120.0	47.5					
Base Capacity (vph)	536	2113	962	342	2113	986	358	491		382	494	
Starvation Cap Reductn	0	0	0	0	0	0	0	0		0	0	
Spillback Cap Reductn	0	0	0	0	0	0	0	0		0	0	
Storage Cap Reductn	0	0	0	0	0	0	0	0		0	0	
Reduced v/c Ratio	0.06	0.40	0.12	0.03	0.22	0.15	0.16	0.13		0.45	0.26	

Intersection Summary												
Cycle Length: 80												
Actuated Cycle Length: 75.4												
Natural Cycle: 55												
Control Type: Actuated-Uncoordinated												
Maximum v/c Ratio: 0.67												

Lanes, Volumes, Timings
5: Prestone & St Joseph

PM Peak Hour
2028 Future Total

Intersection Signal Delay: 11.5	Intersection LOS: B
Intersection Capacity Utilization 63.3%	ICU Level of Service B
Analysis Period (min) 15	

Splits and Phases: 5: Prestone & St Joseph

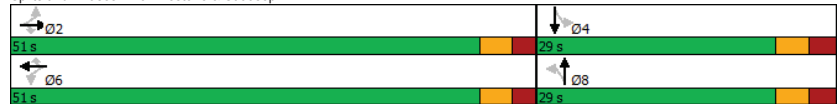

HCM 2010 TWSC
6: Access #1 & Brisebois

PM Peak Hour
2028 Future Total

Intersection						
Int Delay, s/veh	4.6					
Movement	EBT	EBR	WBL	WBT	NBL	NBR
Lane Configurations	↑				↑	↑
Traffic Vol, veh/h	78	0	0	18	55	40
Future Vol, veh/h	78	0	0	18	55	40
Conflicting Peds, #/hr	0	0	0	0	0	0
Sign Control	Free	Free	Free	Free	Stop	Stop
RT Channelized	-	None	-	None	-	None
Storage Length	-	-	-	-	0	-
Veh in Median Storage, #	0	-	-	0	0	-
Grade, %	0	-	-	0	0	-
Peak Hour Factor	100	100	100	100	100	100
Heavy Vehicles, %	2	2	2	2	2	2
Mvmt Flow	78	0	0	18	55	40
Major/Minor	Major1	Major2	Minor1			
Conflicting Flow All	0	-	-	-	96	78
Stage 1	-	-	-	-	78	-
Stage 2	-	-	-	-	18	-
Critical Hdwy	-	-	-	-	6.42	6.22
Critical Hdwy Stg 1	-	-	-	-	5.42	-
Critical Hdwy Stg 2	-	-	-	-	5.42	-
Follow-up Hdwy	-	-	-	-	3.518	3.318
Pot Cap-1 Maneuver	-	0	0	-	903	983
Stage 1	-	0	0	-	945	-
Stage 2	-	0	0	-	1005	-
Platoon blocked, %	-	-	-	-	-	-
Mov Cap-1 Maneuver	-	-	-	-	903	983
Mov Cap-2 Maneuver	-	-	-	-	903	-
Stage 1	-	-	-	-	945	-
Stage 2	-	-	-	-	1005	-
Approach	EB	WB	NB			
HCM Control Delay, s	0	0	9.3			
HCM LOS			A			
Minor Lane/Major Mvmt	NBLn1	EBT	WBT			
Capacity (veh/h)	935	-	-			
HCM Lane V/C Ratio	0.102	-	-			
HCM Control Delay (s)	9.3	-	-			
HCM Lane LOS	A	-	-			
HCM 95th %tile Q(veh)	0.3	-	-			

Lanes, Volumes, Timings
7: Access #2 & Brisebois

PM Peak Hour
2028 Future Total

Lane Group	EBT	EBR	WBL	WBT	NBL	NBR
Lane Configurations	↔		↔		↔	
Traffic Volume (vph)	122	0	0	18	0	0
Future Volume (vph)	122	0	0	18	0	0
Satd. Flow (prot)	1745	0	0	1745	0	0
Fit Permitted						
Satd. Flow (perm)	1745	0	0	1745	0	0
Lane Group Flow (vph)	122	0	0	18	0	0
Sign Control	Free		Free		Free	
Intersection Summary						
Control Type: Unsignalized						
Intersection Capacity Utilization 10.1%						
ICU Level of Service A						
Analysis Period (min) 15						

HCM 2010 TWSC
8: Access #3 & Brisebois

PM Peak Hour
2028 Future Total

Intersection						
Int Delay, s/veh	3.9					
Movement	EBT	EBR	WBL	WBT	NBL	NBR
Lane Configurations	↔		↔		↔	
Traffic Vol, veh/h	44	78	66	0	18	23
Future Vol, veh/h	44	78	66	0	18	23
Conflicting Peds, #/hr	0	0	0	0	0	0
Sign Control	Free	Free	Free	Free	Stop	Stop
RT Channelized	- None		- None		- None	
Storage Length	-		-		0	
Veh in Median Storage, #	0		-		0	
Grade, %	0		-		0	
Peak Hour Factor	100	100	100	100	100	100
Heavy Vehicles, %	2	2	2	2	2	2
Mvmt Flow	44	78	66	0	18	23
Major/Minor	Major1	Major2	Minor1			
Conflicting Flow All	0	0	122	0	215	83
Stage 1	-	-	-	-	83	-
Stage 2	-	-	-	-	132	-
Critical Hdwy	-	-	4.12	-	6.42	6.22
Critical Hdwy Stg 1	-	-	-	-	5.42	-
Critical Hdwy Stg 2	-	-	-	-	5.42	-
Follow-up Hdwy	-	-	2.218	-	3.518	3.318
Pot Cap-1 Maneuver	-	-	1465	-	773	976
Stage 1	-	-	-	-	940	-
Stage 2	-	-	-	-	894	-
Platoon blocked, %	-	-	-	-	-	-
Mov Cap-1 Maneuver	-	-	1465	-	738	976
Mov Cap-2 Maneuver	-	-	-	-	738	-
Stage 1	-	-	-	-	940	-
Stage 2	-	-	-	-	854	-
Approach	EB	WB	NB			
HCM Control Delay, s	0	7.6	9.4			
HCM LOS			A			
Minor Lane/Major Mvmt	NBLn1	EBT	EBR	WBL	WBT	
Capacity (veh/h)	855	-	-	1465	-	
HCM Lane V/C Ratio	0.048	-	-	0.045	-	
HCM Control Delay (s)	9.4	-	-	7.6	0	
HCM Lane LOS	A	-	-	A	A	
HCM 95th %tile Q(veh)	0.2	-	-	0.1	-	

Appendix J

Synchro Intersection Worksheets – 2033 Future Total Conditions

Lanes, Volumes, Timings
1: Place d'Orleans & Centrum

AM Peak Hour
2033 Future Total

Lane Group	EBL	EBT	EBR	WBL	WBT	WBR	NBL	NBT	NBR	SBL	SBT	SBR
Lane Configurations	↖	↗	↘	↖	↗	↘	↖	↗	↘	↖	↗	↘
Traffic Volume (vph)	25	66	40	34	82	4	67	175	62	112	42	19
Future Volume (vph)	25	66	40	34	82	4	67	175	62	112	42	19
Satd. Flow (prot)	1566	1745	1401	1658	1715	0	0	3142	0	0	3029	0
Fit Permitted	0.701			0.714				0.858			0.683	
Satd. Flow (perm)	1148	1745	1375	1239	1715	0	0	2725	0	0	2135	0
Satd. Flow (RTOR)			44		4			60			19	
Lane Group Flow (vph)	25	66	40	34	86	0	0	304	0	0	173	0
Turn Type	Perm	NA	Perm	Perm	NA	Perm	NA	Perm	NA	Perm	NA	
Protected Phases	4			8			2	2		6		6
Permitted Phases	4		4	8			2			6		6
Detector Phase	4	4	4	8	8		2	2		6	6	6
Switch Phase												
Minimum Initial (s)	10.0	10.0	10.0	10.0	10.0		10.0	10.0		10.0	10.0	
Minimum Split (s)	31.0	31.0	31.0	31.0	31.0		36.0	36.0		36.0	36.0	
Total Split (s)	32.0	32.0	32.0	32.0	32.0		43.0	43.0		43.0	43.0	
Total Split (%)	42.7%	42.7%	42.7%	42.7%	42.7%		57.3%	57.3%		57.3%	57.3%	
Yellow Time (s)	3.3	3.3	3.3	3.3	3.3		3.3	3.3		3.3	3.3	
All-Red Time (s)	2.7	2.7	2.7	2.7	2.7		2.7	2.7		2.7	2.7	
Lost Time Adjust (s)	0.0	0.0	0.0	0.0	0.0		0.0	0.0		0.0	0.0	
Total Lost Time (s)	6.0	6.0	6.0	6.0	6.0		6.0	6.0		6.0	6.0	
Lead/Lag												
Lead-Lag Optimize?												
Recall Mode	None	None	None	None	None		Max	Max		Max	Max	
Act Effct Green (s)	12.6	12.6	12.6	12.6	12.6		42.0	42.0		42.0	42.0	
Actuated g/C Ratio	0.20	0.20	0.20	0.20	0.20		0.68	0.68		0.68	0.68	
v/c Ratio	0.11	0.19	0.13	0.14	0.25		0.16	0.16		0.12	0.12	
Control Delay	20.2	21.0	7.0	20.6	21.0		5.3	5.3		6.0	6.0	
Queue Delay	0.0	0.0	0.0	0.0	0.0		0.0	0.0		0.0	0.0	
Total Delay	20.2	21.0	7.0	20.6	21.0		5.3	5.3		6.0	6.0	
LOS	C	C	A	C	C		A	A		A	A	
Approach Delay	16.6				20.9		5.3	5.3		6.0	6.0	
Approach LOS	B				C		A	A		A	A	
Queue Length 50th (m)	2.3	6.2	0.0	3.2	7.8		4.7	4.7		2.9	2.9	
Queue Length 95th (m)	7.2	14.1	5.5	8.9	17.0		15.8	15.8		10.7	10.7	
Internal Link Dist (m)		55.7			119.8		103.0	103.0		90.8	90.8	
Turn Bay Length (m)	52.0		20.0									
Base Capacity (vph)	485	737	606	524	727		1866	1866		1452	1452	
Starvation Cap Reductn	0	0	0	0	0		0	0		0	0	
Spillback Cap Reductn	0	0	0	0	0		0	0		0	0	
Storage Cap Reductn	0	0	0	0	0		0	0		0	0	
Reduced v/c Ratio	0.05	0.09	0.07	0.06	0.12		0.16	0.16		0.12	0.12	

Intersection Summary

Cycle Length: 75
Actuated Cycle Length: 62
Natural Cycle: 70
Control Type: Actuated-Uncoordinated
Maximum v/c Ratio: 0.25

Lanes, Volumes, Timings
1: Place d'Orleans & Centrum

AM Peak Hour
2033 Future Total

Intersection Signal Delay: 10.1
Intersection Capacity Utilization 60.8%
Analysis Period (min) 15

Intersection LOS: B
ICU Level of Service B

Splits and Phases: 1: Place d'Orleans & Centrum

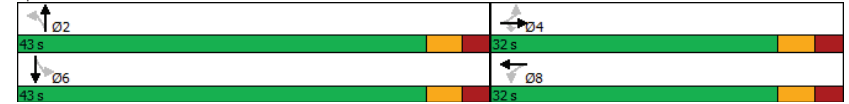

HCM 2010 TWSC
2: Centrum & Brisebois W

AM Peak Hour
2033 Future Total

Intersection												
Int Delay, s/veh 3.5												
Movement	EBL	EBT	EBR	WBL	WBT	WBR	NBL	NBT	NBR	SBL	SBT	SBR
Lane Configurations	↔			↔			↔			↔		
Traffic Vol, veh/h	70	82	10	2	127	4	0	0	1	2	0	78
Future Vol, veh/h	70	82	10	2	127	4	0	0	1	2	0	78
Conflicting Peds, #/hr	8	0	9	9	0	8	0	0	3	3	0	0
Sign Control	Free	Free	Free	Free	Free	Free	Stop	Stop	Stop	Stop	Stop	Stop
RT Channelized	-	-	None	-	-	None	-	-	None	-	-	None
Storage Length	-	-	-	-	-	-	-	-	-	-	-	-
Veh in Median Storage, #	-	0	-	-	0	-	-	0	-	-	0	-
Grade, %	-	0	-	-	0	-	-	0	-	-	0	-
Peak Hour Factor	100	100	100	100	100	100	100	100	100	100	100	100
Heavy Vehicles, %	2	5	2	2	3	2	2	2	100	2	2	2
Mvmt Flow	70	82	10	2	127	4	0	0	1	2	0	78

Major/Minor	Major1	Major2	Minor1	Minor2
Conflicting Flow All	139	0	0	101
Stage 1	-	-	-	-
Stage 2	-	-	-	-
Critical Hdwy	4.12	-	-	4.12
Critical Hdwy Stg 1	-	-	-	-
Critical Hdwy Stg 2	-	-	-	-
Follow-up Hdwy	2.218	-	-	2.218
Pot Cap-1 Maneuver	1445	-	-	1491
Stage 1	-	-	-	-
Stage 2	-	-	-	-
Platoon blocked, %	-	-	-	-
Mov Cap-1 Maneuver	1436	-	-	1481
Mov Cap-2 Maneuver	-	-	-	-
Stage 1	-	-	-	-
Stage 2	-	-	-	-

Approach	EB	WB	NB	SB
HCM Control Delay, s	3.3	0.1	9.9	9.4
HCM LOS			A	A

Minor Lane/Major Mvmt	NBLn1	EBL	EBT	EBR	WBL	WBT	WBR	SBLn1
Capacity (veh/h)	738	1436	-	-	1481	-	-	891
HCM Lane V/C Ratio	0.001	0.049	-	-	0.001	-	-	0.09
HCM Control Delay (s)	9.9	7.6	0	-	7.4	0	-	9.4
HCM Lane LOS	A	A	A	-	A	A	-	A
HCM 95th %tile Q(veh)	0	0.2	-	-	0	-	-	0.3

HCM 2010 AWSC
3: Prestone & Centrum

AM Peak Hour
2033 Future Total

Intersection	
Intersection Delay, s/veh	8
Intersection LOS	A

Movement	EBT	EBR	WBL	WBT	NBL	NBR
Lane Configurations	↔			↔	↔	↔
Traffic Vol, veh/h	21	42	101	18	56	81
Future Vol, veh/h	21	42	101	18	56	81
Peak Hour Factor	1.00	1.00	1.00	1.00	1.00	1.00
Heavy Vehicles, %	5	17	2	6	7	2
Mvmt Flow	21	42	101	18	56	81
Number of Lanes	1	0	0	1	1	1

Approach	EB	WB	NB
Opposing Approach	WB	EB	
Opposing Lanes	1	1	0
Conflicting Approach Left		NB	EB
Conflicting Lanes Left	0	2	1
Conflicting Approach Right	NB		WB
Conflicting Lanes Right	2	0	1
HCM Control Delay	7.4	8.3	8
HCM LOS	A	A	A

Lane	NBLn1	NBLn2	EBLn1	WBLn1
Vol Left, %	100%	0%	0%	85%
Vol Thru, %	0%	0%	33%	15%
Vol Right, %	0%	100%	67%	0%
Sign Control	Stop	Stop	Stop	Stop
Traffic Vol by Lane	56	81	63	119
LT Vol	56	0	0	101
Through Vol	0	0	21	18
RT Vol	0	81	42	0
Lane Flow Rate	56	81	63	119
Geometry Grp	7	7	2	2
Degree of Util (X)	0.086	0.096	0.071	0.149
Departure Headway (Hd)	5.546	4.256	4.047	4.498
Convergence, Y/N	Yes	Yes	Yes	Yes
Cap	650	847	888	801
Service Time	3.246	1.956	2.058	2.507
HCM Lane V/C Ratio	0.086	0.096	0.071	0.149
HCM Control Delay	8.8	7.4	7.4	8.3
HCM Lane LOS	A	A	A	A
HCM 95th %tile Q	0.3	0.3	0.2	0.5

HCM 2010 TWSC
4: Centrum & Brisebois E

AM Peak Hour
2033 Future Total

Intersection						
Int Delay, s/veh	5.9					
Movement	EBL	EBT	WBT	WBR	SBL	SBR
Lane Configurations		↕	↕		↕	↕
Traffic Vol, veh/h	56	19	27	1	0	67
Future Vol, veh/h	56	19	27	1	0	67
Conflicting Peds, #/hr	0	0	0	0	0	0
Sign Control	Free	Free	Free	Free	Stop	Stop
RT Channelized	-	None	-	None	-	None
Storage Length	-	-	-	-	0	-
Veh in Median Storage, #	-	0	0	-	0	-
Grade, %	-	0	0	-	0	-
Peak Hour Factor	100	100	100	100	100	100
Heavy Vehicles, %	9	2	2	2	2	20
Mvmt Flow	56	19	27	1	0	67
Major/Minor	Major1	Major2	Minor2			
Conflicting Flow All	28	0	0	159	28	
Stage 1	-	-	-	28	-	
Stage 2	-	-	-	131	-	
Critical Hdwy	4.19	-	-	6.42	6.4	
Critical Hdwy Stg 1	-	-	-	5.42	-	
Critical Hdwy Stg 2	-	-	-	5.42	-	
Follow-up Hdwy	2.281	-	-	3.518	3.48	
Pot Cap-1 Maneuver	1541	-	-	832	998	
Stage 1	-	-	-	995	-	
Stage 2	-	-	-	895	-	
Platoon blocked, %	-	-	-	-	-	
Mov Cap-1 Maneuver	1541	-	-	801	998	
Mov Cap-2 Maneuver	-	-	-	801	-	
Stage 1	-	-	-	958	-	
Stage 2	-	-	-	895	-	
Approach	EB	WB	SB			
HCM Control Delay, s	5.5	0	8.9			
HCM LOS	A					
Minor Lane/Major Mvmt	EBL	EBT	WBT	WBR	SBLn1	
Capacity (veh/h)	1541	-	-	-	998	
HCM Lane V/C Ratio	0.036	-	-	-	0.067	
HCM Control Delay (s)	7.4	0	-	-	8.9	
HCM Lane LOS	A	A	-	-	A	
HCM 95th %tile Q(veh)	0.1	-	-	-	0.2	

Lanes, Volumes, Timings
5: Prestone & St Joseph

AM Peak Hour
2033 Future Total

Lane Group	EBL	EBT	EBR	WBL	WBT	WBR	NBL	NBT	NBR	SBL	SBT	SBR
Lane Configurations	↕	↕↕	↕	↕	↕↕	↕	↕	↕	↕	↕	↕	↕
Traffic Volume (vph)	8	178	40	2	845	130	81	63	5	75	51	15
Future Volume (vph)	8	178	40	2	845	130	81	63	5	75	51	15
Satd. Flow (prot)	1658	3316	1375	1658	3316	1441	1626	1693	0	1566	1307	0
Fit Permitted	0.237			0.640			0.714			0.713		
Satd. Flow (perm)	414	3316	1375	1117	3316	1423	1221	1693	0	1173	1307	0
Satd. Flow (RTOR)			41			130		5			15	
Lane Group Flow (vph)	8	178	40	2	845	130	81	68	0	75	66	0
Turn Type	Perm	NA	Perm	Perm	NA	Perm	Perm	NA		Perm	NA	
Protected Phases		2			6			8			4	
Permitted Phases	2		2	6		6	8			4		
Detector Phase	2	2	2	6	6	6	8	8		4	4	
Switch Phase												
Minimum Initial (s)	10.0	10.0	10.0	10.0	10.0	10.0	10.0	10.0		10.0	10.0	
Minimum Split (s)	23.7	23.7	23.7	23.7	23.7	23.7	29.0	29.0		29.0	29.0	
Total Split (s)	51.0	51.0	51.0	51.0	51.0	51.0	29.0	29.0		29.0	29.0	
Total Split (%)	63.8%	63.8%	63.8%	63.8%	63.8%	63.8%	36.3%	36.3%		36.3%	36.3%	
Yellow Time (s)	3.3	3.3	3.3	3.3	3.3	3.3	3.3	3.3		3.3	3.3	
All-Red Time (s)	2.4	2.4	2.4	2.4	2.4	2.4	2.7	2.7		2.7	2.7	
Lost Time Adjust (s)	0.0	0.0	0.0	0.0	0.0	0.0	0.0	0.0		0.0	0.0	
Total Lost Time (s)	5.7	5.7	5.7	5.7	5.7	5.7	6.0	6.0		6.0	6.0	
Lead/Lag												
Lead-Lag Optimize?												
Recall Mode	None	None	None	None	None	None	Max	Max		Max	Max	
Act Effct Green (s)	19.8	19.8	19.8	19.8	19.8	19.8	23.1	23.1		23.1	23.1	
Actuated g/C Ratio	0.36	0.36	0.36	0.36	0.36	0.36	0.42	0.42		0.42	0.42	
v/c Ratio	0.05	0.15	0.08	0.00	0.70	0.22	0.16	0.09		0.15	0.12	
Control Delay	11.6	11.6	4.3	10.5	18.3	3.6	12.4	11.0		12.4	10.0	
Queue Delay	0.0	0.0	0.0	0.0	0.0	0.0	0.0	0.0		0.0	0.0	
Total Delay	11.6	11.6	4.3	10.5	18.3	3.6	12.4	11.0		12.4	10.0	
LOS	B	B	A	B	B	A	B	B		B	B	
Approach Delay		10.3			16.3			11.8			11.3	
Approach LOS		B			B			B			B	
Queue Length 50th (m)	0.5	6.0	0.0	0.1	36.2	0.0	4.8	3.6		4.4	2.9	
Queue Length 95th (m)	2.7	10.9	4.3	1.1	51.7	7.7	14.0	11.3		13.3	10.4	
Internal Link Dist (m)		163.5			149.6			92.4			92.1	
Turn Bay Length (m)	50.0		105.0	62.5		120.0	47.5					
Base Capacity (vph)	345	2763	1152	930	2763	1207	516	719		496	561	
Starvation Cap Reductn	0	0	0	0	0	0	0	0		0	0	
Spillback Cap Reductn	0	0	0	0	0	0	0	0		0	0	
Storage Cap Reductn	0	0	0	0	0	0	0	0		0	0	
Reduced v/c Ratio	0.02	0.06	0.03	0.00	0.31	0.11	0.16	0.09		0.15	0.12	
Intersection Summary												
Cycle Length: 80												
Actuated Cycle Length: 54.7												
Natural Cycle: 55												
Control Type: Actuated-Uncoordinated												
Maximum v/c Ratio: 0.70												

Lanes, Volumes, Timings
5: Prestone & St Joseph

AM Peak Hour
2033 Future Total

Intersection Signal Delay: 14.5	Intersection LOS: B
Intersection Capacity Utilization 53.6%	ICU Level of Service A
Analysis Period (min) 15	

Splits and Phases: 5: Prestone & St Joseph

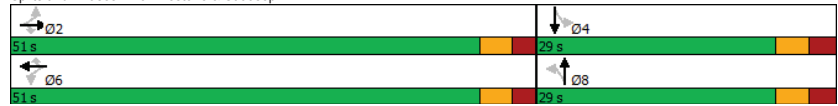

HCM 2010 TWSC
6: Access #1 & Brisebois

AM Peak Hour
2033 Future Total

Intersection						
Int Delay, s/veh	5.3					
Movement	EBT	EBR	WBL	WBT	NBL	NBR
Lane Configurations	↑			↑	↓	↓
Traffic Vol, veh/h	47	0	0	18	48	41
Future Vol, veh/h	47	0	0	18	48	41
Conflicting Peds, #/hr	0	0	0	0	0	0
Sign Control	Free	Free	Free	Free	Stop	Stop
RT Channelized	-	None	-	None	-	None
Storage Length	-	-	-	-	0	-
Veh in Median Storage, #	0	-	-	0	0	-
Grade, %	0	-	-	0	0	-
Peak Hour Factor	100	100	100	100	100	100
Heavy Vehicles, %	2	2	2	2	2	2
Mvmt Flow	47	0	0	18	48	41
Major/Minor	Major1	Major2	Minor1			
Conflicting Flow All	0	-	-	65	47	
Stage 1	-	-	-	47	-	
Stage 2	-	-	-	18	-	
Critical Hdwy	-	-	-	6.42	6.22	
Critical Hdwy Stg 1	-	-	-	5.42	-	
Critical Hdwy Stg 2	-	-	-	5.42	-	
Follow-up Hdwy	-	-	-	3.518	3.318	
Pot Cap-1 Maneuver	-	0	0	941	1022	
Stage 1	-	0	0	975	-	
Stage 2	-	0	0	1005	-	
Platoon blocked, %	-	-	-	-	-	
Mov Cap-1 Maneuver	-	-	-	941	1022	
Mov Cap-2 Maneuver	-	-	-	941	-	
Stage 1	-	-	-	975	-	
Stage 2	-	-	-	1005	-	
Approach	EB	WB	NB			
HCM Control Delay, s	0	0	9.1			
HCM LOS			A			
Minor Lane/Major Mvmt	NBLn1	EBT	WBT			
Capacity (veh/h)	977	-	-			
HCM Lane V/C Ratio	0.091	-	-			
HCM Control Delay (s)	9.1	-	-			
HCM Lane LOS	A	-	-			
HCM 95th %tile Q(veh)	0.3	-	-			

Lanes, Volumes, Timings
7: Access #2 & Brisebois

AM Peak Hour
2033 Future Total

Lane Group	EBT	EBR	WBL	WBT	NBL	NBR
Lane Configurations	↔		↔		↔	
Traffic Volume (vph)	90	0	0	18	0	0
Future Volume (vph)	90	0	0	18	0	0
Satd. Flow (prot)	1745	0	0	1745	0	0
Fit Permitted						
Satd. Flow (perm)	1745	0	0	1745	0	0
Lane Group Flow (vph)	90	0	0	18	0	0
Sign Control	Free		Free		Stop	
Intersection Summary						
Control Type: Unsignalized						
Intersection Capacity Utilization 8.3%						
ICU Level of Service A						
Analysis Period (min) 15						

HCM 2010 TWSC
8: Access #3 & Brisebois

AM Peak Hour
2033 Future Total

Intersection						
Int Delay, s/veh	4					
Movement	EBT	EBR	WBL	WBT	NBL	NBR
Lane Configurations	↔		↔		↔	
Traffic Vol, veh/h	43	47	45	0	18	21
Future Vol, veh/h	43	47	45	0	18	21
Conflicting Peds, #/hr	0	0	0	0	0	0
Sign Control	Free	Free	Free	Free	Stop	Stop
RT Channelized	- None		- None		- None	
Storage Length	-					
Veh in Median Storage, #	0					
Grade, %	0					
Peak Hour Factor	100	100	100	100	100	100
Heavy Vehicles, %	2	2	2	2	2	2
Mvmt Flow	43	47	45	0	18	21
Major/Minor	Major1	Major2	Minor1			
Conflicting Flow All	0	0	90	0	157	67
Stage 1	-	-	-	-	67	-
Stage 2	-	-	-	-	90	-
Critical Hdwy	-	-	4.12	-	6.42	6.22
Critical Hdwy Stg 1	-	-	-	-	5.42	-
Critical Hdwy Stg 2	-	-	-	-	5.42	-
Follow-up Hdwy	-	-	2.218	-	3.518	3.318
Pot Cap-1 Maneuver	-	-	1505	-	834	997
Stage 1	-	-	-	-	956	-
Stage 2	-	-	-	-	934	-
Platoon blocked, %	-					
Mov Cap-1 Maneuver	-	-	1505	-	809	997
Mov Cap-2 Maneuver	-	-	-	-	809	-
Stage 1	-	-	-	-	956	-
Stage 2	-	-	-	-	906	-
Approach	EB	WB	NB			
HCM Control Delay, s	0	7.5	9.2			
HCM LOS			A			
Minor Lane/Major Mvmt	NBLn1	EBT	EBR	WBL	WBT	
Capacity (veh/h)	900	-	-	1505	-	
HCM Lane V/C Ratio	0.043	-	-	0.03	-	
HCM Control Delay (s)	9.2	-	-	7.5	0	
HCM Lane LOS	A	-	-	A	A	
HCM 95th %tile Q(veh)	0.1	-	-	0.1	-	

Lanes, Volumes, Timings
1: Place d'Orleans & Centrum

PM Peak Hour
2033 Future Total

Lane Group	EBL	EBT	EBR	WBL	WBT	WBR	NBL	NBT	NBR	SBL	SBT	SBR
Lane Configurations	↔	↕	↔	↔	↕	↔	↔	↕	↔	↔	↕	↔
Traffic Volume (vph)	94	108	220	54	94	4	102	151	80	112	157	42
Future Volume (vph)	94	108	220	54	94	4	102	151	80	112	157	42
Satd. Flow (prot)	1658	1745	1483	1658	1733	0	0	3087	0	0	3112	0
Fit Permitted	0.694			0.687				0.761			0.730	
Satd. Flow (perm)	1196	1745	1448	1186	1733	0	0	2382	0	0	2309	0
Satd. Flow (RTOR)			220		3			80			33	
Lane Group Flow (vph)	94	108	220	54	98	0	0	333	0	0	311	0
Turn Type	Perm	NA	Perm	Perm	NA		Perm	NA		Perm	NA	
Protected Phases		4			8			2			6	
Permitted Phases	4		4	8			2			6		
Detector Phase	4	4	4	8	8		2	2		6	6	
Switch Phase												
Minimum Initial (s)	10.0	10.0	10.0	10.0	10.0		10.0	10.0		10.0	10.0	
Minimum Split (s)	31.0	31.0	31.0	31.0	31.0		36.0	36.0		36.0	36.0	
Total Split (s)	32.0	32.0	32.0	32.0	32.0		53.0	53.0		53.0	53.0	
Total Split (%)	37.6%	37.6%	37.6%	37.6%	37.6%		62.4%	62.4%		62.4%	62.4%	
Yellow Time (s)	3.3	3.3	3.3	3.3	3.3		3.3	3.3		3.3	3.3	
All-Red Time (s)	2.7	2.7	2.7	2.7	2.7		2.7	2.7		2.7	2.7	
Lost Time Adjust (s)	0.0	0.0	0.0	0.0	0.0		0.0	0.0		0.0	0.0	
Total Lost Time (s)	6.0	6.0	6.0	6.0	6.0		6.0	6.0		6.0	6.0	
Lead/Lag												
Lead-Lag Optimize?												
Recall Mode	None	None	None	None	None		C-Max	C-Max		C-Max	C-Max	
Act Effct Green (s)	14.3	14.3	14.3	14.3	14.3		58.7	58.7		58.7	58.7	
Actuated g/C Ratio	0.17	0.17	0.17	0.17	0.17		0.69	0.69		0.69	0.69	
v/c Ratio	0.47	0.37	0.52	0.27	0.33		0.20	0.20		0.19	0.19	
Control Delay	38.1	33.3	8.5	32.0	31.5		4.6	4.6		5.4	5.4	
Queue Delay	0.0	0.0	0.0	0.0	0.0		0.0	0.0		0.0	0.0	
Total Delay	38.1	33.3	8.5	32.0	31.5		4.6	4.6		5.4	5.4	
LOS	D	C	A	C	C		A	A		A	A	
Approach Delay		21.4			31.7		4.6	4.6		5.4	5.4	
Approach LOS		C			C		A	A		A	A	
Queue Length 50th (m)	14.4	16.3	0.0	8.0	14.2		5.6	5.6		6.3	6.3	
Queue Length 95th (m)	23.9	25.3	15.1	15.2	23.1		16.3	16.3		17.5	17.5	
Internal Link Dist (m)		55.7			119.8		103.0	103.0		90.8	90.8	
Turn Bay Length (m)	52.0		20.0									
Base Capacity (vph)	365	533	595	362	532		1670	1670		1605	1605	
Starvation Cap Reductn	0	0	0	0	0		0	0		0	0	
Spillback Cap Reductn	0	0	0	0	0		0	0		0	0	
Storage Cap Reductn	0	0	0	0	0		0	0		0	0	
Reduced v/c Ratio	0.26	0.20	0.37	0.15	0.18		0.20	0.20		0.19	0.19	

Intersection Summary												
Cycle Length: 85												
Actuated Cycle Length: 85												
Offset: 0 (0%), Referenced to phase 2:NBTL and 6:SBTL, Start of Green												
Natural Cycle: 70												
Control Type: Actuated-Coordinated												

Lanes, Volumes, Timings
1: Place d'Orleans & Centrum

PM Peak Hour
2033 Future Total

Maximum v/c Ratio: 0.52	Intersection LOS: B
Intersection Signal Delay: 14.0	ICU Level of Service D
Intersection Capacity Utilization 80.0%	
Analysis Period (min) 15	

Splits and Phases: 1: Place d'Orleans & Centrum

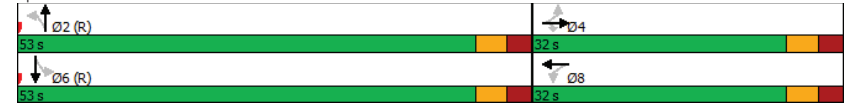

HCM 2010 TWSC
2: Centrum & Brisebois W

PM Peak Hour
2033 Future Total

Intersection												
Int Delay, s/veh	4											
Movement	EBL	EBT	EBR	WBL	WBT	WBR	NBL	NBT	NBR	SBL	SBT	SBR
Lane Configurations	↔			↔			↔			↔		
Traffic Vol, veh/h	93	181	8	1	120	11	7	0	8	15	0	102
Future Vol, veh/h	93	181	8	1	120	11	7	0	8	15	0	102
Conflicting Peds, #/hr	23	0	19	19	0	23	3	0	6	6	0	3
Sign Control	Free	Free	Free	Free	Free	Free	Stop	Stop	Stop	Stop	Stop	Stop
RT Channelized	-	-	None	-	-	None	-	-	None	-	-	None
Storage Length	-	-	-	-	-	-	-	-	-	-	-	-
Veh in Median Storage, #	-	0	-	-	0	-	-	0	-	-	0	-
Grade, %	-	0	-	-	0	-	-	0	-	-	0	-
Peak Hour Factor	100	100	100	100	100	100	100	100	100	100	100	100
Heavy Vehicles, %	2	3	2	2	5	2	2	2	2	2	2	2
Mvmt Flow	93	181	8	1	120	11	7	0	8	15	0	102

Major/Minor	Major1	Major2	Minor1	Minor2
Conflicting Flow All	154	0	0	208
Stage 1	-	-	-	-
Stage 2	-	-	-	-
Critical Hdwy	4.12	-	-	4.12
Critical Hdwy Stg 1	-	-	-	-
Critical Hdwy Stg 2	-	-	-	-
Follow-up Hdwy	2.218	-	-	2.218
Pot Cap-1 Maneuver	1426	-	-	1363
Stage 1	-	-	-	-
Stage 2	-	-	-	-
Platoon blocked, %	-	-	-	-
Mov Cap-1 Maneuver	1401	-	-	1343
Mov Cap-2 Maneuver	-	-	-	-
Stage 1	-	-	-	-
Stage 2	-	-	-	-

Approach	EB	WB	NB	SB
HCM Control Delay, s	2.6	0.1	12.3	10.5
HCM LOS			B	B

Minor Lane/Major Mvmt	NBLn1	EBL	EBT	EBR	WBL	WBT	WBR	SBLn1
Capacity (veh/h)	506	1401	-	-	1343	-	-	768
HCM Lane V/C Ratio	0.03	0.066	-	-	0.001	-	-	0.152
HCM Control Delay (s)	12.3	7.8	0	-	7.7	0	-	10.5
HCM Lane LOS	B	A	A	-	A	A	-	B
HCM 95th %tile Q(veh)	0.1	0.2	-	-	0	-	-	0.5

HCM 2010 AWSC
3: Prestone & Centrum

PM Peak Hour
2033 Future Total

Intersection	
Intersection Delay, s/veh	8.5
Intersection LOS	A

Movement	EBT	EBR	WBL	WBT	NBL	NBR
Lane Configurations	↔			↔	↔	↔
Traffic Vol, veh/h	40	116	116	18	80	103
Future Vol, veh/h	40	116	116	18	80	103
Peak Hour Factor	1.00	1.00	1.00	1.00	1.00	1.00
Heavy Vehicles, %	2	6	2	2	11	2
Mvmt Flow	40	116	116	18	80	103
Number of Lanes	1	0	0	1	1	1

Approach	EB	WB	NB
Opposing Approach	WB	EB	
Opposing Lanes	1	1	0
Conflicting Approach Left		NB	EB
Conflicting Lanes Left	0	2	1
Conflicting Approach Right	NB		WB
Conflicting Lanes Right	2	0	1
HCM Control Delay	8	8.8	8.6
HCM LOS	A	A	A

Lane	NBLn1	NBLn2	EBLn1	WBLn1
Vol Left, %	100%	0%	0%	87%
Vol Thru, %	0%	0%	26%	13%
Vol Right, %	0%	100%	74%	0%
Sign Control	Stop	Stop	Stop	Stop
Traffic Vol by Lane	80	103	156	134
LT Vol	80	0	0	116
Through Vol	0	0	40	18
RT Vol	0	103	116	0
Lane Flow Rate	80	103	156	134
Geometry Grp	7	7	2	2
Degree of Util (X)	0.13	0.128	0.178	0.176
Departure Headway (Hd)	5.834	4.474	4.101	4.723
Convergence, Y/N	Yes	Yes	Yes	Yes
Cap	615	801	875	761
Service Time	3.564	2.204	2.121	2.746
HCM Lane V/C Ratio	0.13	0.129	0.178	0.176
HCM Control Delay	9.4	7.9	8	8.8
HCM Lane LOS	A	A	A	A
HCM 95th-tile Q	0.4	0.4	0.6	0.6

HCM 2010 TWSC
4: Centrum & Brisebois E

PM Peak Hour
2033 Future Total

Intersection						
Int Delay, s/veh	5.2					
Movement	EBL	EBT	WBT	WBR	SBL	SBR
Lane Configurations		↖	↖		↗	↗
Traffic Vol, veh/h	74	49	40	0	0	79
Future Vol, veh/h	74	49	40	0	0	79
Conflicting Peds, #/hr	0	0	0	0	0	0
Sign Control	Free	Free	Free	Free	Stop	Stop
RT Channelized	-	None	-	None	-	None
Storage Length	-	-	-	-	0	-
Veh in Median Storage, #	-	0	0	-	0	-
Grade, %	-	0	0	-	0	-
Peak Hour Factor	100	100	100	100	100	100
Heavy Vehicles, %	2	2	2	2	2	2
Mvmt Flow	74	49	40	0	0	79
Major/Minor	Major1	Major2	Minor2			
Conflicting Flow All	40	0	-	0	237	40
Stage 1	-	-	-	-	40	-
Stage 2	-	-	-	-	197	-
Critical Hdwy	4.12	-	-	-	6.42	6.22
Critical Hdwy Stg 1	-	-	-	-	5.42	-
Critical Hdwy Stg 2	-	-	-	-	5.42	-
Follow-up Hdwy	2.218	-	-	-	3.518	3.318
Pot Cap-1 Maneuver	1570	-	-	-	751	1031
Stage 1	-	-	-	-	982	-
Stage 2	-	-	-	-	836	-
Platoon blocked, %	-	-	-	-	-	-
Mov Cap-1 Maneuver	1570	-	-	-	715	1031
Mov Cap-2 Maneuver	-	-	-	-	715	-
Stage 1	-	-	-	-	935	-
Stage 2	-	-	-	-	836	-
Approach	EB	WB	SB			
HCM Control Delay, s	4.5	0	8.8			
HCM LOS			A			
Minor Lane/Major Mvmt	EBL	EBT	WBT	WBR	SBLn1	
Capacity (veh/h)	1570	-	-	-	1031	
HCM Lane V/C Ratio	0.047	-	-	-	0.077	
HCM Control Delay (s)	7.4	0	-	-	8.8	
HCM Lane LOS	A	A	-	-	A	
HCM 95th %tile Q(veh)	0.1	-	-	-	0.2	

Lanes, Volumes, Timings
5: Prestone & St Joseph

PM Peak Hour
2033 Future Total



Lane Group	EBL	EBT	EBR	WBL	WBT	WBR	NBL	NBT	NBR	SBL	SBT	SBR
Lane Configurations	↖	↖↗	↖	↖	↖↗	↖	↖	↖	↖	↖	↖	↖
Traffic Volume (vph)	34	939	116	10	476	147	57	54	9	172	99	31
Future Volume (vph)	34	939	116	10	476	147	57	54	9	172	99	31
Satd. Flow (prot)	1658	3316	1483	1658	3316	1483	1658	1585	0	1658	1570	0
Fit Permitted	0.480			0.275			0.674			0.716		
Satd. Flow (perm)	837	3316	1444	479	3316	1464	1170	1585	0	1248	1570	0
Satd. Flow (RTOR)			116			147		9			20	
Lane Group Flow (vph)	34	939	116	10	476	147	57	63	0	172	130	0
Turn Type	Perm	NA	Perm	Perm	NA	Perm	Perm	NA		Perm	NA	
Protected Phases		2			6			8			4	
Permitted Phases	2		2	6		6	8				4	
Detector Phase	2	2	2	6	6	6	8	8			4	4
Switch Phase												
Minimum Initial (s)	10.0	10.0	10.0	10.0	10.0	10.0	10.0	10.0		10.0	10.0	
Minimum Split (s)	23.7	23.7	23.7	23.7	23.7	23.7	29.0	29.0		29.0	29.0	
Total Split (s)	51.0	51.0	51.0	51.0	51.0	51.0	29.0	29.0		29.0	29.0	
Total Split (%)	63.8%	63.8%	63.8%	63.8%	63.8%	63.8%	36.3%	36.3%		36.3%	36.3%	
Yellow Time (s)	3.3	3.3	3.3	3.3	3.3	3.3	3.3	3.3		3.3	3.3	
All-Red Time (s)	2.4	2.4	2.4	2.4	2.4	2.4	2.7	2.7		2.7	2.7	
Lost Time Adjust (s)	0.0	0.0	0.0	0.0	0.0	0.0	0.0	0.0		0.0	0.0	
Total Lost Time (s)	5.7	5.7	5.7	5.7	5.7	5.7	6.0	6.0		6.0	6.0	
Lead/Lag												
Lead-Lag Optimize?												
Recall Mode	Max	Max	Max	Max	Max	Max	None	None		None	None	
Act Effct Green (s)	48.1	48.1	48.1	48.1	48.1	48.1	15.6	15.6		15.6	15.6	
Actuated g/C Ratio	0.64	0.64	0.64	0.64	0.64	0.64	0.21	0.21		0.21	0.21	
v/c Ratio	0.06	0.44	0.12	0.03	0.23	0.15	0.24	0.19		0.67	0.38	
Control Delay	7.1	8.5	2.0	7.3	6.8	1.8	25.5	21.3		39.5	23.6	
Queue Delay	0.0	0.0	0.0	0.0	0.0	0.0	0.0	0.0		0.0	0.0	
Total Delay	7.1	8.5	2.0	7.3	6.8	1.8	25.5	21.3		39.5	23.6	
LOS	A	A	A	A	A	A	C	C		D	C	
Approach Delay		7.8			5.7		23.3				32.7	
Approach LOS		A			A		C				C	
Queue Length 50th (m)	1.6	30.2	0.0	0.4	12.7	0.0	6.5	6.0		21.5	12.7	
Queue Length 95th (m)	6.0	56.1	6.2	2.7	25.5	6.9	15.2	14.9		39.8	26.2	
Internal Link Dist (m)		163.5			149.6		92.4				92.1	
Turn Bay Length (m)	50.0		105.0	62.5		120.0	47.5					
Base Capacity (vph)	533	2113	962	305	2113	986	358	491		382	494	
Starvation Cap Reductn	0	0	0	0	0	0	0	0		0	0	
Spillback Cap Reductn	0	0	0	0	0	0	0	0		0	0	
Storage Cap Reductn	0	0	0	0	0	0	0	0		0	0	
Reduced v/c Ratio	0.06	0.44	0.12	0.03	0.23	0.15	0.16	0.13		0.45	0.26	

Intersection Summary												
Cycle Length: 80												
Actuated Cycle Length: 75.4												
Natural Cycle: 55												
Control Type: Actuated-Uncoordinated												
Maximum v/c Ratio: 0.67												

Lanes, Volumes, Timings
5: Prestone & St Joseph

PM Peak Hour
2033 Future Total

Intersection Signal Delay: 11.5	Intersection LOS: B
Intersection Capacity Utilization 63.3%	ICU Level of Service B
Analysis Period (min) 15	

Splits and Phases: 5: Prestone & St Joseph



HCM 2010 TWSC
6: Access #1 & Brisebois

PM Peak Hour
2033 Future Total

Intersection						
Int Delay, s/veh	4.6					
Movement	EBT	EBR	WBL	WBT	NBL	NBR
Lane Configurations	↑			↑	↑	↑
Traffic Vol, veh/h	78	0	0	18	55	40
Future Vol, veh/h	78	0	0	18	55	40
Conflicting Peds, #/hr	0	0	0	0	0	0
Sign Control	Free	Free	Free	Free	Stop	Stop
RT Channelized	-	None	-	None	-	None
Storage Length	-	-	-	-	0	-
Veh in Median Storage, #	0	-	-	0	0	-
Grade, %	0	-	-	0	0	-
Peak Hour Factor	100	100	100	100	100	100
Heavy Vehicles, %	2	2	2	2	2	2
Mvmt Flow	78	0	0	18	55	40
Major/Minor	Major1	Major2	Minor1			
Conflicting Flow All	0	-	-	-	96	78
Stage 1	-	-	-	-	78	-
Stage 2	-	-	-	-	18	-
Critical Hdwy	-	-	-	-	6.42	6.22
Critical Hdwy Stg 1	-	-	-	-	5.42	-
Critical Hdwy Stg 2	-	-	-	-	5.42	-
Follow-up Hdwy	-	-	-	-	3.518	3.318
Pot Cap-1 Maneuver	-	0	0	-	903	983
Stage 1	-	0	0	-	945	-
Stage 2	-	0	0	-	1005	-
Platoon blocked, %	-	-	-	-	-	-
Mov Cap-1 Maneuver	-	-	-	-	903	983
Mov Cap-2 Maneuver	-	-	-	-	903	-
Stage 1	-	-	-	-	945	-
Stage 2	-	-	-	-	1005	-
Approach	EB	WB	NB			
HCM Control Delay, s	0	0	9.3			
HCM LOS			A			
Minor Lane/Major Mvmt	NBLn1	EBT	WBT			
Capacity (veh/h)	935	-	-			
HCM Lane V/C Ratio	0.102	-	-			
HCM Control Delay (s)	9.3	-	-			
HCM Lane LOS	A	-	-			
HCM 95th %tile Q(veh)	0.3	-	-			

Lanes, Volumes, Timings
7: Access #2 & Brisebois

PM Peak Hour
2033 Future Total



Lane Group	EBT	EBR	WBL	WBT	NBL	NBR
Lane Configurations	↗			↖		
Traffic Volume (vph)	122	0	0	18	0	0
Future Volume (vph)	122	0	0	18	0	0
Satd. Flow (prot)	1745	0	0	1745	0	0
Fit Permitted						
Satd. Flow (perm)	1745	0	0	1745	0	0
Lane Group Flow (vph)	122	0	0	18	0	0
Sign Control	Free			Free	Free	

Intersection Summary	
Control Type:	Unsignalized
Intersection Capacity Utilization	10.1%
ICU Level of Service A	
Analysis Period (min)	15

HCM 2010 TWSC
8: Access #3 & Brisebois

PM Peak Hour
2033 Future Total

Intersection						
Int Delay, s/veh	3.9					
Movement	EBT	EBR	WBL	WBT	NBL	NBR
Lane Configurations	↗			↖	↖	↗
Traffic Vol, veh/h	44	78	66	0	18	23
Future Vol, veh/h	44	78	66	0	18	23
Conflicting Peds, #/hr	0	0	0	0	0	0
Sign Control	Free	Free	Free	Free	Stop	Stop
RT Channelized	-	None	-	None	-	None
Storage Length	-	-	-	-	0	-
Veh in Median Storage, #	0	-	-	0	0	-
Grade, %	0	-	-	0	0	-
Peak Hour Factor	100	100	100	100	100	100
Heavy Vehicles, %	2	2	2	2	2	2
Mvmt Flow	44	78	66	0	18	23

Major/Minor	Major1	Major2	Minor1
Conflicting Flow All	0	0	215
Stage 1	-	-	83
Stage 2	-	-	132
Critical Hdwy	-	4.12	6.42
Critical Hdwy Stg 1	-	-	5.42
Critical Hdwy Stg 2	-	-	5.42
Follow-up Hdwy	-	2.218	3.318
Pot Cap-1 Maneuver	-	1465	976
Stage 1	-	-	940
Stage 2	-	-	894
Platoon blocked, %	-	-	-
Mov Cap-1 Maneuver	-	1465	976
Mov Cap-2 Maneuver	-	-	738
Stage 1	-	-	940
Stage 2	-	-	854

Approach	EB	WB	NB
HCM Control Delay, s	0	7.6	9.4
HCM LOS			A

Minor Lane/Major Mvmt	NBLn1	EBT	EBR	WBL	WBT
Capacity (veh/h)	855	-	-	1465	-
HCM Lane V/C Ratio	0.048	-	-	0.045	-
HCM Control Delay (s)	9.4	-	-	7.6	0
HCM Lane LOS	A	-	-	A	A
HCM 95th %tile Q(veh)	0.2	-	-	0.1	-

Appendix K

MMLOS Analysis

Multi-Modal Level of Service - Intersections Form

Consultant Scenario Comments	CGH Transportation Inc.	Project Date	265 Centrum Boulevard
	Existing/Future		3/24/2023

INTERSECTIONS		Centrum Boulevard at Place d'Orleans Drive				St Joseph Boulevard at Prestone Drive			
Crossing Side		NORTH	SOUTH	EAST	WEST	NORTH	SOUTH	EAST	WEST
Pedestrian	Lanes	8	7	7	8	10+	10+	10+	10+
	Median	No Median - 2.4 m	No Median - 2.4 m	No Median - 2.4 m	No Median - 2.4 m	No Median - 2.4 m	No Median - 2.4 m	No Median - 2.4 m	No Median - 2.4 m
	Conflicting Left Turns	Permissive	Permissive	Permissive	Permissive	Permissive	Permissive	Permissive	Permissive
	Conflicting Right Turns	Permissive or yield control	Permissive or yield control	Permissive or yield control	Permissive or yield control	Permissive or yield control	Permissive or yield control	Permissive or yield control	Permissive or yield control
	Right Turns on Red (RTOR) ?	RTOR allowed	RTOR allowed	RTOR allowed	RTOR allowed	RTOR allowed	RTOR allowed	RTOR allowed	RTOR allowed
	Ped Signal Leading Interval?	No	No	No	No	No	No	No	No
	Right Turn Channel	Conv'tl without Receiving Lane	Conv'tl without Receiving Lane	No Channel	No Channel	Conventional with Receiving Lane	Conv'tl without Receiving Lane	Conv'tl without Receiving Lane	Conv'tl without Receiving Lane
	Corner Radius	5-10m	5-10m	10-15m	15-25m	15-25m	15-25m	15-25m	15-25m
	Crosswalk Type	Std transverse markings	Std transverse markings	Std transverse markings	Std transverse markings	Std transverse markings	Std transverse markings	Std transverse markings	Std transverse markings
	PETSI Score	-7	9	4	-14	-46	-43	-43	-43
	Ped. Exposure to Traffic LoS	F	F	F	F	#N/A	#N/A	#N/A	#N/A
	Cycle Length	75	75	85	85	80	80	80	80
	Effective Walk Time	29	29	11	11	7	7	34	34
	Average Pedestrian Delay	14	14	32	32	33	33	13	13
Pedestrian Delay LoS	B	B	D	D	D	D	B	B	
Level of Service	F	F	F	F	#N/A	#N/A	#N/A	#N/A	
Approach From		F				#N/A			
Approach From		NORTH	SOUTH	EAST	WEST	NORTH	SOUTH	EAST	WEST
Bicycle	Bicycle Lane Arrangement on Approach	Mixed Traffic	Mixed Traffic	Mixed Traffic	Mixed Traffic	Mixed Traffic	Mixed Traffic	Mixed Traffic	Mixed Traffic
	Right Turn Lane Configuration				≤ 50 m	≤ 50 m	≤ 50 m	> 50 m	> 50 m
	Right Turning Speed				≤ 25 km/h	>25 km/h	>25 km/h	>25 km/h	>25 km/h
	Cyclist relative to RT motorists	#N/A	#N/A	#N/A	D	E	E	F	F
	Separated or Mixed Traffic	Mixed Traffic	Mixed Traffic	Mixed Traffic	Mixed Traffic	Mixed Traffic	Mixed Traffic	Mixed Traffic	Mixed Traffic
	Left Turn Approach	One lane crossed	One lane crossed	One lane crossed	≥ 2 lanes crossed	One lane crossed	One lane crossed	≥ 2 lanes crossed	≥ 2 lanes crossed
	Operating Speed	≥ 60 km/h	≥ 60 km/h	> 40 to ≤ 50 km/h	> 40 to ≤ 50 km/h	> 40 to ≤ 50 km/h	> 40 to ≤ 50 km/h	≥ 60 km/h	> 50 to < 60 km/h
	Left Turning Cyclist	F	F	D	E	D	D	F	F
Level of Service	#N/A	#N/A	#N/A	E	E	E	F	F	
Level of Service		#N/A				F			
Transit	Average Signal Delay								
	Level of Service	-	-	-	-	-	-	-	-
Truck	Effective Corner Radius								
	Number of Receiving Lanes on Departure from Intersection								
Auto	Volume to Capacity Ratio								
	Level of Service			-				-	

Multi-Modal Level of Service - Segments Form

Consultant	CGH Transportation Inc.	Project	265 Centrum Boulevard
Scenario	Existing/Future	Date	3/24/2023
Comments			

SEGMENTS			Brisebois Crescent (Ex)	Centrum Boulevard	Brisebois Crescent (Fu)
			1	2	3
Pedestrian	Sidewalk Width	-	no sidewalk	≥ 2 m	≥ 2 m
	Boulevard Width		n/a	< 0.5	< 0.5
	Avg Daily Curb Lane Traffic Volume		≤ 3000	≤ 3000	≤ 3000
	Operating Speed		> 50 to 60 km/h	> 30 to 50 km/h	> 50 to 60 km/h
	On-Street Parking		yes	yes	yes
	Exposure to Traffic PLoS		F	B	C
	Effective Sidewalk Width				
Pedestrian Volume					
Crowding PLoS	-	-	-		
Level of Service	-	-	-		
Bicycle	Type of Cycling Facility	D	Mixed Traffic	Mixed Traffic	Mixed Traffic
	Number of Travel Lanes		≤ 2 (no centreline)	≤ 2 (no centreline)	≤ 2 (no centreline)
	Operating Speed		≥ 50 to 60 km/h	>40 to <50 km/h	≥ 50 to 60 km/h
	# of Lanes & Operating Speed LoS		D	B	D
	Bike Lane (+ Parking Lane) Width				
	Bike Lane Width LoS		-	-	-
	Bike Lane Blockages				
	Blockage LoS		-	-	-
	Median Refuge Width (no median = < 1.8 m)		< 1.8 m refuge	< 1.8 m refuge	< 1.8 m refuge
	No. of Lanes at Unsignalized Crossing		≤ 3 lanes	≤ 3 lanes	≤ 3 lanes
Sidestreet Operating Speed	>50 to 60 km/h	>40 to 50 km/h	>50 to 60 km/h		
Unsignalized Crossing - Lowest LoS	C	A	B		
Level of Service	D	B	D		
Transit	Facility Type	-			
	Friction or Ratio Transit:Posted Speed				
	Level of Service		-	-	-
Truck	Truck Lane Width	-			
	Travel Lanes per Direction				
	Level of Service		-	-	-

Appendix L

TDM Checklist

TDM Measures Checklist:
Non-Residential Developments (office, institutional, retail or industrial)

Legend	
BASIC	The measure is generally feasible and effective, and in most cases would benefit the development and its users
BETTER	The measure could maximize support for users of sustainable modes, and optimize development performance
★	The measure is one of the most dependably effective tools to encourage the use of sustainable modes

TDM measures: <i>Non-residential developments</i>		Check if proposed & add descriptions
1. TDM PROGRAM MANAGEMENT		
1.1 Program coordinator		
BASIC	★ 1.1.1 Designate an internal coordinator, or contract with an external coordinator	<input checked="" type="checkbox"/>
1.2 Travel surveys		
BETTER	1.2.1 Conduct periodic surveys to identify travel-related behaviours, attitudes, challenges and solutions, and to track progress	<input type="checkbox"/>
2. WALKING AND CYCLING		
2.1 Information on walking/cycling routes & destinations		
BASIC	2.1.1 Display local area maps with walking/cycling access routes and key destinations at major entrances	<input checked="" type="checkbox"/>
2.2 Bicycle skills training		
<i>Commuter travel</i>		
BETTER	★ 2.2.1 Offer on-site cycling courses for commuters, or subsidize off-site courses	<input type="checkbox"/>
2.3 Valet bike parking		
<i>Visitor travel</i>		
BETTER	2.3.1 Offer secure valet bike parking during public events when demand exceeds fixed supply (e.g. for festivals, concerts, games)	<input type="checkbox"/>

TDM measures: <i>Non-residential developments</i>		Check if proposed & add descriptions
3. TRANSIT		
3.1 Transit information		
BASIC	3.1.1 Display relevant transit schedules and route maps at entrances	<input checked="" type="checkbox"/>
BASIC	3.1.2 Provide online links to OC Transpo and STO information	<input checked="" type="checkbox"/>
BETTER	3.1.3 Provide real-time arrival information display at entrances	<input type="checkbox"/>
3.2 Transit fare incentives		
<i>Commuter travel</i>		
BETTER	3.2.1 Offer preloaded PRESTO cards to encourage commuters to use transit	<input type="checkbox"/>
BETTER	★ 3.2.2 Subsidize or reimburse monthly transit pass purchases by employees	<input type="checkbox"/>
<i>Visitor travel</i>		
BETTER	3.2.3 Arrange inclusion of same-day transit fare in price of tickets (e.g. for festivals, concerts, games)	<input type="checkbox"/>
3.3 Enhanced public transit service		
<i>Commuter travel</i>		
BETTER	3.3.1 Contract with OC Transpo to provide enhanced transit services (e.g. for shift changes, weekends)	<input type="checkbox"/>
<i>Visitor travel</i>		
BETTER	3.3.2 Contract with OC Transpo to provide enhanced transit services (e.g. for festivals, concerts, games)	<input type="checkbox"/>
3.4 Private transit service		
<i>Commuter travel</i>		
BETTER	3.4.1 Provide shuttle service when OC Transpo cannot offer sufficient quality or capacity to serve demand (e.g. for shift changes, weekends)	<input type="checkbox"/>
<i>Visitor travel</i>		
BETTER	3.4.2 Provide shuttle service when OC Transpo cannot offer sufficient quality or capacity to serve demand (e.g. for festivals, concerts, games)	<input type="checkbox"/>

TDM measures: <i>Non-residential developments</i>		Check if proposed & add descriptions
4. RIDESHARING		
4.1 Ridematching service		
<i>Commuter travel</i>		
BASIC ★	4.1.1 Provide a dedicated ridematching portal at OttawaRideMatch.com	<input checked="" type="checkbox"/>
4.2 Carpool parking price incentives		
<i>Commuter travel</i>		
BETTER	4.2.1 Provide discounts on parking costs for registered carpools	<input type="checkbox"/>
4.3 Vanpool service		
<i>Commuter travel</i>		
BETTER	4.3.1 Provide a vanpooling service for long-distance commuters	<input type="checkbox"/>
5. CARSHARING & BIKESHARING		
5.1 Bikeshare stations & memberships		
BETTER	5.1.1 Contract with provider to install on-site bikeshare station for use by commuters and visitors	<input type="checkbox"/>
<i>Commuter travel</i>		
BETTER	5.1.2 Provide employees with bikeshare memberships for local business travel	<input type="checkbox"/>
5.2 Carshare vehicles & memberships		
<i>Commuter travel</i>		
BETTER	5.2.1 Contract with provider to install on-site carshare vehicles and promote their use by tenants	<input type="checkbox"/>
BETTER	5.2.2 Provide employees with carshare memberships for local business travel	<input type="checkbox"/>
6. PARKING		
6.1 Priced parking		
<i>Commuter travel</i>		
BASIC ★	6.1.1 Charge for long-term parking (daily, weekly, monthly)	<input type="checkbox"/>
BASIC	6.1.2 Unbundle parking cost from lease rates at multi-tenant sites	<input checked="" type="checkbox"/>
<i>Visitor travel</i>		
BETTER	6.1.3 Charge for short-term parking (hourly)	<input type="checkbox"/>

TDM measures: <i>Non-residential developments</i>		Check if proposed & add descriptions
7. TDM MARKETING & COMMUNICATIONS		
7.1 Multimodal travel information		
<i>Commuter travel</i>		
BASIC ★	7.1.1 Provide a multimodal travel option information package to new/relocating employees and students	<input checked="" type="checkbox"/>
<i>Visitor travel</i>		
BETTER ★	7.1.2 Include multimodal travel option information in invitations or advertising that attract visitors or customers (e.g. for festivals, concerts, games)	<input type="checkbox"/>
7.2 Personalized trip planning		
<i>Commuter travel</i>		
BETTER ★	7.2.1 Offer personalized trip planning to new/relocating employees	<input checked="" type="checkbox"/>
7.3 Promotions		
<i>Commuter travel</i>		
BETTER	7.3.1 Deliver promotions and incentives to maintain awareness, build understanding, and encourage trial of sustainable modes	<input type="checkbox"/>
8. OTHER INCENTIVES & AMENITIES		
8.1 Emergency ride home		
<i>Commuter travel</i>		
BETTER ★	8.1.1 Provide emergency ride home service to non-driving commuters	<input type="checkbox"/>
8.2 Alternative work arrangements		
<i>Commuter travel</i>		
BASIC ★	8.2.1 Encourage flexible work hours	<input type="checkbox"/>
BETTER	8.2.2 Encourage compressed workweeks	<input checked="" type="checkbox"/>
BETTER ★	8.2.3 Encourage telework	<input type="checkbox"/>
8.3 Local business travel options		
<i>Commuter travel</i>		
BASIC ★	8.3.1 Provide local business travel options that minimize the need for employees to bring a personal car to work	<input type="checkbox"/>
8.4 Commuter incentives		
<i>Commuter travel</i>		
BETTER	8.4.1 Offer employees a taxable, mode-neutral commuting allowance	<input type="checkbox"/>
8.5 On-site amenities		
<i>Commuter travel</i>		
BETTER	8.5.1 Provide on-site amenities/services to minimize mid-day or mid-commute errands	<input type="checkbox"/>

TDM Measures Checklist:
Residential Developments (multi-family, condominium or subdivision)

Legend	
BASIC	The measure is generally feasible and effective, and in most cases would benefit the development and its users
BETTER	The measure could maximize support for users of sustainable modes, and optimize development performance
★	The measure is one of the most dependably effective tools to encourage the use of sustainable modes

TDM measures: Residential developments		Check if proposed & add descriptions
1. TDM PROGRAM MANAGEMENT		
1.1 Program coordinator		
BASIC ★	1.1.1 Designate an internal coordinator, or contract with an external coordinator	<input checked="" type="checkbox"/>
1.2 Travel surveys		
BETTER	1.2.1 Conduct periodic surveys to identify travel-related behaviours, attitudes, challenges and solutions, and to track progress	<input type="checkbox"/>
2. WALKING AND CYCLING		
2.1 Information on walking/cycling routes & destinations		
BASIC	2.1.1 Display local area maps with walking/cycling access routes and key destinations at major entrances (<i>multi-family, condominium</i>)	<input checked="" type="checkbox"/>
2.2 Bicycle skills training		
BETTER	2.2.1 Offer on-site cycling courses for residents, or subsidize off-site courses	<input type="checkbox"/>

TDM measures: Residential developments		Check if proposed & add descriptions
3. TRANSIT		
3.1 Transit information		
BASIC	3.1.1 Display relevant transit schedules and route maps at entrances (<i>multi-family, condominium</i>)	<input checked="" type="checkbox"/>
BETTER	3.1.2 Provide real-time arrival information display at entrances (<i>multi-family, condominium</i>)	<input type="checkbox"/>
3.2 Transit fare incentives		
BASIC ★	3.2.1 Offer PRESTO cards preloaded with one monthly transit pass on residence purchase/move-in, to encourage residents to use transit	<input type="checkbox"/>
BETTER	3.2.2 Offer at least one year of free monthly transit passes on residence purchase/move-in	<input type="checkbox"/>
3.3 Enhanced public transit service		
BETTER ★	3.3.1 Contract with OC Transpo to provide early transit services until regular services are warranted by occupancy levels (<i>subdivision</i>)	<input type="checkbox"/>
3.4 Private transit service		
BETTER	3.4.1 Provide shuttle service for seniors homes or lifestyle communities (e.g. scheduled mall or supermarket runs)	<input type="checkbox"/>
4. CARSHARING & BIKESHARING		
4.1 Bikeshare stations & memberships		
BETTER	4.1.1 Contract with provider to install on-site bikeshare station (<i>multi-family</i>)	<input type="checkbox"/>
BETTER	4.1.2 Provide residents with bikeshare memberships, either free or subsidized (<i>multi-family</i>)	<input type="checkbox"/>
4.2 Carshare vehicles & memberships		
BETTER	4.2.1 Contract with provider to install on-site carshare vehicles and promote their use by residents	<input type="checkbox"/>
BETTER	4.2.2 Provide residents with carshare memberships, either free or subsidized	<input type="checkbox"/>
5. PARKING		
5.1 Priced parking		
BASIC ★	5.1.1 Unbundle parking cost from purchase price (<i>condominium</i>)	<input checked="" type="checkbox"/>
BASIC ★	5.1.2 Unbundle parking cost from monthly rent (<i>multi-family</i>)	<input checked="" type="checkbox"/>

TDM measures: Residential developments		Check if proposed & add descriptions
6. TDM MARKETING & COMMUNICATIONS		
6.1 Multimodal travel information		
BASIC ★	6.1.1 Provide a multimodal travel option information package to new residents	<input checked="" type="checkbox"/>
6.2 Personalized trip planning		
BETTER ★	6.2.1 Offer personalized trip planning to new residents	<input type="checkbox"/>

TDM-Supportive Development Design and Infrastructure Checklist:
Non-Residential Developments (office, institutional, retail or industrial)

Legend	
REQUIRED	The Official Plan or Zoning By-law provides related guidance that must be followed
BASIC	The measure is generally feasible and effective, and in most cases would benefit the development and its users
BETTER	The measure could maximize support for users of sustainable modes, and optimize development performance

TDM-supportive design & infrastructure measures: Non-residential developments		Check if completed & add descriptions, explanations or plan/drawing references
1. WALKING & CYCLING: ROUTES		
1.1 Building location & access points		
BASIC	1.1.1 Locate building close to the street, and do not locate parking areas between the street and building entrances	<input checked="" type="checkbox"/>
BASIC	1.1.2 Locate building entrances in order to minimize walking distances to sidewalks and transit stops/stations	<input checked="" type="checkbox"/>
BASIC	1.1.3 Locate building doors and windows to ensure visibility of pedestrians from the building, for their security and comfort	<input checked="" type="checkbox"/>
1.2 Facilities for walking & cycling		
REQUIRED	1.2.1 Provide convenient, direct access to stations or major stops along rapid transit routes within 600 metres; minimize walking distances from buildings to rapid transit; provide pedestrian-friendly, weather-protected (where possible) environment between rapid transit accesses and building entrances; ensure quality linkages from sidewalks through building entrances to integrated stops/stations (see <i>Official Plan policy 4.3.3</i>)	<input checked="" type="checkbox"/>
REQUIRED	1.2.2 Provide safe, direct and attractive pedestrian access from public sidewalks to building entrances through such measures as: reducing distances between public sidewalks and major building entrances; providing walkways from public streets to major building entrances; within a site, providing walkways along the front of adjoining buildings, between adjacent buildings, and connecting areas where people may congregate, such as courtyards and transit stops; and providing weather protection through canopies, colonnades, and other design elements wherever possible (see <i>Official Plan policy 4.3.12</i>)	<input checked="" type="checkbox"/>

TDM-supportive design & infrastructure measures: <i>Non-residential developments</i>		Check if completed & add descriptions, explanations or plan/drawing references
REQUIRED	1.2.3 Provide sidewalks of smooth, well-drained walking surfaces of contrasting materials or treatments to differentiate pedestrian areas from vehicle areas, and provide marked pedestrian crosswalks at intersection sidewalks (see <i>Official Plan policy 4.3.10</i>)	<input checked="" type="checkbox"/>
REQUIRED	1.2.4 Make sidewalks and open space areas easily accessible through features such as gradual grade transition, depressed curbs at street corners and convenient access to extra-wide parking spaces and ramps (see <i>Official Plan policy 4.3.10</i>)	<input checked="" type="checkbox"/>
REQUIRED	1.2.5 Include adequately spaced inter-block/street cycling and pedestrian connections to facilitate travel by active transportation. Provide links to the existing or planned network of public sidewalks, multi-use pathways and on-road cycle routes. Where public sidewalks and multi-use pathways intersect with roads, consider providing traffic control devices to give priority to cyclists and pedestrians (see <i>Official Plan policy 4.3.11</i>)	<input checked="" type="checkbox"/>
BASIC	1.2.6 Provide safe, direct and attractive walking routes from building entrances to nearby transit stops	<input type="checkbox"/>
BASIC	1.2.7 Ensure that walking routes to transit stops are secure, visible, lighted, shaded and wind-protected wherever possible	<input type="checkbox"/>
BASIC	1.2.8 Design roads used for access or circulation by cyclists using a target operating speed of no more than 30 km/h, or provide a separated cycling facility	<input type="checkbox"/>
1.3 Amenities for walking & cycling		
BASIC	1.3.1 Provide lighting, landscaping and benches along walking and cycling routes between building entrances and streets, sidewalks and trails	<input type="checkbox"/>
BASIC	1.3.2 Provide wayfinding signage for site access (where required, e.g. when multiple buildings or entrances exist) and egress (where warranted, such as when directions to reach transit stops/stations, trails or other common destinations are not obvious)	<input type="checkbox"/>

TDM-supportive design & infrastructure measures: <i>Non-residential developments</i>		Check if completed & add descriptions, explanations or plan/drawing references
2. WALKING & CYCLING: END-OF-TRIP FACILITIES		
2.1 Bicycle parking		
REQUIRED	2.1.1 Provide bicycle parking in highly visible and lighted areas, sheltered from the weather wherever possible (see <i>Official Plan policy 4.3.6</i>)	<input checked="" type="checkbox"/>
REQUIRED	2.1.2 Provide the number of bicycle parking spaces specified for various land uses in different parts of Ottawa; provide convenient access to main entrances or well-used areas (see <i>Zoning By-law Section 111</i>)	<input checked="" type="checkbox"/>
REQUIRED	2.1.3 Ensure that bicycle parking spaces and access aisles meet minimum dimensions; that no more than 50% of spaces are vertical spaces; and that parking racks are securely anchored (see <i>Zoning By-law Section 111</i>)	<input checked="" type="checkbox"/>
BASIC	2.1.4 Provide bicycle parking spaces equivalent to the expected number of commuter cyclists (assuming the cycling mode share target is met), plus the expected peak number of customer/visitor cyclists	<input type="checkbox"/>
BETTER	2.1.5 Provide bicycle parking spaces equivalent to the expected number of commuter and customer/visitor cyclists, plus an additional buffer (e.g. 25 percent extra) to encourage other cyclists and ensure adequate capacity in peak cycling season	<input type="checkbox"/>
2.2 Secure bicycle parking		
REQUIRED	2.2.1 Where more than 50 bicycle parking spaces are provided for a single office building, locate at least 25% of spaces within a building/structure, a secure area (e.g. supervised parking lot or enclosure) or bicycle lockers (see <i>Zoning By-law Section 111</i>)	<input checked="" type="checkbox"/>
BETTER	2.2.2 Provide secure bicycle parking spaces equivalent to the expected number of commuter cyclists (assuming the cycling mode share target is met)	<input type="checkbox"/>
2.3 Shower & change facilities		
BASIC	2.3.1 Provide shower and change facilities for the use of active commuters	<input type="checkbox"/>
BETTER	2.3.2 In addition to shower and change facilities, provide dedicated lockers, grooming stations, drying racks and laundry facilities for the use of active commuters	<input type="checkbox"/>
2.4 Bicycle repair station		
BETTER	2.4.1 Provide a permanent bike repair station, with commonly used tools and an air pump, adjacent to the main bicycle parking area (or secure bicycle parking area, if provided)	<input type="checkbox"/>

TDM-supportive design & infrastructure measures: <i>Non-residential developments</i>		Check if completed & add descriptions, explanations or plan/drawing references
3. TRANSIT		
3.1 Customer amenities		
BASIC	3.1.1 Provide shelters, lighting and benches at any on-site transit stops	<input type="checkbox"/>
BASIC	3.1.2 Where the site abuts an off-site transit stop and insufficient space exists for a transit shelter in the public right-of-way, protect land for a shelter and/or install a shelter	<input type="checkbox"/>
BETTER	3.1.3 Provide a secure and comfortable interior waiting area by integrating any on-site transit stops into the building	<input type="checkbox"/>
4. RIDESHARING		
4.1 Pick-up & drop-off facilities		
BASIC	4.1.1 Provide a designated area for carpool drivers (plus taxis and ride-hailing services) to drop off or pick up passengers without using fire lanes or other no-stopping zones	<input type="checkbox"/>
4.2 Carpool parking		
BASIC	4.2.1 Provide signed parking spaces for carpools in a priority location close to a major building entrance, sufficient in number to accommodate the mode share target for carpools	<input type="checkbox"/>
BETTER	4.2.2 At large developments, provide spaces for carpools in a separate, access-controlled parking area to simplify enforcement	<input type="checkbox"/>
5. CARSHARING & BIKESHARING		
5.1 Carshare parking spaces		
BETTER	5.1.1 Provide carshare parking spaces in permitted non-residential zones, occupying either required or provided parking spaces (<i>see Zoning By-law Section 94</i>)	<input type="checkbox"/>
5.2 Bikeshare station location		
BETTER	5.2.1 Provide a designated bikeshare station area near a major building entrance, preferably lighted and sheltered with a direct walkway connection	<input type="checkbox"/>

TDM-supportive design & infrastructure measures: <i>Non-residential developments</i>		Check if completed & add descriptions, explanations or plan/drawing references
6. PARKING		
6.1 Number of parking spaces		
REQUIRED	6.1.1 Do not provide more parking than permitted by zoning, nor less than required by zoning, unless a variance is being applied for	<input checked="" type="checkbox"/>
BASIC	6.1.2 Provide parking for long-term and short-term users that is consistent with mode share targets, considering the potential for visitors to use off-site public parking	<input type="checkbox"/>
BASIC	6.1.3 Where a site features more than one use, provide shared parking and reduce the cumulative number of parking spaces accordingly (<i>see Zoning By-law Section 104</i>)	<input type="checkbox"/>
BETTER	6.1.4 Reduce the minimum number of parking spaces required by zoning by one space for each 13 square metres of gross floor area provided as shower rooms, change rooms, locker rooms and other facilities for cyclists in conjunction with bicycle parking (<i>see Zoning By-law Section 111</i>)	<input type="checkbox"/>
6.2 Separate long-term & short-term parking areas		
BETTER	6.2.1 Separate short-term and long-term parking areas using signage or physical barriers, to permit access controls and simplify enforcement (i.e. to discourage employees from parking in visitor spaces, and vice versa)	<input type="checkbox"/>
7. OTHER		
7.1 On-site amenities to minimize off-site trips		
BETTER	7.1.1 Provide on-site amenities to minimize mid-day or mid-commute errands	<input type="checkbox"/>

TDM-Supportive Development Design and Infrastructure Checklist:
Residential Developments (multi-family or condominium)

Legend	
REQUIRED	The Official Plan or Zoning By-law provides related guidance that must be followed
BASIC	The measure is generally feasible and effective, and in most cases would benefit the development and its users
BETTER	The measure could maximize support for users of sustainable modes, and optimize development performance

TDM-supportive design & infrastructure measures: <i>Residential developments</i>		Check if completed & add descriptions, explanations or plan/drawing references
1. WALKING & CYCLING: ROUTES		
1.1 Building location & access points		
BASIC	1.1.1 Locate building close to the street, and do not locate parking areas between the street and building entrances	<input checked="" type="checkbox"/>
BASIC	1.1.2 Locate building entrances in order to minimize walking distances to sidewalks and transit stops/stations	<input checked="" type="checkbox"/>
BASIC	1.1.3 Locate building doors and windows to ensure visibility of pedestrians from the building, for their security and comfort	<input checked="" type="checkbox"/>
1.2 Facilities for walking & cycling		
REQUIRED	1.2.1 Provide convenient, direct access to stations or major stops along rapid transit routes within 600 metres; minimize walking distances from buildings to rapid transit; provide pedestrian-friendly, weather-protected (where possible) environment between rapid transit accesses and building entrances; ensure quality linkages from sidewalks through building entrances to integrated stops/stations (see <i>Official Plan policy 4.3.3</i>)	<input checked="" type="checkbox"/>
REQUIRED	1.2.2 Provide safe, direct and attractive pedestrian access from public sidewalks to building entrances through such measures as: reducing distances between public sidewalks and major building entrances; providing walkways from public streets to major building entrances; within a site, providing walkways along the front of adjoining buildings, between adjacent buildings, and connecting areas where people may congregate, such as courtyards and transit stops; and providing weather protection through canopies, colonnades, and other design elements wherever possible (see <i>Official Plan policy 4.3.12</i>)	<input checked="" type="checkbox"/>

TDM-supportive design & infrastructure measures: <i>Residential developments</i>		Check if completed & add descriptions, explanations or plan/drawing references
REQUIRED	1.2.3 Provide sidewalks of smooth, well-drained walking surfaces of contrasting materials or treatments to differentiate pedestrian areas from vehicle areas, and provide marked pedestrian crosswalks at intersection sidewalks (see <i>Official Plan policy 4.3.10</i>)	<input checked="" type="checkbox"/>
REQUIRED	1.2.4 Make sidewalks and open space areas easily accessible through features such as gradual grade transition, depressed curbs at street corners and convenient access to extra-wide parking spaces and ramps (see <i>Official Plan policy 4.3.10</i>)	<input checked="" type="checkbox"/>
REQUIRED	1.2.5 Include adequately spaced inter-block/street cycling and pedestrian connections to facilitate travel by active transportation. Provide links to the existing or planned network of public sidewalks, multi-use pathways and on-road cycle routes. Where public sidewalks and multi-use pathways intersect with roads, consider providing traffic control devices to give priority to cyclists and pedestrians (see <i>Official Plan policy 4.3.11</i>)	<input checked="" type="checkbox"/>
BASIC	1.2.6 Provide safe, direct and attractive walking routes from building entrances to nearby transit stops	<input type="checkbox"/>
BASIC	1.2.7 Ensure that walking routes to transit stops are secure, visible, lighted, shaded and wind-protected wherever possible	<input type="checkbox"/>
BASIC	1.2.8 Design roads used for access or circulation by cyclists using a target operating speed of no more than 30 km/h, or provide a separated cycling facility	<input type="checkbox"/>
1.3 Amenities for walking & cycling		
BASIC	1.3.1 Provide lighting, landscaping and benches along walking and cycling routes between building entrances and streets, sidewalks and trails	<input type="checkbox"/>
BASIC	1.3.2 Provide wayfinding signage for site access (where required, e.g. when multiple buildings or entrances exist) and egress (where warranted, such as when directions to reach transit stops/stations, trails or other common destinations are not obvious)	<input type="checkbox"/>

TDM-supportive design & infrastructure measures: <i>Residential developments</i>		Check if completed & add descriptions, explanations or plan/drawing references
2. WALKING & CYCLING: END-OF-TRIP FACILITIES		
2.1 Bicycle parking		
REQUIRED	2.1.1 Provide bicycle parking in highly visible and lighted areas, sheltered from the weather wherever possible (see <i>Official Plan policy 4.3.6</i>)	<input checked="" type="checkbox"/>
REQUIRED	2.1.2 Provide the number of bicycle parking spaces specified for various land uses in different parts of Ottawa; provide convenient access to main entrances or well-used areas (see <i>Zoning By-law Section 111</i>)	<input checked="" type="checkbox"/>
REQUIRED	2.1.3 Ensure that bicycle parking spaces and access aisles meet minimum dimensions; that no more than 50% of spaces are vertical spaces; and that parking racks are securely anchored (see <i>Zoning By-law Section 111</i>)	<input checked="" type="checkbox"/>
BASIC	2.1.4 Provide bicycle parking spaces equivalent to the expected number of resident-owned bicycles, plus the expected peak number of visitor cyclists	<input type="checkbox"/>
2.2 Secure bicycle parking		
REQUIRED	2.2.1 Where more than 50 bicycle parking spaces are provided for a single residential building, locate at least 25% of spaces within a building/structure, a secure area (e.g. supervised parking lot or enclosure) or bicycle lockers (see <i>Zoning By-law Section 111</i>)	<input checked="" type="checkbox"/>
BETTER	2.2.2 Provide secure bicycle parking spaces equivalent to at least the number of units at condominiums or multi-family residential developments	<input type="checkbox"/>
2.3 Bicycle repair station		
BETTER	2.3.1 Provide a permanent bike repair station, with commonly used tools and an air pump, adjacent to the main bicycle parking area (or secure bicycle parking area, if provided)	<input type="checkbox"/>
3. TRANSIT		
3.1 Customer amenities		
BASIC	3.1.1 Provide shelters, lighting and benches at any on-site transit stops	<input type="checkbox"/>
BASIC	3.1.2 Where the site abuts an off-site transit stop and insufficient space exists for a transit shelter in the public right-of-way, protect land for a shelter and/or install a shelter	<input type="checkbox"/>
BETTER	3.1.3 Provide a secure and comfortable interior waiting area by integrating any on-site transit stops into the building	<input type="checkbox"/>

TDM-supportive design & infrastructure measures: <i>Residential developments</i>		Check if completed & add descriptions, explanations or plan/drawing references
4. RIDESHARING		
4.1 Pick-up & drop-off facilities		
BASIC	4.1.1 Provide a designated area for carpool drivers (plus taxis and ride-hailing services) to drop off or pick up passengers without using fire lanes or other no-stopping zones	<input type="checkbox"/>
5. CARSHARING & BIKESHARING		
5.1 Carshare parking spaces		
BETTER	5.1.1 Provide up to three carshare parking spaces in an R3, R4 or R5 Zone for specified residential uses (see <i>Zoning By-law Section 94</i>)	<input type="checkbox"/>
5.2 Bikeshare station location		
BETTER	5.2.1 Provide a designated bikeshare station area near a major building entrance, preferably lighted and sheltered with a direct walkway connection	<input type="checkbox"/>
6. PARKING		
6.1 Number of parking spaces		
REQUIRED	6.1.1 Do not provide more parking than permitted by zoning, nor less than required by zoning, unless a variance is being applied for	<input checked="" type="checkbox"/>
BASIC	6.1.2 Provide parking for long-term and short-term users that is consistent with mode share targets, considering the potential for visitors to use off-site public parking	<input type="checkbox"/>
BASIC	6.1.3 Where a site features more than one use, provide shared parking and reduce the cumulative number of parking spaces accordingly (see <i>Zoning By-law Section 104</i>)	<input type="checkbox"/>
BETTER	6.1.4 Reduce the minimum number of parking spaces required by zoning by one space for each 13 square metres of gross floor area provided as shower rooms, change rooms, locker rooms and other facilities for cyclists in conjunction with bicycle parking (see <i>Zoning By-law Section 111</i>)	<input type="checkbox"/>
6.2 Separate long-term & short-term parking areas		
BETTER	6.2.1 Provide separate areas for short-term and long-term parking (using signage or physical barriers) to permit access controls and simplify enforcement (i.e. to discourage residents from parking in visitor spaces, and vice versa)	<input type="checkbox"/>