

PEDESTRIAN LEVEL WIND STUDY

1345 Baseline Road
Ottawa, Ontario

Report: 22-147-PLW



May 26, 2022

PREPARED FOR
Scouts Canada
1345 Baseline Road
Ottawa, ON K2C 0A7

PREPARED BY
Daniel Davalos, MEng., Junior Wind Scientist
Justin Ferraro, P.Eng., Principal

EXECUTIVE SUMMARY

This report describes a pedestrian level wind (PLW) study undertaken to satisfy Zoning By-law Amendment application requirements for the proposed multi-building development located 1345 Baseline Road in Ottawa, Ontario (hereinafter referred to as “subject site” or “proposed development”). Our mandate within this study is to investigate pedestrian wind comfort and safety within and surrounding the subject site, and to identify areas where wind conditions may interfere with certain pedestrian activities so that mitigation measures may be considered, where required.

The study involves simulation of wind speeds for selected wind directions in a three-dimensional (3D) computer model using the computational fluid dynamics (CFD) technique, combined with meteorological data integration, to assess pedestrian wind comfort and safety within and surrounding the subject site according to City of Ottawa wind comfort and safety criteria. The results and recommendations derived from these considerations are detailed in the main body of the report (Section 5), illustrated in Figures 3A-7B, and summarized as follows:

- 1) All grade-level areas within and surrounding the subject site are predicted to experience conditions that are considered acceptable for the intended pedestrian uses throughout the year. Specifically, conditions over surrounding sidewalks, laneways, walkways, surface parking areas, and in the vicinity of building access points, are considered acceptable. A possible exception is described as follows:
 - a. **Park Southwest of Subject Site.** Conditions over the proposed future park situated at the southwest corner of the subject site are predicted to be suitable for a mix of sitting and standing during the typical use period, as illustrated in Figure 7A. Within the areas that are predicted to be suitable for standing, according to the comfort definition in Section 4.4, conditions are also predicted to be suitable for sitting for at least 70% of the time at the northeast corner, at least 65% of the time to the east, and at least 75% of the time throughout the remaining areas during the same period, where the target is 80% to achieve the sitting comfort class in Section 4.4.



- Depending on the programming of the space, the noted wind conditions may be considered acceptable. If required, sitting percentages may be increased around sensitive areas with landscaping features such as wind screens, high back seating, and/or coniferous plantings in dense arrangements. These features should be arranged to shield sensitive areas from prominent westerly winds.
- 2) The foregoing statements and conclusions apply to common weather systems, during which no dangerous wind conditions, as defined in Section 4.4, are expected anywhere over the subject site. During extreme weather events, (e.g., thunderstorms, tornadoes, and downbursts), pedestrian safety is the main concern. However, these events are generally short-lived and infrequent and there is often sufficient warning for pedestrians to take appropriate cover.

TABLE OF CONTENTS

1. INTRODUCTION 1

2. TERMS OF REFERENCE 1

3. OBJECTIVES 3

4. METHODOLOGY..... 3

4.1 Computer-Based Context Modelling4

4.2 Wind Speed Measurements.....4

4.3 Historical Wind Speed and Direction Data5

4.4 Pedestrian Comfort and Safety Criteria – City of Ottawa7

5. RESULTS AND DISCUSSION..... 9

5.1 Wind Comfort Conditions at Grade10

5.2 Wind Safety14

5.3 Applicability of Results15

6. CONCLUSIONS AND RECOMMENDATIONS 15

FIGURES

APPENDICES

Appendix A – Simulation of the Atmospheric Boundary Layer



1. INTRODUCTION

Gradient Wind Engineering Inc. (Gradient Wind) was retained by Scouts Canada to undertake a pedestrian level wind (PLW) study to satisfy Zoning By-law Amendment application requirements for the proposed multi-building development located at 1345 Baseline Road in Ottawa, Ontario (hereinafter referred to as “subject site” or “proposed development”). Our mandate within this study is to investigate pedestrian wind comfort and safety within and surrounding the subject site, and to identify areas where wind conditions may interfere with certain pedestrian activities so that mitigation measures may be considered, where required.

Our work is based on industry standard computer simulations using the computational fluid dynamics (CFD) technique and data analysis procedures, City of Ottawa wind comfort and safety criteria, preliminary architectural drawings prepared by Roderick Lahey Architect Inc., in May 2022, surrounding street layouts and existing and approved future building massing information obtained from the City of Ottawa, as well as recent satellite imagery.

2. TERMS OF REFERENCE

The subject site is located at 1345 Baseline Road in Ottawa; situated on the north side of Baseline Road approximately midblock between Merivale Road to the east and Clyde Avenue to the west. The proposed development comprises three buildings: a 28-storey “Building A” to the northwest, a 26-storey “Building B” to the northeast, and a 30-storey “Building C” situated to the south, closest to Baseline Road. All three buildings are served by four-storey podia and share two levels of below-grade parking. A roundabout is situated centrally to the subject site and a park is proposed at the southwest corner.

The ground floor of Building A includes bike storage to the north, a residential main entrance and move-in space to the south, and indoor amenities throughout the remainder of the floor. Levels 2-28 are reserved for residential use. A floorplate setback is situated to the southwest at Level 2. The building comprises a near rectangular planform above the podium.



The ground floor of Building B includes a residential main entrance and move-in space to the southwest, indoor amenity to the west, bike storage at the northwest corner, residential units to the east, and indoor amenities at the southeast corner. Access to below-grade parking is provided by a ramp to the north of Building B via a laneway from Baseline Road. Levels 2-26 are reserved for residential use. The building comprises a near rectangular planform above the podium.

The ground floor of Building C includes a residential main entrance, move-in space, and indoor amenities to the north, bike storage and building services at the northeast corner, and commercial space throughout the remainder of the floor. Access to below-grade parking is provided by a ramp to the northeast of Building C via a laneway from Baseline Road. This laneway divides the ground floor and

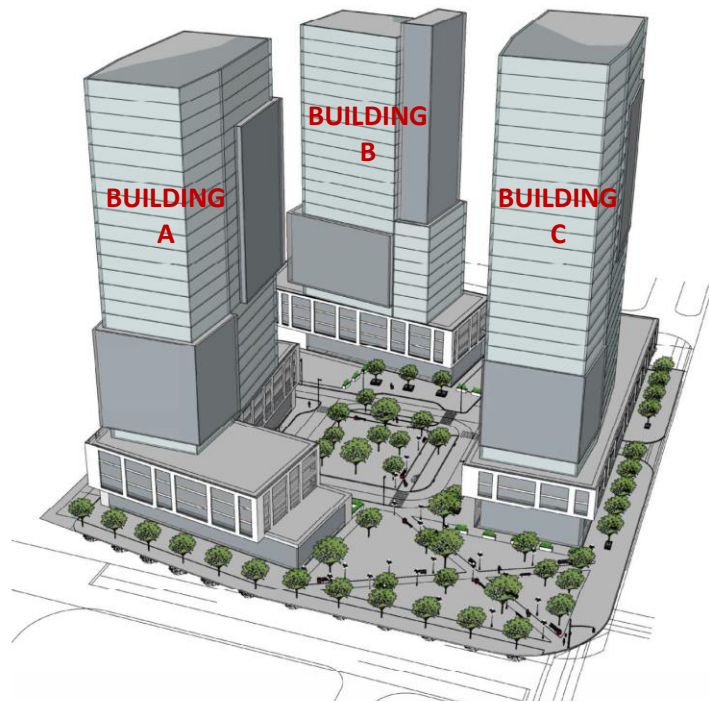

*Architectural Rendering of Proposed Development, Southwest Perspective
(Courtesy of Roderick Lahey Architect Inc.)*

Level 2 into two masses. Level 2 includes residential units to the northwest, commercial spaces to the northeast, while the southeast and southwest areas are open to the commercial spaces below. Levels 3-30 are reserved for residential use. The building comprises a near rectangular planform above the podium.

The shortest distance between the podia serving Building A and Building B is approximately 25.5 metres (m), while the shortest distance between the buildings above the podia, is approximately 32.4 m. The shortest distance between the podia serving Building B and Building C is approximately 7.8 m, while the shortest distance between the buildings above the podia, is approximately 29.9 m.

The near-field surroundings (defined as an area within 200 m of the subject site) include low-rise residential buildings to the northwest and north, a mid-rise commercial building to the northeast and east, and low-rise commercial buildings from the northeast clockwise west. The far-field surroundings (defined as an area beyond the near-field but within a 2-kilometre (km) radius of the subject site) are characterized by a mix of low-rise developments and green spaces with isolated mid- and high-rise buildings in all compass directions, and open fields to the northeast.

Site plans for the proposed and existing massing scenarios are illustrated in Figures 1A and 1B, while Figures 2A-2H illustrate the computational models used to conduct the study. The existing massing scenario includes the existing massing and any future developments approved by the City of Ottawa.

3. OBJECTIVES

The principal objectives of this study are to (i) determine pedestrian level wind comfort and safety conditions at key areas within and surrounding the development site; (ii) identify areas where wind conditions may interfere with the intended uses of outdoor spaces; and (iii) recommend suitable mitigation measures, where required.

4. METHODOLOGY

The approach followed to quantify pedestrian wind conditions over the site is based on CFD simulations of wind speeds across the study site within a virtual environment, meteorological analysis of the Ottawa area wind climate, and synthesis of computational data with City of Ottawa wind comfort and safety criteria¹. The following sections describe the analysis procedures, including a discussion of the noted pedestrian wind criteria.

¹ City of Ottawa Terms of References: Wind Analysis
https://documents.ottawa.ca/sites/default/files/torwindanalysis_en.pdf

4.1 Computer-Based Context Modelling

A computer based PLW study was performed to determine the influence of the wind environment on pedestrian comfort over the proposed development site. Pedestrian comfort predictions, based on the mechanical effects of wind, were determined by combining measured wind speed data from CFD simulations with statistical weather data obtained from Ottawa Macdonald-Cartier International Airport. The general concept and approach to CFD modelling is to represent building and topographic details in the immediate vicinity of the study site on the surrounding model, and to create suitable atmospheric wind profiles at the model boundary. The wind profiles are designed to have similar mean and turbulent wind properties consistent with actual site exposures.

An industry standard practice is to omit trees, vegetation, and other existing and planned landscape elements from the model due to the difficulty of providing accurate seasonal representation of vegetation. The omission of trees and other landscaping elements produces slightly stronger wind speeds.

4.2 Wind Speed Measurements

The PLW analysis was performed by simulating wind flows and gathering velocity data over a CFD model of the site for 12 wind directions. The CFD simulation model was centered on the study building, complete with surrounding massing within a radius of 480 m.

Mean and peak wind speed data obtained over the study site for each wind direction were interpolated to 36 wind directions at 10° intervals, representing the full compass azimuth. Measured wind speeds approximately 1.5 m above local grade were referenced to the wind speed at gradient height to generate mean and peak velocity ratios, which were used to calculate full-scale values. Gradient height represents the theoretical depth of the boundary layer of the earth's atmosphere, above which the mean wind speed remains constant. Further details of the wind flow simulation technique are presented in Appendix A.

4.3 Historical Wind Speed and Direction Data

A statistical model for winds in Ottawa was developed from approximately 40 years of hourly meteorological wind data recorded at Ottawa Macdonald-Cartier International Airport and obtained from Environment and Climate Change Canada. Wind speed and direction data were analyzed for each month of the year to determine the statistically prominent wind directions and corresponding speeds, and to characterize similarities between monthly weather patterns.

The statistical model of the Ottawa area wind climate, which indicates the directional character of local winds on a seasonal basis, is illustrated on the following page. The plots illustrate seasonal distribution of measured wind speeds and directions in kilometers per hour (km/h). Probabilities of occurrence of different wind speeds are represented as stacked polar bars in sixteen azimuth divisions. The radial direction represents the percentage of time for various wind speed ranges per wind direction during the measurement period. The preferred wind speeds and directions can be identified by the longer length of the bars. For Ottawa, the most common winds occur for westerly wind directions, followed by those from the east, while the most common wind speeds are below 36 km/h. The directional preference and relative magnitude of wind speed changes somewhat from season to season.

SEASONAL DISTRIBUTION OF WIND OTTAWA MACDONALD-CARTIER INTERNATIONAL AIRPORT

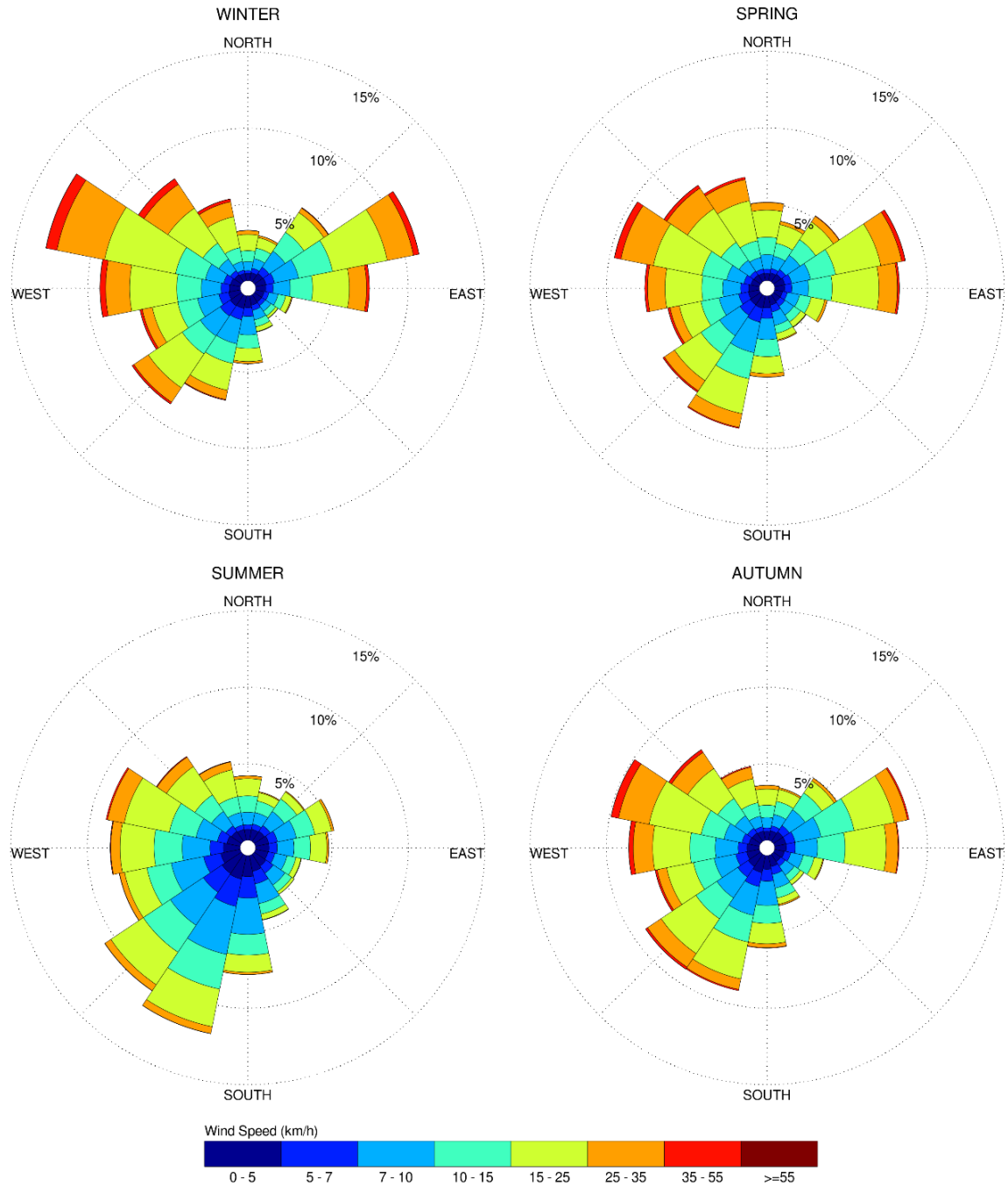

Notes:

1. Radial distances indicate percentage of time of wind events.
2. Wind speeds are mean hourly in km/h, measured at 10 m above the ground.

4.4 Pedestrian Comfort and Safety Criteria – City of Ottawa

Pedestrian comfort and safety criteria are based on the mechanical effects of wind without consideration of other meteorological conditions (i.e., temperature, relative humidity). The comfort criteria assume that pedestrians are appropriately dressed for a specified outdoor activity during any given season. Five pedestrian comfort classes are based on 20% non-exceedance mean wind speed ranges, which include (1) Sitting; (2) Standing; (3) Strolling; (4) Walking; and (5) Uncomfortable. More specifically, the comfort classes and associated mean wind speed ranges are summarized as follows:

- 1) **Sitting:** Mean wind speeds no greater than 10 km/h occurring at least 80% of the time. The equivalent gust wind speed is approximately 16 km/h.
- 2) **Standing:** Mean wind speeds no greater than 14 km/h occurring at least 80% of the time. The equivalent gust wind speed is approximately 22 km/h.
- 3) **Strolling:** Mean wind speeds no greater than 17 km/h occurring at least 80% of the time. The equivalent gust wind speed is approximately 27 km/h.
- 4) **Walking:** Mean wind speeds no greater than 20 km/h occurring at least 80% of the time. The equivalent gust wind speed is approximately 32 km/h.
- 5) **Uncomfortable:** Uncomfortable conditions are characterized by predicted values that fall below the 80% target for walking. Brisk walking and exercise, such as jogging, would be acceptable for moderate excesses of this criterion.

The pedestrian safety wind speed criterion is based on the approximate threshold that would cause a vulnerable member of the population to fall. A 0.1% exceedance gust wind speed of 90 km/h is classified as dangerous. The gust speeds, and equivalent mean speeds, are selected based on ‘The Beaufort Scale’, presented on the following page, which describes the effects of forces produced by varying wind speed levels on objects. Gust speeds are included because pedestrians tend to be more sensitive to wind gusts than to steady winds for lower wind speed ranges. For strong winds approaching dangerous levels, this effect is less important because the mean wind can also create problems for pedestrians.

THE BEAUFORT SCALE

Number	Description	Gust Wind Speed (km/h)	Description
2	Light Breeze	9-17	Wind felt on faces
3	Gentle Breeze	18-29	Leaves and small twigs in constant motion; wind extends light flags
4	Moderate Breeze	30-42	Wind raises dust and loose paper; small branches are moved
5	Fresh Breeze	43-57	Small trees in leaf begin to sway
6	Strong Breeze	58-74	Large branches in motion; Whistling heard in electrical wires; umbrellas used with difficulty
7	Moderate Gale	75-92	Whole trees in motion; inconvenient walking against wind
8	Gale	93-111	Breaks twigs off trees; generally impedes progress

Experience and research on people’s perception of mechanical wind effects has shown that if the wind speed levels are exceeded for more than 20% of the time, the activity level would be judged to be uncomfortable by most people. For instance, if a mean wind speed of 10 km/h (equivalent gust wind speed of approximately 16 km/h) were exceeded for more than 20% of the time most pedestrians would judge that location to be too windy for sitting. Similarly, if mean wind speed of 20 km/h (equivalent gust wind speed of approximately 32 km/h) at a location were exceeded for more than 20% of the time, walking or less vigorous activities would be considered uncomfortable. As these criteria are based on subjective reactions of a population to wind forces, their application is partly based on experience and judgment.

Once the pedestrian wind speed predictions have been established throughout the site, the assessment of pedestrian comfort involves determining the suitability of the predicted wind conditions for discrete regions within and surrounding the subject site. This step involves comparing the predicted comfort classes to the desired comfort classes, which are dictated by the location type for each region (i.e., a sidewalk, building entrance, amenity space, or other). An overview of common pedestrian location types and their typical windiest desired comfort classes are summarized on the following page. Depending on the programming of a space, the desired comfort class may differ from this table.

DESIRED PEDESTRIAN COMFORT CLASSES FOR VARIOUS LOCATION TYPES

Location Types	Desired Comfort Classes
Primary Building Entrance	Standing
Secondary Building Access Point	Walking
Public Sidewalk / Bicycle Path	Walking
Outdoor Amenity Space	Sitting
Café / Patio / Bench / Garden	Sitting (Typical Use Period)
Transit Stop (Without Shelter)	Standing
Transit Stop (With Shelter)	Walking
Public Park / Plaza	Sitting / Standing (Typical Use Period)
Garage / Service Entrance	Walking
Parking Lot	Walking
Vehicular Drop-Off Zone	Walking

5. RESULTS AND DISCUSSION

The following discussion of the predicted pedestrian wind conditions for the subject site is accompanied by Figures 3A-6B, illustrating wind conditions at grade level for the proposed and existing massing scenarios. Conditions are presented as continuous contours of wind comfort throughout the subject site and correspond to the comfort classes noted in Section 4.4. Wind conditions suitable for sitting are represented by the colour blue, standing by green, strolling by yellow, and walking by orange; uncomfortable conditions are represented by the colour magenta.

Wind conditions at grade are also reported for the typical use period, which is defined as May to October, inclusive. Figure 7A illustrates wind comfort conditions consistent with the comfort classes in Section 4.4, while Figure 7B illustrates contours indicating the percentage of time conditions are predicted to be suitable for sitting during the same period. The details of these conditions are summarized in the following pages for each area of interest.

5.1 Wind Comfort Conditions at Grade

Sidewalks and Building Access along Baseline Road: Following the introduction of the proposed development, the nearby public sidewalk areas along Baseline Road are predicted to be suitable for a mix of sitting and standing during the summer, suitable mostly for standing during the spring and autumn, becoming suitable for a mix of standing and strolling during the winter. Of importance, sidewalk areas adjacent to the south elevation of Building C are predicted to be suitable for sitting during the summer, becoming suitable for a mix of sitting and standing during the remaining three seasons. The noted conditions are considered acceptable according to the City of Ottawa wind comfort criteria.

Wind conditions over the sidewalks along Baseline Road with the existing massing are predicted to be suitable for sitting during the summer, suitable mostly for sitting during the autumn, becoming suitable for a mix of sitting and standing during the winter and spring. While the introduction of the proposed development produces windier conditions in comparison to existing conditions, wind comfort conditions with the proposed development are considered acceptable.

Park Southwest of Subject Site: Conditions over the park situated at the southwest corner of the subject site are predicted to be suitable mostly for sitting during the summer, becoming suitable mostly for standing during the remaining three seasons.

During the typical use period, conditions are predicted to be suitable for a mix of sitting and standing, as illustrated in Figure 7A. Within the areas that are predicted to be suitable for standing, according to the comfort definition in Section 4.4, conditions are also predicted to be suitable for sitting for at least 70% of the time at the northeast corner, at least 65% of the time to the east, and at least 75% of the time throughout the remaining areas during the same period, where the target is 80% to achieve the sitting comfort class in Section 4.4.

Depending on the programming of the space, the noted wind conditions may be considered acceptable. If required, sitting percentages may be increased around sensitive areas with landscaping features such as wind screens, high back seating, and/or coniferous plantings in dense arrangements. These features should be arranged to shield sensitive areas from prominent westerly winds.

Sidewalk along Laneway West of Subject Site: Following the introduction of the proposed development, the sidewalk area along the laneway situated to the immediate west of the subject site is predicted to be suitable mostly for sitting during the summer, becoming suitable mostly for standing during the remaining three seasons. The noted conditions are considered acceptable according to the City of Ottawa wind comfort criteria.

Wind conditions over the sidewalk along the noted laneway with the existing massing are predicted to be suitable for sitting during the spring, summer, and autumn, becoming suitable for a mix of sitting and standing during the winter. While the introduction of the proposed development produces windier conditions in comparison to existing conditions, wind comfort conditions with the proposed development are considered acceptable.

Walkway Along Laneway North of Subject Site: Conditions over the walkway along the north side of the subject site are predicted to be suitable for a mix of sitting and standing during the summer, becoming suitable for a mix of standing and strolling during the remaining three seasons with a region of walking adjacent to the northeast corner of Building B during the winter. The noted conditions are considered acceptable according to the City of Ottawa wind comfort criteria.

Surface Parking North of Subject Site: Following the introduction of the proposed development, the surface parking area to the north of the subject site is predicted to be suitable for a mix of sitting and standing during the summer, suitable mostly for standing during the autumn, becoming suitable for a mix of standing and strolling during the winter and spring. The noted conditions are considered acceptable according to the City of Ottawa wind comfort criteria.

Wind conditions over the surface parking area with the existing massing are predicted to be suitable for sitting during the summer and autumn, suitable mostly for sitting during the spring, becoming suitable for a mix of sitting and standing during the winter. While the introduction of the proposed development produces windier conditions in comparison to existing conditions, wind comfort conditions with the proposed development are considered acceptable.



Walkways and Building Access of Building A: Conditions over the walkway to the east of Building A are predicted to be suitable for sitting during the summer, becoming mostly suitable for standing during the remaining three seasons. Conditions over the walkways to the southeast of Building A are predicted to be suitable for sitting during the spring, summer, and autumn, becoming suitable for a mix of sitting and standing during the winter. Conditions over the walkway to the south of Building A are predicted to be suitable for sitting during the summer, becoming suitable for a mix of sitting and standing during the remaining three seasons. The noted conditions are considered acceptable according to the City of Ottawa wind comfort criteria.

Conditions in the vicinity of building access points serving Building A are predicted to be suitable for sitting during the summer and autumn, becoming suitable for standing during the winter and spring. The noted conditions are considered acceptable.

Walkways and Building Access West of Building B: Conditions over the walkways to the west of Building B are predicted to be suitable for a mix of sitting and standing during the summer, suitable mostly for standing during the autumn, suitable for a mix of standing and strolling during the spring, becoming suitable mostly for strolling during the winter. The noted conditions are considered acceptable according to the City of Ottawa wind comfort criteria.

Conditions in the vicinity of building access points along the west elevation of Building B are predicted to be suitable for sitting during the summer, becoming suitable for standing during the remaining three seasons. The noted conditions are considered acceptable.

Walkway and Building Access South of Building B: Conditions over the walkway to the south of Building B are predicted to be suitable for a mix of sitting and standing during the summer, suitable for a mix of standing and strolling during the spring and autumn, becoming suitable mostly for strolling with small and isolated regions that are predicted to be suitable for walking during the winter. The noted conditions are considered acceptable according to the City of Ottawa wind comfort criteria.

Conditions in the vicinity of the single building access point along the south elevation of Building B are predicted to be suitable for sitting during the summer, becoming suitable for standing during the remaining three seasons. The noted conditions are considered acceptable.

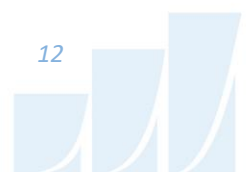

Surface Parking and Sidewalk along Laneway East of Subject Site: Following the introduction of the proposed development, the surface parking area situated to the east of the subject site is predicted to be suitable for a mix of sitting and standing during the summer, becoming suitable for a mix of standing and strolling during the spring and autumn, and suitable for a mix of standing, strolling, and walking during the winter. Conditions over the nearby public sidewalk along the laneway east of the subject site are predicted to be suitable for a mix of sitting and standing during the summer, becoming suitable for a mix of standing and strolling during the remaining three seasons. The noted conditions are considered acceptable according to the City of Ottawa wind comfort criteria.

Wind conditions over the noted surface parking area with the existing massing are predicted to be suitable for sitting during the summer, becoming suitable mostly for standing during the remaining three seasons. Conditions over the noted sidewalk are predicted to be suitable for sitting during the summer, becoming suitable for a mix of sitting and standing during the remaining three seasons. While the introduction of the proposed development produces windier conditions in comparison to existing conditions, wind comfort conditions with the proposed development are considered acceptable.

Walkway East of Building C: Conditions over the walkway situated to the immediate east of Building C are predicted to be suitable for sitting during the summer, becoming suitable for a mix of sitting and standing during the remaining three seasons. The noted conditions are considered acceptable according to the City of Ottawa wind comfort criteria.

Walkways and Building Access North of Building C: Conditions over the walkways to the north of Building C are predicted to be suitable mostly for sitting during the summer, becoming suitable for a mix of standing and strolling during the remaining three seasons. The noted conditions are considered acceptable according to the City of Ottawa wind comfort criteria.

Conditions in the vicinity of the primary building access point along the north elevation of Building C are predicted to be suitable for sitting during the summer, becoming suitable for a mix of sitting and standing during the remaining three seasons. Conditions in the vicinity of the secondary building access point along the north elevation are predicted to be suitable for sitting during the summer, becoming suitable for standing during the remaining three seasons. The noted conditions are considered acceptable according to the City of Ottawa wind comfort criteria.



Walkway and Building Access West of Building C: Conditions over the walkway to the west of Building C are predicted to be suitable for sitting during the summer, suitable for a mix of sitting and standing during the spring and autumn, becoming suitable for standing during the winter. The noted conditions are considered acceptable according to the City of Ottawa wind comfort criteria.

Conditions in the vicinity of potential building access points along the west elevation of Building C are predicted to be suitable for sitting during the spring, summer, and autumn, becoming suitable for standing during the winter. The noted conditions are considered acceptable according to the City of Ottawa wind comfort criteria.

Laneway Intersecting Building C: Conditions over the north-south laneway intersecting Building C are predicted to be suitable mostly for standing during the summer, suitable for a mix of standing and strolling during the autumn, becoming suitable mostly for strolling during the winter and spring. The noted conditions are considered acceptable for laneways and walkways according to the City of Ottawa wind comfort criteria. If building access points will front onto the laneway, we recommend that they be recessed into the building by at least 1.5 m.

Walkways Within Central Roundabout: Conditions over the walkways within the central roundabout are predicted to be suitable for standing during the summer, suitable for a mix of standing and strolling during the spring and autumn, becoming suitable for strolling during the winter. The noted conditions are considered acceptable according to the City of Ottawa wind comfort criteria.

5.2 Wind Safety

Within the context of typical weather patterns, which exclude anomalous localized storm events such as tornadoes and downbursts, no pedestrian areas within and surrounding the subject site were found to experience conditions that could be considered dangerous, as defined in Section 4.4.

5.3 Applicability of Results

Pedestrian wind comfort and safety have been quantified for the specific configuration of existing and foreseeable construction around the subject site. Future changes (i.e., construction or demolition) of these surroundings may cause changes to the wind effects in two ways, namely: (i) changes beyond the immediate vicinity of the subject site would alter the wind profile approaching the subject site; and (ii) development in proximity to the subject site would cause changes to local flow patterns.

Regarding primary and secondary building access points, wind conditions predicted in this study are only applicable to pedestrian comfort and safety. As such, the results should not be construed to indicate wind loading on doors and associated hardware.

6. CONCLUSIONS AND RECOMMENDATIONS

A complete summary of the predicted wind conditions is provided in Section 5 and illustrated in Figures 3A-7B. Based on computer simulations using the CFD technique, meteorological data analysis of the Ottawa wind climate, City of Ottawa wind comfort and safety criteria, and experience with numerous similar developments, the study concludes the following:

- 1) All grade-level areas within and surrounding the subject site are predicted to experience conditions that are considered acceptable for the intended pedestrian uses throughout the year. Specifically, conditions over surrounding sidewalks, laneways, walkways, surface parking areas, and in the vicinity of building access points, are considered acceptable. A possible exception is described as follows:
 - a. **Park Southwest of Subject Site.** Conditions over the proposed future park situated at the southwest corner of the subject site are predicted to be suitable for a mix of sitting and standing during the typical use period, as illustrated in Figure 7A. Within the areas that are predicted to be suitable for standing, according to the comfort definition in Section 4.4, conditions are also predicted to be suitable for sitting for at least 70% of the time at the northeast corner, at least 65% of the time to the east, and at least 75% of the time throughout the remaining areas during the same period, where the target is 80% to achieve the sitting comfort class in Section 4.4.



- Depending on the programming of the space, the noted wind conditions may be considered acceptable. If required, sitting percentages may be increased around sensitive areas with landscaping features such as wind screens, high back seating, and/or coniferous plantings in dense arrangements. These features should be arranged to shield sensitive areas from prominent westerly winds.
- 2) The foregoing statements and conclusions apply to common weather systems, during which no dangerous wind conditions, as defined in Section 4.4, are expected anywhere over the subject site. During extreme weather events, (e.g., thunderstorms, tornadoes, and downbursts), pedestrian safety is the main concern. However, these events are generally short-lived and infrequent and there is often sufficient warning for pedestrians to take appropriate cover.

Sincerely,

Gradient Wind Engineering Inc.



Daniel Davalos, MEng.
Junior Wind Scientist



Justin Ferraro, P.Eng.
Principal

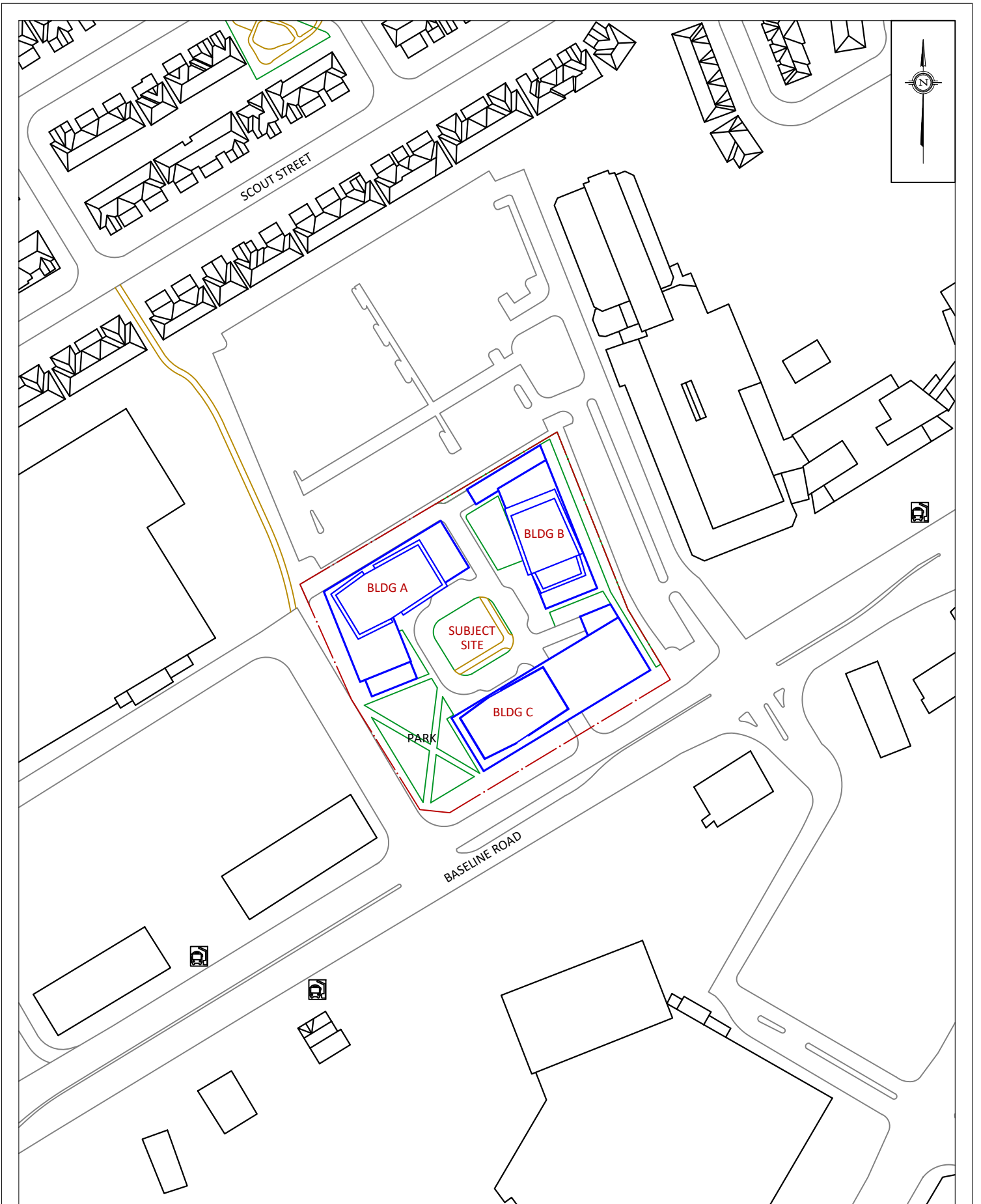

GRADIENTWIND

ENGINEERS & SCIENTISTS

127 WALGREEN ROAD, OTTAWA, ON
613 836 0934 • GRADIENTWIND.COM

PROJECT

1345 BASELINE ROAD, OTTAWA
PEDESTRIAN LEVEL WIND STUDY

SCALE

1:2000

DRAWING NO.

22-147-PLW-1A

DATE

MAY 26, 2022

DRAWN BY

S.K.

DESCRIPTION

FIGURE 1A:
PROPOSED SITE PLAN AND SURROUNDING CONTEXT

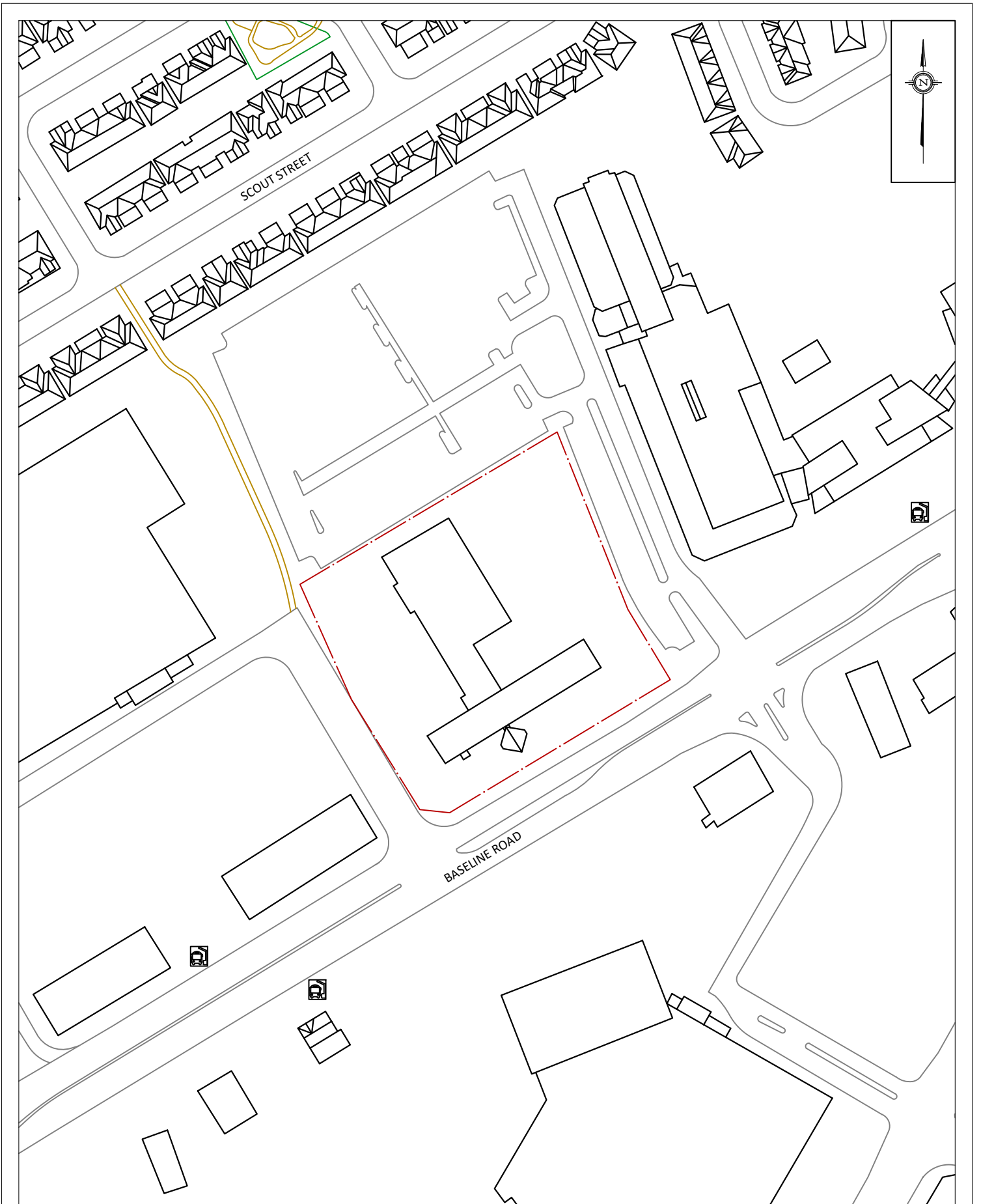

PROJECT	1345 BASELINE ROAD, OTTAWA PEDESTRIAN LEVEL WIND STUDY	
SCALE	1:2000	DRAWING NO. 22-147-PLW-1B
DATE	MAY 26, 2022	DRAWN BY S.K.

DESCRIPTION	FIGURE 1B: EXISTING SITE PLAN AND SURROUNDING CONTEXT
-------------	--

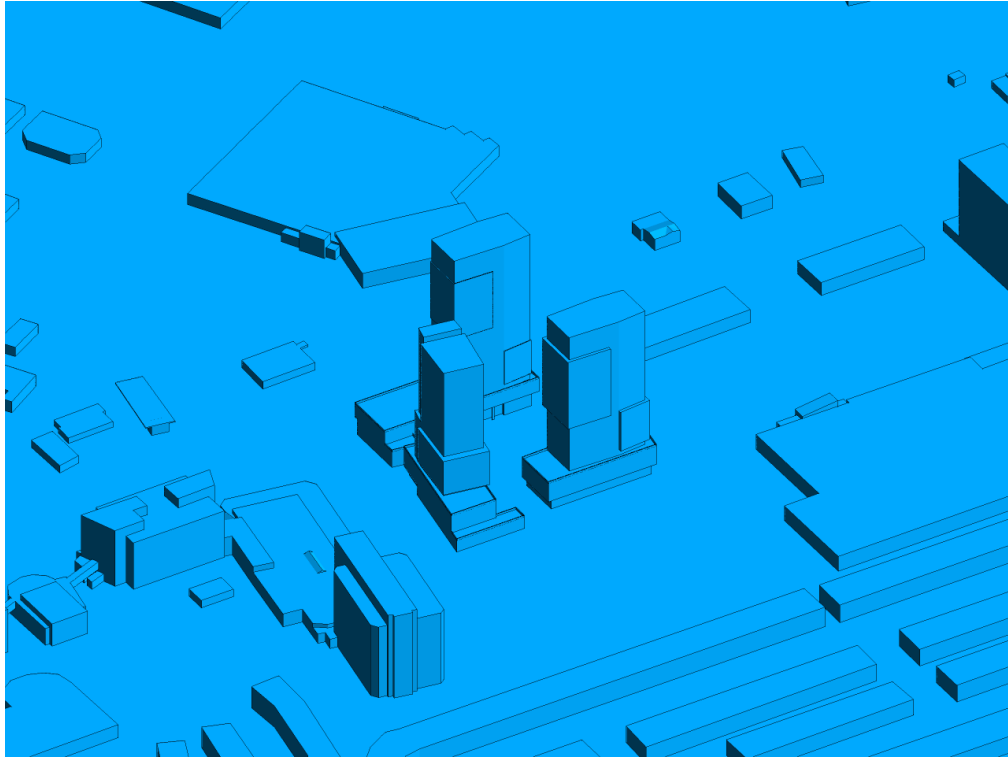

FIGURE 2A: COMPUTATIONAL MODEL, PROPOSED MASSING, NORTH PERSPECTIVE

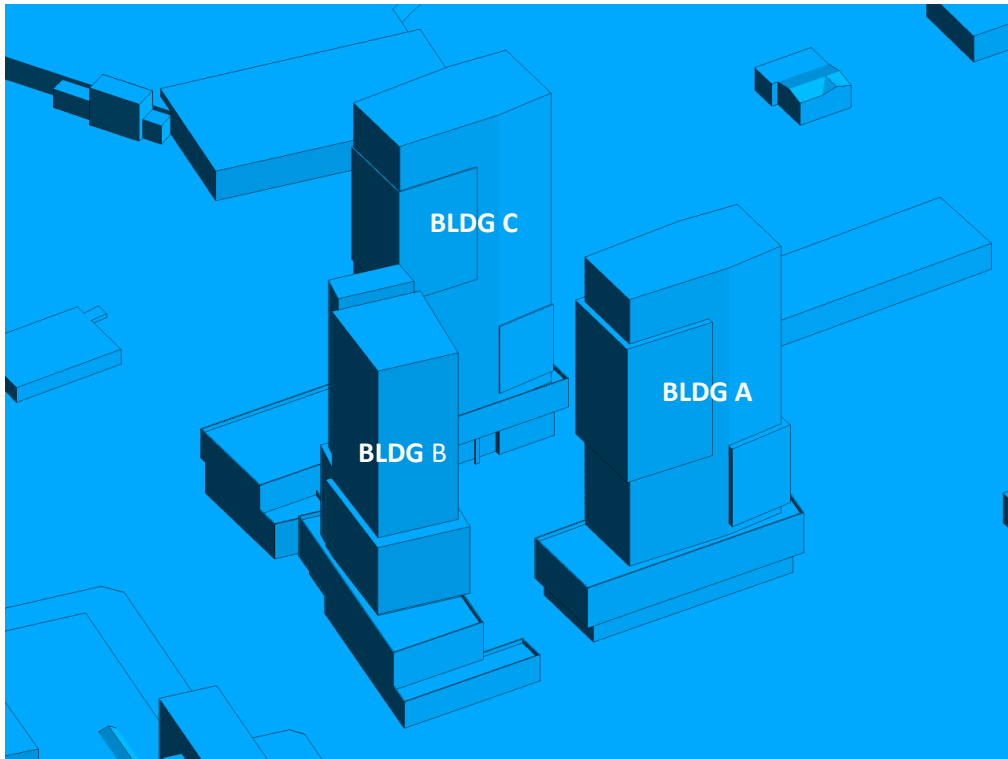

FIGURE 2B: CLOSE UP OF FIGURE 2A

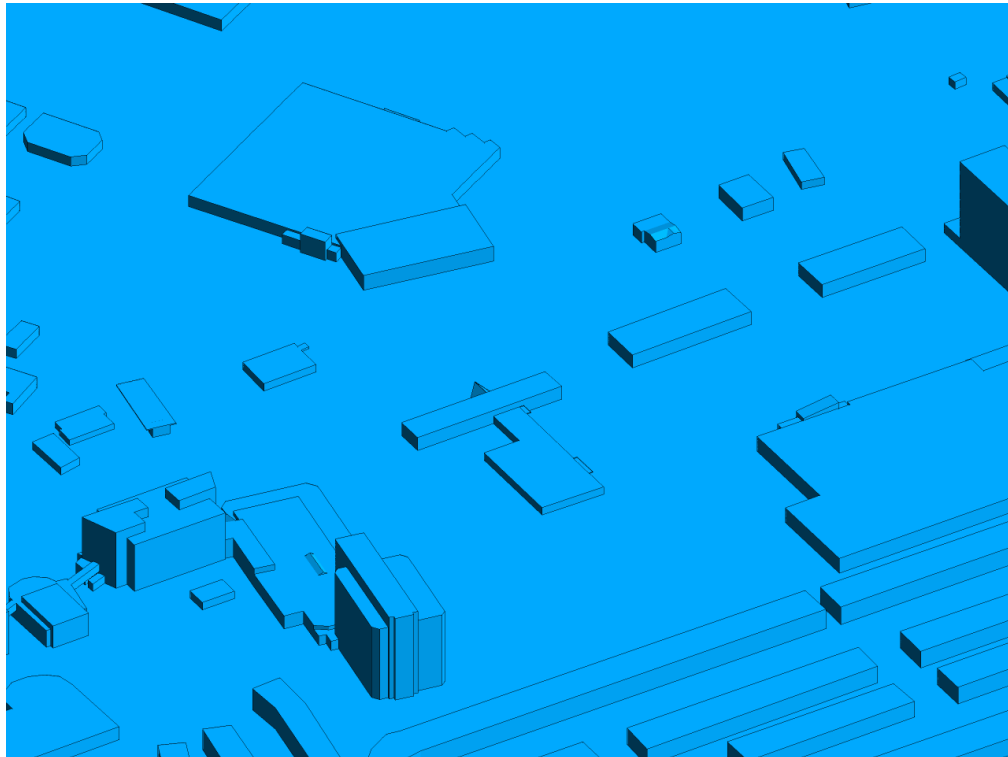

FIGURE 2C: COMPUTATIONAL MODEL, EXISTING MASSING, NORTH PERSPECTIVE

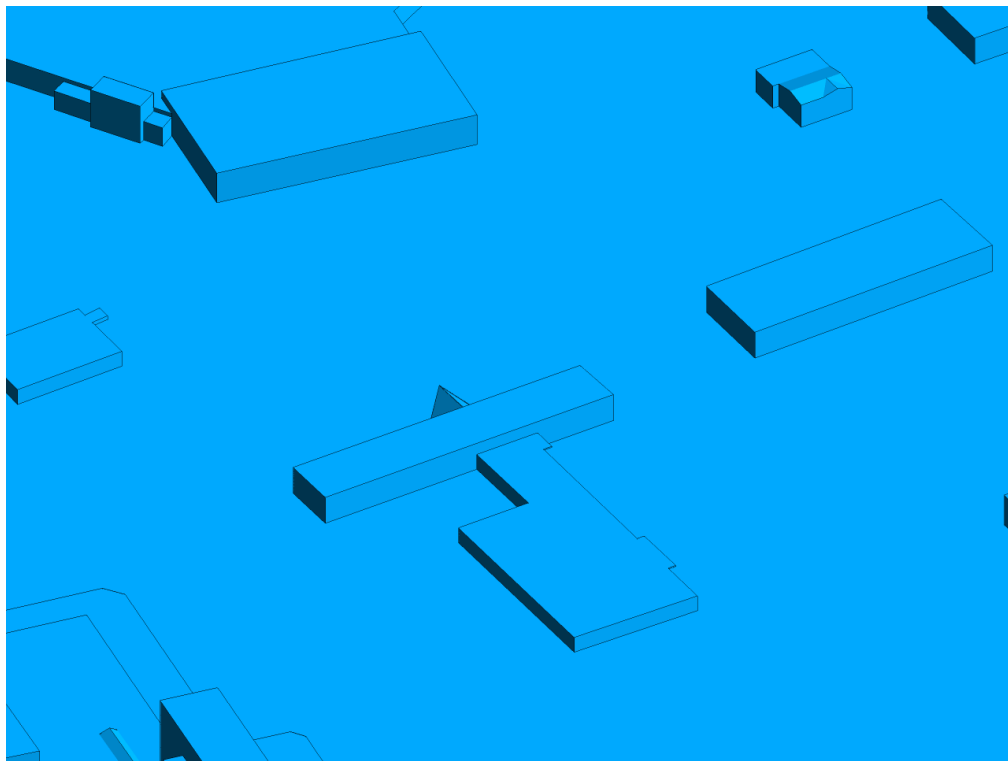

FIGURE 2D: CLOSE UP OF FIGURE 2C



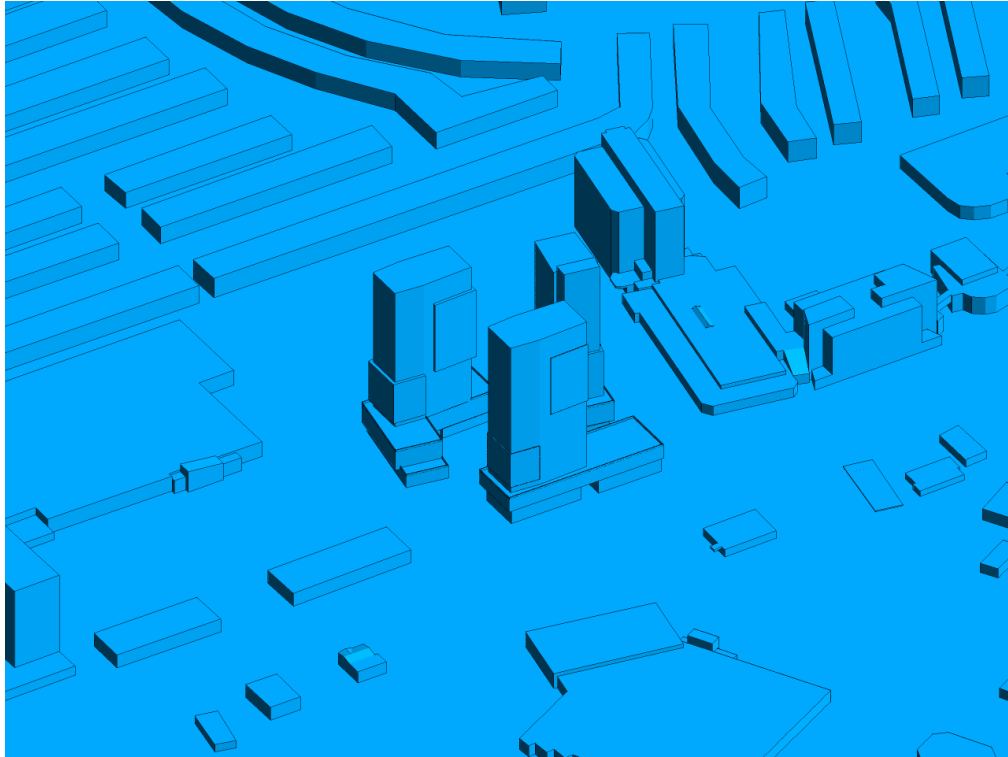

FIGURE 2E: COMPUTATIONAL MODEL, PROPOSED MASSING, SOUTH PERSPECTIVE

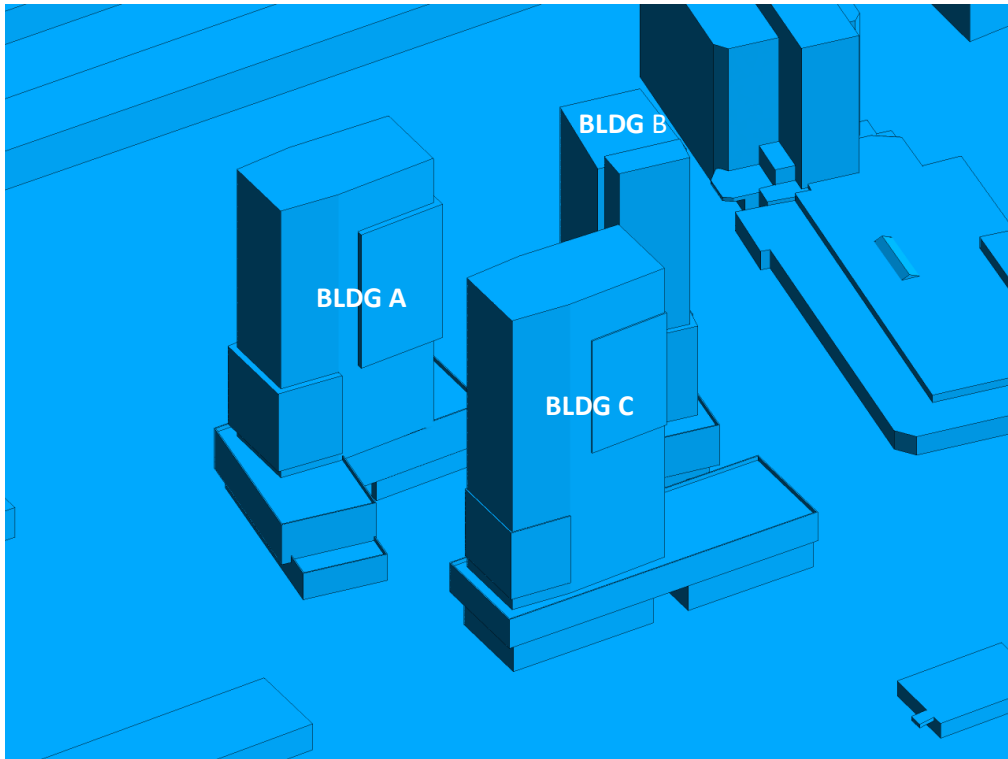

FIGURE 2F: CLOSE UP OF FIGURE 2E



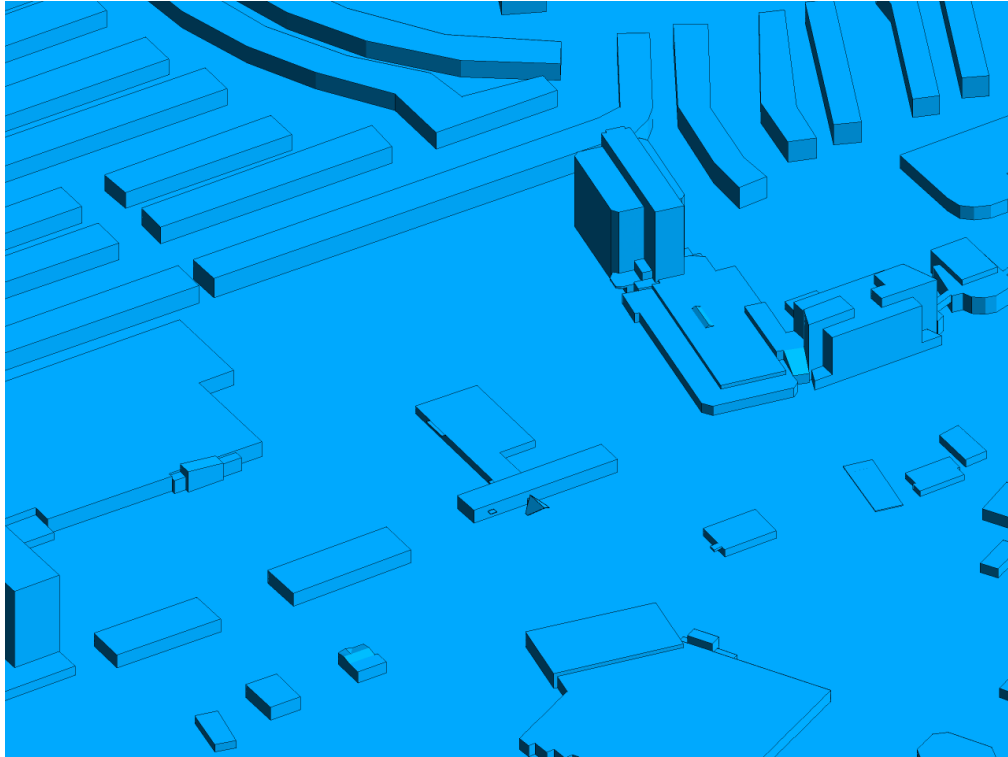

FIGURE 2G: COMPUTATIONAL MODEL, EXISTING MASSING, SOUTH PERSPECTIVE

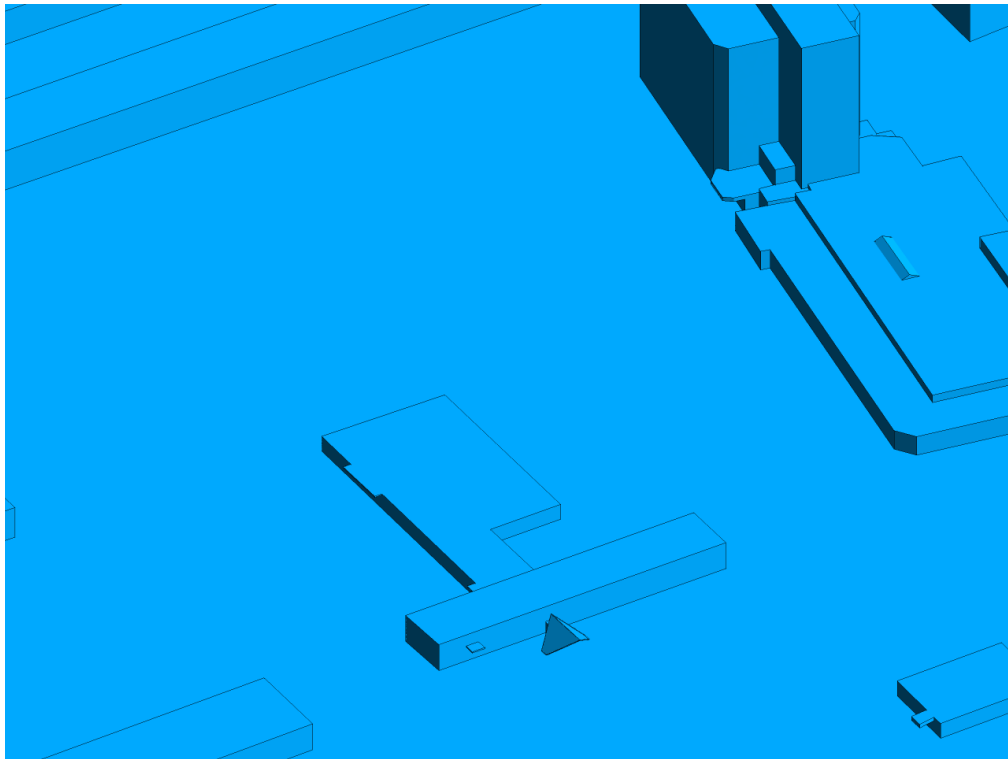

FIGURE 2H: CLOSE UP OF FIGURE 2G



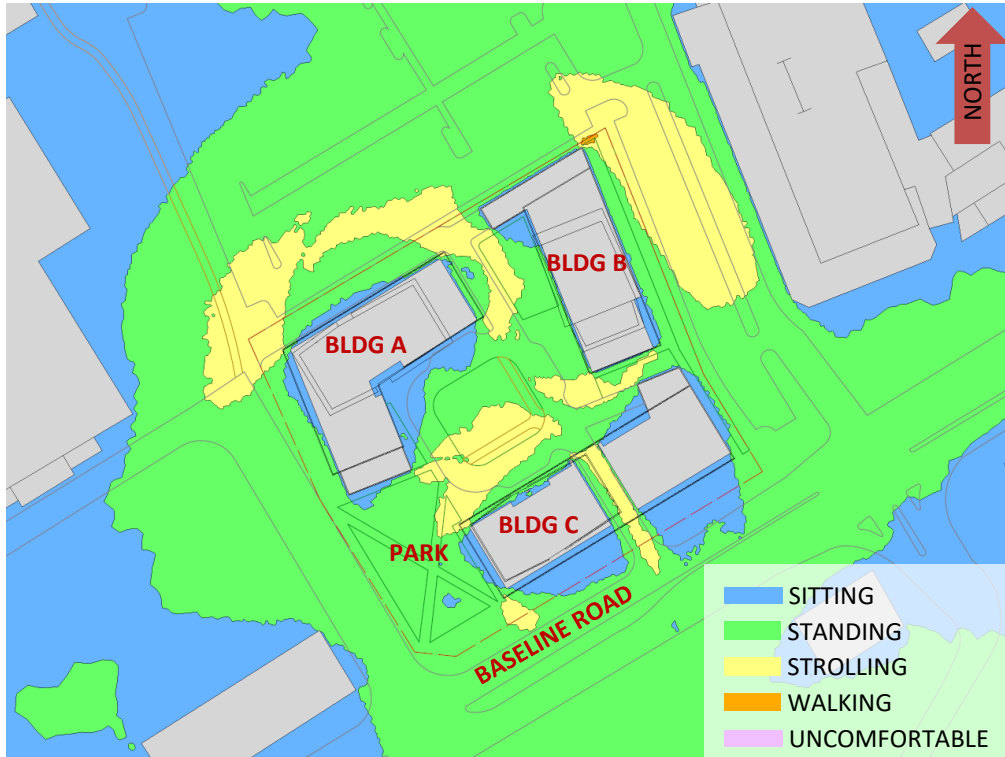

FIGURE 3A: SPRING – WIND COMFORT, GRADE LEVEL – PROPOSED MASSING

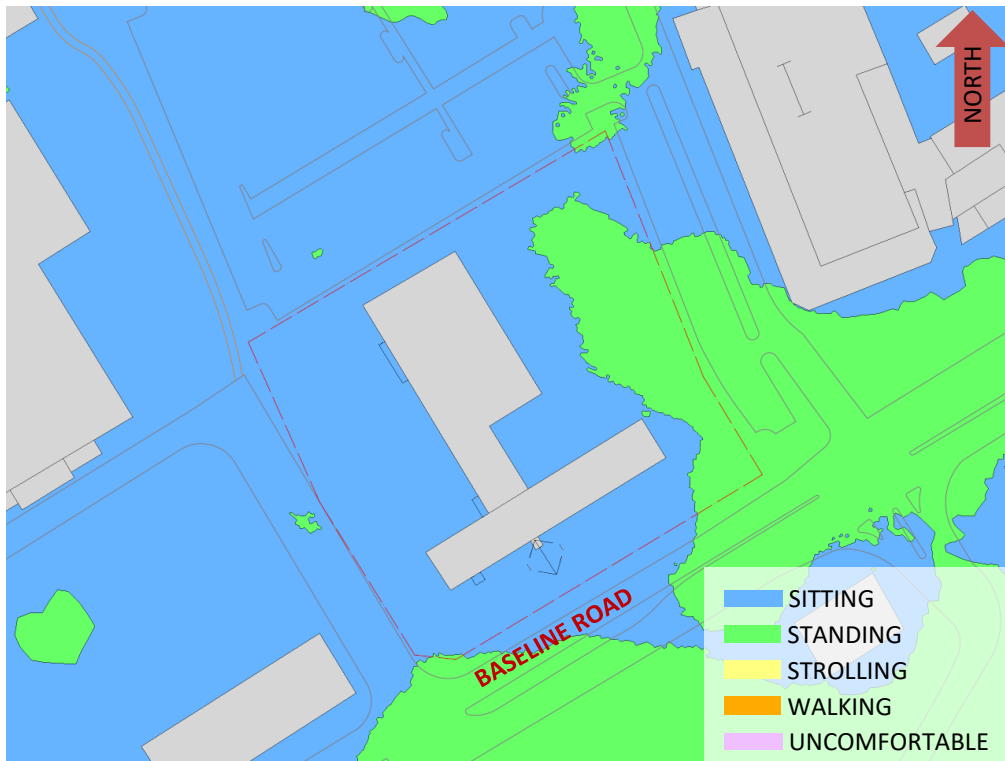

FIGURE 3B: SPRING – WIND COMFORT, GRADE LEVEL – EXISTING MASSING



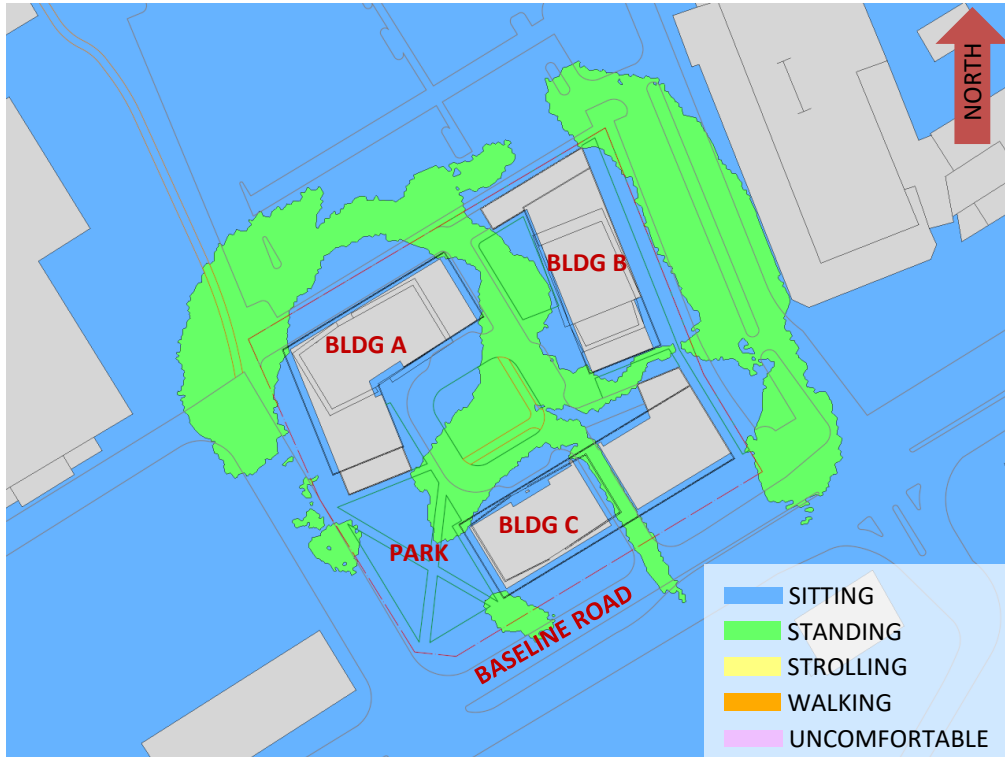

FIGURE 4A: SUMMER – WIND COMFORT, GRADE LEVEL – PROPOSED MASSING

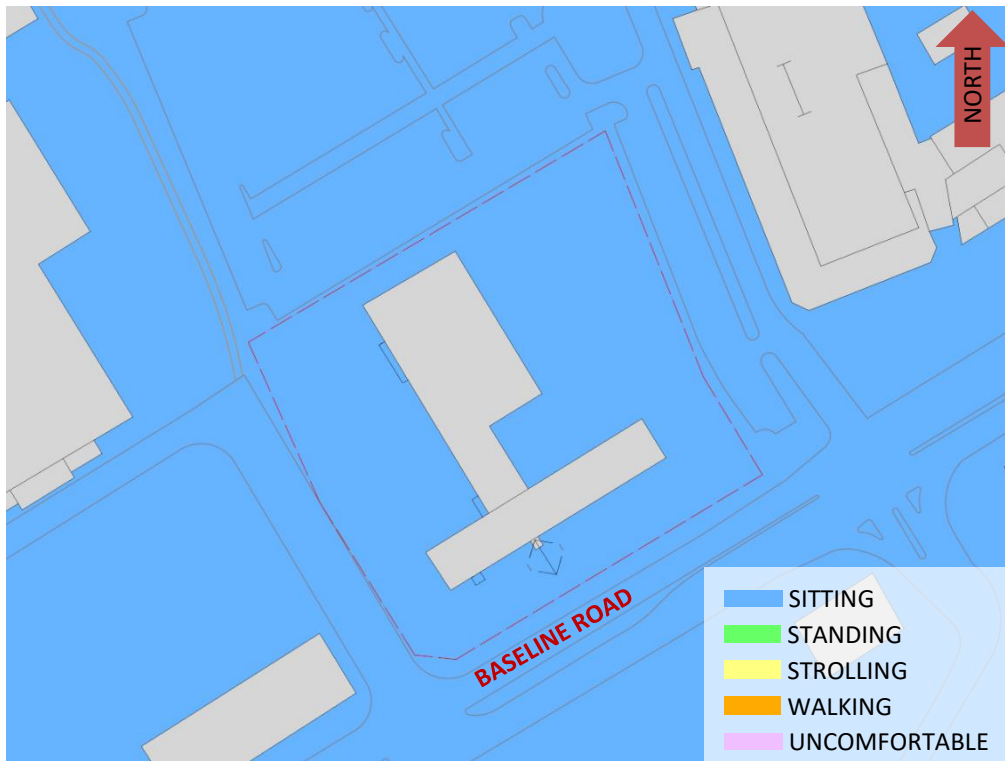

FIGURE 4B: SUMMER – WIND COMFORT, GRADE LEVEL – EXISTING MASSING



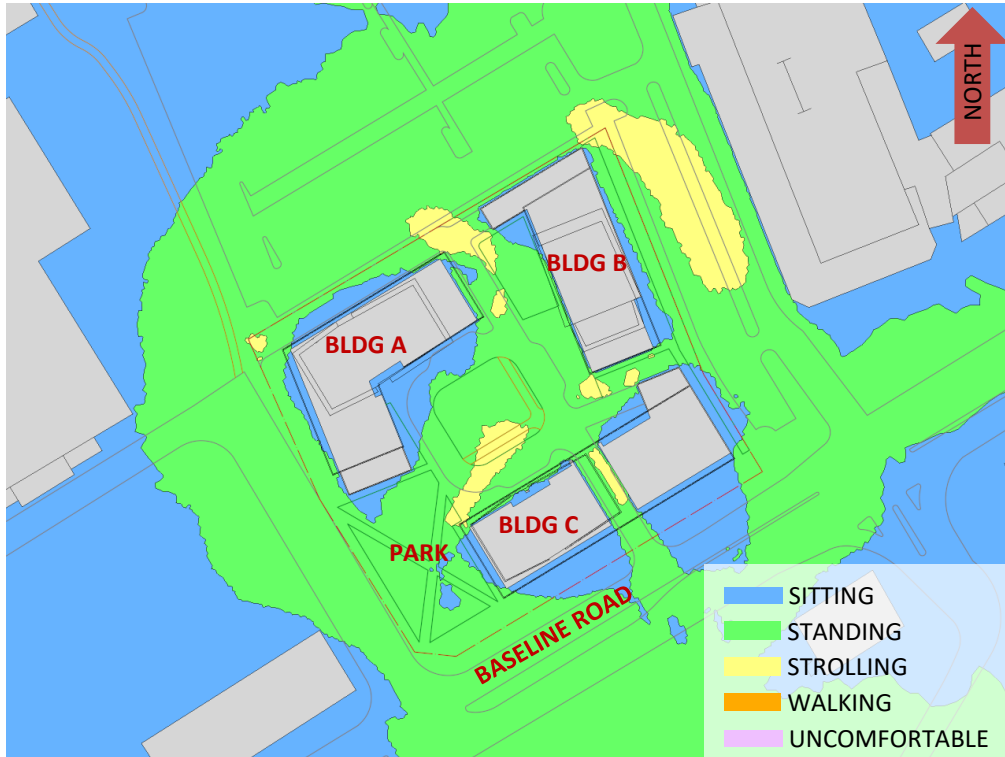

FIGURE 5A: AUTUMN – WIND COMFORT, GRADE LEVEL – PROPOSED MASSING

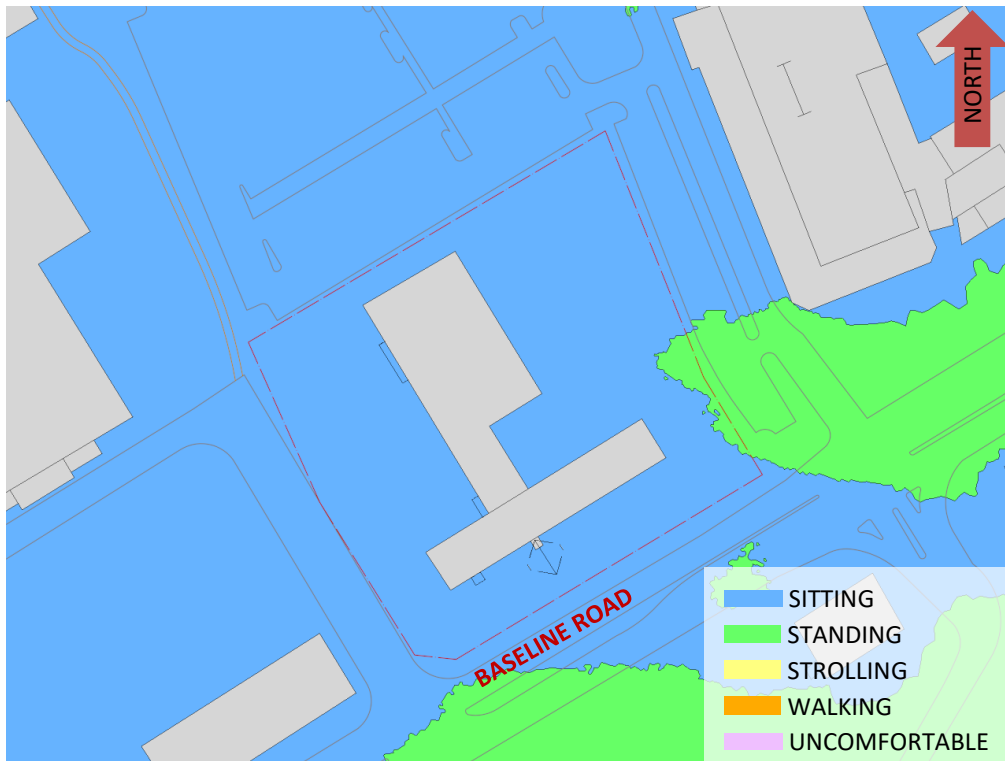

FIGURE 5B: AUTUMN – WIND COMFORT, GRADE LEVEL – EXISTING MASSING



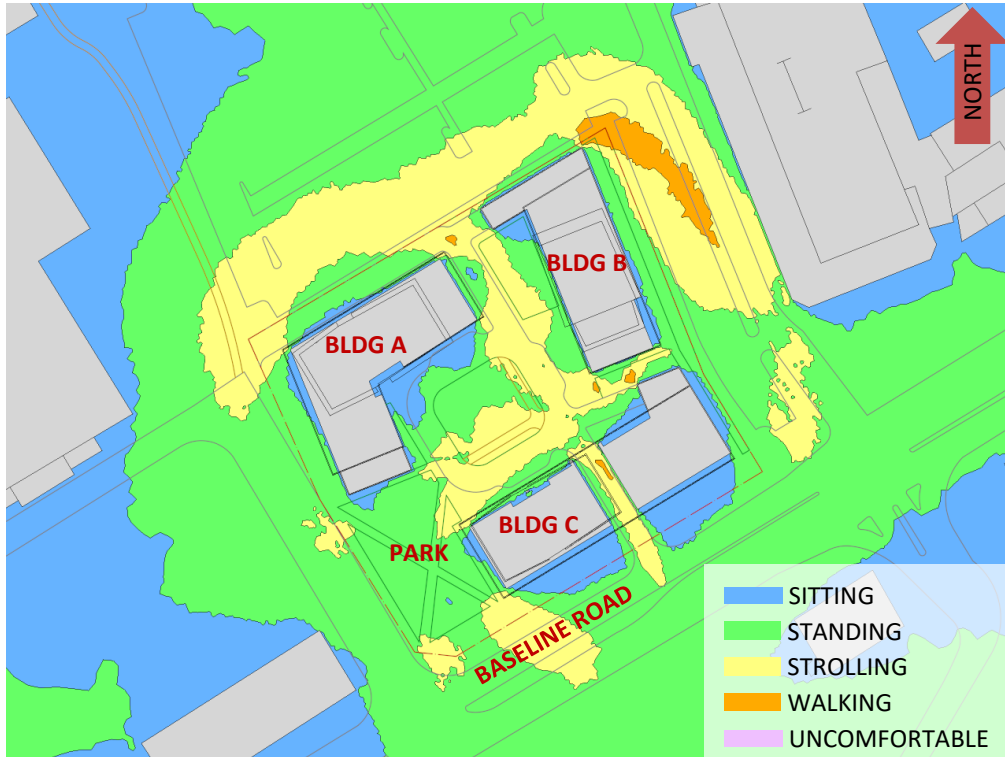

FIGURE 6A: WINTER – WIND COMFORT, GRADE LEVEL – PROPOSED MASSING

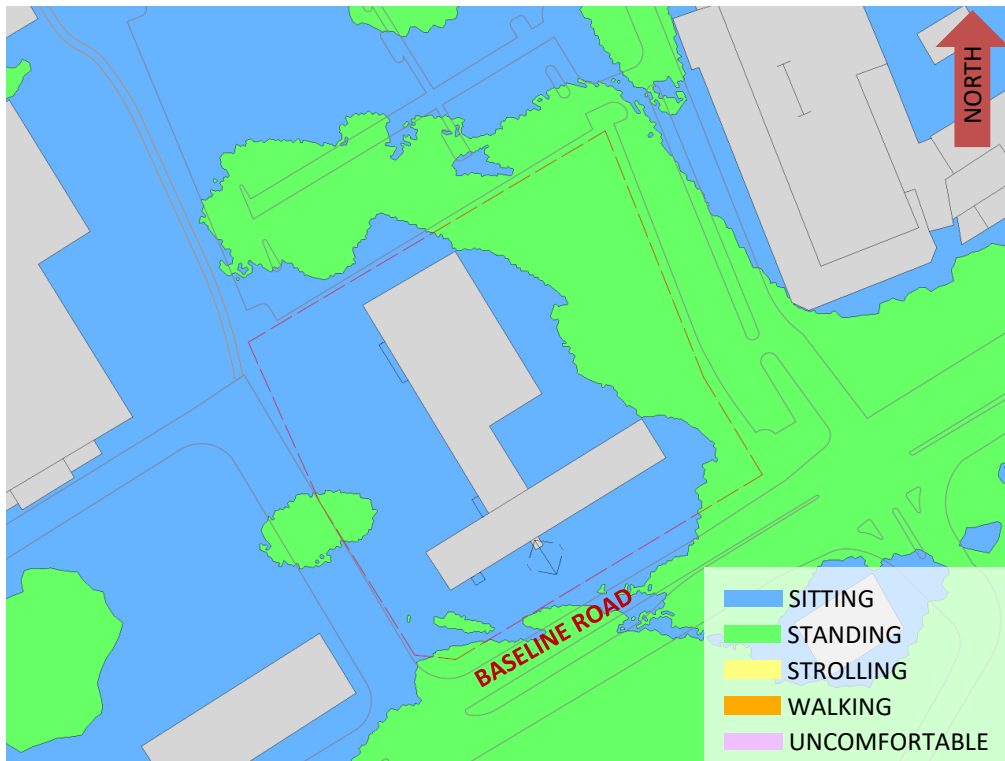

FIGURE 6B: WINTER – WIND COMFORT, GRADE LEVEL – EXISTING MASSING



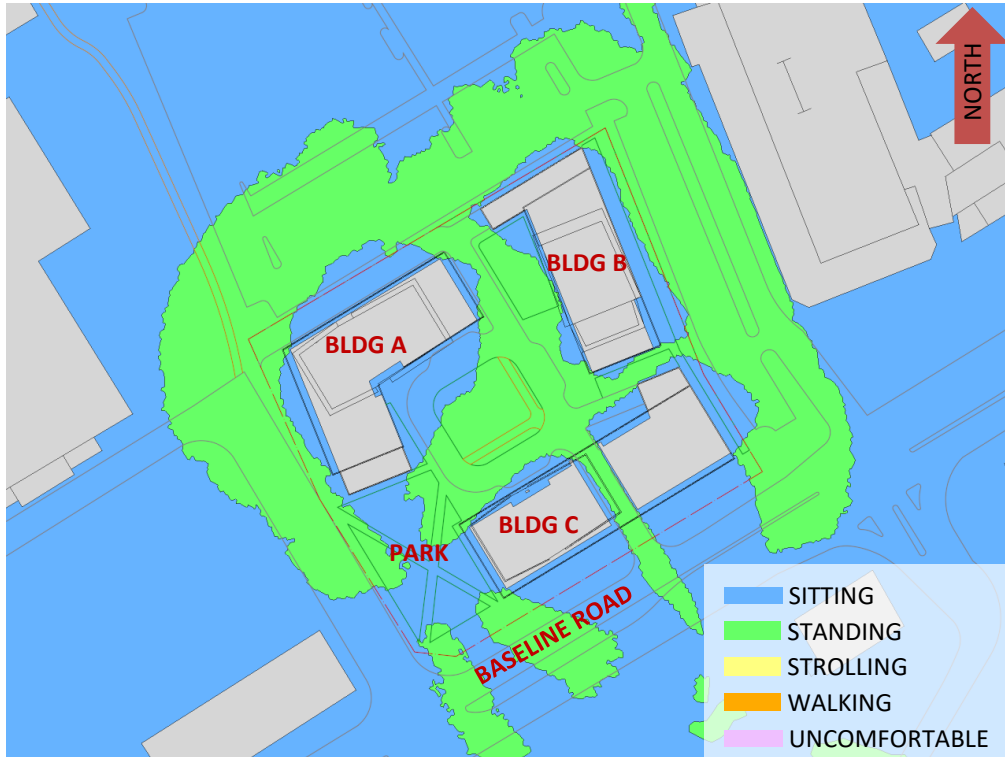

FIGURE 7A: TYPICAL USE PERIOD – WIND COMFORT, GRADE LEVEL – PROPOSED MASSING

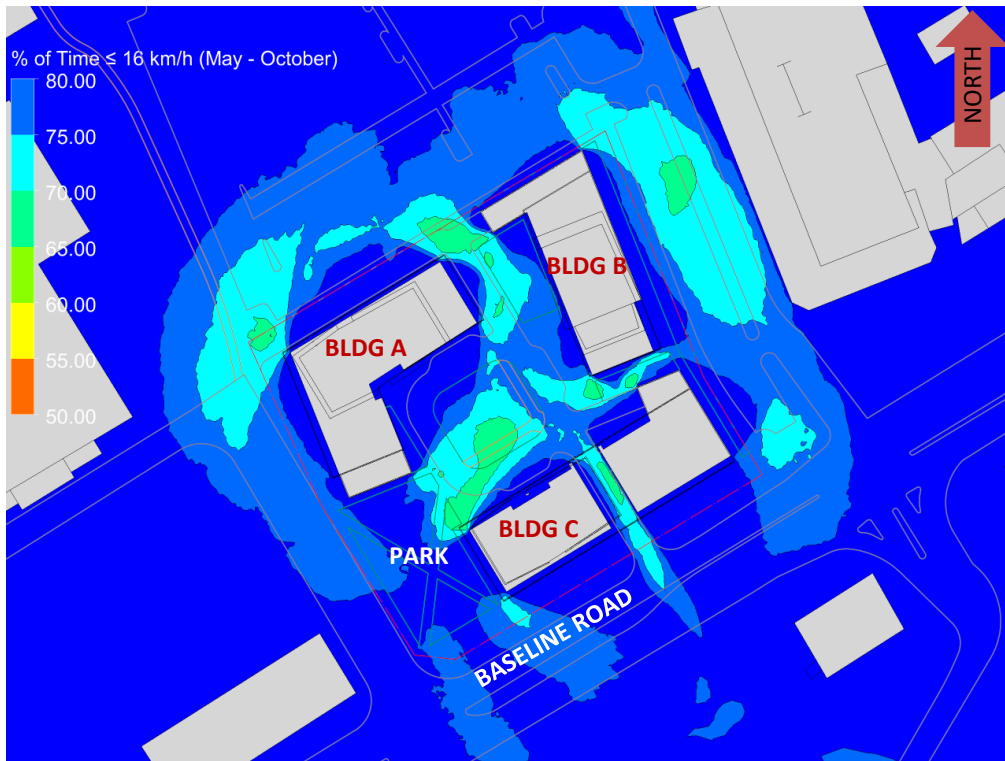

FIGURE 7B: PERCENTAGE OF TIME SUITABLE FOR SITTING IN FIGURE 7A



GRADIENTWIND

ENGINEERS & SCIENTISTS



APPENDIX A

SIMULATION OF THE ATMOSPHERIC BOUNDARY LAYER

SIMULATION OF THE ATMOSPHERIC BOUNDARY LAYER

The atmospheric boundary layer (ABL) is defined by the velocity and turbulence profiles according to industry standard practices. The mean wind profile can be represented, to a good approximation, by a power law relation, Equation (1), giving height above ground versus wind speed (1), (2).

$$U = U_g \left(\frac{Z}{Z_g} \right)^\alpha \quad \text{Equation (1)}$$

where, U = mean wind speed, U_g = gradient wind speed, Z = height above ground, Z_g = depth of the boundary layer (gradient height), and α is the power law exponent.

For the model, U_g is set to 6.5 metres per second (m/s), which approximately corresponds to the 60% mean wind speed for Ottawa based on historical climate data and statistical analyses. When the results are normalized by this velocity, they are relatively insensitive to the selection of gradient wind speed.

Z_g is set to 540 m. The selection of gradient height is relatively unimportant, so long as it exceeds the building heights surrounding the subject site. The value has been selected to correspond to our physical wind tunnel reference value.

α is determined based on the upstream exposure of the far-field surroundings (i.e., the area that it not captured within the simulation model).

Table 1 presents the values of α used in this study, while Table 2 presents several reference values of α . When the upstream exposure of the far-field surroundings is a mixture of multiple types of terrain, the α values are a weighted average with terrain that is closer to the subject site given greater weight.

TABLE 1: UPSTREAM EXPOSURE (ALPHA VALUE) VS TRUE WIND DIRECTION

Wind Direction (Degrees True)	Alpha Value (α)
0	0.24
49	0.19
74	0.22
103	0.24
167	0.23
197	0.23
217	0.24
237	0.24
262	0.24
282	0.24
301	0.23
324	0.22

TABLE 2: DEFINITION OF UPSTREAM EXPOSURE (ALPHA VALUE)

Upstream Exposure Type	Alpha Value (α)
Open Water	0.14-0.15
Open Field	0.16-0.19
Light Suburban	0.21-0.24
Heavy Suburban	0.24-0.27
Light Urban	0.28-0.30
Heavy Urban	0.31-0.33

The turbulence model in the computational fluid dynamics (CFD) simulations is a two-equation shear-stress transport (SST) model, and thus the ABL turbulence profile requires that two parameters be defined at the inlet of the domain. The turbulence profile is defined following the recommendations of the Architectural Institute of Japan for flat terrain (3).

$$I(Z) = \begin{cases} 0.1 \left(\frac{Z}{Z_g} \right)^{-\alpha-0.05}, & Z > 10 \text{ m} \\ 0.1 \left(\frac{10}{Z_g} \right)^{-\alpha-0.05}, & Z \leq 10 \text{ m} \end{cases} \quad \text{Equation (2)}$$

$$L_t(Z) = \begin{cases} 100 \text{ m} \sqrt{\frac{Z}{30}}, & Z > 30 \text{ m} \\ 100 \text{ m}, & Z \leq 30 \text{ m} \end{cases} \quad \text{Equation (3)}$$

where, I = turbulence intensity, L_t = turbulence length scale, Z = height above ground, and α is the power law exponent used for the velocity profile in Equation (1).

Boundary conditions on all other domain boundaries are defined as follows: the ground is a no-slip surface; the side walls of the domain have a symmetry boundary condition; the top of the domain has a specified shear, which maintains a constant wind speed at gradient height; and the outlet has a static pressure boundary condition.

REFERENCES

- [1] P. Arya, "Chapter 10: Near-neutral Boundary Layers," in *Introduction to Micrometeorology*, San Diego, California, Academic Press, 2001.
- [2] S. A. Hsu, E. A. Meindl and D. B. Gilhousen, "Determining the Power-Law Wind Profile Exponent under Near-neutral Stability Conditions at Sea," vol. 33, no. 6, 1994.
- [3] Y. Tamura, H. Kawai, Y. Uematsu, K. Kondo and T. Okhuma, "Revision of AIJ Recommendations for Wind Loads on Buildings," in *The International Wind Engineering Symposium, IWES 2003*, Taiwan, 2003.