



Jp2g Consultants Inc.

ENGINEERS • PLANNERS • PROJECT MANAGERS

1150 Morrison Drive, Suite 410, Ottawa, ON K2H 8S9
T 613-828-7800, F 613-828-2600, www.jp2g.com

1150 Morrison Drive, Suite 410
Ottawa, ON, K2H 8S9
T.613.828.7800 F.613.828.2600
Project No. 21-1062A

Site Servicing and Stormwater Management Report

Wilbrod Street Apartment Complex

326-332 Wilbrod St, Ottawa, Ontario

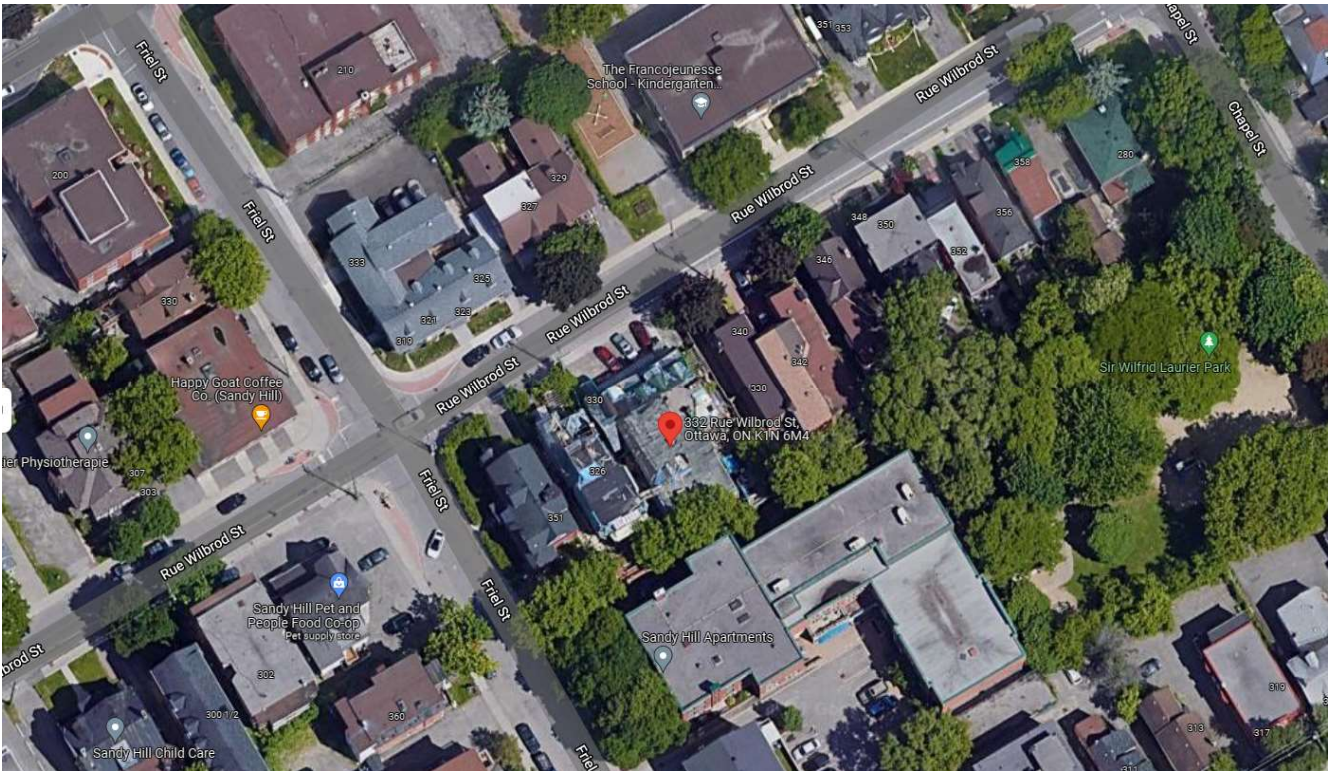

Prepared for

Dolyn Developments Inc. and Dolyn Construction Ltd.
888 Lady Ellen Place, Unit #1
Ottawa, Ontario, K1Z 5L5

SUBMISSION March 9, 2022



Table of Contents

1	Introduction	1
1.1	Design Drawings	1
1.2	Design Population	1
2	Objective	1
3	Stormwater Management	1
3.1	Pre-Development Conditions	1
3.2	Allowable Release Rate	2
3.3	Post-Development Conditions	2
3.4	Storm Sewer Pipe Design	2
3.5	Stormwater Quality Control	2
3.6	Stormwater Quantity Control	2
4	Sanitary Servicing	3
5	Water	3
5.1	Fire Flow Demand	4
❖	Appendix A	Drawings and Figures
❖	Appendix B	Stormwater Management Calculations
❖	Appendix C	Sanitary Servicing Calculations
❖	Appendix D	Fire Flow Demand Calculations
❖	Appendix E	Pre-Consultation & Development Servicing Study Checklist
❖	Appendix F	Roof Drain Product Data Sheet



1 Introduction

Jp2g Consultants Inc. was retained by Dolyn Developments Inc. and Dolyn Construction Ltd. to complete a Site Servicing and Stormwater Management Report suitable for the City of Ottawa Site Plan Control Application, for a new apartment complex development located at the southeast corner of Friel Street and Wilbrod Street Ottawa, ON.

The site is approximately **0.90 ha** in size and is bound by Wilbrod Street on the north property limit. The proposed development includes the construction of a new **470 m²** Four-storey apartment unit with a mechanical basement, and associated parking and landscaped areas.

A Pre-Consultation meeting was held with City of Ottawa staff on November 22, 2021, to determine the project constraints and requirements. The following report details the site servicing & stormwater management calculations used for capacity, water quantity and quality control in accordance with the City of Ottawa's requirements.

1.1 Design Drawings

The following reference civil design drawings are included.

- C1 – Site Servicing Plan
- C2 – Grading Plan
- Figure 1 – Pre-Development Storm Drainage Areas
- Figure 2 – Post-Development Storm Drainage Areas

1.2 Design Population

The estimated population for the proposed development is as follows using the general population densities in accordance to Table 4.2 from the City of Ottawa Sewer Design Guidelines:

Table 1: Design Population

Apartment Unit Type		Design Population (persons)
1 Bedroom / Bachelor Apartment Units (1.4 persons per unit)	2 Bedroom Apartment Units (2.1 persons per unit)	
14	26	75

2 Objective

This study will outline the servicing requirements for the development and identify the impact of the development on the existing municipal services, including water, storm and sanitary.

The stormwater management plan is to control post-development peak flows to pre-determined levels, and detain onsite, stormwater up to and including the 100-year storm event with a 25% increase of rainfall intensity (hereby referred to as 100-year* storm event) without affecting adjacent lands.

3 Stormwater Management

3.1 Pre-Development Conditions

The existing site consists of two developed residential and commercial parcels. The parcels are bounded by existing residential units on all sides.



3.2 Allowable Release Rate

Based on existing conditions the site appears to be completely hard surface, however 10% of the site was assumed to be soft surface prior to past expansions/renovations. As a result, the pre-development runoff coefficient of 0.83 an allowable release rate of $Q_{\text{allowable}} = 23.4 \text{ l/s}$ was calculated for the new site, see attached [Appendix B](#).

3.3 Post-Development Conditions

The proposed site development includes a new apartment building, asphalt parking, hard surface walkways and landscaped areas. Site storm drainage will be conveyed through the new on-site storm sewer and connect to the existing **375mm** storm sewer on Wilbrod Street. Flows will be managed to limit the 100-year post-development flow rate to the pre-development 5-year release rate identified in section 3.2.

The site development area is approximately **0.90 ha** with a post-development average weighted run-off coefficient of $C = 0.75$ and $C = 0.84$ for the 5-year and 100-year* storm events, respectively. Refer to calculations in [Appendix B](#). Stormwater management techniques are required to reduce peak flows from the area, given that post-development peak flows will exceed the pre-development allowable release rate of **23.4 l/s**.

3.4 Storm Sewer Pipe Design

Pipe diameter sizing was based on the **5-year** and **100-year** storm event, in accordance with City requirements. Under 5-year conditions, the storm sewers are not in surcharged conditions (i.e. flow/capacity <100%).

3.5 Stormwater Quality Control

No stormwater quality control will be provided for this development.

3.6 Stormwater Quantity Control

Drainage areas B2 and B3, North and West property frontage, parking lot and side access areas will all flow uncontrolled. Refer to [Figure 2](#).

Table 2: Allowable Release Rate Breakdown

ID	Description	Flows	
		5-Year Event	100-Year Event
	Allowable Release Rate (Section 3.2)	23.4 L/s	44.5 L/s
1.2.1	Uncontrolled flow	7.3 L/s	14.1 L/s
1.2.2	Net-allowable release rate	16.1 L/s	9.3 L/s*

* Note: Must be controlled to net-allowable 100-year.

To meet the net-allowable release rate, flows will be detained only on the school roof by installing parabolic weirs, (Watts Drainage Adjustable Flow Control for Roof Drains, or equivalent approved product), at all roof drains limiting the total flow from the roof to **9.3 L/s** for both the **5-year and 100-year**, which is equal to the net-allowable release rate. On-site storage requirements for the roof were calculated to be **2m³** for the 5-year storm event and **8m³** for the 100-year storm event. The maximum available storage for the roof was calculated to be **23m³** based on a maximum ponding depth of 150mm. Refer to [Appendix G](#) product data sheets.

No on-site storage is required in the parking area. In the event the capacity of this system is exceeded, emergency runoff will overflow north through the side access entrance to Wilbrod Street. The maximum ponding depth in parking lots is up to 350mm which is in accordance to the City of Ottawa requirements.



4 Sanitary Servicing

A new **200mm** sanitary sewer conveying flows from the new building will connect to the existing **600mm** will be constructed by others on Wilbrod Street. Refer to drawing **C1 – Site Servicing Plan**.

Based on the existing commercial and residential building on-site, pre-development peak sanitary flow for the site is calculated to be **0.11 L/s**. Post-development peak sanitary flow for the site is calculated to be **1.00 l/s**. The new **200mm** sanitary sewers at minimum **1.0%** slope will have a full flow capacity of **32.8 l/s**. The sanitary demand was calculated based on the *City of Ottawa Sewer Design Guidelines 2012* and *Technical Bulletins 2018*. Refer to **Appendix C** for full calculations.

There will be a small sanitary demand increase outletting into the municipal **600mm** sanitary sewer for post-development conditions.

5 Water

A **100mm** watermain will service the new building and connect to the existing **300mm** watermain on Wilbrod Street.

The domestic water demand for the new apartment complex is calculated based on Table 4.2 of the *City of Ottawa Design Guidelines for Water Distribution*.

Existing Development Calculations:

Cumulative Maximum Daily Demand: **0.02 l/s + 0.09 L/s = 0.11 L/s**

Cumulative Maximum Hour Demand: **0.04 l/s + 0.16 L/s = 0.20 L/s**

See calculation breakdown below.

Commercial Parcel

- Gross Commercial Area = 0.06 hectares
- Maximum Day Factor = 1.5
- Maximum Hour Factor = 1.8
- Average daily demand for commercial = 28,000 L/ha/day
- Day = 8 hours

Average Daily Demand: $\frac{28,000 \text{ L/ha/day} \times 0.06 \text{ ha}}{8 \text{ hrs/day} \times 3600 \text{ s/hr}} = 0.06 \text{ L/s}$

Maximum Daily Demand: $0.06 \text{ L/s} \times 1.5 = 0.09 \text{ L/s}$

Maximum Hour Demand: $0.06 \text{ L/s} \times 1.8 = 0.16 \text{ L/s}$

Residential Parcel

- Average daily demand = 280 l/capita/day
- Operational Hours = 24 hours
- Maximum occupancy = 4 persons (residents)
- Maximum Day Factor = 1.5
- Maximum Hour Factor = 1.8

Average Daily Demand: $\frac{280 \text{ l/capita/day} \times 4 \text{ residents}}{24 \text{ hrs/day} \times 3600 \text{ s/hr}} = 0.013 \text{ l/s}$

Maximum Daily Demand: $0.013 \text{ l/s} \times 1.5 = 0.02 \text{ l/s}$

Maximum Hour Demand: $0.02 \text{ l/s} \times 1.8 = 0.04 \text{ l/s}$



New Development Calculations:

- Average daily demand = 280 l/capita/day
- Operational Hours = 24 hours
- Maximum occupancy = 75 persons (residents)
- Maximum Day Factor = 1.5
- Maximum Hour Factor = 1.8

Average Daily Demand: $\frac{280 \text{ l/capita/day} \times 75 \text{ residents}}{24 \text{ hrs/day} \times 3600 \text{ s/hr}} = 0.24 \text{ l/s}$

Maximum Daily Demand: $0.24 \text{ l/s} \times 1.5 = 0.36 \text{ l/s}$

Maximum Hour Demand: $0.36 \text{ l/s} \times 1.8 = 0.65 \text{ l/s}$

There will be a small water demand increase drawing from the municipal **300mm** watermain for post-development conditions.

5.1 Fire Flow Demand

Based on the Fire Underwriters Survey Method, the fire flow demand for the new development is calculated to be:

Fire Flow Demand: **100.0 l/s** (Refer to Appendix B – Fire Flow Calculations).

There is one (1) fire hydrant across the street on Wilbrod within 45.0m and three (3) fire hydrants along Wilbrod Street and Friel Street within 75.0m to 150.0m from the subject property. All fire hydrants are class AA and provide a cumulative fire flow contribution of **158.33 L/s** which is based on Table 1 of Appendix I in Technical Bulletin ISTB-2018-02. The new building will also be equipped with an automatic sprinkler system.

As a result, the available fire flow contribution meets the fire flow demand of the new development.

End of Site Servicing and Stormwater Management Report.

Please contact the undersigned should you require any clarification.

Prepared By:



Patrick Ha, P. Eng.
Civil Engineer
patrickh@jp2g.com
613-828-7800

Appendix A - Drawings and Figures

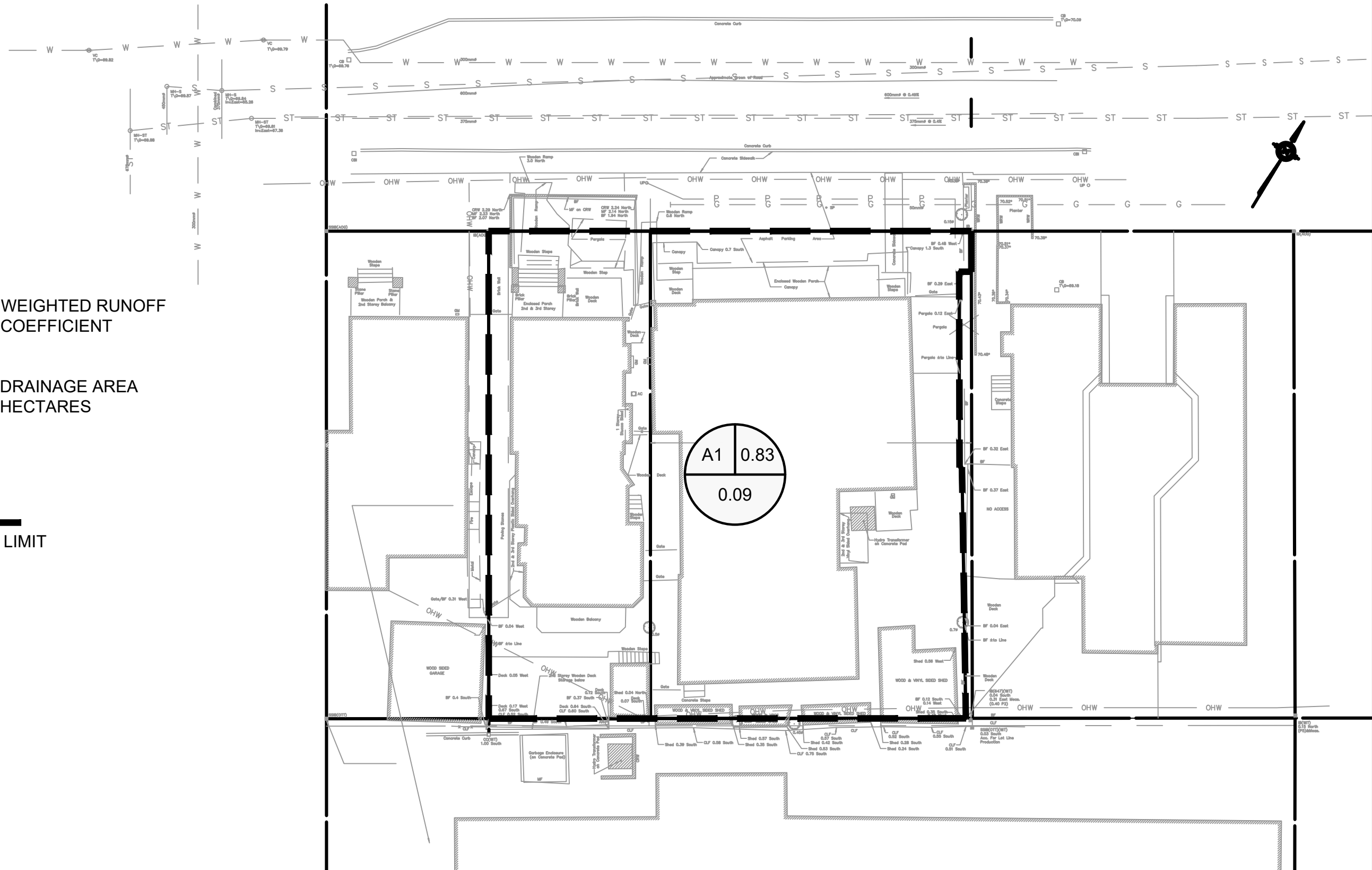
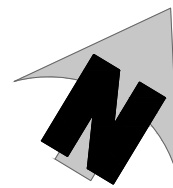

DRAINAGE AREA ID

WEIGHTED RUNOFF COEFFICIENT

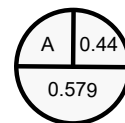

DRAINAGE AREA HECTARES

— — — — —
DRAINAGE AREA LIMIT

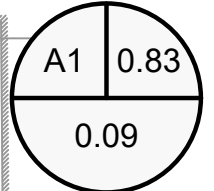

WILBROD APARTMENT BUILDING
326-330 WILBROD STREET, OTTAWA, ONTARIO

FIGURE 1 - PRE-DEVELOPMENT DRAINAGE AREA

Jp2g Consultants Inc.
ENGINEERS • PLANNERS • PROJECT MANAGERS

12 INTERNATIONAL DRIVE, PEMBROKE, ON 1150 MORRISON DRIVE, SUITE 410, OTTAWA, ON
Phone: (613)735-2507, Fax: (613)735-4513 Phone: (613)828-7800, Fax: (613)828-2600

DESIGNED: PH	PROJECT No.: 21-1062A
DRAFTED: PH	REVISION DATE:
CHECKED: DN	APPROVED: DN
SCALE: 1:250	REVISION No.: .

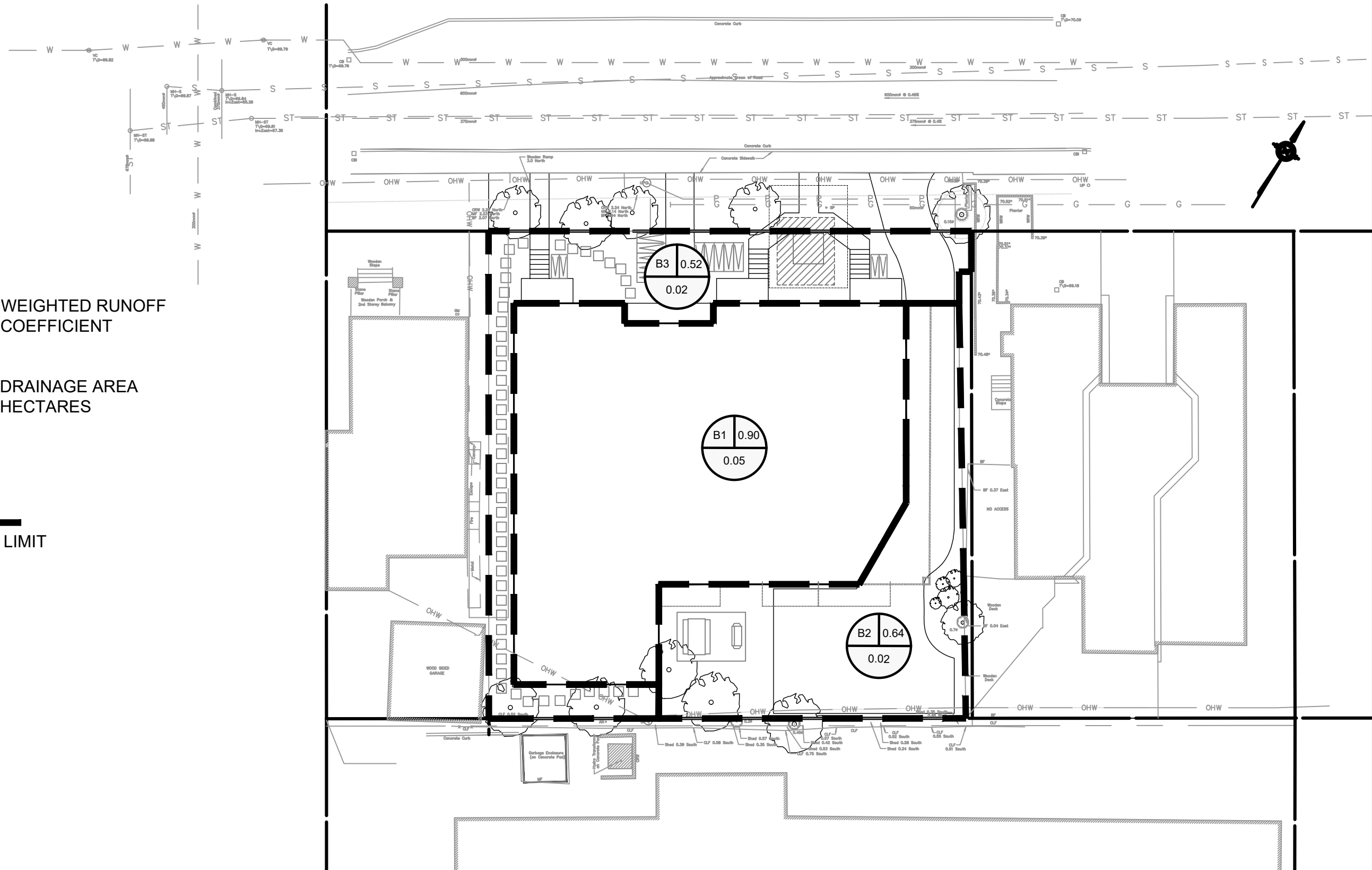
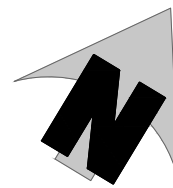

DRAINAGE AREA ID

WEIGHTED RUNOFF COEFFICIENT

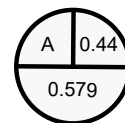

DRAINAGE AREA HECTARES

— — — — —
DRAINAGE AREA LIMIT

WILBROD APARTMENT BUILDING
326-330 WILBROD STREET, OTTAWA, ONTARIO

FIGURE 2 - POST-DEVELOPMENT DRAINAGE AREA

Jp2g Consultants Inc.
ENGINEERS • PLANNERS • PROJECT MANAGERS

12 INTERNATIONAL DRIVE, PEMBROKE, ON Phone: (613)735-2507, Fax: (613)735-4513
1150 MORRISON DRIVE, SUITE 410, OTTAWA, ON Phone: (613)828-7800, Fax: (613)828-2600

DESIGNED: PH	PROJECT No.: 21-1062A
DRAFTED: PH	REVISION DATE:
CHECKED: DN	APPROVED: DN
SCALE: 1:250	REVISION No.: .

LEGEND	
	PROPERTY LINE
	EXISTING BUILDING
	EXISTING SANITARY SEWER
	EXISTING STORM SEWER
	EXISTING WATERMAIN
	EXISTING SANITARY MANHOLE
	EXISTING STORM MANHOLE
	EXISTING CATCHBASIN
	EXISTING WATERMAIN VALVE
	EXISTING FIRE HYDRANT
	EXISTING OVERHEAD WIRES
	EXISTING UNDERGROUND UTILITY
	EXISTING UNDERGROUND GASMAIN
	NEW SANITARY SEWER
	NEW STORM SEWER
	NEW WATERMAIN
	NEW CATCHBASIN
	NEW CATCHBASIN MANHOLE
	NEW SANITARY MANHOLE
	NEW STORM MANHOLE
	NEW WATER VALVE
	NEW INLET CONTROL DEVICE
	NEW ROOF DRAIN
	NEW SCUPPER
	NEW LIGHT DUTY ASPHALT
	NEW HEAVY DUTY ASPHALT
	NEW CONCRETE SIDEWALK

GENERAL NOTES

- DESIGN AND CONSTRUCTION IS TO BE IN ACCORDANCE WITH MOST RECENT ONTARIO BUILDING CODE.
- THE CONTRACTOR IS RESPONSIBLE FOR CHECKING AND VERIFYING ALL DIMENSIONS WITH RESPECT TO SITE CONDITIONS AND ALL MATERIALS TO THE PROJECT. ANY DISCREPANCY SHALL BE REPORTED TO THE ENGINEER.
- THIS DRAWING IS TO BE READ IN CONJUNCTION WITH ALL MATERIAL RELEVANT TO THE PROJECT.
- ADDITIONAL DRAWINGS MAY BE ISSUED FOR CLARIFICATION TO ASSIST PROPER EXECUTION OF WORK. SUCH DRAWINGS WILL HAVE THE SAME MEANING AND INTENT AS IF THEY WERE INCLUDED WITH THE CONTRACT DOCUMENTS.
- CONTRACTOR MUST COMPLY WITH LOCAL BY-LAWS, ONTARIO OCCUPATIONAL HEALTH AND SAFETY ACT AND ALL REGULATIONS SET BY AUTHORITIES HAVING JURISDICTION. IN CASE OF CONFLICT OR DISCREPANCY, THE MORE STRINGENT REQUIREMENTS SHALL APPLY.
- CONTRACTOR RESPONSIBLE FOR OBTAINING ALL REQUIRED UTILITY LOCATES, DAYLIGHTING, INSPECTIONS, PERMITS, AND APPROVALS, INCLUDING ALL ASSOCIATED COSTS. LOCATION OF EXISTING UTILITIES ARE APPROXIMATE ONLY AND BASED ON BEST AVAILABLE INFORMATION.

EROSION AND SEDIMENT CONTROL NOTES

- THE CONTRACTOR SHALL IMPLEMENT BEST MANAGEMENT PRACTICES TO PROVIDE FOR PROTECTION OF THE AREA DRAINAGE SYSTEM AND THE RECEIVING WATER COURSE, DURING CONSTRUCTION ACTIVITIES; THIS INCLUDES LIMITING THE AMOUNT OF EXPOSED SOIL, INSTALLING SILT FENCES AND OTHER EFFECTIVE SEDIMENT TRAPS, AND INSTALLING AND MAINTAINING MUD MATS FOR OUTGOING CONSTRUCTION TRAFFIC DURING CONSTRUCTION ACTIVITIES.
- PREVENT SOIL LOSS DURING CONSTRUCTION (BY STORM WATER RUNOFF OR WIND EROSION).
- PROTECT TOPSOIL BY STOCKPILING FOR REUSE.
- PREVENT SEDIMENTATION OF STORM SEWERS AND RECEIVING STREAMS.
- PREVENT AIR POLLUTION FROM DUST AND PARTICULATE MATTER.
- ALL STORM MANHOLES AND CATCHBASIN MANHOLES TO HAVE 300mm SUMP; ALL CATCHBASINS TO HAVE 600mm SUMP.
- INSTALL FILTER BAG INSERT IN ALL STORM MANHOLES AND CATCH BASINS IMPACTED DURING CONSTRUCTION, INCLUDING CATCH BASINS IN THE RIGHT OF WAY.
- SEDIMENT AND EROSION CONTROL MEASURES MAY BE MODIFIED IN THE FIELD AT THE DISCRETION OF THE CITY OF OTTAWA INSPECTOR OR CONSERVATION AUTHORITY.
- STORM WATER PUMPED INTO CITY SERVICE SHALL FLOW THROUGH A FILTER SOCK.
- THE CONTRACTOR ACKNOWLEDGES THAT FAILURE TO IMPLEMENT APPROPRIATE EROSION AND SEDIMENTATION CONTROL MEASURES MAY BE SUBJECT TO PENALTIES IMPOSED BY ANY APPLICABLE REGULATORY AGENCY.

DRAWING NOTES

- CONNECT NEW WATER SERVICE TO EXISTING 305mm DUCTILE IRON WATERMAIN. APPROXIMATE TOP OF EXISTING WATERMAIN ELEVATION: 67.63. CONTRACTOR TO HYDROVAC TO CONFIRM OBVERT PRIOR TO CONSTRUCTION. WATER CONNECTIONS BY CITY: EXCAVATION, BACKFILLING AND REINSTATEMENT BY THE CONTRACTOR. CONTRACTOR TO COORDINATE WITH CITY OF OTTAWA FORCES.
- SUPPLY AND INSTALL NEW 100mm Ø PVC DR18 WATER MAIN SERVICE. MINIMUM 2.4m COVER. PROVIDE HL40 THERMAL INSULATION IN ACCORDANCE WITH CITY OF OTTAWA STANDARD DETAIL W22 WHERE 2.4m COVER CANNOT BE MET. COORDINATE NEW WATER SERVICE CONNECTION WITH MECHANICAL PLANS.
- SUPPLY AND INSTALL NEW WATERMAIN VERTICAL BENDS AND INSULATION TO CROSS UNDER EXISTING 375mm CONCRETE STORM SEWER IN ACCORDANCE WITH CITY OF OTTAWA STANDARD DETAIL W25.
- CONNECT TO EXISTING 600mm CONCRETE SANITARY SEWER WITH NEW VERTICAL RISER IN ACCORDANCE WITH CITY OF OTTAWA STANDARD DETAIL S11. PROVIDE WATERTIGHT CONNECTION. APPROXIMATE CONNECTION INVERT: 65.52. CONTRACTOR TO CONFIRM EXISTING SANITARY SEWER INVERTS PRIOR TO CONSTRUCTION.
- CONNECT TO EXISTING 375mm CONCRETE STORM SEWER WITH NEW VERTICAL RISE IN ACCORDANCE WITH CITY OF OTTAWA STANDARD DETAIL S11. PROVIDE WATERTIGHT CONNECTION. APPROXIMATE CONNECTION INVERT: 67.80. CONTRACTOR TO CONFIRM MUNICIPAL STORM SEWER INVERTS PRIOR TO CONSTRUCTION.
- CONNECT SERVICES TO INTERIOR PLUMBING 1.0m FROM BUILDING FOUNDATION. PERIMETER FOUNDATION DRAIN TO BE CONNECTED TO NEW STORM SEWER SERVICE. REFER TO MECHANICAL AND ARCHITECTURAL PLANS. CONNECTION ELEVATIONS:
 - STORM INVERT: 68.15
 - SANITARY INVERT: 68.65
 - WATERMAIN OBVERT: 68.00
- SUPPLY AND INSTALL BACKFLOW VALVES ON SANITARY AND STORM BUILDING CONNECTION AS PER CITY OF OTTAWA STANDARD DETAILS S14, AND ONE OF S14.1 OR S14.2.
- INSTALL 3.0m LONG 100mm Ø PERFORATED SUBDRAIN WRAPPED IN GEOTEXTILE SOCK EXTENDING FROM CB/CBMH AT PAVEMENT SUBGRADE LEVEL. PROVIDE WATERTIGHT CONNECTION.
- SUPPLY AND INSTALL WATTS RD-100 FLOW CONTROL ROOF DRAINS. MAXIMUM DISCHARGE 35.8 l/s TOTAL. REFER TO MECHANICAL FOR SPECIFIC WEIR SETTINGS.

Note:
1. Install new clay seals at 50m intervals as per City of Ottawa standard detail S8. Clay seal to be compacted to 95% SPMD

Granular 'A' compacted to 98% SPMD
Min. 300mm bedding
Min. 300mm cover

Approved native material or select subgrade backfill maximum 300mm lifts compacted to 95% SPMD

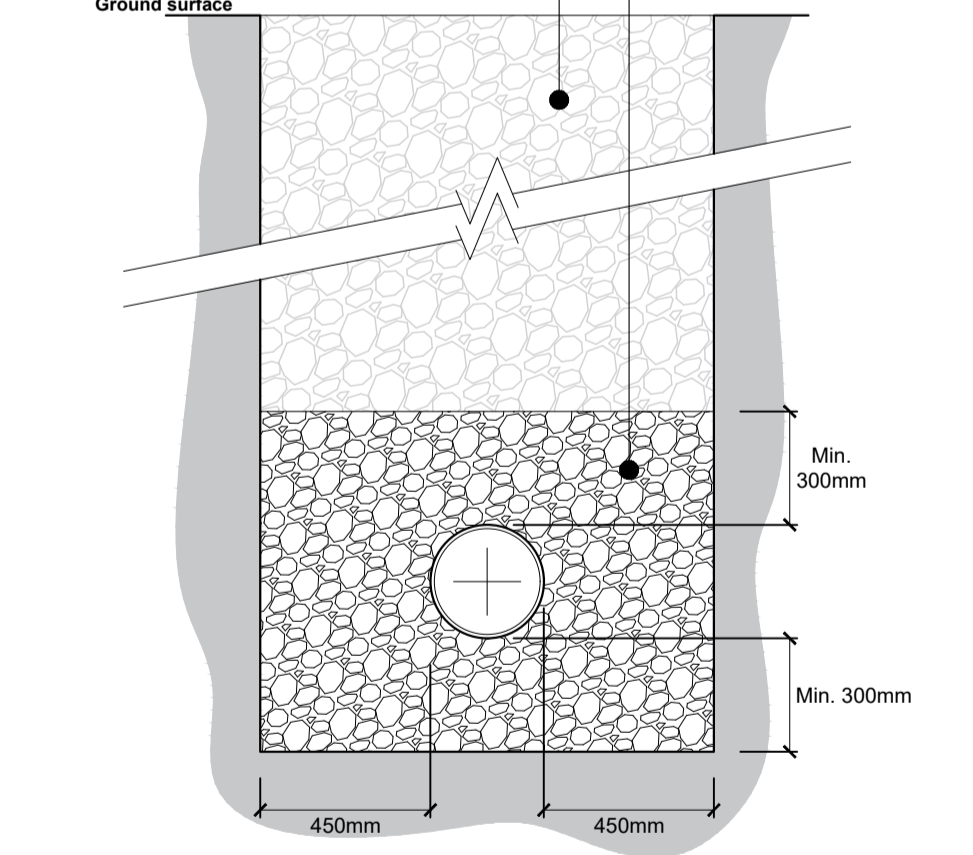

1 Standard Trench Detail
Scale: As shown

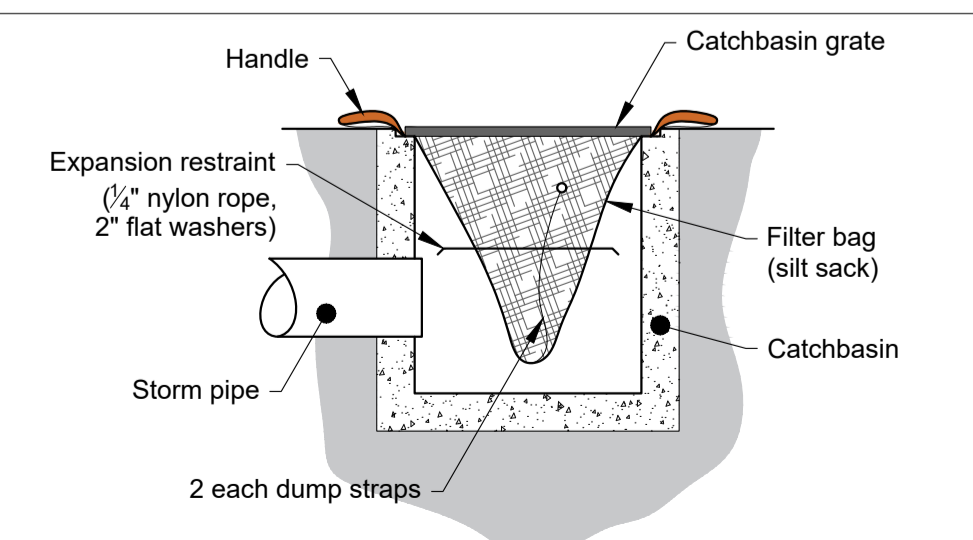

2 Catchbasin Filter Bag / Insert
Scale: Not to scale

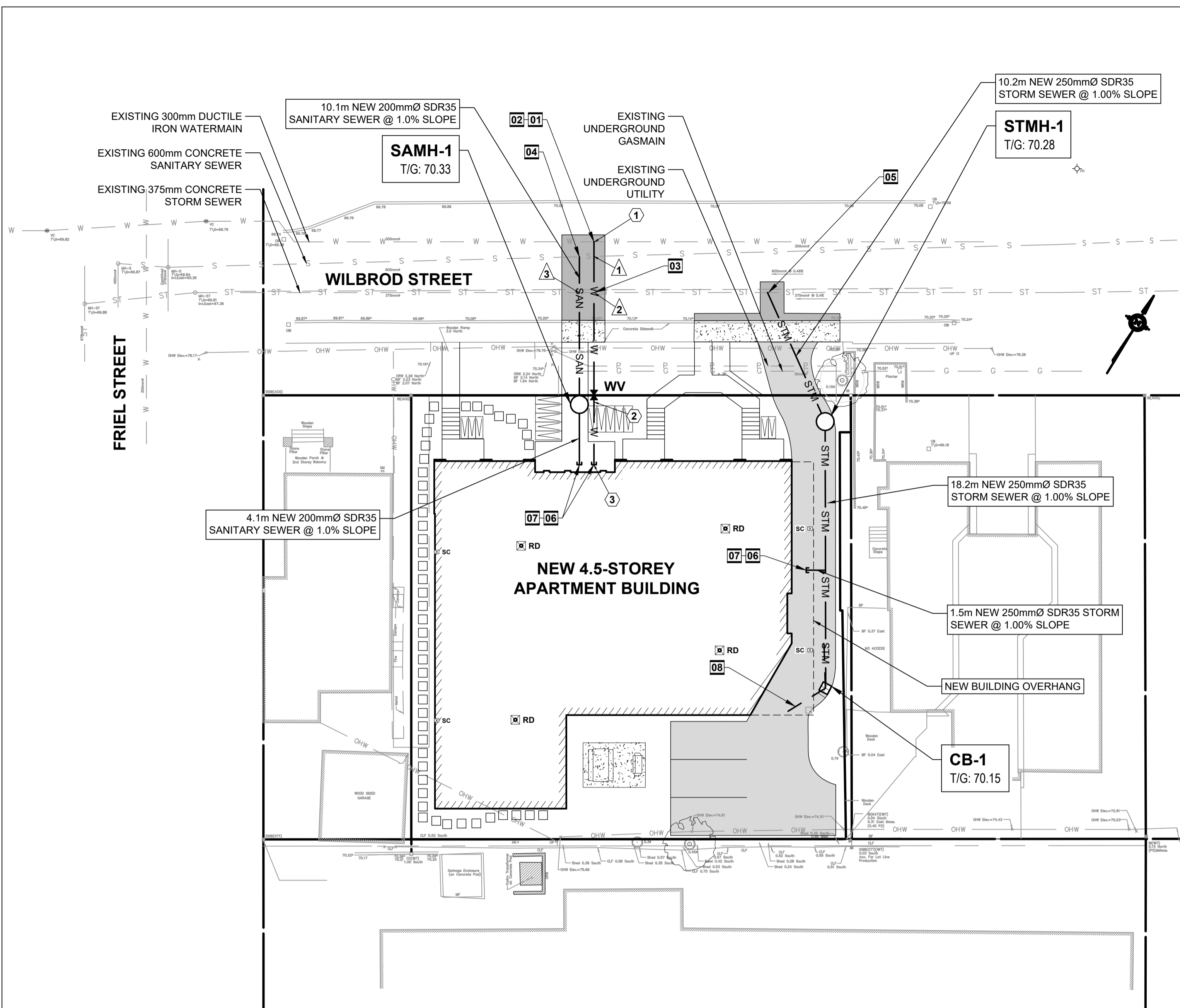

MANHOLE AND CATCHBASIN SCHEDULE

STRUCTURE ID	TOP OF FRAME ELEVATION (m)	PIPE INVERT ELEVATION (m)	STRUCTURE DIAMETER (mm) / OPSD No.	FRAME (OPSD / CITY OF OTTAWA STANDARD)
SAMH-1	70.33	68.61 SW / 68.59 NE	1200 / 701.010	S25 / S24
STMH-1	70.28	68.00 NW / 68.03 SE	1200 / 701.010	S25 / S24.1
CB-1	70.15	68.21 NW	600 x 600 / 705.010	S25 / S19

CROSSING TABLE

LOCATION	OVER / UNDER	INVERT	OBVERT	CLEARANCE (m)
①	NEW WATERMAIN / EXISTING SANITARY SEWER	67.53	65.82	1.71
②	EXISTING STORM SEWER / NEW WATERMAIN	67.70	67.20	0.50
③	NEW SANITARY SEWER / EXISTING STORM SEWER	68.52	68.18	0.34

WATER SERVICE TABLE

ID	DESCRIPTION	FINISHED GRADE (m)	T/O WATERMAIN (m)
①	MUNICIPAL CONNECTION	70.03	67.63
②	VALVE BOX	70.33	67.93
③	BUILDING CONNECTION	70.40	68.00

NOTE: PROVIDE MINIMUM 2.4m COVER OVER T/O WATERMAIN TO FINISHED GRADE. WHERE MINIMUM COVER CANNOT BE MET, PROVIDE THERMAL INSULATION HL40.

Jp2g Consultants Inc.
ENGINEERS • PLANNERS • PROJECT MANAGERS
1150 Morrison Drive, Suite 410, Ottawa, ONT.
Phone: (613) 828-7800 Fax: (613) 828-2600
9929 No.: 21-1062A



No.	DESCRIPTION	DATE
1	SITE PLAN CONTROL	2022-03-09
		YYYY-MM-DD

client

project
WILBROD APT. BUILDING

326-330 WILBROD STREET,
OTTAWA, ON.

seal

drawing title
SITE SERVICING, EROSION AND SEDIMENT CONTROL PLAN

scale	drawn by
As shown	PH
date	checked by
	DN
project number	drawing number
	C1

CONTRACTOR TO VERIFY ALL DIMENSIONS AND NOTIFY THE ARCHITECT OF ANY DISCREPANCIES BEFORE WORK COMMENCES. DO NOT SCALE DRAWINGS.

LEGEND	
	PROPERTY LINE
	EXISTING BUILDING
	EXISTING SANITARY SEWER
	EXISTING STORM SEWER
	EXISTING WATERMAIN
	EXISTING SANITARY MANHOLE
	EXISTING STORM MANHOLE
	EXISTING WATERMAIN VALVE
	EXISTING FIRE HYDRANT
	EXISTING OVERHEAD WIRES
	EXISTING UNDERGROUND UTILITY
	EXISTING UNDERGROUND GASMAIN
	NEW CATCHBASIN
	NEW CATCHBASIN MANHOLE
	NEW SANITARY MANHOLE
	NEW STORM MANHOLE
	NEW WATER VALVE
	NEW INLET CONTROL DEVICE
	NEW ROOF DRAIN
	NEW SCUPPER
	NEW ASPHALT
	NEW CONCRETE SIDEWALK
	NEW GRADE
	NEW SLOPE

DRAWING NOTES	
01	MATCH EXISTING GRADES AT PROPERTY LINE AND LIMITS OF WORK.
02	NEW BARRIER CURB AS PER CITY OF OTTAWA STANDARD DETAIL SC1.1.
03	PROTECT EXISTING CONCRETE SIDEWALK DURING CONSTRUCTION.
04	NEW CONCRETE SIDEWALK COMPLETE WITH REINFORCING MESH 150mm X 150mm, MW9.1 X MW9.1 COMPLETE WITH EXPANSION JOINT PER CITY OF OTTAWA STANDARD DETAIL SC5.

GENERAL NOTES	
1.	DESIGN AND CONSTRUCTION IS TO BE IN ACCORDANCE WITH MOST RECENT ONTARIO BUILDING CODE.
2.	THE CONTRACTOR IS RESPONSIBLE FOR CHECKING AND VERIFYING ALL DIMENSIONS WITH RESPECT TO SITE CONDITIONS AND ALL MATERIALS TO THE PROJECT. ANY DISCREPANCY SHALL BE REPORTED TO THE ENGINEER.
3.	THIS DRAWING IS TO BE READ IN CONJUNCTION WITH ALL MATERIAL RELEVANT TO THE PROJECT.
4.	ADDITIONAL DRAWINGS MAY BE ISSUED FOR CLARIFICATION TO ASSIST PROPER EXECUTION OF WORK. SUCH DRAWINGS WILL HAVE THE SAME MEANING AND INTENT AS IF THEY WERE INCLUDED WITH THE CONTRACT DOCUMENTS.
5.	CONTRACTOR MUST COMPLY WITH LOCAL BY-LAWS, ONTARIO OCCUPATIONAL HEALTH AND SAFETY ACT AND ALL REGULATIONS SET BY AUTHORITIES HAVING JURISDICTION. IN CASE OF CONFLICT OR DISCREPANCY, THE MORE STRINGENT REQUIREMENTS SHALL APPLY.
6.	CONTRACTOR RESPONSIBLE FOR OBTAINING ALL REQUIRED UTILITY LOCATES, DAYLIGHTING, INSPECTIONS, PERMITS, AND APPROVALS, INCLUDING ALL ASSOCIATED COSTS. LOCATION OF EXISTING UTILITIES ARE APPROXIMATE ONLY AND BASED ON BEST AVAILABLE INFORMATION.

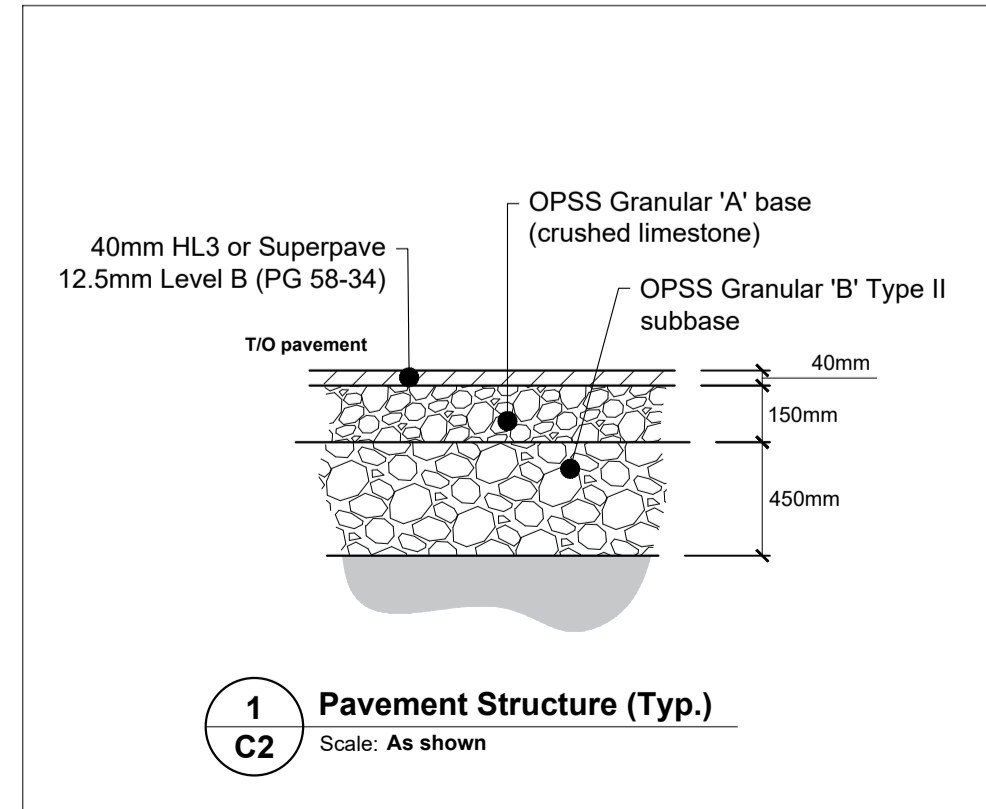
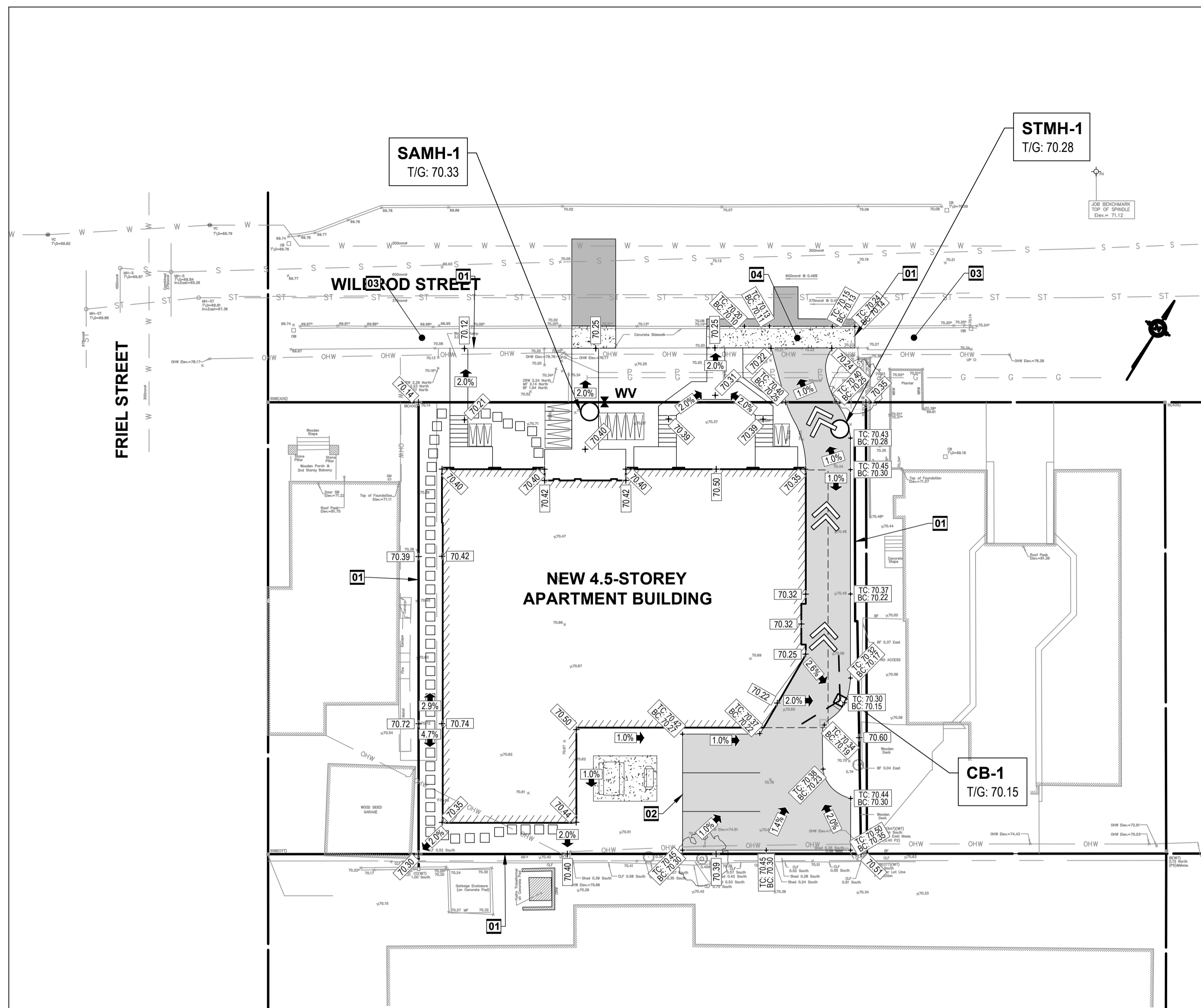

Jp2g Consultants Inc.
ENGINEERS • PLANNERS • PROJECT MANAGERS
1150 Morrison Drive, Suite 410, Ottawa, ONT.
Phone: (613) 828-7800 Fax: (613) 828-2600
Jp2g No.: 21-1062A



No.	DESCRIPTION	DATE
1	SITE PLAN CONTROL	2022-03-09
		YYYY-MM-DD

client

project
WILBROD APT. BUILDING

326-330 WILBROD STREET,
OTTAWA, ON.

seal

drawing title	
GRADING AND DRAINAGE PLAN	
scale As shown	drawn by PH
date	checked by DN
project number	drawing number C2
CONTRACTOR TO VERIFY ALL DIMENSIONS AND NOTIFY THE ARCHITECT OF ANY DISCREPANCIES BEFORE WORK COMMENCES. DO NOT SCALE DRAWINGS.	
	revision



Appendix B - Stormwater Management Calculations

Appendix B - Storm Sewer Design Sheet

B.1.1 - Allowable release rate

ID	Description	Type	Areas (m ²)		Total (m ²)	C _{pre-5-yr}	C _{pre-100-yr} *
			C _{0.90}	C _{0.20}			
A	Property Grounds	uncontrolled	807	90	897	0.83	0.92
			807	90	897	0.83	0.92

*including 25% increase as per City of Ottawa Sewer Design Guidelines

Calculations for post-development runoff coefficient

$$C_{\text{post-5-yr (col. D)}} = (\text{column A} * 0.9 + \text{column B} * 0.2) / \text{column C}$$

$$C_{\text{post-100-yr (col. E)}} = (\text{column A} * 1.0 + \text{column B} * 0.2 * 1.25) / \text{column C}$$

Note: 0.90 x 1.25 = 1.125, use max. 1.0

Calculations for average weighted runoff coefficient

$$C_{\text{post-5-yr}} = ((6279 * 0.9) + (6538 * 0.2)) / 12817 = 0.75$$

$$C_{\text{post-100-yr}} = ((6279 * 1.0) + (6538 * 0.2 * 1.25)) / 12817 = 0.84$$

Estimated time of concentration, t_c =

10.0 minutes *****As per City of Ottawa Sewer Design Guidelines (Section 5.4.5.2)**

Based on Ottawa IDF curve, i_{5-years} =

$$998.071 / (t_c + 6.053)^{0.814}$$

104.2 mm/hr

Based on Ottawa IDF curve, i_{100-years} =

$$1735.688 / (t_c + 6.014)^{0.820}$$

178.6 mm/hr

Using the Rational Method, the maximum allowable release rate is therefore:

Total Area, A = **0.09** ha
 5-year Runoff coefficient, C = **0.90**
 Estimated time of concentration, t_c = **10.0** minutes
 Based on Ottawa IDF curve, i_{5-years} = **104.2** mm/hr

$$Q_{\text{allowable}} = 2.78 C \times i \times A$$

$$Q_{\text{allowable (5-year)}} = **23.4** \text{ l/s} \quad \textcircled{1}$$

100-year Runoff coefficient, C = **1.00**
 Estimated time of concentration, t_c = **10.0** minutes
 Based on Ottawa IDF curve, i_{100-years} = **178.6** mm/hr

$$Q_{\text{allowable}} = 2.78 C \times i \times A$$

$$Q_{\text{allowable (100-year)}} = **44.5** \text{ l/s}$$

B.1.2 - Post-development release rate

ID	Description	Type	Areas (m ²)		Total (m ²)	C _{post-5-yr}	C _{post-100-yr} *
			C _{0.90}	C _{0.20}			
B1	Building Roof	controlled	466	4	470	0.89	0.99
B2	Parking Lot and Side Access	uncontrolled	144	83	227	0.64	0.73
B3	North and West Property Frontage	uncontrolled	92	108	200	0.52	0.60
			702	195	897	0.75	0.84

*including 25% increase as per City of Ottawa Sewer Design Guidelines

(A) (B) (C) (D) (E)

B.1.2.1 - Uncontrolled overland surface flow

Total uncontrolled area **0.043** ha
 5-year Runoff coefficient **0.59**
 100-year Runoff coefficient **0.66**

Uncontrolled Release Rate 5-year **7.3** l/s $\textcircled{2}$
 Uncontrolled Release Rate 100-year **14.1** l/s $\textcircled{4}$

B.1.2.2 - Net-allowable release rate for storm sewers

$Q_{\text{net-allowable 5-year}} = 16.1$ l/s ③ = ①-②
 $*Q_{\text{net-allowable 100-year}} = 9.3$ l/s ⑤ = ①-④ * Must be controlled to net-allowable 100-year

B.1.3 - Post-development onsite storage

B.1.3.1 - Estimated Roof detention

Total controlled area **0.047** ha
 5-year Runoff coefficient **0.89**
 100-year Runoff coefficient **0.99**
 Release rate **9.3** l/s

Table 1.3.1a - 5-year estimated detention

	Time (minutes)	$i_{5\text{-years}}$ (mm/hr)	Q_{actual} (l/s)	$Q_{\text{allowable}}$ (l/s)	Q_{stored} (l/s)	V_{stored} (m ³)
<i>peak V_{stored}</i> →	10	104.2	12.2	9.3	2.9	1.7
	15	83.6	9.8	9.3	0.5	0.4
	20	70.3	8.2	9.3	-1.1	-1.3
	25	60.9	7.1	9.3	-2.2	-3.3
	30	53.9	6.3	9.3	-3.0	-5.4
	35	48.5	5.7	9.3	-3.6	-7.6
	40	44.2	5.2	9.3	-4.1	-9.9
	45	40.6	4.7	9.3	-4.6	-12.3
	50	37.7	4.4	9.3	-4.9	-14.7
	55	35.1	4.1	9.3	-5.2	-17.1
	60	32.9	3.8	9.3	-5.5	-19.6

Therefore **2** m³ estimated detention

Table 1.3.1b - 100-year estimated detention

	Time (min)	$i_{100\text{-years}}$ (mm/hr)	Q_{actual} (l/s)	$Q_{\text{allowable}}$ (l/s)	Q_{stored} (l/s)	V_{stored} (m ³)
<i>peak V_{stored}</i> →	10	178.6	23.2	9.3	13.9	8.3
	15	142.9	18.6	9.3	9.3	8.3
	20	120.0	15.6	9.3	6.3	7.5
	25	103.8	13.5	9.3	4.2	6.3
	30	91.9	11.9	9.3	2.6	4.7
	35	82.6	10.7	9.3	1.4	3.0
	40	75.1	9.8	9.3	0.5	1.1
	45	69.1	9.0	9.3	-0.3	-0.9
	50	64.0	8.3	9.3	-1.0	-3.0
	55	59.6	7.7	9.3	-1.6	-5.1
	60	55.9	7.3	9.3	-2.0	-7.4

Therefore **8** m³ estimated detention

B.1.4 - Site storage

	5-year required (m3)	100-year required (m3)	Ponding depth (m)	Ponding area (m2)	Max available (m3)
Roof Detention	2	8	0.15	470	24

STORM SEWER DESIGN SHEET

LOCATION				CONTRIBUTING AREA									FLOW				STORM SEWER DESIGN										
1	2	3	4	5	6	7	8	9	10	11	12	13	14	15	16	17	18	19	20	21	22	23	24	29	30	31	32
Note	FROM	TO	AREA ID	SEWER TYPE (Lateral or Trunk)	HARD AREA (A1) (ha)	HARD RUNOFF COEFF. (C1) (-)	SOFT AREA (A2) (ha)	SOFT RUNOFF COEFF. (C2) (-)	TOTAL AREA (A3) (ha)	WEIGHTED RUNOFF COEFF. (C3) (-)	SECTION (A3*C3) (ha)	ACC. SECTION (ha)	TIME OF CONCEN. (Tc) (min)	RAINFALL INTENSITY 5-YR (I) (mm/hr)	RAINFALL INTENSITY 100-YR (I) (mm/hr)	FLOW 5-YR (L/s)	FLOW 100-YR (L/s)	LENGTH (m)	SLOPE (%)	DIA. (mm)	FULL FLOW CAPACITY (L/s)	FULL FLOW vs. ACTUAL FLOW (L/s)	FULL FLOW VELOCITY (m/s)	TIME OF FLOW IN PIPE (min)	TIME OF CONCEN AFT. PIPE (min)	FALL IN PIPE SECTION (m)	COMMENTS
Parking Lot	CB-1	STMH-1	B2	Trunk	0.01	0.90	0.01	0.20	0.02	0.64	0.015	0.015	10.00	104.193	178.559	4.23	7.26	18.2	1.00%	200	32.80	13%	1.04	0.29	10.29	0.18	
School Roof	Roof	Lateral Con.	B1	Lateral	0.05	0.90	0.00	0.20	0.05	0.89	0.042	0.057	10.00	104.193	178.559	12.17	28.12	1.5	1.00%	200	32.80	37%	1.04	0.02	10.02	0.02	
Municipal Connection	STMH-1	Municipal Con.		Trunk	0.01	0.90	0.01	0.20	0.02	0.52	0.010	0.067	10.29	102.683	175.946	2.98	32.81	10.2	1.00%	200	32.80	9%	1.04	0.16	10.45	0.10	

Notes:
Rainfall Data Source: Ottawa CDA RCS 5 Year
Mannings, n = 0.013

Designed By: P.H.
Checked By: D.N.



Appendix C - Sanitary Servicing Calculations

Appendix C - Sanitary Sewer Design Sheet

Definitions

Manning's Coefficient (n) = 0.013

Manning's Formula

$Q = A \cdot R^{2/3} \cdot S^{1/2} / n$ (l/s), where
A = Areas in Hectares (ha)
R = Hydraulic Radius (m)
S = Slope

Design Parameters*

- 1) Average Daily Flow = 280 L/p/day
- 2) Commercial/Institutional Flow = 28,000 L/ha/day
- 3) Maximum Residential Peak Factor = 4
- 4) Commercial/Institutional Peak Factor = 1.50
- 5) Extraneous Flow = 0.33L/s/ha
- 6) Minimum Velocity = 0.76 m/s

C.1.1 - Pre-Development Flow

Location			Residential Flow							Commercial Flow			Infiltration Flow			Total Flow	
Note	From	To	Area (ha)	Units	Population	Cumulative		Average Flow (l/s)	Peak Flow (l/s)	Area (ha)		Peak Flow (l/s)	Area (ha)		Inf. Flow (l/s)	Average Flow (l/s)	Peak Flow (l/s)
						Area	Population			Individual	Cumulative		Individual	Cumulative			
Existing Buildings	Ex.	Municipal Con.	0.03	1	4	0.03	4	0.01	0.05	0.060	0.060	0.03	0.09	0.09	0.03	0.07	0.11

C.1.2 - Post Development Flow

Location			Residential Flow							Infiltration Flow			Total Flow		Sewer Data			
Note	From	To	Area (ha)	Units	Population	Cumulative		Average Flow (l/s)	Peak Flow (l/s)	Area (ha)		Inf. Flow (l/s)	Average Flow (l/s)	Peak Flow (l/s)	Dia. (mm)	Slope	Capacity (full) (l/s)	Utilization (%)
						Area	Population			Individual	Cumulative							
Apartment	Apartment	SAMH-1	0.09	40	72	0.09	75	0.24	0.97	0.09	0.09	0.03	0.27	1.00	200	1.00%	32.8	3.1
Municipal Connection	SAMH-1	Municipal Con.	0.09	0	72	0.09	75	0.24	0.97	0.09	0.09	0.03	0.27	1.00	200	1.00%	32.8	3.1

* City of Ottawa Sewer Design Guidelines, Section 4 - Sanitary Sewer Systems



Appendix D - Fire Flow Demand Calculations

New Wilbrod Apartment Complex



Appendix D- Fire Flow Demand Requirements

D.1.1 - Fire Flow Demand Requirements (Fire Underwriters Survey (FUS Guidelines))

Fire Flow Formula

Estimated Fire Flow Formula: $F=220 \cdot C \cdot A^{1/2}$ (L/min)

- F = Required fire flow (L/min)
- C = Coefficient related to the type of construction
- C_{1.5} = 1.5 for wood frame construction
- C_{1.0} = 1.0 for ordinary construction
- C_{0.8} = 0.8 for non-combustible construction
- C_{0.6} = 0.6 for fire-resistive construction
- A = Total floor area in square metres

Designed PH
Checked DN

New School Building

Design Parameters*

- Type of Building Construction = Non-combustible construction
- Floor Area*** = 470.0 m²
- Occupancy Class = Limited combustible
- Sprinkler System = Automatic sprinkler system conforming to NFPA standards with standard water supply and full supervision
- Sprinkler Building Coverage = Complete building coverage
- Factor of Building Coverage X =
- Number of Storeys = 4

Exposure Parameters*

	North	East	South	West	
Separation Distance =	25.0	6.2	8.2	2.8	m
Length of Exposed Wall =	24.5	12.4	8.8	15	m
Length-Height Factor =	98.0	24.8	26.4	37.5	m-storeys (up to a maximum of 5-storeys)

Building Construction	Floor Area*** (m ²)	Coefficient	Adjustments (increases or decreases)										Final Adjusted Fire Flow	Final Adjusted Fire Flow	
			A		B = A +/- %		C = B x %		D = B x %						
			Fire Flow (F) (L/min)	Occupancy	Adjusted Fire Flow(s) (L/min)	Sprinkler	Exposure***				E = B - C + D (L/min)**	(L/s)			
Non-combustible construction	1,880.0	0.8	8,000.0	-0.15	6,800.0	50%	3,400.0	9%	17%	17%	23%	66%	4,488.0	8,000.0	133.3

*Water Supply for Public Protection (Fire Underwriters Survey, 1999).

***Including all stories



Appendix E - Pre-Consultation & Development Servicing Study Checklist

APPLICANT'S STUDY AND PLAN IDENTIFICATION LIST

Legend: **S** indicates that the study or plan is required with application submission.

A indicates that the study or plan may be required to satisfy a condition of approval/draft approval.

For information and guidance on preparing required studies and plans refer [here](#):

S/A	Number of copies	ENGINEERING		S/A	Number of copies
S	15	1. Site Servicing Plan	2. Site Servicing Study / Assessment of Adequacy of Public Services	<input type="checkbox"/>	3
S	15	3. Grade Control and Drainage Plan	4. Geotechnical Study / Slope Stability Study	S	3
<input type="checkbox"/>	2	5. Composite Utility Plan	6. Groundwater Impact Study	<input type="checkbox"/>	3
S	3	7. Servicing Options Report	8. Wellhead Protection Study	<input type="checkbox"/>	3
<input type="checkbox"/>	9	9. Transportation Impact Assessment (TIA)	10. Erosion and Sediment Control Plan / Brief	S	3
S	3	11. Storm water Management Report / Brief	12. Hydro geological and Terrain Analysis	<input type="checkbox"/>	3
<input type="checkbox"/>	3	13. Hydraulic Water main Analysis	14. Noise / Vibration Study	<input type="checkbox"/>	3
<input type="checkbox"/>	PDF only	15. Roadway Modification Functional Design	16. Confederation Line Proximity Study	<input type="checkbox"/>	3

S/A	Number of copies	PLANNING / DESIGN / SURVEY		S/A	Number of copies
<input type="checkbox"/>	15	17. Draft Plan of Subdivision	18. Plan Showing Layout of Parking Garage	<input type="checkbox"/>	2
<input type="checkbox"/>	5	19. Draft Plan of Condominium	20. Planning Rationale	S	3
S	15	21. Site Plan	22. Minimum Distance Separation (MDS)	<input type="checkbox"/>	3
S	15	23. Concept Plan Showing Proposed Land Uses and Landscaping	24. Agrology and Soil Capability Study	S	3
<input type="checkbox"/>	3	25. Concept Plan Showing Ultimate Use of Land	26. Cultural Heritage Impact Statement	<input type="checkbox"/>	3
S	15	27. Landscape Plan	28. Archaeological Resource Assessment Requirements: S (site plan) A (subdivision, condo)	<input type="checkbox"/>	3
S	2	29. Survey Plan	30. Shadow Analysis	<input type="checkbox"/>	3
S	3	31. Architectural Building Elevation Drawings (dimensioned)	32. Design Brief (includes the Design Review Panel Submission Requirements)	S	Available online
<input type="checkbox"/>	3	33. Wind Analysis		<input type="checkbox"/>	

S/A	Number of copies	ENVIRONMENTAL		S/A	Number of copies
S	3	34. Phase 1 Environmental Site Assessment	35. Impact Assessment of Adjacent Waste Disposal/Former Landfill Site	<input type="checkbox"/>	3
S	3	36. Phase 2 Environmental Site Assessment (depends on the outcome of Phase 1)	37. Assessment of Landform Features	<input type="checkbox"/>	3
<input type="checkbox"/>	3	38. Record of Site Condition	39. Mineral Resource Impact Assessment	<input type="checkbox"/>	3
S	3	40. Tree Conservation Report	41. Environmental Impact Statement / Impact Assessment of Endangered Species	<input type="checkbox"/>	3
<input type="checkbox"/>	3	42. Mine Hazard Study / Abandoned Pit or Quarry Study	43. Integrated Environmental Review (Draft, as part of Planning Rationale)	<input type="checkbox"/>	3

S/A	Number of copies	ADDITIONAL REQUIREMENTS		S/A	Number of copies
	1	44. Applicant's Public Consultation Strategy (may be provided as part of the Planning Rationale)	45. Site Lighting Plan	<input type="checkbox"/>	3
	1	46. Site Lighting Certification Letter	47.		

Meeting Date: November 22, 2021

Application Type: *Site Plan Control, Zoning*

File Lead (Assigned Planner): Jessica Button

Infrastructure Approvals Project Manager: John Wu

Site Address (Municipal Address): 326 Wilbrod

*Preliminary Assessment: 1 2 3 4 5

*One (1) indicates that considerable major revisions are required before a planning application is submitted, while five (5) suggests that proposal appears to meet the City's key land use policies and guidelines. **This assessment is purely advisory and does not consider technical aspects of the proposal or in any way guarantee application approval.**

It is important to note that the need for additional studies and plans may result during application review. If following the submission of your application, it is determined that material that is not identified in this checklist is required to achieve complete application status, in accordance with the Planning Act and Official Plan requirements, the Planning, Infrastructure and Economic Development Department will notify you of outstanding material required within the required 30 day period. Mandatory pre-application consultation will not shorten the City's standard processing timelines, or guarantee that an application will be approved. It is intended to help educate and inform the applicant about submission requirements as well as municipal processes, policies, and key issues in advance of submitting a formal development application. This list is valid for one year following the meeting date. If the application is not submitted within this timeframe the applicant must again pre-consult with the Planning, Infrastructure and Economic Development Department.

Description:

A Design Brief is the core submission document that illustrates how the development is designed to work with its existing and planned context, to improve its surroundings and also demonstrate how the proposal supports the overall goals of the Official Plan, relevant secondary plans, Council approved plans and design guidelines. The purpose of the Terms of Reference is to assist the applicant to organize and substantiate the design justification in support of the proposed development and to assist staff and the public in the review of the proposal.

Authority to Request a Design Brief:

The *Planning Act* gives municipalities the authority to require that a Design Brief be prepared. Under Sections 22(4), (5) and Section 41(4) of the *Planning Act*, a Council has the authority to request such other information or material that the authority needs in order to evaluate and make a decision on an application. Section 5.2.6 of the Official Plan sets out the general requirement for a Design Brief.

Preparation:

The Design Brief should be signed by an urban designer, licenced architect, landscape architect, or a full member of the Canadian Institute of Planners.

When Required:

A Design Brief is required for a Site Plan Control planning application.

A Scoped Design Brief* is required when the following planning applications are applied for and not accompanied by a Site Plan Control application:

- Official Plan Amendment
- Zoning By-law Amendment (exception: a change in use which does not result in an increase in height or massing)

The requirement and scope of a Design Brief will be determined at the formal pre-application consultation meeting. Should an application be required to go to the [Urban Design Review Panel \(UDRP\)](#), the Design Brief may be submitted as part of the submission materials to the panel.

Contents for Design Brief Submissions:

A Design Brief will contain and/or address the points identified during the pre-consultation meeting. Failure to address the critical elements identified in the pre-consultation meeting may result in the application being considered incomplete.

* A *Scoped Design Brief* is composed of:

- Section 1 should be combined into the *Planning Rationale* submission, and
- Section 2 items will be confirmed in the pre-application consultation meeting.

SECTION 1 Note: This section can be combined with the Planning Rationale.

Application Submission:

Not Required

Required

State the: type of application, legal description, municipal address, purpose of the application and provide an overall vision statement and goals for the proposal.

Response to City Documents:

Not Required

Required

State the Official Plan land use designation for the subject property and demonstrate how the proposal conforms to the Official Plan as it relates to the design of the subject site. Reference specific policy numbers from the Official Plan to show consistency. Justify areas of non-compliance and explain why there is non-compliance.

State the applicable plans which apply to the subject proposal: community design plan, secondary plan, concept plan and design guideline. Reference the relevant design related policies within the applicable plans/guidelines and provide a comprehensive analysis as to how the proposed development incorporates the objectives or why it does not incorporate the objectives.

Context Plan:

Not Required

Required

Provide a contextual analysis that discusses/illustrates abutting properties, key destinations and linkages within a 100 meter radius (a larger radius may be requested for larger/more complex projects), such as transit stations, transportation networks for cars, cyclists, and pedestrians, focal points/nodes, gateways; parks/open spaces, topography, views towards the site, the urban pattern (streets, blocks), future and current proposals (if applicable), public art and heritage resources.

Photographs to illustrate existing site conditions and surrounding contexts. Include a map pinpointing (with numbers) where each photo is taken and correspond these numbers with the site photos. Arrows illustrating the direction the photo is taken is also useful.

SECTION 2

TO BE CONSOLIDATED INTO COMBINED PLANNING RATIONALE and DESIGN BRIEF

Design Proposal:

The purpose of the Design Proposal is to show the building elevations, exterior details, transitions in form, treatment of the public realm and compatibility with adjacent buildings, using 3-D models, illustrations, diagrams, plans, and cross sections. Referencing Official Plan, Section 5.2.1, as determined at time of pre-application consultation meeting, submissions will need to address the following in the form of labelled graphics and written explanation:

Massing and Scale

Not Required Required

- | | | |
|---|---|---|
| <input type="checkbox"/>

<input type="checkbox"/>

<input type="checkbox"/>

<input type="checkbox"/>

<input checked="" type="checkbox"/>

<input type="checkbox"/> | <input type="checkbox"/>

<input checked="" type="checkbox"/>

<input type="checkbox"/>

<input checked="" type="checkbox"/>

<input type="checkbox"/>

<input checked="" type="checkbox"/> | <p><i>Images which show:</i>
 <u>Building massing</u> – from:</p> <ul style="list-style-type: none"> • at least two sides set within its current context (showing the entire height and width of the building) OR • all four sides set within its current context (showing the entire height and width of the building). <p><u>Views</u> – of the entire block, from:</p> <ul style="list-style-type: none"> • at least two perspectives to show how the proposed building is set within its current context OR • all four perspectives to show how the proposed building is set within its current context. <p><u>Building transition</u> – to adjacent uses, with labelled explanation of the transition measures used.</p> <p><u>Grading</u> – if grades are an issue.</p> <p><u>Alternative building massing</u> – additional imagery and site layouts considered and provide justification for the ultimate proposal sought.</p> |
|---|---|---|

Public Realm

Not Required Required

- | | | |
|---|---|---|
| <input checked="" type="checkbox"/>

<input type="checkbox"/> | <input type="checkbox"/>

<input checked="" type="checkbox"/> | <p><i>Labelled graphics and a written explanation which show:</i>
 <u>Streetscape</u> – cross sections which illustrate the street design and right of way (referencing the City’s design manuals).</p> <p><u>Relationship to the public realm</u> – illustrating how the first few storeys of the proposed development responds to and relates to the existing context (e.g. through a podium plan and first floor plan). This is to include detailed explanation on:</p> <ul style="list-style-type: none"> • Architectural responses • Landscaping details • Public art features (in accordance with Official Plan, Section 4.11) • For developments in Design Priority Areas, detail the building and site features, (in accordance with Official Plan, Section 4.11) which will enhance the public realm. Provide explanation for features which are not provided. |
|---|---|---|

Building Design

Not Required

Required

Labelled graphics (e.g. building elevations and floor plans) and a written explanation which document the proposed exterior architectural details and design (in accordance with Official Plan, Section 5.2.1).

Low-Rise Proposed

For high-rise development applications, detail the building design and massing and scale elements and how they relate to the proposed high-rise development (in accordance with Official Plan, Section 5.2.1).

Sustainability

Not Required

Required

Any sustainable design features to be incorporated, such as green roofs or walls, sun traps, reflective or permeable surfaces.

Heritage

Not Required

Required

How the building relates to the historic details, materials, site and setting of any existing historic resources on or adjacent to the subject property (if applicable).

Additional Contents:

Some proponents may be requested to provide submission material which complements the Design Brief. These additional requirements could be incorporated into the Design Brief submission for ease of review. These will be identified at the time of application consultation meeting:

- X • Site Plan
- X • Landscape Plan
- Plan showing existing and proposed servicing
- Shadow Analysis
- Wind Analysis

Submission Requirements

- Six hard copies and one digital copy



Appendix F - Roof Drain Product Data Sheet

PRODUCT TECHNICAL SPECIFICATION

General

Inlet control devices (ICD's) are designed to provide flow control at a specified rate for a given water head level and also provide odour and floatable control. All ICD's will be IPEX Tempest or approved equal.

All devices shall be removable from a universal mounting plate. An operator from street level using only a T-bar with a hook will be able to retrieve the device while leaving the universal mounting plate secured to the catch basin wall face. The removal of the TEMPEST devices listed above must not require any unbolting or special manipulation or any special tools.

High Flow (HF) Sump devices will consist of a removable threaded cap which can be accessible from street level with out entry into the catchbasin (CB). The removal of the threaded cap shall not require any special tools other than the operator's hand.

ICD's shall have no moving parts.

Materials

ICD's are to be manufactured from Polyvinyl Chloride (PVC) or Polyurethane material, designed to be durable enough to withstand multiple freeze-thaw cycles and exposure to harsh elements.

The inner ring seal will be manufactured using a Buna or Nitrile material with hardness between Duro 50 and Duro 70.

The wall seal is to be comprised of a 3/8" thick Neoprene Closed Cell Sponge gasket which is attached to the back of the wall plate.

All hardware will be made from 304 stainless steel.

Dimensioning

The Low Medium Flow (LMF), High Flow (HF) and the High Flow (HF) Sump shall allow for a minimum outlet pipe diameter of 200mm with a 600mm deep Catch Basin sump.

Installation

Contractor shall be responsible for securing, supporting and connecting the ICD's to the existing influent pipe and catchbasin/manhole structure as specified and designed by the Engineer.

PRODUCT INFORMATION: TEMPEST HF & MHF ICD

Product Description

Our HF, HF Sump and MHF ICD's are designed to accommodate catch basins or manholes with sewer outlet pipes 6" in diameter or larger. Any storm sewer larger than 12" may require custom modification. However, IPEX can custom build a TEMPEST device to accommodate virtually any storm sewer size.

Available in 5 preset flow curves, these ICDs have the ability to provide constant flow rates: 9lps (143 gpm) and greater

Product Function

TEMPEST HF (High Flow): designed to manage moderate to higher flows 15 L/s (240 gpm) or greater and prevent the propagation of odour and floatables. With this device, the cross-sectional area of the device is larger than the orifice diameter and has been designed to limit head losses. The HF ICD can also be ordered without flow control when only odour and floatable control is required.



TEMPEST HF (High Flow) Sump: The height of a sewer outlet pipe in a catch basin is not always conveniently located. At times it may be located very close to the catch basin floor, not providing enough sump for one of the other TEMPEST ICDs with universal back plate to be installed. In these applications, the HF Sump is offered. The HF Sump offers the same features and benefits as the HF ICD; however, is designed to raise the outlet in a square or round catch basin structure. When installed, the HF sump is fixed in place and not easily removed. Any required service to the device is performed through a clean-out located in the top of the device which can be often accessed from ground level.

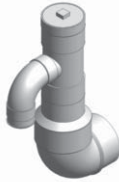

TEMPEST MHF (Medium to High Flow):

The MHF plate or plug is designed to control flow rates 9 L/s (143 gpm) or greater. It is not designed to prevent the propagation of odour and floatables.



Product Construction

The HF, HF Sump and MHF ICDs are built to be light weight at a maximum weight of 6.8 Kg (14.6 lbs).

Product Applications

The HF and MHF ICD's are available to accommodate both square and round applications:



Square Application

Universal Mounting Plate

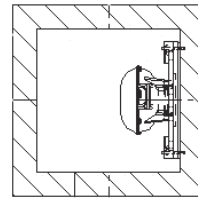

Round Application

Spigot CB Wall Plate



Universal Mounting Plate Hub Adapter



+

=

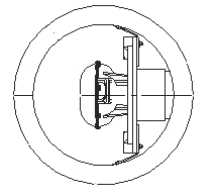
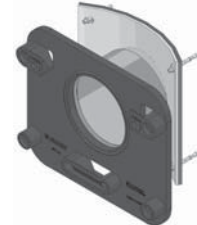

The HF Sump is available to accommodate low to no sump applications in both square and round catch basins:

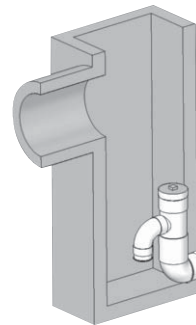

Square Catch Basin

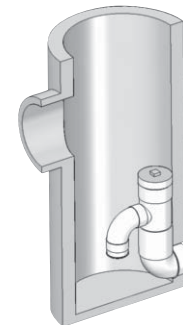

Round Catch Basin

Chart 3: HF & MHF Preset Flow Curves

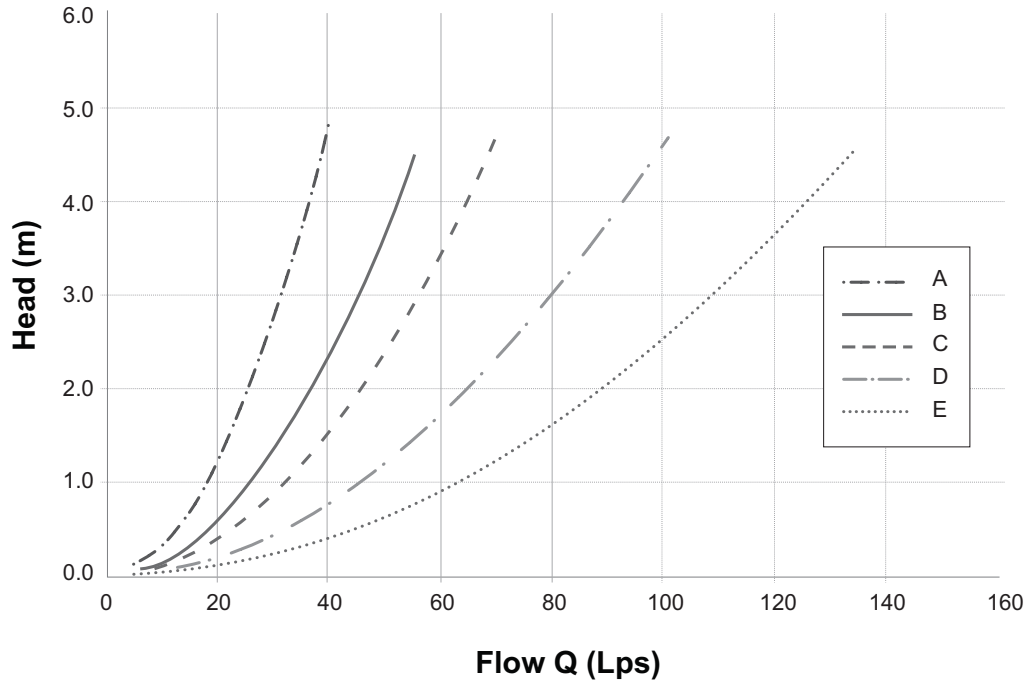

TEMPEST
 HF & MHF ICD



RD-100

Tag: _____

Large Capacity Roof Drain

Components:



SPECIFICATION: Watts Drainage Products RD-100 epoxy coated cast iron roof drain with deep sump, wide serrated flashing flange, flashing clamp device with integral gravel stop and self-locking polyethylene (standard) dome strainer.

Order Code: RD-10 - -

Ex. RD-102P-K

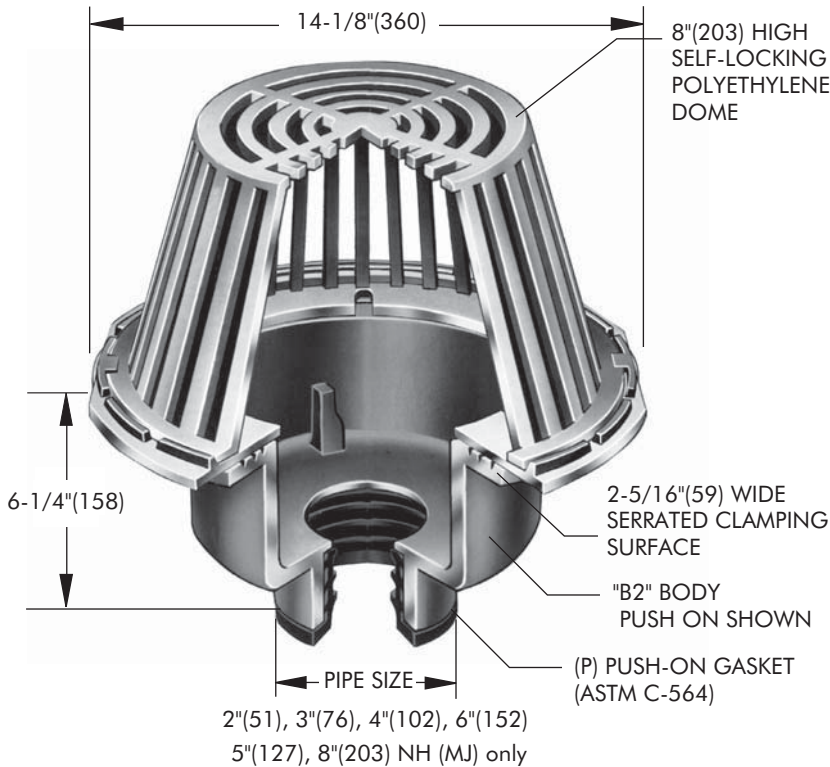

Free Area Sq. In.
137

Deck opening 10" (254)
with sump receiver 13-1/4" (337)

Pipe Sizing (Select One)		
Suffix	Description	
2	2"(51) Pipe Size	<input type="checkbox"/>
3	3"(76) Pipe Size	<input type="checkbox"/>
4	4"(102) Pipe Size	<input type="checkbox"/>
5	5"(127) Pipe Size	<input type="checkbox"/>
6	6"(152) Pipe Size	<input type="checkbox"/>
8	8"(203) Pipe Size	<input type="checkbox"/>

Outlet Type (Select One)		
Suffix	Description	
NH	No Hub (MJ)	<input type="checkbox"/>
P	Push On	<input type="checkbox"/>
T	Threaded Outlet	<input type="checkbox"/>
X	Inside Caulk	<input type="checkbox"/>

Options (Select One or More)		
Suffix	Description	
-A	Accutrol weir (specify # 1-6 slots)	<input type="checkbox"/>
-B	Sump Receiver Flange	<input type="checkbox"/>
-BED	Sump Receiver, Adj Ext., Deck Clamp	<input type="checkbox"/>
-C	Secondary Membrane Clamp	<input type="checkbox"/>
-D	Underdeck Clamp	<input type="checkbox"/>
-E	Adjustable Extension	<input type="checkbox"/>
-GSS	Stainless Steel Ballast Guard	<input type="checkbox"/>
-H	Adj. to 6" IRMA Ballast Guard	<input type="checkbox"/>
-K	Ductile Iron Dome	<input type="checkbox"/>
-K80	Aluminum Dome	<input type="checkbox"/>
-L	Vandal Proof Dome	<input type="checkbox"/>
-R	2" High External Water Dam	<input type="checkbox"/>
-SO	Side Outlet**	<input type="checkbox"/>
-V	Fixed Extension (1-1/2", 2", 3", 4")	<input type="checkbox"/>
-W	Adj. Water Level Regulator	<input type="checkbox"/>
-W-1	Waterproofing Flange	<input type="checkbox"/>
-Z	Extended Integral Wide Flange	<input type="checkbox"/>
-5	Sediment Bucket	<input type="checkbox"/>
-12	Galvanized Dome	<input type="checkbox"/>
-13	All Galvanized	<input type="checkbox"/>
-83	Mesh Covered Dome	<input type="checkbox"/>
-113M	Special Epoxy from 3M Range	<input type="checkbox"/>

Optional Body Material (NH Only)		
Suffix	Description	
-60	PVC Body w/Socket Outlet	<input type="checkbox"/>
-61	ABS Body w/Socket Outlet	<input type="checkbox"/>

** Side Outlet (-SO) option only available in 2"(51), 3"(76), 4"(102) pipe sizes.
Underdeck Clamp (-BED and -D options) are not available when -SO is selected.

Job Name _____ Contractor _____

Job Location _____ Contractor's P.O. No. _____

Engineer _____ Representative _____

WATTS Drainage reserves the right to modify or change product design or construction without prior notice and without incurring any obligation to make similar changes and modifications to products previously or subsequently sold. See your WATTS Drainage representative for any clarification. Dimensions are subject to manufacturing tolerances.



CANADA: 5435 North Service Road, Burlington, ON, L7L 5H7 TEL: 905-332-6718 TOLL-FREE: 1-888-208-8927 Website: www.wattsdrainage.ca



ACCUTROL WEIR FLOW CONTROL

SPECIFICATION: Watts Drainage Products epoxy coated cast iron Accutrol Weir is designed with parabolic openings which limit the flow of rain water off a roof. Each weir slot controls flow to 5 gpm per inch of head to a maximum of 30 gpm at 6" head (for large sump), 25 gpm at 5" head (for small sump). The Accutrol Weir is secured to the flashing clamp of the roof drain. The Accutrol Weir is available with 1 to 4 slots for the large sump drain and up to 3 slots for the small sump drain.

For Large Sump Roof Drains Specify the "-A" option and number of slots required. (ie. "RD-100-A2" for two slot weir)

For Small Sump Roof Drains Specify the "-A" option and number of slots required. (ie. "RD-200-A1" for one slot weir)

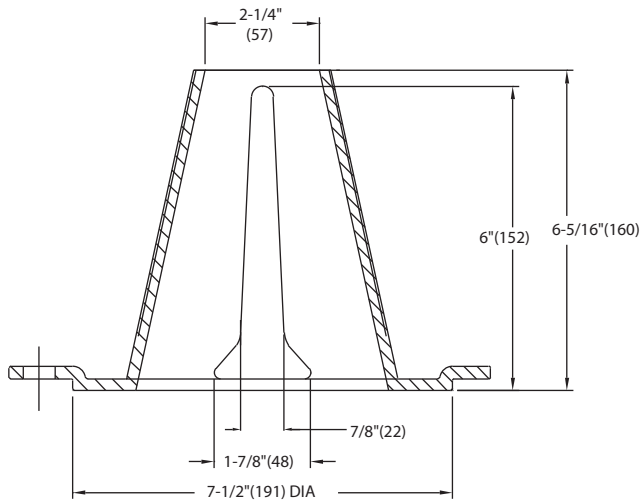

LARGE SUMP ACCUTROL WEIR

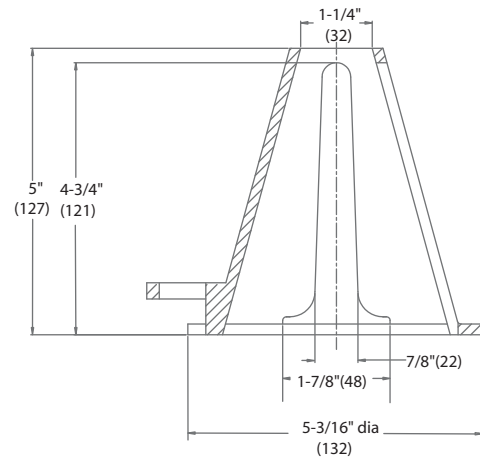

SMALL SUMP ACCUTROL WEIR

Job Name _____ Contractor _____

Job Location _____ Contractor's P.O. No. _____

Engineer _____ Representative _____

WATTS Drainage reserves the right to modify or change product design or construction without prior notice and without incurring any obligation to make similar changes and modifications to products previously or subsequently sold. See your WATTS Drainage representative for any clarification. Dimensions are subject to manufacturing tolerances.