



LeBreton Flats Zero Carbon Community Energy Plan

Final Report

1633030042



Prepared for:

National Capital Commission
202-40 Elgin St.
Ottawa, ON K1P 1C7

Prepared by:

Stantec Consulting Ltd.
300 – 1331 Clyde Avenue
Ottawa, ON K2C 3G4



March 4, 2022

Revision	Description	Author		Quality Check		Independent Review	
A	33% Draft	2021-06-04	NE	2021-06-04	AA	2021-06-04	JS
B	33% Draft Revised	2021-06-30	NE				
C	66% Draft	2021-08-27	NE	2021-08-27	AP	2021-08-27	JS
D	99% Draft	2021-10-15	NE	2021-10-15	AP	2021-10-15	JS
E	Final Report	2021-12-23	NE	2021-12-23	AP	2021-12-23	JS
F	Final Report Revised	2022-03-04	NE				



This document entitled LeBreton Flats Zero Carbon Community Energy Plan Final Report was prepared by Stantec Consulting Ltd. ("Stantec") for the account of National Capital Commission (NCC) (the "Client"). Any reliance on this document by any third party is strictly prohibited. The material in it reflects Stantec's professional judgment in light of the scope, schedule and other limitations stated in the document and in the contract between Stantec and the Client. The opinions in the document are based on conditions and information existing at the time the document was published and do not take into account any subsequent changes. In preparing the document, Stantec did not verify information supplied to it by others. Any use which a third party makes of this document is the responsibility of such third party. Such third party agrees that Stantec shall not be responsible for costs or damages of any kind, if any, suffered by it or any other third party as a result of decisions made or actions taken based on this document.

Attempts have been made to confirm the accuracy of the results. Variations in assumptions and building variables will affect the actual energy that the modelled buildings may use. For this reason, the assumptions presented in this report should be reviewed and any discrepancies brought to the attention of the appropriate Stantec contact. Where information was missing, assumptions have been made regarding parameters of the operation or performance of equipment and materials where data was not available. The use of these values and parameters shall in no way imply endorsement of a specific product or manufacturer.

The energy modelling results are not predictions of actual energy use or operating costs for the building after construction. Actual energy usage will differ from these calculations due to several variables. These variables may include, but are not limited to, variations in occupancy, building operations schedules, differences between actual weather and the typical meteorological year represented in the climate data file, energy use for equipment not included in the simulations, and changes in energy costs from the time of design to the time of occupancy.

Prepared by:



(signature)

Nick Ebbs, P.Eng., CEM, CMVP, CBCP

Prepared by:



Aaditya Patel, E.I.T., M.Eng., LEED GA

Reviewed by:



(signature)

Ahmed Kamel, P.Eng., M.Sc., LEED AP O+M

Reviewed by:

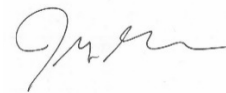

(signature)

**Jeff Schroeder, P.Eng., LEED AP BD+C, Principal,
Buildings Engineering Practice Lead**



Table of Contents

EXECUTIVE SUMMARY	X
1.0 INTRODUCTION	1.1
1.1 BACKGROUND	1.1
1.2 DEFINITION OF A ZERO CARBON COMMUNITY	1.2
1.3 APPROACH TO OPTIMIZATION	1.3
1.4 REPORT STRUCTURE	1.5
2.0 STUDY OVERVIEW AND METHODOLOGY	2.1
3.0 SITE CONDITIONS AND BUILDING ARCHETYPES	3.1
3.1 SITE CONDITIONS	3.1
3.2 CLIMATE	3.3
3.2.1 Present Climate	3.3
3.2.2 Future Climate	3.3
3.3 BUILDING ARCHETYPES	3.6
3.4 ENERGY MODELLING APPROACH	3.6
3.5 BUILDING PERFORMANCE TARGETS	3.7
3.6 NEW ZERO CARBON DISTRICT ENERGY SYSTEM	3.10
3.7 EXISTING DISTRICT ENERGY SYSTEMS	3.10
3.7.1 Zibi Community Utility (ZCU) District Energy System	3.10
3.7.2 Energy Services Acquisition Program (ESAP) District Energy System	3.12
3.8 ADDITIONAL ENERGY ELEMENTS	3.13
3.8.1 On-site Electricity Generation and Storage	3.13
3.8.2 Off-site Electricity Generation and Storage	3.14
3.8.3 On-site Thermal Generation and Storage	3.14
3.8.4 Process Load Waste Heat Recovery	3.14
3.8.5 Sewer Waste Heat Recovery	3.14
3.8.6 Food Service (Cooking) Loads	3.15
3.9 GHG EMISSION FACTORS OF ENERGY SOURCES CONSIDERED FOR LBF	3.16
3.9.1 Ontario Grid Electricity	3.16
3.9.2 Ontario Grid Natural Gas	3.17
3.9.3 Quebec Grid Electricity	3.18
3.9.4 Zibi Community Utility (ZCU) District Energy System	3.19
3.9.5 Energy Services Acquisition Program (ESAP) District Energy System	3.20
3.9.6 Emergency Generation	3.21
3.10 ACHIEVING NET-ZERO CARBON EMISSIONS	3.21
4.0 DESIGN OPTION DEVELOPMENT	4.1
4.1 BUILDING OPTIONS ANALYSIS	4.1
4.1.1 Summary and Overview of Options	4.1
4.1.2 Optimizing Envelope Performance	4.6
4.1.3 Optimizing Internal Loads	4.13
4.1.4 HVAC – Air Side	4.15
4.1.5 HVAC – Plant Side	4.17
4.1.6 Domestic Hot Water	4.19

LEBRETON FLATS ZERO CARBON COMMUNITY ENERGY PLAN

4.1.7	Control Strategies	4.21
4.1.8	Renewables	4.23
4.1.9	Building Level Summary.....	4.24
4.1.10	Building Level Recommendations	4.28
4.2	DISTRICT OPTIONS ANALYSIS.....	4.29
4.2.1	DES Loads.....	4.31
4.2.2	Option 1: LeBreton Flats Zero-Carbon DES	4.34
4.2.3	Option 2: Existing DES Plants	4.40
4.3	BASELINE GROUND SOURCE HEAT PUMP OPTION.....	4.41
4.4	DES SUMMARY.....	4.41
4.5	COMPARISON OF HVAC OPTIONS	4.42
4.6	ADDITIONAL ENERGY ELEMENTS	4.44
4.6.1	On-site Electricity Generation and Storage.....	4.44
4.6.2	Off-site Electricity Generation and Storage.....	4.44
4.6.3	On-site Thermal Generation and Storage.....	4.45
4.6.4	Process Load Waste Heat Recovery.....	4.46
4.6.5	Sewer Waste Heat Recovery	4.46
4.6.6	Food Service (Cooking) Loads.....	4.48
4.7	ADDITIONAL SUSTAINABILITY ELEMENTS	4.48
4.7.1	EV Parking and Charging Infrastructure	4.48
4.7.2	Bike Storage and Showers.....	4.49
4.7.3	Bird Friendly Buildings.....	4.49
4.7.4	Stormwater Management	4.49
4.7.5	Xeriscaping	4.49
4.7.6	Green Roofs.....	4.50
4.7.7	Waste Management.....	4.50
4.7.8	Embodied Carbon	4.50
4.8	URBAN LEVEL SUMMARY.....	4.51
5.0	ECONOMIC ANALYSIS.....	5.1
5.1	INTRODUCTION.....	5.1
5.2	KEY ASSUMPTIONS	5.1
5.2.1	Buildings	5.1
5.2.2	District Energy System.....	5.2
5.2.3	Utility Costs	5.3
5.2.4	Carbon Costs	5.5
5.3	ECONOMIC ANALYSIS SUMMARY	5.9
5.3.1	HVAC Capital Investment.....	5.9
5.3.2	DES Levelized Cost of Energy (LCOE)	5.11
5.3.3	Urban-Level Results.....	5.17
5.3.4	Sensitivity Analysis.....	5.20
6.0	CONCLUSIONS AND RECOMMENDATIONS	6.1
7.0	NEXT STEPS.....	7.1

LEBRETON FLATS ZERO CARBON COMMUNITY ENERGY PLAN

LIST OF APPENDICES

APPENDIX A	CONCEPT BENCHMARKS	A.1
Building Benchmarks		A.1
Stantec Tower, Edmonton, Alberta		A.1
Brock Commons Tallwood, Vancouver, British Columbia		A.2
Orion MURB, Pemberton, BC		A.4
Scotia Plaza’s 40 King St. W., Toronto, Ontario		A.6
evolv1, Waterloo, Ontario		A.7
District Energy Benchmarks		A.8
Marine Gateway District Energy		A.8
WestJet Campus Headquarters		A.9
Zibi Waterfront Development		A.10
CopenHill		A.12
The Well Building Toronto		A.13
District Energy St. Paul		A.14
Bucknell University 1.6MW Solar Array		A.15
Smart Flower Solar Array		A.16
APPENDIX B	STAKEHOLDER FEEDBACK	B.1
Workshop 1 – Achieving a Zero Carbon Community		B.1
Stakeholder Feedback		B.1
SWOT Analysis		B.2
Workshop 2 – Achieving a Zero Carbon Community: Building Performance		B.3
SWOT Analysis		B.3
APPENDIX C	ADDITIONAL LOW CARBON MEASURES	C.1
HVAC – Air Side		C.1
Right-Sized VAV AHUs with Heat Recovery		C.1
Chilled Beams with DOAS and Heat Recovery		C.2
Displacement Ventilation		C.3
VRF Heat Recovery (VRF-HR) Systems Coupled with District Energy System		C.4
Central Water-Source Heat Pumps coupled with District Energy System		C.6
Mixed-Mode Ventilation		C.8
IAQ Procedure for Outdoor Air Reduction		C.9
Renewables and Other Measures		C.10
PV Integrated Windows		C.10
Solar Preheat		C.10
Wind Turbines		C.11
Solar Hot Water Heating		C.12
Energy Storage		C.12
APPENDIX D	GHG EMISSIONS FACTORS	D.1
APPENDIX E	ANNUAL UTILITY RATES	E.1
APPENDIX F	DES THERMAL LOADS	F.1

LEBRETON FLATS ZERO CARBON COMMUNITY ENERGY PLAN

LIST OF TABLES

Table 3-1:	Building Performance Targets at a Glance.....	3.7
Table 3-2:	HPDS Tier 1 Performance Targets	3.8
Table 3-3:	LBF Specific Tier 1 Performance Targets	3.8
Table 3-4:	HPDS Tier 2 Performance Targets	3.9
Table 3-5:	LBF Specific Tier 2 Performance Targets	3.9
Table 3-6:	LBF Specific Net Zero-Carbon Performance Targets	3.10
Table 3-7:	Forecast GHG Emission Intensity of Ontario’s Electrical Grid	3.17
Table 3-8:	Forecast GHG Emission Intensity of ESAP Energy Sources	3.21
Table 4-1:	Overview of Building Performance Targets	4.1
Table 4-2:	Summary of Building Elements – Archetype 1	4.3
Table 4-3:	Summary of Building Elements – Archetype 2	4.4
Table 4-4:	Summary of HVAC Options	4.43
Table 5-1:	Summary of Utility Costs.....	5.5
Table 5-2:	Summary of Carbon Costs.....	5.9
Table 5-3:	DES LCOE Rates	5.16

LIST OF FIGURES

Figure 1-1:	Aerial View of LeBreton Flats	1.1
Figure 1-2:	Net-Zero Carbon Community Definition at LBF	1.3
Figure 1-3:	The Optimization Process: Towards Net-Zero Energy and Carbon	1.4
Figure 3-1:	Aerial View of LeBreton Flats	3.1
Figure 3-2:	LeBreton Flats Master Concept Plan – Phasing Plan.....	3.2
Figure 3-3:	CWEC 2016 – Present Climate (Ottawa)	3.4
Figure 3-4:	RCP 8.5 – 2031 to 2050 – 90th Percentile (Ottawa).....	3.4
Figure 3-5:	Summary of Future Climate in Canada’s Capital Region.....	3.5
Figure 3-6:	Rendering of Building Archetypes with Select Adjacent Buildings, Viewed from the North.....	3.7
Figure 3-7:	ZCU DES Map	3.12
Figure 3-8:	ESAP DES Map.....	3.13
Figure 3-9:	SHARC Sewer Heat Recovery System.....	3.15
Figure 3-10:	ESAP Deeper Greening Efforts and Changes to the Source of Heating and Cooling.....	3.20
Figure 4-1:	Air-to-Air Energy Recovery	4.16
Figure 4-2:	Drain Water Heat Recovery System.....	4.21
Figure 4-3:	Archetype 1 Performance Metrics Achieved vs. Benchmarks.....	4.25
Figure 4-4:	Archetype 2 Performance Metrics Achieved vs. Benchmarks.....	4.26
Figure 4-5:	Archetype 1 End Use EUI Breakdown.....	4.27
Figure 4-6:	Archetype 2 End Use EUI Breakdown.....	4.27
Figure 4-7:	District Heating and Cooling System	4.30
Figure 4-8:	LeBreton Flats Floor Area Development	4.32
Figure 4-9:	LeBreton Flats Thermal Loads	4.33
Figure 4-10:	4-Pipe District Energy System.....	4.36
Figure 4-11:	2-Pipe Ambient Temperature District Energy System	4.37
Figure 4-12:	DES Space Heating and Space Cooling Energy	4.41
Figure 4-13:	DES Space Heating and Space Cooling GHG Emissions	4.42
Figure 4-14:	Total Urban Energy Use.....	4.52

LEBRETON FLATS ZERO CARBON COMMUNITY ENERGY PLAN

Figure 4-15: Total GHG Emissions4.53
Figure 5-1: HVAC Capital Cost Breakdown (\$2020M).....5.10
Figure 5-2: Cash Flow 4-Pipe Option A (Current \$M).....5.13
Figure 5-3: Cash Flow 4-Pipe Option C (Current \$M).....5.14
Figure 5-4: Cash Flow 2-Pipe Option A (Current \$M).....5.15
Figure 5-5: Cash Flow 2-Pipe Option C (Current \$M).....5.16
Figure 5-6: Net Present Value of Urban Scenarios.....5.19
Figure 5-7: Net Present Value of HVAC Options5.21
Figure 5-8: Effect of Sensitivity Analysis on HVAC Options.....5.22
Figure 5-9: Effect of Sensitivity Analysis on Urban Scenarios5.23

LEBRETON FLATS ZERO CARBON COMMUNITY ENERGY PLAN

Definitions

American Society for Heating, Refrigeration, and Air Conditioning Engineers (ASHRAE)	ASHRAE is an American professional association seeking to advance heating, ventilation, air conditioning, and refrigeration (HVAC&R) systems design and construction. It publishes standards and guidelines that are often referenced in Canadian building codes, including OBC and NECB.
Building Archetypes	Building archetypes are theoretical buildings created by a composite of several characteristics found within a category of buildings with similar attributes. Therefore, an archetype is a virtual representation of several buildings that share similar characteristics in the stock.
Canada Green Building Council (CaGBC)	The Canada Green Building Council is a not-for-profit, national organization that has been working since 2002 to advance green building and sustainable community development practices in Canada. The CaGBC is the Canadian license holder for the LEED green building rating system and supports the WELL Building Standard in Canada.
Canadian Weather for Energy Calculations (CWEC)	CWEC is an engineering climate dataset that is typically used for running energy simulations. It is created by joining twelve typical meteorological months selected from a database of up to 30 years of location specific hourly weather data.
Carbon Offset	A carbon offset, also known as a carbon offset credit or offset credit, is a reduction in emissions of greenhouse gases made in order to compensate for emissions generated elsewhere. Carbon offsets can be purchased on the market to achieve net-zero emissions from a variety of activities, including onsite building fossil fuel combustion.
Community Energy Plan (CEP)	A CEP is an integrated approach to energy planning by aligning energy, infrastructure, and land use planning, setting a sustainable direction for a community's future development.
Cooling Degree Days (CDD)	A cooling degree day (CDD) is a measurement designed to quantify the demand for energy needed to cool buildings. It is the number of degrees that a day's average temperature is above a specified balance point, typically 18° Celsius (65° Fahrenheit).
District Energy System (DES)	District energy systems are networks of hot and cold-water pipes, typically buried underground, that are used to efficiently heat and cool multiple buildings, often using less energy than if the individual buildings were to each have their own boilers and chillers.
Embodied Carbon	Embodied carbon refers to the greenhouse gas emissions arising from the manufacturing, transportation, installation, maintenance, and disposal of building materials at the end of their lifetime. It is also referred to as embedded carbon.
Energy Services Acquisition Program (ESAP)	The Energy Services Acquisition Program includes the energy services modernization project, which will modernize several district energy systems in the National Capital Region (NCR). The project will involve the conversion of the system from steam to low-temperature hot water for heating, as well as replacing fossil fuels with renewable alternatives.

LEBRETON FLATS ZERO CARBON COMMUNITY ENERGY PLAN

Greenhouse Gas Emissions Intensity (GHGI)	The total greenhouse gas emissions associated with the use of all energy utilities on site per unit of modelled floor area. GHGI will be reported in kgCO _{2e} /m ² /year for this study.
Heating Degree Days (HDD)	A heating degree day (HDD) is a measurement designed to quantify the demand for energy needed to heat a building. It is the number of degrees that a day's average temperature is below a specified balance point, typically 18° Celsius (65° Fahrenheit), which is the temperature below which buildings need to be heated.
High Performance Development Standard (HPDS)	The City of Ottawa's High Performance Development Standard (HPDS) is a new standard currently being developed that will set performance targets for new construction to achieve sustainable development and climate change goals. The version referenced at the time of writing this report was HPDS Draft 2021.F66.
Independent Electricity System Operator (IESO)	The Independent Electricity System Operator is the Crown corporation responsible for operating the electricity market and directing the operation of the bulk electrical system in the province of Ontario, Canada.
Integrated Design Process (IDP)	The Integrated Design Process (IDP) is a method for realizing high performance buildings that contribute to sustainable communities. It is a collaborative process that focuses on the design, construction, operation, and occupancy of a building over its complete life cycle.
Integrated Environmental Solutions Virtual Environment (IES VE)	IES VE is an integrated software for whole-building performance simulation. It provides integrated analysis tools for the design and optimization of buildings. IES VE is the energy modelling software employed for this project.
Intergovernmental Panel on Climate change (IPCC)	The Intergovernmental Panel on Climate Change (IPCC) is the United Nations body for assessing the science related to climate change. The IPCC provides regular assessments of the scientific basis of climate change, its impacts and future risks, and options for adaptation and mitigation.
Key Performance Indicator (KPI)	A Key Performance Indicator (KPI) is a measurable value that indicates progress towards a project outcome or result.
LBF Master Concept Plan (MCP)	The LeBreton Flats Master Concept Plan is a foundational document that sets out a bold and compelling vision for the Building LeBreton project. The Plan addresses the remarkable opportunity to reinvigorate Ottawa's LeBreton Flats, drawing out the neighbourhood's unmistakable potential and transforming it into a dynamic Capital destination.
LeBreton Flats (LBF)	LeBreton Flats is a 29-hectare site anchored by two LRT stations at Pimisi and Bayview, aqueduct water features, and Nepean Inlet, with access to the Ottawa River. It is slated for a large redevelopment into a mixed-use neighbourhood including residential, commercial, institutional, green, and open spaces.
Levelized Cost of Energy (LCOE)	Levelized Cost of Energy (LCOE) is routinely used in public energy utilities planning and analysis, especially when comparing electrical power supply options. It allows for a meaningful comparison between energy supply options that have very different capital costs, fuel costs, etc. and are therefore difficult to compare with other metrics.

LEBRETON FLATS ZERO CARBON COMMUNITY ENERGY PLAN

Life-cycle Costing Assessment (LCCA)	Lifecycle cost analysis (LCCA) is a tool to determine the most cost-effective option among different competing alternatives to purchase, own, operate, maintain and, finally, dispose of an object or process, when each is equally appropriate to be implemented on technical grounds.
National Capital Commission (NCC)	The National Capital Commission is the federal Crown corporation dedicated to ensuring that Canada's Capital is a dynamic and inspiring source of pride for all Canadians, and a legacy for generations to come.
National Energy Code of Canada (NECB)	The NECB is published by the National Research Council (NRC) and developed by the Canadian Commission on Building and Fire Codes in collaboration with Natural Resources Canada (NRCan), sets out technical requirements for the energy efficient design and construction of new buildings. NECB is referenced as a standard by the OBC.
Net Present Value (NPV)	Net present value (NPV) is the difference between the present value of cash inflows and the present value of cash outflows over a period of time. A positive NPV indicates that the project generates revenue over its lifetime and a negative NPV indicates a net loss.
Ontario Building Code (OBC)	The Ontario Building Code is a regulation under the Building Code Act that establishes the minimum standards for building construction in Ontario. The specific requirements related to energy efficiency are stipulated in the Supplemental Standard 'SB-10' of the OBC.
Ontario Power Generation (OPG)	Ontario Power Generation Inc. is a Crown corporation responsible for approximately half of the electricity generation in the province of Ontario, Canada. It is wholly owned by the Government of Ontario. Sources of electricity include nuclear, hydroelectric, wind, gas, and biomass.
Power Purchase Agreement (PPA)	A Power Purchase Agreement (PPA), or electricity power agreement, is a contract between two parties, one which generates electricity (the seller) and one which purchases the electricity (the buyer). The PPA defines all the commercial terms for the sale of electricity between the two parties, including when the project will begin commercial operation, schedule for delivery of electricity, penalties for under delivery, payment terms, and termination. PPAs are often used as an alternative to RECs, especially for large consumers of electricity.
Renewable Energy Certificate (REC)	A renewable energy certificate, also known as a renewable energy credit, is a market instrument that allows renewable energy generation to be traded as an energy commodity. A REC is a particular type of carbon offset, commonly used to offset the carbon emissions associated with purchased grid electricity, by ensuring that an equivalent of renewable generation is added to the grid as was consumed by the end user. Buying RECs is not equivalent to buying electricity. Instead, RECs represent the clean energy attributes of renewable electricity, and allow a pathway to achieving net-zero emissions from electricity use.
Renewable Natural Gas (RNG)	RNG, also known as biogas, is a carbon-neutral fuel that is created by capturing methane emissions from sources such as organic waste, landfills, and wastewater treatment plants. RNG can be mixed into the natural gas distribution grid or stored and consumed separately.

LEBRETON FLATS ZERO CARBON COMMUNITY ENERGY PLAN

Representative Concentration Pathway (RCP)	A Representative Concentration Pathway (RCP) is a greenhouse gas concentration (not emissions) trajectory adopted by the IPCC. Four pathways were used for climate modeling and research for the IPCC fifth Assessment Report (AR5) in 2014. The pathways describe different climate futures, all of which are considered possible depending on the volume of greenhouse gases (GHG) emitted in the years to come.
Return on Investment (ROI)	Return on investment is a performance measure used to evaluate the efficiency or profitability of an investment or compare the efficiency of a number of different investments. ROI tries to directly measure the amount of return on a particular investment, relative to the investment's cost.
The Atmospheric Fund (TAF)	The Atmospheric Fund (TAF) is a regional climate agency that invests in low-carbon solutions for the Greater Toronto and Hamilton Area and helps scale them up for broad implementation. Formerly known as the Toronto Atmospheric Fund.
Thermal Energy Demand Intensity (TEDI)	The annual heating energy demand for space conditioning and conditioning of ventilation air, per unit of modelled floor area. Achieving high TEDI performance is crucial to low carbon building design in Ottawa's climate. TEDI will be reported in kWh/m ² /year for this study.
Total Energy Use Intensity (TEUI)	The sum of all energy used on site (e.g., electricity, natural gas, district heat), minus all renewable energy generated (e.g., solar PV) on site, divided by the modelled floor area. TEUI allows for benchmarking and comparison of the energy performance of buildings. TEUI will be reported in kWh/m ² /year for this study.
Typical Meteorological Year (TMY)	A typical meteorological year (TMY) is a set of meteorological data with data values for every hour in a year for a given geographical location. The data are selected from hourly data in a longer time period (normally 10 years or more). For each month in the year the data have been selected from the year that was considered most "typical" for that month. For instance, January might be from 2007, February from 2012 and so on.
Zero Carbon Building Design (ZCB-Design) Standard	The Zero Carbon Building - Design (ZCB-Design) Standard is a made-in-Canada framework for designing and retrofitting buildings to achieve zero carbon. The ZCB-Design Standard evaluates carbon emissions across the building life cycle, including construction and operation.
Zibi Community Utility (ZCU)	The Zibi Community Utility is a District Energy System relying on effluent energy recovery from local Kruger Products plant for heating, and the Ottawa River for cooling.

Executive Summary

On April 22, 2021, the NCC Board of Directors approved the final Master Concept Plan (MCP) for LeBreton Flats (LBF) as a dynamic Capital destination and complete community where people can live, work, and play. To support the MCP, a comprehensive Community Energy Plan (CEP) was prepared by Stantec to provide guidance on the next steps to take with respect to building development.

In order to achieve the MCPs strategy for developing a zero carbon and sustainable community at LBF, the CEP makes the following recommendations:

- **Building Performance Targets:** Buildings should be developed according to industry best practices for zero-carbon building design, prioritizing energy efficiency first, followed by renewable energy generation, and finally using high quality carbon offsets to balance out difficult to avoid carbon emissions and achieve net-zero carbon over the lifetime of the development. This has been demonstrated to be a cost effective and socially responsible way to achieve zero carbon developments. This can be simply accomplished with minimal effort from NCC by requiring that buildings comply with the CaGBC's Zero Carbon Building Design and Performance Standards.
- **District Energy System:** A net-zero carbon district energy system (DES) should be developed and operated by qualified 3rd parties with a mandate to provide thermal energy (space heating and cooling) to all of the buildings at LBF. This approach has comparable economic outcomes to allowing the building developers to construct individual low carbon heating and cooling systems for each building, with the benefit of transferring the significant upfront capital costs to the DES developer who can recover the investment over a longer timeframe. Additional benefits include improved system reliability and flexibility with the option of incorporating more sustainable energy sources into the system, including waste heat recovery. NCC can accomplish this by securing the services of an Owner's Representative who will guide them through the process of procuring a DES developer and operator.
- **DES Ready Framework:** In order to balance the need to begin developing non-contiguous parcels at LBF in the near term with the longer-term development horizon for a DES, building development can begin under a "DES ready" framework, whereby buildings install temporary space heating and cooling systems to serve their needs until the operational DES is ready for connection. Such frameworks are commonplace and form part of the City of Ottawa's proposed High Performance Development Standards. NCC can accomplish this by requiring that the standards for this framework be developed during the DES procurement process, allowing for building development to proceed without delay.

The following are the recommended next steps for NCC to take:

- **Building Development:** Create mandates for building performance and mandatory DES connection for building developers to follow as a requirement for developing parcels at LBF.
- **DES Development:** Secure the services of a qualified Owner's Representative to support NCC through the process of procuring a DES developer and operator.



1.0 INTRODUCTION

1.1 BACKGROUND

The National Capital Commission (NCC) has embarked on a process to create a renewed vision for a dynamic Capital destination and a complete community where people can live, work, and play. On April 22, 2021, the NCC Board of Directors approved the final Master Concept Plan¹ (MCP) for LeBreton Flats (LBF). Based on public feedback, this plan envisions a place that is pedestrian- and cyclist-friendly, surrounded by lively and active parks and plazas including the dynamic Aqueduct District, the Ottawa riverfront, and a large destination park. A future, diverse residential community will be supported by retail and employment opportunities, capitalizing on direct access to two light rail transit (LRT) stations. This MCP will guide the implementation of the project using a strategically phased approach over the coming decades.

The purpose of this study is to investigate, analyze, and develop options for energy and carbon neutrality of the site development, to help achieve a zero-carbon community.



Figure 1-1: Aerial View of LeBreton Flats²

To support the final MCP, a comprehensive Community Energy Plan (CEP) is required to further develop the sustainability strategies indicated in the MCP. To reduce greenhouse gas (GHG) emissions and energy

¹ <https://ncc-ccn.gc.ca/projects/lebreton-flats-master-concept-plan>

² National Capital Commission



LEBRETON FLATS ZERO CARBON COMMUNITY ENERGY PLAN

Introduction

consumption locally, it is critical that the CEP includes leading energy strategies and development options. For this reason, the NCC has retained Stantec Consulting Ltd. (Stantec) to conduct Community Energy Plan study for LBF. The purpose of this study is to investigate, analyze, and develop options for energy and carbon neutrality of the site development, to help achieve a zero carbon community.

1.2 DEFINITION OF A ZERO CARBON COMMUNITY

A zero carbon community can be defined in a number of ways; although there is no standardized definition, the following elements are included to a greater or lesser extent:

- Minimizing the embodied carbon content of buildings in the community by including low carbon materials, including high levels of local and recycled content, and minimizing construction waste. Most strategies focus on reducing embodied carbon associated with construction, but there is an increasing focus on designing buildings that will be easier to demolish and recycle at end-of-life.
- Minimizing site energy use for buildings and transportation within the community.
- Minimizing the generation of waste products within the community, including repurposing waste streams for other purposes such as compost and energy.
- Maximizing the fraction of renewable energy sources used to generate community energy use, either through on-site renewable generation within the community or through off-site renewable generation.
- Purchasing renewable energy certificates (RECs) and high-quality carbon offsets to balance out the remaining carbon emissions associated with the community.

A zero carbon community typically includes the following elements:

- Minimizes the embodied carbon content of buildings.
- Minimizes site energy use for buildings and transportation.
- Minimizes generation of waste.
- Maximizes renewable energy sources for use to power the community.
- Purchases renewable energy certificates and carbon offsets to balance out carbon emissions.

The extent to which each of these elements are implemented depends on the specific conditions of the community, but zero-carbon strategies encourage the reduction of carbon first, followed by RECs and carbon offsets, to make up the difference. Most zero-carbon building and community strategies recognize that some carbon emissions are inevitable even with current best practices, and therefore allow for the purchase of high-quality carbon offsets (i.e., net-zero carbon).

With reference to the LBF MCP, LBF will be a net-zero carbon community that embeds a culture of excellence and sustainability throughout the lifecycle of the project.

- **Operational carbon:** Eliminate carbon emissions resulting from operating energy use, including on-site combustion of fuels and indirect emissions from electricity use supplied from the grid.
- **Embodied carbon:** Reduce carbon emissions from the manufacturing, transport, installation, use, and end-of-life disposal of building materials.



LEBRETON FLATS ZERO CARBON COMMUNITY ENERGY PLAN

Introduction

- **Transportation carbon:** Reduce carbon emissions resulting from occupant transportation to and from the LBF plan area.
- **Consumption-based carbon:** Reduce carbon emissions from the production and use of goods and services consumed in the region, regardless of where those emissions occur globally.

The MCP can therefore be considered to be consistent with best practice definitions for a net-zero carbon community. The equation in Figure 1-2 was proposed during the initial stakeholder engagement workshop, to envision a net-zero carbon community at LBF.

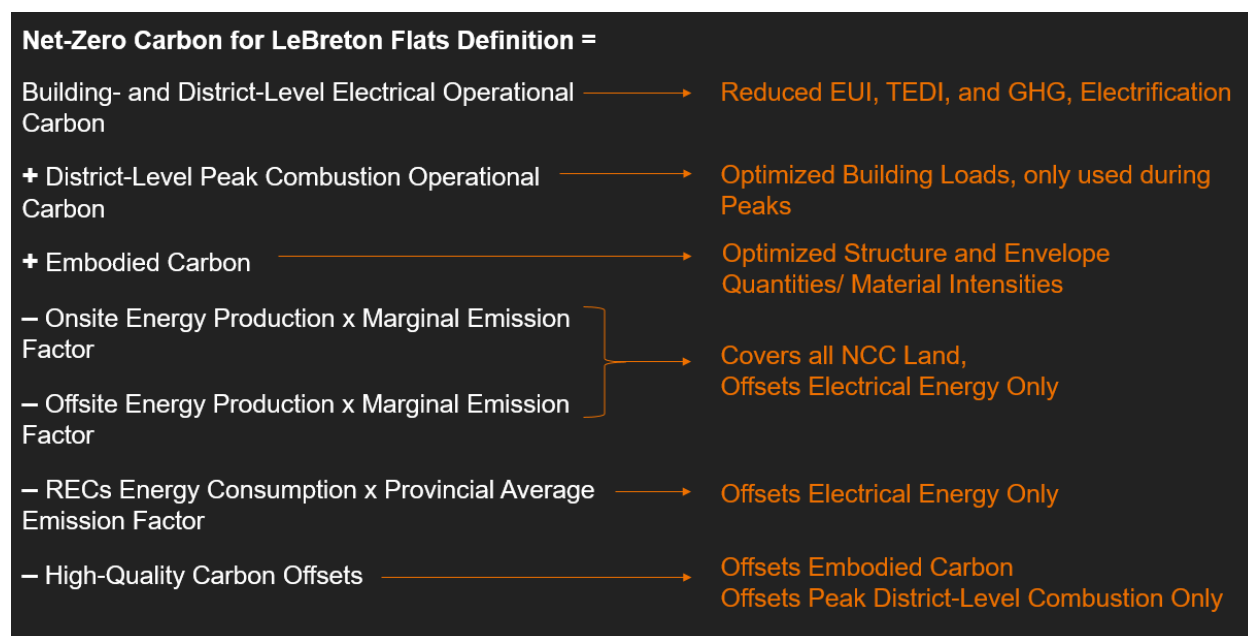

Figure 1-2: Net-Zero Carbon Community Definition at LBF

Consequently, the scope of this project investigates the potential of LBF to achieve carbon neutrality, that is, how the site can achieve net-zero carbon emissions on an annual basis.

1.3 APPROACH TO OPTIMIZATION

Stantec has four key values: we put people first, we do what is right, we are better together, and we are driven to achieve. This statement embodies our imperative to commit ourselves to tackling Climate Change by “doing what is right”, being “driven to achieve tangible results”, and challenging the conventional notions of “business as usual”. Each of these core values was integrated into a process which followed the NCC statement of work and was integral in achieving a preferred design.

The combination of the above four values complements the design philosophy of this zero-carbon energy plan, which used an Integrated Design Process (IDP) to harness the collective power of the stakeholders and the subject matter experts to identify potential carbon conservation measures relevant to these buildings.



LEBRETON FLATS ZERO CARBON COMMUNITY ENERGY PLAN

Introduction

The process of arriving at the unique conservation measures was structured to look first at tenant, then passive, then active, and finally renewable energy strategies as outlined in Figure 1-3 below.

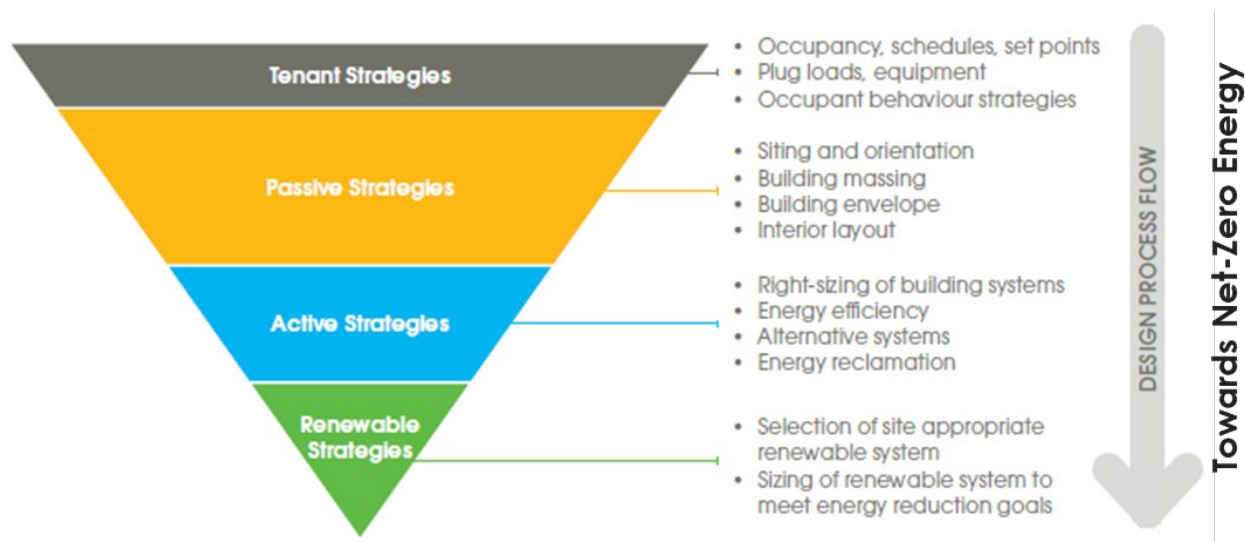

Figure 1-3: The Optimization Process: Towards Net-Zero Energy and Carbon

The process of arriving at the unique conservation measures was as follows:

1. Assess tenant strategies
2. Assess passive strategies
3. Assess active strategies
4. Assess renewable energy strategies

This was done to optimize the energy and carbon savings by first reducing the loads of the buildings through passive technology, then reducing the energy required to heat, cool, and ventilate the buildings by looking at high performance HVAC systems, and ensuring that the HVAC systems are controlled using the latest smart control strategies.

Both the passive and active strategies can reduce the buildings' energy greatly but will not be enough to achieve a net-zero carbon building.

The passive and active strategies can potentially reduce a building's consumed energy use intensity (EUI) to between approximately 50 and 100 ekWh/m²/year, by following the leading sustainable low and net zero energy high-performance design for buildings.

The final step in the process once all passive and active strategies have been analyzed is to assess the potential of the buildings and site to incorporate renewable systems. In the case of LBF, district energy options will be evaluated for optimizing and decarbonizing the generation of energy required for heating and cooling buildings.

RECs and carbon offsets are employed as a stopgap measure to meet net-zero carbon once the other options have been fully pursued.



1.4 REPORT STRUCTURE

This report is structured as follows:

1. **Introduction:** A brief overview of the project.
2. **Study Overview and Methodology:** An outline of the process followed from start to finish to eventually arrive at the study recommendations.
3. **Site Conditions and Building Archetypes:** A summary of the site conditions, the archetype buildings chosen to represent the future LBF development, as well as a summary of the energy sources available to LBF and their associated GHG emissions intensities.
4. **Design Options Development:** A description of the design options that were evaluated for buildings, district energy, and additional urban energy and sustainability elements.
5. **Economic Analysis:** An analysis of the project economics, including utility cost savings, incremental project costs, and lifecycle costing assessment (LCCA).
6. **Conclusion and Recommendations:** An overall discussion and final conclusions and recommendations of the study.
7. **Next Steps:** Specific next steps that NCC can take to support the development of the zero carbon community envisaged in the MCP.



2.0 STUDY OVERVIEW AND METHODOLOGY

To develop a zero carbon CEP for LBF, the following tasks were undertaken.

1. Reviewed Previous Investigations and Studies

- Reviewed previous studies and analyses for sustainability initiatives, including carbon neutrality, which have been investigated for LBF, including the following:
 - The LeBreton Flats MCP prepared by NCC
 - Net-Zero Carbon at LeBreton Flats prepared by Urban Equation
 - Zero Carbon Report – Roadmap to Zero Carbon prepared by Urban Equation
 - LeBreton Flats as Net Zero Emissions Community Strategy and Plan prepared by Ottawa Renewable Energy Co-operative (OREC)
 - Sustainable Development Strategy 2018–2023 prepared by NCC
- Reviewed other relevant sources of information for the project, including the following:
 - Zero Carbon Building Design Standard prepared by the Canada Green Building Council (CaGBC)
 - Zero Carbon Building Performance Standard prepared by CaGBC
 - Draft High Performance Development Standard prepared by the City of Ottawa

2. Stakeholder Consultation Workshops

- Conducted three workshops with project stakeholders and industry experts to solicit feedback:
 - Workshop #1: Achieving a Zero Carbon Community. What is the vision for LeBreton Flats' Community Energy Plan to achieve the objectives of the Master Concept Plan?
 - Workshop #2: Building Performance. Define energy performance benchmarks and evaluate pathways to achieving zero carbon buildings.
 - Workshop #3: District Energy. Technical and economic potential for developing a zero-carbon district energy system to serve LeBreton Flats.

3. Energy Model Development and Options Analysis

- Created building energy model archetypes that are representative of the planned developments consistent with the MCP.
- Developed three building energy performance targets for different scenarios including a minimum performance baseline, improved performance, and enhanced performance.
- Developed a feasible bundle of sustainability measures as a design option which achieves the stated energy and GHG reductions for each of the three performance targets. The measures used in each design option will vary, in order to meet each target. Each bundle of measures will be selected based on technical analysis, professional judgment and experience, and consultation with stakeholders.
- Modeled the energy and carbon emissions under the different building energy performance scenarios.
- Modeled the district energy system (DES) loads under the carbon neutral scenario.



LEBRETON FLATS ZERO CARBON COMMUNITY ENERGY PLAN

Study Overview and Methodology

4. District Energy System Analysis

- Developed options analysis comparing development of a new district energy system (DES) local to LBF, connection to nearby DES, and evaluation of renewable energy generation off-site on other NCC lands.
- Through these options, the possible roles of the NCC was evaluated as well as the potential to include third-party vendors and operators.
- Description of the final design options for buildings and DES.

5. Economic Analysis

- Lifecycle cost analysis (LCCA) of the proposed zero carbon options compared to the baseline scenarios.
- Implications of developing in a phased approach.
- Development of a business case to support the potential development of a local DES at LBF.

6. Conclusions and Recommendations

- Summarizing the findings and developing recommendations for building energy performance targets and design concepts, DES options, off-site renewable energy generation, RECs, and carbon offsets.

7. Next Steps

- Development of specific guidance that NCC can follow in order to achieve the sustainable development objectives outlined in the MCP.



3.0 SITE CONDITIONS AND BUILDING ARCHETYPES

The following section provides a summary of the existing site conditions and proposed buildings.

3.1 SITE CONDITIONS

As shown in Figure 3-1 below, LBF is located just 1.5 km west of the Capital’s Parliamentary Precinct and central business district. The 29-ha site is anchored by two LRT stations at Pimisi and Bayview, by aqueduct water features, and by the Nepean Inlet, with access to the Ottawa River.



Figure 3-1: Aerial View of LeBreton Flats³

The MCP divides the entire area into parcels, which are intended to be developed using a phased approach over an estimated 30-year timeframe, as shown in Figure 3-2.

³ Source: National Capital Commission



LEBRETON FLATS ZERO CARBON COMMUNITY ENERGY PLAN

Site Conditions and Building Archetypes



Figure 3-2: LeBreton Flats Master Concept Plan – Phasing Plan⁴

The tentative timing of the MCP Phasing Plan is as follows.

- **Early Phase** (1–10 years), shown in red.
 - Parcels A9 and A10, also known as the Library Parcel, are currently being disposed of and consequently will not be in scope for this study.
- **Middle Phase** (10–20 years), shown in purple.
- **Late Phase** (20–30 years), shown in green.
 - All Late Phase sites could potentially be developed during the Early or Middle phases, should an opportunity to do so arise.

The MCP provides a framework for developing a mixed-use community of approximately 11.8 ha, not including the Park District, public realm projects, and public roads. The following are the development targets for the site:

- Gross floor area of 520,000 m², divided among:
 - 430,000 m² of residential space (82.7%)

⁴ <https://ncc-website-2.s3.amazonaws.com/documents/LeBreton-Flats-Master-Concept-Plan-1.pdf?mtime=20210422120531&focal=none>, p. 106, Figure 61



LEBRETON FLATS ZERO CARBON COMMUNITY ENERGY PLAN

Site Conditions and Building Archetypes

- 65,000 m² of office space (12.5%)
- 25,000 m² of retail space (4.8%)
- 4,000 dwelling units
- 7,500 new residents
- 3,750 post-construction jobs

The NCC is restricted in its ability to borrow money and finance projects; consequently, the MCP envisions that parcel of land will be disposed of through sales and long-term ground leases to developers in stages to enable development.

3.2 CLIMATE

High-performance building design standards strongly recommend that future climate conditions be considered when designing new buildings. The CaGBC's Zero Carbon Building (ZCB) standard recommends a timeframe of 60 years for the evaluation of a ZCB, which has been adopted for this study. Since the development at LBF is expected to begin in 2025 and be completed by 2051, the appropriate timeframe for this study is 2025 to 2111, to allow for a full 60-year lifecycle of the buildings constructed in 2051.

3.2.1 Present Climate

As per the NECB 2017 and ASHRAE 90.1, Ottawa is classified as Climate Zone 6A (Cold – Humid). According to the Ontario Building Code (OBC), the winter design temperature is -27°C (-16.6°F). The summer design temperatures are 30°C dry bulb and 23°C wet bulb (86°F and 73°F, respectively). The base 18°C (64°F) heating degree days (HDD_{18C}) are 4,500.

3.2.2 Future Climate

A climate analysis by Stantec using data from Environment and Climate Change Canada revealed that Ottawa's climate zone will likely change from a Climate Zone 6a (Cold – Humid) to a 5a (Cool – Humid) within a period of 25 years, depending on the climate prediction scenario. Ottawa's warmest month will continue to be July and the coldest month will continue to be January. The maximum annual summer design temperature will increase from 32.8°C (89.4°F) to approximately 35.7°C (94.8°F), depending on the magnitude of climate change. The minimum annual temperature will be slightly warmer, as it will change from -30.0°C (-22.0°F) to -24.9°C (-18.6°F).

Figure 3-3 and Figure 3-4 demonstrate the rise in temperatures between the current Canadian Weather Year for Energy Calculation (CWEC) 2016 weather file and future predictions, with the higher carbon emissions scenario (RCP 8.5) at the most extreme warming scenario (90th percentile). The heat maps reveal how the spread and frequency of higher temperatures (red) will increase throughout the year. The frequency of the coldest temperatures (blue) will reduce in the winter. The climate change trend is expected to continue beyond 2050.



LEBRETON FLATS ZERO CARBON COMMUNITY ENERGY PLAN

Site Conditions and Building Archetypes

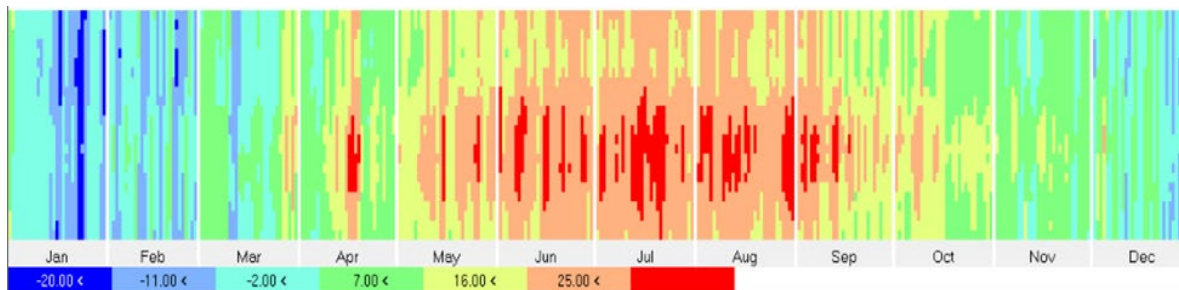

Figure 3-3: CWEC 2016 – Present Climate (Ottawa)⁵

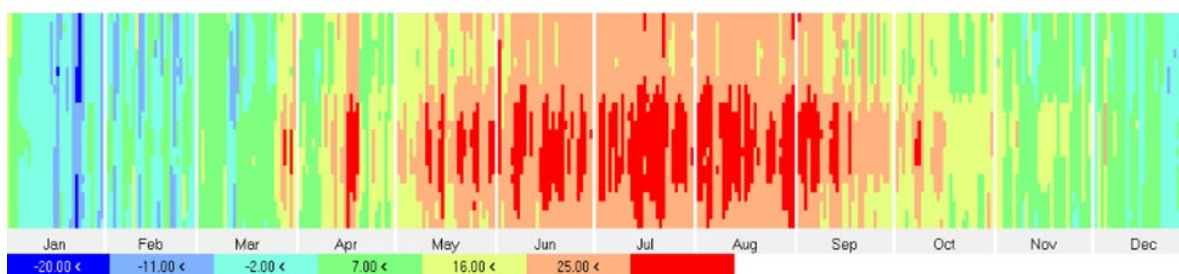

Figure 3-4: RCP 8.5 – 2031 to 2050 – 90th Percentile (Ottawa)⁶

Similar trends are also confirmed by a detailed climate forecasting study carried out by the NCC and City of Ottawa and specific to Canada’s Capital Region and summarized in Figure 3-5 below. The average temperature is predicted to continue to rise over the coming century, and summers would see nearly 6.5 times the number of hot days (above 30°C) as are present today. With this trend, we would also see Cooling Degree Days (CDD) increase by nearly 200% from present levels. This has significant implications on the system design, considering the increased run time throughout the summer months. With the continued effects of global warming, it is also expected that winters would become milder over the century and that very cold days (below -10°C) would decrease by 65% from present levels. Other trends include increased precipitation and decrease in snowfall over the century. Extreme events such as freezing rain, tornadoes, lightning, hurricanes, and wildfires are also projected to increase.

Climate models forecast that Ottawa’s climate will become hotter and wetter between now and the end of the century, continuing the recent trends. Extreme weather events are also expected to increase. The impact that this will have on the design and operation of the proposed development at LBF has been accounted for in the analysis.

⁵ CWEC 2016 and IES VE

⁶ Weathershift and IES VE



LEBRETON FLATS ZERO CARBON COMMUNITY ENERGY PLAN

Site Conditions and Building Archetypes

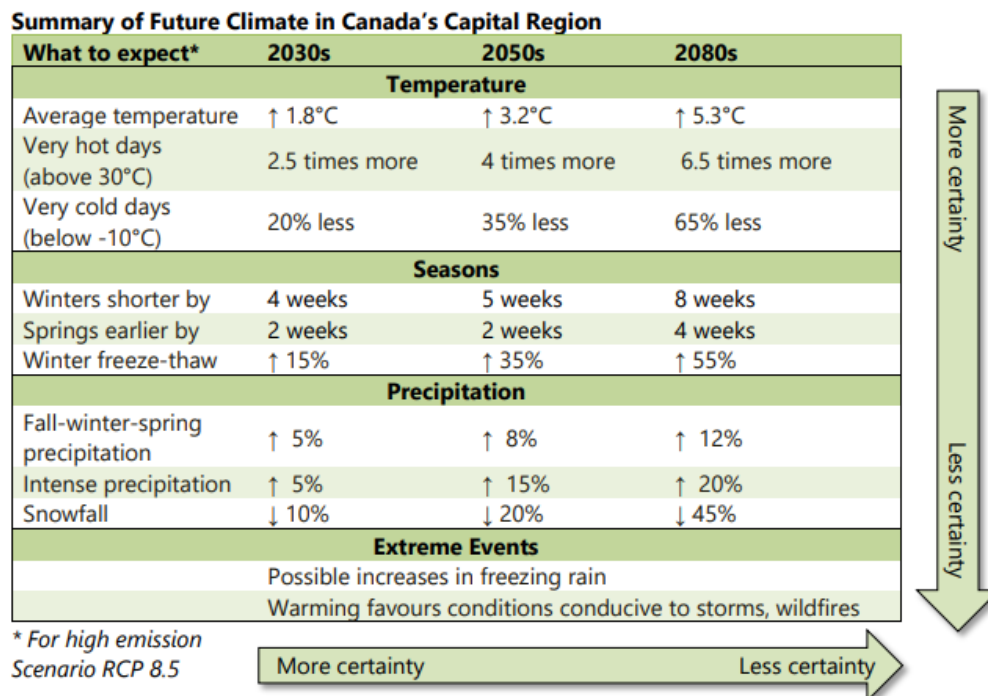

Figure 3-5 Summary of Future Climate in Canada's Capital Region⁷

Implications of the altered weather on buildings includes the following aspects.

- Increased cooling energy consumption (CDD increase).
- Reduced heating energy consumption (HDD decrease).
- Elevated cooling peak loads. While the peak design temperature is not expected to increase significantly from present values, there will be significantly more hours spent at elevated temperatures, meaning that the reliability of cooling systems will need to increase, and the thermal performance of the envelope will need to be designed to mitigate extreme heat events.
- No change to heating peak design loads. While overall the winter will become milder with fewer hours spent at extreme temperatures, the possibility for extreme cold temperatures consistent with today's winter peak design loads will remain, meaning that heating systems will still need to be designed for today's extreme cold events.
- Higher potential for natural ventilation.
- Increased building thermal instability, which can be mitigated through envelope design.
- Increased possibility of rainwater harvesting.

These implications amplify the need for an improved and more resilient envelope which shelters the building occupants from extreme weather conditions, as well as the need for designing climate-resilient energy systems that continue to meet the needs of the community at LBF for the long term.

⁷ [The NCC's Climate Change Adaptation Initiative - National Capital Commission \(ncc-ccn.gc.ca\)](http://ncc-ccn.gc.ca)



3.3 BUILDING ARCHETYPES

Building archetypes 1 and 2, containing a mixture of residential, retail, and office space, were developed to represent the future LBF development as per the MCP.

The planned LBF development will include a mixture of residential, retail, and office space of varying density as appropriate for site conditions. For the purposes of this study, the following two building archetypes have been developed to represent the future built environment.

- **Archetype 1:** Mixed-use residential tower – a 24-storey tower with retail space on the ground floor (two stories) and residential units on the upper stories. Gross floor area of 23,974 m² (257,960 ft²), of which 1,527 m² (6.4%) is retail and 22,447 m² (93.6%) is residential. For the purposes of energy modelling, this building has been modelled on parcel F12.
- **Archetype 2:** Mid-rise towns & apartments – a six-storey residential building with townhomes on the ground floor and apartments on the upper stories. Gross floor area of 4,421 m² (47,570 ft²) which is entirely residential. For the purposes of energy modelling, this building has been modelled on parcel F2.

These two archetypes appropriately represent the planned future built environment as described in the MCP, with two types of residential space: a high-density, high-rise arrangement and a lower-density, low-rise arrangement with retail space representing the non-residential floor area.

3.4 ENERGY MODELLING APPROACH

Detailed building energy models were developed using the Integrated Environmental Solutions Virtual Environment (IES VE) modelling package. IES VE is a suite of integrated analysis tools for the design and optimization of the built environment. The process taken for LBF is summarized briefly below:

- Floor plans for each of the two archetypes were created using AutoCAD. These were transferred to the IES VE ModelIT module which renders them in three dimensions. Adjacent buildings were added to account for shading effects. A detailed solar shading analysis is carried out in the SunCast module that helps in identifying the impact of local and site shading conditions.

Detailed building energy models were developed using the Integrated Environmental Solutions Virtual Environment (IES VE) modelling package, to design and optimize the built environment regarding building systems and site-specific parameters. Potential carbon conservation measures that would meet the net-zero carbon objectives of the MCP were assessed.

- The Apache and ApacheHVAC modules are used to simulate the building HVAC systems based on the system design (e.g., heat pumps, fan coil units) and site-specific parameters such as building occupancy, schedules, set points, internal gains, hot water consumption, envelope performance, etc.



LEBRETON FLATS ZERO CARBON COMMUNITY ENERGY PLAN

Site Conditions and Building Archetypes

- Multiple model iterations are performed to account for differences in building performance targets and design choices until a complete set of models consistent with the final design are available.

Figure 3-6 below shows the archetypes within the LBF development, rendered in the IES VE environment.

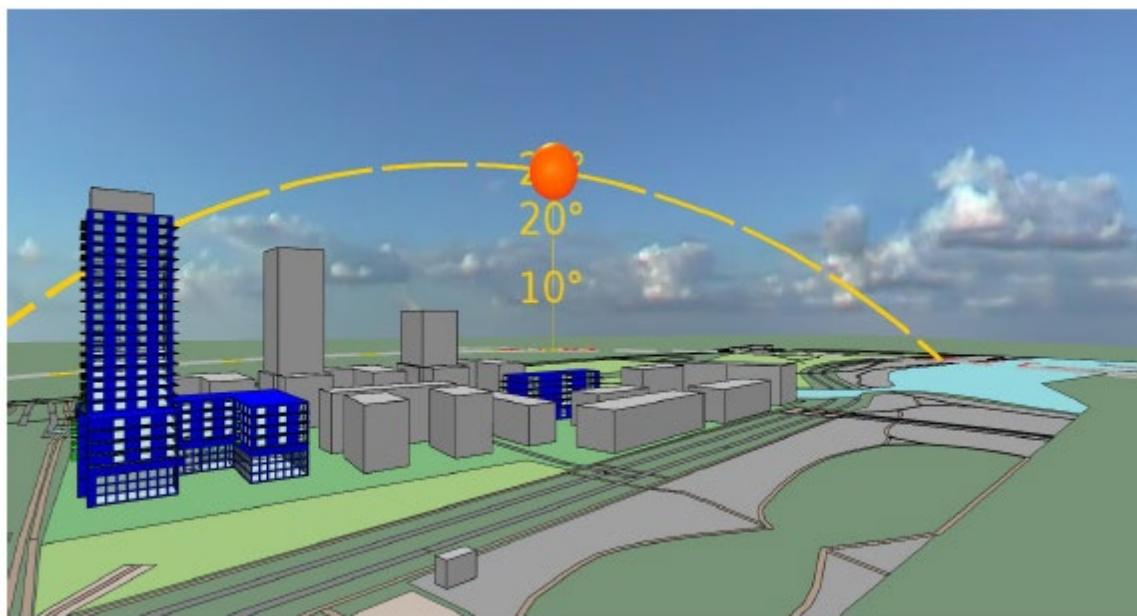



Figure 3-6: Rendering of Building Archetypes with Select Adjacent Buildings, Viewed from the North

3.5 BUILDING PERFORMANCE TARGETS

One of the goals of this study is to identify and determine potential carbon conservation measures, which, when combined as a design option strategy, are suited to meet the net-zero carbon objectives of the MCP. To provide a useful comparison between developments in LBF and developments in other parts of the city, the City of Ottawa’s proposed High-Performance Development Standard (HPDS) has been used to determine the energy performance targets, on the assumption that it will be adopted as the standard during the period in which most development will take place at LBF. Consequently, it provides a fair and reasonable comparison between a development taking place at LBF and a similar development taking place elsewhere in the city at the same time. The targets are summarized in Table 3-1 below.

Table 3-1: Building Performance Targets at a Glance

	Performance Targets	Focus
	Option A: High Performance Development Standard Tier 1 (approx. 25% better than Ontario Building Code, SB-10, Division 3 (2017) or absolute EUI, TEDI, GHGI targets)	Minimum Compliant Design
	Option B: High Performance Development Standard Tier 2 (approx. 50% better than Ontario Building Code, SB-10, Division 3 (2017) or absolute EUI, TEDI, GHGI targets)	High-Performance Target



LEBRETON FLATS ZERO CARBON COMMUNITY ENERGY PLAN

Site Conditions and Building Archetypes

	Performance Targets	Focus
	Option C: Carbon Neutral (Consistent with CaGBC's Zero Carbon Building Standard)	Maximum GHG Emission Reductions

To meet each target, an in-depth investigation of design strategies is required to substantially improve the energy performance, operational costs, and GHG emissions of the proposed buildings. Each design option strategy is evaluated based on the combined energy and GHG performance capability of the selected conservation measures. Each design option strategy is also evaluated from a return on investment (ROI) perspective, using a net present value (NPV) analysis. A different design option strategy will be required to reach each target.

The City of Ottawa's proposed High-Performance Development Standard (HPDS) was used to determine the energy performance targets. The HPDS provides a reasonable comparison between the LBF development and other developments in Ottawa, based on the assumption it will be adopted during LBF development.

The following are more detailed descriptions of the three performance targets presented in Table 3-1 above.

Option A: Design to Meet Minimum Commitments (Baseline Option)

Considering the context of future development in Ottawa, the City of Ottawa's proposed High Performance Development Standard (HPDS) has been used to determine the minimum energy performance target, on the assumption that it will be the adopted standard during the period in which most development will take place at LBF. Essentially, by following the adoption of the HPDS, every development that takes place in the City of Ottawa will be required to meet Tier 1 of the standard and consequently, this becomes the minimum performance (i.e., baseline) option that all other options are compared against. The HPDS allows two pathways to achieving Tier 1: by exceeding the Ontario Building Code, SB-10, Division 3 (2017) by 25%, or by achieving the energy and carbon performance metrics listed in Table 3-2 below.

Table 3-2: HPDS Tier 1 Performance Targets

Building Type	TEUI (kWh/m ² /yr)	TEDI (kWh/m ² /yr)	GHGI (kgCO _{2e} /m ² /yr)
Multi-unit residential (MURB)	142	52	19
Commercial retail	132	52	12

Applying the HPDS Tier 1 benchmarks to the archetypes being modelled for this study, the Tier 1 performance metrics specific to LBF are as shown in Table 3-3 below.

Table 3-3: LBF Specific Tier 1 Performance Targets

Building Type	TEUI (kWh/m ² /yr)	TEDI (kWh/m ² /yr)	GHGI (kgCO _{2e} /m ² /yr)
Archetype 1: Mixed-use residential tower (6.4% retail, 93.6% residential)	141.4	52.0	18.6
Archetype 2: Mid-rise towns & apartments (100% residential)	142.0	52.0	19.0



LEBRETON FLATS ZERO CARBON COMMUNITY ENERGY PLAN

Site Conditions and Building Archetypes

Option B: Design to Meet High Performance Targets

This option can be considered a target for developers following the HPDS who want to achieve significantly better performance than the minimum Tier 1. The HPDS allows two pathways to achieving Tier 2: by exceeding the Ontario Building Code, SB-10, Division 3 (2017) by 50%, or by achieving the energy and carbon performance metrics listed in Table 3-4 below.

Table 3-4: HPDS Tier 2 Performance Targets

Building Type	TEUI (kWh/m ² /yr)	TEDI (kWh/m ² /yr)	GHGI (kgCO ₂ e/m ² /yr)
Multi-unit residential (MURB)	108	33	13
Commercial retail	98	33	7

Applying the HPDS Tier 2 benchmarks to the archetypes being modelled for this study, the Tier 2 performance metrics specific to LBF are as shown in Table 3-5 below.

Table 3-5: LBF Specific Tier 2 Performance Targets

Building Type	TEUI (kWh/m ² /yr)	TEDI (kWh/m ² /yr)	GHGI (kgCO ₂ e/m ² /yr)
Archetype 1: Mixed-use residential tower (6.4% retail, 93.6% residential)	107.4	33.0	12.6
Archetype 2: Mid-rise towns & apartments (100% residential)	108.0	33.0	13.0

Option C: Design to Achieve Maximum GHG Emission Reductions

The objective of Option C is to reduce the annual GHG emissions associated with the buildings as much as possible, with the overall aim for LBF to be a net-zero carbon development. In principle, the NCC is considering the potential to serve the site with thermal energy provided by a district energy system (DES), subject to further analysis. The potential for providing thermal energy with standalone building energy systems will also be investigated as an alternative to a DES. Consequently, the focus of the design at the building level will be to reduce thermal loads, primarily through envelope and ventilation measures, such that the loads will be optimized regardless of how the thermal energy supply is supplied to the buildings. Domestic hot water (DHW) needs may be served by the DES or at the building level, depending on the results of a more detailed DES analysis. Regardless, water efficiency will be key to reducing the carbon associated with DHW heating. Reducing embodied carbon associated with building construction and demolition will also be a priority. Overall, the objective is to prioritize reducing carbon emissions and generating renewable energy on-site over the use of RECs and carbon offsets. The Zero Carbon Building (ZCB) Standard – Design v.2 was used as a reference guide for achieving building-level carbon neutrality.

Table 3-5 below specifies the performance metrics for a net-zero carbon development Option C. ZCB – Design v.2 provides ranges of targets for TEDI based on the climate zone where the building is located and the choice of compliance pathway. Since this study is a pre-feasibility based on archetypes and not a certification exercise, the choice of compliance pathway is irrelevant, and we present the possible ranges



LEBRETON FLATS ZERO CARBON COMMUNITY ENERGY PLAN

Site Conditions and Building Archetypes

for the LBF archetypes. With respect to TEUI, ZCB – Design v.2 only specifies that TEUI be 25% better than an NECB 2017 compliant building. However, in practice, zero-carbon buildings are typically more than 60% better than NECB, and often higher. Additionally, TEUI performance of an NECB MURB can vary significantly due to differences in modelling approaches, as well as a large variation in plug loads, lighting loads, and occupant behavior across similar buildings. Consequently, the TEUI targets are based on typical zero carbon developments for similar building archetypes to the ones selected for this study. Since zero-carbon buildings do not have onsite fossil fuel consumption, the GHGI target was developed from the TEUI target by employing emissions factors for the Ontario electricity grid.

Table 3-6: LBF Specific Net Zero-Carbon Performance Targets

Building Type	TEUI (kWh/m ² /yr)	TEDI (kWh/m ² /yr)	GHGI (kgCO _{2e} /m ² /yr)
Archetype 1: Mixed-use residential tower (6.4% retail, 93.6% residential)	50 - 100	24 - 34	3.0 - 6.0
Archetype 2: Mid-rise towns & apartments (100% residential)	50 - 100	24 - 34	3.0 - 6.0

3.6 NEW ZERO CARBON DISTRICT ENERGY SYSTEM

A detailed pre-feasibility analysis of a new zero carbon district energy system (DES) has been undertaken. This option can be considered to be the benchmark against which all other options for thermal energy supply at LBF will be measured against, including existing DES and high-performance, standalone ZCB HVAC systems.

3.7 EXISTING DISTRICT ENERGY SYSTEMS

Due to its proximity to the LBF site, the potential for connections from LBF to the existing Zibi Community Utility (ZCU) DES and the Energy Services Acquisition Program (ESAP) DES have also been examined.

3.7.1 Zibi Community Utility (ZCU) District Energy System

Zibi is a planned 34-acre development in Ottawa that will provide commercial space, retail space, green space, and residential units for over 5,000 people, as well as 6,000 jobs⁸. Zibi will be served by a low carbon DES currently under development. According to the developer, the Zibi Community Utility (ZCU) is a DES that relies on effluent energy recovery from a local Kruger Products plant for heating and on the Ottawa River for cooling. As an equal partnership between Hydro Ottawa and Zibi, the ZCU DES will provide zero carbon heating and cooling for all Zibi tenants and residents.

All buildings at Zibi will be interconnected through a hydronic loop that will deliver heating and cooling energy generated at the ZCU central plant. The plant will be located in the lower level of a 15-storey residential building at the corner of Rue Eddy and Rue Jos-Montferrand in Gatineau, Quebec. As of January

⁸ <https://zibi.ca/zcu/>



LEBRETON FLATS ZERO CARBON COMMUNITY ENERGY PLAN

Site Conditions and Building Archetypes

2022, the building is in the final fit up phase with eight floors occupied. The plant also provides domestic hot water at a different temperature to the space heating supply by employing a six-pipe configuration for the Ontario side of the distribution system.

Heat will be injected into this plant using low-grade heat from effluents recovered from the neighbouring Kruger Products plant. In peak cooling season, heat will be rejected through chillers into the Ottawa River to efficiently produce chilled water to cool the buildings. For the first three years of the development, temporary plants in Ontario and Quebec provided heating using natural gas. The zero carbon DES became operational at the end of 2021 with the full build out of the Zibi community and DES estimated to be completed by 2032. Although this timeframe has likely been delayed, this is still consistent with the development timeframe for LBF. When completed, the plant is expected to serve 372,000 m² of floor space, with a peak heating capacity of 18 MW and peak cooling capacity of 15.8 MW (4,500 tons).



LEBRETON FLATS ZERO CARBON COMMUNITY ENERGY PLAN

Site Conditions and Building Archetypes

Figure 3-7 below shows the location of Zibi buildings and key DES infrastructure. The close proximity of Zibi to LBF as well as the similarities between the developments indicate that coordination in planning the DES would benefit both sites.

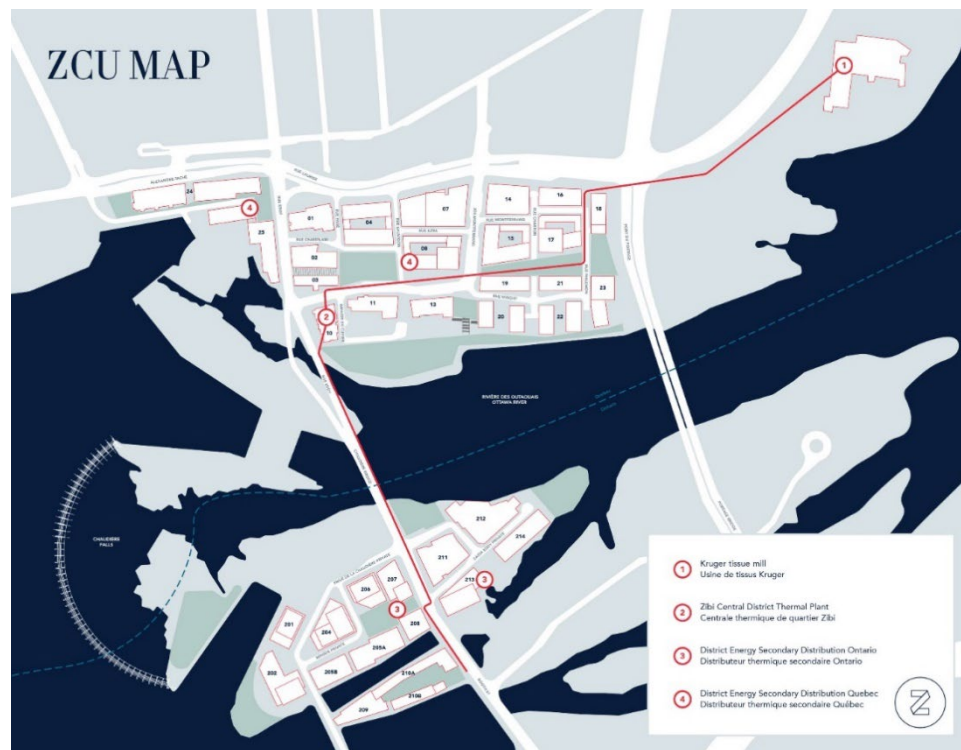

Figure 3-7: ZCU DES Map⁹

3.7.2 Energy Services Acquisition Program (ESAP) District Energy System

The Energy Services Acquisition Program (ESAP) consists of a modernization of existing DES operated by Public Services and Procurement Canada (PSPC) involving five existing central heating and cooling plants constructed between 1916 and 1971. The system currently serves 80 federal and non-federal buildings of approximately 1.6 million m², including the parliament precinct near LBF. ESAP will see the DES designed and constructed between 2020 and 2025 by Innovate Energy, who will also operate the plant until 2055.

⁹ <https://zibi.ca/zcu/>



LEBRETON FLATS ZERO CARBON COMMUNITY ENERGY PLAN

Site Conditions and Building Archetypes

As shown in Figure 3-8 below, ESAP includes many sites in close proximity to LBF, and consideration is being given to expansion and integration with other existing DES in Ottawa, making coordination between the planning of the DES beneficial.

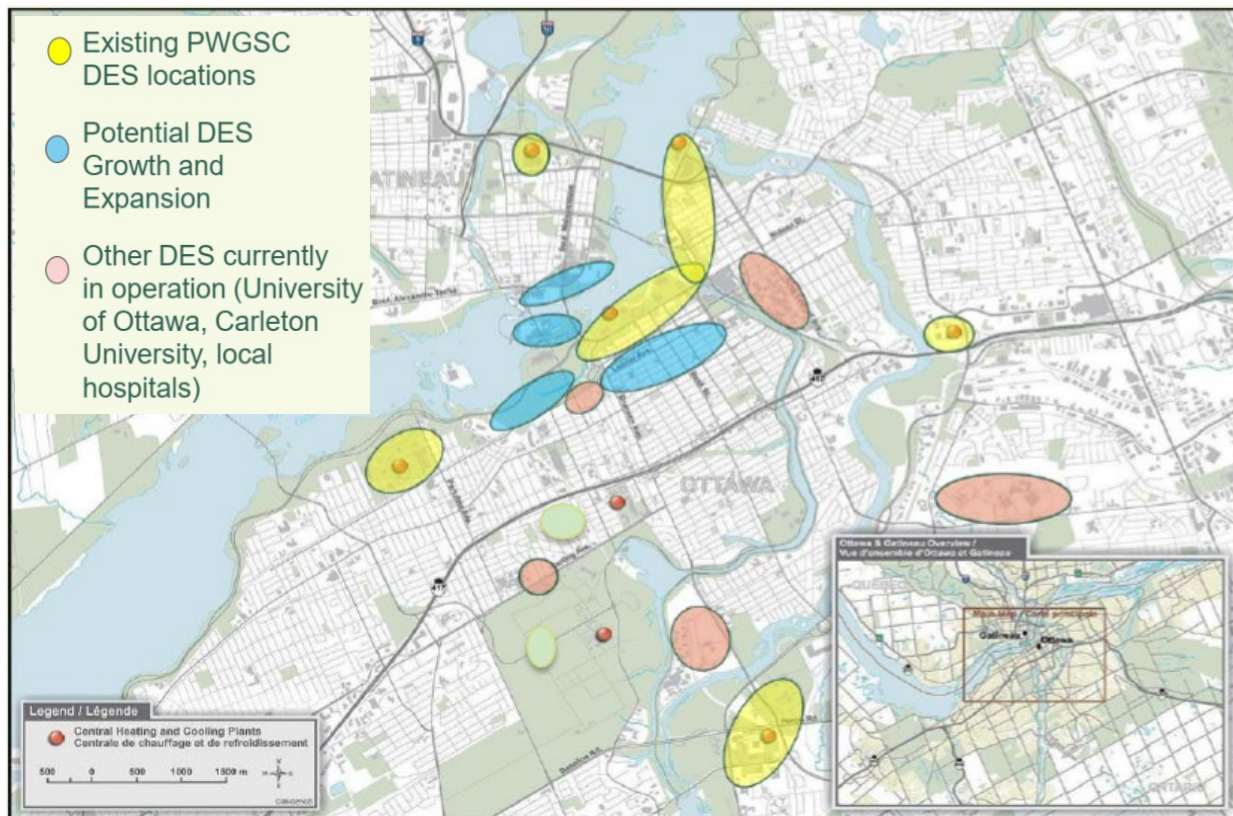

Figure 3-8: ESAP DES Map¹⁰

3.8 ADDITIONAL ENERGY ELEMENTS

The following sections detail the renewable energy systems that were considered for the site. Wind power was not evaluated, since it is challenging to implement in an urban environment. Solar thermal power was not evaluated, since it was considered a lower priority than solar PV.

3.8.1 On-site Electricity Generation and Storage

It is common practice to estimate the potential for on-site renewable energy generation such as building mounted solar photovoltaic (PV) generation when evaluating ZCBs, so it has been included in this study. Integrating storage can potentially enhance the benefits of a generation-only system.

¹⁰ <https://www.districtenergy.org/HigherLogic/System/DownloadDocumentFile.ashx?DocumentFileKey=27fec1eb-3a4d-8258-6f5d-661765734aec>



3.8.2 Off-site Electricity Generation and Storage

Since on-site generation will not likely be able to meet all of the electricity needs of the site, the potential for off-site renewable electricity generation on NCC land outside of LBF will be evaluated. RECs are one option for offsetting the carbon associated with grid electricity used at LBF. Since NCC has land available in the NCR that could be appropriate for renewable electricity generating plants, it could be useful to compare the economic and other benefits of electricity generated on NCC land to RECs purchased on the market.

On-site photovoltaic (PV) generation, thermal generation and storage, process load waste heat recovery, sewer waste heat recovery, and food service (cooking) loads were evaluated for this study.

On-site wind power was not evaluated, since it is challenging to implement in an urban environment. Solar thermal power was also not evaluated since it was considered a lower priority than solar PV.

3.8.3 On-site Thermal Generation and Storage

Similar to electricity generation, there can be benefits to generating and storing thermal energy on-site, particularly for domestic hot water needs.

3.8.4 Process Load Waste Heat Recovery

Various process loads such as commercial refrigeration can be a good source of energy, supplied through waste heat recovery from the process.

3.8.5 Sewer Waste Heat Recovery

Sewer waste heat recovery is a form of energy recovery that extracts energy from sewage (wastewater) and utilises it for process loads. In its simplest form it is very similar to common drain water heat recovery systems where a heat exchanger is used to directly transfer energy from the hotter drain water discharge to the colder domestic water supply. Another method of accomplishing sewer waste heat recovery is to extract sewage from a sewer collector pipe and then use an electric heat pump to transfer energy via a heat exchanger from the low temperature heat in the sewage to a higher temperature fluid which can serve a load such as space heating. This requires more input energy in the form of electricity to run the heat pump, and is also a more complicated and expensive system, but will supply more output energy for the same quantity of waste input energy. An example of such a system is shown in Figure 3-9 below. The figure shows the system in heating mode, but being a heat pump, it also capable of providing cooling.



LEBRETON FLATS ZERO CARBON COMMUNITY ENERGY PLAN

Site Conditions and Building Archetypes

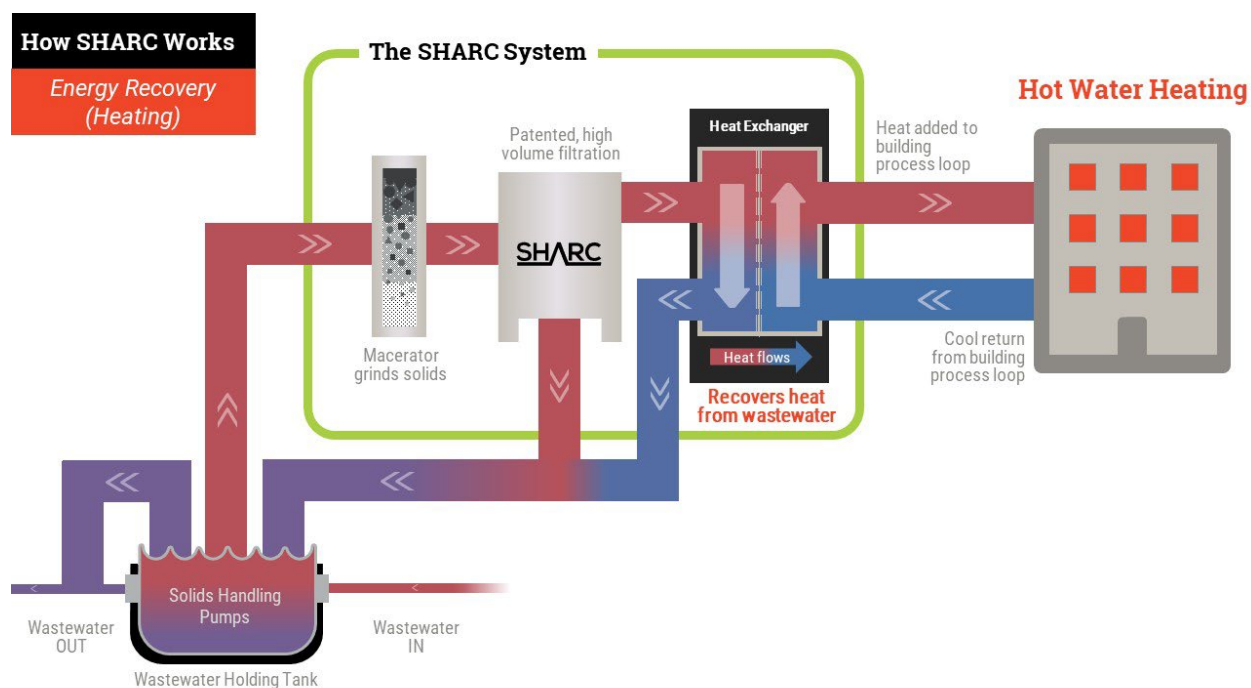

Figure 3-9: SHARC Sewer Heat Recovery System¹¹

The City of Ottawa is currently undertaking an analysis of the potential for waste heat recovery from the City's sewer network, including the West Nepean Collector near LBF. The potential to integrate this waste heat source into the energy supply for LBF will be evaluated.

3.8.6 Food Service (Cooking) Loads

Consistent with best practices for ZCBs, all end uses that are typically served with natural gas in buildings constructed in Ottawa, including space heating, domestic hot water heating, and humidification, have been electrified in the ZCB options (see Section 4.1). However, one end use that may be desirable to continue to supply with natural gas is food service (i.e., cooking) loads, present in restaurants and other commercial food service preparation, as well as possibly some residences, especially luxury options. Many food service professionals have a strong preference for cooking on an open flame, and developers may be reluctant to give up the option to sell residences with gas-fired cooking appliances, which typically command a premium.

Fortunately, the CaGBC's ZCB Design Standard recognizes the benefits of certain forms of renewable natural gas (RNG), also known as biogas, which can either be produced on-site or be purchased from a natural gas utility. Eligible biogas emissions are assigned an emissions factor of zero and do not contribute to direct emissions. Additionally, food service loads are not included in the Zero Carbon Transition Plan,

¹¹ <https://www.sharcenergy.com/products/sharc-wastewater-heat-exchange-system/>



which states that on-site combustion for space heating and hot water must be phased out, even if zero-emissions biofuels are being used.

Consequently, there is an opportunity for food service loads to be served with biogas at LBF, which can satisfy the zero-carbon building mandate in an environmentally responsible manner and benefit developers, tenants, and owners.

3.9 GHG EMISSION FACTORS OF ENERGY SOURCES CONSIDERED FOR LBF

This section summarizes the current and forecasted emissions factors associated with the energy sources that are likely to be considered for LBF. These factors have been used to determine the carbon impacts of the site's energy use. The complete set of emissions factors employed in this study are included in Appendix D.

3.9.1 Ontario Grid Electricity

LBF will require a significant portion of its energy to be provided by grid electricity through a connection to the Ontario grid; therefore, an examination of Ontario's grid emissions factors is appropriate for this study.

The current emissions intensity of Ontario's electricity grid is almost entirely due to the use of natural-gas-fired generating stations, which are used to provide peak capacity and grid ancillary services. As such, Ontario's electricity GHG intensity is highly variable and depends on peak demand at the margins where gas generation is required. In the near term (i.e., until 2030), grid emissions are expected to significantly increase as the nuclear fleet is refurbished, with the existing natural gas plants being the most likely source of replacement generation during this period. Longer term, the grid emissions will be highly dependent on the growth at the margins, particularly if there is significant electrification of space heating loads. This will have the effect of shifting Ontario's grid from peaking in the summer to peaking in the winter, as well as contributing to significant growth in the required generating capacity available during peak periods.

In contrast, the CaGBC ZCB-Design v2 Workbook¹² suggests using a GHG intensity of 20 g/ekWh for the Ontario electrical grid, based on emissions factors sourced from ENERGY STAR Portfolio Manager. It is unclear how ENERGY STAR has arrived at this factor since it is lower than the best performance ever achieved by the Ontario grid and is also substantially lower than other credible forecasts for grid emissions. However, CaGBC's ZCB-Design¹³ guidance does allow for the use of custom emissions factors. For these reasons, Stantec has elected to employ other forecasts that we consider to be more accurate for the purposes of this study.

Stantec gathered GHG emissions factors for Ontario's grid electricity from a variety of reputable sources, including the Independent Electricity System Operator (IESO), Ontario Power Generation (OPG), The Atmospheric Fund (TAF), and Public Services and Procurement Canada (PSPC). These factors are

¹² https://www.cagbc.org/cagbcdocs/zerocarbon/v2/ZCB-Design_v2_Workbook.xlsx

¹³ https://www.cagbc.org/cagbcdocs/zerocarbon/v2/CaGBC_Zero_Carbon_Building_Standard_v2_Design.pdf, p.21



LEBRETON FLATS ZERO CARBON COMMUNITY ENERGY PLAN

Site Conditions and Building Archetypes

summarized in Table 3-7 below. It should be noted that these factors are annual averages based on the predicted generation mix. Marginal emissions factors are likely to be significantly different, depending on the fraction of natural gas generation present in the mix.

Table 3-7: Forecast GHG Emission Intensity of Ontario’s Electrical Grid

Source	Ontario Electricity Emission Factors Forecast (Average)									
	gCO ₂ e/kWh									
	2020	2021	2022	2023	2024	2025	2030	2040	2050	2060
IESO ¹⁴	N/A	N/A	28	39	44	50	72	88	N/A	N/A
OPG ¹⁵	63	54	59	71	76	101	88	91	97	100 ¹⁶
TAF ¹⁷	40	41	45	63	53	82	71	86 ¹⁸	N/A	N/A
PSPC ¹⁹	77	77	92	95	105	107	96	94	94	94

While there are significant differences regarding near-term forecasts, the longer-term forecasts are much more closely aligned, consistent with the expectation that retired nuclear capacity will be replaced with gas-fired generation. Since electricity generation is a provincial mandate, it is difficult to reconcile both short- and longer-term forecasts with the federal government’s plans to reach net-zero carbon emissions by 2050. However, there are expected to be pressures on the Ontario electricity grid to decarbonize in the long term. Consequently, it has been assumed that Ontario’s electricity grid will begin to reduce its GHG intensity in 2055 and achieve net zero emissions by 2075.

The implication of the rising electricity emissions factors for LBF is that any electricity consumption at the site will produce more carbon emissions and will therefore require more carbon offsets to be purchased if that is the chosen mitigation option. There will be no effect on the quantity of RECs required, as these are based on electricity consumption regardless of the grid emissions associated with generation. However, it has been assumed that RECs will not be purchased after 2075 once the grid has achieved net-zero emissions. Rising emissions factors will also reduce the benefits of switching from fossil fuels to grid electricity as the emissions intensity of grid electricity will be closer to that of fossil fuels combusted on site, but the benefits of generating renewable energy offsets will be increased as each unit of electricity generated will displace more carbon emissions from the grid.

3.9.2 Ontario Grid Natural Gas

Natural gas is the most common fuel used for space heating in Ontario, and as such will be modelled as the baseline fuel for space heating in several of the scenarios. Natural gas may also play a role in the zero

¹⁴ <https://www.ieso.ca/en/Sector-Participants/Planning-and-Forecasting/Annual-Planning-Outlook>

¹⁵ PSPC’s Project GHG Options Analysis Methodology.

¹⁶ Forecast for 2055.

¹⁷ <https://taf.ca/publications/a-clearer-view-on-ontarios-emissions-2019/>

¹⁸ Forecast for 2030.

¹⁹ <https://www.opg.com/document/greenhouse-gas-emissions-associated-with-various-methods-of-power-generation-in-ontario/>



LEBRETON FLATS ZERO CARBON COMMUNITY ENERGY PLAN

Site Conditions and Building Archetypes

carbon scenario, depending on the results of the analysis. Natural gas has one of the lowest emissions intensities of fossil fuels, and there are plans to reduce the GHG intensity of Ontario's natural gas supply by adding lower carbon fuels such as renewable natural gas (RNG) and hydrogen to the gas distribution system. For this reason, Stantec has assumed that grid natural gas will continue to be available for the duration of the study, for both the business-as-usual scenarios and the low carbon scenarios. In addition, considering the future role of natural gas fired electricity generation in Ontario, the analysis should ensure that any electrification of natural gas at LBF does not have a negative external impact by shifting gas consumption from site to source emissions.

During consultations with NCC and Stantec, Enbridge indicated that they are modelling scenarios which include maintaining the natural gas distribution system in the long term, where it would need to be a net-zero emissions fuel supply for residential, commercial, and industrial customers. Enbridge reports that preliminary results suggest that such a system is viable with a reduced gas load from current levels, as a result of energy efficiency and electrification as well as blending hydrogen and RNG into the gas supply. Such a conclusion is also supported by studies undertaken by other jurisdictions and utilities. Pilot projects are already underway in Ontario to inject small quantities of RNG and green hydrogen into the grid to test the concept. Enbridge has not formally committed to any targets for reducing the emissions from grid natural gas (i.e., Scope 3 emissions), but have committed to a net zero target for Scope 1 and Scope 2 emissions by 2050. Therefore, for the purposes of this study, Stantec assumes that after 2030, emissions factors for natural gas will begin to ramp down from the current levels of 1,898 g/m³ to net zero by 2075, assuming that the same decarbonization pressures on the electricity supply are applied to the gas supply.

Given the prevalence of natural gas use for serving space heating and DHW loads in MURBs, understanding the evolution of the emissions profile of the natural gas supply is important to estimating the avoided carbon emissions from sustainable development at LBF compared to a business-as-usual scenario, as well as determining what role a net-zero carbon gas supply could play in the sustainable scenarios.

3.9.3 Quebec Grid Electricity

While LBF is not expected to be supplied directly with electricity produced in Quebec, a consideration of Quebec's marginal emissions factors is considered appropriate as the two major DES being considered in the energy mix for LBF, ZCU and ESAP, plan to use Quebec electricity to generate their thermal energy supplies.

According to Hydro Quebec's Sustainability Report 2020²⁰, over 99.6% of electricity generated by Hydro Quebec since 2017 has come from renewable sources, primarily hydroelectric, with the remaining non-renewable fraction primarily generated by thermal plants serving communities that are not connected to the provincial transmission network. Since ZCU and ESAP would be supplied from the transmission network, it is reasonable to consider that this electricity is effectively GHG emissions free. As Hydro Quebec plans

²⁰ <https://www.hydroquebec.com/data/documents-donnees/pdf/sustainability-report.pdf>, p.79.



LEBRETON FLATS ZERO CARBON COMMUNITY ENERGY PLAN

Site Conditions and Building Archetypes

to maintain and expand the hydroelectric fleet and develop new wind and solar generation plants²¹, it is reasonable to assume that this situation will persist long term.

However, it should be noted that determining the marginal emissions from adding electric load directly to Hydro Quebec's winter peak period is complicated by the fact that Hydro Quebec employs a peak load shedding (i.e., demand response) strategy whereby residential and agricultural customers with backup fuel fired heating systems that are subscribed to Rate DT can be switched from electric heating to fuel heating in order to mitigate peak demand loads in the winter²². This means that any future addition of space heating loads to the Quebec grid could result in a larger increase in emissions than would be implied simply by examining the marginal emissions of Hydro Quebec's electricity generation. While all of these emissions would be substantially higher than the emissions associated with electricity generation, they will vary significantly depending on the heating fuel used. According to Hydro Quebec, fuel oil is the most common heating system for participants in Rate DT. However, due to the natural phaseout of fuel oil, and a collaboration between Hydro Quebec and the provincial natural gas utility Énergir to promote Rate DT enrolment²³, this will likely shift to natural gas going forward. Natural gas space heating systems typically have lower emissions factors than fuel oil, but still have significantly higher emissions factors than using Quebec grid electricity for space heating.

3.9.4 Zibi Community Utility (ZCU) District Energy System

According to the developer, the ZCU initially used natural gas as a heating source, resulting in a non-zero emissions intensity. At the end of 2021 the system transitioned to entirely using waste heat recovered from a neighbouring industrial facility, the Kruger paper plant. Consultations with ZCU have confirmed that as a waste heat stream, this energy source can be considered emissions free, since the emissions associated with the fossil fuel consumption will have already been attributed to the industrial facility's emissions inventory. Space cooling will be provided by electric chillers that reject waste heat to the Ottawa River.

All electricity is sourced from Hydro Quebec and is almost exclusively hydroelectric generation. Since the majority of electricity consumed by ZCU will occur in the summer months to provide space cooling, a period when Hydro Quebec has significant excess hydroelectric power generation, for the timeframe relevant to LBF, thermal energy supplied by ZCU can be considered to have very low carbon emissions. However, as noted in Section 3.9.3, adding demand to Quebec's winter peak could result in increased marginal emissions through the load shedding of electric heating loads elsewhere. The impact is expected to be fairly modest for ZCU as this would mostly be pumping energy, but if ZCU is considered further as an energy provider to LBF, a more holistic analysis of the emissions associated with the thermal energy supply including such externalities would be desirable.

²¹ <https://www.hydroquebec.com/sustainable-development/our-approach.html>

²² <https://www.hydroquebec.com/residential/customer-space/rates/rate-dt.html>

²³ <https://www.energir.com/en/about/media/news/partenariat-inedit-hydro-quebec-et-energir/>



LEBRETON FLATS ZERO CARBON COMMUNITY ENERGY PLAN

Site Conditions and Building Archetypes

3.9.5 Energy Services Acquisition Program (ESAP) District Energy System

The ESAP DES is being decarbonized in phases as part of the Federal government’s mandate to achieve carbon neutrality by 2050, with significant reductions achieved by 2025. As such, ESAP is considered a viable option for supplying low carbon thermal energy to LBF, assuming that this level of reductions can be achieved within the stated timeframe.

The emission factors are expected to improve over the two stages of ESAP, with a third and final stage to achieve the complete greening of the DES, as shown in Figure 3-10 below.

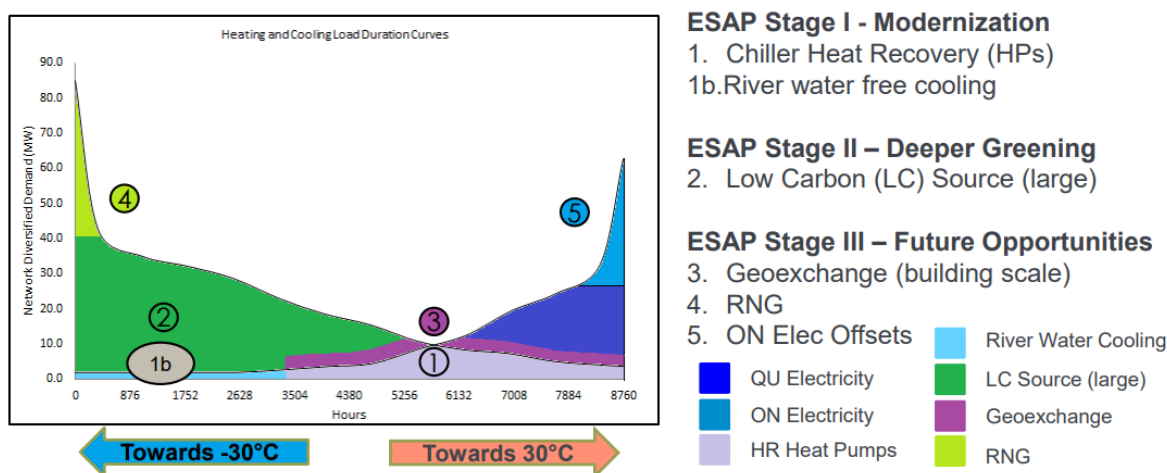

Figure 3-10: ESAP Deeper Greening Efforts and Changes to the Source of Heating and Cooling²⁴

The first stage aims to implement newer technologies from 2017 to 2025, which include converting from steam to low-temperature hot water (LTHW) and upgrading the efficiency of the chiller plant. Starting in 2025, the second stage of the program intends to incorporate a phased replacement of the natural gas boilers with carbon-neutral energy sources, including boilers using renewable natural gas and electricity. Geo-exchange is also being investigated as a possible energy source, with test wells having been drilled at LBF in 2021. The results of these tests were not available in time to be incorporated into this report.

Consultations²⁵ with Public Services and Procurement Canada (PSPC) have provided the following emissions factors appropriate to this study’s timeline, as shown in Table 3-8 below.

²⁴ Districtenergy.org

²⁵ E-mail from Don Grant, Manager, Engagement and Communications, PSPC, August 6, 2021



Table 3-8: Forecast GHG Emission Intensity of ESAP Energy Sources

Fuel Source	GHG Emission Intensity (gCO _{2e} /kWh)
ESAP Heating	
Existing: Steam	294
Stage 1: ESAP Low-Temperature Hot Water (by 2025)	200
Stage 2: ESAP Low-Temperature Hot Water (2026 onwards)	4
ESAP Cooling	
Existing: Chilled Water	23
Stage 1: ESAP Chilled Water (by 2025)	<10
Stage 2: ESAP Chilled Water (2026 onward)	<4

During consultations, PSPC indicated that they would prefer to source electricity from Hydro Quebec where possible, due to the lower cost and lower average emissions factors compared to Ontario electricity. However, as noted in Section 3.9.3, adding demand to Quebec’s winter peak could result in increased marginal emissions through the load shedding of electric heating loads onto fossil fuel heating systems. Consequently, a more holistic analysis of the emissions associated with the proposed decarbonization strategy including such externalities would be desirable.

3.9.6 Emergency Generation

Emergency on-site generation for buildings in Ontario is powered almost exclusively using diesel, and consequently it is highly likely that diesel will be used. However, it is not customary to include emergency generation in the analysis of lifecycle carbon at the design phase, so it has been excluded from the carbon analysis portion of this study. The use of emergency generation for resiliency purposes is considered in other sections of the report.

3.10 ACHIEVING NET-ZERO CARBON EMISSIONS

Since achieving zero carbon emissions will not be feasible at LBF, it will be necessary to pursue an approach of net-zero carbon emissions, which will require various forms of carbon offsets to achieve the required emissions offsets. Consequently, a strategy was developed for how LBF may achieve this in a cost-effective manner while following industry best practices.

The carbon offset market is relatively new and rapidly evolving, with a patchwork of regulations and voluntary mechanisms to trade both renewable energy and other carbon offsets. This section will present some important considerations of carbon offsets and make recommendations to provide a decision-making framework that will support the future development of LBF as a zero-carbon community. Two important concepts to understand with respect to carbon offsets are additionality and persistence.

Additionality refers to whether or not the emissions reductions would have occurred in the absence of a market for offset credits (i.e., whether the emissions reductions are incremental to the business-as-usual scenario). To be considered a High-Quality offset credit, it must be possible to verify the additionality with



LEBRETON FLATS ZERO CARBON COMMUNITY ENERGY PLAN

Site Conditions and Building Archetypes

a high degree of certainty. For example, if a power purchase agreement (PPA) for renewable energy is signed between an energy consumer and a renewable power developer, a clear argument could be made that the additional renewable energy generation is a result of the PPA and the renewable generation would not have been built. Alternatively, if the emissions reductions occur as a result of capturing landfill gas, this link could be less certain, as the management of landfill methane could be mandated by law within that jurisdiction.

Persistence refers to the length of time that the carbon emissions will be offset, analogous to the lifetime of the measure. Similar to additionality, it must be possible to verify persistence with a high degree of certainty to be considered a High-Quality offset credit. For example, the persistence of carbon offsets resulting from renewable energy generation are relatively easy to predict and verify, as they depend on the annual generation and lifetime of the generating station (e.g., solar panels and wind turbines) which can be actively monitored. Conversely, offsets resulting from planting trees would be harder to verify, as it is harder to monitor the status of the trees and predict their lifetime (e.g., the sequestered carbon could be released unintentionally as the result of a wildfire).

Typically, the easier it is to establish a link between the emissions reduction and the offset credits, the higher the quality of the offset. This is a function of both the physical mechanism that offsets the carbon (e.g., using renewable energy instead of fossil fuel generated energy and sequestering carbon in trees), and the ability of the offsets to be monitored and verified for additionality and persistence. Various frameworks exist that support the purchase of High-Quality carbon offsets (e.g., ECOLOGO and Fairtrade).

Similar to the Integrated Design Process (see Section 1.3), there is a generally an agreed-upon strategy for achieving net-zero carbon emissions. This strategy places the highest priority on avoided emissions (e.g., energy efficiency and switching to lower carbon fuels) followed by RECs, with non-RECs offsets being used only where the other options are not available. This approach is taken to mitigate the issues with additionality and persistence noted above. Avoiding emissions entirely avoids the need for offsets and the associated issues of additionality and persistence, while RECs and PPAs can often more effectively address additionality and persistence than non-RECs offsets. In all cases, the use of High-Quality offsets by the market minimizes the issues with validating additionality and persistence. Consequently, this approach will be taken when determining the appropriate carbon reduction strategies for LBF and the cost implications of achieving net-zero emissions. For details regarding cost assumptions for carbon offsets, refer to Section 5.2.4.





4.0 DESIGN OPTION DEVELOPMENT

4.1 BUILDING OPTIONS ANALYSIS

4.1.1 Summary and Overview of Options

This section summarizes how the energy performance targets developed in Section 3.5 were achieved for the two building archetypes, Archetype 1: Mixed-Use High-Rise Building, and Archetype 2: Mid-rise Residential Building. The energy modelling process was conducted for three different performance options as shown in Table 4-1 below, starting from a baseline building that was consistent with Ontario Building Code (OBC) SB-10 requirements.

Table 4-1: Overview of Building Performance Targets

Performance Targets		Focus
	Option A: High Performance Development Standard Tier 1 (approx. 25% better than Ontario Building Code, SB-10, Division 3 (2017) or absolute EUI, TEDI, GHGI targets)	Minimum Compliant Design
	Option B: High Performance Development Standard Tier 2 (approx. 50% better than Ontario Building Code, SB-10, Division 3 (2017) or absolute EUI, TEDI, GHGI targets)	High-Performance Target
	Option C: Carbon Neutral (Consistent with CaGBC's Zero Carbon Building Standard: Design Standard)	Zero Carbon Design

The three performance targets are Option A (Minimum Compliant Design), Option B (High-Performance Design) and Option C (Zero carbon design) are as follows:

- Option A represents the Minimum Performance Criteria for a developer to build at the LBF. The minimum performance criteria here refer to the specific Tier 1 KPI targets set out by the City of Ottawa’s High Performance Development Standard (HPDS).
- Option B represents the High-Performance Design that meets or exceeds the HPDS Tier 2 target KPIs. These KPI metrics are described in Section 3.5 of this report.
- Option C represents a Zero carbon design that is consistent with design guidelines given out by the CaGBC’s Zero Carbon Building (ZCB) Standard. There are no specific KPI targets for this design, but the standard provides a range under which such targets should fall, the balance needing to be achieved with on-site or off-site renewable energy generation and/or carbon offsets.

Essentially, the KPIs provide guidance on how much of the carbon reduction should be achieved through energy efficiency and how much should be achieved through renewable energy generation. Carbon offsets are considered the least desirable approach to achieving net-zero carbon and should be used as a last resort once energy efficiency and renewable generation have been maximized.

As the development at LBF is expected to take approximately 26 years, between 2025 and 2051, it is expected that the OBC, National Energy Code for Buildings (NECB), and the performance targets for the



LEBRETON FLATS ZERO CARBON COMMUNITY ENERGY PLAN

Design Option Development

City's HPDS would undergo several updates. This will likely narrow the performance gap between a carbon neutral design and the minimum acceptable performance criteria for building at LBF, as historically code updates have improved energy performance over time. Therefore, it is encouraged for the developer to go beyond the KPI thresholds set by the HPDS and develop to achieve carbon neutrality. The pathways presented here should be considered the minimum improvements, not the maximum.

This study employs the KPI metrics approach of the HPDS as the performance targets, since they are independent of the code performance of the building and provide a clear target to achieve in terms of building overall energy use, thermal performance, and greenhouse gas emissions.

This study employs the KPI metrics approach as the performance targets, since they are independent of the code performance of the building and provide a clear target to achieve in terms of building overall energy use (i.e., TEUI), thermal performance (i.e., TEDI), and GHG emissions (i.e., greenhouse gas intensity [GHGI]). A developer can still choose the alternative method of meeting the City's HPDS Tier 1 and Tier 2 targets by achieving a certain percentage performance better than code. At the time of this study, the City of Ottawa was still developing the first public

version of the HPDS and so the KPI metrics and percentage reduction targets may be updated from the current values by the time of actual construction at LBF. Regardless, the pathways outlined here are intended to provide useful guidance for improving sustainability.

Option C is a zero-carbon building with no on-site combustion of fossil fuels, consistent with CaGBC's ZCB standard. While options A and B could technically achieve zero carbon using on-site fossil fuel combustion and carbon offsets, this would not be consistent with industry best practices or the ZCB standard. Therefore, additional energy conservation measures (ECMs) were modelled to allow options A and B to be consistent with the ZCB standard. Where relevant, these are noted as "Standard" (i.e., conventional code-compliant design choices) and "Zero Carbon" (i.e., design options consistent with the ZCB standard).

The ECM bundles for each option were selected to achieve the targets in the simplest, most cost-effective manner compared to typical practices for the construction of similar buildings. This approach provides a pathway for a developer who is less familiar with low-carbon design and construction to achieve the specified targets but should not discourage the developer from pursuing alternative strategies towards the design objectives. There are many ways in which the same performance can be achieved, and additional savings can be realized, and achieving higher performance levels than were modelled for this study is encouraged. Additional measures that may apply to LBF are included in Appendix C.

A summary of the building elements is included in Table 4-2 (Archetype 1) and

Table 4-3 (Archetype 2) below.



LEBRETON FLATS ZERO CARBON COMMUNITY ENERGY PLAN

Design Option Development

Table 4-2: Summary of Building Elements – Archetype 1

Building System	Baseline Ontario Building Code (SB-10)	Option A Minimum Compliant Design	Option B High Performance Design	Option C Zero Carbon Design
FENESTRATION-DOOR-WALL RATIO (FDWR)	FDWR of 37% (max. allowable under NECB 2017)	FDWR of 37% (max. allowable under NECB 2017)	FDWR of 37% (max. allowable under NECB 2017)	FDWR of 37% (max. allowable under NECB 2017)
WALLS	R-23	R-23	R-30	R-30
WINDOWS	R-3, Solar heat gain coefficient (SHGC) = 0.4 Double-pane windows w/ metal frame	R-3, SHGC = 0.4 Double-pane windows w/ metal frame	R-5.5, SHGC 0.34 Low-e, triple-pane Argon-filled windows w/ stainless-steel-clad fiberglass frames	R-5.5, SHGC 0.34 Low-e, triple-pane Argon-filled windows w/ stainless-steel-clad fiberglass frames
ROOF	R-36.4	R-36.4	R-50	R-50
INFILTRATION	0.25 l/s·m ² of exterior surface area	0.25 l/s·m ² of exterior surface area	0.225 l/s·m ² of exterior surface area	0.15 l/s·m ² of exterior surface area
INTERIOR LIGHTING	Residential halogen and incandescent, Lighting power density (LPD) of 7.3 W/m ² Retail halogen and fluorescent (LPD 11.4 W/m ²) Occupancy and daylight controls for interior and exterior lighting	Residential halogen and incandescent (LPD 7.3 W/m ²) Retail halogen and fluorescent (LPD 11.4 W/m ²) Occupancy and daylight controls for interior and exterior lighting	Residential LED (LPD 4.8 W/m ²) Retail LED (LPD 9 W/m ²) Occupancy and daylight controls for interior and exterior lighting	Residential LED (LPD 3.65 W/m ²) Retail LED (LPD 9 W/m ²) Occupancy and daylight controls for interior and exterior lighting
PLUG LOADS	Standard-efficiency appliances	Standard-efficiency appliances	Standard-efficiency appliances	High-efficiency appliances and devices (e.g., ENERGY STAR, EnerGuide) Plug load management
HVAC (AIR-SIDE)	In-suite fan coil units Energy Recovery Ventilators (ERV) at 55% sensible effectiveness	In-suite fan coil units ERV at 70% sensible/50% latent effectiveness	In-suite fan coil units ERV at 85% sensible/65% latent effectiveness	In-suite fan coil units ERV at 90% sensible/70% latent effectiveness
HVAC PLANT (WATER-SIDE)	Natural gas boiler, Annual fuel utilization efficiency (AFUE) of 90% Central chiller (system seasonal COP of 2.8)	Standard: natural gas boiler (95% AFUE), central chiller (system seasonal COP of 2.8)	Standard: natural gas boiler (95% AFUE), central chiller (COP 2.8) Zero Carbon: GSHP (system seasonal heating)	GSHP (system seasonal heating COP 2.75, system seasonal cooling COP 2.8)



LEBRETON FLATS ZERO CARBON COMMUNITY ENERGY PLAN

Design Option Development

Building System	Baseline Ontario Building Code (SB-10)	Option A Minimum Compliant Design	Option B High Performance Design	Option C Zero Carbon Design
		Zero Carbon: ground source heat pump (GSHP) (system seasonal heating COP 2.75, system seasonal cooling COP 2.8)	COP 2.75, system seasonal cooling COP 2.8)	
HUMIDIFICATION	Natural gas steam generator (90% AFUE)	Standard: natural gas steam generator (95% AFUE) Zero Carbon: electric steam generator (100% AFUE)	Standard: natural gas steam generator (95% AFUE) Zero Carbon: electric steam generator (100% AFUE)	Electric steam generator (100% AFUE)
WATER EFFICIENCY	Standard-efficiency fixtures	Standard-efficiency fixtures	Standard-efficiency fixtures	Low-flow fixtures High-efficiency appliances
DOMESTIC HOT WATER (DHW)	Natural gas boiler (90% AFUE)	Standard: natural gas boiler (95% AFUE) Zero Carbon: Electric boiler (100% AFUE)	Standard: natural gas boiler (95% AFUE) Zero Carbon: Electric boiler (100% AFUE)	Electric boiler (100% AFUE) Shower drain water heat recovery (DWHR)
CONTROL STRATEGIES	Temperature setback strategies	Temperature setback strategies	Temperature setback strategies	Temperature setback strategies Demand Controlled Ventilation (DCV) Continuous commissioning system
ONSITE RENEWABLE GENERATION	None	None	None	Roof-mounted PV panels (optional)

Table 4-3: Summary of Building Elements – Archetype 2

Building System	Baseline Ontario Building Code (SB-10)	Option A Minimum Compliant Design	Option B High Performance Design	Option C Zero Carbon Design
FENESTRATION-DOOR-WALL RATIO (FDWR)	FDWR of 37% (max. allowable under NECB 2017)	FDWR of 37% (max. allowable under NECB 2017)	FDWR of 37% (max. allowable under NECB 2017)	FDWR of 37% (max. allowable under NECB 2017)
WALLS	R-23	R-23	R-35	R-35
WINDOWS	R-3, SHGC = 0.4	R-3, SHGC = 0.4	R-5.5, SHGC=0.34 Low-e, triple-pane Argon-filled	R-5.5, SHGC=0.34 Low-e, triple-pane Argon-filled



LEBRETON FLATS ZERO CARBON COMMUNITY ENERGY PLAN

Design Option Development

Building System	Baseline Ontario Building Code (SB-10)	Option A Minimum Compliant Design	Option B High Performance Design	Option C Zero Carbon Design
	Double-pane windows w/ metal frame	Double-pane windows w/ metal frame	windows w/ stainless-steel-clad fiberglass frames	windows w/ stainless-steel-clad fiberglass frames
ROOF	R-36.4	R-36.4	R-50	R-50
INFILTRATION	0.25 l/s·m ² of exterior surface area	0.25 l/s·m ² of exterior surface area	0.15 l/s·m ² of exterior surface area	0.15 l/s·m ² of exterior surface area
INTERIOR LIGHTING	Residential halogen and incandescent (LPD 7.3 W/m ²) Occupancy and daylight controls for interior and exterior lighting	Residential LED (LPD 4.8 W/m ²) Occupancy and daylight controls for interior and exterior lighting	Residential LED (LPD 4.8 W/m ²) Occupancy and daylight controls for interior and exterior lighting	Residential LED (LPD 3.65 W/m ²) Occupancy and daylight controls for interior and exterior lighting
PLUG LOADS	Standard-efficiency appliances	Standard-efficiency appliances	Standard-efficiency appliances	High-efficiency appliances and devices (e.g., ENERGY STAR, EnerGuide) Plug load management
HVAC (AIR-SIDE)	In-suite fan coil units ERV at 55% sensible effectiveness	In-suite fan coil units ERV at 85% sensible/65% latent effectiveness	In-suite fan coil units ERV at 90% sensible/70% latent effectiveness	In suite fan coil units ERV at 90% sensible/70% latent effectiveness
HVAC PLANT (WATER-SIDE)	Natural gas boiler (90% AFUE) Central chiller (system seasonal COP of 2.8)	Standard: natural gas boiler (95% AFUE), central chiller (system seasonal COP of 2.8) Zero Carbon: GSHP (system seasonal heating COP 2.75, system seasonal cooling COP 2.8)	Standard: natural gas boiler (95% AFUE), central chiller (system seasonal COP of 2.8) Zero Carbon: GSHP (system seasonal heating COP 2.75, system seasonal cooling COP 2.8)	GSHP (system seasonal heating COP 2.75, system seasonal cooling COP 2.8)
HUMIDIFICATION	Natural gas steam generator (90% AFUE)	Code: natural gas steam generator (95% AFUE) Zero Carbon: electric steam generator (100% AFUE)	Code: natural gas steam generator (95% AFUE) Zero Carbon: electric steam generator (100% AFUE)	Electric steam generator (100% AFUE)
WATER EFFICIENCY	Standard-efficiency fixtures	Standard-efficiency fixtures	Low-flow fixtures	Low-flow fixtures



LEBRETON FLATS ZERO CARBON COMMUNITY ENERGY PLAN

Design Option Development

Building System	Baseline Ontario Building Code (SB-10)	Option A Minimum Compliant Design	Option B High Performance Design	Option C Zero Carbon Design
			High-efficiency appliances	High-efficiency appliances
DOMESTIC HOT WATER (DHW)	Natural gas boiler (90% AFUE)	Standard: natural gas boiler (95% AFUE) Zero Carbon: electric boiler (100% AFUE)	Standard: natural gas boiler (95% AFUE) Zero Carbon: electric boiler (100% AFUE)	Electric boiler (100% AFUE) Shower DWHR
CONTROL STRATEGIES	Temperature setback strategies	Temperature setback strategies	Temperature setback strategies	Temperature setback strategies DCV Continuous commissioning system
ONSITE RENEWABLE GENERATION	None	None	None	Roof-mounted PV panels (optional)

More details regarding the ECMs are provided in the following sections.

4.1.2 Optimizing Envelope Performance

4.1.2.1 Fenestration and Door-to-Wall (FDWR) Ratio



In the building concept, fenestration systems are typically the main source of sunlight and are therefore directly related to the daylighting potential of the building. ASHRAE defines fenestration systems as assemblies and components of windows and openings located on building envelope (ASHRAE Handbook Fundamentals, 2005). While fenestration can be beneficial by providing daylight access, natural ventilation, and visual communication between the interior and exterior, glazed areas that are not properly designed can negatively impact building energy consumption. This is especially true for multi-unit residential buildings (MURBs), where high fenestration-to-wall ratios are common and desirable.

An optimal FDWR ratio ensures good architectural design and helps limit excess solar radiation and air leakage in the building envelope. Windows usually form the weakest link when it comes to energy loss in a building. Increasing the amount of glazing beyond a certain percentage contributes to poor envelope performance, thus increasing the energy needs of the building.

As per the OBC SB-10, the maximum allowable FDWR is approximately 37% for Ottawa, which falls under Climate zone 6A (Cold – Humid, $4,000 < HDD_{18C} \leq 5,000$). For this study, the FDWR has been set at the code recommended value of 37% for the building archetypes across all design options. This limit ensures minimum heat loss in winters and minimum heat gain in summers.



Applicability to Options/Archetypes

Fenestration and FDWR of 37% as per OBC SB-10 Division 3 is used for design options A, B, and C. As both the archetype buildings have a primarily residential occupancy, the same FDWR value is used for both.

4.1.2.2 Wall Thermal Performance

Walls are often the largest section of the building's envelope in contact with the outdoor environment. Hence, in a heating dominated climate such as Ottawa, well insulated walls would reduce the loads of the building which in turn would reduce the capacity of the required heating equipment.



Beyond a certain RSI-/R-Value (thermal resistance) of exterior walls, the impact on energy and carbon savings drops off exponentially. It is crucial to insulate the walls to at least an RSI-4.0 m²-K/W (R-23 ft²-°F-hr/BTU) level for climate zones with cold winters such as Ottawa. It is also equally essential to avoid thermal bridges that penetrate the insulation and impact the overall thermal performance of the wall assemblies. These not only have impacts on energy consumption but can have an adverse effect on the moisture build-up and condensation within the wall assemblies.

Additionally, the National Building Code recognizes the importance of reducing thermal bridging by prescribing continuous insulation in wall assembly requirements. Continuous insulation is defined as insulation that is continuous across all structural members without thermal bridges other than fasteners and service openings. It is installed on the interior, exterior, or is integral to any opaque surface of the building envelope.

Water-Resistive Barrier: Many continuous insulation products can also be used as a weather resistive barrier behind cladding, providing water resistance and thermal performance in one product. It is important to refer to the manufacturer's installation instructions and code compliance data. Alternatively, water-resistive barriers can be separately applied to walls with continuous insulation.

Thermal bridging refers to the condition in a building assembly where unintended heat transfer takes place due to breaks in insulation. Interface details, such as slabs, parapets, and glazing transitions, can be sources of significant heat flow through the building envelope hence the architectural design needs to properly detail transitions between systems to ensure thermal breaks have been incorporated for mitigating thermal bridging.

Wind Pressure Resistance: For code compliance guidance on wind pressure resistance of foam sheathing materials, one should refer to the manufacturer's installation instructions and design data. In some applications, wind pressure resistance is only a matter of temporary construction concern as the product is encompassed or restrained by other materials designed to resist wind pressure once the full assembly is installed.

For proprietary cladding or exterior wall covering systems that include continuous insulation, the specific manufacturer's installation details and instructions should be consulted.



LEBRETON FLATS ZERO CARBON COMMUNITY ENERGY PLAN

Design Option Development

New thermal breaks materials and systems have been developed to reduce thermal bridging in walls. These include thermally broken clip and rail systems, e.g., fiberglass clips and multi-component aluminum clips. Additionally, one could also fasten through the insulation via long screws that can be attached to the backup walls reducing the overall exposure of connections, typically with this method stainless steel fasteners are used due to their considerably higher resistance to heat transfer compared to regular steel and aluminum. Other types of wall assemblies that do not have any thermal bridging include Insulated Metal Panels (IMP), Structural Insulated Panels (SIP) and concrete sandwich panels. Finally, it is best to avoid Z-girts with no thermal breaks.

Prefabricated wall panels offer a good alternative to the existing on-site construction process. These panels are factory-built units produced in an indoor environment, offering economies of scale and are quality tested to ensure design performance. With the envelope being one of the crucial components of a high-performance building, use of prefabricated panels can both save construction time and deliver on the design expectations.

Balconies are another important building detail where design needs to consider providing thermal breaks and ensuring the overall wall performance does not suffer. An extension of the floor slab to form balcony is the worst performing design considering energy implications and needs more a careful thought in designing an assembly that has least thermal bridging. BC Hydro's Building Envelope Thermal Bridging guide is a commonly used industry wide resource for evaluating the thermal performance of a building assembly detail. This study has included balconies in the building design due to their popularity in recently constructed multi-unit residential buildings but has assumed that best practices will be employed to reduce thermal bridging and achieve the stated envelope performance. It is therefore essential that the buildings developed at LeBreton also follow best practices to mitigate thermal bridging.

Applicability to Options/Archetypes

The wall thermal performance to be analyzed will vary from the minimum OBC SB-10 code requirement of RSI-4 m²·K/W (R-23 ft²·°F·hr/BTU) to RSI-6.2 m²·K/W (R-35 ft²·°F·hr/BTU). Archetypes 1 and 2, Option A achieve the code minimum envelope performance. As we move on to more energy efficient design options, there is a need to further push thermal performance beyond code minimum value. For Archetype 1, Options B and C are modelled with an overall resistance of R-30 ft²·°F·hr/BTU and for Archetype 2, Options B and C are modelled with an overall resistance of R-35 ft²·°F·hr/BTU. The difference in choice of the resistance values is based on achieving the target KPI metric for TEUI and TEDI. Note that these values are not merely the insulation values, but the values achieved after detailed thermal bridging calculations, i.e., the overall thermal performance of the wall.

4.1.2.3 Roof Thermal Performance

Current industry standards for additional insulation in commercial built-up roofs typically consists of adding an additional 100 mm to 150 mm of rigid or polyisocyanurate insulation to achieve thermal performance values ranging from RSI-2.8 to RSI-5.3 m²·K/W (R-16 to R-30 ft²·°F·hr/BTU), depending on the thickness and material.



LEBRETON FLATS ZERO CARBON COMMUNITY ENERGY PLAN

Design Option Development

The OBC SB-10 requires higher levels of roof insulation, which for the Ottawa region is given as RSI-6.4 m²·K/W (R-36.4 ft²·°F·hr/BTU). The level of insulation needed on the roof of a building would vary based on the building's shape, however, as a minimum, the roof of the building should meet the OBC SB-10 requirement.

Reflective roofing membrane consideration: Albedo is another name for reflectivity. The albedo of a surface determines how much sunlight will be absorbed and warm the surface compared to another surface that reflects most of the light and does not change temperature. A high albedo means the surface reflects most of the radiation that hits it and absorbs the rest. A low albedo means a surface reflects a small amount of the incoming radiation and absorbs the rest. For instance, fresh snow reflects up to 95% of the incoming radiation and is said to have a high albedo rating.

Light coloured (high albedo) roof and building materials have been used in cooling dominated climates since the early days of building construction. Light coloured roofing materials can be used on commercial and industrial buildings to reduce the solar heat gain upwards of 65%. Lighter colored materials also prove to have longer life expectancy because of reduced absorption of solar radiation. The technology is mature and widely available, but different from the traditional built-up roof with gravel ballast.

Green roofs are also another consideration for cool roof systems but require adequate drainage and possible structural reinforcing when designed.

Applicability to Options/Archetypes

The roof thermal performance to be analyzed will vary from the minimum OBC SB-10 code requirement of RSI-6.4 m²·K/W (R-36.4 ft²·°F·hr/BTU) to RSI-8.8 m²·K/W (R-50 ft²·°F·hr/BTU). For Archetypes 1 and 2, Option A achieve the code minimum envelope performance. As we move on to more energy efficient design options, there is a need to further push thermal performance beyond code minimum value. For both Archetype 1 and 2, Options B and C are modelled with an overall resistance of R-50 ft²·°F·hr/BTU, which represents an approximately 37% improvement over the code minimum value. Note that these values are not merely the insulation values, but the values achieved after detailed thermal bridging calculations, i.e., the overall thermal performance of the roof.

4.1.2.4 Window Performance

From a thermal performance standpoint, windows and fenestration systems are the weakest component of a building envelope. For this reason, the OBC SB-10 limits the amount of glazing and fenestration-door-wall ratios to approximately 37% for Ottawa.



Thermal Performance (Conduction, Solar Radiation, Thermal Break, Comfort)

Glass and glazing selection play a key role in determining the overall building's thermal performance. Fenestration thermal performance requirements must be integrated with the design of the building's heating and cooling systems. Single glazing has poor thermal performance and is suitable only for applications where thermal performance is irrelevant, such as interior applications or installations where interior and exterior temperatures do not vary substantially. Most architectural glazing consists of IGU (Insulated Glazing Units). The thermal performance of insulating glazing depends mainly on the solar energy transmittance through the glazing, the reflectance of the glazing (measured by the shading coefficient, which is the ratio of the solar heat gain through the glazing to the solar heat gain or loss



LEBRETON FLATS ZERO CARBON COMMUNITY ENERGY PLAN

Design Option Development

through a lite of 1/8 in. thick clear glass), the width of the air space, and the material and configuration of the spacer around the perimeter of the unit. Low-emissivity (low-E) coatings limit heat gain through the glazing by reflecting solar energy.

Thermal performance of glazing is expressed by its thermal conductance, which is a measure of air-to-air heat transmission due to thermal conductance and the difference between indoor and outdoor temperature. Conductance is expressed in terms of U-value. A lower U-value indicates reduced heat transfer through the glass. Thermal modeling of specific fenestration assemblies using computer programs such as THERM allow estimation of total U-values for fenestration assemblies and help predict thermal performance.

Over the last twenty years there has been a rapid evolution in technologies to improve the thermal performance of glazing systems. Architectural glass is a highly engineered material bearing little resemblance to the raw material produced by the float process. Today a variety of processes, materials and technologies are integrated with glass to improve its thermal properties including heat-treatment, lamination, metalized coatings, and built up into insulated panels. Thin-film coatings, for example, have significantly improved the thermal performance of glass in the building skin over the past thirty years. Ongoing improvements include interlayer materials for laminating glass, and cavity enhancements of insulating glass units (IGUs) as provided by aerogels and mechanical shading devices built into the cavity. Vacuum glass products are beginning to appear on the market with super insulation properties provided by very shallow, evacuated cavities, promising future multi-ply super-insulating vacuum glass units (VGUs) fitting within the same thin-skin envelope. Highly insulating windows have the potential for substantial energy savings when compared to the existing glazing currently installed.

Fenestrations affect interior daylighting, air tightness, and heat gain/loss, all of which impact mechanical and electrical system demands. Attention needs to be focused on glazing design to ensure the proper balance among heating, cooling, and day lighting is achieved. While electrical lighting energy can be saved through daylight harvesting, the other benefits of windows must be qualitatively weighed against the energy and cost-benefit analysis of increased HVAC energy usage due to larger window area or increased SHGC if implemented to improve access to daylight.

Window-to-wall Ratios

Orientation-sensitive window-to-wall ratios (WWRs) are recommended to help control solar heat gains. In the case of office spaces, careful attention should also be paid to the issue of glare, a visual discomfort usually caused by the difference in relative brightness between a computer screen and a nearby window in direct low-to-medium-angle sun. This response manifests itself through building size, massing, orientation, proportional relationships, and use.

Frame Technology

Frames in windows are an important factor in determine the overall thermal performance of the window. Conductive frames can deteriorate the overall thermal effectiveness of a window as it provides thermal bridging. The following are different frames that may be used to maintain a highly effective thermal performance of the windows.



LEBRETON FLATS ZERO CARBON COMMUNITY ENERGY PLAN

Design Option Development

Typically, fiberglass windows perform much better than some of the other options in terms of thermal performance. The technology also provides the benefit of minimal expansion and contraction. Fiberglass frames reduce the likelihood of unit failure and caulking cracks maintain superior performance with regards to air and water infiltration.

Silica-based aerogels have low thermal conductivity (high R values), are light weight, and can be sandwiched between sheets of glass or plastic to provide “super-insulating” glazing. This glazing can be used in existing and new residential and commercial buildings. Aerogel glazing is now becoming available in the insulation market.

Applicability to Options/Archetypes

The effective thermal performance of the windows analyzed in this study varies from the minimum OBC SB-10 code requirement of $U-1.9 \text{ W/m}^2\cdot\text{K}$ ($R-3 \text{ ft}^2\cdot\text{F}\cdot\text{hr}/\text{BTU}$) to triple glazed $U-1.03 \text{ W/m}^2\cdot\text{K}$ ($R-5.5 \text{ ft}^2\cdot\text{F}\cdot\text{hr}/\text{BTU}$). All the options shall have windows compliant to the minimum OBC SB-10 requirement as a minimum.

In addition, optimizing the window-to-wall ratio of the buildings would contribute to achieving significant energy and carbon reductions. Hence, should be considered as part of the integrated design of all the options.

For Archetype 1 and 2, Option A has the code minimum window performance. As we move on to more energy efficient design options, there is a need to further push window performance beyond the code minimum value. For both Archetypes 1 and 2, Options B and C are modelled with an overall resistance of $R-5.5 \text{ ft}^2\cdot\text{F}\cdot\text{hr}/\text{BTU}$, which represents an approximately 83% improvement over the code minimum value.

Note that installing better windows alone does not contribute to improving the energy performance of the building. Window framing material and window to wall transition details needs to be addressed with equal importance. Designing with adequate thermal breaks is necessary to ensure an overall good performance of the building envelope, including airtightness.

4.1.2.5 Building Airtightness

One area essential to conserving energy is airtightness of the envelope. The more airtight an envelope is, the less air movement between the interior and exterior there is, resulting in less losses of conditioned air, or gains of unconditioned air. Losses and gains must be accommodated by the HVAC system, resulting in oversized inefficient equipment or undersized equipment that is working too hard to maintain system equilibriums, resulting in high energy use and increased maintenance. By reducing air losses, the HVAC equipment can be downsized for additional cost savings.



Compounding these issues is the fact that as the building ages, the air leaks tend to increase as materials and finishes reach the end of their useful service life, increasing the burden on the HVAC systems. Most leaks will happen at junctures in walls and assemblies, windows, doors, and envelope penetrations.



LEBRETON FLATS ZERO CARBON COMMUNITY ENERGY PLAN

Design Option Development

Achieving the desired airtightness levels for a building can be challenging but you can't control what you don't measure. It is recommended to perform two blower door tests, one at the construction documentation stage prior to completing the building, and the other one at the occupancy stage, to ensure an airtight building.

This will require air leakage testing using methods such as blower door tests, under positive and negative pressure, coupled with thermography from the exterior and the interior. Even when the leaks are identified, it may be difficult to address all the leaks without significant and invasive demolition/dismantling of assemblies followed by reconstruction. Hence, it is recommended to have three separate airtightness tests during construction, first when the building envelope is enclosed or at 40% completion, second at 80%

completion stage and third before occupancy. The initial tests would help in identifying issues when it is relatively easy to correct them, and the final test serves as a benchmark for that building.

Controlling air leakage is a major factor in building envelope performance and a lower air leakage rate helps in making the building airtight as well as in achieving higher performance metrics requirements. If it is assumed that all new buildings have a reasonable level of insulation (there are already prescriptive or performance-based standards for insulation R-values, glazing products, etc.), airtightness is the remaining determinant of how energy efficient a building envelope will be. Many of the major organizations that set standards and testing methods for the construction industry, such as ASHRAE, the Air Barrier Association of America (ABAA), and all the building codes have minimum requirements for air sealing recommendations. Other organizations have guidelines, recommendations, or in-house standards for evaluating the performance of whole buildings.

Applicability to Options/Archetypes

The overall air tightness of the building is assumed to improve along with the use of superior envelope components, but additional measures to designed specifically to improve airtightness can also be undertaken. For high performing envelopes, conducting multiple blower door testing prior to the completion of external envelope components is recommended, so that steps to remediate leakage can be undertaken while interior envelope components are still exposed and accessible.

Due to challenges associated with accurately measuring the airtightness of a high rise building we have carefully chosen to model different sets of infiltration rates depending on the option and the type of archetype. Archetypes 1 and 2 have achieved OBC SB-10 code minimum infiltration rate of 0.25 l/s·m² of exterior surface area for Option A, the minimum complaint design. For Option B, Archetype 1 has a 10% lower infiltration rate of 0.225 l/s·m² of exterior surface area from code minimum whereas Archetype 2 has 40% lower infiltration rate of 0.15 l/s·m² of exterior surface area. This is due to fact that Archetype 2 is a smaller building with only residential occupant hence, higher air tightness levels can be achieved with same amount of effort. Option C has 40% improvement in airtightness at 0.15 l/s·m² of exterior surface area from code minimum for both archetypes.



4.1.3 Optimizing Internal Loads

4.1.3.1 Interior Lighting

LED lighting can offer significant energy savings and lower power demand compared to other lighting types. T8 and some T5 fluorescents offer efficacies in the range of 90 lumens/Watt (lum/W). In contrast, LED lighting technology is proving to be able to achieve higher efficacies with commercially available products averaging 125 lum/W and best-in-class products reaching performance levels of 150 lum/W. It is important to note that LED lighting offers a significant untapped potential for further gains since efficacies of 300 lum/W are being achieved in the laboratory. It is possible to speculate that by the mid-2020s, commercial products with efficacies of 170 lum/W may be available. Additionally, LED lights are easier to dim than other types of lighting, allowing for additional energy savings to be achieved through controls.



Additional benefit of LED lighting compared to other types is longer lamp lives reported to range from 50,000 to 100,000 hours, a wider range of color temperatures, and high colour rendering index (CRI).

Applicability to Options/Archetypes

Archetypes 1 and 2, Option A are modelled with a code minimum Lighting Power Density (LPD) based on the building area method. There are primarily two types of areas considering both the archetypes: Residential and Retail, and each have their specific LPD requirements. Incremental performance improvements are reflected moving from Option A to Option C. Option B has 34% better LPD than OBC SB-10 code minimum requirements and Option C has 50% better LPD than code requirements. LED lighting fixtures should be implemented for all spaces in the buildings. A detailed lighting takeoff is needed after design to establish the exact LPD values for each space in the building.

4.1.3.2 Lighting Controls (Occupancy and Daylight Sensors)

Photocell sensors are ceiling-mounted electrical devices that operate in a similar fashion to traditional timer switches in the sense that they can dim or shut off lighting fixtures in certain zones when a predetermined condition is reached. While traditional timer-based systems shut off lights based on occupancy schedules, these sensors measure the natural light of the sun transmitted into perimeter or sky-lit spaces in order to reduce or eliminate artificial light output.



Also, current building codes are now requiring new commercial spaces and common spaces in residential buildings to provide daylighting controls, in an effort to reduce lighting energy in buildings even further than what can simply be achieved by using LED fixtures. Optimized lighting controls that integrate photocell sensors to leverage natural lighting in perimeter spaces offers significant electricity savings and lower operating LPDs compared to traditional lighting control systems that are only timer-based. Furthermore, this can increase occupancy comfort by reducing excessive artificial light and the associated heat gain from the superfluous operation of these fixtures. This can translate to significant cost savings as electricity can frequently be the highest utility cost for typical buildings. Reducing the operating time of light fixtures, regardless of their efficiency, provides the opportunity to reap significant energy savings and extend the life of the fixtures.

LEBRETON FLATS ZERO CARBON COMMUNITY ENERGY PLAN

Design Option Development

Integration of these sensors with the building automation system (BAS), can be expected to reduce energy consumption compared to the SB-10 baseline. The control system can be adjusted to the requirements of each space, alleviating concerns about health and safety, (i.e., lighting levels being too low for security needs). LED fixtures are excellent candidates for this control strategy due to the ease in which they can be dimmed and switched on and off compared to many traditional lighting systems such as fluorescent lighting systems.

Applicability to Options/Archetypes

Due to relative ease of installation, Occupancy and Daylight Sensors are applied to all the options and for both the building archetypes.

4.1.3.3 High Efficiency Appliances and Plug Load Management

Historically, plug loads have been overlooked when undertaking building energy efficiency. But this is changing as plug loads become a much more significant fraction of the overall energy consumption, due to both the absolute growth in plug loads and an increase in their relative share of energy consumption as other significant loads (e.g., heating and lighting) are aggressively reduced.



While OBC SB-10 specifies that the same plug load should be modelled in the baseline and energy efficient cases, it does not explicitly specify that energy efficient appliances should be used. Therefore, there is an energy savings opportunity associated with this measure.

This measure involves specifying that all appliances and devices used in the buildings to meet energy efficiency standards such as ENERGY STAR® or EnerGuide. These include commercial and residential food service (kitchen) equipment, washing machines and dryers, office equipment, and electronics such as televisions. This equipment typically uses 25% less electricity than standard efficiency appliances. Appliances such as washing machines and dishwashers also save a comparable amount of DHW, resulting in further energy savings for the DHW system. This applies to both electric and natural-gas-fired appliances, which could be relevant if renewable natural gas (RNG or biogas) is used for food service equipment.

There are many plug load management strategies that can be employed depending on the space type and equipment being controlled. Options included occupancy-based controls for office spaces, smart power strips to control plug load in residential suites, and occupancy sensor controls for the vending machines (separate or integrated) in retail or residential building common areas.

Applicability to Options/Archetypes

Archetypes 1 and 2, options A and B use standard-efficiency equipment. Option C is equipped with high-efficiency appliances and plug load management. We have decided not to claim additional savings for this study, but this measure is relatively easy to implement with quick payback. Therefore, a developer can choose to include high-efficiency equipment with plug load management strategy as standard, irrespective of the energy-efficiency target. Additionally, the strategies to achieve these savings will vary significantly depending on what the developer, owner, and/or operator of the building has control over. Engaging with



building occupants will likely be necessary to implement the measures and achieve full benefits, especially in cases where the occupants will own the appliances.

Note Regarding Thermal Energy Demand Intensity (TEDI)

Another key consideration are the interactive effects between the internal gains (i.e., heat emitted from the lights and plug loads) and the space heating delivered by the HVAC system. Using high-efficiency LED lighting, appliances, and controls increases the amount of space heating that must be supplied by the HVAC system. This negatively impacts TEDI, though overall energy use will likely be lower. This limitation of the TEDI metric only considers thermal heating energy needs. It does not consider that the HVAC system will likely use less energy to make up additional heating loads than will be saved from reduced lighting and plug loads. This is because internal heat gains have an equivalent COP of 1, whereas even the worst-performing electric heating system would have a COP of 1, and a heat pump would have a COP greater than 2.5. This also does not consider the additional burden of the heat gains on the cooling system. Therefore, lighting loads should be optimized regardless of their impact on TEDI. Alternative measures to improve TEDI such as improved envelope performance and reduced ventilation energy should be considered instead of relying on plug load and lighting heat gains.

4.1.4 HVAC – Air Side

4.1.4.1 Dedicated Outside Air System and Fan Coil Units with Energy Recovery

A key consideration to achieving effective ventilation with a central HVAC system, such as a multizone variable air volume (VAV) system, is that the sensible loads may not have a linear correlation with ventilation requirements on a zone-by-zone basis. One limitation of central VAV systems is that a system-wide rise in outdoor air (OA) can be triggered by increased ventilation requirements in critical zones that require additional OA to comply with ASHRAE 62.1. However, other zones served by the central system may have stable sensible loads and ventilation requirements. This can result in overventilation of some spaces, which consumes significant net energy due to the requirement of conditioning additional outside air.



LEBRETON FLATS ZERO CARBON COMMUNITY ENERGY PLAN

Design Option Development

VAV and constant air volume (CAV) systems are typically sized to meet the entire space heating and cooling loads associated with central AHUs. Dedicated outdoor air systems (DOAS) and terminal fan coil units decouple the sensible and latent space loads, such that fan coil units address the space sensible loads while the DOAS mitigates and the sensible and latent loads for the outside air only. The advantage of this design over traditional all air systems is the potential for significant fan energy savings which is typically a large end-use for most buildings. This is accomplished with the understanding that the DOAS fan is only sized to supply the volume of OA necessary to meet indoor air quality (IAQ) requirements, and that there is only a small amount of fan power required at the fan coils. This results in a fan power reduction of approximately 50%.

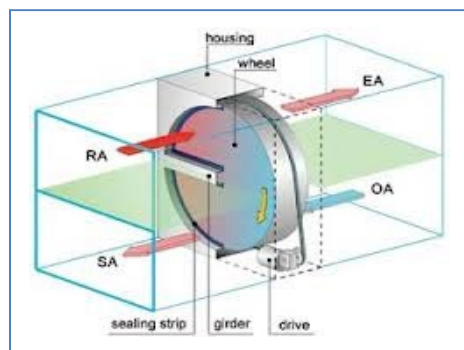

Figure 4-1: Air-to-Air Energy Recovery

Source: <https://www.researchgate.net/>

Energy Recovery: Air-to-air energy recovery is the process of recovering energy, (i.e., both sensible and latent components in contrast to heat recovery which only recovers sensible energy), from one air stream and transferring it to another air stream. In most applications, this entails recovering energy from building exhaust air to precondition incoming outside air for ventilation. It is a key design consideration for ventilation systems, to limit energy consumption and operation costs in buildings that require large volumes of outside air.

Energy recovery technology includes plate heat exchangers, heat wheels, heat pipes, and runaround loops. Each offers a different level of performance or heat recovery effectiveness, typically ranging from 35% effectiveness for runaround loops to 75% for heat wheels.

High-efficiency ERVs can achieve sensible effectiveness of 85% and higher. Sensible and latent heat can be recovered depending on the type of technology. Plate type, heat pipes, and runaround loops can only recover sensible heat, while heat wheels can recover both sensible and latent heat.

Applicability to Options/Archetypes

Fan coils with DOAS are well suited for the buildings under consideration compared to more conventional all-air distribution systems. Therefore, fan coils with DOAS have been implemented in all spaces regardless of the space usage and provide significant energy and carbon savings compared to conventional all-air systems. This HVAC system is used for all options and building archetypes, with only the ERV effectiveness being varied across the scenarios. A wide range of products are available in the market that can be integrated into this HVAC system to achieve the desired performance goals. The sensible effectiveness of the ERVs modelled in this analysis varies from 70% to 90% and the latent effectiveness of the ERVs varies from 50% to 70%.

4.1.4.2 Humidification

The importance of maintaining relative humidity in occupied spaces has become crucial, especially considering the role it plays in reducing the spread of airborne infectious diseases. Relative humidity levels between 30% and 60% are considered ideal for occupant



LEBRETON FLATS ZERO CARBON COMMUNITY ENERGY PLAN

Design Option Development

comfort, and this is also the range in which the growth and spread of viruses is minimized. Historically it has not been common to provide humidification in MURBs in Ontario. However, due to the increased focus on improved IAQ and occupant comfort, health, and wellbeing, it has been included in this analysis as there is a higher probability that it will be included in the buildings developed at LBF.

Humidification is often provided with a natural gas or electric boiler-based steam generation system. Electric boilers are therefore a good option to reduce GHG emissions associated with this end use, and simple to install and operate.

Applicability to Options/Archetypes

The humidification is split into two design scenarios, the standard design and the zero carbon design. The standard design uses a natural gas-based steam generated having efficiency of 95% and the low carbon design uses an electric steam generator with 100% efficiency.

4.1.5 HVAC – Plant Side

Two distinct options have been evaluated for the plant side HVAC systems, standard and zero carbon. The standard design employs more typical strategies with energy performance improvements to achieve the tiered targets set by the City's HPDS (refer to options A and B). The zero carbon design removes on-site fossil fuel combustion from the heating system.



4.1.5.1 Standard Heating and Cooling Systems

This pathway analyzes the more traditional case of using a natural gas-fired boiler as the heating system and a central water-cooled chiller as the cooling system.

Efficiencies of condensing natural gas boilers have evolved over the last few decades and now it is common to find condensing units delivering efficiencies above 95% at peak operating conditions. Similarly, water cooled chiller technology has evolved over the years and it is common to find units delivering a COP of at least 4.2 at peak conditions and an Integrated Part Load Value (IPLV) of at least 5.2.

Applicability to Options/Archetypes

This analysis employs a natural gas condensing boiler with an AFUE of 95% and a chiller with a COP of 2.8 (i.e., code minimum) for the analysis of options A and B. This is a conservative approach chosen to demonstrate the pathway to achieving the target benchmarks with minimal equipment upgrades. A developer will therefore have the opportunity to easily go above and beyond the equipment performance parameters used in this study.

4.1.5.2 Zero Carbon Heating and Cooling Systems

The zero carbon design uses ground source heat pumps (GSHPs) coupled with a vertical, closed-loop geo-exchange system to deliver its heating and cooling needs. The objective of this design is to avoid burning fossil fuel for the purpose of meeting the heating requirements of the buildings. A GSHP system was



LEBRETON FLATS ZERO CARBON COMMUNITY ENERGY PLAN

Design Option Development

selected as it provides the most direct comparison with the zero carbon DES options described in Section 4.2.

A geo-exchange system transfers thermal energy between the conditioned space and the earth using GSHPs and a geo-exchange loop. This allows the earth's mass to be employed as a thermal reservoir (i.e., as a heat sink during the summer and a heat source during the winter). Because the ground temperature remains relatively stable year-round at an average of approximately 13°C (55°F), GSHP systems are generally more efficient than conventional heating systems and some cooling systems, although generally not as efficient as the best variable speed centrifugal chillers.

A GSHP system is comprised of three major system components: a heat pump, an earth connection system, and an interior heating and cooling distribution system.

Heat Pumps and Distribution

The heat pump transfers the energy between the heating and cooling distribution system to the earth connection system. Through the earth connection system, the refrigerant in the core of the heat pump loop undergoes a vapor-compression refrigeration cycle. The heat pump system can be based on two types of heat pumps: water-to-air heat pumps and water-to-water heat pumps. Several configurations would likely be most applicable to LBF, considering what is typically employed in MURB designs. Two popular configurations include the following:

- Supply in-suite fan coil units through a hydronic loop served by a central, water-to-water heat pump connected to the geo-exchange loop
- Install distributed water-to-air heat pumps in each suite, supplied from the geo-exchange system through a building hydronic loop

Earth Connection System

The earth connection system (also known as geo-exchange system or ground loop) is used to transfer the energy between the GSHPs and the earth. There are three common types of earth connection systems, as follows:

- Ground-coupled (typically a closed-loop system)
- Groundwater loop (open-loop system)
- Surface water loop (open-loop system)

The closed loop systems can be configured as either vertical or horizontal loops.

For horizontal installations, the pipes are installed below the frost line, generally at a depth of less than 3 meters. This installation is often less expensive than vertical loops but requires a larger site. Due the requirements for large areas, horizontal installations are typically limited to small buildings or campus-type installations.

For vertical installations, boreholes are normally drilled at depths of 35 to 150 meters (115 to 500 ft). The boreholes are generally spaced 4 to 6 meters (12 to 20 ft) apart and the spacing depends on the thermal



LEBRETON FLATS ZERO CARBON COMMUNITY ENERGY PLAN

Design Option Development

conductivity of the substrate, with tighter spacing possible when drilling in sandstone, shale and/or limestone. The capacity of vertical loops is about 15 to 20 m/kW (175 to 230 ft/ton) of buried vertical pipe.

More detailed geotechnical analysis would need to be undertaken to determine the soil characteristics before detailed analysis and design of the borefield could take place. However, we can assume from the density of the development and the availability of land that only a vertical loop configuration would be applicable at LBF.

The geo-exchange system would not likely be sized to meet 100% of the peak heating and cooling loads but would instead be sized to optimize the duty cycle of the GSHPs. Additional peak heating loads could be met with electric boilers, and additional peak cooling loads could be met with water cooled chillers. Thermal energy storage systems could also be used. The choice and capacity of auxiliary system would depend on the results of the detailed design that would be undertaken by the building developer closer to project implementation.

Applicability to Options/Archetypes

A zero carbon design case is analyzed for options A, B, and C. The GSHP system has an assumed heating COP of 2.75 and an assumed cooling COP of 2.8, consistent with the minimum performance specified by building code.

4.1.6 Domestic Hot Water

Two distinct options have been evaluated for the DHW systems, standard and zero carbon. The standard design employs more typical strategies with energy performance improvements to achieve the tiered targets set by the City's HPDS (refer to options A and B). The zero carbon design removes on-site fossil fuel combustion from the heating system.



4.1.6.1 Water Efficiency

Similar to the heating and cooling loads, the demands on the DHW system should be minimized through water efficiency strategies, before implementing higher-performance and lower-carbon water heating equipment. Water efficiency measures always reduce water consumption, and where hot water consumption specifically is reduced, further energy savings are achieved from the reduced water heating load.

The minimum standards for water efficiency specified by OBC SB-10 are superior to the performance of many products available on the market, including faucet aerators, showerheads, and toilets. However, there is still significant room for improvement in water efficiency.

Additionally, ENERGY STAR rated dishwashers and washing machines can significantly reduce water consumption in addition to providing energy savings.



LEBRETON FLATS ZERO CARBON COMMUNITY ENERGY PLAN

Design Option Development

Applicability to Options/Archetypes

Water efficiency measures were modeled for Option C in both archetypes, as well as Option B in Archetype 2. However, since these measures are cheap and easy to implement, especially at the time of new construction, they should be considered the default option in all construction.

4.1.6.2 Standard Water Heating Systems

Conventionally, service water heating systems use gas-fired boilers to deliver the hot water needed for occupant use in buildings. These boilers can be condensing or non-condensing. The current version of the OBC SB-10 requires hot water heating equipment to have an efficiency of at least 90%, which suggests using the higher-efficiency condensing boiler. Due to recent development in technology, it not uncommon to find a condensing boiler delivering efficiencies greater than 95%.

Applicability to Options/Archetypes

This analysis employs a natural gas condensing boiler having an AFUE of 95% for options A and B for both archetypes.

4.1.6.3 Zero Carbon Water Heating Systems

A zero carbon design for a DHW system aims to avoid GHG emissions, due to the use of fossil fuel-fired equipment. The relatively low emissions factors of Ontario's electricity grid mean that electrifying the DHW heating systems will significantly reduce carbon emissions, even without improving the efficiency. Electric options range from electric resistance heating at 100% efficiency to heat pumps with a COP of approximately two (i.e., 200% AFUE). While many DHW heat pump options are available in the marketplace, they are not currently a widely used technology.

On-site generation such as solar thermal DHW is also an option, but in Ontario's climate, it is typically sized to offset heating loads rather than to completely serve them. Solar thermal DHW has not been considered for this site, due to the limited availability of roof space at LBF and the likelihood that any space used for on-site generation will be allocated to solar PV.

Applicability to Options/Archetypes

We have chosen to use an electric resistance heating system for all the site-specific options and archetypes in our analysis because this represents the simplest approach and worst-case option for energy performance. Developers have the option to pursue higher-performing options, but they are not being relied upon.



4.1.6.4 Drain Water Heat Recovery

Drain-water heat recovery systems (DWHR) can recover heat from the hot water used in showers, bathtubs, sinks, dishwashers, and washing machines. Simultaneous flows of cold water and heated drain water offers the best potential for heat recovery. For LBF, this will be most common in the in-suite showers, as shown in Figure 4-2 below²⁶.

Drain water flows through a spiral copper tube at the bottom of the heat storage tank. This warms the tank water, which rises to the top. Water heater intake water is preheated by circulating through a coil at the top of the tank. DHWR can potentially reduce hot water requirements for showering by 40% to 60% and can therefore significantly reduce the overall DHW heating energy, considering how large a load showers are in MURBs.

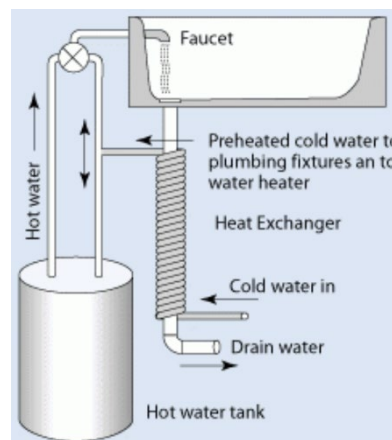

Figure 4-2: Drain Water Heat Recovery System

Applicability to Options/Archetypes

This technology is relatively easy to install during new construction and delivers quick payback on the initial investment. We have implemented the DWHR system for the carbon-neutral design Option C, but it is encouraged for a developer to take advantage of this technology irrespective of the targeted performance metrics, especially since this technology is rarely economical to pursue in a retrofit scenario.

4.1.7 Control Strategies

4.1.7.1 Smart Controls

Building Automation Systems (BAS) have continuously evolved since their introduction in the mid-1980s. They now include advanced workstations with cloud connectivity, enabling remote access from mobile devices. Although suppliers have routinely touted the ability of BAS control systems to offer self-tuning algorithms such as optimum start-stop control sequences, the real-world performance has fallen short of expectations and potential capabilities, partly due to the need for the proper commissioning and maintenance of such systems, as well as proper operator training.

Recognizing this disconnect, approximately 10 years ago controls vendors began to review the next generation of BAS software that would incorporate automatic data analysis, machine learning, and self-tuning algorithms using expert systems. The field of data analytics is growing at a rapid pace, and the HVAC systems industry is expected to be well served by advanced controls strategies in the near future. The main objective of such systems is to perform continuous controls optimization through correction of control loops

²⁶ [Drain-Water Heat Recovery | Department of Energy](#)



LEBRETON FLATS ZERO CARBON COMMUNITY ENERGY PLAN

Design Option Development

that operate below their optimum parameters. These expert systems are known under various names including fault detection systems and diagnostic agents for building optimization.

Advanced building design diagnostics (ABDS) typically takes the form of an additional layer of software added to the operator workstation (OWS) of a BAS which is indiscernible to the operator. These systems can also operate to reduce the electrical peak which can reduce overall operating costs for the building. However, the associated savings can be challenging to quantify or guarantee prior to implementation and verification of the ADBS systems.

Costs have been dropping rapidly in recent years, resulting in smaller and more distributed systems such as smart home thermostats which are cheap enough to install in a single MURB suite and still offer most of the functionality of a large and distributed building-wide BAS.

Typical savings can range from 5 to 30%, depending on how well or poorly a building is operating without the system.

Applicability to Options/Archetypes

This technology is rapidly evolving and, as such, will be an excellent candidate for use at LBF given the development timelines. For the purpose of this study, we have chosen to implement ABDS for Option C. Note that advanced commissioning process needs to be in place to ensure the operation of these systems as intended.

4.1.7.2 Demand Control Ventilation (DCV)

Demand controlled ventilation (DCV) is a control strategy that varies the amount of outdoor air (OA) introduced through air handling equipment by monitoring CO₂ levels in the occupied spaces in a building. Since people breathe out CO₂, it is a reliable way to measure occupancy. A DCV strategy essentially ensures that only the minimum required OA is introduced into the space. It also ensures that more OA is introduced when needed (i.e., economizer control), providing an overall improvement in indoor air quality (IAQ). This presents an opportunity for substantial energy savings, since conditioning outside air in Ottawa during peak heating and cooling conditions, with outdoor air temperatures of -25°C or +30°C respectively, can require substantial energy inputs. By reducing the outside air supplied to an unoccupied space, a building can become much closer to meeting its energy and GHG targets. Ideally, a properly implemented DCV strategy relies on zone level CO₂ sensors installed in all spaces.



Applicability to Options/Archetypes

The DCV strategy is assumed to be included in options B and C and bundled with other technologies, as part of a whole building program that would also include smart controls. DCV is mutually exclusive with recirculating air systems (i.e., VAV systems), as the fresh air critical zone requirement may override the DCV controllers, resulting in no energy savings being achieved.

4.1.8 Renewables

4.1.8.1 Rooftop Photovoltaics (PVs)



The integration of roof-mounted photovoltaic (PV) technology can offset both the on-site energy use and GHG emissions. The PV panels convert sunlight (i.e., photons) directly into usable electricity using semiconductors, through a quantum mechanical process referred to as the PV Effect. Solar cells produce direct current (DC) electricity from sunlight which can be used to power equipment directly or to recharge a battery, allowing the energy to be stored for later use. On-site PV installations frequently include inverters which convert the DC electricity generated by the PV panels into alternating current (AC) electricity, which is generally more compatible with the building electrical system but results in additional losses from the system. On-site PV panels can also be connected to the grid to make use of the generated energy more efficiently.

There are different types of PV panels, including the following:

- Monocrystalline
- Polycrystalline
- Thin-film
- String-ribbon
- Amorphous silicon
- Cadmium telluride
- Copper indium gallium selenide solar cells
- Building-integrated

Each type of solar cell has advantages and disadvantages, which include ranges of efficiency, efficiency of output per panel area, cost, and waste produced during manufacturing. The chosen PV technology for this study is polycrystalline silicone. It may not offer the highest efficiency but is considered among the more cost-effective solutions. Newer-generation polycrystalline solar cells have typical efficiencies in the range of 13% to 22%.

Roof PV systems are typically anchored using ballasts. The solar layout recommended is a function of row spacing, panel shading, and angle of inclination. With a higher angle of inclination, the row spacing must increase to prevent inter-row shading, which reduces the PV density on the roof. Additionally, the higher a panel is raised, the higher the wind loading of the panel, which would require additional ballasting. Consequently, a heavier load would be placed on the roof, and this needs to be appropriately accounted for in the structural design.



LEBRETON FLATS ZERO CARBON COMMUNITY ENERGY PLAN

Design Option Development

Applicability to Options/Archetypes

The sustainable design approach encourages maximizing load reduction, high-efficiency equipment, and control strategies before pursuing on-site renewable generation, and we have followed this philosophy. Consequently, the previously described ECMs are able to achieve the ZCB standard without the use of on-site solar PV generation. This is desirable, as the roof space is limited at LBF, and it may be more desirable to use it for other purposes such as rooftop gardens or greenspace. However, we modelled the maximum on-site generation potential to provide insights into how much grid electricity can be offset using on-site generation and how much renewable electricity would need to be generated off-site to achieve a 100% renewables supply for the site. Refer to Section 4.6.1 for more details. It has been assumed that, at most, 60% of the roof area of the LBF development could be used for solar PV.

4.1.9 Building Level Summary

The following section summarizes the results of the building-level energy and carbon analysis for the two archetypes. A comparison is made between the building results for options A, B, and C against the building performance targets specified in Section 3.5. For options A and B, only the standard design options (as described in Section 4.1.1) are included (i.e., not the zero-carbon versions). Including the zero-carbon (i.e., all-electric) equipment would further improve the results, as the electric equipment is more efficient than the natural-gas-fired equipment in all cases and has a lower carbon intensity when using Ontario grid electricity. For Option C, the effect of the plant-side HVAC system has not been included. This is in order to isolate the effect of load reduction only, which would represent a worst-case scenario (i.e., a COP of one). The superior performance of renewable HVAC systems (i.e., a COP greater than one) would further improve the energy performance. These systems could be part of the building infrastructure or a separate DES and would achieve the same outcome.

Figure 4-3 below summarizes the results of the Thermal Energy Use Intensity (TEUI), the Thermal Energy Demand Intensity (TEDI), and the Greenhouse Gas Emissions Intensity (GHGI) for Archetype 1. It can be seen that the selected ECM bundle summarized in Section 4.1.1 is sufficient to achieve the target KPIs. An important finding of the analysis was that TEDI is the parameter that governs whether the target is met, since once the TEDI target is achieved, the TEUI target is exceeded without any additional measures being required.



LEBRETON FLATS ZERO CARBON COMMUNITY ENERGY PLAN

Design Option Development

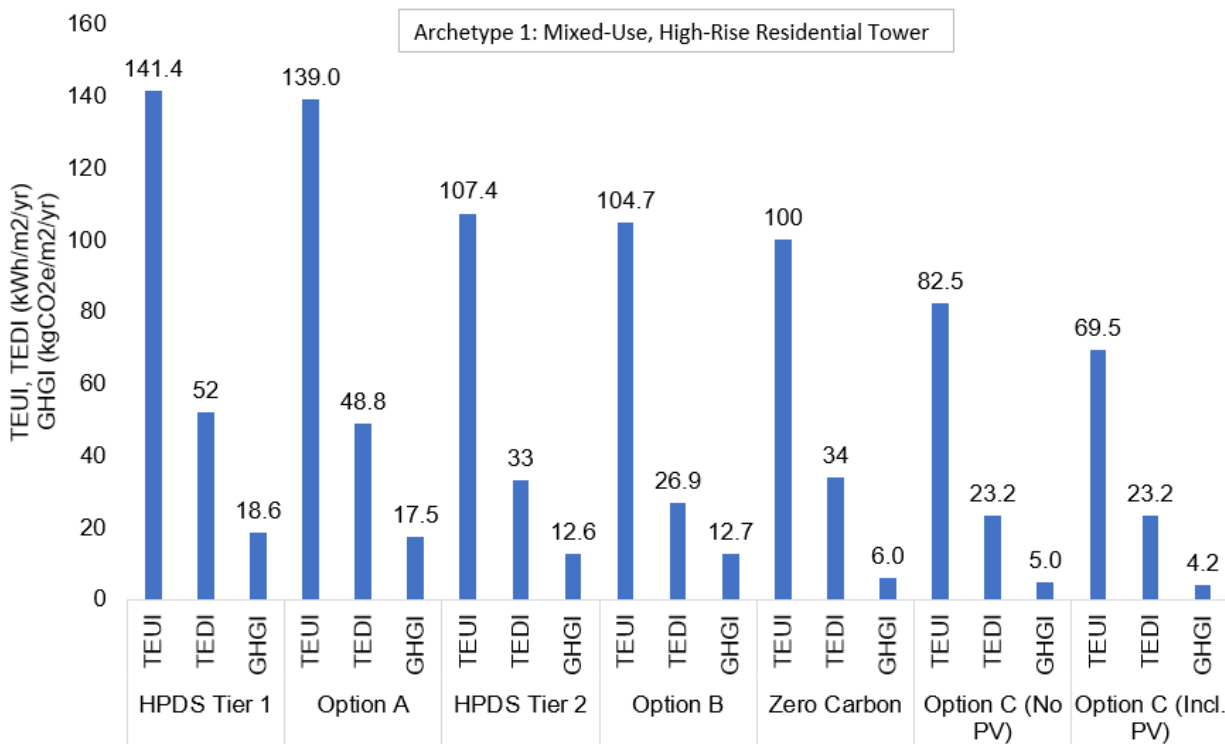

Figure 4-3: Archetype 1 Performance Metrics Achieved vs. Benchmarks

Figure 4-4 below summarizes the results of the Thermal Energy Use Intensity (TEUI), the Thermal Energy Demand Intensity (TEDI), and the Greenhouse Gas Emissions Intensity (GHGI) for Archetype 2. It can be observed that the target KPIs were met except in the case of option C, which has a higher TEDI than options A and B although its TEUI is significantly lower. The reason for this trend is the interactivity between the internal gains from lighting and plug loads with the heating energy delivered by the building HVAC system. As we start to improve the energy efficiency of the lighting, appliances, and plug loads, we see a decrease in the free heating provided by these end uses, although the heating demand remains nearly constant. The additional heat must be provided by the HVAC system, therefore increasing in the modelled TEDI value. This gives the false impression that not optimizing these loads is desirable. In actuality, these ECMs will improve the overall energy performance, including reducing the load on the cooling system. The metrics should be considered holistically to avoid drawing incorrect conclusions when designing the actual building.



LEBRETON FLATS ZERO CARBON COMMUNITY ENERGY PLAN

Design Option Development

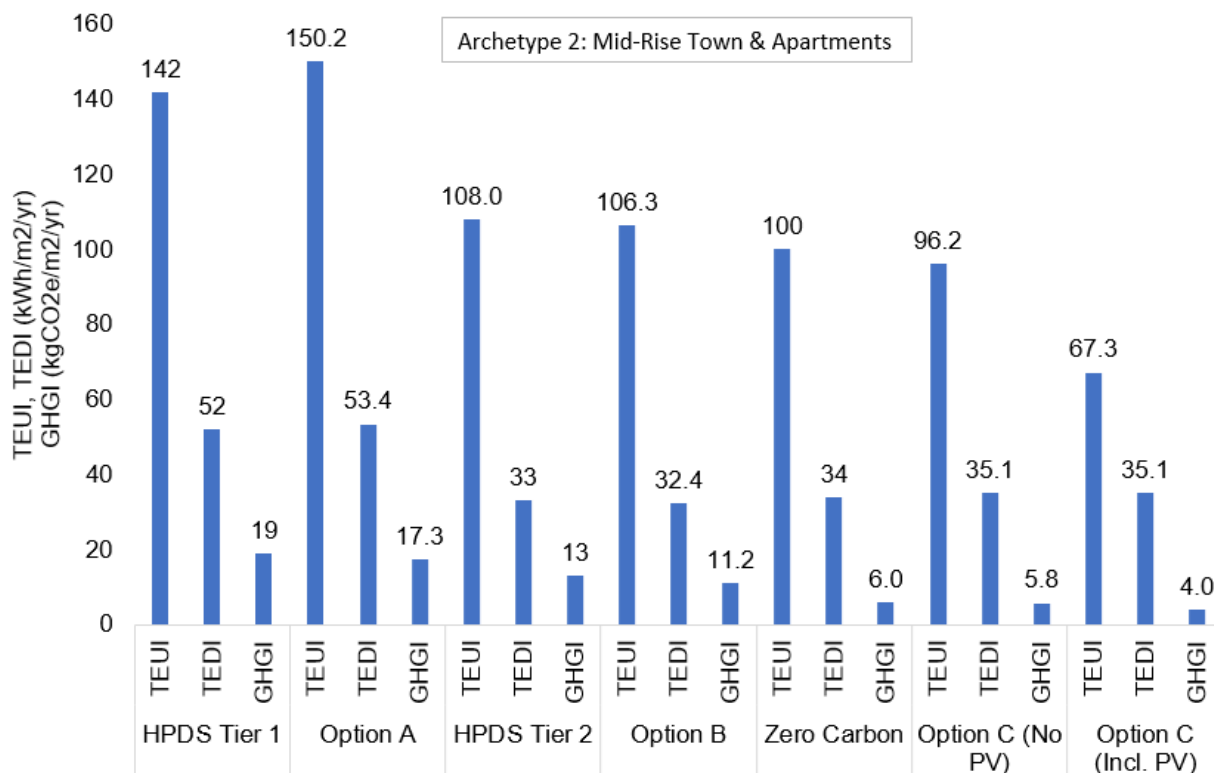

Figure 4-4: Archetype 2 Performance Metrics Achieved vs. Benchmarks

Figure 4-5 and Figure 4-6 below summarize the contribution of the major building end uses to the overall energy needs of the building. As we move from a typical baseline building designed to code requirements towards higher performing buildings, there is need to reduce the energy used by all building end uses, to achieve the required performance. A holistic approach is needed to design a high-performance building. This begins with passive envelope and occupant strategies that significantly lower the demand on the HVAC and DHW systems, followed by improving the performance of the heating and cooling systems. It is important to optimize end uses that are typically ignored when designing typical buildings or targeting low levels of energy efficiency. End uses such as plug loads, lighting, fans, and pumps become significant contributors to the overall energy consumption, once the heating and cooling needs of the building are significantly reduced.



LEBRETON FLATS ZERO CARBON COMMUNITY ENERGY PLAN

Design Option Development

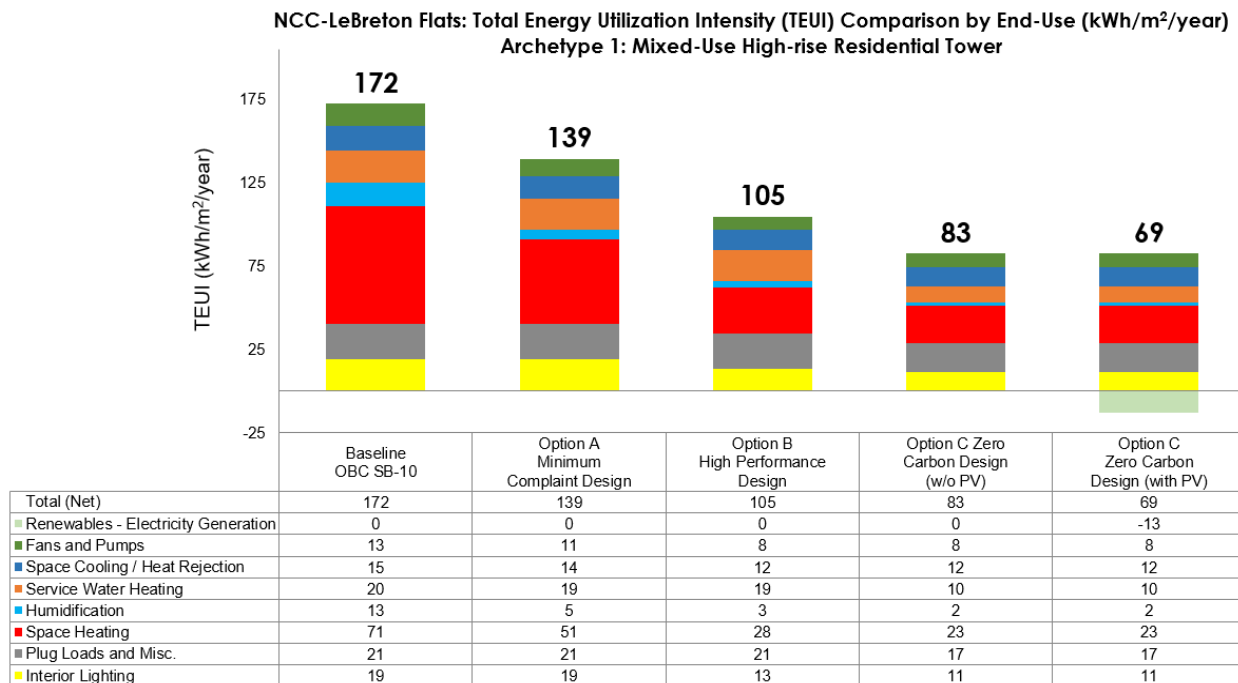

Figure 4-5: Archetype 1 End Use EUI Breakdown

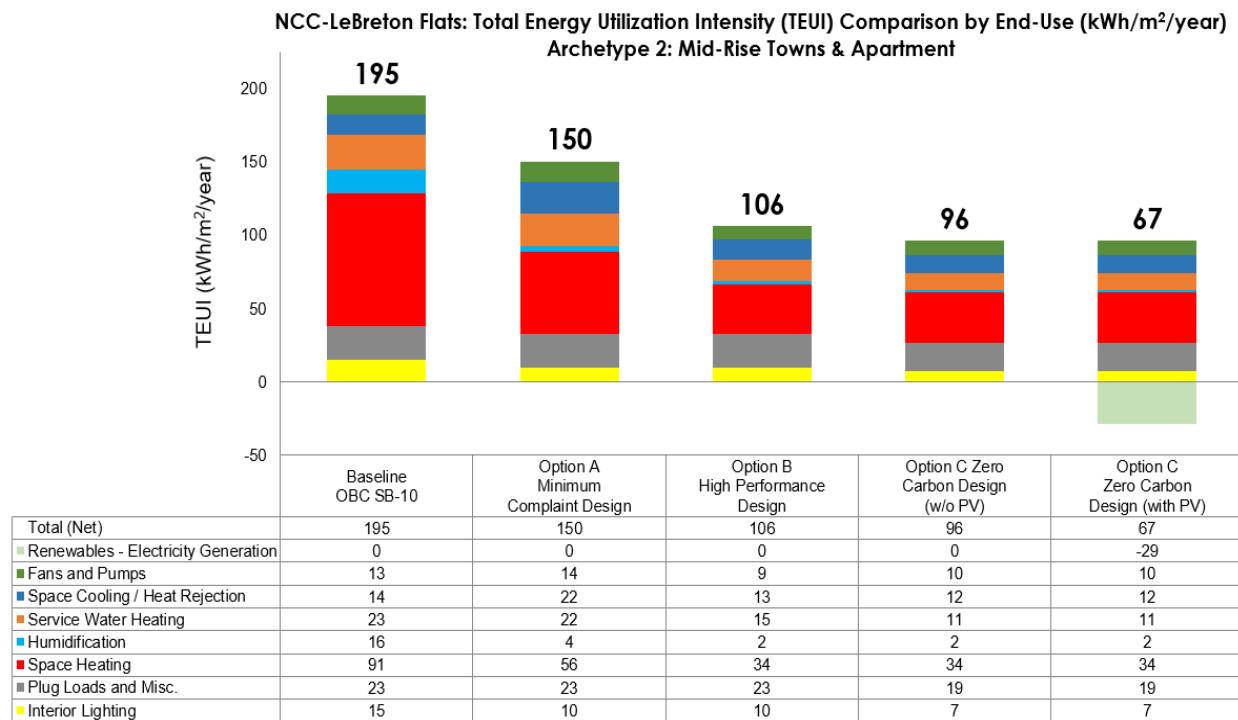

Figure 4-6: Archetype 2 End Use EUI Breakdown



4.1.10 Building Level Recommendations

The following section summarizes some of the key conclusions from the detailed analysis presented earlier in order to provide guidance to future developers building at LBF.

- **Integrated Design Process:** Designing high performance buildings needs a collective effort from all stakeholders that includes architects, engineers, and developers. The most crucial impact is often always created at the very early stage of the project and inclusion of all stakeholders in decision making helps in identifying challenges early on and avoids fixation of the architectural design. Hence, an integrated design process is a must for design expectations to match reality.
- **Performance Based Design:** Building codes and construction practices are evolving away from prescriptive approaches to construction towards detailed modelling of how the specific building design will perform (e.g., TEUI, TEDI), combined with post construction verification of energy performance. Therefore, developers should undertake detailed modelling of the effects of different design decisions on energy consumption. Developers should also account for the fact that standards may improve between the design and construction phase, and that actual construction may fall short of planned performance, so a buffer should be included so that the final constructed building does not fall short of requirements. Ensuring that buildings are actually constructed as designed is essential to high performance buildings and will increasingly become standard for all new construction going forward.
- **Fenestration-Door-Window-Ratio:** Numerous studies have attempted to find the optimal FDWR for energy performance. How the FDWR affects the performance depends on many factors such as the climate zone, window orientation, building orientation, and shading. Windows on a residential unit provide the occupants with a connection to the outdoors. With the mounting affordability issues in dense urban centers, there is a strong need for family-friendly high-density living spaces. A residential unit with higher window to wall ratio often has a higher selling price due to its visual appeal and a sense of connection to outdoors but at a later stage the occupants may start to realize the thermal discomfort and increased utility bills. Quantifying the aesthetic importance of window size and how it affects the occupant experience in MURB units is much more difficult than quantifying the energy loss of window sizes. Therefore, finding the optimal window size for MURB units needs to consider both the energy efficiency as well as occupant experience. For a climate like Ottawa an FDWR close to around 40% generally strikes a good balance between daylight optimization and opportunities to improve the façade thermal performance. It is recommended for a project team to carry out detailed daylight optimization study and analyze impacts of increasing FDWR beyond code proposed value on energy consumption. This study needs to take place early in the design development phase to ensure quantification of impacts of varying FDWR and glazing performance.
- **Thermal Bridging:** Building envelope, which includes walls, windows, and roof, is the most significant source of heat loss through the buildings. Simply installing high performance glazing or adding extra layer of insulation to the wall assemblies doesn't solve the problem of reducing heat loss through the envelope. Thermal bridging at interface details, such as slabs, parapets and



Design Option Development

glazing transitions, can be sources of significant heat flow through the building envelope. The architectural design needs to properly detail transitions between systems to ensure thermal breaks have been incorporated for mitigating thermal bridging. All design effort can be nullified if quality checks are not in place during the construction phase to verify assembly construction as intended. Hence, mitigating the impact of thermal bridging in the design of the envelope can greatly impact energy and cost savings of the building. For MURBs, exterior balconies are often a major source of thermal bridging that significantly reduces the effective R-value of the wall assembly. However, there are readily available solutions and construction practices that can mitigate this if implemented during construction.

- **Airtightness:** Building airtightness is another important aspect of high-performance buildings. Air is a transport mechanism for water, vapour, heat energy, and airborne contaminants. As a result, uncontrolled air leakage can lead to moisture issues from condensation and bulk water ingress, excessive heat loss that leads to discomfort and energy waste, as well as poor indoor air quality that affects occupant health and comfort. The architectural design needs to ensure continuity of air barrier systems to minimize air leakage. Also, mandatory airtightness testing requirements at various stages of constructions needs to be in place to seal major leaks through envelope and confirm the airtightness levels with the design goals.
- **Energy Recovery:** An airtight building relies on its mechanical system to deliver fresh air across conditioned spaces. In a climate like Ottawa, conditioning outside air to the desired room temperature requires significant effort from the mechanical system. Employing energy recovery ventilators can significantly help to reduce sensible as well as the latent load on the HVAC system, thus helping to reduce the size of the central system. It is recommended for a project team to maximize the benefits of energy recovery as they are a cost-effective solution to reduce energy use and achieve stringent TEDI metrics without compromising indoor air quality.
- **Prefabricated Components:** With the requirement to make buildings airtight and thermally efficient, typical on-site construction process can be slow and inefficient due to a shortage of skilled trades. Prefabricated wall panels can be a good alternative to the existing process. As these panels are factory-build units produced in an indoor environment, they offer economies of scale and are quality tested to confirm with the design performance.

4.2 DISTRICT OPTIONS ANALYSIS

District Energy Systems (DES) typically provide centralized heating and cooling for all buildings planned for a site and may include electrical power generation and distribution. DES are common in campus-type developments because they provide highly reliable heating and cooling, reduce maintenance and operation costs, and can incorporate low-carbon emissions energy sources which are more difficult and expensive to apply at an individual building level. As depicted in Figure 4-7 below, DES supply can be varied, including a mix of renewable and conventional energy sources.



Design Option Development

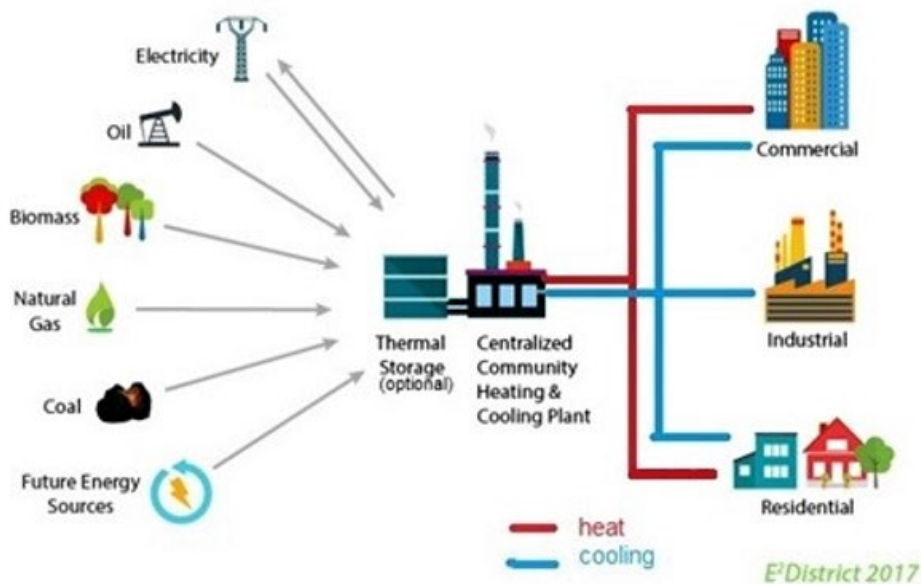

Figure 4-7: District Heating and Cooling System

DES combine heating and cooling generation in a central location with multiple buildings connected. This method is very efficient in delivering thermal energy and is often more affordable in terms of operation, maintenance, and utility delivery costs since all energy systems are in a single area. The heating and cooling equipment requires less space and frequently require less installed capacity to serve the same loads compared to installing separate energy systems for each building. However, there are additional costs for distribution infrastructure to supply heating and cooling energy to the buildings.

DES are more prevalent where one or more of the following conditions exist.

- Where an inexpensive source of heat or cooling energy is available, DES cost advantages may be significant.
- Where highly reliable thermal energy is important.
- Where long-term maintenance of central heating and cooling systems is more important than short-term costs, DES has a significant advantage. This is particularly true where the buildings served are under common management or ownership (e.g., university campuses, military bases, and health care or industrial complexes).
- Where there are complementary heating and cooling loads, DES can often provide options for heat recovery and transfer more effectively than alternatives, boosting the overall efficiency of the system.
- Where policy initiatives encourage energy efficiency or low-carbon-emission heat sources, DES can provide advantages over energy from traditional public utilities (e.g., low-carbon biomass heating fuels and geo-exchange heating are often more practical at the DES scale).



LEBRETON FLATS ZERO CARBON COMMUNITY ENERGY PLAN

Design Option Development

Barriers to DES include the following.

- DES have higher initial capital costs compared to conventional, standalone building heating and cooling systems. This can result in rates that are higher than conventional public energy utilities.
- Where there is not a clear cost advantage to DES, securing new customers can be challenging. This may be overcome by compulsory DES connection, where such local planning and permitting constraints are acceptable.
- DES energy rates may be regulated in some jurisdictions, or under particular types of DES ownership.

4.2.1 DES Loads

In order to model the DES, it was necessary to develop estimates of the total energy needs for the site using the results of the building energy modelling. The process can be summarized as follows.

- Develop estimates for the total floor area growth over time for all of LBF, based on the MCP.
- Allocate the floor area among the three space types included in the building energy models (i.e., high-rise residential, low-rise residential, and non-residential).
- Develop estimates for the energy requirements of each space type using the building energy modelling approach described in Section 4.1. Add additional process loads (e.g., refrigeration and food service) to the non-residential energy estimates.
- Multiply the floor area of each space type by the appropriate EUI from the building energy models, to determine the estimated future energy needs of the entire LBF community.

Two urban loads have been modelled to provide estimates for the maximum and minimum loads that are expected to be placed on the DES. The energy loads associated with Option A (Tier 1) represent the maximum loads. The energy loads associated with Option C (ZCB) represent the minimum loads.



LEBRETON FLATS ZERO CARBON COMMUNITY ENERGY PLAN

Design Option Development

As noted in Section 3.1, LBF will be developed over an approximately 30-year period as shown in Figure 3-2. Using this phasing plan, and in consultation with NCC, the floor area occupied in each year of the development was estimated, as shown in Figure 4-8 below.

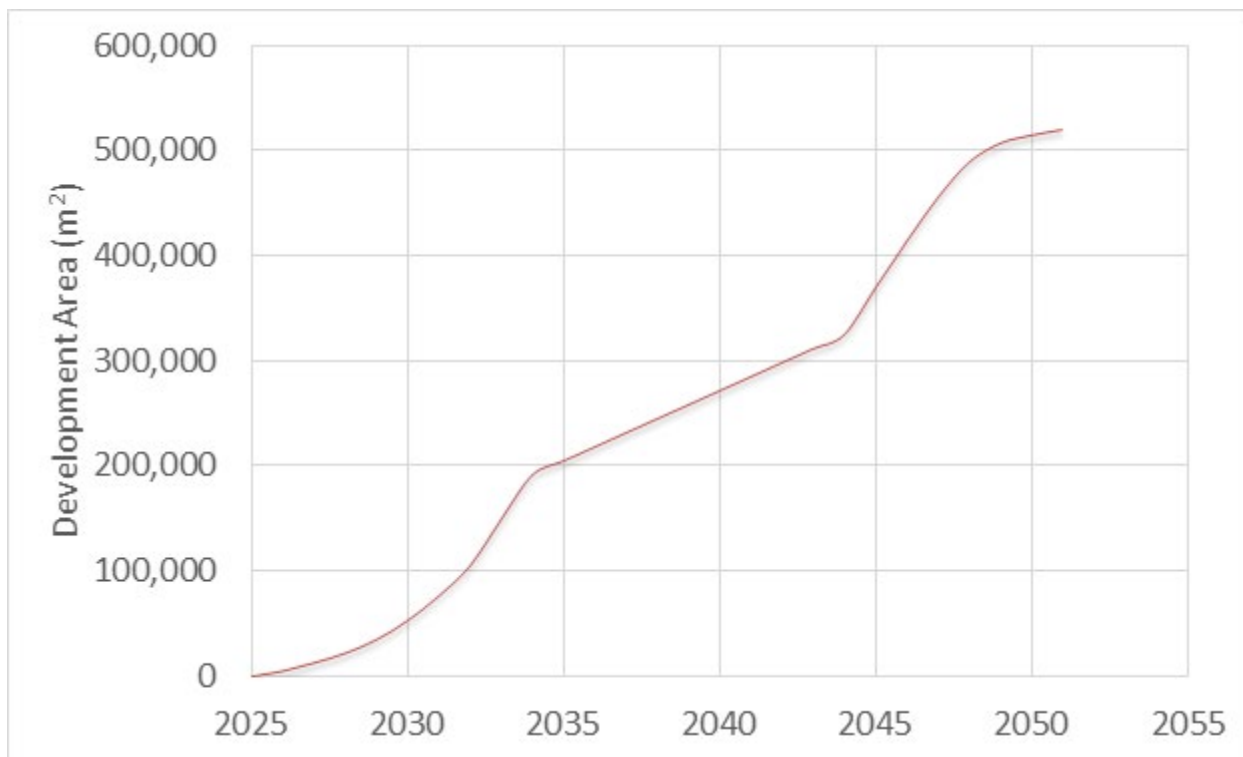

Figure 4-8: LeBreton Flats Floor Area Development



LEBRETON FLATS ZERO CARBON COMMUNITY ENERGY PLAN

Design Option Development

Combining the floor area estimates with the building archetype energy use estimates results in the estimates for space heating and space cooling demand as shown in Figure 4-9 below. The complete annual peak demand and energy estimates for space heating, space cooling, and DHW for Option A and Option C are included in Appendix F.

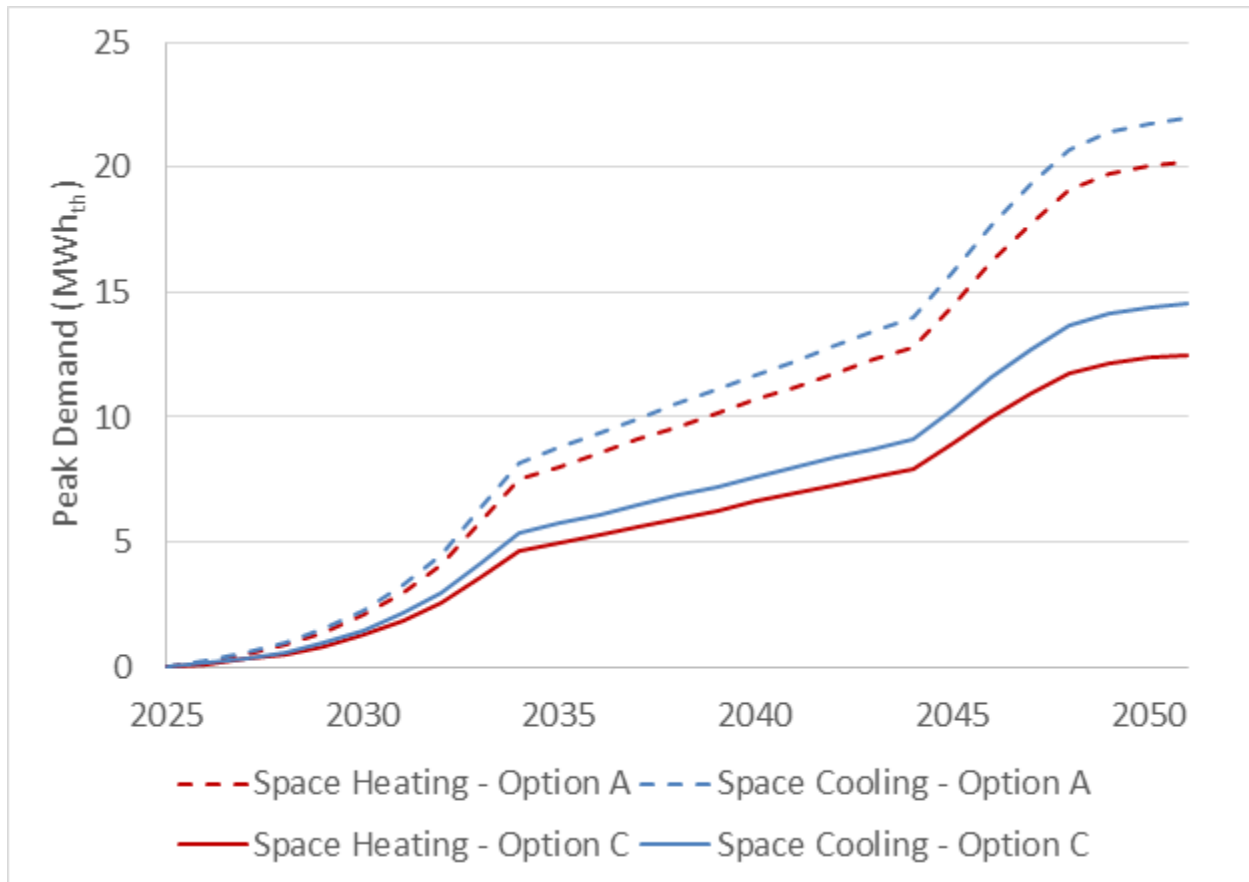

Figure 4-9: LeBreton Flats Thermal Loads



LEBRETON FLATS ZERO CARBON COMMUNITY ENERGY PLAN

Design Option Development

The two following options for the DES have been considered:

- A new zero carbon facility generating energy on-site at LB
- A connection to either of the existing systems at ZCU or ESAP

4.2.2 Option 1: LeBreton Flats Zero-Carbon DES

This option has been evaluated in significant detail. It can be considered the benchmark against which to compare other options, including the existing systems at ZCU and ESAP, as well as the standalone building systems (e.g., GSHPs).

4.2.2.1 System Configuration

Various low/no carbon energy sources have been evaluated. For this study, the use of a geo-exchange field has been selected as the primary thermal energy source. There are two basic configurations for geo-exchange systems: closed-loop and open-loop.

The closed-loop geo-exchange field concept extracts heat from the ground, via either a network (i.e., field) of horizontal or vertical boreholes drilled into the ground, or via horizontal mats buried underground. A water-based fluid (e.g., glycol) is pumped through the closed-loop piping and collects and transfers the heat from the field to the energy center it serves. A heat pump either elevates the water temperatures to levels appropriate for district or individual building heating or lowers the water temperatures for cooling. Ground water temperatures are typically between 10°C in winter and 18°C in summer. On the load side of the heat pump, supply temperatures for heat pumps vary by application. However, in heating mode, the upper practical limit of heat pumps is generally 60°C. At higher temperatures, both the heat output and coefficient of performance (COP) of the system deteriorate significantly.

Critical to the operation of a ground loop is to have enough field area and depth to ensure the ground energy is replenished on a seasonal basis. As a rule, approximately one acre (4,000 m²) of land is required per MWth of load. Because the field also receives and dissipates heat when the system is in cooling mode, part of this heat can be recovered during the heating season.

Some of the key challenges for the GSHP option include the following:

- Ground thermal conditions must be verified by drilling test wells. If the project proceeds, the test wells can typically become production wells.
- Sufficient suitable space must be available for the field.
- The seasonal heating and cooling loads served by the GSHP system must be appropriately balanced; otherwise, the field can become heat depleted or heat saturated, substantially degrading the heat pump performance.
- Because vertical boreholes may lie within the local ground water table, environmental permitting may be required. Since the regulatory environment is likely to evolve over the timeframe of the development, close coordination between the developer and the regulatory bodies will be required.



LEBRETON FLATS ZERO CARBON COMMUNITY ENERGY PLAN

Design Option Development

The open-loop geo-exchange field concept uses groundwater pumped from producing wells directly to the central energy center. Heat exchangers extract the energy, then the water is pumped back to the ground via injection wells. A heat pump raises or lowers the temperatures for use in the building or district heating/cooling system.

A key factor is to have enough aquifer flow and well spacing to ensure there will be no interaction between producing and injection wells. This prevents short-circuiting of the supply and return ground water and resultant GWHP system performance degradation.

Treatment of ground water may be required to prevent fouling of heat transfer equipment in the energy centre. Many variables affect the extraction/injection rates of wells and the interactivity between wells. A proper analysis is beyond the scope of this screening analysis.

An open-loop geo-exchange system was selected for this analysis. This was based on the smaller physical footprint required for wells, the lower anticipated capital costs, and the general understanding that this will be both feasible and permitted in the LBF area. Since the City of Ottawa sources drinking water from the Ottawa River, extracting water from wells would not impact the City's water supply, a common reason why open-loop systems may not be permitted.

Pumps located in production wells will extract water from the aquifer and deliver it to the energy centre. Heat energy will be either pulled from or rejected to the water, after which the water will be reinjected back into the ground through injection wells. Peak and backup heating energy could be provided by boilers using electricity or renewable natural gas (RNG) as the energy source.

There are several possible configurations of centralized DES. Two have been evaluated for this study.

A 4-pipe system is a conventional piping system that consists of two hot water pipes for building heating and two chilled water pipes for cooling (i.e., supply and return). Heat exchangers extract the heating or cooling energy, for direct use within the building. Central plant equipment will consist of chillers and water source heat pumps, that will interact with the water from the geo-exchange field and generate chilled and hot water. A significant benefit of this option is that no heating or cooling equipment is required at the building level. This saves significant costs to install, operate, and maintain, and frees up space in the building for other uses.



LEBRETON FLATS ZERO CARBON COMMUNITY ENERGY PLAN

Design Option Development

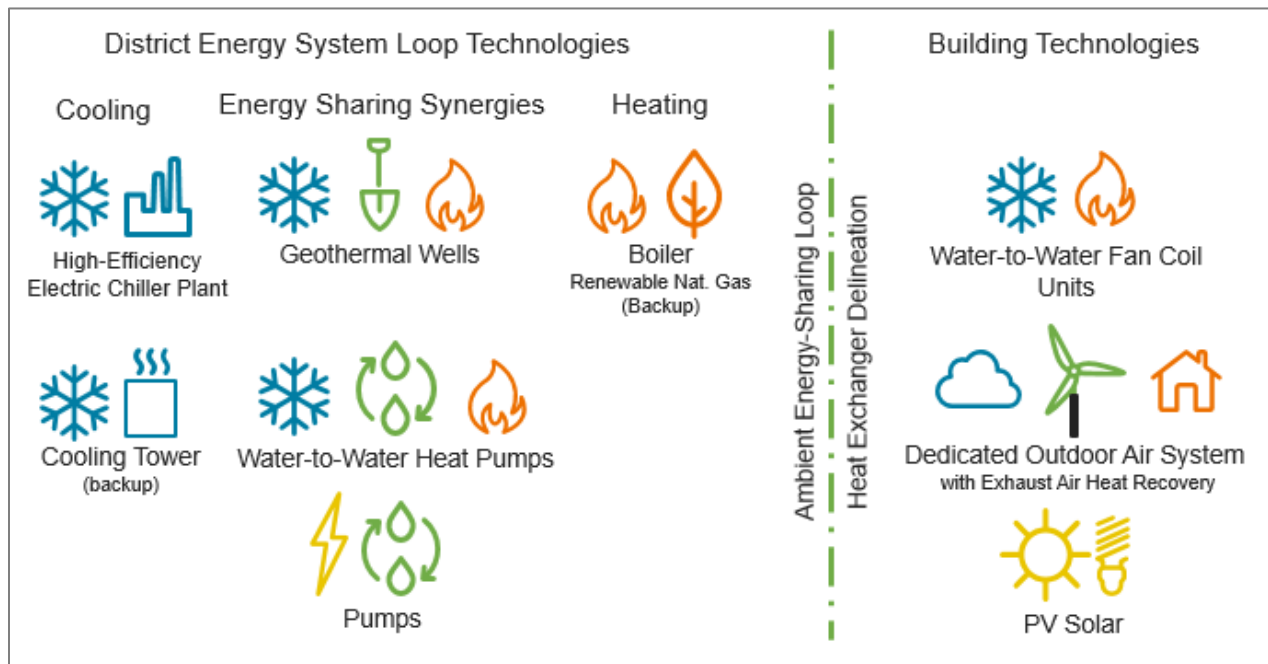

Figure 4-10: 4-Pipe District Energy System

A 2-pipe ambient temperature system consists of a piping system which circulates water at an ambient temperature to each building, where heat exchangers and water source heat pumps either reject heat into or extract heat out of the ambient loop to heat and cool the building. Central equipment maintains the loop temperature within the appropriate range, by interacting with the geo-exchange field or using backup/peaking boilers and cooling towers.

Benefits of the 2-pipe system include the following.

- Reduced capital cost of the piping distribution system, due to fewer pipes in the ground.
- Distribution piping can be uninsulated, as incidental heat loss to the ground will be low due to the ambient distribution temperatures.
- Takes advantage of simultaneous heating and cooling, either within buildings or from building-to-building, reducing the net load on the central plant.
- Lower water distribution temperatures allow for integration of many types of low-grade heat (e.g., waste heat from data centers, ice rinks, sewage heat recovery, and solar thermal). These sources can be located remotely from the central plant and connected directly to the distribution piping loop.
- Lower cooling distribution temperatures allow for central cooling without the use of a chiller. Heat can be rejected directly to the geo-exchange field or atmosphere through a cooling tower.



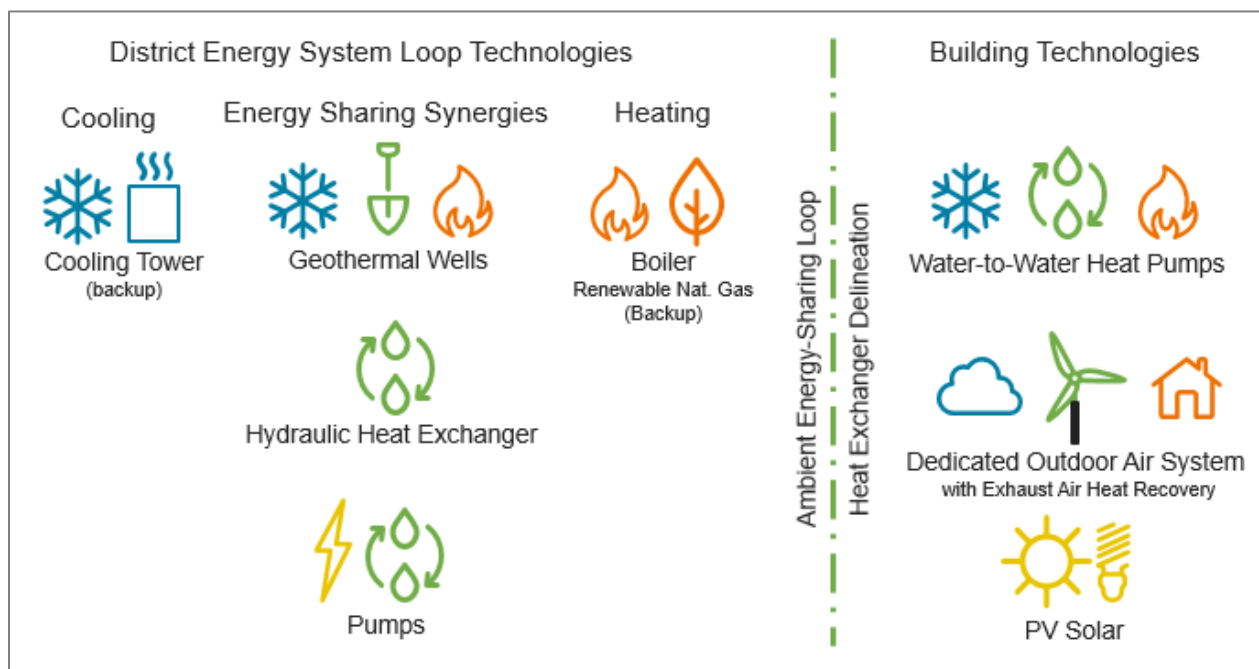

Figure 4-11: 2-Pipe Ambient Temperature District Energy System

For both the 2-pipe and 4-pipe options, the following two DES capacity options have been modelled:

- Maximum size, based on all buildings at LBF being constructed to the minimum compliant design targets (Option A)
- Minimum size, based on all buildings at LBF being constructed to the zero carbon design targets (Option C)

For a detailed explanation of how these loads were determined, refer to Section 4.2.1.

4.2.2.2 Domestic Hot Water

For both the 2-pipe and 4-pipe configurations, the temperature of the heating water supply is not optimal for serving DHW loads. Additionally, achieving the necessary sustainability performance of the DHW system is not as challenging as it is for the HVAC system, so there is less reason to shift this load from the buildings to a low carbon DES as there is for the harder to achieve space heating and space cooling loads. Therefore, DHW has been excluded from the DES model and is assumed to be served by the building systems as described in Section 4.1.6. However, since both ESAP and ZCU serve DHW loads, these loads have been estimated in case it is desirable to provide estimates to either party. This decision also does not preclude a new DES from serving the DHW loads, if this should prove to be a cost-effective option.

4.2.2.3 Environmental Considerations

The geo-exchange system configuration has been modelled as an open system, with a source well drawing water directly from the aquifer and disposing of it back into the aquifer. Other potential options include



LEBRETON FLATS ZERO CARBON COMMUNITY ENERGY PLAN

Design Option Development

disposal of the water at the surface, to the City storm sewer or to the Ottawa River. The regulatory implications of each of these options will need to be vetted with municipal and regulatory authorities. There are several factors to consider.

- The City of Ottawa draws almost all water from surface sources, making the aquifers potentially available for use with no disruption to city operations.
- The Ottawa River is currently used as a heat source/sink by many other industrial and DES, although some of these are grandfathered in and new developments may be held to higher standards.
- A hydrogeological study is required to determine the availability of the ground water, the thermal response, and the water quality. Depending on the level of contaminants found in the source water, some level of treatment may be required, prior to use by the DES and/or disposal in the Ottawa River or the reinjection well.

Should the open-loop system be determined to be unviable due to either water quality or disposal requirements, a closed-loop system may be used instead. In this case, the system configuration would be similar but deeper geo-exchange wells would be required, significantly adding to the project costs.

4.2.2.4 Ownership Structures and Implications

For the purposes of this report, we have assumed that a separate utility will be developed, likely owned by several different parties, possibly including NCC. DES ownership and operation typically fall under one of the following broad categories.

Private Ownership: This is the ownership model assumed for the purposes of this analysis, with a new utility as the owner and operator. There are numerous private firms operating in North America who specialize in DES system development, construction, ownership, and operation. Under the right conditions, many offer these services individually or in combination. Consequently, the menu of options can get quite involved, with the cost impact to the project varying considerably based on the options chosen or negotiated. In general, contracting with third-party developers to construct, own, and operate a new DES system increases costs. This is because considerable development and operational risk is transferred to the third party early in the project, before many details are known. Accordingly, this additional risk will be priced into the contract. In many instances, third-party developers can save enough through savvy planning and skilled construction to offset the inherent costs associated with this additional risk.

Cooperative or Mutual Ownership: A number of DES systems are structured as cooperatives, where customers are the ultimate owners and financial underwriters of the project. Depending on the stability and creditworthiness of the owner and customers, as well as the efficiency of the operating entity, this structure can offer the lowest financing and overhead costs of the various options. One additional benefit is that the regulatory oversight of rates is avoided since any net earnings flow to the owner/customers through either direct payments or reduced rates. Because LBF will be developed in partnership with private developers whose ownership horizons may be relatively short, structuring the DES system as a cooperative could be difficult. Examples of cooperative ownership of a DES in Ottawa include Hydro Ottawa as a partial owner of the ZCU DES. Enbridge has also expressed interest in owning and operating geo-exchange energy



LEBRETON FLATS ZERO CARBON COMMUNITY ENERGY PLAN

Design Option Development

systems as a way to diversify their revenue stream, as market share shifts from heating with natural gas to renewable forms of energy.

Government Ownership: In some instances, municipalities or other levels of local government underwrite or own the DES. This approach can provide tax-exempt financing, which lowers costs. Additionally, the expected rate of return on equity is often lower for governments.

ZCU and/or ESAP Ownership: In this scenario, either one or both of the nearby DESs could own and operate the DES system in LBF. This could have favorable economics to the case modeled, as the existing infrastructure can be leveraged to serve LBF. This could take the form of either entity supplying heating and cooling energy from their existing central plants, by extending their distribution piping into the LBF area, or by constructing new generation capacity and interconnecting into their existing distribution systems. Both ESAP and ZCU have expressed interest in developing a geo-exchange asset in the LBF area, which could be used to diversify and/or decarbonize their existing thermal generation systems.

DESs require a significant upfront investment of capital, with a potentially risky revenue stream dependent on the energy needs of the site. This is exacerbated at LBF since the development will be phased over approximately 30 years and could potentially include multiple developers with different standards of construction affecting energy demand.

Project financing in this analysis consists of the following two sources of capital:

- Equity contributions from the owners
- Loans from institutions, such as banks or governments

Both equity and loans will have a cost. This is the required rate of return expected from the equity investment, and the interest on the loan. Different parties can have significantly different expectations for rate of return and interest, which are also affected by the risk involved. The mix of equity and loan portions in the investment therefore have a significant impact on financing costs. In general, the riskier a project, the higher the equity portion and the lower the loan portion.

Grants were not considered as a financing option in this analysis. Their availability is often cyclical depending on the priorities of governments and other institutions at the time. They are often provided in the form of rebates after successful completion of a project, requiring that an alternative source of financing be in place prior to receipt of the grant. However, it is highly recommended that grants be pursued as a source of funding.

For virtually all DES ownership structures, lenders require that the fixed costs of the DES be underwritten by one or more creditworthy entities. This usually takes the form of long-term contracts with the DES customers, with owner's equity making up the remainder of any unsubscribed fixed costs. This usually means that long-term energy supply contracts consist of the following two parts.

- **A monthly fixed charge** component, based on the connected heating and cooling load of the customer. This is usually determined based on the debt service requirements of the capital investment in the system, plus fixed operating costs. Unlike typical public utility rate structures, this fixed charge typically comprises the majority of the annual bill for energy.



LEBRETON FLATS ZERO CARBON COMMUNITY ENERGY PLAN

Design Option Development

- **A variable monthly charge** for energy delivered is the second component of the typical rate. Variable charges are covered under this component of the energy rates, based on metered energy delivery.

4.2.3 Option 2: Existing DES Plants

The intent of this option was to further evaluate the possibility of connecting to the nearby DESs of ESAP and ZCU, which had been identified as viable options for future low carbon thermal energy supply to the LBF development. A consultation was held between Stantec, NCC, and representatives from ESAP on July 23, 2021, and another consultation between Stantec, NCC, and representatives from ZCU was held on July 26, 2021. Representatives from both organizations indicated that connecting LBF to their existing DES would be a possibility and did not foresee any insurmountable technical barriers. A summary of the discussions is described in the paragraphs below.

ZCU is confident that the Kruger plant will be a long-term option for waste heat supply. They cited the recent renewal of Kruger's lease, grandfathered environmental permits that are very favourable for an industrial facility, and the regional nature of the tissue business (i.e., plants tend to locate close to their markets, since long-distance shipping is not cost-effective). ZCU is also confident that they could find alternative sources of low carbon heat in the event that the Kruger plant was no longer an option.

The floor area of the LBF development is approximately 140% of the floor area of the Zibi development. ZCU is confident that there is additional waste heat supply available from the Kruger Plant, but likely not enough to meet the entire additional load of LBF. Similarly, the cooling plant could be expanded but not by the full amount required. Additional energy sources would be required, such as geo-exchange and sewer heat recovery. ZCU indicated that they would be interested in exploring the development of a geo-exchange system at LBF integrated with the ZCU DES.

The floor area of the LBF development is approximately 33% of the floor area currently served by ESAP, and ESAP is confident that LBF can be integrated into the existing network. They cited the proximity of the Cliff Heating and Cooling Plant infrastructure, a distribution trunk line passing near LBF, and the load balancing opportunities presented by the mainly residential LBF development, compared to ESAP's primarily office loads. ESAP is already investigating the potential to integrate geothermal energy into their generation mix, with several borefield test wells at LBF completed in 2021.

Both parties indicated that in order to make the business case for DES connection viable, they would need a reasonable certainty on the future thermal energy demand, either as a result of a mandatory connection requirement, or some other mechanism that incentivizes connection. The phasing of the LBF development also adds to the risk because of the need to deploy infrastructure prior to the demand being in place.

Both parties noted that an optimized installation of main buried district lines to serve regions of the development would significantly benefit all DES options under consideration.



4.3 BASELINE GROUND SOURCE HEAT PUMP OPTION

To provide a fair baseline for comparison with the net-zero carbon district energy options, we have also modelled building-level, closed-loop GHSPs as the plant-side HVAC system, as described in Section 4.1.5. This system has similar components to the DES, but has the GSHPs, pumps, heat exchangers, and other required equipment located within the buildings; each building having its own closed-loop geo-exchange system.

4.4 DES SUMMARY

The following section summarizes the results of the DES-level energy and carbon analysis for the 2-pipe and 4-pipe DES. Only the elements that form part of the DES are included here, which represents the entirety of the 4-pipe system but does not include the GSHPs in the 2-pipe system which are considered to be building elements.

Figure 4-12 below summarizes the energy consumption of the DES options, which is entirely electricity.

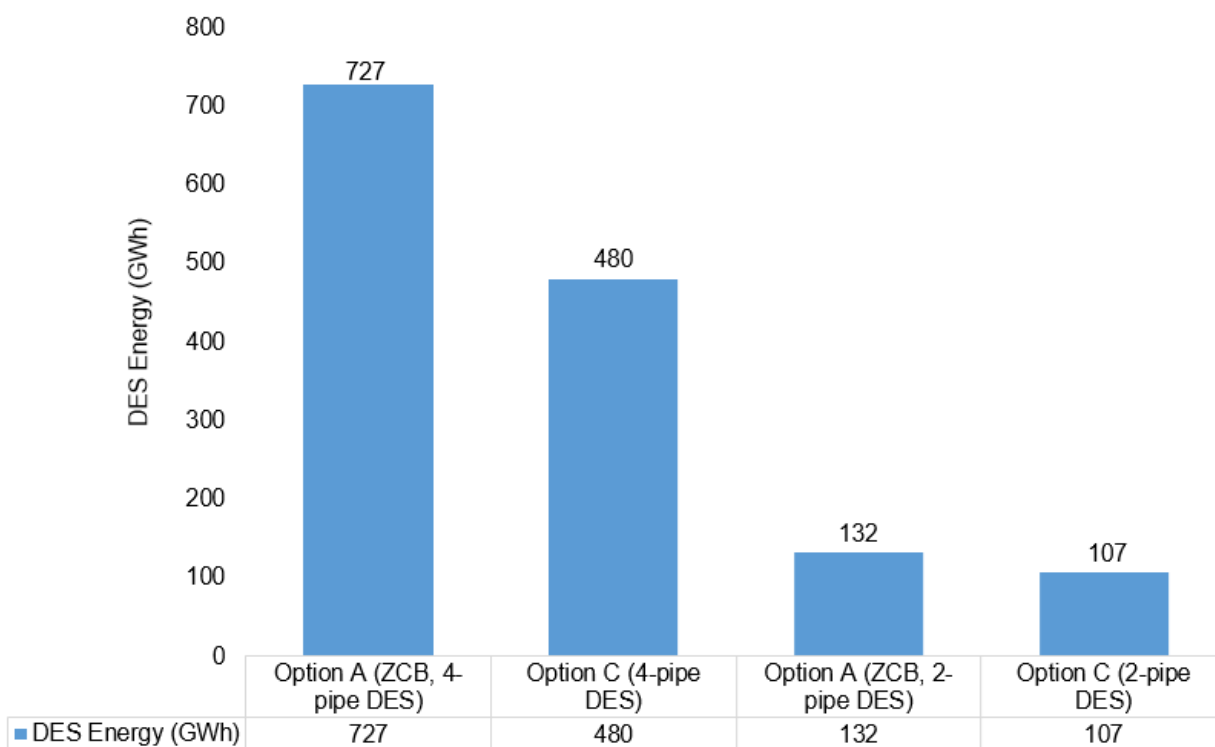

Figure 4-12: DES Space Heating and Space Cooling Energy

It can be observed that the electricity consumption of the 4-pipe system is significantly lower for Option C compared to Option A, reflecting the significantly lower thermal energy loads served by the heat pumps. The difference between Option C and Option A for the 2-pipe is lower as the heat pumps are part of the building load and reflects only the lower pumping energy for the geo-exchange loop.



Figure 4-13 below summarizes the GHG emissions associated with the electricity consumption, sourced from the Ontario grid.

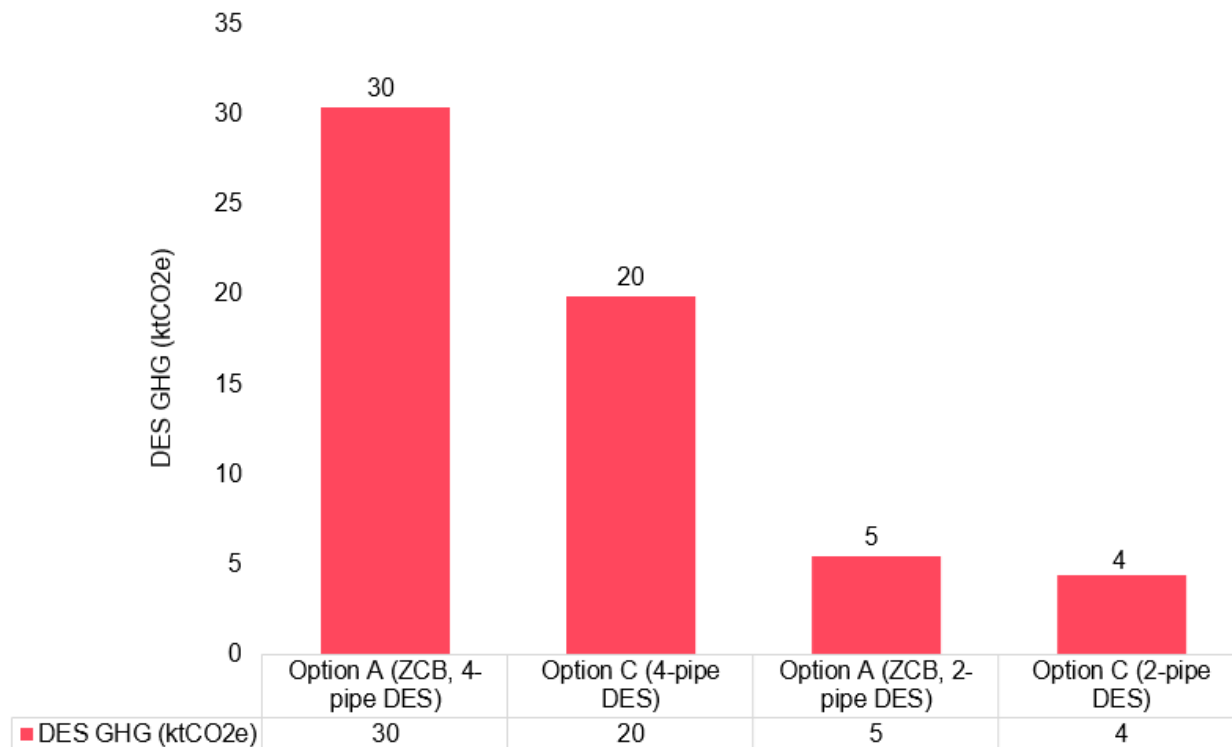

Figure 4-13: DES Space Heating and Space Cooling GHG Emissions

The trends are the same as those observed for the electricity loads, as the same emissions factors apply in all cases.

4.5 COMPARISON OF HVAC OPTIONS

The following section includes a qualitative assessment of the attributes of the three HVAC options considered (Building GSHP, 2-pipe DES, 4-pipe DES) to complement the quantitative analysis provided previously.

- Recouping capital investment:** Investments in the building infrastructure have to be financed upfront by the building developer and recouped through higher sales prices of the buildings or units and is therefore at risk of the market conditions at the time of sale. Conversely, the investment by the DES developer can be amortized over the life of the building through the rates charged for thermal energy, providing a long term, guaranteed revenue stream for the DES developer with an attractive return of investment.
- Ease of implementation:** Designing and implementing the HVAC system will be the most complicated part of the development at LBF. From the perspective of the building developer, the 4-



LEBRETON FLATS ZERO CARBON COMMUNITY ENERGY PLAN

Design Option Development

pipe DES option will be as easy or easier to develop than a typical HVAC system (e.g., boilers and chillers) as a DES connection will only require an energy transfer station in the building. The 2-pipe option will be the next most difficult, requiring the installation of heat pumps in the building, but will not require the design and installation of the geo-exchange system. The building GSHP option will be the most complicated requiring all components to be designed and installed by the building developer.

- **Resiliency:** Having all of the infrastructure located centrally improves resiliency as it is easier to implement redundant systems at scale, and easier to have a dedicated, continuously available staff located onsite. For this reason, the 4-pipe DES would have the greatest resiliency, with the building GSHP and 2-pipe options essentially having the same resiliency as the distributed GSHP infrastructure would be the most subject to failure.
- **Flexibility:** A centralized system offers improved flexibility over a distributed system in the following ways:
 - A greater potential to incorporate different kinds of energy sources due to the larger scale being able to accommodate more types of generation such as waste heat recovery. In addition, energy sources can be located further from buildings since they only need to supply their energy to the distribution loop and not directly to the building.
 - The ability to share assets such as thermal storage among multiple buildings.
 - A greater potential to be upgraded with additional assets in the future.
 - Frees up floor space within the building that would have been required for heating and cooling infrastructure and allows it to be used for other purposes such as rentable floor space, additional residential units, or building amenities.
 - Future proofing land development beyond the typical infrastructure lifecycle. Centralized systems will be easier to access and maintain than distributed building systems.
 - Allow for better coordination of infrastructure planning such as roadways, sewers, water, electricity, and natural gas infrastructure by combining planning and coordination of this infrastructure with the DES infrastructure planning process.

The 4-pipe option can achieve these benefits more easily than the 2-pipe option due to the generation assets being centralized rather than distributed among the buildings.

These attributes are summarized in Table 4-4 below.

Table 4-4: Summary of HVAC Options

Attribute	Building GSHP	2-pipe DES	4-pipe DES
Ease of Recouping Capital Investment	Lowest	Medium	Highest
Ease of Implementation (Building Developer)	Lowest	Medium	Highest
Resiliency	Medium	Medium	Highest
Flexibility	Lowest	Medium	Highest



4.6 ADDITIONAL ENERGY ELEMENTS

4.6.1 On-site Electricity Generation and Storage

While there are a variety of options for generating renewable electricity on-site, including wind and building integrated photovoltaic (BIPV), only the potential for solar PV has been evaluated as it is the most common approach taken in dense, urban developments. This doesn't preclude other options being implemented by future developers, but only solar PV will be examined further in this study.

As described in Section 4.1.8, it has been assumed that the best-case scenario for on-site solar PV generation exists when approximately 60% of the roof area of the entire LBF development can be used for solar PV arrays. This results in a PV array area of approximately 30,000 m² by 2051, once the entire site has been developed. Assuming typical performance, this system will generate approximately 8,400 MWh per year with a peak capacity of 6.7 MW. Given the limited availability of land at LBF, it has been assumed that no significant quantity of ground-mounted solar PV can be installed. This means that on-site solar PV generation can provide at most between 12% to 20% of the electricity needs of the site. The range is due to the differences in energy efficiency (i.e., between Option A and Option C) and HVAC equipment (i.e., building GSHP, 2-pipe DES, 4-pipe DES) considered for the ZCB electricity needs. It is possible that no solar PV will be installed on-site if the business case is not compelling, or the building roof area is allocated to other needs (e.g., mechanical equipment or green space).

The regulatory environment regarding generating and exporting on-site solar PV is complex, and there is significant uncertainty about what the future regulatory environment may be. Therefore, on-site solar generation has been assumed to be used behind-the-meter (BTM). This is the simplest strategy, as it doesn't require a grid connection or a feed-in-tariff (FIT) or net-metering arrangement. The value of BTM electricity generation is equal to the cost of the avoided purchased grid electricity, the same as the energy efficiency measures. The analysis of the business case for FIT or net-metering solar projects cannot be undertaken at this stage. This should be left up to the individual developers to decide at the appropriate time.

Because the inclusion of storage in a renewable generation system is an economic decision dependent on the rate structure of both bought and sold electricity, which creates the potential for price arbitrage, the potential for on-site electricity storage has not been evaluated. A developer may choose to include storage as part of their generation system, if it improves the business case for generation only or has significant non-financial benefits (e.g., improved reliability).

4.6.2 Off-site Electricity Generation and Storage

Since on-site generation has been demonstrated to be unable to meet all of the electricity needs of the site, the potential for off-site electricity generation on NCC land outside of LBF has also been evaluated. Stantec and NCC consulted with a local non-profit developer, the Ottawa Renewable Energy Co-op (OREC), to develop estimates of the amount of generation capacity that would be required for different development scenarios. OREC evaluated the potential for grid-scale wind and solar PV generation options.



LEBRETON FLATS ZERO CARBON COMMUNITY ENERGY PLAN

Design Option Development

To completely offset the annual electricity consumption at LBF, between 32,700 MWh and 72,100 MWh per year of electricity would be required by 2051, once the entire site has been developed. The range is due to the differences in energy efficiency (i.e., Option A, Option C) and HVAC equipment (i.e., building GSHP, 2-pipe DES, and 4-pipe DES) considered for the ZCB electricity needs, as well as the amount of on-site electricity that can be generated (see Section 4.6.1). The amount of generation capacity has been estimated based on offsetting the total annual energy consumption on an annual basis (i.e., annual solar generation is the same as annual energy consumption). This is not the same as sizing the solar system to entirely meet the needs of LBF and therefore grid electricity would still be required.

OREC estimates that between 23 MW and 50 MW of single axis tracking solar PV or between 16 MW and 35 MW of wind turbines would be required to meet the energy needs noted previously. The area required by the solar PV systems would be between approximately 0.93 km² (230 acres) and 3.88 km² (960 acres) of land area for the 23 MW and 50 MW installations, respectively. The area required by the wind turbines would be between approximately 2.02 km² (500 acres) and 8.50 km² (2,100 acres) of land area for the 16 MW and 35 MW installations, respectively.

Similar to storage in an on-site renewable energy generation system, the choice of whether or not to include storage in the off-site generation system depends on its value to the developer and is beyond the scope of this study.

4.6.3 On-site Thermal Generation and Storage

Possible on-site thermal generation options, not including geo-exchange as described in Section 4.2, include solar thermal DHW heating. While this is a mature and cost-effective solution, it has not been considered for LBF. This is because there is very limited roof area available, and we have assumed that any area used for on-site generation will be used for solar PV. Solar PV is a more flexible energy source since electricity is able to serve all loads; solar thermal can only serve DHW or other thermal loads.

Thermal storage can be incorporated either within the central plant, or remotely connected to the DES. The following benefits can be leveraged by using thermal storage.

Peak shaving. The proposed thermal systems use chillers and heat pumps which draw electricity from the grid. The peak electrical grid load in Ontario generally occurs in the summer during the cooling season. However, it is anticipated that this will shift to the winter because of the electrification trend. Storing either hot water in winter or cold water in summer that was been generated during off-peak (i.e., lower usage) hours can have electricity pricing benefits. Some utility contracts calculate transmission and distribution rates on a ratcheting basis, based on a user's peak annual electrical load. Thermal storage can be used to reduce the peak electrical load to avoid ratcheting costs.

Delaying capital investment. Capital expenditure on the DES is phased so that additional generation is purchased and installed as the connected load of the community is built out. Thermal storage can be an alternative means of meeting increasing peak thermal loads, without having to install additional generation capacity. This strategy can delay capital infusion for new generation equipment, having a positive impact on project economics.



LEBRETON FLATS ZERO CARBON COMMUNITY ENERGY PLAN

Design Option Development

The economics of thermal storage is highly dependent on understanding the load growth curve and the utility rate structure. It is recommended to study the possibilities of incorporating thermal storage during a future project phase.

4.6.4 Process Load Waste Heat Recovery

The most likely process that would be a viable candidate for waste heat recovery at LBF is the commercial refrigeration equipment. Large grocery stores typically have a centralized compressor bank that provides refrigeration to display cases distributed throughout the store. This makes the heat easier to recover than from distributed, self-cooled display cases commonly used in small commercial stores and restaurants. Since the waste heat is available year-round, the ideal use for the waste heat is to offset a baseload need (e.g., DHW heating) rather than a seasonal need (e.g., space heating), although this depends on the availability of a suitable heat sink.

The potential available waste heat from refrigeration at LBF has been estimated at approximately 255 kW_{th} and 2,200 MWh_{th} per year, once development is completed in 2051. For comparison, the DHW loads are estimated at between 6,600–9,600 MWh_{th} per year in 2051, meaning that the waste heat could potentially supply between 23% and 34% of the required energy load. While this percentage is not inconsequential, it does not make this waste heat supply a viable alternative to the DHW heating systems. However, it is a possible way to offset the DHW loads if it can be supplied at a lower cost than the baseline DHW heating system.

Consequently, a detailed analysis of the technical and economic potential of process waste heat should be left to the development stage of the project.

4.6.5 Sewer Waste Heat Recovery

The City of Ottawa is currently undertaking an analysis of the potential for waste heat recovery from the City's sewer network, including the Cave Creek Collector and West Nepean Collector near LBF. The City shared their preliminary findings with NCC in the form of two documents, "Wastewater Energy Transfer: City of Ottawa Scoping Study – Findings (November 4, 2021)" and "Archetype Report #4 – LeBreton Flats: Heat Supply for a District Energy System (Appendix L)". Collectively these documents are referred to as the "study" in this report, and this information has been incorporated into this section, along with relevant implications for the LBF development. The following summarizes a few key points within the study's findings considered most relevant to LBF:

- The combined average flow rates of the Cave Creek and West Nepean Collectors are approximately 848 L/s, based on modelled flow estimates developed by the City of Ottawa. The combined minimum flow rates are 443 L/s. The West Nepean Collector accounts for over 80% of the combined flow.
- The maximum winter temperature of the sewer flow was estimated to be 16.9°C based on temperature measurements collected from Kanata West. The minimum temperature was estimated to be 8.6°C.
- The available thermal power is estimated to be between approximately 6.8 MW and 22.5 MW, with the available thermal energy estimated at 42,500 MWh per year, based on an average of 17.0 MW



LEBRETON FLATS ZERO CARBON COMMUNITY ENERGY PLAN

Design Option Development

being available for 2,500 hours per year. Although only heating potential was evaluated, the study notes that the available cooling thermal energy is expected to be comparable to the heating energy.

- The study recommends that the sewer waste heat be recovered by employing a “wet well” configuration²⁷, whereby sewage is transferred from the sewer line to a wet well where the heat is recovered using heat exchangers and heat pumps, rather than recovering the heat from inside the sewer pipe using heat exchangers. This configuration maximizes the heat recovery potential but at the expense of a more complicated, larger, and costlier system. The proposed system is similar to the one described in Figure 3-9.
- The study notes that a Wastewater Energy Transfer (WET) system could have comparable energy and economic performance to a GSHP system, and could be coupled with GSHPs other energy sources, especially within the context of a DES.
- The proposed wet well configuration is estimated to cost between approximately \$1,800/kW and \$6,400/kW depending on the capacity of the system, with unit costs falling as the capacity increases. The study notes that these costs are very approximate at this stage, and only provided for guidance. These estimates potentially make the WET system cost competitive with GSHPs.
- The study identified the Interceptor Outfall Sewer located near the planned Library Parcel as a prime location for heat recovery as it is a point where the West Nepean Collector and Cave Creek Collector intersect, and the study also notes that wastewater outflow from the future LBF development could be integrated into the system.
- The study notes that more detailed hourly analysis of both the loads and available thermal energy would be required to better understand the WET system feasibility, which would include the collection of more accurate temperature and flow data from Cave Creek Collector, West Nepean Collector, Preston Street Combined Collector, and the Interceptor Outfall Sewer.

Considering the above findings of the study, and the analysis completed for LBF, the following conclusions and recommendations are made with respect to wastewater energy recovery at LBF:

- The available thermal energy that could be recovered on an annual basis is estimated to be larger than the annual thermal loads required by the LBF development. However, due to the coincidence of recovered thermal energy and the thermal loads, the evaluated WET system could not provide 100% of the required thermal needs, and other sources of energy or thermal storage would be required.
- The scale and configuration of the proposed WET system makes it a better candidate for DES integration than serving individual buildings or parcels. Connection to a DES would allow for easier integration with the additional energy sources required, as well as benefiting from the economies of scale of larger systems.
- The incremental wastewater flow estimated from LBF is negligible compared to the existing flow in the West Nepean and Cave Creek Collectors and will not alter any of the conclusions.
- The proposed WET system configuration provides flexibility in terms of where infrastructure can be located as the use of a wet well allows for the sewer access, wet well, and heat recovery

²⁷ Technology #3 – External Hx in the Wastewater Energy Transfer: City of Ottawa Scoping Study – Findings (November 4, 2021), slide 17.



LEBRETON FLATS ZERO CARBON COMMUNITY ENERGY PLAN

Design Option Development

infrastructure to be placed in different locations. This means that while the IOS is a prime location for accessing the sewer line, the ongoing development of the Library Parcel near IOS does not preclude locating a WET system near there in future or locating a comparable system elsewhere on LBF.

- Given the large potential of wastewater heat recovery to contribute to serving LBF's energy needs, further analysis of the opportunity is warranted, beginning with the collection of better flow and temperature data from sewer collectors near LBF.

4.6.6 Food Service (Cooking) Loads

As noted in Section 3.8.6, ZCB design standards strongly encourage that all fossil fuel loads be electrified but recognizes that renewable natural gas (RNG), also known as biogas, can be used as a substitute for natural gas in food service applications such as restaurants, other commercial food service preparation, and private residences.

The amount of biogas that is anticipated to be required for food service needs is approximately 7,210 MWh_{th} (2,000 GJ) per year by the time that development is completed in 2051. For context, this is between 9 and 15% of the total estimated energy needs of the site.

4.7 ADDITIONAL SUSTAINABILITY ELEMENTS

The MCP provides a holistic view of the various aspects related to sustainability and how they are intertwined with one another. The focus this study is to explore in more detail the energy and operational carbon aspects of sustainability, through the lens of the building energy requirements. However, the design and construction of buildings impacts both positively and negatively on many other aspects of sustainability and these need to be taken into consideration. This section would briefly touch upon those.

4.7.1 EV Parking and Charging Infrastructure

Every year more Canadians move into condominiums, apartment buildings, and other MURBs. In fact, around one-third of all Canadians currently live in an apartment or condo unit. This presents unique challenges for EV owners. As more Canadians transition to electric vehicles, charging stations for multi-unit residents are becoming increasingly critical and this will be the case at LBF as it being developed over the next 30 years.

Expanding EV infrastructure in MURBs is a complex process with many stakeholders involved, ranging from property managers to condo residents, electrical contractors, and electric vehicle advisors. Coordination with agencies like Hydro Ottawa would be critical for the developers to ensure optimal charging strategy and grid ancillary services.

Developments standards like the Toronto Green Standard (TGS), do recommend providing 20% of the parking spaces with electric vehicle supply equipment (EVSE), and the City of Ottawa HPDS also provides specific guidelines on electric vehicle parking for MURBs.



4.7.2 Bike Storage and Showers

Located near the downtown core with access to existing biking infrastructure, as well as many attractions and amenities within biking distance, LBF can take this opportunity to encourage biking over transport through personal vehicles and public transit. For LBF to be a bikeable community, the design of appropriate bike storage and shower facilities for both its residents and visitors will be important. Developers can refer to HPDS for detailed requirements related to both short-term and long-term bike storage for MURBs.

4.7.3 Bird Friendly Buildings

LBF would be adding to the urban densification and increase in the number of high-rise buildings in the city. Although this strategy helps in reducing land consumption, improving organization of public transport, and increased vibrant nature of existing districts, it also leads to one of the leading causes of anthropogenic bird deaths in the city. Birds can suffer from collision with buildings that don't have visual markers to help them navigate safely.

Designing bird friendly buildings requires consideration on the choice of glazing. Selecting glass surfaces having low reflectance and visual markers with appropriate spacing can significantly help in making buildings bird friendly. The NCC has developed Bird-Safe Design Guidelines²⁸ that can be relied upon by developers.

4.7.4 Stormwater Management

Stormwater begins as rainfall and melting snow and ice. In developed areas, hard surfaces like roads, roofs, driveways, and parking lots prevent water from seeping into the ground. Instead, stormwater runoff flows to catch basins while picking up contaminants like motor oil, animal waste, and cigarette butts along the way.

Landscape design at LBF needs to consider capturing and managing rainfall to improve water quality and aquatic ecosystem health while enhancing the resilience of infrastructure to extreme rainfall events.

4.7.5 Xeriscaping

Once fully developed, LBF would have 12.5 hectares of parks and open spaces (43% of the total plan area), as well as landscaping for all of the buildings at the site. There would be a requirement of greening these spaces with vegetation and this could require a large amount of fresh water just for irrigation purposes. Xeriscaping or designing landscapes to reduce or eliminate the need for irrigation can help to save a large amount of fresh water and promote biodiversity.

Growing native vegetation in the region can lower irrigation usage by 30-50% and also reduce the annual cost of maintaining parks.

²⁸ <https://ncc-ccn.gc.ca/our-plans/the-nccs-bird-safe-design-guidelines>



4.7.6 Green Roofs

A green roof or living roof is a layer of vegetation planted over a waterproofing system that is installed on roofs or spaces above podiums. Green roofs help in mitigating the urban heat island effects, provide places of respite for the occupants, and reduce stormwater runoff. Access to green spaces is known to improve the health and wellbeing of urban dwellers. Also, installing solar photovoltaic panels along with green roofs can help to improve efficiency of the panels.

New development standards like the HPDS recommend installing green roof for at least 50% of available roof space.

4.7.7 Waste Management

MURBs generate a lot of waste daily and without proper waste management strategies the majority of the waste can end up in landfills. Landfill sites generate large quantities of methane as the organic waste decomposes and contributes to environment pollution. As landfill space near urban areas runs out, both costs and carbon emissions rise as waste is transported farther from the source. Diverting recyclable and compostable waste from the landfill is an essential part of a waste management strategy.

MURBs have the lowest participation in the city waste management programs, hence design should ensure residents have easy access to garbage, recycling, and organic waste receptacles to dispose waste. In particular, MURB participation in the City of Ottawa's Green Bin composting program is very low. Providing residents with convenient ways to recycle and compost within their building will boost participation in waste diversion programs. Community level composting facilities can help to divert large amounts of organic waste going to landfills and make residents aware about its benefits, as well as offsetting onsite fertilizer use.

Organic waste such as food scraps and grease could also potentially be used as a source for generating biofuels such as renewable natural gas (RNG) or biodiesel onsite, which could be used onsite in place of grid supplied energy or sold to other users.

4.7.8 Embodied Carbon

In the context of developing the buildings at LBF, embodied carbon refers to the carbon emissions associated with materials, construction, and demolition of the buildings over their entire lifecycle. It includes any carbon created during the manufacturing of building materials (material extraction, transport to manufacturer, manufacturing), the transport of those materials to the job site, and the construction practices used. It is distinct from the operational carbon that is the main focus of this study, but it should be noted that the embodied carbon is a significant component of the lifecycle carbon of a building, often exceeding the operational carbon emissions. This is even more true of a highly sustainable building as the embodied carbon of some components such as insulation and windows are likely to increase compared to a standard building, while at the same time, the operational carbon is being reduced due to energy efficiency, fuel switching, and renewable generation.

Estimating the embodied carbon associated with a building, as well as developing strategies to mitigate it, requires detailed knowledge of the materials that will be used, their manufacturing processes, and how far



Design Option Development

and by what means they are transported. Such an analysis can only be undertaken during the detailed design phase of the buildings and verified after construction is complete. While Lifecycle Analysis (LCA) of embodied carbon is becoming more common for building construction materials, there is a lack of data in the industry and research fields regarding LCA data for mechanical, electrical, and renewable systems. This makes it more difficult to quantify the environmental impact of these systems, but it is likely that this situation will have improved by the time of development at LBF. Developers can support the process by purchasing from suppliers that commit to LCAs of their products and encouraging other suppliers to follow suit.

Some common strategies to reduce the structural embodied carbon content include using timber based structural components in place of concrete, high fractions of recycled content for steel, concrete, and asphalt, and choosing locally sourced products over importing them over large distances. Leading industry standards for net zero carbon buildings such as CaGBC's ZCB include embodied carbon in the carbon inventory for the building.

4.8 URBAN LEVEL SUMMARY

This section summarizes the energy and carbon analysis for the buildings and DES combined, providing an overall view of the urban-level results. While reviewing the building and DES results in isolation provides useful insights, the results need to be combined to fully understand the urban-level implications. The following scenarios have been considered.

Code-compliant baseline buildings for comparison purposes. Their energy sources are grid electricity and natural gas. These buildings achieve net-zero carbon emissions through the use of RECs for electricity and offsets for natural gas emissions. However, they would not be compliant with CaGBC's ZCB standard, due to the combustion of fossil fuels on-site.

Buildings compliant with the City of Ottawa's HDPS Tier 1 benchmarks for TEUI, TEDI, and GHGI, as described in Section 3.5. Their energy sources are grid electricity and natural gas. These buildings achieve net-zero carbon emissions through the use of RECs for electricity and offsets for natural gas emissions. However, they would not be compliant with the ZCB standard, due to the combustion of fossil fuels on-site.

Option A and C buildings (with differing levels of energy efficiency between them), with the three following options for heating and cooling energy:

- Building-level closed-loop GSHPs
- Two-pipe ambient temperature DES
- Four-pipe DES

Their energy sources are grid electricity, electricity generated on-site, and renewable natural gas. These buildings achieve net-zero carbon emissions through the use of RECs for electricity and are considered compliant with the ZCB standard, as no fossil fuel is combusted on-site and RNG is only used for food-service loads.



LEBRETON FLATS ZERO CARBON COMMUNITY ENERGY PLAN

Design Option Development

Figure 4-14 below summarizes the total energy consumption of all of the options.

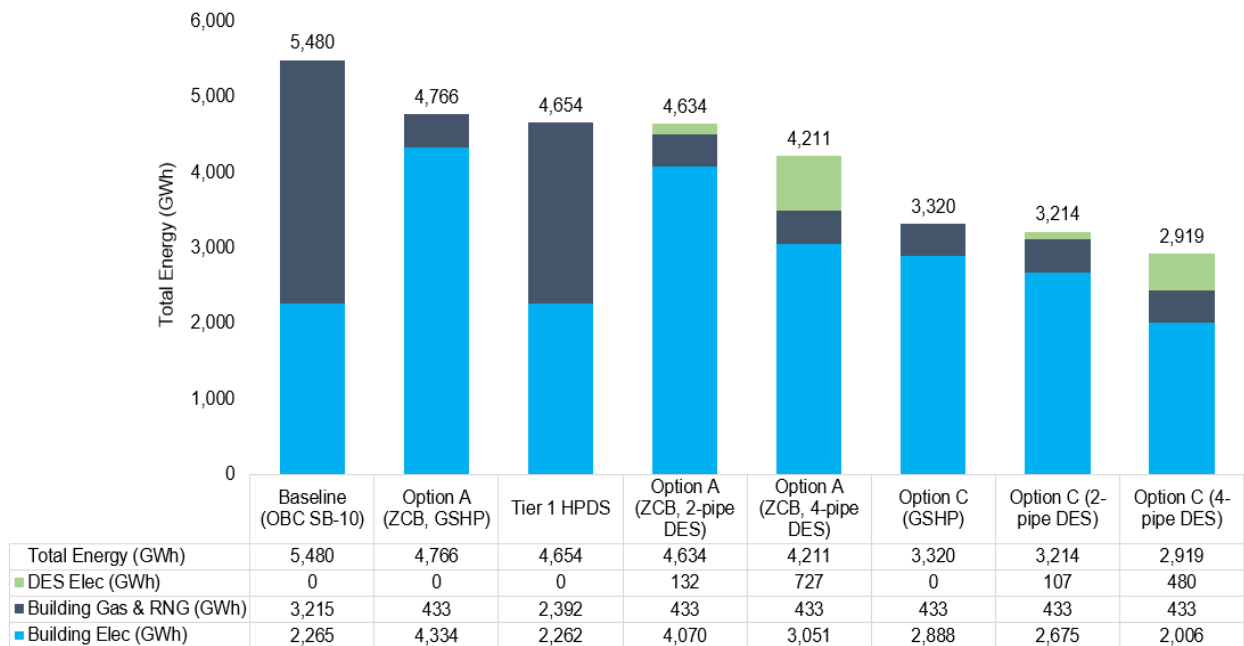

Figure 4-14: Total Urban Energy Use

It can be seen that energy efficiency has the largest impact on total energy use, with all three Option C scenarios surpassing the other scenarios. There are only modest differences in the energy requirements of the three HVAC options (i.e., GSHP, 2-pipe, and 4-pipe) at the same level of efficiency (i.e., Option A and Option C). The Option A GSHP scenario uses slightly more energy than the Tier 1 HPDS scenario. Both have the same level of efficiency, because the increased pumping energy associated with Option A GSHP offsets the improvements from electrifying the natural gas-fired space heating system for Tier 1 HPDS.



LEBRETON FLATS ZERO CARBON COMMUNITY ENERGY PLAN

Design Option Development

Figure 4-15 below summarizes the total carbon emissions associated with the options.

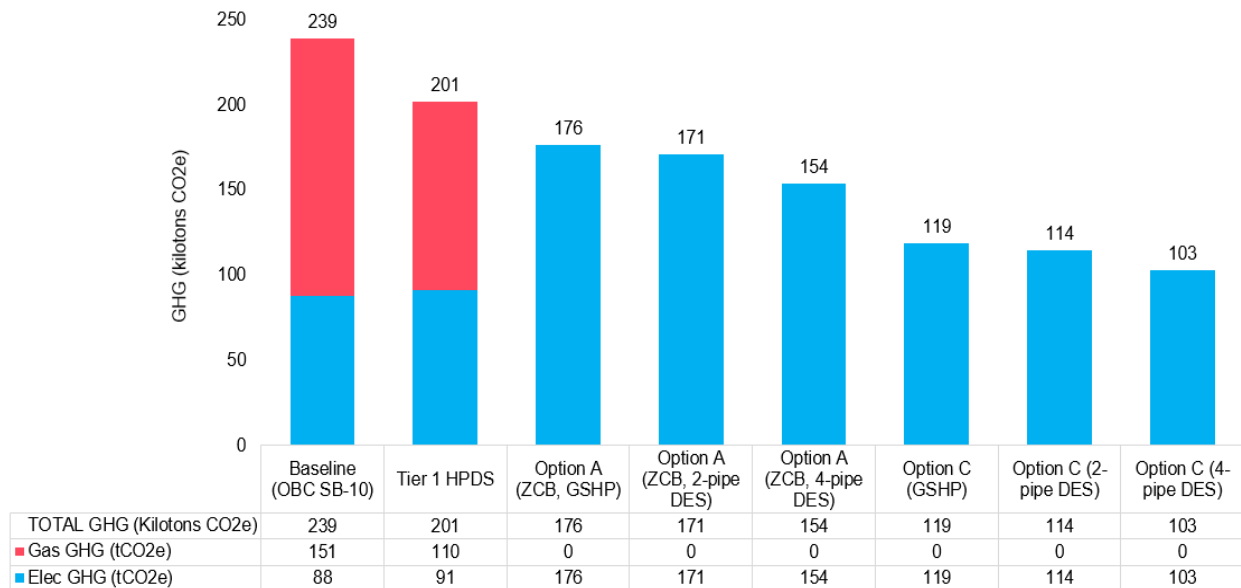

Figure 4-15: Total GHG Emissions

Trends are similar between Figure 4-12 and Figure 4-13. However, the baseline code and Tier 1 buildings in Figure 4-13 have significantly higher carbon emissions due to the use of natural gas. The other scenarios only use electricity and zero carbon RNG (i.e., biogas) as primary energy sources for the buildings and DES. The Option C scenarios reduce emissions compared to the other scenarios.



5.0 ECONOMIC ANALYSIS

5.1 INTRODUCTION

The economic analysis (i.e., business case) contained in this report uses a net present value (NPV) approach to measure the lifecycle costs of each of the two alternative DES configurations, as well as the baseline building GSHP option. All configurations were modelled under the high demand (Option A) and low demand (Option C) energy scenarios.

The results of the economic analysis are presented in two ways. Firstly, only the economics of the DES and building GSHP HVAC options are considered with the NPV and levelized cost of energy (LCOE) evaluated. This allows for a direct comparison between the alternative heating and cooling systems under consideration but doesn't take into account the impacts of energy efficiency between options A and C. Secondly, the NPV of the entire campus is evaluated, taking into account the costs and energy impacts of all building components, including aspects unrelated to the DES (e.g., lighting loads). This allows for a more holistic analysis of the entire scenario.

Finally, a sensitivity analysis was undertaken to estimate the impacts of uncertainty in estimating the various inputs to the model, and to provide confidence in the results.

5.2 KEY ASSUMPTIONS

5.2.1 Buildings

The following key assumptions were employed when undertaking the economic analysis of the building infrastructure.

- Built out annually consistent with the floor area growth assumptions presented in Figure 4-8.
- Capital costs for all measures except GSHP were derived from CaGBC's Making the Case for Building to Zero Carbon Report²⁹ published in 2019 using CaGBC's "Mid-Rise Multi-Unit Residential" archetype as a proxy for LBF's Archetype 1: Mixed-use residential tower and CaGBC's "Low-Rise Multi-Unit Residential" archetype as a proxy for LBF's Archetype 2: Mid-rise towns & apartments. GSHP costs were adapted from Stantec's analysis of implementing GSHP for other buildings in the National Capital Region. The incremental capital costs relative to a comparable code baseline building are summarized below:

Scenario	GSHP (\$/m ² / %)	Other Measures (\$/m ² / %)
Archetype 1, Option A	\$229 / 5.7%	\$0 / 0%
Archetype 2, Option A	\$229 / 6.9%	\$0 / 0%
Archetype 1, Option C	\$145 / 3.6%	\$132 / 3.3%
Archetype 2, Option C	\$145 / 4.4%	\$163 / 4.9%

²⁹ <https://www.cagbc.org/makingthecase>



LEBRETON FLATS ZERO CARBON COMMUNITY ENERGY PLAN

Economic Analysis

- Operations and maintenance (O&M) costs were assumed as follows:
 - One incremental full-time equivalent (FTE) employee at \$100,000 per year to service the building GSHP infrastructure, for every 100 occupied residential units for the GSHP scenarios.
 - One incremental FTE employee at \$100,000 per year to service the building GSHP infrastructure, for every 150 occupied residential units for the 2-pipe DES scenarios.
- Weighted average cost of capital (WACC) of 7.80%, to be consistent with the DES assumptions. In practice, there are likely to be thousands of different investors (e.g., condo owners) in the building infrastructure, with different amounts of debt and equity, as well as different borrowing costs for debt and expectations for rates of return on equity.
- Timeframe of 60 years for the building lifecycle cost analysis (LCCA) has been selected, consistent with CaGBC's guidelines for Zero Carbon Building design.
- Asset renewal cost of 1.67% per year, to account for replacement of equipment over the modelled 60-year timeframe of the building lifecycle analysis.
- Annual inflation rate of 2.0%, consistent with both historical trends³⁰ and long-term OECD forecasts for Canada³¹, to adjust pricing as appropriate.
- Discount rate consistent with the rate of inflation.

5.2.2 District Energy System

The following key assumptions were made when undertaking the economic analysis of the DES infrastructure.

- LBF is currently a partially developed site, with no existing buildings requiring energy from the proposed DES. To avoid spending too much on DES infrastructure too soon in the project, we have assumed that the DES infrastructure will be constructed in three phases.
 - Years 1–10: The initial phase will provide the central heating plant and the initial part of the distribution system needed to serve the buildings, which are anticipated to be operational within the first 10 years of site development.
 - Years 11–20: The next phase of the DES construction is implemented.
 - Year 21: The final stage is completed, with sufficient capacity to serve all buildings planned for the site.
- Capital costs were developed by Stantec's DES experts to a prefeasibility level by estimating the capital and installation costs for individual components forming the following sub-systems: wells and associated piping, distribution and metering, central plant structure, central plant equipment, trenching, bedding, and backfill, and building equipment (primarily GSHP).
- O&M costs include three (3) full-time equivalent (FTE) employees at \$100,000 per year to undertake routine maintenance and satisfy regulatory requirements. This applies to all DES scenarios.
- Debt servicing assumptions:
 - 65% debt, 35% equity

³⁰ <https://www.bankofcanada.ca/rates/related/inflation-calculator/>

³¹ [Canada Inflation Forecast 2019-2024 and up to 2060, Data and Charts - knoema.com](#)



LEBRETON FLATS ZERO CARBON COMMUNITY ENERGY PLAN

Economic Analysis

- 30-year loan term
- 5% loan interest rate
- 13% pre-tax return on equity
- Taxes are not considered in the analysis as it is too early to know at this stage of the project what tax structure may apply to the DES, as well as possible tax incentives that may apply. The choice of the above pre-tax return on equity somewhat mitigates this.
- The implication of the above assumptions results in a 7.80% weighted average cost of capital (WACC). The debt servicing assumptions were developed in consultation with stakeholders during Workshop #3.
- A timeframe of 60 years for the DES lifecycle cost analysis (LCCA) has been selected, to maintain consistency with the building LCCA timeframe.
- Since modelling depreciation uses very specific depreciation curves for each asset class, it is premature to undertake such an analysis at this stage. Instead, an asset renewal cost of 1.67% per year has been included, to account for replacement of equipment over the modelled 60-year timeframe of the DES LCCA.
- Annual inflation rate of 2.0% consistent with the buildings approach was used.
- Discount rate consistent with the WACC was used.

5.2.3 Utility Costs

This section summarizes the assumptions used in the analysis for the costs of the different energy sources available to LBF.

5.2.3.1 Grid Electricity

It has been assumed that grid electricity for LBF would be provided by Hydro Ottawa and has been priced using the appropriate rate structure for residential³² and commercial³³ customers, to estimate costs at the building level and using a large volume commercial rate³⁴ for the DES. Rate increases have been based on estimates of the Hourly Ontario Energy Price (HOEP) provided by the Independent Electricity System Operator's (IESO) long term forecast³⁵. It has been assumed that the IESO's forecast factors in the impact of the federal carbon price on the electricity price. Delivery costs have been assumed to stay constant in real terms over the course of the study (i.e., escalate at the same rate as inflation).

5.2.3.2 Grid Natural Gas

It has been assumed that Enbridge would supply any natural gas provided to LBF through Ontario's natural gas distribution system. Natural gas from fossil fuel sources has been priced using Rate 6: General Service

³² <https://hydroottawa.com/en/accounts-services/accounts/rates-conditions/residential-rates>

³³ Hydro Ottawa Commercial less than 50 kW, <https://hydroottawa.com/en/accounts-services/accounts/rates-conditions/business-rates#commercial>

³⁴ Hydro Ottawa Commercial 1.5 MW - 5.0 MW, <https://hydroottawa.com/en/accounts-services/accounts/rates-conditions/business-rates#commercial>

³⁵ <https://www.ieso.ca/en/Sector-Participants/Planning-and-Forecasting/Annual-Planning-Outlook>, Figure 36, Scenario 1



LEBRETON FLATS ZERO CARBON COMMUNITY ENERGY PLAN

Economic Analysis

for multi-unit residential buildings and small retail, and Rate 135: Seasonal Firm Service for the DES consumption³⁶. The long-term commodity price forecast factors in the wholesale market price estimate from the US Energy Information Administration (EIA)³⁷ and the Canadian federal carbon price. Delivery costs have been assumed to stay constant in real terms over the course of the study (i.e., escalate at the same rate as inflation).

5.2.3.3 Renewable Natural Gas

It has been assumed that renewable natural gas (RNG), also known as biogas, would be supplied by Enbridge through the natural gas distribution system. RNG prices have been estimated based on Enbridge commodity prices³⁸, assuming that delivery charges will be similar to Rate 6 (i.e., consistent with the natural gas supply scenario). The International Energy Agency (IEA) predicts that RNG costs will decrease slightly over the next 20 years as supply increases³⁹. To be conservative, this study has assumed that prices will be stable (i.e., escalate at the same rate as inflation). Generating RNG on-site from sources such as food waste is also a possibility, but the economics would need to be competitive with grid supplied RNG.

5.2.3.4 Water and Sewer

Charges for water and sewer are based on appropriate rates for multi-unit residential buildings (MURBs) from the City of Ottawa⁴⁰. Future rate escalations have been based on historical price increases, which have consistently averaged approximately 5% nominal per year for the past decade. The bulk of the price increase has been attributed by the City to replacing aging water and wastewater infrastructure, this trend is expected to continue long-term.

5.2.3.5 Existing DES Plants

During consultations between Stantec, NCC, and representatives from ZCU and ESAP, the possible rate structure that could apply to LBF if supplied by these plants was discussed. However, neither entity was able to provide indicative pricing, citing the following reasons:

- To properly compare to the carbon neutral systems being studied, alternative thermal generation systems would need to be added to their systems. As well as requiring further analysis to determine reasonable estimates for these costs, they would need to determine how to divide these costs between existing customers and new customers at LBF.
- They would require more details regarding the loads (i.e., peak and total energy consumption) being added to their systems. This study has produced the full set of results needed by any DES developer to undertake such modelling.

³⁶ <https://www.enbridgegas.com/-/media/Extranet-Pages/Business-and-industrial/Commercial-and-Industrial/Large-Volume-Rates-and-Services/EGD-Rates/Rate-handbook.ashx?rev=2a09811b84584638976c434e0f239651>

³⁷ <https://knoema.com/ncszerf/natural-gas-price-forecast-2021-2022-and-long-term-to-2050>

³⁸ <https://www.enbridgegas.com/sustainability/renewable-natural-gas>

³⁹ https://iea.blob.core.windows.net/assets/03aeb10c-c38c-4d10-bcec-de92e9ab815f/Outlook_for_biogas_and_biomethane.pdf

⁴⁰ <https://ottawa.ca/en/living-ottawa/water-utility-bills/rates-and-fees>



LEBRETON FLATS ZERO CARBON COMMUNITY ENERGY PLAN

Economic Analysis

As pricing is not available at this time, it is not possible to evaluate the economics of using the existing ESAP and ZCU DESs to serve LBF. However, understanding that each system would be able to leverage some of their existing infrastructure, all other things being equal, they may be able to provide more favorable pricing as compared to the new net-zero carbon DES proposed for LBF. Therefore, while not including an economic analysis of serving LBF with low carbon thermal energy from ZCU or ESAP, this study has provided a solid framework with which to compare other DES options against going forward.

5.2.3.6 Summary

A summary of the utility cost estimates employed in this study is included in Table 5-1 below. The complete set of annual utility cost estimates are included in Appendix E.

Table 5-1: Summary of Utility Costs

	2021	2025	2030	2040	2050	2075	2100
Grid Electricity							
HOEP (\$2020/MWh) ¹	\$16.86	\$23.82	\$32.27	\$38.42	N/A	N/A	N/A
Buildings (\$2020/MWh)	\$101.04	\$142.75	\$193.39	\$230.25	\$302.75	\$600.26	\$1,190.09
DES Energy (\$2020/MWh)	\$16.87	\$23.83	\$32.28	\$38.43	\$50.54	\$100.20	\$198.66
DES Demand (\$2020/kW)	\$9.67	\$9.67	\$9.67	\$9.67	\$9.67	\$9.67	\$9.67
Grid Natural Gas							
EIA (\$2020/MMBTU) ²	\$2.61	\$3.05	\$3.48	\$3.71	\$4.11	N/A	N/A
Buildings (\$2020/m ³)	\$0.31	\$0.41	\$0.53	\$0.49	\$0.46	\$0.45	\$0.50
DES (\$2020/m ³)	\$0.30	\$0.43	\$0.58	\$0.55	\$0.55	\$0.67	\$0.93
RNG (\$2020/m ³)	\$1.08	\$1.08	\$1.08	\$1.08	\$1.08	\$1.08	\$1.08
Water & Sewer ³ (\$2020/m ³)	\$4.01	\$4.51	\$5.23	\$7.03	\$9.45	\$19.79	\$41.43

1. Hourly Ontario Energy Price (HOEP) forecast is only available to 2040. Price escalations were assumed to be 2.8% per year (real) from 2041 onwards, based on the average change from 2015 to 2040.

2. EIA Henry Hub forecast is only available to 2050. Price escalations were assumed to be 1.8% per year (real) from 2051 onwards, based on the average change from 2020 to 2050.

3. Water and sewer charges were not differentiated in the forecast as they typically apply to the same volume (being based on the metered water delivery) and it is unknown what cost recovery model the City will use for water vs. wastewater infrastructure and O&M costs.

5.2.4 Carbon Costs

The future development at LBF would be directly financially impacted by carbon costs in two ways.

- The federal carbon price would raise the price of fossil fuels purchased for energy generation; mainly for natural gas that would either be combusted on-site for thermal energy or would be used to generate grid electricity purchased by the site. The carbon price would therefore be reflected in the natural gas rates or electricity rates paid by the end users at LBF.



LEBRETON FLATS ZERO CARBON COMMUNITY ENERGY PLAN

Economic Analysis

- There would be costs associated with achieving net-zero carbon emissions (i.e., paying to create the negative emissions required to offset the emissions generated by the development).

LBF would have several options for offsetting the carbon emissions associated with its consumption of grid electricity. These include purchasing renewable energy credits (RECs) equal to the amount of electricity purchased from the grid (i.e., MWh), purchasing off-site renewable electricity directly from a generator (i.e., a power purchase agreement), and purchasing non-REC carbon offsets equal to the carbon emitted from electricity generation (i.e., tons/CO_{2e}). However, as noted in Section 3.10, RECs are considered a better option than other offsets. PPAs achieve similar outcomes to RECs, but through a direct relationship between the electricity generator and consumer rather than a third party; assuming that similar care is taken to ensure additionality and persistence of emissions reductions.

Renewable natural gas is considered to be emissions-free for the purposes of this analysis, as any required offsets will have been taken care of by the supplier and included in the rate structure (see Section 5.2.3.2). Offsets are considered to be the only option available for natural gas and other fossil fuels used on-site (e.g., diesel for emergency power generation), as there are currently no generally accepted RECs frameworks for these fuels. However, there are various voluntary certificates traded in the market, and standards are evolving to recognize the need for renewable fuels for hard-to-electrify end uses.

Providing a comparison between carbon costs (e.g., RECs and PPAs) quoted in energy units (\$/MWh) and quoted in carbon emissions (\$/tCO_{2e}) can be challenging. It requires accurate emissions factors to determine the amount of carbon associated with each unit of grid electricity (tCO_{2e}/MWh), which is a complex task (see Section 3.9). The cost of RECs and PPAs becomes higher relative to other carbon offsets as grid electricity emissions factors are reduced, making them less cost competitive. Approximate estimates of the carbon cost (\$/tCO_{2e}) for renewable electricity (RECs and PPAs) have been provided in this section, to allow for comparison with other carbon cost metrics.

5.2.4.1 Federal Carbon Price

Carbon prices are a market mechanism to incentivize the reduction of GHG emissions associated with energy consumption, by increasing the costs of high-carbon energy. The only direct carbon price applicable to LBF is the federal carbon price established through the Greenhouse Gas Pollution Pricing Act (2018). At LBF, the carbon price is expected to lower GHG emissions in the following three ways.

- It will encourage energy efficiency, by increasing the price of all energy sources with a carbon content (e.g., natural gas and electricity) and providing a greater incentive to reduce those costs.
- It will encourage switching from higher carbon content energy sources (e.g., natural gas) to lower carbon content energy sources (e.g., electricity), by lowering the price differential between electricity and gas.
- It will encourage the use of on-site renewable generation, by lowering the cost differential between generating low carbon renewables and purchasing higher-carbon grid energy.

The federal carbon price is currently \$40/ton and is expected to increase each year until it reaches \$170/ton (in current dollars) by 2030. There are no firm commitments from the government regarding any price changes beyond 2030. Therefore, it has been assumed that the price will remain constant in current dollars



LEBRETON FLATS ZERO CARBON COMMUNITY ENERGY PLAN

Economic Analysis

for the remainder of the study (i.e., the price will decline in real terms). The federal carbon price has been assumed to impact the grid electricity and grid natural gas prices as noted in Section 5.2.3.

5.2.4.2 Renewable Energy Certificates

Renewable energy certificates (RECs) are generally considered the best way to achieve carbon offsets from grid electricity consumption, as they typically account for additionality and persistence more effectively than other offsets. Currently, RECs have been assumed to only apply to emissions from electricity generation but may include renewable forms of natural gas and other biofuels in the future.

RECs are purchased in addition to rather than in place of grid electricity. Therefore, the RECs costs are also incremental to the cost of purchasing grid electricity, as shown below:

$$\text{Cost of purchasing net-zero carbon electricity} = \text{Grid electricity cost} + \text{RECs cost}$$

RECs are currently priced at an average of \$25/MWh, according to a 2019 CaGBC study of ECOLOGO-certified products. This price has been assumed to hold steady in current dollars (i.e., escalate at the same rate as inflation) for the duration of the study. This would be equivalent to approximately \$625/tCO_{2e} with an electricity grid emissions factor of 40 gCO_{2e}/kWh, and \$250/tCO_{2e} with an electricity grid emissions factor of 100 gCO_{2e}/kWh.

5.2.4.3 Power Purchase Agreements

LBF could also purchase electricity directly from off-site renewable generation, if an appropriate agreement can be reached with a developer. This would involve LBF purchasing its electricity from the grid; the generator selling its electricity to the grid; and an arrangement between LBF entities, the generator, and Hydro Ottawa (i.e., the local distribution company [LDC]) to align the sales volumes. Typically, the LDC would charge an additional fee above what the developer charges for completing this transaction. However, if the system has a positive impact on a localized grid constraint (i.e., is considered a distributed energy resource [DER]), the LDC may share a portion of that value which could potentially lower the price of the purchased electricity.

PPAs can more effectively guarantee the additionality of the electricity generated compared to an REC. For RECs, additionality may have resulted from generation that would have taken place regardless (e.g., to meet renewable energy targets in generation portfolios or for economic reasons). This analysis has assumed that both PPAs and RECs are of appropriately high standards to be considered High Quality offsets and are therefore comparable. Using RECs, PPAs, or a combination would therefore depend on economic and other benefits of each option.

In contrast to RECs, electricity purchased through a PPA is in place of grid electricity rather than incremental to it. To compare prices, the rate paid to the generator and LDC would have to be compared to the rate paid for grid electricity in addition to the REC price. Since the electricity rates and volumes would need to be known with a higher degree of certainty than currently available, and since the decision to use RECs or PPAs would depend on the end user's specific criteria, this analysis has assumed that all renewable



LEBRETON FLATS ZERO CARBON COMMUNITY ENERGY PLAN

Economic Analysis

electricity offsets are achieved with RECs. The following PPA cost estimates are provided for comparison purposes, in case it is desirable to investigate this option further.

Stantec and NCC collaborated with a local non-profit developer, the Ottawa Renewable Energy Co-op (OREC), to develop cost estimates for providing renewable electricity to LBF using NCC land. OREC estimates that the levelized cost of electricity (LCOE) will be approximately \$110/MWh for wind power and \$170/MWh for solar PV power, assuming a typical expected return on capital for the developer, a 6% discount rate, and a 30-year measure life. As this is an LCOE, the price would be stable in real terms over the 30-year life of the generating asset. This would be equivalent to approximately \$3,500/tCO_{2e} with an electricity grid emissions factor of 40 gCO_{2e}/kWh, and \$1,400/tCO_{2e} with an electricity grid emissions factor of 100 gCO_{2e}/kWh.

5.2.4.4 Carbon Offsets

Carbon offset pricing is wide-ranging, reflecting the many approaches to achieving emissions reductions as well as the differences in the cost of the reduction measures and costs to comply with certification protocols. Pricing is also affected by the markets in which they are traded and the supply and demand of offsets. Regulatory uncertainty also adds to the cost and volatility. This makes it challenging to predict the long-term costs of carbon offsets.

Non-RECs carbon offsets can apply to emissions from electricity and on-site fossil fuel combustion. However, for the purpose of this analysis they have been assumed to apply only to on-site fossil fuel combustion, as electricity emissions will be offset using RECs or PPAs. Non-RECs carbon offsets would also be the most likely option for offsetting the embodied carbon associated with the construction and demolition of LBF infrastructure.

For the purposes of this analysis, carbon offsets have been estimated to cost \$25.20/ton CO_{2e}, based on the high end of the Fairtrade⁴¹ minimum prices with an additional 25% buffer. This price has been assumed to hold steady in current dollars (i.e., escalate at the same rate as inflation) for the duration of the study.

5.2.4.5 Social Cost of Carbon

While LBF would only be subject to market prices for carbon, a comparison of these costs against the estimated social costs stemming from carbon emissions can provide insight into discrepancies between market price and societal cost (i.e., the pricing mechanism is not effectively communicating the necessary behavioral change and therefore the negative effects of carbon emissions may be externalized). This would indicate areas where NCC may prefer to affect the necessary change through policy rather than market forces. Various estimates have been made regarding the social cost of carbon, and a detailed review is not

⁴¹ <https://www.goldstandard.org/blog-item/carbon-pricing-what-carbon-credit-worth>, €14/tCO_{2e} for Forest Management projects converted to CAD at 1.44 CAD/Euro. Energy Efficiency and Renewable Energy are €9.20/tCO_{2e}.



LEBRETON FLATS ZERO CARBON COMMUNITY ENERGY PLAN

Economic Analysis

appropriate for this study. However, two relevant examples are cited here. The US EPA⁴² estimates a social cost of carbon as high as \$265 (CAD 2020), comparable to the shadow carbon price of \$300/ton used in PSPC’s internal analysis of carbon reduction measures.

5.2.4.6 Summary

The carbon cost assumptions in this study are summarized below.

Table 5-2: Summary of Carbon Costs

Cost	2025	2030	2050	2075	2100
Federal CO _{2e} Price (\$/tCO _{2e})	\$95	\$170	\$170	\$170	\$170
Federal CO _{2e} Price (\$2020/tCO _{2e})	\$86	\$139	\$93	\$56	\$34
RECs (\$2020/MWh) ¹	\$25	\$25	\$25	\$0	\$0
RECs (\$2020/tCO _{2e}) ²	\$294	\$299	\$262	N/A	N/A
PPAs (\$2020/MWh) ^{2,3}	\$140	\$140	\$140	\$140	\$140
PPAs (\$2020/tCO _{2e})	\$1,649	\$1,675	\$1,468	N/A	N/A
Carbon Offsets (\$2020/tCO _{2e})	\$25	\$25	\$25	\$25	\$25
Social Cost of CO _{2e} (\$2020/tCO _{2e}) ⁴	\$283	\$283	\$283	\$283	\$283

1. Assumed that RECs are not required beyond 2074.
2. Based on the average emissions factor in stated year.
3. Average of solar PV and wind in Ottawa.
4. Average of US EPA and PSPC "shadow" price.

5.3 ECONOMIC ANALYSIS SUMMARY

5.3.1 HVAC Capital Investment

Figure 5-1 below summarizes the capital requirements for each of the six DES configurations, which consist of the two levels of energy efficiency (options A and C) and three HVAC systems (GSHP, 2-pipe DES, and 4-pipe DES). This allows for a more direct comparison between the capital investments required, as some costs will be paid for by the building developer and some paid for by the DES developer. Note that these costs are incremental to the cost of constructing the baseline building.

⁴² Technical Support Document: Technical Update of the Social Cost of Carbon for Regulatory Impact Analysis Under Executive Order 12866 (May 2013, Revised July 2015), 95th percentile climate change scenario, 3% discount rate, 2050.



LEBRETON FLATS ZERO CARBON COMMUNITY ENERGY PLAN

Economic Analysis

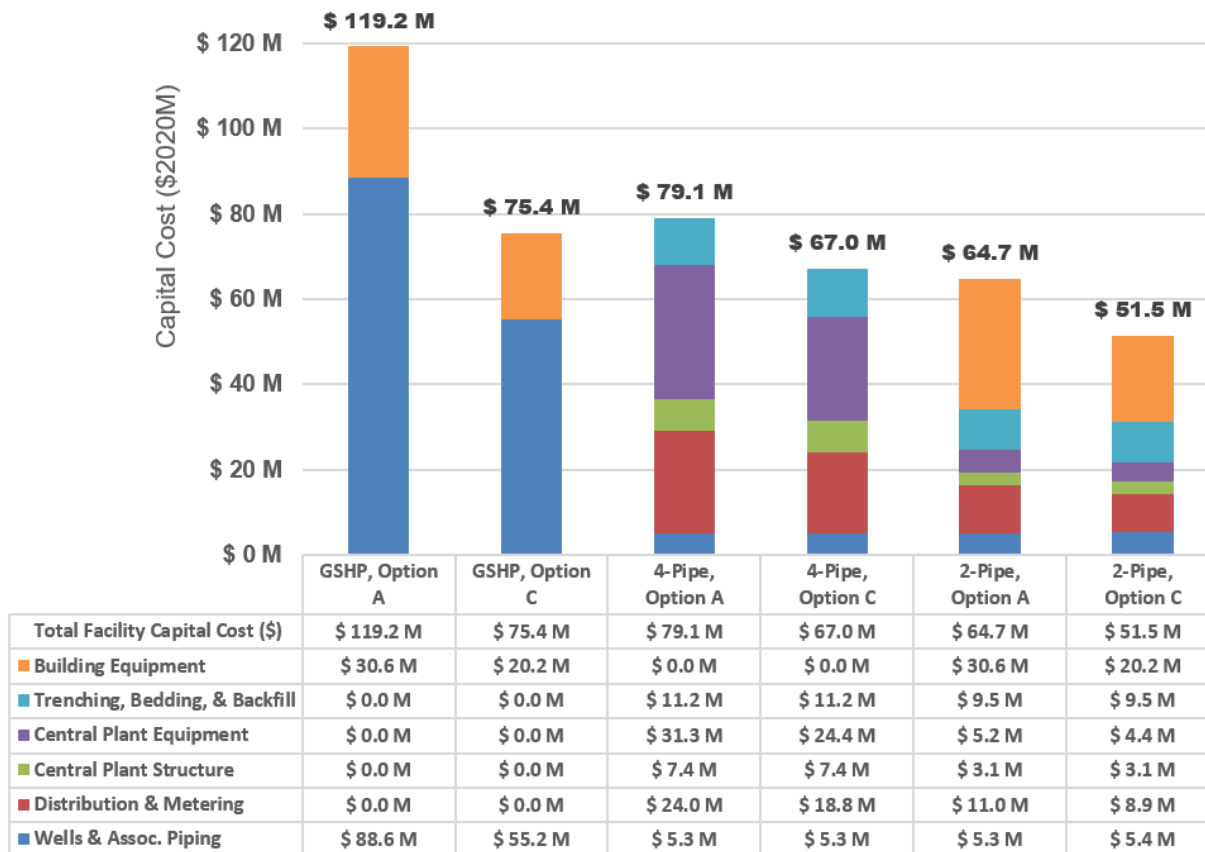

Figure 5-1: HVAC Capital Cost Breakdown (\$2020M)

The capital investment is broken down by the major components of the HVAC system, which helps identify the sensitivity of the overall economics regarding particular input assumptions. If further analysis is taken, more attention should be paid to components that have a larger impact on the results.

The categories included are as follows.

- **Building Equipment:** the costs of installing ground source heat pumps (GSHP) in the buildings.
- **Trenching, Bedding, and Backfill:** the costs of preparing trenches for the DES distribution piping, including excavation, removal of excess material, and recovering the trenches.
- **Central Plant Equipment:** the costs of HVAC equipment, including heat pumps, cooling towers, auxiliary backup systems, pumps, heat exchangers, and controls.
- **Central Plant Structure:** the costs of the building to house the central plant equipment and space for the maintenance personnel to work.
- **Distribution and Metering:** the costs of the infrastructure for transferring thermal energy between the central plant and the buildings, including piping, heat transfer stations for the buildings, and metering equipment. High quality DESs typically include embedded infrastructure for leak detection and monitoring.



LEBRETON FLATS ZERO CARBON COMMUNITY ENERGY PLAN

Economic Analysis

- **Wells and Associated Piping:** the costs to install the geo-exchange field, including wells or boreholes, piping, pumps, and controls.

Project management, design, and contingency fees are included in each of the above categories.

The Option A scenarios are more expensive than the equivalent Option C scenarios, since the more efficient Option C buildings require less installed equipment capacity.

Building equipment cost is primarily the cost of installing GSHPs in the buildings for the GSHP and 2-pipe DES scenarios. The 4-pipe DES has no additional building equipment costs, as all costs have been accounted for in the DES analysis; with the GSHP costs being part of the central plant equipment cost. This equipment is the largest cost component for the 2-pipe and 4-pipe DES. For the building GSHP scenarios, Wells and Associated Piping dominate the costs. These costs are significantly higher than the DES scenarios, due to the need for vertical closed-loop boreholes.

While this exhibit provides a sense of the scale of the investments and how they are allocated between individual buildings and the central DES, it does not account for other costs (e.g., debt servicing and O&M) which are substantial; such costs are presented in subsequent sections.

5.3.2 DES Levelized Cost of Energy (LCOE)

Levelized cost of energy (LCOE) is routinely used in public energy utility planning and analysis, especially when comparing electrical power supply options. However, it can be adapted to any form of utility scale energy, including thermal energy supplied by a DES. LCOE is meaningful when comparing between various energy supply options that deliver standard units of energy (e.g., kilowatt-hours [kWh] of electricity or millions of BTUs [MMBtu] of heat energy).

LCOE answers the following question:
“What level rate must I charge for the energy delivered, over the entire economic life of the project, in order to meet all expenses and earn the targeted (pre-tax) annual rate of return on invested capital?”

It is important to note that LCOE rarely reflects the customer’s rate structure, but rather what the utility must collect from energy sales over the lifetime of the asset to recoup costs and provide a return on investment. As noted in Section 4.2, DES pricing structures typically include fixed and variable costs, and heating and cooling energy may be charged at different rates. Since we are unable to speculate on how a future DES utility at LBF may elect to bill customers, we have calculated what an all-in LCOE

needs to be. This is such that whatever rate structure is actually employed, the revenue generated by the utility (i.e., the costs to the customers) will result in the same overall cost per unit of energy consumed (e.g., \$/GJ). However, we caution against a direct comparison between the LCOE rates presented here and the quoted energy rates of other DES or alternative energy supplies, as they may only include the energy portion and not account for fixed charges which are often substantial.

The LCOE analysis has been conducted for a 60-year period. This is to be consistent with the 60-year analysis recommended for the buildings by CaGBC’s ZCB standard and to account for the development



LEBRETON FLATS ZERO CARBON COMMUNITY ENERGY PLAN

Economic Analysis

phase of LBF from 2025 to 2051 (i.e., where significant capital investments are required in the near term, but energy revenue takes time to ramp-up as buildings are constructed and occupied). It also accounts for the longer-term scenario where all debt servicing payments associated with the initial capital investment have been paid off.

The categories included in the exhibits are as follows.

- **Debt Service Payments:** include principal repayments and interest payments on loans and equity. They are a function of the capital investment costs and the weighted average cost of capital (WACC). The capital costs are the same as those presented in Figure 5-1, minus the Building Equipment category.
- **Electricity Costs:** includes electricity for geo-exchange pumping, GSHPs (4-pipe only), and other central plant needs.
- **Non-Fuel O&M:** consists of capital renewal expenses to upgrade and renew infrastructure and includes labour.
- **Gross Revenue:** the income to the DES from selling a specific volume of thermal energy at the LCOE. The gross revenue increases from 2025 to 2051 as LBF expands, and then remains steady after 2051 as no new development takes place.
- **Cumulative Net Income:** the gross revenue less Debt Service Payments, Electricity Costs, and Non-Fuel O&M.
- **LCOE:** the NPV of the total operating costs of the plant, divided by the NPV of the total energy sales.

Figure 5-2, Figure 5-3, Figure 5-4, and Figure 5-5 summarize the cash flow analysis and the LCOE estimates.



LEBRETON FLATS ZERO CARBON COMMUNITY ENERGY PLAN

Economic Analysis

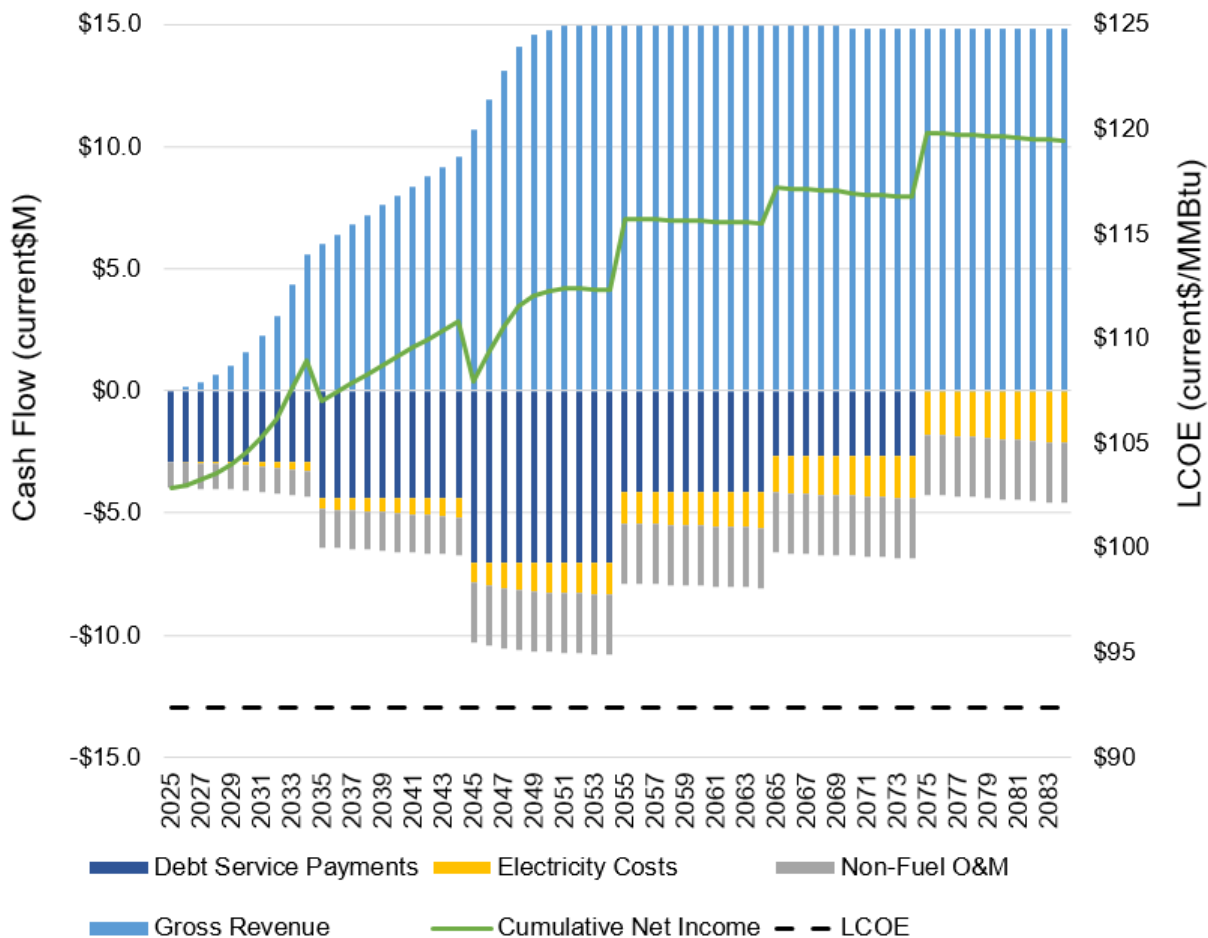

Figure 5-2: Cash Flow 4-Pipe Option A (Current \$M)



LEBRETON FLATS ZERO CARBON COMMUNITY ENERGY PLAN

Economic Analysis

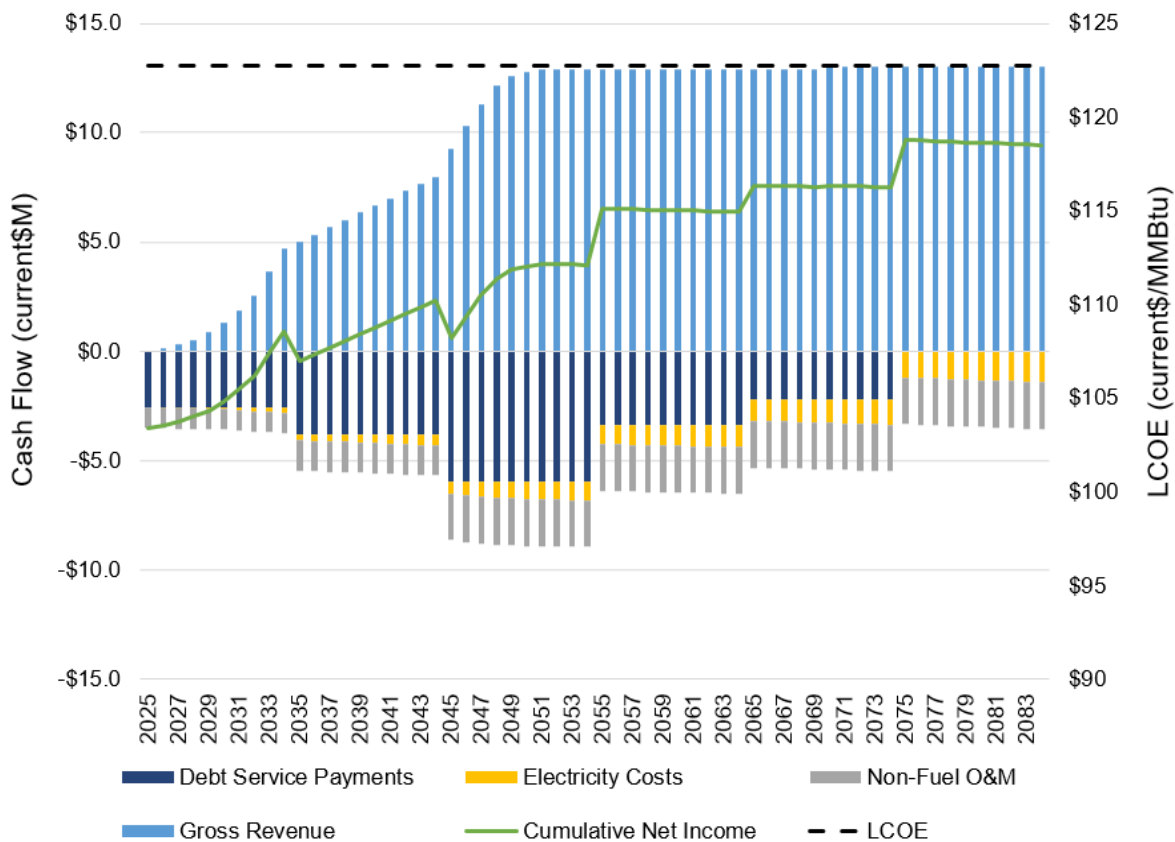

Figure 5-3: Cash Flow 4-Pipe Option C (Current \$M)



LEBRETON FLATS ZERO CARBON COMMUNITY ENERGY PLAN

Economic Analysis

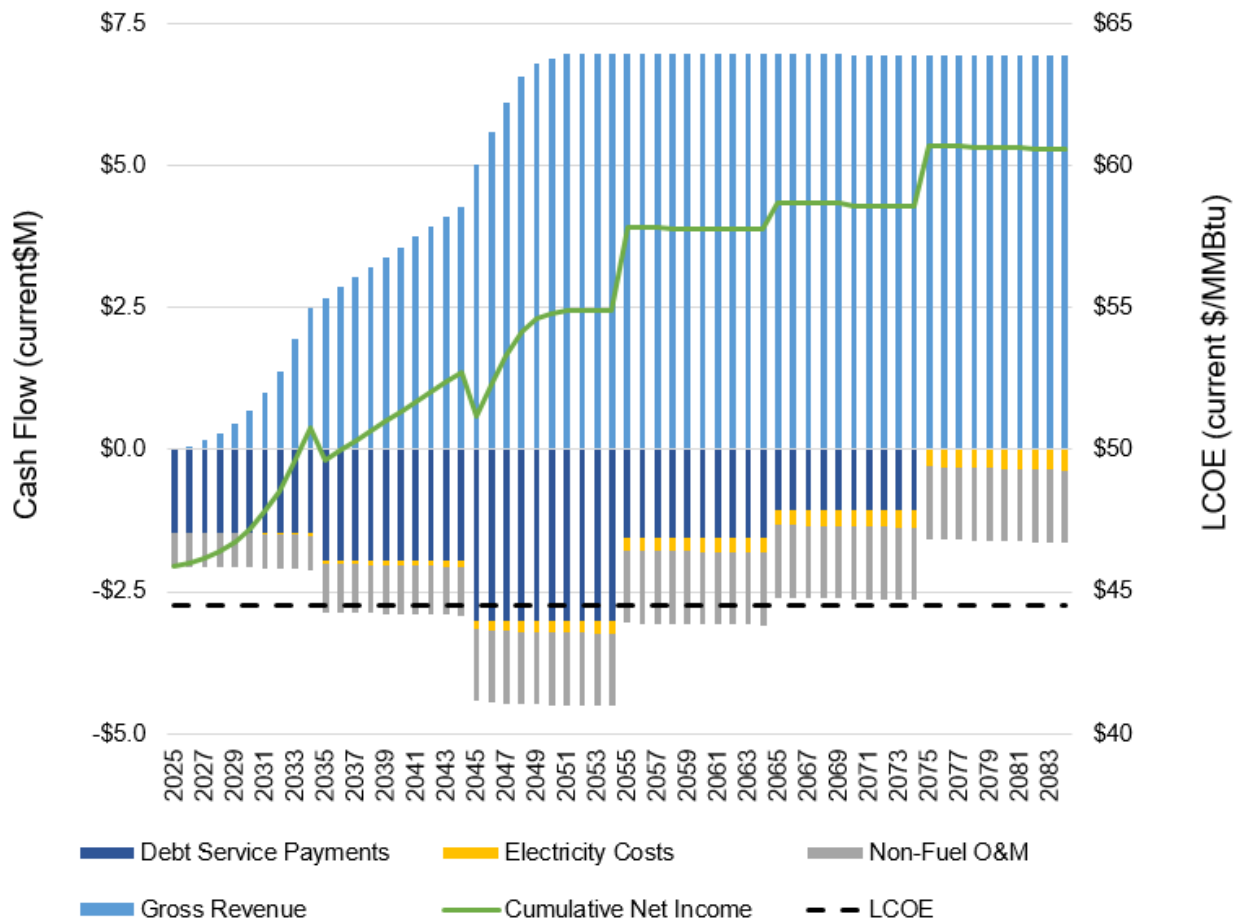

Figure 5-4: Cash Flow 2-Pipe Option A (Current \$M)



LEBRETON FLATS ZERO CARBON COMMUNITY ENERGY PLAN

Economic Analysis

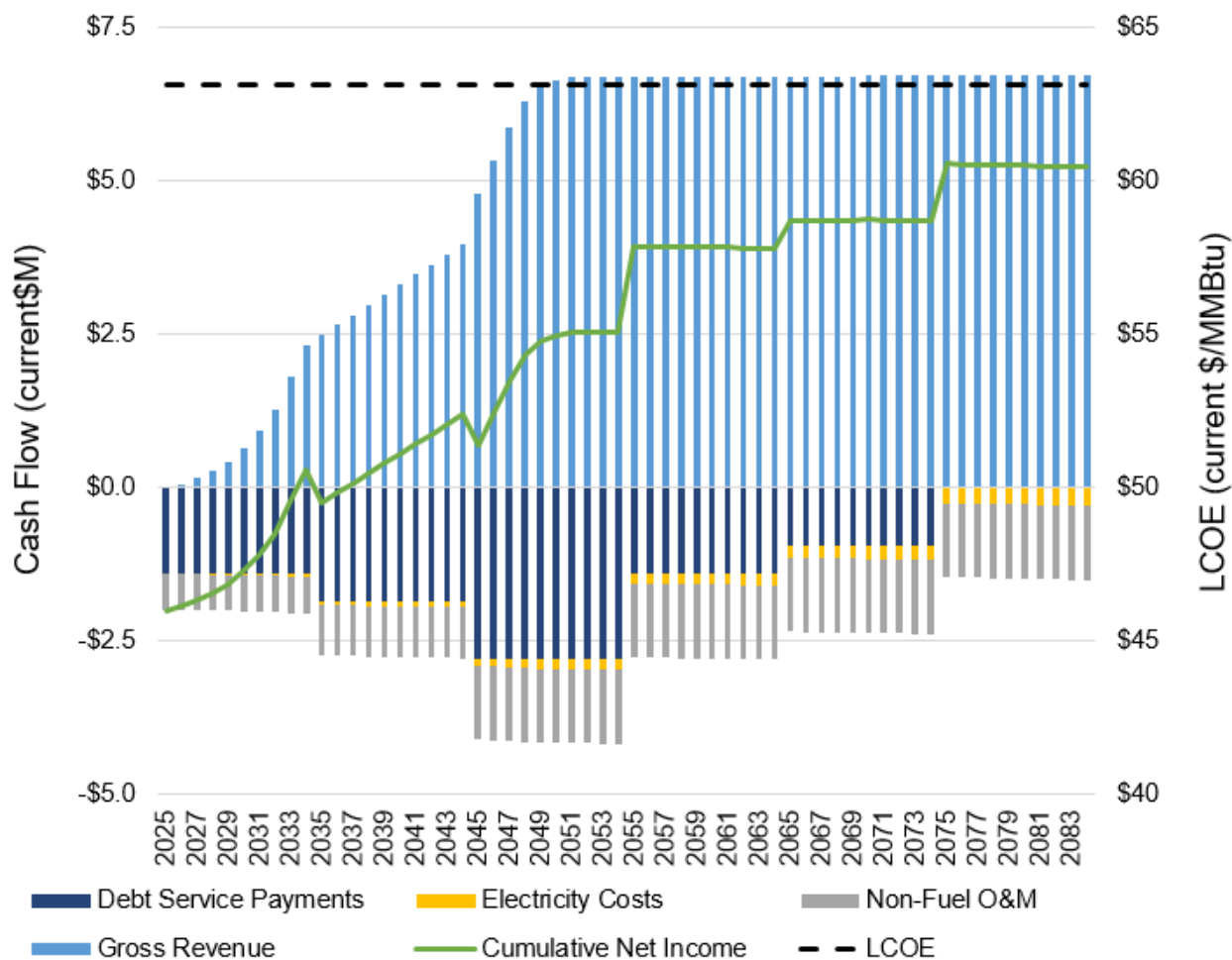

Figure 5-5: Cash Flow 2-Pipe Option C (Current \$M)

It can be observed that in all scenarios, the Debt Service Payments are the most significant contributor to the LCOE, followed by Non-Fuel O&M. Electricity Costs are only a modest contributor to all scenarios, although significantly higher for the 4-pipe DES; this reflects that GSHP energy is included, whereas for the 2-pipe DES, GSHP energy is consumed at the building level.

Table 5-3 below summarizes the DES LCOE rates presented above.

Table 5-3: DES LCOE Rates

LCOE	Option A		Option C	
	2-pipe DES	4-pipe DES	2-pipe DES	4-pipe DES
\$/MMBTU	\$45	\$92	\$63	\$123
S/GJ	\$42	\$88	\$60	\$116



LEBRETON FLATS ZERO CARBON COMMUNITY ENERGY PLAN

Economic Analysis

It can be observed that the 2-pipe scenarios have a much lower LCOE than the 4-pipe scenarios, reflecting the fact that the GSHP infrastructure and operating costs are included in the 4-pipe DES but not in the 2-pipe DES. The LCOE for Option A scenarios is lower than for Option C scenarios, demonstrating that the lower capital investment and O&M for the more efficient Option C scenarios is offset by the lower thermal sales volume (i.e., requires a higher unit cost to provide the same return on investment). This would suggest that in an open market, the DES developer may prefer Option A, as the LCOE would likely be perceived as more cost competitive. This is because this assessment is often based on a simplistic comparison of unit prices; however, a full lifecycle cost analysis of the impacts of energy efficiency would be required to determine whether this is actually the case. If the same thermal sales volume could be guaranteed across all scenarios, it would not matter to the DES developer whether it was the higher Option A volume or the lower Option C volume, as all scenarios provide the same return on investment.

As LCOE is a utility metric, it is only relevant to the costs borne by the DES developer, which will be passed onto the buildings at LBF in the form of charges for the thermal energy (i.e., heating and cooling) consumed by the site. To accurately compare the DES and GSHP scenarios, including the impact of energy efficiency, it is necessary to evaluate the entire urban-level scenario.

5.3.3 Urban-Level Results

This section presents a summary of the economic analysis for the buildings and DES combined, providing an overall view of the urban-level results. Reviewing the building and DES results in isolation provides useful insights into those components, but the results need to be combined to fully understand the urban-level implications. The following scenarios have been considered.

Code-compliant baseline buildings for comparison purposes. Their energy sources are grid electricity and natural gas. These buildings achieve net-zero carbon emissions through the use of RECs for electricity and offsets for natural gas emissions. However, they would not be compliant with CaGBC's ZCB standard, due to the combustion of fossil fuels on-site.

Buildings compliant with the City of Ottawa's HDPS Tier 1 benchmarks for TEUI, TEDI, and GHGI, as described in Section 3.5. Their energy sources are grid electricity and natural gas. These buildings achieve net-zero carbon emissions through the use of RECs for electricity and offsets for natural gas emissions. However, they would not be compliant with the ZCB standard, due to the combustion of fossil fuels on-site.

Option A and C buildings (with differing levels of energy efficiency between them), with the three following options for heating and cooling energy:

- Building-level closed-loop GSHPs
- Two-pipe ambient temperature DES
- Four-pipe DES

Their energy sources are grid electricity, electricity generated on-site, and renewable natural gas. These buildings achieve net-zero carbon emissions through the use of RECs for electricity and are considered



LEBRETON FLATS ZERO CARBON COMMUNITY ENERGY PLAN

Economic Analysis

compliant with the ZCB standard, as no fossil fuel is combusted on-site and RNG is only used for food-service loads.

The NPV calculation includes the following categories.

- **Incremental Construction Cost:** the incremental cost of constructing the buildings compared to a code baseline, capturing costs of energy improvements but neglecting costs that do not impact energy use. Equipment located within the buildings (e.g., GSHPs for the 2-pipe DES and building GSHP scenarios) are included in this category, but not the capital costs associated with the DES, which are captured in the DES Thermal Energy costs.
- **Building Electricity:** the cost of electricity purchased by the buildings, both residential and commercial. It does not include the cost of electricity purchased by the DES, as this is captured in the DES Thermal Energy costs. The total cost is determined by multiplying the electricity consumption in each year (as summarized in Section 4.1.9) by the electricity rates (as summarized in Section 5.2.3).
- **Natural Gas/RNG:** the cost of natural gas and RNG purchased by the buildings, both residential and commercial. The total cost is determined by multiplying the natural gas and RNG consumption in each year (as summarized in Section 4.1.9) by the appropriate rates (as summarized in Section 5.2.3).
- **Water and Sewer:** the cost of water purchased by the buildings, both residential and commercial. The total cost is determined by multiplying the water consumption in each year (as summarized in Section 4.1.9) by the water and sewer rates (as summarized in Section 5.2.3).
- **DES Thermal Energy:** the cost of DES thermal energy purchased by the buildings. The total cost is determined by multiplying the thermal energy consumption in each year (as summarized in Section 4.2.1) by the DES LCOE (as summarized in Section 5.3.2).
- **Non-Utility O&M:** the costs of operation and maintenance except for the utility costs above, including labour and capital renewal (as summarized in Section 5.2.1 and Section 5.2.2).
- **Carbon Offsets:** the costs of purchasing carbon offsets to balance out the emissions associated with operational carbon emissions (i.e., carbon emissions from energy consumption) so that all scenarios are net-zero carbon. This includes RECs and non-RECs offsets. The total cost of RECs is determined by multiplying the electricity consumption in each year (as summarized in Section 4.1.9) by the RECs price (as summarized in Section 5.2.4.2). The total cost of non-RECs offsets is determined by multiplying the natural gas consumption in each year (as summarized in Section 4.1.9) by the RECs price (as summarized in Section 5.2.4.4).



LEBRETON FLATS ZERO CARBON COMMUNITY ENERGY PLAN

Economic Analysis

Figure 5-6 below summarizes the results.

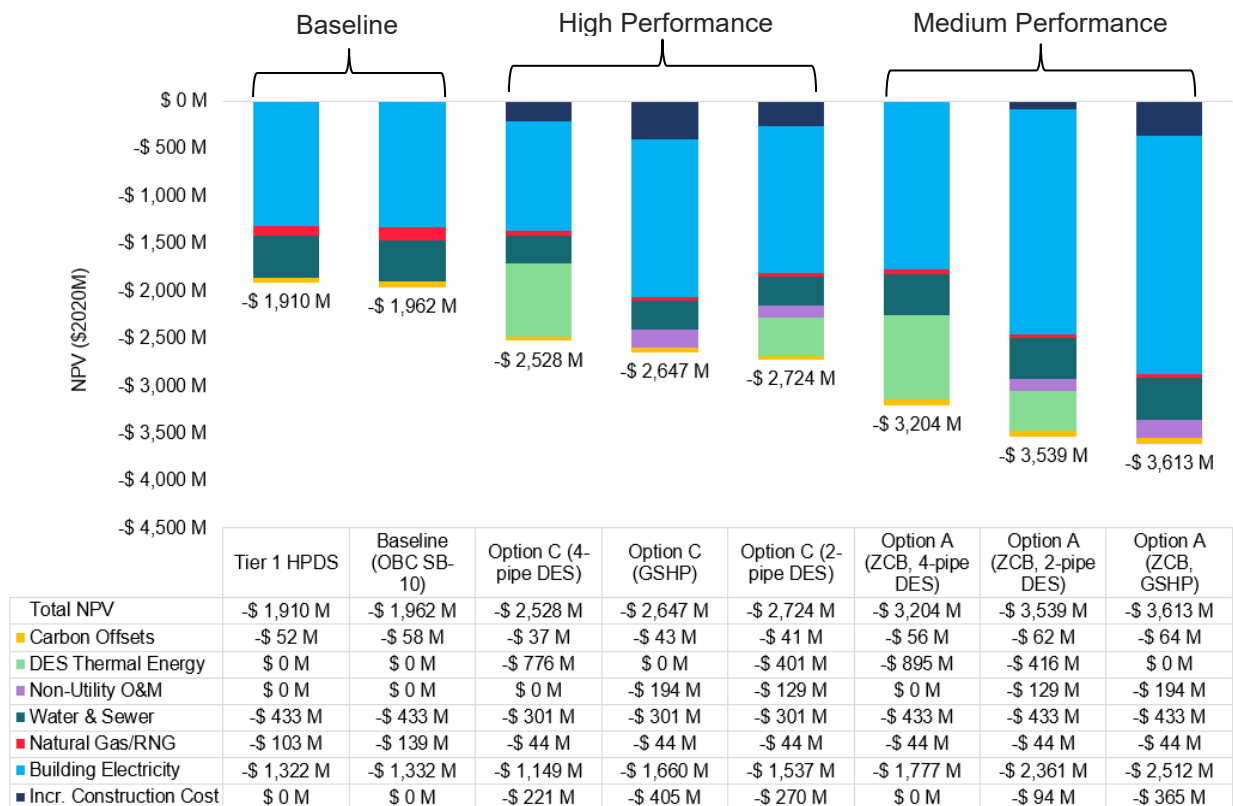

Figure 5-6: Net Present Value of Urban Scenarios

The following conclusions can be drawn from the analysis:

- Even with carbon offsets included, the Tier 1 and Code compliant (OBC SB-10) buildings are cheaper to build and operate than buildings that have eliminated on-site combustion of fossil fuels. This indicates that the current and forecast market price of carbon is insufficient to propose the elimination of fossil fuel use, since offsets provide a cheaper option.
- Option C buildings spend less on DES thermal energy compared to Option A buildings, despite the fact that the LCOE of DES thermal energy is higher for the Option C scenarios. Essentially, the reduced energy requirements of Option C buildings compared to Option A buildings offsets the higher unit cost of energy.
- The utility savings for the Option C scenarios significantly offset the higher capital cost compared to the Option A scenarios, providing a positive return on investment for the sustainability measures.
- Within each level of building efficiency (i.e., Option A and Option C), the differences in NPV between the three HVAC options (GSHP, 2-pipe DES, and 4-pipe DES) are modest, and can be considered to have an equal NPV within the margin of uncertainty of the analysis.



5.3.4 Sensitivity Analysis

Sensitivity analysis is a method for estimating the impact of uncertainty in a model's inputs on the final results. For the purposes of this analysis, it can be used to estimate the impact that altering cost input assumptions will have on the estimated NPV of the three HVAC options (i.e., GSHP, 2-pipe DES, and 4-pipe DES). Only the Option C options have been evaluated, as they are significantly more cost effective than the Option A scenarios (see Figure 5-6). As such, Option A should not be considered further. In addition, it is necessary to ascertain whether or not the conclusion that the three HVAC options provide the same NPV within the margin of uncertainty holds when the uncertainty is adjusted.

To conduct a useful sensitivity analysis, it is necessary at this stage to determine which inputs have a significant effect on the final outcomes, and the uncertainty associated with those inputs. Altering parameters with a small impact will not significantly alter the final results. Altering parameters that have a large impact but are not expected to vary significantly from current forecasts (i.e., have a high degree of certainty associated with their estimated values) will also have a limited impact.

Figure 5-7 below summarizes the NPV of the three HVAC options, broken down by the largest contributors. To provide a fair comparison between the building and DES components, they have been compared using the DES discount rate, as described in Section 5.2. This means that these results are not directly comparable to those shown in Figure 5-6, which uses different discount rates for building and DES investments.



LEBRETON FLATS ZERO CARBON COMMUNITY ENERGY PLAN

Economic Analysis

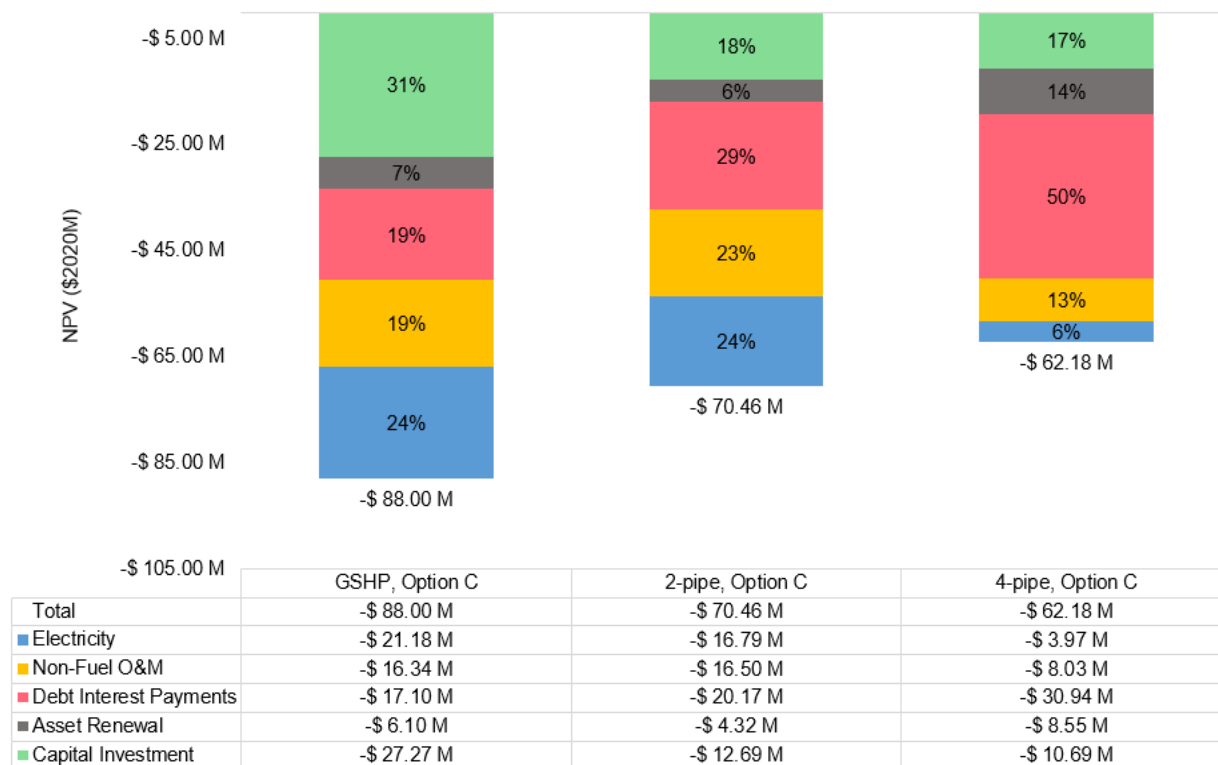

Figure 5-7: Net Present Value of HVAC Options

It can be observed that the most important input parameters are the capital costs (i.e., affecting the Capital Investment and Asset Renewal costs), the weighted average cost of capital (affecting the Debt Interest Payments), the Non-Fuel O&M costs, and the Electricity costs. A summary of how these parameters are expected to vary is provided below.

- Capital Costs:** These costs contribute between 24% and 38% of the overall NPV. At this stage of the analysis, the capital costs have been estimated to a pre-feasibility level of certainty and can be considered to be within 30% of the final construction cost estimates. Therefore, the Capital Investment and Asset Renewal costs have been varied by -30% and +30% for the sensitivity analysis.
- Weighted Average Cost of Capital (WACC):** These costs contribute between 19% and 50% of the overall NPV. The WACC estimate employed for this study can be considered to be at the higher end of the range of estimates, since it has been based on a private sector DES developer who would have higher borrowing costs and a higher expected rate of return on equity than an institutional developer. Therefore, the Debt Interest Payments have been varied by -50% and +10% for the sensitivity analysis. Note that the Debt Interest Payments cascade from the Capital Investment adjustments noted above, as the interest payments are a function of both the principal amount (i.e., debt and equity), which depends on the capital costs and the WACC.
- Non-Fuel O&M:** These costs contribute between 13% and 23% of the overall NPV. They can be considered to have a pre-feasibility level of certainty but are known to a higher degree of certainty



LEBRETON FLATS ZERO CARBON COMMUNITY ENERGY PLAN

Economic Analysis

than the capital cost estimates as there are significantly less inputs. Therefore, the Non-Fuel O&M costs have been varied by -15% and +15% for the sensitivity analysis.

- Electricity:** These costs contribute between 6% and 24% of the overall NPV. The overall trend for electricity costs can be considered to be known to a high degree of certainty, as they are based on forecasts made by the IESO (i.e., the entity that oversees Ontario’s electricity market and plans for future energy needs). However, how these broader price trends will translate to the rates charged to individual customers is less certain. Additionally, there will be a blend of residential and commercial customers at LBF with different rate structures. Design decisions by future developers could also significantly alter this distribution. For example, a developer could install multiple distributed in-suite heat pumps that are subject to a residential rate, or they could install a single, central heat pump in the mechanical room subject to a commercial rate. Therefore, the Electricity costs have been varied by -25% and +25% for the sensitivity analysis.

Figure 5-8 below summarizes the results of the sensitivity analysis.

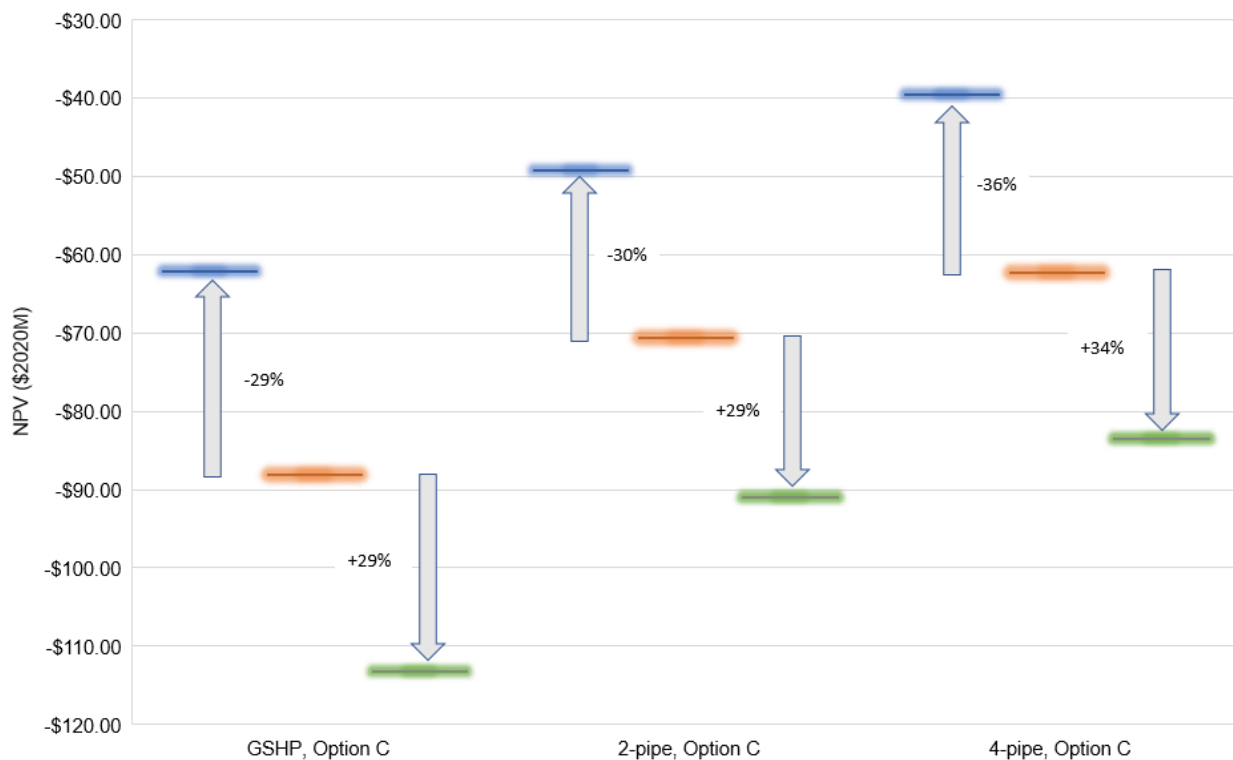

Figure 5-8: Effect of Sensitivity Analysis on HVAC Options

It can be observed that the overall results vary from -36% to +34%, with the largest impact being on the 4-pipe DES scenario. This is because this scenario is most dependent on the Debt Interest Payments portion of the estimate (i.e., approximately 50% of the total NPV and a function of both the capital cost and WACC estimates, both of which have the highest degree of uncertainty in the model). The GSHP and 2-pipe DES scenarios vary by -30% to +29% (i.e., a smaller range than the 4-pipe DES). This shows that their costs



LEBRETON FLATS ZERO CARBON COMMUNITY ENERGY PLAN

Economic Analysis

are more evenly distributed among the input parameters, with no single input contributing more than 31% to the overall result.

With reference to Figure 5-6, the HVAC system costs are only a portion of the overall urban-level costs, which also includes the capital costs of non-HVAC improvements vs. code (e.g., envelope and lighting) and the utility costs for operating non-HVAC equipment (e.g., lights and plug loads). Overall, the HVAC system costs make up between 31% and 34% of the overall urban costs, which means that the effect of the sensitivity analysis on the overall urban level results are reduced to (at most) approximately 15%. This is demonstrated in Figure 5-9 below.

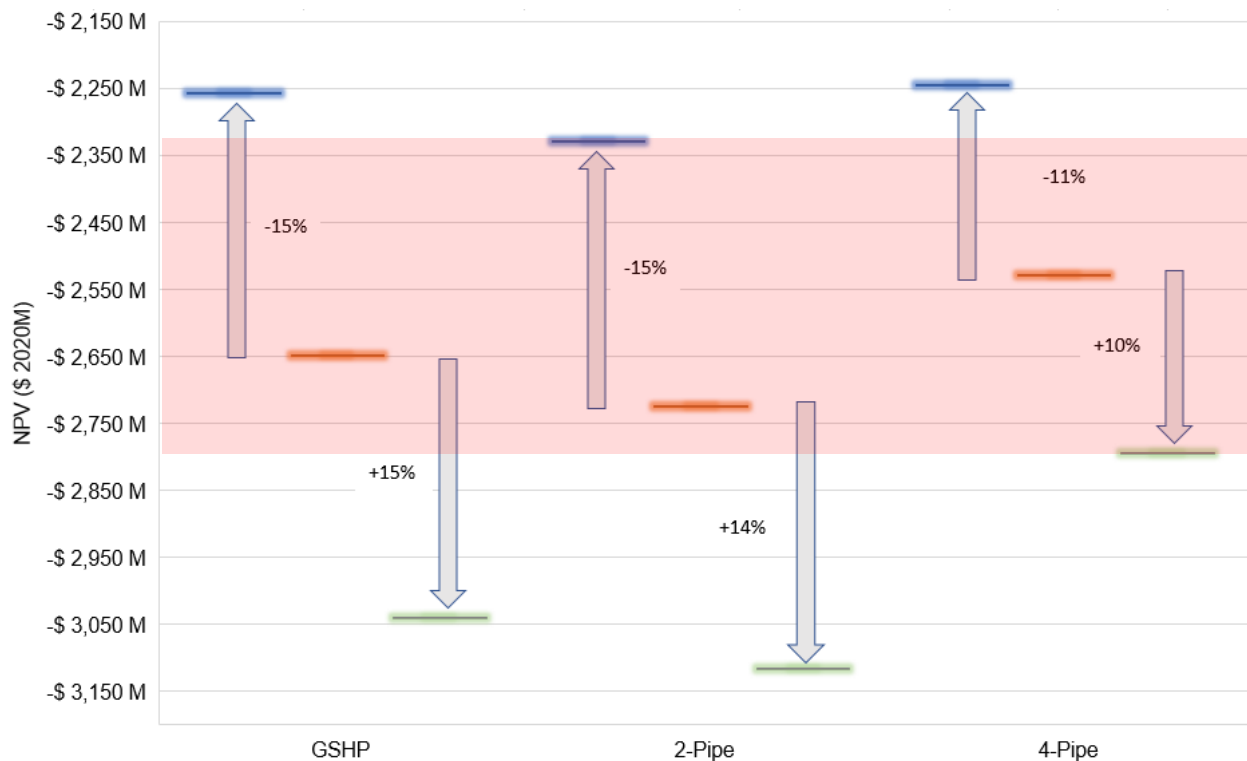

Figure 5-9: Effect of Sensitivity Analysis on Urban Scenarios

It can be observed when reviewing the sensitivity analysis at the urban scale that the results presented are all within the lower boundary limits of the sensitivity parameters, therefore confirming that the conclusion formed from Figure 5-6 where the differences in NPV between the three HVAC options are indeed modest and effectively equal. The sensitivity analysis demonstrated that although there is a level of uncertainty in the economic analysis, it is within the acceptable range for a pre-feasibility analysis and the results are sufficient to allow for conclusions to be made about the Community Energy Plan for LBF. The objective of the economic analysis is not to provide a highly accurate forecast of possible financial outcomes, but rather to provide insights for creating a framework that can support the development of LBF as a net-zero carbon community while understanding the economic implications. The results of the sensitivity analysis demonstrate that this objective has been achieved.



6.0 CONCLUSIONS AND RECOMMENDATIONS

This section summarizes the conclusions and recommendations resulting from the analysis undertaken to develop the Community Energy Plan for LeBreton Flats.

- **Building Performance Targets:** The results of the economic analysis presented in Section 5.0 support pursuing energy efficiency and electrification to the fullest extent, consistent with CaGBC's ZCB framework. The analysis also demonstrates that regardless of which HVAC system is employed (GSHP, 2-pipe DES, or 4-pipe DES), the scenario is improved with maximum energy efficiency. The results of Section 4.1 also demonstrate that meeting Zero Carbon performance levels is achievable for all building archetypes using readily available technologies and construction practices. It is therefore recommended that the energy performance targets of TEUI and TEDI be set consistent with ZCB. The incremental construction costs for high performing buildings are less than 5% higher than that of a comparable code standard building, costs which are easily recovered through the higher sale price commanded by high performance buildings, or through increased rent and O&M savings in the case of an owner/operator. It is not recommended to specify any additional performance targets such as the fraction of onsite solar PV or specify that specific technologies be employed to meet the specified targets. These decisions are better left to the building developer to determine at the time of detailed design and construction.
- **Building Design Approach:** Best practices for achieving net-zero carbon in the built environment prioritize reducing loads through passive measures such as improved envelope components first, then employing high efficiency systems for HVAC loads, lighting, and plug loads (which often includes switching to lower carbon fuel sources), optimizing control strategies, and finally generating renewable energy onsite. Any remaining carbon is offset through offsite renewables or other forms of carbon offsets. The challenge is in determining how much of the carbon reduction to achieve through energy efficiency, fuel switching, and offsets. The results of the analysis summarized in Section 4.1 has provided detailed recommendations for how to achieve this balance in a cost effective and relatively easy to implement manner for building developers. This information could be shared with building developers undertaking projects at LBF.
- **HVAC Options:** The results of the NPV for Urban Scenarios presented in Section 5.3.3 identify that the economic performance between HVAC options (GSHP, 2-pipe DES, and 4-pipe DES) are all effectively equal at this early stage of analysis. This conclusion results in consideration of non-financial factors to support further energy generation recommendations. When comparing building only energy generation versus DES, 4-pipe DES shows the most promise for onsite generation and waste heat recovery, providing high system resiliency potential and the lowest level of effort and capital investment for building developer connection. DES connection to either a new DES or existing nearby DES is also consistent with the City of Ottawa's proposed High-Performance Development Standard (HPDS) Tier 2 category. Consequently, the 4-pipe DES is considered to the best option for LBF.



LEBRETON FLATS ZERO CARBON COMMUNITY ENERGY PLAN

Conclusions and Recommendations

- **DES Ready Framework:** Pursuing DES for LBF as the preferred choice of HVAC solution will require the addition of a mandate for DES connection of all land parcels released for development. This reality must be upheld to support any of the financial analysis presented above. In order to accommodate the earlier stages of development, a “DES ready” mandate can be created whereby buildings are constructed with the ability to connect to a future DES with temporary thermal energy systems serving these loads in the interim. Once the DES is ready and building connection has been achieved, these temporary systems can be retired or incorporated into the DES, either as primary or backup systems. This arrangement will allow buildings to be developed on a quicker timeframe than would be allowed if a DES was required to be operational first, while still ensuring that the benefits of the DES are captured in the longer term. Additionally, any DES serving LBF must be required to provide net-zero carbon energy to the site, using industry best practice carbon accounting and offset approaches. This will simplify the ZCB certification process for buildings and provide an incentive to DES developers to explore more innovative and cost-effective approaches to achieving net-zero carbon.
- **Infrastructure Planning:** From an overall land parcel development perspective, long term site development benefits of managing optimized energy generation, such as geo-exchange and waste heat recovery, in a consolidated area of the development. Consolidated geo-exchange avoids the future challenges of built for purpose, standalone geo-exchange scattered throughout the development with low potential for future reuse. Implementation of DES infrastructure in parallel with new city infrastructure is also a large opportunity to optimize DES distribution costs which would improve the business case for DES from what this analysis has estimated.
- **Net-Zero Carbon Frameworks:** Because of how carbon intensive our society is at present, it would be extremely challenging to develop LBF as a zero-carbon community, with no carbon emissions associated with development. Recognizing this, the goal should be to achieve net-zero emissions where upfront emissions from construction, as well as ongoing operational emissions from energy consumption, are balanced out with carbon offsets. Net-zero carbon frameworks are complicated, especially with respect to the rapidly evolving carbon offsets space, so following industry leading guidelines such as CaGBC’s Zero Carbon Buildings (ZCB) framework and the Science Based Targets Initiative (SBTi) is recommended. These guidelines provide recommendations on procuring the high-quality offsets that will required for LBF to achieve net-zero performance.
- **Quality of Carbon Offsets:** The economic analysis of urban level scenarios shows that the most cost-effective way (i.e., the scenario with the highest NPV) to achieve net-zero carbon is to consume fossil fuels onsite and use non-RECs carbon offsets to achieve the required emissions reductions. However, this approach is not recommended as it is inconsistent with the industry leading net-zero carbon frameworks and is also dependent on the price of carbon offsets being significantly lower than the estimated social cost of carbon, meaning that a significant portion of the carbon cost is being externalized (i.e., not being paid by the end user). As well as being detrimental to society overall, this creates a risk for the end user that the price of carbon offsets may rise significantly or that the use of such offsets may be prohibited or curtailed by legislation. This would create a significant future “carbon liability” for the owners and tenants at LBF. In the language of net-zero carbon frameworks, these would not be considered “high quality” offsets. Therefore, the



LEBRETON FLATS ZERO CARBON COMMUNITY ENERGY PLAN

Conclusions and Recommendations

LBF development should be required to minimize the required carbon offsets to the greatest extent under the guidance of the ZCB framework, and only procure high quality offsets consistent with industry best practices.

- **Grid Peak Impacts:** Many sustainability strategies focus on electrification without adequately accounting for the impacts of adding peak load to the electricity grid, an approach that is inconsistent with frameworks such as ZCB which emphasize the importance of peak demand reduction. In Ottawa, the electrical load required to heat during the coldest hours is substantial, and as the trend for building electrification continues, the need to add generation, transmission, and distribution infrastructure to the electricity grid will be significantly increased. This could create many negative externalities including increased costs for ratepayers, increasing grid unreliability during a time of growing extreme weather events, and increased use of fossil fuels to generate electricity during peak periods. Two strategies should be pursued to mitigate these issues:
 - All development at LBF should be undertaken in close collaboration with Hydro Ottawa who can advise on the impacts that the development will have on the local distribution and transmission system infrastructure, any upgrades that may be required, and the possible financial benefits of distributed energy resources such as onsite electricity generation and electrical and thermal storage.
 - RNG should be an option for limited periods of peak space heating, which would significantly reduce the electricity peaks while providing a small fraction of annual energy needs. This reduction in peak loads would improve both the resiliency of the electricity grid, but also the resiliency of the buildings at LBF as they would have an alternative heating source available during grid outages. As noted in Section 4.6.6, RNG is already a viable zero carbon option for serving food service loads and can therefore easily be included in the energy supply mix for space heating. A DES mandate would shift the responsibility to achieving a net-zero carbon heating system to the DES developer and would therefore make it easier for building owners and operators to achieve ZCB certification.
- **Emissions Factors:** As described in Section 3.9.1, credible long-term forecasts of the carbon intensity of Ontario's grid electricity shows a substantial increase in unit emissions due an increase in natural gas fired generation to compensate for the retirement and refurbishment of the nuclear-powered fleet over the next few decades, as well as to meet growing electricity demand. Since LBF's primary source of electricity will be Ontario's grid, accurately quantifying these emissions will be important. Additionally, ESAP and ZCU, possible candidates for supplying district energy to LBF are relying on low emissions grid electricity supplied by Hydro Quebec to achieve a significant portion of their carbon reductions, complicated by the fact that any loads added directly to the winter peak could have substantially higher marginal emissions to that suggested by the grid average, due to load shedding strategies employed by Hydro Quebec (see Section 3.9.3). For this reason, it is recommended that a detailed analysis of the true marginal carbon emissions from development at LBF be undertaken during the detailed design phase of the buildings in order to more accurately quantify the operational carbon emissions of the site.
- **Additional Energy Elements:** Of all of the additional energy elements evaluated in section 4.6, off-site renewable generation on NCC owned land and sewer waste heat recovery have been



LEBRETON FLATS ZERO CARBON COMMUNITY ENERGY PLAN

Conclusions and Recommendations

identified as good candidates for cost-effective and sustainable energy sources for LBF and should be investigated further by NCC with a view to sharing the findings with building and DES developers. Further evaluation of the other energy elements such as onsite electricity generation, electrical and thermal storage, and process load waste heat recovery should be left to the building and DES developers to evaluate at the detailed design phases of the project.

- **Additional Sustainability Elements:** Since design decisions made at the building level have broader sustainability implications for the wider community, some of these aspects were briefly considered in this report, although it was not within the core mandate of the study. The best way for NCC to encourage the development of these initiatives is through mandating compliance with suitability frameworks such as ZCB which further encourage building developers to pursue industry leading certifications such as LEED and WELL. Under these frameworks, developers have the flexibility to pursue the sustainability options that make the most sense for each building at the detailed design phase, which is a better approach than creating prescriptive requirements several years prior to development which may not be relevant to a specific building or location.



7.0 NEXT STEPS

This section summarizes the next steps that are proposed to support the development of LeBreton Flats in a manner that is consistent with the findings of the Community Energy Plan.

- **The Community Energy Plan (CEP)** for LBF should include the following elements:
 - **Building performance targets** consistent with CaGBC's Zero Carbon Building (ZCB) framework will be adhered to by the building developers.
 - A **DES Ready framework** that includes a requirement that all buildings connect to LBF's District Energy System (DES) once the DES becomes operational. In the interim, building developers will design to be "DES ready".
 - A **DES procurement** strategy whereby development and operation of the DES serving LBF will be undertaken by a competent 3rd party DES developer to be selected by NCC.
- **Building Performance Targets:** The CEP's mandate for building performance can be achieved by directing building developers to follow the CaGBC's Zero Carbon Building (ZCB) framework. Developers should follow the ZCB Design standard during the design phase, and then follow the Performance standard for existing buildings during the occupancy phase. This will ensure that the development will achieve the performance targets recommended by this study while allowing flexibility in design choices by the developer with the support of CaGBC resources. The building design recommendations of this report can also be shared with building developers to provide further guidance. Buildings that achieve ZCB certification often also pursue other sustainability certifications such as LEED and WELL, which encourages incorporating additional sustainability initiatives beyond reduced carbon emissions.
- **DES Ready Framework:** In order to balance the need to begin developing non-contiguous parcels at LBF over a long timeframe with the DES requirements for density and certainty of load, the recommended approach for NCC is to establish a net-zero carbon "DES ready" framework that includes the following elements:
 - The CEP will mandate that the space heating and space cooling loads of all buildings are supplied by a DES. This will provide a reasonable level of certainty to DES developers that they will be able to secure a return on their investment at LBF.
 - Prior to completion of the DES, building developers will design to be "DES ready", whereby buildings will be designed to be integrated with the future DES once it becomes operational and will service their heating and cooling loads with onsite generation in the interim.
 - Once the DES is operational, a DES ready design will no longer be required, and building developers can work directly with the DES operator to design for connection to the DES.
 - NCC will begin the process of procuring a DES developer to build and operate the DES that will be required to serve the entire LBF development.



LEBRETON FLATS ZERO CARBON COMMUNITY ENERGY PLAN

Next Steps

- **DES Procurement:** NCC should immediately begin the process of securing a DES developer to build and operate the DES for LBF. This should consist of the following elements:
 - **Owner's Representative:** As a first step, NCC should secure the services of a knowledgeable and independent 3rd party expert who can support them during the DES procurement process. The Owner's Representative should have expertise in high performance buildings, net-zero carbon, and DES, as well as being familiar with the vision for the proposed LBF development.
 - **Request for Information/Qualifications (RFI/RFQ):** NCC should invite DES developers and other knowledgeable stakeholders to participate in an RFI/RFQ process to provide input on the planned DES and to gather information about the capabilities of potential DES developers who will participate in the RFP process. This could take the form of issuing RFI/RFQ documents and receiving responses, as well as stakeholder workshops.
 - **Request for Proposal (RFP):** NCC and the Owner's Representative should create an RFP that incorporates the findings of the RFI/RFQ process and invite qualified and interested DES developers to respond.
 - **DES Developer Selection:** The final step for NCC will be the selection of the DES Developer whose proposal provides the best overall value for LBF. Once a contractual agreement has been reached between NCC and the DES Developer, NCC can decide how much involvement they want to continue to have in the DES.
 - **Post Procurement:** Following DES Developer selection, construction of Phase 1 of the DES can begin, followed by integration of the existing DES ready buildings into the DES network. Subsequent to this, buildings will no longer need to be DES ready, and will be able to connect to the DES during construction.

- **DES Characteristics:** There are several DES characteristics that will need to be determined during the procurement process in support of the DES ready framework, as well as attributes specific to LBF's DES that are required to meet the sustainability objectives set for the development. These items should be discussed with DES developers throughout the procurement process and should also form part of the selection criteria for the successful DES developer. The analysis undertaken in this report will be useful to DES developers in this regard. The following items should be considered:
 - The **design parameters for the buildings to be DES ready**, e.g., supply and return temperatures for heating and cooling loads, will need to be developed in consultation with DES and building developers, and shared with building developers as soon as possible in the process so that they can be incorporated into building design.
 - **Strategies and timelines for full conversion to DES** from DES ready with the least disruption and cost, e.g., how best to design for future conversion, how to address sunk costs of DES ready infrastructure or integrate the infrastructure into the DES post conversion.
 - The **expected LCOE** of the thermal energy, and recommendations for how this should be translated into an appropriate rate structure for customers, e.g., breakdown of fixed costs and variable costs.



LEBRETON FLATS ZERO CARBON COMMUNITY ENERGY PLAN

Next Steps

- The DES developer must propose a **credible framework for achieving net-zero carbon emissions from the DES** in a reasonable timeframe and be responsible for providing net-zero carbon thermal energy to the site. This includes providing credible forecasts for the long-term carbon emissions intensity of all energy sources for the DES and following industry best practices for procuring carbon offsets. The DES developer should collaborate with the local distribution company (Hydro Ottawa and/or Hydro Quebec) to determine appropriate marginal emissions factors and not simply rely on average emissions factors.
- The DES developer should work with the local distribution company to develop **strategies for mitigating distribution, transmission, and generation constraints** related to the DES heating and cooling loads. This includes both energy supply and the marginal emissions factors associated with it, as marginal emissions are typically higher than average. Strategies identified as good candidates include using RNG to generate thermal energy during electrical peaks and the use of thermal storage to facilitate demand response (DR) measures.
- The DES developer should **consider the additional energy and sustainability elements** evaluated in this report for inclusion as part of the DES. Development of off-site solar on NCC owned land under a Power Purchase Agreement (PPA) and sewer waste heat recovery have been identified as good candidates based on a pre-feasibility screen.
- **Data Collection and Sharing:** NCC can further advance the sustainable development of LBF through the following activities:
 - **Geo-exchange Potential:** Given that there is a good potential for developing a geo-exchange system at LBF, whether for individual building GSHP, a new DES located at LBF, or to expand and decarbonize the existing DESs of ZCU and ESAP to serve LBF, further detailed geotechnical analysis should be undertaken at LBF. This should include evaluating both the potential of closed loop vertical well and open loop systems. ESAP could be a possible partner in this endeavor as they are already considering undertaking geothermal testing at LBF. This information can then be shared with any parties interested in undertaking DES development at LBF, providing greater certainty for the developers' load and cost estimates.
 - **Sewer Waste Heat Recovery:** Collecting better estimates of the temperature and flow rates of the sewage from the collectors located near LBF in order to develop better pre-feasibility estimates of the sewer waste heat recovery potential at the site. This should be undertaken in collaboration with the City of Ottawa. This information can then be shared with any parties interested in undertaking DES development at LBF, providing greater certainty for the developers' load and cost estimates.
 - **Off-site Renewable Electricity Generation:** Evaluating the potential for renewable electricity generation on NCC owned land which could be used to provide renewable energy credits (RECs) for LBF or other entities. Pre-feasibility estimates indicate that such developments could be a cost-effective way to provide net-zero carbon electricity to the site. NCC can work with renewable electricity generators such as the Ottawa Renewable Energy Co-op (OREC) to develop better pre-feasibility estimates which can then be shared



LEBRETON FLATS ZERO CARBON COMMUNITY ENERGY PLAN

Next Steps

with developers to support them in deciding which carbon offset procurement strategy to take.

- **Alternative Funding Sources:** Grants and low interest loans could have a significant impact on the potential to develop district energy at LBF. NCC should begin consulting with knowledgeable parties about possible sources of funding and what their experience was in attempting to secure funding, as well as entities that may be able to provide funding. Good candidates to begin this consultation with include ZCU, ESAP, Hydro Ottawa, Enbridge, and FCM. This information can then be shared with any parties interested in undertaking DES development at LBF.
- **Leveraging the CEP:** The findings of this report can be shared with any parties interested in undertaking development at LBF. Section 3.0 provides guidance on designing for future climate scenarios and best practices for carbon offsets. Section 4.0 in combination with Appendix C provides design recommendations for buildings and district energy which can be leveraged by developers. Section 5.0 provides economic assumptions and results, which can be used as a starting point for further analysis and provide benchmarks for comparison. Appendix F includes details of the estimated thermal loads over the course of the development which will be required by DES developers to estimate project costs and LCOE.



Appendix A CONCEPT BENCHMARKS

The following section provides a summary of existing high-performance building and district energy system options that have already been implemented in Canada and around the world and can provide useful insights into the options for LeBreton Flats (LBF). The section concludes with a summary of the feedback received from stakeholders on the preferred design concepts for LBF.

Building Benchmarks

Stantec Tower, Edmonton, Alberta⁴³

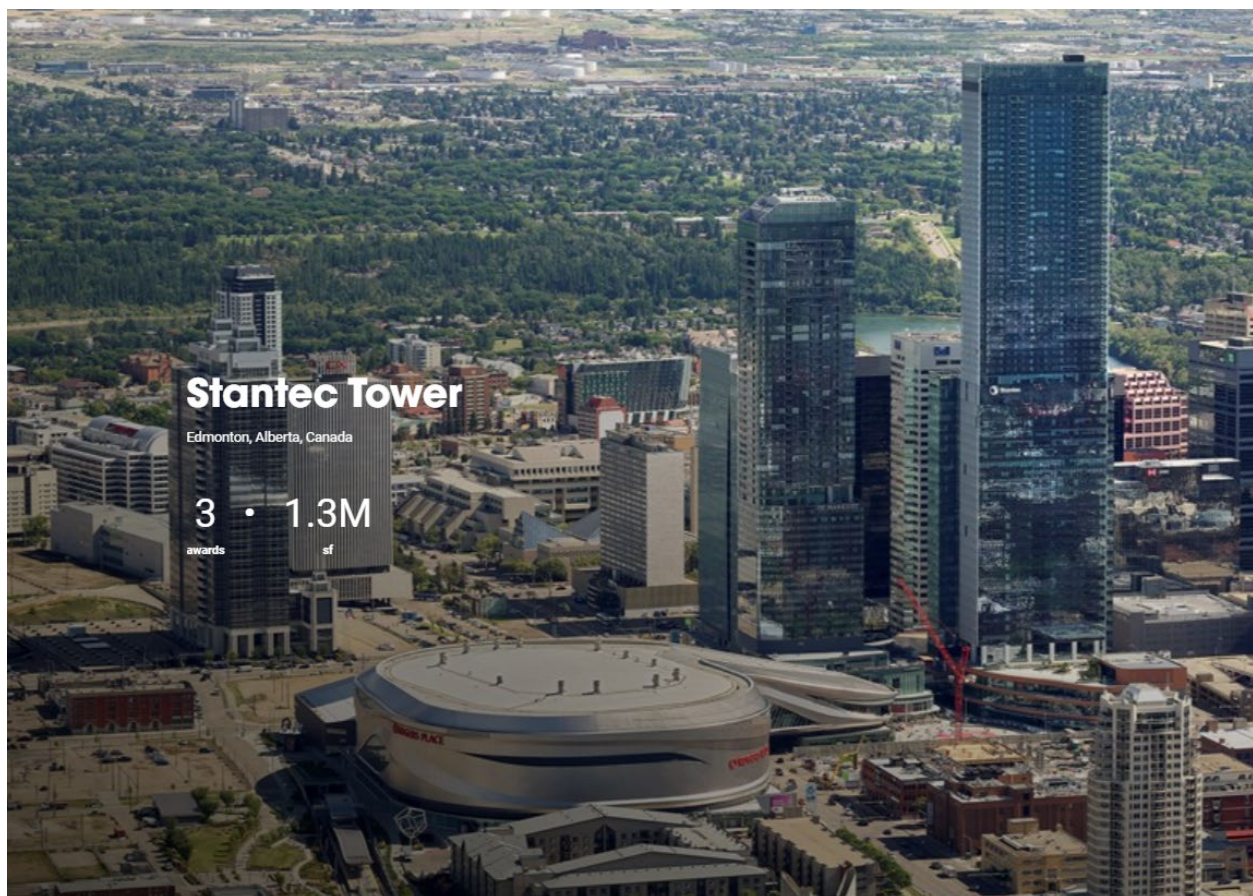

The project is summarized as follows:

- 381.3 million square feet of office space
- LEED Gold New Construction

⁴³ <https://www.stantec.com/en/projects/canada-projects/s/stantec-tower-edmonton>



LEBRETON FLATS ZERO CARBON COMMUNITY ENERGY PLAN

Concept Benchmarks

- Fitwel 2 Stars
- Exhaust air heat recovery
- Dedicated outdoor air systems using fan coil units and chilled beams
- Demand controlled ventilation (DCV)

Brock Commons Tallwood, Vancouver, British Columbia^{44,45}



The project is summarized as follows:

- LEED Gold New Construction
- 42% less energy consumption than reference building
- 52% less indoor and 66% less outdoor potable water use compared to a reference building
- 19% recycled content by materials value

⁴⁴ <https://sabmagazine.com/residential-large-award-winner/>

⁴⁵ <https://energy.ubc.ca/ubcs-utility-infrastructure/district-energy-hot-water/>



LEBRETON FLATS ZERO CARBON COMMUNITY ENERGY PLAN

Concept Benchmarks

- 38% local materials content
- 76% reduction in construction waste compared to traditional practices
- Cross laminated timber (CLT) structure
- Exhaust air heat recovery for ventilation
- Electric baseboards
- Split DX cooling
- Connection to UBC's hot water district energy system



Orion MURB, Pemberton, BC⁴⁶



**ORION:
A NEAR-ZERO EMISSIONS
MULTI-UNIT RESIDENTIAL BUILDING
IN PEMBERTON, B.C.**

CASE STUDY

Orion is a multi-unit residential building in Pemberton, British Columbia. The project is expected to exceed the energy efficiency requirements set for its region and meet Step 4, the highest level of the BC Energy Step Code, while maintaining the construction cost below the market rate. This case study presents practical solutions and strategies implemented during design and construction to deliver an affordable, sustainable, low-carbon, healthy building in British Columbia's South Coast.

October 2020

⁴⁶ https://zebx.org/wp-content/uploads/2020/10/ZEBx-Case-Study_Orion_2020-1.pdf



QUICK SUMMARY

INCREASED INSULATION
The exterior walls achieved an estimated overall performance of R48 using two layers of R24 insulation, batt insulation in the 2x6 walls and R24 as part of the EIFS wall system. The attic has R80 urethane foam insulation - **page 06**

INSULATED CONCRETE FORMS
in the foundation resist heat flow and moisture intrusion and contribute to the building's energy efficiency and occupants' comfort - **page 07**

THERMAL BRIDGING
is minimized by using a high-performance composite cladding system without mechanical fasteners and cantilevered glulam beams to support the balcony decks - **page 06**

LOWER PROJECT COST
by 12-34% than a similar residential building built to Step 1 of the BC Energy Step Code, due to implementing simple and cost-effective solutions that are streamlined on multiple similar projects by the same project team - **page 04**

EFFICIENT FENESTRATION
argon-filled, triple-glazed, low-E coated, Passive House certified windows provide efficient thermal performance and have a low solar heat gain coefficient to reduce the risk of overheating - **page 06**

MINIMAL HEATING
is provided by an integrated centralized system using air source heat pumps with variable refrigerant flow (VRF). The heating is distributed through the heat recovery ventilator for efficient space heating - **page 08**

ENERGY RECOVERY VENTILATORS
with an efficiency of 86% conserve energy by transferring heat from indoor air to preheat continuous incoming fresh air. There is a separate HRV system for the underground parkade - **page 08**

HEAT PUMP DOMESTIC HOT WATER
Single-pass heat pumps with CO₂ refrigerant increase the efficiency of the DHW system and reduce carbon emissions - **page 09**

EFFICIENT LIGHTING
is provided by LED light bulbs which are energy efficient and long-lasting and have motion sensors - **page 08**

EFFICIENT APPLIANCES
such as ductless condensing dryers reduce energy use and avoid airtightness and insulation penetrations - **page 08**



LEBRETON FLATS ZERO CARBON COMMUNITY ENERGY PLAN

Concept Benchmarks

Scotia Plaza's 40 King St. W., Toronto, Ontario⁴⁷



The project is summarized as follows.

- The first building certified under the Zero Carbon Building – Performance version 2 certification
- Heat recovery chillers
- Electric boilers

⁴⁷ <https://scotiaplaza.com/sustainability.html>



LEBRETON FLATS ZERO CARBON COMMUNITY ENERGY PLAN

Concept Benchmarks

evolv1, Waterloo, Ontario⁴⁸



The project is summarized as follows:

- LEED Platinum New Construction
- Zero Carbon Building version 1 Design and Performance
- High performance envelope
- Minimized thermal bridging
- Triple glazing
- Exhaust air heat recovery
- VRF heat pumps

⁴⁸ https://www.cagbc.org/CAGBC/Zero_Carbon/Project_Profiles/evolv1_Profile.aspx



LEBRETON FLATS ZERO CARBON COMMUNITY ENERGY PLAN

Concept Benchmarks

- Geo-exchange field
- Solar PV
- Solar wall heaters

District Energy Benchmarks

Marine Gateway District Energy⁴⁹

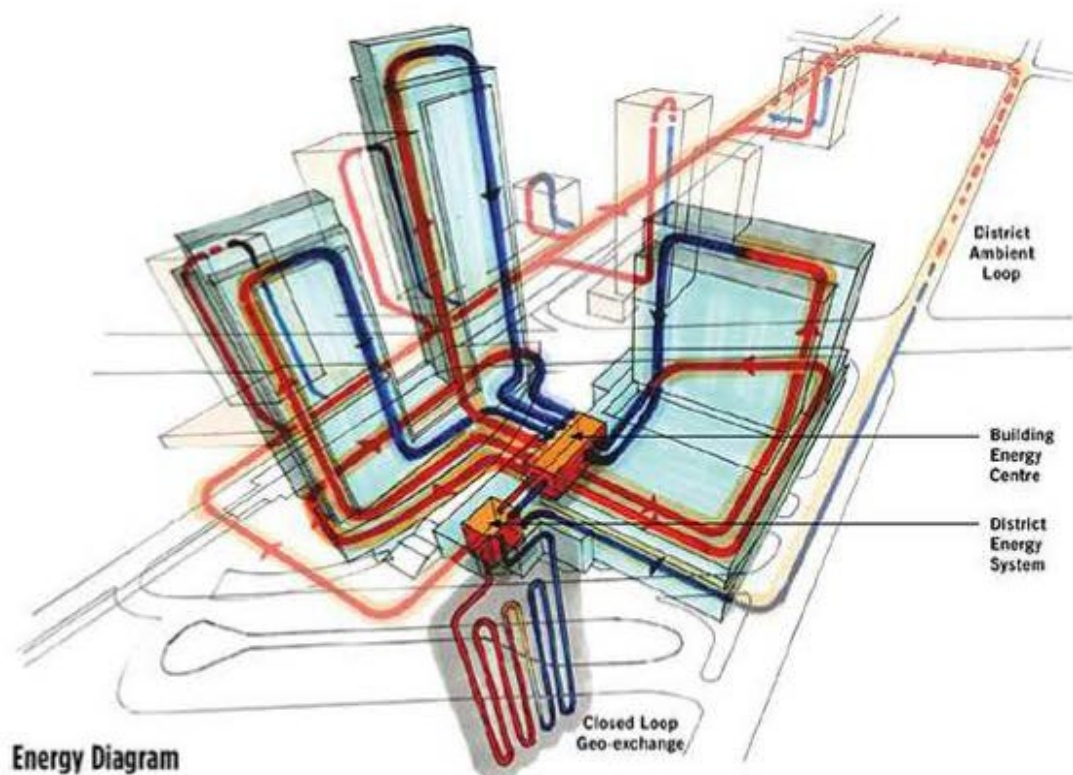

Image Source: SAB Magazine

The project is summarized as follows:

- Neighborhood scale district energy system
- Ambient temperature system to recover, store, and reuse waste heat
- Provides low carbon heating and cooling
- Technologies: geo-exchange field, heat pumps, grocery store refrigeration heat recovery, thermal energy storage

⁴⁹ Pinchin.



LEBRETON FLATS ZERO CARBON COMMUNITY ENERGY PLAN

Concept Benchmarks

WestJet Campus Headquarters

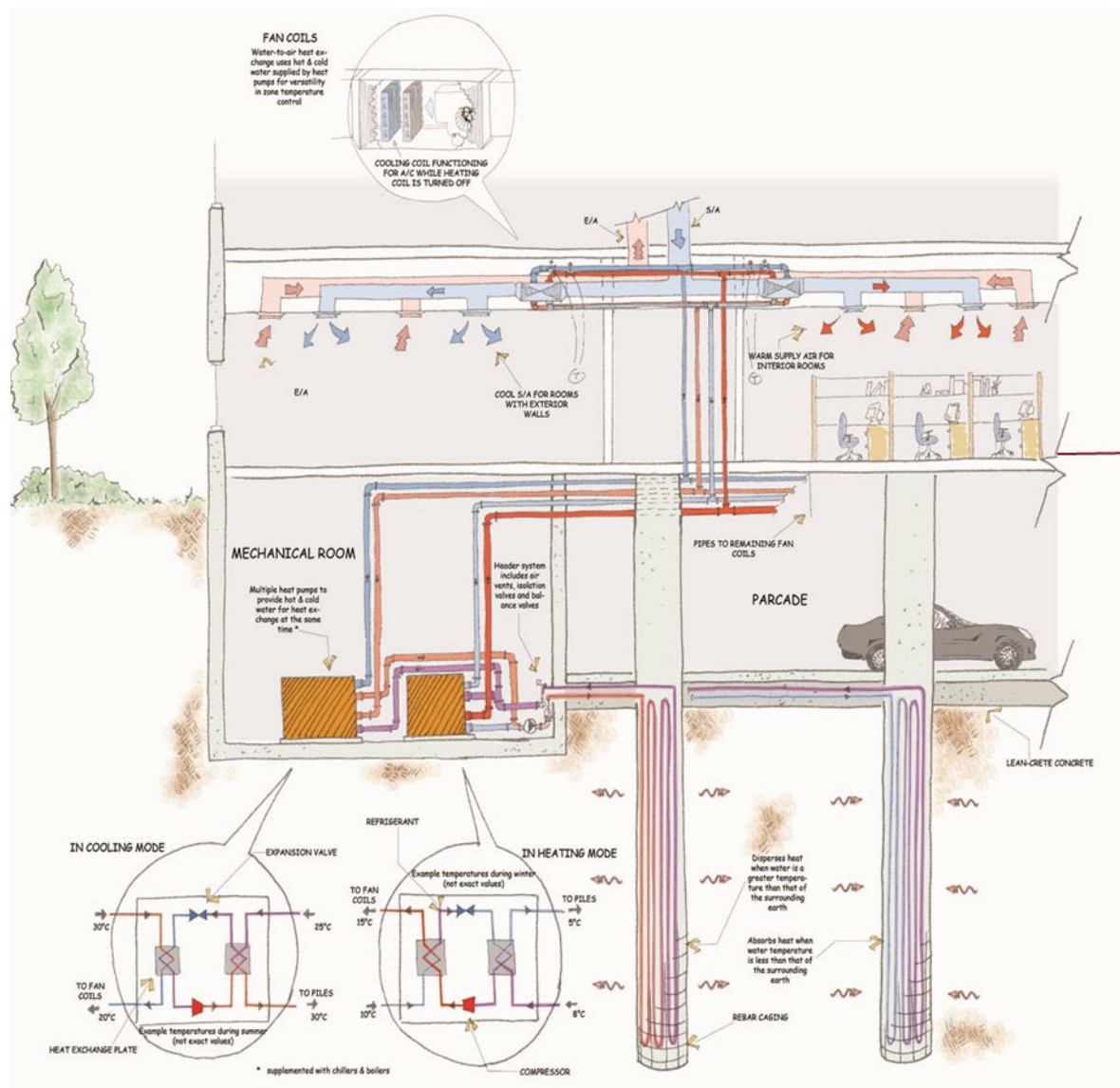

The project is summarized as follows:

- Geo-exchange loop using building foundations for energy transfer
- Heat pumps



LEBRETON FLATS ZERO CARBON COMMUNITY ENERGY PLAN

Concept Benchmarks

Zibi Waterfront Development⁵⁰



⁵⁰ Zibi.



LEBRETON FLATS ZERO CARBON COMMUNITY ENERGY PLAN

Concept Benchmarks

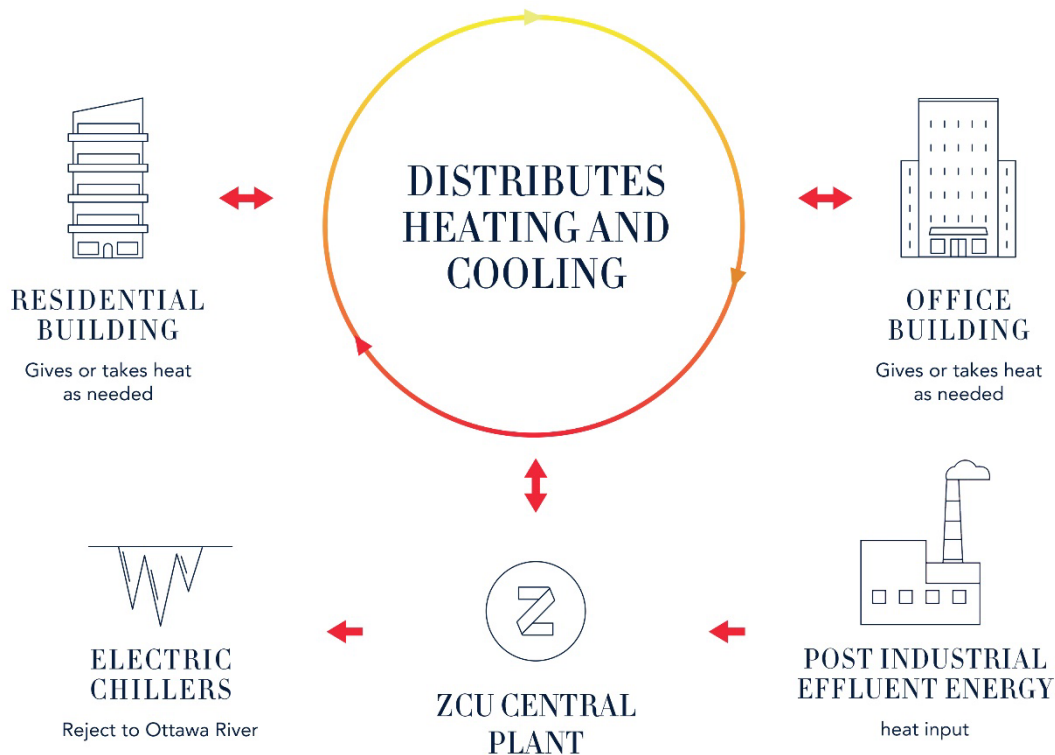

The project is summarized as follows:

- First in North America to use post-industrial waster heat recovery in a master planned community
- Planned to be the first carbon neutral community in the National Capital Region
- Uses energy recovery from local Kruger tissue plant waste heat for heating the community, and the Ottawa River for cooling



LEBRETON FLATS ZERO CARBON COMMUNITY ENERGY PLAN

Concept Benchmarks

CopenHill⁵¹



The project is summarized as follows:

- Cleanest waste to energy power plant in the world
- Exhaust air is clean and scrubbed of pollutants
- Energy centre is dual use, inviting the public to ski, climb, and visit the site
- Heating water and steam are generated in the process, steam is used for electricity generation

⁵¹ Dezeen.



LEBRETON FLATS ZERO CARBON COMMUNITY ENERGY PLAN

Concept Benchmarks

The Well Building Toronto⁵²

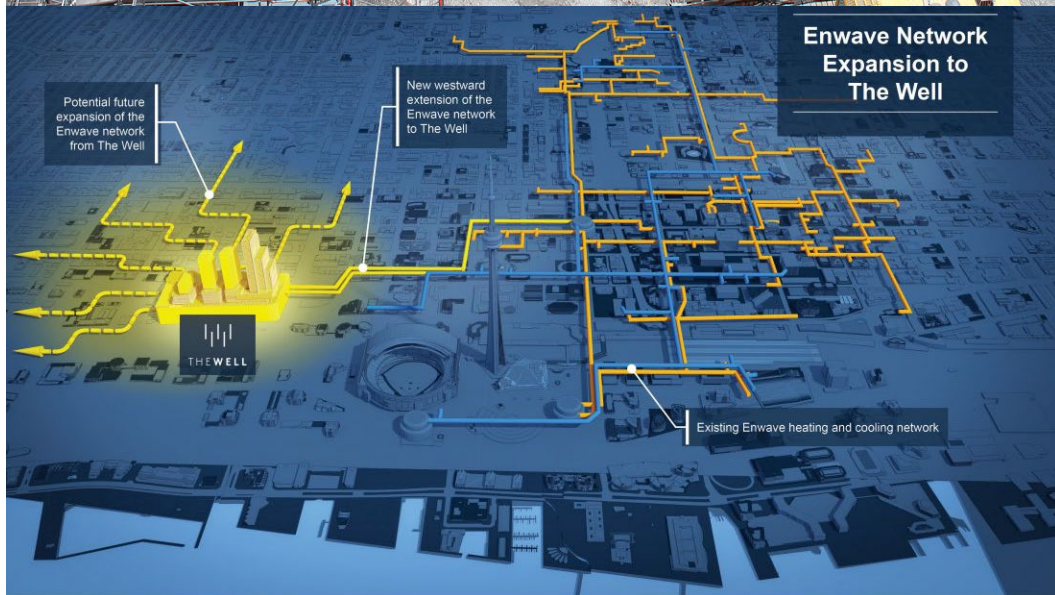

The project is summarized as follows:



LEBRETON FLATS ZERO CARBON COMMUNITY ENERGY PLAN

Concept Benchmarks

- Two, 6-million-litre tanks act as a thermal battery, storing energy at night during off peak times, easing the strain on the electricity grid and reducing costs.
- Adds resiliency to the existing Enwave district energy system.

District Energy St. Paul⁵³



The project is summarized as follows:

- 15-million-litre above ground storage tank incorporated into the existing district energy system.

⁵² <https://www.thewelltoronto.com/the-buildings/work/>

⁵³ BWBR.



LEBRETON FLATS ZERO CARBON COMMUNITY ENERGY PLAN

Concept Benchmarks

Bucknell University 1.6MW Solar Array⁵⁴



The project is summarized as follows:

- The array will be surrounded by an agricultural fence and will feature pollinator friendly vegetation between the panels.

⁵⁴ <https://encorerenewableenergy.com/bucknell-university-plans-1-6-mw-on-campus-solar-array/>



LEBRETON FLATS ZERO CARBON COMMUNITY ENERGY PLAN

Concept Benchmarks

Smart Flower Solar Array⁵⁵



The project is summarized as follows:

- Makes a statement about the use of renewable energy on the site.

⁵⁵ Smart Flower.



Appendix B STAKEHOLDER FEEDBACK

Workshop 1 – Achieving a Zero Carbon Community

Stakeholder Feedback

This section summarizes the feedback received from participants in the Community Energy Plan (CEP) Workshop #1 – Achieving a Zero Carbon Community.

- Participants agreed with the suggestion to use the City of Ottawa’s proposed High Performance Development Standard (HPDSs) as the benchmarks for Minimum Compliant Design and High-Performance Design. They also agreed with using CaGBC’s Zero Carbon Building (ZCB) standard for the Zero Carbon benchmark.
- Minimizing operational carbon at the building level through energy efficiency and fuel switching were identified as high priorities. It was noted that decarbonizing the DES could prove more challenging if on-site combustion is required.
- Embodied carbon was recognized as being important to the lifecycle carbon analysis but should be treated as an add on in this study since the field is very nascent and offsets will be required to achieve zero carbon.
- Due to land constraints at LBF, off-site renewable energy generation on other NCC land should be prioritized. Generation on NCC land should be prioritized over the purchase of renewable energy certificates (RECs).
- Carbon offsets should be minimized as it can be challenging to determine what is an effective offset.
- Emergency backup generation beyond typical code requirements was not identified as a priority, so the analysis will not include this.
- Transportation was not identified as a core component, but simple mechanisms such as building EV ready should be included.
- The CaGBC ZCB standard of 60 years to achieve net-zero carbon was considered appropriate but with an emphasis on accomplishing as much as possible upfront, i.e., a zero-carbon ready design, with the recognition that decarbonizing fuels such as electricity will take longer.



LEBRETON FLATS ZERO CARBON COMMUNITY ENERGY PLAN

Stakeholder Feedback

SWOT Analysis

Strengths	Weaknesses
Consideration	Consideration
Greater protection against rising utility costs	Construction industry may not have the right skills to build this
Greater protection against extreme weather events	Electricity prices are too high to electrify natural gas end uses
More livable floorspace as occupant comfort is improved near walls and windows	Changing architectural components such as window to wall ratio could compromise the view and saleability
DES will allow for much smaller mechanical rooms and less equipment, as well as less complicated equipment (e.g., heat exchangers vs. boilers)	Advanced mechanical systems require specialised O&M and existing staff cannot handle them
Higher quality design means less issues during construction – cost savings for developer, faster construction times, quicker occupancy	Systems and designs are unfamiliar to the builder and mean increased risk compared to business as usual
Potential for significant return on investment, especially purpose-built rentals (due to ability to benefit from lower utility costs)	
Opportunities	Threats
Consideration	Consideration
There are many reputable companies that can build to these standards today	Electricity grid is already considered clean enough, why pursue renewable generation?
Grants and other supports for high performance development (governments, utilities, etc.)	Perception that renewable energy generation is not cost effective and difficult/expensive to maintain
This housing is more desirable as a long-term investment, attracting more and wealthier buyers	The argument that the market should dictate this, not regulations
Resale values are higher	Other developments that are not held to these standards will have an advantage
LBF is prime location, property values will be higher regardless	Construction time could be longer
Ottawa needs to be a leader in sustainability	Customers want to have natural gas for cooking, especially commercial kitchens
Developer can use social responsibility as a marketing angle	Climate change denial
Developer has an opportunity to be ahead of the pack as improvements become code minimum	Failure to capitalise on the benefits through increased sale price
The demographic near LBF is wealthier and more educated than average and are willing to spend more money to lead a more sustainable lifestyle. This raises the selling price for housing of this type	Shortage of tradespeople with sustainable building experience
	Shortage of materials, longer supply chains
	Budget constraints – higher upfront capital cost, even if investment is recouped later
	Gross margin could be lower compared to current standards
	Builders may not be able to recover additional capital costs through higher sales prices if buyers do not want the improvements
	Pushback on standards that exceed the City minimum
	Failure to appreciate the benefits



LEBRETON FLATS ZERO CARBON COMMUNITY ENERGY PLAN

Stakeholder Feedback

Workshop 2 – Achieving a Zero Carbon Community: Building Performance

SWOT Analysis

Strengths	A	B	C	Weaknesses	A	B	C
Consideration				Consideration			
Envelope is minimum, easy and cheap to achieve	✓			Envelope upgrades are challenging post construction	✓		
Improved resiliency		✓	✓	Increased embodied carbon in better components (trade off vs. operational)		✓	✓
High performance appliances (occupant comfort, etc.)		✓	✓	Thicker wall, reduced floor area		✓	✓
Simpler building systems	✓			Heavier windows		✓	✓
DES - helps developer with first costs and sales costs	✓	✓	✓	Future liability if you do not achieve ZC – future retrofits (developer needs to avoid “stranded assets”)	✓	✓	
Change in performance standard is protected against			✓				
Performance based, multiple pathways to achieve results		✓	✓				
Architectural elements are not constrained	✓	✓	✓				
Utility rate escalation mitigated		✓	✓				
Leadership and innovation		✓	✓				
Future liability if you do not achieve ZC – future retrofits (developer needs to avoid “stranded assets”)			✓				
Switchover from heat to cool (2-pipe) – occupant comfort		✓	✓				
Reducing cost of DES (smaller loads)		✓	✓				
Opportunities	A	B	C	Threats	A	B	C
Consideration				Consideration			
Can further improve resiliency through envelope improvements	✓			Change in performance standard could mean target is missed	✓	✓	
High performance appliances (occupant comfort, etc.) – selling feature		✓	✓	Must meet prescriptive requirements, easier to miss	✓		
Encourage rentals (address principal/agent barrier) – single owner buildings	✓	✓	✓	Price of carbon offsets escalating	✓	✓	✓
Affordability, energy poverty (lower energy bills)		✓	✓	Principal/agent barrier	✓		
Easy to convert building from own to rent – increased flexibility, design decisions			✓	Need clever integration of buildings and DES (building vs. community)			✓
Renting – invest in more durable materials (lifecycle carbon)		✓	✓	Predicting DES load on DES is challenging			✓
Further opportunities for reduction through WWR	✓	✓	✓	Low flow fixtures are difficult – shower is “sacred”		✓	✓
Should consider mandating better TEDI performance	✓	✓		Low infiltration rate is difficult to achieve		✓	✓
Innovation opportunity – thermal storage			✓	Impacts to retail – need for gas for cooking, RNG, etc.			✓
DER – LBF as asset rather than burden			✓				
30 yr timeframe – can pass on lessons learned		✓	✓				
Improved O&M strategies	✓	✓	✓				
Incorporate smart home controls		✓	✓				
Reduce peak demand loads and cost		✓	✓				
Onsite electrical storage		✓	✓				
Remove balconies on upper floors – or completely thermally isolated		✓	✓				



Appendix C ADDITIONAL LOW CARBON MEASURES

HVAC – Air Side

Right-Sized VAV AHUs with Heat Recovery

A conventional variable air volume system (VAV) comprises of a recirculating central air handling unit and VAV boxes located in the spaces or zones. The system works by regulating the volume of the air to the space being fed using a damper in the VAV box.

Modern right-sized air handling systems can be designed to meet the space conditioning loads and provide comfort at a supply airflow of around 2.8 L/s-m² (0.55 CFM/ft²) using a conventional VAV system. This measure relies on accurate determination of the overall heating and cooling loads of the spaces, taking into consideration envelope measures.

Heat Recovery: Air-to-air energy recovery is the process of recovering heat from one air stream and transferring it to another air stream. In most applications the process entails recovery of heat from building exhaust air to preheat outside air used for ventilation. It is an important design consideration of ventilation systems to limit energy consumption and operation costs in buildings that require large volumes of outside air.

Heat recovery technology includes plate heat exchangers, heat wheels, heat pipes, and runaround loops. Each one offers a different level of performance or heat recovery effectiveness that normally range from 35% effectiveness for runaround loops to 75% for heat wheels.

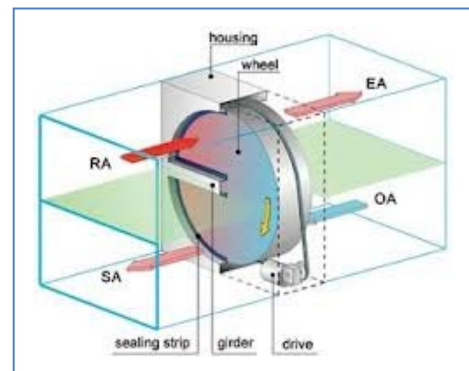

Figure: Air-to-Air Heat Recovery

Source: <https://www.researchgate.net/>

High-efficiency energy recovery ventilators (ERVs) can reach sensible effectiveness of 85% and higher. Sensible and latent heat can be recovered depending on the type of technology. Plate type, heat pipes, and runaround loops can only recover sensible heat while heat wheels can recover both sensible and latent.

Advantages

- Significant energy savings.
- Reduced operational and maintenance cost savings.
- Designers in North America are more familiar with the VAV design.

Disadvantages

- Does not offer the same level of energy savings as other HVAC technologies with a DOAS and terminal unit system.



Chilled Beams with DOAS and Heat Recovery

An important design consideration with respect to achieving effective ventilation with a central HVAC system, such as a multizone VAV system, is that the sensible loads do not necessarily have a linear correlation with ventilation requirements on a zone-by-zone basis. In other words, a limitation of central VAV systems is that a system-wide rise in outdoor air (OA) can be triggered by increased ventilation requirements in certain critical zones that require additional OA to comply with ASHRAE 62.1. However, other zones served by the central system may have stable sensible loads and ventilation requirements and this can result in overventilation of several spaces. This results in significant net energy consumption due to the requirement of conditioning the additional outside air.

The complementary pairing of a dedicated outside air system (DOAS) and chilled beams an alternative technology to conventional all-air ventilation systems such as the VAV mixed air systems.

While VAV and CAV systems are typically sized to meet the entire space cooling load with central AHUs, DOAS and chilled beams decouple the sensible and latent space loads such that chilled beams address the space sensible loads while the DOAS mitigates the sensible and latent loads for the outside air only. To induce room airflow, active chilled beams need slightly more supply air than supplied by the DOAS, which typically supplies only the minimum ventilation air required to meet ASHRAE 62.1 requirements. This may necessitate a slightly larger DOAS.

The advantage of this design over traditional all air systems is the potential for significant fan energy savings which is typically a large end use for most buildings. This is accomplished with the understanding that the DOAS fan is only sized to supply the volume of OA necessary to meet indoor air quality (IAQ) requirements and there is only a small amount of additional fan power required for the active chilled beams. This results in a fan power reduction of approximately 65%, as outlined in the following table.

This HVAC solution would be more applicable to the commercial spaces with low latent load.

Heat Recovery: Air-to-air energy recovery is the process of recovering heat from one air stream and transferring it to another air stream. In most applicable the process entails recovery of heat from building exhaust air to preheat outside air. It is an important design consideration of ventilation systems to limit energy consumption and operation costs in buildings that require large volumes of outside air.

Heat recovery technology includes plate heat exchangers, heat wheels, heat pipes, and runaround loops. Each one offers a different level of performance or heat recovery effectiveness that normally range from 35% effectiveness for runaround loops to 75% for heat wheels.

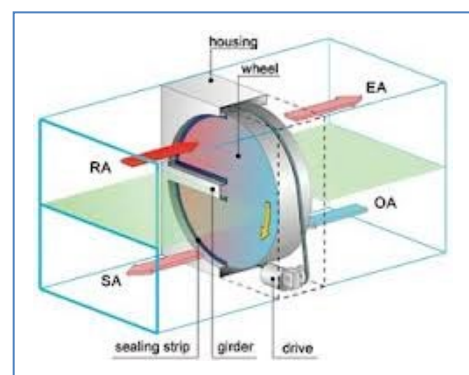

Figure: Air-to-Air Heat Recovery

Source: <https://www.researchgate.net/>



LEBRETON FLATS ZERO CARBON COMMUNITY ENERGY PLAN

Additional Low Carbon Measures

High efficiency energy recovery ventilators (ERVs) can reach sensible effectiveness of 85% and higher. Sensible and latent heat can be recovered depending on the type of technology. Plate type, heat pipes, and runaround loops can only recover sensible heat while heat wheels can recover both sensible and latent.

Advantages

- Provides superior occupant thermal comfort compared to conventional systems by controlling both indoor air temperature and mean radiant temperature of the radiant panel system.
- The higher cooling temperatures used with radiant panel systems provide many opportunities for reducing energy use by incorporating water-side economizer systems.
- Radiant cooling and heating systems, particularly when bundled with other technologies have the highest technical energy savings potential in terms of simple payback period.
- Radiant systems reduce mechanical footprint and air riser space and increase the amount of floor space available for use. In-floor radiant systems simplify wall, floor, and structural systems. Exposed space-conditioning equipment is small or not required.
- Potentially lower maintenance costs compared to a VAV design with VAV boxes.

Disadvantages

- Lack of industry familiarity with the technology in North America (chilled beams).
- Is not ideal for residential spaces usually due to piping penetrating into the residential units.
- No air side economizer, requiring year-round chilled water which increases the complexity of the cooling plant design and controls.

Displacement Ventilation

Displacement ventilation (DV) is an alternative to the conventional mixed flow overhead ventilation systems such that conditioned OA is supplied at low velocities from diffusers located near floor level and returned or exhausted above the breathing zone, typically close to ceiling height. This system has the potential to yield significant fan and cooling energy savings, as well as providing improved IAQ. It is generally suited to spaces with high ceilings above 3m (10ft).

DV is not to be confused with the similar technology of underfloor air distribution systems since DV systems are designed at both lower total air flows and lower air velocities, typically in the range of 1 to 1.5 m/s (20 to 30 FPM). Due to the low airflows, which will typically range from 1.0 to 2.5 L/s·m² (0.2 to 0.5 CFM/ft²), DV systems typically need to be used in conjunction with radiant chilled ceilings that operate as a heat sink to mitigate thermal stratification issues that these systems commonly face when improperly designed.

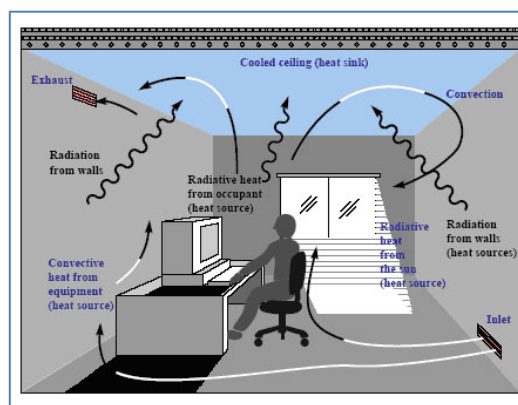

Figure: Displacement Ventilation

Source: [http://renopedia.wikia.com/wiki/Radiant Cooling](http://renopedia.wikia.com/wiki/Radiant_Cooling)



LEBRETON FLATS ZERO CARBON COMMUNITY ENERGY PLAN

Additional Low Carbon Measures

The low air velocities of DV systems typically achieve natural convective air plumes that leads to higher occupant satisfaction due to the effectiveness of exhausting contaminated air from the breathing zone. Displacement outlets are generally located at or near floor level. Air is supplied at the lower level with an outlet air velocity of 2 m/s (40 FPM) and a supply air temperature (SAT) of 17 to 20°C (63 – 68 °F) to avoid cold sensation of occupant's feet.

Advantages

- Low air velocities at diffusers results in less noise.
- Low air velocities at diffusers leads to lower system pressure drops (smaller horsepower fans).
- Increased IAQ due to more effective removal of contaminants.

Disadvantages

- Occupants may experience a thermal gradient due to differences in temperature between feet and head.
- Potential drafts near diffusers.

VRF Heat Recovery (VRF-HR) Systems Coupled with District Energy System

Variable Refrigerant Flow (VRF) systems are ductless commercial HVAC systems consisting of an outdoor condensing unit and several indoor evaporator cassettes. These systems are equipped with a compressor that can vary the refrigerant flow based on space conditioning demands at the terminal level. The technology is similar to “*mini-split systems*” with up to sixteen (16) individual indoor evaporators served by a single outdoor condensing unit, although they have recently become available in ducted configurations. They can also be thought of as an alternative to a DOAS system with fan coils (DOAS+FC), where the indoor evaporators replace the fan coils. VRF with heat recovery can also provide simultaneous heating and cooling, similar to a WLHP system, by transferring rejected heat to spaces with heating loads.

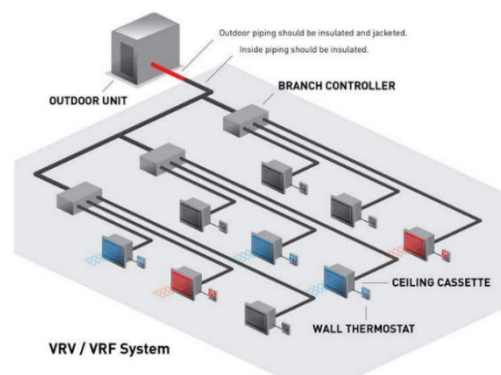

Figure: VRF-HR System

Source:
<https://mepwork.blogspot.com/2017/08/comparison-between-vrf-and-vrv.html>



LEBRETON FLATS ZERO CARBON COMMUNITY ENERGY PLAN

Additional Low Carbon Measures

VRF technology has gained popularity in North America as it is an energy efficient alternative to traditional rooftop units, while only exhibiting a modestly higher first cost. It is typically installed in smaller commercial and residential buildings and there are several advantages, in addition to energy efficiency, such as additional ceiling space gained from reducing the size of ventilation ductwork due to the high energy capacity of refrigerant piping. Some building owners may be apprehensive to install refrigerant piping within occupied spaces but should rest assured that stringent design standards (CSA B52-13) are followed and VRF systems in Ontario are generally inspected and registered with TSSA. In addition, refrigerants used in these systems are typically non-toxic. Energy savings of 20% are possible with a VRF-HR based on literature and measured performance.

Connection to District Energy System: The VRF system can leverage the district energy loop planned for LBF to increase the overall efficiency of the systems. Using the constant temperature from the loop as a heat sink would raise the overall coefficient of performance (COP) of the systems to achieve further energy savings and carbon reductions.

Advantages

- High integrated energy efficiency ratio (IEER) resulting in energy savings and GHG emissions reductions.
- Increased occupant comfort due to terminal controllability.
- VRF-HR can operate as a heat pump and achieve space heating energy savings.
- Offers significant fan energy savings compared to a central all-air system and similar to the fan energy savings that can be achieved with a DOAS+FC.
- Variable speed compressors and fans allow precise capacity modulation.
- Eliminates need for hydronic cooling systems and associated O&M costs.
- Recovers space within ceiling plenums for other services.
- Can use the district energy loop to increase the VRF system's coefficient of performance.

Disadvantages

- Potential for refrigerant leaks in the building; can potentially cause asphyxiation if not designed to code but this is unlikely with current codes and design practices.
- Limited airside free cooling capability.
- Potentially higher maintenance costs to repair the individual evaporators and fan motors.
- Technology is generally limited to medium sized buildings due to a 300 metres maximum equivalent length of refrigerant piping and stricter vertical length requirements.
- VRF systems rely on long runs of refrigerant piping, which requires specialized design knowledge.
- Leakages in the refrigerant system would require carbon offsets to maintain the carbon zero target of the community. Alternatively, newer, lower GWP refrigerants should be considered when selecting equipment.



Central Water-Source Heat Pumps coupled with District Energy System

Technology Description

Central heat pumps provide heat for space heating and are also known as central water to water heat pump systems. The typical application consists of a large heat pump that operates similar to a chiller with a condenser that is split in two. Conventional heat recovery chillers, during the summer months, operate in the conventional mode with the condenser heat rejected to a cooling tower. In winter, the condenser rejects heat to the heating loop while the evaporator provides cooling to interior spaces. For dedicated central heat pumps, the operating and control parameters are tightened (e.g., lower load variation) but greater performance can be achieved.

Double bundle centrifugal chillers are the most popular configuration. In the last 10 to 15 years, manufacturers introduced smaller, modular scroll compressors in reduced capacities that can be grouped together. Although the technology can achieve high COPs (~4.0), the chillers can typically only produce hot water at a maximum temperature of ~45°C (~113°F), limiting their ability to meet the heating load during the entire heating season. However, newer modular scroll chillers can achieve higher compressor lift and be specified to supply heating water around ±60°C (140°F), at the expense of a lower heating COP that would typically be in the range of 2.5 to 2.8. The combined COP of producing chilled water, when combined with the heating COP, can achieve nearly unparalleled cost effectiveness and reduced GHG emissions when applied in its ideal design configuration in comparison to conventional natural gas boilers and electric chillers.

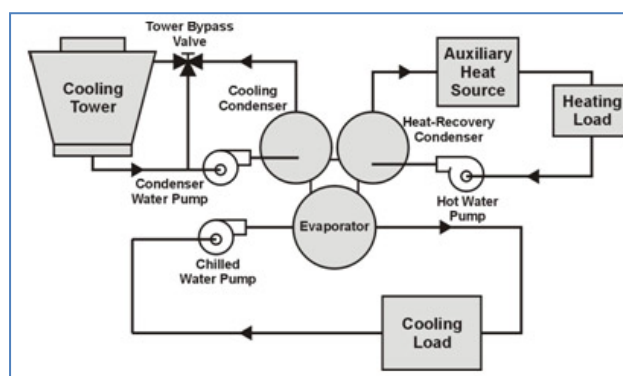

Figure: Heat Recovery Chiller

Source: ee.emsd.gov.hk/english/air/air_technology/air_tech_water.html#5

Nevertheless, load variation is a significant limitation of central heat pumps and heat recovery chillers in that it can be challenging to control the temperatures of the chilled water on the evaporator side. Accordingly, this technology is generally only suitable for buildings with significant and stable cooling loads during winter months such as data centers or buildings that have access to a heat source, such as a large body of water, an underground geo-exchange wellfield or a district energy loop in which the operator allows it.

LEBRETON FLATS ZERO CARBON COMMUNITY ENERGY PLAN

Additional Low Carbon Measures

Distributed heat pumps can also be referred as water loop heat pumps (WLHPs). These distributed, small tonnage heat pumps are capable of transferring heat from one space to another using multiple water-to-air heat pump units in buildings that require simultaneous heating and cooling (e.g., office buildings in the winter with core and perimeter loads or MURBs in the shoulder seasons when South facing units require cooling while North facing units require heating).

Units are connected via a hydronic connection using a common two-pipe loop. Heat pumps in cooling mode, serving an interior zone, will cool the air and reject the heat to the loop. This heat is then available to the heat pumps operating in heating mode serving a perimeter zone. A properly balanced design, where half of the of the heat pumps operate in heating mode and half in cooling mode, would display high heating and cooling coefficient of performance (COPs) as high as 3.5. The design includes a central boiler and cooling tower for times when all or most of the heat pumps would be in heating mode or cooling mode.

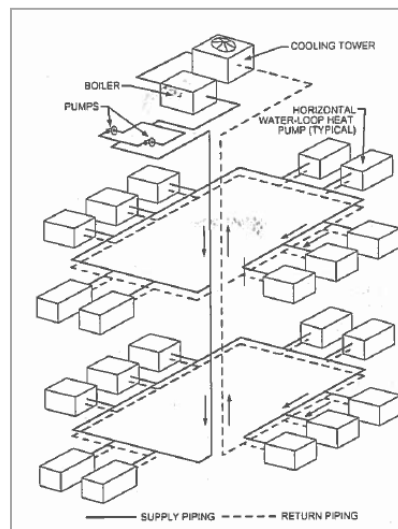

Figure: Distributed Heat Pumps

Source: 2016 ASHRAE Handbook – HVAC Systems & Equipment, Chapter 9

Connection to District Energy System: Central heat pumps and distributed heat pumps can leverage the district energy loop planned for LBF to increase the overall efficiency of the systems. Using the constant temperature from the loop as a heat sink would raise the overall coefficient of performance (COP) of the systems to achieve further energy savings and carbon reductions.

Advantages

- Theoretical lower energy and GHG emissions when applied properly.
- A highly efficient system that produces both heating water and chilled water.
- Can use the district energy loop to increase the heat pump system's COP.

Disadvantages

- Historically, double bundle chillers have had mixed results in terms of performance because of the low hot water temperatures that they produce, which are below the temperatures that buildings typically require.
- WLHP systems have also historically had mixed results in terms of performance matching design intent. Heating COPs are typically much lower because boilers inject more heat into the loop than what would be expected. This occurs in projects where the balance of heating and cooling loops is not ideal (e.g., too many zones needing heating and too few zones requiring cooling).
- Major variations in heating and cooling load can create performance issues.



LEBRETON FLATS ZERO CARBON COMMUNITY ENERGY PLAN

Additional Low Carbon Measures

- Difficult to control as the hot water loop temperatures need to be matched to the hot water temperatures that can be produced by the heat recovery chillers. For distributed WLHP, the hydronic loop needs to be designed to ensure that heat rejection and up-take is balanced.
- Higher maintenance costs due to multiple compressors and filters in WLHPs.
- Higher breakdown maintenance costs than similar terminal units (e.g., fan coils and chilled beams) due to failed compressors in WLHPs.

Mixed-Mode Ventilation

Mixed-mode ventilation systems are systems that primarily rely on natural ventilation provide adequate ventilation, with assistance by fans only as needed. Natural ventilation makes use of outdoor air brought into the building by wind or natural convection through operable windows.

Critical requirements of mixed-mode designs include a high-performance building envelope, large thermal mass, and effective shading strategies to ensure minimal need of heating and cooling.

Mixed ventilation designs typically include multiple design elements such as:

- Operable windows or ventilation grilles that are usually automatically controlled.
- Automatically controlled shading devices.
- Solar chimneys or atria, often with backup fans.
- Efficient fan systems for the back-up fan system to minimize fan energy use.



Figure: Mixed-Mode Ventilation

Source:
<https://www.constructioncanada.net/atriums-ideal-for-dual-purpose-natural-ventilation-systems>

Advantages

- Well-designed mixed-mode systems tend to include significant passive design features, which are aligned with significant improvement in occupant comfort and occupant satisfaction.

Disadvantages

- Difficult to design and implement.
- Difficult to control IAQ.
- Can only be applied to a limited number of mild Climate Zones.
- Operable windows have a lower thermal performance than fixed windows.



LEBRETON FLATS ZERO CARBON COMMUNITY ENERGY PLAN

Additional Low Carbon Measures

IAQ Procedure for Outdoor Air Reduction

The most prevalent design and operational practice for providing ventilation air to buildings involves replacing the entire volume of air within buildings up to 20 times per day (0.83 ACH), depending on space usage. This practice has long been the industry accepted method to maintain occupant comfort and indoor air quality (IAQ) as per the prescriptive ventilation rate procedure (VRP) of ASHRAE 62.1. However, this process of maintaining IAQ in this climatic zone requires significant energy input to condition outdoor air due to the drastic temperature extremes that are observed in both summer and winter. Accordingly, any significant reduction in OA requirements translates to substantial savings in terms of energy use, operational costs, and GHG emissions.

This technology involves the use of mechanical equipment to monitor, capture, and purge molecular air contaminants including carbon dioxide (CO₂), volatile organic compounds (VOCs) and formaldehyde (HCHO) from the return airstream. In doing so, it becomes possible to follow the performance-based Indoor Air Quality Procedure (IAQP) outlined in ASHRAE 62.1 which, for the vast majority of buildings, lowers the OA intake rates for buildings. The IAQP stipulates the design basis for analyzing the contaminant sources, concentration limits and level of perceived indoor air acceptability in order to set the amount of OA required.

Once designed and commissioned as per the IAQP, the packaged mechanical equipment at the root of this technology continuously monitors the return airstream for contaminants, captures contaminants, and manages the OA intake for its associated air handling unit (AHU). When the building is detected to be at non-peak occupancy, the self-cleaning equipment purges the contaminants about once per day.

This results in considerable net savings over the VRP as this method monitors and removes contaminants at the source instead of supplying and exhausting large volumes of air to dilute the air within conditioned spaces. However, it is worth noting that these systems are designed to be installed in the return airstream in conjunction with AHUs or ERVs; as a result, they are not designed for systems which do not have a return airstream such as DOAS or make-up air units.

Advantages

- Reduces overall size of HVAC equipment due to load reduction for conditioning outside air especially in Ottawa's climate zone.
- Significant reduction in operating costs due to HVAC load reduction and energy usage.
- Small footprint and relatively simple installation with low first cost.
- IAQP qualifies for LEED points and possibly utility rebates.

Disadvantages

- Not well suited for systems that use a DOAS (e.g., DOAS + fan coils).
- Requires additional engineering design knowledge and effort for IAQP over traditional VRP.



LEBRETON FLATS ZERO CARBON COMMUNITY ENERGY PLAN

Additional Low Carbon Measures

Renewables and Other Measures

PV Integrated Windows

Photovoltaic (PV) glass is a technology that enables the conversion of sunlight into electricity.

PV vision glass integrates a thin-film, semitransparent PV panel with an exterior glass panel in a traditional double-pane window. All the PV types can be integrated and/or laminated in glass, but only thin-film PVs will be translucent. Electric wires extend from the sides of each glass unit and are connected to wires from other windows, linking up the entire system. If the PV cells are part of the vision glass, various degrees of transparency are possible, as in frit glass, since the PV cells offer shade and produce electricity.

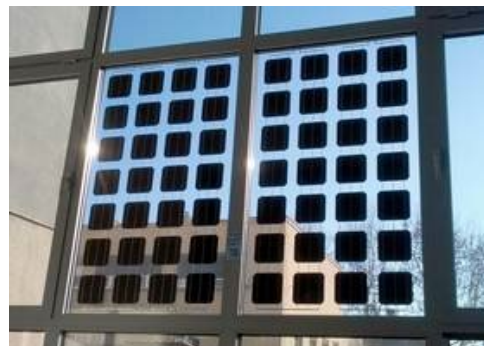

Figure: PV Integrated Windows

Source: [lpvo.fe.uni-lj.si/en/aplikacije/pv-okna/](http://pvo.fe.uni-lj.si/en/aplikacije/pv-okna/)

PV glass is available with a variety of aesthetic options including an assortment of colours, gradients, and patterns as well as double or triple-glazed products. Current PV production technologies, pricing structure, and energy rates limit BIPV use to prominent, prestige buildings (although PV-integrated cladding costs are comparable to marble). Of course, as these factors are in constant flux, BIPVs are receiving increased attention that is justified by the promise of a building envelope that can generate energy in addition to providing a thermal envelope.

Advantages

- PV glazing is customizable as the glazing units themselves can be purchased and integrated into custom frames.
- Clean energy, zero combustion, and no greenhouse gas emissions from use.
- Readily available commercial and customizable products.
- Do not require any additional site area.

Disadvantages

- Higher operational temperatures may be experienced with the lack of passive ventilation of the PVs.
- Requires energy storage or grid connection for continuous round-the-clock use.
- Decrease daylight transmission to the building interior.

Solar Preheat

The solar preheat system uses the solar energy to preheat the incoming outdoor air. This technology involves adding a heat absorbing medium that preheats incoming ventilation air, reducing the presently



LEBRETON FLATS ZERO CARBON COMMUNITY ENERGY PLAN

Additional Low Carbon Measures

high GHG-emitting heating energy required for tempering it. When the solar preheat is coupled with PVs, it serves the dual purpose of reducing the cell temperature of the PV panels which prolongs their expected useful service life.

Advantages

- Will reduce heating consumption and associated cost and GHG emissions through applying renewable technology.
- Reasonable initial capital cost for purpose-built renewable application.

Disadvantages

- Mutually exclusive with heat recovery systems which may offer better savings potential.
- This may not be the most effective use of limited roof space compared to solar PV panels.

Wind Turbines

Wind turbines are a sustainable source of energy that use wind power, a renewable energy source, to generate electricity. The power generated depends on the speed and direction of the wind which varies from location to location. Therefore, large wind turbines are equipped with motors that control the yaw and pitch of the blades. The size and profile of the blades are also factors that affect the amount of power generated.

Ideally, wind turbines are installed in large open spaces such as farms but can also be installed in urban areas on roofs or in parking lots. Although the wind turbines would not be operating at their maximum efficiency in these conditions, there remains a potential for significant savings.

Advantages

- A mature sustainable technology that guarantees energy savings.
- Shows commitment to generating clean energy.
- Emits no greenhouse gases or waste products.

Disadvantages

- Requires a significant amount of space.
- Requires maintenance resulting in some additional costs and periods of downtime.
- Not a constant source of power since it depends heavily on wind availability and speed.
- Very expensive to install.
- Lengthy permit and approval process (related to potential tenant complaints from noise, blade reflections, safety requirements, and the potential negative impact on habitat).

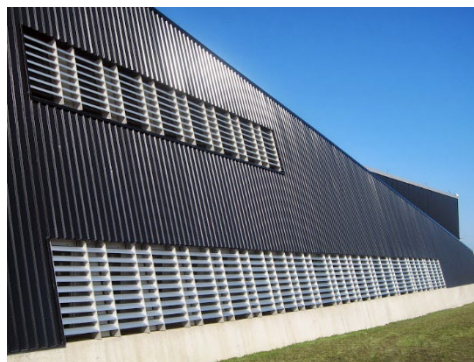

Figure: Solar Wall on Building façade

Source: <https://archello.com/product/solarwall-solar-air-heating-system>



LEBRETON FLATS ZERO CARBON COMMUNITY ENERGY PLAN

Additional Low Carbon Measures

Solar Hot Water Heating

Solar thermal hot water heating systems consist of solar collectors, energy storage tanks and pumps which allow for renewable generation of hot water.

In the winter and other times when collection rates are lower than DHW demand, supplemental heat sources are needed to meet the demand.

Solar thermal water heating systems come in various configurations. Most commonly used solar collectors consist of flat plate collectors and evacuated tube collectors. There are also more specialized concentrating collectors for high temperature applications.

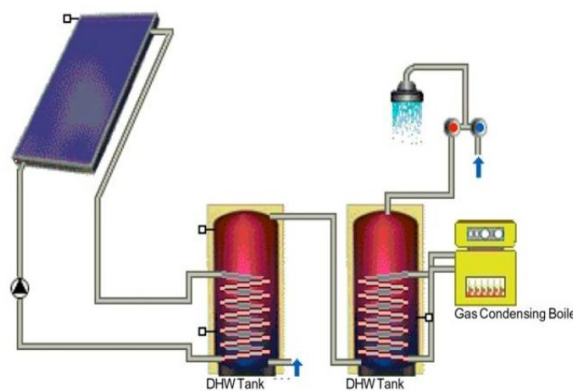

Figure: Solar Thermal System

Source: <http://www.williamsrenewables.co.uk/solar-thermal/system-designs/>

The technology is considered to be a mature technology and is well established in regions with high levels of solar radiation and expensive fuel sources. There are high quality flat plate and evacuated tube collectors from European and North American manufacturers that offer good performance and reliability.

Advantages

- Mature renewable technology.

Disadvantages

- The solar water heating system still requires a primary DHW system, so it represents a net additional cost.
- Additional maintenance costs for the collectors, pumps, and mixing valves.

Energy Storage

Energy storage is an emerging technology that favors utility rates based on time of use. Battery storage and/or flywheel technologies that are charged when electricity is cheaper (or available from intermittent renewable sources) and discharged when electricity is more expensive offer many benefits to owners who are looking to lower their utility costs, including the potential for peak load shaving.

Advantages

- Can be an enabling technology for on-site renewable energy generation.
- Can provide additional grid ancillary services such as voltage regulation.
- Can lower both consumption and demand charges.
- Fairly simple to install and operate.



LEBRETON FLATS ZERO CARBON COMMUNITY ENERGY PLAN

Additional Low Carbon Measures

Disadvantages

- High capital cost and depending on local utility rate structures could have long payback periods and poor financial performance.
- As a less mature technology, there is very little data available on equipment lifetimes and other O&M considerations.



Appendix D **GHG EMISSIONS FACTORS**



LEBRETON FLATS ZERO CARBON COMMUNITY ENERGY PLAN

GHG Emissions Factors

Year	IESO (gCO ₂ e/kWh)	OPG (gCO ₂ e/kWh)	TAF (gCO ₂ e/kWh)	PSPC (gCO ₂ e/kWh)	LBF (gCO ₂ e/kWh)	Gas (gCO ₂ e/kWh)
2015	N/A	N/A	N/A	96.0	N/A	177.3
2016	N/A	46.5	N/A	40.0	N/A	177.3
2017	N/A	50.2	N/A	36.0	N/A	177.3
2018	N/A	55.6	N/A	68.0	N/A	177.3
2019	N/A	62.7	34.0	71.0	N/A	177.3
2020	N/A	63.1	40.0	76.9	60.0	177.3
2021	N/A	53.5	41.0	76.6	57.0	177.3
2022	28.2	59.1	45.0	91.7	56.0	177.3
2023	38.9	70.5	63.0	95.5	67.0	177.3
2024	43.6	76.2	53.0	105.2	69.5	177.3
2025	49.8	100.8	82.0	107.1	84.9	177.3
2026	64.0	87.2	75.0	94.1	80.1	177.3
2027	66.5	99.6	72.0	91.7	82.5	177.3
2028	68.3	92.0	67.0	94.7	80.5	177.3
2029	64.2	97.8	73.0	101.0	84.0	177.3
2030	71.8	95.6	71.0	96.0	83.6	177.3
2031	78.2	94.5	84.0	101.4	89.5	173.4
2032	74.7	87.4	76.0	95.8	83.5	169.5
2033	74.5	88.9	78.0	96.3	84.4	165.5
2034	74.5	88.4	82.0	90.7	83.9	161.6
2035	73.5	87.9	86.0	91.4	84.7	157.6
2036	77.2	93.2	N/A	92.2	87.5	153.7
2037	78.2	92.6	N/A	92.4	87.7	149.8
2038	82.3	92.1	N/A	93.1	89.2	145.8
2039	83.2	91.6	N/A	93.3	89.4	141.9
2040	88.3	91.1	N/A	93.8	91.1	137.9
2041	N/A	90.5	N/A	93.8	92.2	134.0
2042	N/A	90.0	N/A	93.8	91.9	130.0
2043	N/A	95.1	N/A	93.8	94.5	126.1
2044	N/A	94.6	N/A	93.8	94.2	122.2
2045	N/A	94.1	N/A	93.8	94.0	118.2
2046	N/A	93.6	N/A	93.8	93.7	114.3
2047	N/A	93.0	N/A	93.8	93.4	110.3
2048	N/A	92.5	N/A	93.8	93.2	106.4
2049	N/A	97.5	N/A	93.8	95.6	102.5
2050	N/A	96.9	N/A	93.8	95.4	98.5



LEBRETON FLATS ZERO CARBON COMMUNITY ENERGY PLAN

GHG Emissions Factors

Year	IESO (gCO ₂ e/kWh)	OPG (gCO ₂ e/kWh)	TAF (gCO ₂ e/kWh)	PSPC (gCO ₂ e/kWh)	LBF (gCO ₂ e/kWh)	Gas (gCO ₂ e/kWh)
2051	N/A	96.4	N/A	93.8	95.1	94.6
2052	N/A	95.9	N/A	93.8	94.9	90.6
2053	N/A	95.4	N/A	93.8	94.6	86.7
2054	N/A	94.9	N/A	93.8	94.4	82.8
2055	N/A	99.6	N/A	93.8	96.7	78.8
2056	N/A	N/A	N/A	93.8	91.9	74.9
2057	N/A	N/A	N/A	93.8	87.1	70.9
2058	N/A	N/A	N/A	93.8	82.2	67.0
2059	N/A	N/A	N/A	93.8	77.4	63.1
2060	N/A	N/A	N/A	93.8	72.5	59.1
2061	N/A	N/A	N/A	N/A	67.7	55.2
2062	N/A	N/A	N/A	N/A	62.9	51.2
2063	N/A	N/A	N/A	N/A	58.0	47.3
2064	N/A	N/A	N/A	N/A	53.2	43.3
2065	N/A	N/A	N/A	N/A	48.4	39.4
2066	N/A	N/A	N/A	N/A	43.5	35.5
2067	N/A	N/A	N/A	N/A	38.7	31.5
2068	N/A	N/A	N/A	N/A	33.9	27.6
2069	N/A	N/A	N/A	N/A	29.0	23.6
2070	N/A	N/A	N/A	N/A	24.2	19.7
2071	N/A	N/A	N/A	N/A	19.3	15.8
2072	N/A	N/A	N/A	N/A	14.5	11.8
2073	N/A	N/A	N/A	N/A	9.7	7.9
2074	N/A	N/A	N/A	N/A	4.8	3.9
2075	N/A	N/A	N/A	N/A	0.0	0.0
2076	N/A	N/A	N/A	N/A	0.0	0.0
2077	N/A	N/A	N/A	N/A	0.0	0.0
2078	N/A	N/A	N/A	N/A	0.0	0.0
2079	N/A	N/A	N/A	N/A	0.0	0.0
2080	N/A	N/A	N/A	N/A	0.0	0.0
2081	N/A	N/A	N/A	N/A	0.0	0.0
2082	N/A	N/A	N/A	N/A	0.0	0.0
2083	N/A	N/A	N/A	N/A	0.0	0.0
2084	N/A	N/A	N/A	N/A	0.0	0.0
2085	N/A	N/A	N/A	N/A	0.0	0.0
2086	N/A	N/A	N/A	N/A	0.0	0.0



LEBRETON FLATS ZERO CARBON COMMUNITY ENERGY PLAN

GHG Emissions Factors

Year	IESO (gCO ₂ e/kWh)	OPG (gCO ₂ e/kWh)	TAF (gCO ₂ e/kWh)	PSPC (gCO ₂ e/kWh)	LBF (gCO ₂ e/kWh)	Gas (gCO ₂ e/kWh)
2087	N/A	N/A	N/A	N/A	0.0	0.0
2088	N/A	N/A	N/A	N/A	0.0	0.0
2089	N/A	N/A	N/A	N/A	0.0	0.0
2090	N/A	N/A	N/A	N/A	0.0	0.0
2091	N/A	N/A	N/A	N/A	0.0	0.0
2092	N/A	N/A	N/A	N/A	0.0	0.0
2093	N/A	N/A	N/A	N/A	0.0	0.0
2094	N/A	N/A	N/A	N/A	0.0	0.0
2095	N/A	N/A	N/A	N/A	0.0	0.0
2096	N/A	N/A	N/A	N/A	0.0	0.0
2097	N/A	N/A	N/A	N/A	0.0	0.0
2098	N/A	N/A	N/A	N/A	0.0	0.0
2099	N/A	N/A	N/A	N/A	0.0	0.0
2100	N/A	N/A	N/A	N/A	0.0	0.0
2101	N/A	N/A	N/A	N/A	0.0	0.0
2102	N/A	N/A	N/A	N/A	0.0	0.0
2103	N/A	N/A	N/A	N/A	0.0	0.0
2104	N/A	N/A	N/A	N/A	0.0	0.0
2105	N/A	N/A	N/A	N/A	0.0	0.0
2106	N/A	N/A	N/A	N/A	0.0	0.0
2107	N/A	N/A	N/A	N/A	0.0	0.0
2108	N/A	N/A	N/A	N/A	0.0	0.0
2109	N/A	N/A	N/A	N/A	0.0	0.0
2110	N/A	N/A	N/A	N/A	0.0	0.0



Appendix E **ANNUAL UTILITY RATES**

All prices in \$2020 CAD.



LEBRETON FLATS ZERO CARBON COMMUNITY ENERGY PLAN

Annual Utility Rates

Year	HOEP (\$/MWh)	Building Electricity (\$/MWh)	DES Demand (\$/kW)	DES Electricity (\$/MWh)	EIA Henry Hub (\$/MMBTU)	Building Gas (\$/m ³)	RNG (\$/m ³)	Water (\$/m ³)
2021	\$16.86	\$101.04	\$9.673	\$16.87	\$3.34	\$0.308	\$1.08	\$4.01
2022	\$17.86	\$107.03	\$9.673	\$17.87	\$3.57	\$0.328	\$1.08	\$4.13
2023	\$20.79	\$124.59	\$9.673	\$20.80	\$3.81	\$0.358	\$1.08	\$4.25
2024	\$22.16	\$132.80	\$9.673	\$22.17	\$4.05	\$0.386	\$1.08	\$4.38
2025	\$23.82	\$142.75	\$9.673	\$23.83	\$4.29	\$0.413	\$1.08	\$4.51
2026	\$27.51	\$164.86	\$9.673	\$27.52	\$4.52	\$0.439	\$1.08	\$4.65
2027	\$28.36	\$169.96	\$9.673	\$28.37	\$4.76	\$0.464	\$1.08	\$4.79
2028	\$29.62	\$177.51	\$9.673	\$29.63	\$5.00	\$0.487	\$1.08	\$4.93
2029	\$29.94	\$179.43	\$9.673	\$29.95	\$5.23	\$0.510	\$1.08	\$5.08
2030	\$32.27	\$193.39	\$9.673	\$32.28	\$5.47	\$0.531	\$1.08	\$5.23
2031	\$34.34	\$205.80	\$9.673	\$34.35	\$5.71	\$0.527	\$1.08	\$5.39
2032	\$33.46	\$200.52	\$9.673	\$33.47	\$5.88	\$0.522	\$1.08	\$5.55
2033	\$33.91	\$203.22	\$9.673	\$33.92	\$6.06	\$0.518	\$1.08	\$5.72
2034	\$33.03	\$197.94	\$9.673	\$33.04	\$6.23	\$0.513	\$1.08	\$5.89
2035	\$33.06	\$198.12	\$9.673	\$33.07	\$6.41	\$0.509	\$1.08	\$6.07
2036	\$34.21	\$205.02	\$9.673	\$34.22	\$6.58	\$0.505	\$1.08	\$6.25
2037	\$35.12	\$210.47	\$9.673	\$35.13	\$6.75	\$0.500	\$1.08	\$6.43
2038	\$36.44	\$218.38	\$9.673	\$36.45	\$6.93	\$0.496	\$1.08	\$6.63
2039	\$37.24	\$223.17	\$9.673	\$37.25	\$7.10	\$0.492	\$1.08	\$6.83
2040	\$38.42	\$230.25	\$9.673	\$38.43	\$7.28	\$0.487	\$1.08	\$7.03
2041	N/A	\$236.64	\$9.673	\$39.50	\$7.45	\$0.485	\$1.08	\$7.24
2042	N/A	\$243.21	\$9.673	\$40.60	\$7.72	\$0.482	\$1.08	\$7.46
2043	N/A	\$249.96	\$9.673	\$41.72	\$7.98	\$0.479	\$1.08	\$7.68
2044	N/A	\$256.89	\$9.673	\$42.88	\$8.25	\$0.476	\$1.08	\$7.91
2045	N/A	\$264.02	\$9.673	\$44.07	\$8.51	\$0.473	\$1.08	\$8.15
2046	N/A	\$271.35	\$9.673	\$45.30	\$8.78	\$0.470	\$1.08	\$8.40
2047	N/A	\$278.88	\$9.673	\$46.55	\$9.04	\$0.467	\$1.08	\$8.65
2048	N/A	\$286.62	\$9.673	\$47.85	\$9.31	\$0.464	\$1.08	\$8.91
2049	N/A	\$294.58	\$9.673	\$49.17	\$9.57	\$0.461	\$1.08	\$9.17
2050	N/A	\$302.75	\$9.673	\$50.54	\$9.84	\$0.458	\$1.08	\$9.45
2051	N/A	\$311.16	\$9.673	\$51.94	N/A	\$0.456	\$1.08	\$9.73
2052	N/A	\$319.79	\$9.673	\$53.38	N/A	\$0.454	\$1.08	\$10.03
2053	N/A	\$328.67	\$9.673	\$54.86	N/A	\$0.453	\$1.08	\$10.33
2054	N/A	\$337.79	\$9.673	\$56.39	N/A	\$0.452	\$1.08	\$10.64



LEBRETON FLATS ZERO CARBON COMMUNITY ENERGY PLAN

Annual Utility Rates

Year	HOEP (\$/MWh)	Building Electricity (\$/MWh)	DES Demand (\$/kW)	DES Electricity (\$/MWh)	EIA Henry Hub (\$/MMBTU)	Building Gas (\$/m ³)	RNG (\$/m ³)	Water (\$/m ³)
2055	N/A	\$347.17	\$9.673	\$57.95	N/A	\$0.450	\$1.08	\$10.95
2056	N/A	\$356.80	\$9.673	\$59.56	N/A	\$0.449	\$1.08	\$11.28
2057	N/A	\$366.71	\$9.673	\$61.21	N/A	\$0.448	\$1.08	\$11.62
2058	N/A	\$376.89	\$9.673	\$62.91	N/A	\$0.447	\$1.08	\$11.97
2059	N/A	\$387.35	\$9.673	\$64.66	N/A	\$0.447	\$1.08	\$12.33
2060	N/A	\$398.10	\$9.673	\$66.45	N/A	\$0.446	\$1.08	\$12.70
2061	N/A	\$409.15	\$9.673	\$68.30	N/A	\$0.445	\$1.08	\$13.08
2062	N/A	\$420.50	\$9.673	\$70.19	N/A	\$0.445	\$1.08	\$13.47
2063	N/A	\$432.17	\$9.673	\$72.14	N/A	\$0.444	\$1.08	\$13.88
2064	N/A	\$444.17	\$9.673	\$74.14	N/A	\$0.444	\$1.08	\$14.29
2065	N/A	\$456.50	\$9.673	\$76.20	N/A	\$0.444	\$1.08	\$14.72
2066	N/A	\$469.17	\$9.673	\$78.32	N/A	\$0.444	\$1.08	\$15.16
2067	N/A	\$482.19	\$9.673	\$80.49	N/A	\$0.444	\$1.08	\$15.62
2068	N/A	\$495.57	\$9.673	\$82.73	N/A	\$0.444	\$1.08	\$16.09
2069	N/A	\$509.33	\$9.673	\$85.02	N/A	\$0.444	\$1.08	\$16.57
2070	N/A	\$523.46	\$9.673	\$87.38	N/A	\$0.444	\$1.08	\$17.07
2071	N/A	\$537.99	\$9.673	\$89.81	N/A	\$0.445	\$1.08	\$17.58
2072	N/A	\$552.93	\$9.673	\$92.30	N/A	\$0.445	\$1.08	\$18.11
2073	N/A	\$568.27	\$9.673	\$94.86	N/A	\$0.446	\$1.08	\$18.65
2074	N/A	\$584.04	\$9.673	\$97.49	N/A	\$0.446	\$1.08	\$19.21
2075	N/A	\$600.26	\$9.673	\$100.20	N/A	\$0.447	\$1.08	\$19.79
2076	N/A	\$616.92	\$9.673	\$102.98	N/A	\$0.448	\$1.08	\$20.38
2077	N/A	\$634.04	\$9.673	\$105.84	N/A	\$0.449	\$1.08	\$20.99
2078	N/A	\$651.64	\$9.673	\$108.78	N/A	\$0.450	\$1.08	\$21.62
2079	N/A	\$669.72	\$9.673	\$111.80	N/A	\$0.451	\$1.08	\$22.27
2080	N/A	\$688.31	\$9.673	\$114.90	N/A	\$0.453	\$1.08	\$22.94
2081	N/A	\$707.42	\$9.673	\$118.09	N/A	\$0.454	\$1.08	\$23.63
2082	N/A	\$727.05	\$9.673	\$121.37	N/A	\$0.456	\$1.08	\$24.33
2083	N/A	\$747.23	\$9.673	\$124.73	N/A	\$0.457	\$1.08	\$25.06
2084	N/A	\$767.97	\$9.673	\$128.20	N/A	\$0.459	\$1.08	\$25.82
2085	N/A	\$789.29	\$9.673	\$131.75	N/A	\$0.461	\$1.08	\$26.59
2086	N/A	\$811.19	\$9.673	\$135.41	N/A	\$0.463	\$1.08	\$27.39
2087	N/A	\$833.71	\$9.673	\$139.17	N/A	\$0.465	\$1.08	\$28.21
2088	N/A	\$856.85	\$9.673	\$143.03	N/A	\$0.467	\$1.08	\$29.06



LEBRETON FLATS ZERO CARBON COMMUNITY ENERGY PLAN

Annual Utility Rates

Year	HOEP (\$/MWh)	Building Electricity (\$/MWh)	DES Demand (\$/kW)	DES Electricity (\$/MWh)	EIA Henry Hub (\$/MMBTU)	Building Gas (\$/m ³)	RNG (\$/m ³)	Water (\$/m ³)
2089	N/A	\$880.63	\$9.673	\$147.00	N/A	\$0.469	\$1.08	\$29.93
2090	N/A	\$905.07	\$9.673	\$151.08	N/A	\$0.471	\$1.08	\$30.83
2091	N/A	\$930.19	\$9.673	\$155.28	N/A	\$0.474	\$1.08	\$31.75
2092	N/A	\$956.01	\$9.673	\$159.59	N/A	\$0.476	\$1.08	\$32.70
2093	N/A	\$982.54	\$9.673	\$164.02	N/A	\$0.479	\$1.08	\$33.68
2094	N/A	\$1,009.82	\$9.673	\$168.57	N/A	\$0.482	\$1.08	\$34.69
2095	N/A	\$1,037.84	\$9.673	\$173.25	N/A	\$0.485	\$1.08	\$35.74
2096	N/A	\$1,066.65	\$9.673	\$178.05	N/A	\$0.488	\$1.08	\$36.81
2097	N/A	\$1,096.25	\$9.673	\$183.00	N/A	\$0.491	\$1.08	\$37.91
2098	N/A	\$1,126.68	\$9.673	\$188.08	N/A	\$0.494	\$1.08	\$39.05
2099	N/A	\$1,157.95	\$9.673	\$193.30	N/A	\$0.497	\$1.08	\$40.22
2100	N/A	\$1,190.09	\$9.673	\$198.66	N/A	\$0.501	\$1.08	\$41.43
2101	N/A	\$1,223.12	\$9.673	\$204.17	N/A	\$0.504	\$1.08	\$42.67
2102	N/A	\$1,257.07	\$9.673	\$209.84	N/A	\$0.508	\$1.08	\$43.95
2103	N/A	\$1,291.96	\$9.673	\$215.67	N/A	\$0.512	\$1.08	\$45.27
2104	N/A	\$1,327.82	\$9.673	\$221.65	N/A	\$0.515	\$1.08	\$46.63
2105	N/A	\$1,364.68	\$9.673	\$227.80	N/A	\$0.519	\$1.08	\$48.03
2106	N/A	\$1,402.55	\$9.673	\$234.13	N/A	\$0.524	\$1.08	\$49.47
2107	N/A	\$1,441.48	\$9.673	\$240.63	N/A	\$0.528	\$1.08	\$50.95
2108	N/A	\$1,481.49	\$9.673	\$247.30	N/A	\$0.532	\$1.08	\$52.48
2109	N/A	\$1,522.61	\$9.673	\$254.17	N/A	\$0.537	\$1.08	\$54.05
2110	N/A	\$1,564.87	\$9.673	\$261.22	N/A	\$0.541	\$1.08	\$55.67



LEBRETON FLATS ZERO CARBON COMMUNITY ENERGY PLAN

DES Thermal Loads

Appendix F DES THERMAL LOADS

Year	Total Floor Area (m ²)	Space Heating - Option A		Space Cooling - Option A		DHW - Option A		Space Heating - Option C		Space Cooling - Option C		DHW - Option C	
		Demand (kW _{th})	Energy (MWh _{th})	Demand (kW _{th})	Energy (MWh _{th})	Demand (kW _{th})	Energy (MWh _{th})	Demand (kW _{th})	Energy (MWh _{th})	Demand (kW _{th})	Energy (MWh _{th})	Demand (kW _{th})	Energy (MWh _{th})
2025	0	0	0	0	0	0	0	0	0	0	0	0	0
2026	5,198	204	257	222	224	32	96	126	131	145	172	22	66
2027	12,996	509	643	554	561	80	240	314	327	364	430	55	165
2028	22,093	865	1,094	943	953	136	409	535	556	618	731	93	281
2029	35,089	1,374	1,737	1,497	1,513	215	649	849	884	982	1,162	148	446
2030	53,283	2,086	2,637	2,273	2,298	327	985	1,289	1,342	1,491	1,764	225	677
2031	76,675	3,002	3,795	3,271	3,307	471	1,418	1,855	1,931	2,145	2,539	323	974
2032	105,266	4,122	5,210	4,491	4,540	646	1,947	2,547	2,651	2,945	3,485	444	1,337
2033	149,452	5,852	7,397	6,376	6,446	917	2,764	3,616	3,763	4,181	4,948	630	1,898
2034	191,642	7,504	9,486	8,176	8,265	1,176	3,544	4,637	4,826	5,361	6,345	808	2,434
2035	204,963	8,035	10,149	8,762	8,862	1,259	3,793	4,966	5,173	5,737	6,787	865	2,605
2036	218,285	8,565	10,813	9,347	9,458	1,342	4,043	5,295	5,520	6,112	7,230	921	2,776
2037	231,606	9,096	11,477	9,932	10,054	1,425	4,292	5,624	5,867	6,487	7,672	978	2,947
2038	244,928	9,627	12,141	10,517	10,650	1,507	4,541	5,954	6,213	6,863	8,115	1,035	3,119
2039	258,249	10,157	12,805	11,102	11,247	1,590	4,791	6,283	6,560	7,238	8,557	1,092	3,290
2040	271,571	10,688	13,469	11,687	11,843	1,673	5,040	6,612	6,907	7,613	8,999	1,149	3,461
2041	284,892	11,218	14,133	12,272	12,439	1,756	5,289	6,941	7,254	7,989	9,442	1,206	3,632
2042	298,213	11,749	14,796	12,857	13,036	1,838	5,539	7,271	7,601	8,364	9,884	1,262	3,804
2043	311,535	12,280	15,460	13,442	13,632	1,921	5,788	7,600	7,948	8,739	10,327	1,319	3,975
2044	324,856	12,810	16,124	14,028	14,228	2,004	6,037	7,929	8,295	9,115	10,769	1,376	4,146
2045	369,042	14,502	14,560	15,829	19,420	2,270	6,840	8,961	7,288	10,338	14,743	1,559	4,697
2046	413,228	16,187	16,277	17,631	21,610	2,536	7,642	9,995	8,103	11,560	16,495	1,742	5,248
2047	454,814	17,773	17,892	19,327	23,671	2,787	8,397	10,969	8,870	12,711	18,143	1,914	5,766
2048	488,603	19,062	19,204	20,705	25,346	2,991	9,011	11,760	9,494	13,646	19,483	2,054	6,188
2049	506,797	19,756	19,911	21,447	26,248	3,100	9,341	12,186	9,829	14,150	20,204	2,129	6,414
2050	514,595	20,054	20,214	21,765	26,635	3,147	9,482	12,368	9,973	14,366	20,513	2,161	6,512
2051	519,832	20,253	20,417	21,979	26,894	3,179	9,578	12,491	10,070	14,511	20,721	2,183	6,577

