



**ESSO Station at 1545 Woodroffe
Avenue at Medhurst Drive**

SITE SERVICING & STORMWATER MANAGEMENT REPORT

City of Ottawa

**Prepared for Imperial Oil Limited
c/o AMEC Americas Ltd.**

April 2015



1750 Courtwood Crescent Suite 220
Ottawa Ontario K2C 2B5 Canada
Tel 613 226 1844 Fax 613 226 8930
www.rvanderson.com

SITE SERVICING & STORMWATER MANAGEMENT REPORT

1545 WOODROFFE AVE. AND MEDHURST DR.

City of Ottawa

Prepared for:

Imperial Oil Limited

c/o AMEC Americas Ltd.

"This report is protected by copyright and was prepared by R.V. Anderson Associates Limited for the account of AMEC Americas Ltd. and for use by the City of Ottawa. It shall not be copied without permission. The material in it reflects our best judgment in light of the information available to R.V. Anderson Associates Limited at the time of preparation. Any use which a third party makes of this report, or any reliance on or decisions to be made based on it, are the responsibility of such third parties. R.V. Anderson Associates Limited accepts no responsibility for damages, if any, suffered by any third party as a result of decisions made or actions based on this report."



1750 Courtwood Crescent Suite 220
Ottawa Ontario K2C 2B5 Canada
Tel 613 226 1844 Fax 613 226 8930
www.rvanderson.com

RVA 143055

April 2015

TABLE OF CONTENTS

1.0	INTRODUCTION	2
2.0	BACKGROUND	2
2.1	Site Location	2
2.2	Existing Condition	3
2.3	Proposed Condition	5
3.0	STORMWATER MANAGEMENT PLAN	6
3.1	Storm Drainage Criteria	6
3.2	Water Balance	7
3.3	Stormwater Management Rate Control (Quantity)	9
3.3.1	PROPOSED STORMWATER DETENTION	11
3.3.2	CALCULATION METHODOLOGY	12
3.4	Stormwater Quality	14
4.0	MAINTENANCE	14
5.0	EROSION & SEDIMENT	14
6.0	SANITARY SERVICING	14
7.0	WATER SERVICING	15
8.0	CONCLUSION	15

1.0 INTRODUCTION

Imperial Oil Limited is proposing a site re-development of an existing ESSO gas station located at 1545 Woodroffe Avenue in the City of Ottawa. The site in its proposed condition will be an ESSO gas station, consisting of a convenience store with five (5) fueling islands and ten (10) fueling positions under a canopy, a carwash, and surface parking.

AMEC Americas Inc., on behalf of Imperial Oil Limited, have retained R.V. Anderson Associates Limited to prepare a site grading and servicing plan and site stormwater management report to support the Site Plan Approval of the proposed re-development. The scope of this report specifically includes:

- identification of existing drainage from the site;
- identification of storm drainage / stormwater management criteria for the development of the site;
- recommendation and description of proposed storm stormwater management system for the site;
- calculation of allowable post-development peak discharge rates;
- calculation of actual post-development peak discharge rates and stormwater detention requirements, if any; and
- proposal of appropriate method(s) to address applicable stormwater quality, water balance and erosion and sediment control requirements.

2.0 BACKGROUND

2.1 Site Location

The proposed ESSO site is 0.7320 hectares in size, and is located on the north east corner of the Woodroffe Avenue and Medhurst Drive intersection in the City of Ottawa. The property is bound by residential properties to both the north and east.

Refer to Figure 1 – Key Plan for the general site location



Figure 1: Key Plan

2.2 Existing Condition

The existing site consists of eight (12) fueling positions underneath a canopy with a convenience store, a Tim Hortons, and a car wash.

The site currently has three driveway entrances: two (2) entrances from Woodroffe Avenue, and one (1) entrance from Medhurst Drive.

The adjacent north property is separated from the site by a vegetated easement 3.0m wide and a triangular allowance ranging from 15m wide in the west to 0m in the east. The adjacent property to the east is separated from the site with a wooden fence.

Surface drainage along the west portion of the existing parking lot is partially serviced by two catchbasins near the two western entrances, however poor sloping appears to allow a large portion of the runoff to drain overland to the Woodroffe Avenue right-of-way via the two western entrances to the site. The majority of the remaining asphalt surface of the existing ESSO station is self-contained and drains to two (2) additional on site catchbasins located at low points within the parking area of the site. The catch basin system onsite The storm system onsite discharges through a 300mm diameter storm sewer that connects to a maintenance hole on the 1050mm diameter storm sewer on Medhurst Drive. The municipal storm sewer connects to an 1800mm diameter storm sewer a short distance away, which crosses Woodroffe avenue where it then connects to a 2400mm diameter storm sewer that flows north eventually discharging to Pinecrest Creek.

In its existing condition, the site is comprised of a mix of pervious and impervious areas in the following proportions.

- Pervious – 34%
- Surface Impervious – 55%
- Roof Impervious – 11%

Run-off coefficients of 0.20 for landscaped surfaces, 0.90 for asphalt/concrete surfaces, and 0.95 for roof surfaces were used to calculate the weighted 'C' value. This results in a weighted 'C' value of 0.70. Table 1 indicates the area and associated rainwater run-off coefficient for each type of proposed surface treatment.

Table 1: Existing Run-Off Coefficient

Surface Treatment	Run-off Coefficient 'C'	Existing Condition Area (m ²)	A x C (m ²)
Surface Impervious	0.90	4295	3866
Pervious	0.20	2177	435
Roof	0.95	848	806
Total Area		7320	5107
Weighted "C" Value			0.70

2.3 Proposed Condition

The proposed ESSO station site redevelopment will consist of a new convenience store with a drive-thru, five (5) fuel pumps under a canopy, a drive-thru car wash, and on-site surface parking.

Driveway access to the proposed site will remain as two (2) entrances from Woodroffe Avenue, and one (1) entrance from Medhurst Drive, generally conforming to the existing conditions.

In its proposed condition, the site will be comprised of a mix of pervious and impervious areas in the following proportions:

- Grass – 30%
- Surface Impervious – 59%
- Roof Impervious – 11%

Run-off coefficients of 0.2 for landscaped surfaces and 0.90 for surface impervious, and 0.95 for roof impervious surfaces were used to calculate the weighted 'C' value for a 5-year return period storm, while the runoff coefficients were increased by 25% for the 100-year storm as per the City of Ottawa's Design Guidelines. This results in a weighted 'C' value of 0.70 for the 5-year storm, and 0.78 for the 100-year storm. Table 2 indicates the area and associated rainwater run-off coefficient for each type of proposed surface treatment.

Table 2: Proposed Run-Off Coefficient

Surface Treatment	Proposed Condition Area (m ²)	5 year Run-off Coefficients 'C'	5 year Weighted Runoff Coefficients 'CxA'	100 year Run-off Coefficients 'C'	100 year Weighted Runoff Coefficients 'CxA'
Grass	2189	0.20	438	0.25	547
Impervious Surface	4358	0.90	3922	1.0	4358
Roof	773	0.95	734	1.0	773
Total Area	7320		5094		5678
Weighted "C" Value (controlled)			0.70		0.78

3.0 STORMWATER MANAGEMENT PLAN

3.1 Storm Drainage Criteria

Based on the City of Ottawa's Site Servicing Guidelines, and per the Stormwater Management Guidelines for the Pinecrest Creek / Westboro Area, the following SWM criteria is proposed for the subject site:

- The post development site during a 5-year to 100-year storm peak discharge rate to the municipal sewer must be controlled to the more stringent of: 5-year return period storm with a runoff coefficient of 0.5, or 33.5L/s/ha
- 5.8L/s/ha for a 25mm Chicago design storm
- In the event of storm events that exceed the 100-year design storm, a safe overland flow route to be provided for the proposed development without causing damage to the proposed and adjacent public and private properties;
- Water Quality – Provide long-term average removal of 80% of Total Suspended Solids on an annual loading basis from the post-development site in accordance with MOE SWM Enhanced Protection Level;
- Water Balance – The SWM plan must make every feasible effort to minimize changes in the water balance between pre-development and post-development conditions and shall provide a minimum infiltration equivalent to the first 10 mm of any given rainfall event;
- Maintain existing drainage patterns, ensuring adjacent properties are not altered;
- Stormwater runoff from the subject development shall not be directed to drain onto adjacent properties;

The IDF curve information for the I_5 and I_{100} storm events as obtained from the City of Ottawa Design Guidelines are as follows:

$$I_5 \text{ (mm/hr)} = 998.071 / (T + 6.053)^{0.814}$$

$$I_{100} \text{ (mm/hr)} = 1735.688 / (T + 6.014)^{0.820}$$

The 25mm 4 hour Chicago Storm intensities are shown below:

Table 3: 4 hour 25mm Chicago Storm

Time (min)	Intensity (mm/hr)	Time (min)	Intensity (mm/hr)	Time (min)	Intensity (mm/hr)	Time (min)	Intensity (mm/hr)
10	2.07	70	5.70	130	5.19	190	2.80
20	2.27	80	10.78	140	4.47	200	2.62
30	2.52	90	50.21	150	3.95	210	2.48
40	2.88	100	13.37	160	3.56	220	2.35
50	3.38	110	8.29	170	3.25	230	2.23
60	4.18	120	6.30	180	3.01	240	2.14

3.2 Water Balance

The Stormwater Management Guidelines for the Pinecrest Creek / Westboro Area target for water balance is to minimize any anticipated changes in the water balance between pre-development and post-development conditions and shall provide a minimum infiltration equivalent to the first 10mm of any given rainfall event.

Several alternatives have been considered to achieve the Water Balance target of 10 mm across the entire site. The following is a brief description and comment of three different approaches.

- 1) The use of permeable pavers was considered. However, considering the use of the site and the high potential for the infiltration of hazardous/contaminant materials such as gas and oil into the subsurface in the event of a spill, this options is not considered appropriate for this site.
- 2) Harvesting of rainwater for irrigation was considered. However, there is little landscaping that would require irrigation and warrant a sufficient demand for the installation and operation of the associated tank and pumping system.
- 3) Direct infiltration/exfiltration of solely roof canopy runoff into a buried exfiltration gallery sized to produce a total water balance of 10 mm across the entire site. The exfiltration gallery would be comprised of open bottom thermal plastic arch units, and would be

connected downstream of the site orifice control to help protect against surcharging and fitted with a backwater valve as an additional protection measure.

Such a system could serve to meet the water balance and provide a level of protection against contaminated water being infiltrated into the ground (canopy roof runoff only). However, we remain concerned that introducing water directly into the ground and therefore promoting the movement of subsurface water movement on a site with this use is not appropriate, as that movement of water may transport contaminants that may work their way into the ground.

- 4) Directing roof top drainage direction to pervious landscaped surfaces would serve to improve the water balance to the extent that the landscaped areas could surface infiltrate the additional runoff. Unfortunately due to the inherent functional requirements of the site rooftops, with exception of the carwash, none of the roofs are adjacent to landscaped surfaces.

In summary, the available measures to achieve the water balance targets are not appropriate for the site considering its use and size.

- 5) It is however proposed to direct the carwash roof downspouts to the sodded/landscaped area adjacent to the carwash. This will help promote additional infiltration.

Table 3 provides a summary of estimated surface initial abstraction (IA) values, or depths of precipitation that doesn't convert to runoff for the pre-development site. Based on this table it is estimated that 2.53mm of daily rain will be infiltrated, evaporated or transpired from the existing site, whereas in the site's post-development condition, it is estimated that 2.53 mm of daily rainfall will be infiltrated, evaporated or transpired. In conclusion, although the post-development site does not achieve the target 10.0mm across the entire site, the water balance across the site will not significantly change between the pre-development conditions.

Table 4: Pre-Development Water Balance

	Area (sq.m)	% of Total Site Area	Surface IA (mm)	Effective IA (mm) over Site Area
Pre-Development Areas				
Grass	2177	30%	4.76	1.43
Roof	848	12%	1.57	0.19
Concrete/Asphalt	4295	58%	1.57	0.91
Total	7320	100%		2.53

Table 5: Post-Development Water Balance

	Area (sq.m)	% of Total Site Area	Surface IA (mm)	Effective IA (mm) over Site Area
Development Areas				
Grass	2189	30%	4.76	1.43
Roof	773	11%	1.57	0.17
Concrete/Asphalt	4358	59%	1.57	0.93
Total	7320	100%		2.53 (25.3% of target)

3.3 Stormwater Management Rate Control (Quantity)

As indicated previously, the coefficient of run-off for the proposed site re-development is $C=0.70$. There are multiple scenarios that must be considered for this site based on the information provided in the pre-consultation meeting with the City of Ottawa. The first is to limit the peak discharge to the more stringent of: the peak discharge from a 5-year return period storm considering a runoff coefficient of $C=0.5$ as per the City of Ottawa Design Guidelines, or 33.5L/s/ha as per the SWM Guidelines for the Pinecrest Creek / Westboro Area. The second

scenario is to limit the peak discharge during the 25mm design storm such that the peak outflow does not exceed 5.8 L/s/ha as per the SWM Guidelines for the Pinecrest Creek / Westboro Area.

Consequently, the use of on-site stormwater detention is required to facilitate a maximum allowed discharge rates under the two scenarios.

Scenario #1 – Peak Flows

Criteria #1 – City of Ottawa Design Guidelines:

For the purpose of calculating the site discharge rates and required detention volumes for the storm events, the Rational Method was utilized to simulate site hydrology.

Using this method, the allowable post-development peak discharge rate for the site during the 5-year through 100-year storm events is summarized below.

The allowable peak discharge rate for this site is equal to the 5-year peak development flow controlled at a time of concentration of 10 minutes. Based on this time of concentration, the 5-year rainfall intensity can be calculated using Equation (1) from Section 3.0 as follows:

$$i_{5yr} = \frac{998.071}{(T+ 6.053) 0.814} = 104.19\text{mm/hr}$$

If the 5-year peak development flow is controlled to a runoff coefficient of 0.5 at a time of concentration of 10 minutes, the following flow would be allowable:

$$\begin{aligned} Q_{ALL} &= 0.5 \times 104.19\text{mm/hr} \times 7320\text{m}^2 / 3600 \\ Q_{ALL} &= 105.9 \text{ L/s} \end{aligned}$$

Criteria #2 – SWM Guidelines for the Pinecrest Creek / Westboro Area:

Based on the size of the site, this allowable runoff as per Scenario 1 corresponds to a discharge of 105.9L/s / 0.732ha = 144.7L/s/ha. As per the SWM Guidelines for the Pinecrest Creek / Westboro Area, the maximum discharge rate during a storm up to a 100-year return period is 33.5L/s/ha, which corresponds to 24.5L/s on the subject site.

Thus, Criteria #2 is the more stringent criteria, and this will be used to calculate the maximum site discharge rate.

Scenario #2 – Peak Discharge during a 25mm 4-hour Chicago Storm:

Based on the size of the site, this allowable runoff as per Scenario 2 corresponds to a discharge of $5.8\text{L/s/ha} \times 0.732\text{ha} = 4.2\text{L/s}$.

3.3.1 Proposed Stormwater Detention

Site grading has been designed so that the majority of the site drainage will be self-contained, conveying runoff to the on-site storm sewer system via the on-site catchbasins and catchbasin manholes.

There are relatively small landscaped areas (approximately 2189 m^2 in total) along the perimeter of the site. A relatively small portion of these landscaped areas will discharge in an uncontrolled manner as sheet drainage to the municipal right of way.

In addition to this, minor areas from the three entrance driveways drain uncontrolled overland to the municipal right-of-way.

The stormwater management quantity control system will consist of detention storage within the proposed underground storage tank. The site's peak discharge rate is to be controlled by an orifice plate / weir.

When the runoff captured by the onsite catchbasins is greater than the allowable peak discharge rate through the orifice pipe, the storm sewer system will surcharge and the excess runoff volume will be detained within the underground storage tank. In the event of a storm greater than the 100-year, the on-site storm system will overtop and spillover to the Woodroffe Avenue right-of-way via the driveway entrance at the northwest limit of the site.

Detention storage totalling 380 m^3 is provided within the underground storage tank. The discharge will be controlled through the use of a combination of a weir and two Hydrovex inlet control devices as described later in this report.

3.3.2 Calculation Methodology

Scenario#1 – 100 year event:

During the 100-year event, the peak flows from the uncontrolled surface can be calculated using a time of concentration of 10 minutes as follows:

$$I_{100} \text{ (mm/hr)} = 50.21$$

$$Q_{\text{free}_{\text{peak100yr}}} = C_{100} \times I_{100} \times A_{\text{free}} / 3600 = 0.47 \times 178.56 \text{ mm/hr} \times 509 \text{ m}^2 / 3600 = 11.9 \text{ L/s}$$

Based on the free flow discharge, the allowable discharge from the controlled surface is as follows:

$$Q_{\text{controlled}_{\text{peak100yr}}} = 24.5 \text{ L/s} - 11.9 \text{ L/s} = 12.6 \text{ L/s}$$

Scenario#2 – 25mm 4hr Chicago Storm:

The peak intensity during a 25mm 4-hour Chicago Storm is 50.21 mm/hr. Based on the properties of the free flowing area of the site, the peak free flow rate can be calculated as follows:

$$Q_{\text{free}_{\text{peak25mm}}} = 0.41 \times 50.21 \text{ mm/hr} \times 509 \text{ m}^2 / 3600 = 2.9 \text{ L/s}$$

Based on the free flow discharge, the allowable discharge from the controlled surface is as follows:

$$Q_{\text{controlled}_{\text{peak25mm}}} = 4.2 \text{ L/s} - 2.9 \text{ L/s} = 1.3 \text{ L/s}$$

Table 6 summarizes the post development peak flows resulting from the proposed on-site detention storage and orifice pipe / weir controlled discharge

Table 6: Post-Development Peak Discharge Rates and Required Storage

Storm Event	Peak Sewer Discharge from Orifice (L/s)	Uncontrolled Peak Discharge (L/s)	Total Peak Discharge (L/s)	Allowable Peak Discharge from Site (L/s)	Required Storage Volume (m ³)	Available Detention Storage Volume (m ³)
25 mm 4hr Chicago Storm	1.3	2.9	4.2	4.2	103.9	380.2
5 yr – Post-Development	12.6	6.1	18.7	25.4	116.3	380.2
100 yr – Post-Development	12.6	11.9	25.4	25.4	268.6	380.2*

*Note: Due to the requirement to limit the discharge on during a 25mm 4hr storm, total required storage is 372.5m³, as such, an additional 111.6m³ of storage has been provided to ensure adequate storage volume to limit the peak 100-year peak flow.

Stormwater Retention

As indicated in Table 6, the peak discharge from site will need to be limited to two rates based on the properties of the storm.

The first is the peak discharge during a 25mm Chicago Storm. The peak controlled outflow will be proposed orifice constructed within a weir. Based on the properties of the underground storage tank, the required storage will be achieved at a water level elevation of 85.65m. Thus the top of the weir will be constructed to this elevation. Based on the invert elevation at the weir (84.58m), the hydraulic head will be 1.07m. As such a Hydrovex 40 SVHV-1 inlet control device will be installed in the orifice within the weir to control the peak discharge to 1.3L/s.

The secondary peak discharge will be achieved during the 100-year storm. The peak discharge through the storm sewer system at the maximum storage/ponding elevation of 88.14m will be 12.6L/s. As such, the maximum head at the outlet will be 3.56m. As such, a Hydrovex 75 VHV-1 inlet control device will be installed in the outlet to CBMH#13 downstream of the weir.

Refer to Appendix D for the inlet control device specifications.

3.4 Stormwater Quality

The stormwater management quality control required is the removal of 80% of the long-term average total suspended sediment load from the site's run-off. A Stormceptor STC 750 oil-grit separator located downstream of the orifice controlled MH is proposed for this purpose.

4.0 MAINTENANCE

An ongoing maintenance program consisting of annual inspection and cleaning of the CB sumps is recommended (minimum once per year). As for the Stormceptor, it is recommended to follow the manufacturer's recommendations for maintenance.

5.0 EROSION & SEDIMENT

Erosion and sediment control measures (in accordance with the requirements of OPSS 805 – November 2010) consisting of both permanent and temporary measures shall be implemented prior to the commencement of construction activities to ensure that sediment is contained within the site. Permanent erosion control measures shall ensure that potential long-term and localized erosion problems are dealt with prior to their occurrence.

6.0 SANITARY SERVICING

The sanitary servicing to the proposed site will connect to the existing 300mm diameter sewer on Medhurst Drive. The connection will be made adjacent to the storm and water connections which will lead to only one road cut being required on Medhurst Drive.

The existing site is to be updated with similar facilities to the existing site. The flows from the car wash are expected to remain similar to the previous site's carwash, while the flows from the C-Store are expected to decrease due to the decreased size of the store area. Additionally, the newly constructed sewers are expected to remedy any existing infiltration in the existing sewers, leading to a decrease in the total infiltration to the system. As such, total sanitary flows from the site are expected to decrease. As such, it is anticipated that the existing sanitary sewer will have adequate capacity to convey the discharge from the site.

7.0 WATER SERVICING

The water servicing to the proposed site will be made adjacent to the storm and sanitary connections which will lead to only one road cut being required on Medhurst Drive. Additionally, the site will be serviced by the existing hydrant near the Northwest corner of the site.

The existing site is to be updated with similar facilities to the existing site. The flows to the car wash are expected to remain similar to the previous site's carwash, while the flows to the C-Store are expected to decrease due to the decreased size of the store area. As such, total water demand from the site is expected to decrease. As such, it is anticipated that the water system in the area will have adequate capacity provide the required flow to the site.

8.0 CONCLUSION

With respect to the development of the subject property located 1545 Woodroffe Avenue, the proposed stormwater drainage system will address the stormwater management requirements of the City of Ottawa, in that:

- The post development peak discharge during a 4-hour 25mm Chicago Storm will not exceed 5.8L/s/ha by installation of a weir with a Hydrovex 40 SVHV-1 inlet control device within the downstream maintenance hole.
- The post-development peak discharge rates will not exceed 33.5 L/s/ha during the 100-year storm event by installation of a Hydrovex 75 VHV-1 inlet control device at the outlet of the downstream maintenance hole.
- Detention of 380.2m³ of stormwater within an underground storage tank constructed with Atlantis Matrix Penta Tank Modules;
- A Stormceptor STC 750 stormwater treatment unit installed downstream of CBMH #12 will achieve 80% of the long-term average total suspended sediment load from the site's run-off based.
- The various pervious and hard surfaces of the site will provide an estimated "capture" of approximately 25.3% of the 10mm target. Available measures that could be implemented to achieve the target were examined and it was concluded that due to the site use and risk of groundwater contamination, these measures were not appropriate;

We trust that this report satisfies the requirements of the City of Ottawa with respect to the subject development. Should you have any questions, please do not hesitate to contact the undersigned.

R.V. ANDERSON ASSOCIATES LIMITED



Nate Rodgers, EIT
PROJECT DESIGNER

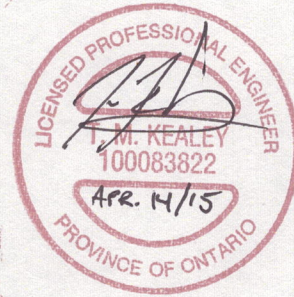

Reviewed By:
Trevor Kealey, P.Eng.
PROJECT MANAGER

APPENDIX A – Design Drawings

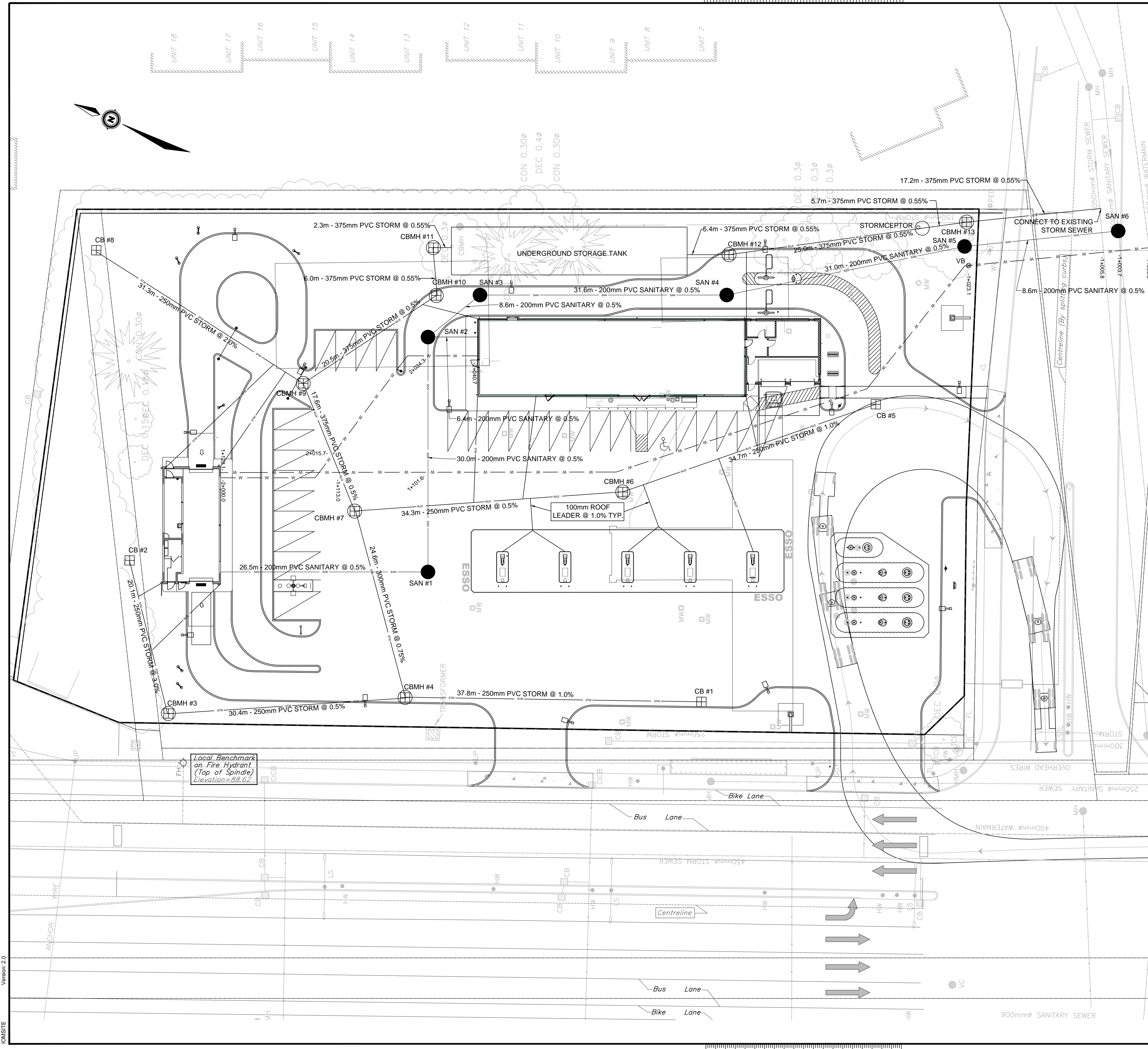

STORM INVERT SCHEDULE

STRUCTURE	TOP	INVERT	COMMENTS
CB#1	88.05	N = 86.30	NEW 600mm x 600mm CATCHBASIN AS PER OPSPD 705.010
CB#2	88.45	W = 86.70	NEW 600mm x 600mm CATCHBASIN AS PER OPSPD 705.010
CBM#3	87.85	E = 86.10 S = 86.04	NEW 1200mm DIAMETER MANHOLE WITH 300mm SUMP AS PER OPSPD 701.010
CBM#4	88.05	S = 85.92 N = 85.89 E = 85.83	NEW 1200mm DIAMETER MANHOLE WITH 300mm SUMP AS PER OPSPD 701.010
CB#5	88.30	N = 86.55	NEW 600mm x 600mm CATCHBASIN AS PER OPSPD 705.010
CBM#6	88.53	S = 86.20 N = 86.14	NEW 1200mm DIAMETER MANHOLE WITH 300mm SUMP AS PER OPSPD 701.010
CBM#7	88.30	S = 85.97 W = 85.65 E = 85.57	NEW 1200mm DIAMETER MANHOLE WITH 300mm SUMP AS PER OPSPD 701.010
CB#8	88.40	S = 86.65	NEW 600mm x 600mm CATCHBASIN AS PER OPSPD 705.010
CBM#9	88.50	N = 85.48 E = 84.82 E = 85.42	NEW 1200mm DIAMETER MANHOLE WITH 300mm SUMP AS PER OPSPD 701.010
CBM#10	88.63	NW = 85.32 S = 85.26	NEW 1200mm DIAMETER MANHOLE WITH 300mm SUMP AS PER OPSPD 701.010
CBM#11	88.40	W = 85.23	NEW 1200mm DIAMETER MANHOLE WITH 300mm SUMP AS PER OPSPD 701.010
UNDERGROUND STORAGE	VARIABLES	N = 85.21 S = 84.91	UNDERGROUND STORAGE TANK USING ATLANTIS MATRIX PENTA TANK MODULES. CAPACITY = 380m3
CBM#12	88.65	N = 85.88 E = 84.82 S = 84.68	NEW 1200mm DIAMETER MANHOLE WITH 300mm SUMP AS PER OPSPD 701.010
STORMCEPTOR	88.45	N = 84.68 S = 84.68	NEW STORMCEPTOR - MODEL STC 750
CBM#13	88.15	N = 84.65 S = 84.48	NEW 1200mm DIAMETER MANHOLE WITH 300mm SUMP AS PER OPSPD 701.010
EXISTING SEWER	87.96	N = 84.58 E = EXISTING	TIE INTO EXISTING SEWER AS PER S11

SANITARY INVERT SCHEDULE

STRUCTURE	TOP	INVERT	COMMENTS
CONNECTION TO CAR WASH	88.90	SEE MECHANICAL	CONNECT TO BUILDING SERVICES
SAN MH#1	88.50	N = 86.57 E = 86.51	NEW 1200mm DIAMETER MANHOLE AS PER OPSPD 701.010
CONNECTION TO C-STORE	89.03	SEE MECHANICAL	CONNECT TO BUILDING SERVICES
SAN MH#2	88.75	W = 86.36 S = 86.80 SE = 86.30	NEW 1200mm DIAMETER MANHOLE AS PER OPSPD 701.010
SAN MH#3	88.70	NW = 86.26 S = 86.20	NEW 1200mm DIAMETER MANHOLE AS PER OPSPD 701.010
SAN MH#4	88.80	N = 86.04 S = 85.98	NEW 1200mm DIAMETER MANHOLE AS PER OPSPD 701.010
SAN MH#5	88.20	N = 85.82 S = 85.76	NEW 1200mm DIAMETER MANHOLE AS PER OPSPD 701.010
SAN MH#6	87.92	N = 85.72 E = EXISTING W = EXISTING	NEW 1200mm DIAMETER MANHOLE AS PER OPSPD 701.010

PRIVATE WATERMAIN TABLE

STATION	DESCRIPTION	TOP OF PIPE ELEVATION	GROUND ELEVATION	COMMENTS
1+000.0	CONNECTION TO 300mm DIAMETER WATERMAIN	86.17	88.15	CONNECTION TO CITY SERVICES
1+003.7	SANITARY CROSSING	85.52	87.92	WATERMAIN CROSSES OVER SANITARY PER W25.2. CLEARANCE = 2.52m
1+005.8	STORM CROSSING	85.56	87.96	WATERMAIN CROSSES OVER STORM PER W25.2. CLEARANCE = 2.17m
1+023.1	VALVE BOX	85.88	88.28	NEW VALVE BOX PER W24
1+101.6	SANITARY CROSSING	87.00	88.60	WATERMAIN CROSSES OVER SANITARY PER W25.2. CLEARANCE = 0.25m
1+113.0	STORM CROSSING	86.27	88.34	WATERMAIN CROSSES OVER STORM PER W25.2. CLEARANCE = 0.25m
1+128.1	CONNECTION TO BUILDING	86.50	88.90	CONNECTION TO CARWASH BUILDING
2+000.0	CONNECTION TO BUILDING	86.50	88.90	CONNECTION TO CARWASH BUILDING
2+015.0	STORM CROSSING	86.25	88.35	WATERMAIN CROSSES OVER STORM PER W25.2. CLEARANCE = 0.25m
2+034.3	SANITARY CROSSING	86.87	88.77	WATERMAIN CROSSES OVER SANITARY PER W25.2. CLEARANCE = 0.25m
2+040.7	CONNECTION TO BUILDING	86.63	89.03	CONNECTION TO C-STORE BUILDING

LEGEND:

- EXISTING STORM SEWER
- EXISTING SANITARY SEWER
- EXISTING WATERMAIN
- PROPOSED WATERMAIN
- PROPOSED STORM SEWER
- PROPOSED SANITARY SEWER
- DRAINAGE AREA BOUNDARY
- DRAINAGE AREA BOUNDARY
- EXISTING FIRE HYDRANT
- EXISTING VALVE BOX
- EXISTING SAN MH
- EXISTING STM CB
- EXISTING STM MH
- PROPOSED SAN MH
- PROPOSED STM CBMH
- PROPOSED STM CB
- EXISTING ELEVATION
- PROPOSED ELEVATION

Imperial Oil
Esso
Imperial

FIELD MARKETING
ASSET MANAGEMENT - ENGINEERING SERVICES
MARKETING DES CALIBRANTS
GESTION DES ACTIFS - SERVICES D'INGENIERIE

90 WOODROFFE DRIVE
TORONTO, ONTARIO
M6C 1K5

Date	#	Revision
15 03 02	01	ISSUED FOR SITE PLAN APPROVAL
15 04 09	02	REVISED FOR COMMENTS

Project/Project
1345 WOODROFFE AVE. & MEDHURST DR
OTTAWA, ONTARIO

Title/Title
PROPOSED SITE SERVICES

Scale (227x347)
Echelle 1:250

Scale (113x171)
Echelle 1:500

Date
15 03 02

By/Par
RVA

PM/Sup
TMK

Sheet/Feuille
001

PBL No. PBL 0000302287-03P
SAP No. SAP 88001626-03P

Estimate
Proposition: 01

Rev. No./Rev.
02

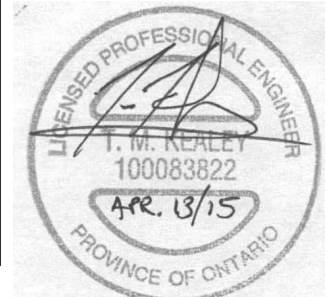

APPENDIX B – Sewer Design Sheets

1545 Woodroffe - STORM DESIGN SHEETS

RATIONAL METHOD CALCULATIONS

Pipe	From	To	Increment of Area	Total Area	Weighted Coefficient	A*c	Sum A*c	Increment of Time (min)	Total Time
1	CB#1	CBMH#4	1172	1172	0.91	1067	1067	0.52	10.52
2	CB#2	CBMH#3	96	96	0.2	19	19	0.16	10.68
3	CBMH#3	CBMH#4	94	190	0.2	19	38	0.59	11.27
4	CBMH#4	CBMH#7	711	2073	0.84	597	1702	0.35	11.62
5	CB#5	CBMH#6	669	669	0.86	575	575	0.48	10.48
6	CBMH#6	CBMH#7	652	1321	0.9	587	1162	0.67	12.28
7	CBMH#7	CBMH#9	693	4087	0.85	589	3453	0.26	10.26
8	CB#8	CBMH#9	523	523	0.36	188	188	0.30	10.57
9	CBMH#9	CBMH#10	533	5143	0.77	410	4052	0.30	12.59
10	CBMH#10	CBMH#11	354	5497	0.92	326	4377	0.08	10.08
11	CBMH#11	CBMH#12	491	5988	0.2	98	4476	0.54	10.62
12	CBMH#12	CBMH#13	360	6348	0.88	317	4792	0.43	13.02
13	CBMH#13	CBMH#14	463	6811	0.2	93	4885	0.24	13.27
Pipe	From	To	Rainfall Rate	Actual Flow	Pipe Diameter	Grade %	Capacity L/s	Velocity m/s	Length m
1	CB#1	CBMH#4	101.52	30.1	250	1.00	59.467529	1.21	37.80
2	CB#2	CBMH#3	100.73	0.5	250	3.00	103.00078	2.10	20.10
3	CBMH#3	CBMH#4	97.93	1.0	250	0.50	42.049893	0.86	30.40
4	CBMH#4	CBMH#7	96.36	75.6	300	0.75	83.745313	1.18	24.60
5	CB#5	CBMH#6	101.74	16.3	250	1.00	59.467529	1.21	34.70
6	CBMH#6	CBMH#7	93.50	30.2	250	0.50	42.049893	0.86	34.30
7	CBMH#7	CBMH#9	102.83	98.6	375	0.50	123.97713	1.12	17.60
8	CB#8	CBMH#9	101.30	5.3	250	2.00	84.099786	1.71	31.30
9	CBMH#9	CBMH#10	92.25	103.8	375	0.50	123.97713	1.12	20.50
10	CBMH#10	CBMH#11	103.75	126.1	375	0.55	130.02831	1.18	6.00
11	CBMH#11	CBMH#12	101.03	125.6	375	0.55	130.02831	1.18	37.80
12	CBMH#12	CBMH#13	90.54	120.5	375	0.55	130.02831	1.18	30.60
13	CBMH#13	CBMH#14	89.61	121.6	375	0.55	130.02831	1.18	17.20

APPENDIX C – Storage Calculations

1545 Woodoffe Avenue

**Controlled Area
5 yr Storm Post-Development Flow**

100 yr Peak Allow. Discharge	12.60 L/s
Discharge from 1st Orifice	1.30 L/s
Storage from 1st Orifice	103.88 m³
(based on 10 minute time of concentration)	

Elapsed time		Intensity		Acc Depth	C	Area	Flow	Storage Flow Due to 1st Orifice	Storm Duration Through 2nd Orifice	2nd Orifice Discharge	Storage flow	Storage volume	Total Storage Volume
(min)	(s)	(mm/hr)	(mm/s)	(mm)		(m ²)	(l/s)	(l/s)	(s)	(l/s)	(l/s)	(m ³)	(m ³)
0	0	0.00	0.0000	0.00	0.72	6811	0.00	0.00	0.00	0.00	0.00	0.00	103.88
5	300	141.18	0.0392	11.76	0.72	6811	192.31	191.01	-243.84	11.30	179.71	53.91	157.79
10	600	104.19	0.0289	20.45	0.72	6811	141.93	140.63	-138.67	11.30	129.33	77.60	181.48
15	900	83.56	0.0232	27.41	0.72	6811	113.82	112.52	-23.20	11.30	101.22	91.10	194.98
20	1200	70.25	0.0195	33.26	0.72	6811	95.70	94.40	99.53	11.30	83.10	99.72	203.60
25	1500	60.90	0.0169	38.34	0.72	6811	82.95	81.65	227.78	11.30	70.35	105.53	209.41
30	1800	53.93	0.0150	42.83	0.72	6811	73.46	72.16	360.42	11.30	60.86	109.55	213.43
35	2100	48.52	0.0135	46.88	0.72	6811	66.09	64.79	496.68	11.30	53.49	112.33	216.21
40	2400	44.18	0.0123	50.56	0.72	6811	60.19	58.89	635.98	11.30	47.59	114.21	218.09
45	2700	40.63	0.0113	53.94	0.72	6811	55.34	54.04	777.87	11.30	42.74	115.41	219.29
50	3000	37.65	0.0105	57.08	0.72	6811	51.29	49.99	922.03	11.30	38.69	116.07	219.95
55	3300	35.12	0.0098	60.01	0.72	6811	47.85	46.55	1068.18	11.30	35.25	116.31	220.19
60	3600	32.94	0.0092	62.75	0.72	6811	44.88	43.58	1216.09	11.30	32.28	116.19	220.07
65	3900	31.04	0.0086	65.34	0.72	6811	42.29	40.99	1365.58	11.30	29.69	115.78	219.66
70	4200	29.37	0.0082	67.79	0.72	6811	40.01	38.71	1516.49	11.30	27.41	115.12	219.00
75	4500	27.89	0.0077	70.11	0.72	6811	37.99	36.69	1668.68	11.30	25.39	114.25	218.13
80	4800	26.56	0.0074	72.33	0.72	6811	36.18	34.88	1822.03	11.30	23.58	113.20	217.08
85	5100	25.37	0.0070	74.44	0.72	6811	34.56	33.26	1976.45	11.30	21.96	111.98	215.86
90	5400	24.29	0.0067	76.46	0.72	6811	33.09	31.79	2131.85	11.30	20.49	110.62	214.50
95	5700	23.31	0.0065	78.41	0.72	6811	31.75	30.45	2288.14	11.30	19.15	109.14	213.02
100	6000	22.41	0.0062	80.27	0.72	6811	30.52	29.22	2445.26	11.30	17.92	107.54	211.42
105	6300	21.58	0.0060	82.07	0.72	6811	29.40	28.10	2603.14	11.30	16.80	105.84	209.72
110	6600	20.82	0.0058	83.81	0.72	6811	28.36	27.06	2761.73	11.30	15.76	104.04	207.92
115	6900	20.12	0.0056	85.48	0.72	6811	27.41	26.11	2920.98	11.30	14.81	102.17	206.05
120	7200	19.47	0.0054	87.11	0.72	6811	26.52	25.22	3080.83	11.30	13.92	100.21	204.09
125	7500	18.86	0.0052	88.68	0.72	6811	25.69	24.39	3241.25	11.30	13.09	98.19	202.07
130	7800	18.29	0.0051	90.20	0.72	6811	24.92	23.62	3402.20	11.30	12.32	96.10	199.98
135	8100	17.76	0.0049	91.68	0.72	6811	24.20	22.90	3563.64	11.30	11.60	93.96	197.84
140	8400	17.27	0.0048	93.12	0.72	6811	23.52	22.22	3725.54	11.30	10.92	91.75	195.63
145	8700	16.80	0.0047	94.52	0.72	6811	22.89	21.59	3887.87	11.30	10.29	89.50	193.38
150	9000	16.36	0.0045	95.89	0.72	6811	22.29	20.99	4050.60	11.30	9.69	87.20	191.08
155	9300	15.95	0.0044	97.22	0.72	6811	21.72	20.42	4213.70	11.30	9.12	84.85	188.73
160	9600	15.56	0.0043	98.51	0.72	6811	21.19	19.89	4377.15	11.30	8.59	82.46	186.34
165	9900	15.18	0.0042	99.78	0.72	6811	20.68	19.38	4540.93	11.30	8.08	80.03	183.91
170	10200	14.83	0.0041	101.01	0.72	6811	20.20	18.90	4705.02	11.30	7.60	77.57	181.45
175	10500	14.50	0.0040	102.22	0.72	6811	19.75	18.45	4869.39	11.30	7.15	75.07	178.95
180	10800	14.18	0.0039	103.40	0.72	6811	19.32	18.02	5034.03	11.30	6.72	72.53	176.41

Flow Calculations:
For 5m (300s) interval
t/600*A*C*I

1545 Woodoffe Avenue

**Controlled Area
4hr 25mm Chicago Storm**

100 yr Peak Allow. Discharge (based on 10 minute time of concentration)	1.30 L/s
--	----------

Elapsed time		Intensity		Acc Depth	C	Area	Flow	Discharge	Storage flow	Storage volume
(min)	(s)	(mm/hr)	(mm/s)	(mm)		(m ²)	(l/s)	(l/s)	(l/s)	(m ³)
0	0	0.00	0.0000	0.00	0.72	6811	0.00	0.00	0.00	0.00
10	600	2.07	0.0006	0.35	0.72	6811	2.82	1.30	1.52	0.91
20	1200	2.27	0.0006	0.72	0.72	6811	3.09	1.30	1.79	1.99
30	1800	2.52	0.0007	1.14	0.72	6811	3.43	1.30	2.13	3.27
40	2400	2.88	0.0008	1.62	0.72	6811	3.92	1.30	2.62	4.84
50	3000	3.38	0.0009	2.19	0.72	6811	4.60	1.30	3.30	6.82
60	3600	4.18	0.0012	2.88	0.72	6811	5.69	1.30	4.39	9.46
70	4200	5.70	0.0016	3.83	0.72	6811	7.76	1.30	6.46	13.34
80	4800	10.78	0.0030	5.63	0.72	6811	14.68	1.30	13.38	21.37
90	5400	50.21	0.0139	14.00	0.72	6811	68.40	1.30	67.10	61.63
100	6000	13.37	0.0037	16.23	0.72	6811	18.21	1.30	16.91	71.77
110	6600	8.29	0.0023	17.61	0.72	6811	11.29	1.30	9.99	77.77
120	7200	6.30	0.0018	18.66	0.72	6811	8.58	1.30	7.28	82.14
130	7800	5.19	0.0014	19.52	0.72	6811	7.07	1.30	5.77	85.60
140	8400	4.47	0.0012	20.27	0.72	6811	6.09	1.30	4.79	88.47
150	9000	3.95	0.0011	20.93	0.72	6811	5.38	1.30	4.08	90.92
160	9600	3.56	0.0010	21.52	0.72	6811	4.85	1.30	3.55	93.05
170	10200	3.25	0.0009	22.06	0.72	6811	4.43	1.30	3.13	94.93
180	10800	3.01	0.0008	22.56	0.72	6811	4.10	1.30	2.80	96.61
190	11400	2.80	0.0008	23.03	0.72	6811	3.81	1.30	2.51	98.12
200	12000	2.62	0.0007	23.47	0.72	6811	3.57	1.30	2.27	99.48
210	12600	2.48	0.0007	23.88	0.72	6811	3.38	1.30	2.08	100.73
220	13200	2.35	0.0007	24.27	0.72	6811	3.20	1.30	1.90	101.87
230	13800	2.23	0.0006	24.64	0.72	6811	3.04	1.30	1.74	102.91
240	14400	2.14	0.0006	25.00	0.72	6811	2.92	1.30	1.62	103.88

-peak storage

Flow Calculations: For 10m (600s) interval $t/600 * A * C * I$
--

1545 Woodoffe Avenue

**Controlled Area
100 yr Storm Post-Development Flow**

100 yr Peak Allow. Discharge	12.60 L/s
Discharge from 1st Orifice	1.30 L/s
Storage from 1st Orifice	103.88 m ³
(based on 10 minute time of concentration)	

Elapsed time		Intensity		Acc Depth	C	Area	Flow	Storage Flow Due to 1st Orifice	Storm Duration Through 2nd Orifice	2nd Orifice Discharge	Storage flow	Storage volume	Total Storage Volume
(min)	(s)	(mm/hr)	(mm/s)	(mm)		(m ²)	(l/s)	(l/s)	(s)	(l/s)	(l/s)	(m ³)	(m ³)
0	0	0.00	0.0000	0.00	0.8	6811	0.00	0.00	0.00	0.00	0.00	0.00	103.88
5	300	242.70	0.0674	20.23	0.8	6811	367.35	366.05	16.21	11.30	354.75	106.42	210.30
10	600	178.56	0.0496	35.11	0.8	6811	270.26	268.96	213.77	11.30	257.66	154.60	258.48
15	900	142.89	0.0397	47.01	0.8	6811	216.28	214.98	416.79	11.30	203.68	183.31	287.19
20	1200	119.95	0.0333	57.01	0.8	6811	181.55	180.25	623.69	11.30	168.95	202.74	306.62
25	1500	103.85	0.0288	65.66	0.8	6811	157.18	155.88	833.58	11.30	144.58	216.87	320.75
30	1800	91.87	0.0255	73.32	0.8	6811	139.05	137.75	1045.87	11.30	126.45	227.61	331.49
35	2100	82.58	0.0229	80.20	0.8	6811	124.99	123.69	1260.14	11.30	112.39	236.01	339.89
40	2400	75.15	0.0209	86.46	0.8	6811	113.74	112.44	1476.10	11.30	101.14	242.73	346.61
45	2700	69.05	0.0192	92.22	0.8	6811	104.51	103.21	1693.52	11.30	91.91	248.16	352.04
50	3000	63.95	0.0178	97.55	0.8	6811	96.80	95.50	1912.23	11.30	84.20	252.59	356.47
55	3300	59.62	0.0166	102.51	0.8	6811	90.24	88.94	2132.07	11.30	77.64	256.22	360.10
60	3600	55.89	0.0155	107.17	0.8	6811	84.60	83.30	2352.94	11.30	72.00	259.20	363.08
65	3900	52.65	0.0146	111.56	0.8	6811	79.68	78.38	2574.72	11.30	67.08	261.63	365.51
70	4200	49.79	0.0138	115.71	0.8	6811	75.36	74.06	2797.34	11.30	62.76	263.59	367.47
75	4500	47.26	0.0131	119.65	0.8	6811	71.52	70.22	3020.73	11.30	58.92	265.16	369.04
80	4800	44.99	0.0125	123.40	0.8	6811	68.10	66.80	3244.82	11.30	55.50	266.38	370.26
85	5100	42.95	0.0119	126.98	0.8	6811	65.01	63.71	3469.57	11.30	52.41	267.31	371.19
90	5400	41.11	0.0114	130.40	0.8	6811	62.22	60.92	3694.92	11.30	49.62	267.97	371.85
95	5700	39.43	0.0110	133.69	0.8	6811	59.69	58.39	3920.83	11.30	47.09	268.39	372.27
100	6000	37.90	0.0105	136.85	0.8	6811	57.37	56.07	4147.26	11.30	44.77	268.61	372.49
105	6300	36.50	0.0101	139.89	0.8	6811	55.24	53.94	4374.19	11.30	42.64	268.64	372.52
110	6600	35.20	0.0098	142.82	0.8	6811	53.28	51.98	4601.57	11.30	40.68	268.49	372.37
115	6900	34.01	0.0094	145.65	0.8	6811	51.47	50.17	4829.39	11.30	38.87	268.20	372.08
120	7200	32.89	0.0091	148.40	0.8	6811	49.79	48.49	5057.62	11.30	37.19	267.76	371.64
125	7500	31.86	0.0089	151.05	0.8	6811	48.22	46.92	5286.24	11.30	35.62	267.19	371.07
130	7800	30.90	0.0086	153.63	0.8	6811	46.77	45.47	5515.22	11.30	34.17	266.50	370.38
135	8100	30.00	0.0083	156.13	0.8	6811	45.40	44.10	5744.55	11.30	32.80	265.70	369.58
140	8400	29.15	0.0081	158.56	0.8	6811	44.12	42.82	5974.21	11.30	31.52	264.79	368.67
145	8700	28.36	0.0079	160.92	0.8	6811	42.92	41.62	6204.18	11.30	30.32	263.80	367.68
150	9000	27.61	0.0077	163.22	0.8	6811	41.79	40.49	6434.45	11.30	29.19	262.71	366.59
155	9300	26.91	0.0075	165.46	0.8	6811	40.72	39.42	6665.00	11.30	28.12	261.55	365.43
160	9600	26.24	0.0073	167.65	0.8	6811	39.71	38.41	6895.83	11.30	27.11	260.30	364.18
165	9900	25.61	0.0071	169.78	0.8	6811	38.76	37.46	7126.91	11.30	26.16	258.98	362.86
170	10200	25.01	0.0069	171.87	0.8	6811	37.85	36.55	7358.24	11.30	25.25	257.60	361.48
175	10500	24.44	0.0068	173.90	0.8	6811	37.00	35.70	7589.81	11.30	24.40	256.15	360.03
180	10800	23.90	0.0066	175.90	0.8	6811	36.18	34.88	7821.60	11.30	23.58	254.64	358.52

Flow Calculations:
For 5m (300s) interval
t/600*A*C*I

APPENDIX D – Inlet Control Device Specifications

CSO/STORMWATER MANAGEMENT



HYDROVEX[®] VHV / SVHV
Vertical Vortex Flow Regulator

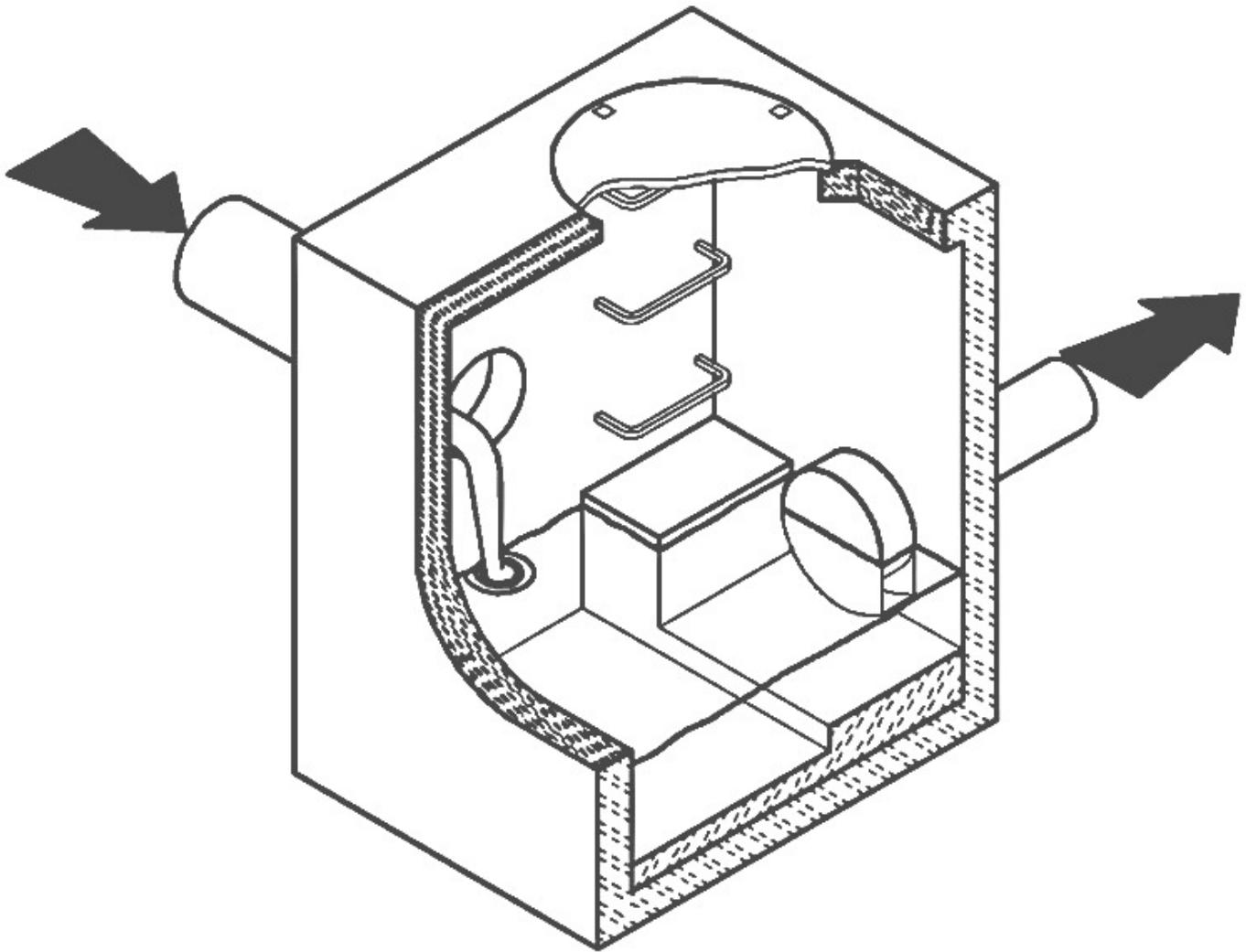

JOHN MEUNIER

HYDROVEX® VHV / SVHV VERTICAL VORTEX FLOW REGULATOR

APPLICATIONS

One of the major problems of urban wet weather flow management is the runoff generated after a heavy rainfall. During a storm event, uncontrolled flows may overload the drainage system and cause flooding. Sewer pipe wear and network deterioration are increased dramatically as a result of increased flow velocities. In a combined sewer system, the wastewater treatment plant will experience a significant increase in flows during storms, thereby losing its treatment efficiency.

A simple means of managing excessive water runoff is to control excessive flows at their point of origin, the manhole. **John Meunier Inc.** manufactures the **HYDROVEX® VHV / SVHV** line of vortex flow regulators for point source control of stormwater flows in sewer networks, as well as manholes, catch basins and other retention structures.

The **HYDROVEX® VHV / SVHV** design is based on the fluid mechanics principle of the forced vortex. The discharge is controlled by an air-filled vortex which reduces the effective water passage area without physically reducing orifice size. This effect grants precise flow regulation without the use of moving parts or electricity, thus minimizing maintenance. Although the concept is quite simple, over 12 years of research and testing have been invested in our vortex technology design in order to optimize its performance.

The **HYDROVEX® VHV / SVHV** Vertical Vortex Flow Regulators (refer to **Figure 1**) are manufactured entirely of stainless steel, and consist of a hollow body (1) (in which flow control takes place) and an outlet orifice (7). Two rubber "O" rings (3) seal and retain the unit inside the outlet pipe. Two stainless steel retaining rings (4) are welded on the outlet sleeve to ensure that there is no shifting of the "O" rings during installation and operation.

1. BODY
2. SLEEVE
3. O-RING
4. RETAINING RINGS
(SQUARE BAR)
5. ANCHOR PLATE
6. INLET
7. OUTLET ORIFICE

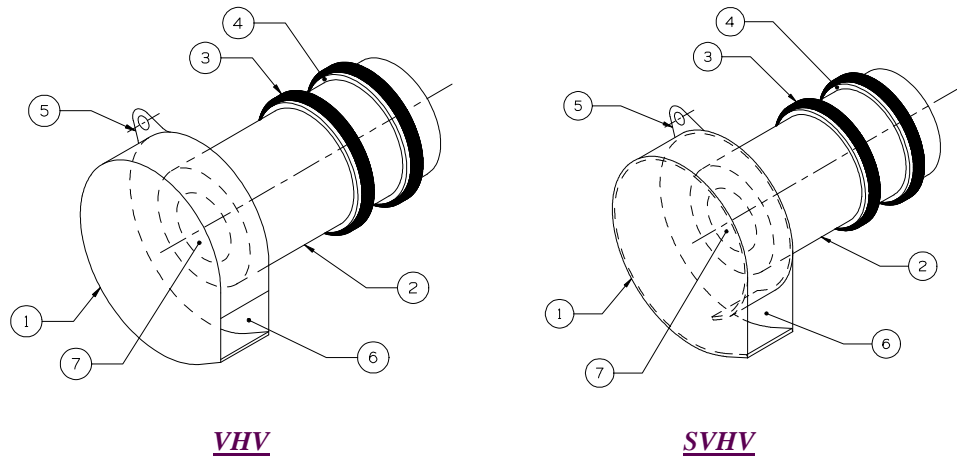

FIGURE 1: HYDROVEX® VHV-SVHV VERTICAL VORTEX FLOW REGULATORS

ADVANTAGES

- As a result of the air-filled vortex, a **HYDROVEX® VHV / SVHV** flow regulator will typically have an opening 4 to 6 times larger than an orifice plate. Larger opening sizes decrease the chance of blockage caused by sediments and debris found in stormwater flows. **Figure 2** shows the discharge curve of a vortex regulator compared to an equally sized orifice plate. One can see that for the same height of water and same opening size, the vortex regulator controls a flow approximately four times smaller than the orifice plate.
- Having no moving parts, they require minimal maintenance.
- Submerged inlet for floatables control.
- The **HYDROVEX® VHV / SVHV** line of flow regulators are manufactured entirely of stainless steel, making them durable and corrosion resistant.
- Installation of the **HYDROVEX® VHV / SVHV** flow regulators is quick and straightforward and is performed after all civil works are completed.
- Installation requires no assembly, special tools or equipment and may be carried out by any contractor.

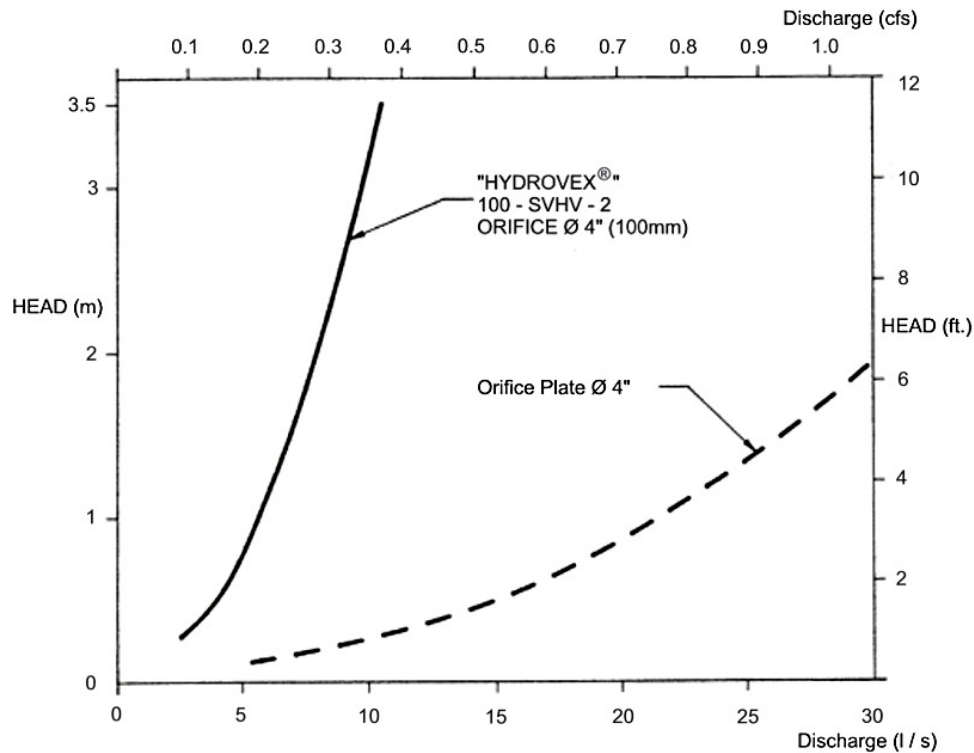

FIGURE 2: DISCHARGE CURVE SHOWING A HYDROVEX® FLOW REGULATOR VS AN ORIFICE PLATE

SELECTION

Selecting a **VHV** or **SVHV** regulator is easily achieved using the selection chart found at the end of this brochure (refer to **Figure 3**). Each selection is made using the maximum allowable discharge rate and the maximum allowable water pressure (head) retained upstream from the regulator. The area in which the design point falls will designate the required VHV/SVHV model. The maximum design head is calculated as the difference between the maximum upstream water level and the invert of the outlet pipe. All selections should be verified by a John Meunier Inc. representative prior to fabrication.

Example:

- ✓ Maximum discharge 6 L/s (0.2 cfs)**
- ✓ Maximum design head 2m (6.56 ft.)
- ✓ Using **Figure 3** model required is a **75 VHV-1**

** It is important to verify the capacity of the manhole/catch basin outlet pipe. Should the outlet pipe be >80% full at design flow, the use of an air vent is required.

INSTALLATION REQUIREMENTS

HYDROVEX® VHV / SVHV flow regulators can be installed in circular or square manholes. **Figure 4** lists the minimum dimensions required for each regulator model. *It is imperative to respect the minimum clearances shown to ensure ease of installation and proper functioning of the regulator.*

SPECIFICATIONS

In order to specify a **HYDROVEX® VHV/SVHV** flow regulator, the following parameters must be clearly indicated:

- The model number (ex: 75-VHV-1)
- The diameter and type of outlet pipe (ex: \varnothing 6", SDR 35)
- The maximum discharge rate (ex: 6.0 L/s [0.21 CFS])
- The maximum upstream head (ex: 2.0 m [6.56 ft]) *
- The manhole diameter (ex: \varnothing 900 mm [\varnothing 36"])
- The minimum clearance "H" (ex: 150 mm [6 in]) as indicated in **Figure 4**
- The material type (ex: 304 stainless steel, standard)

* *Upstream head is defined as the difference in elevation between the maximum upstream water level and the invert of the outlet pipe where the **HYDROVEX®** flow regulator is to be installed.*

PLEASE NOTE THAT WHEN REQUESTING A PROPOSAL, WE SIMPLY REQUIRE THAT YOU PROVIDE US WITH THE FOLLOWING INFORMATION:

- *project design flow rate*
- *pressure head*
- *chamber's outlet pipe diameter and type*



*Typical **HYDROVEX®** VHV model*

OPTIONS



VHV-1-O
(extended inlet for odor control)



FV-VHV
(mounted on sliding plate for emergency bypass)



VHV with Gooseneck assembly
(manhole without clearance below regulator)

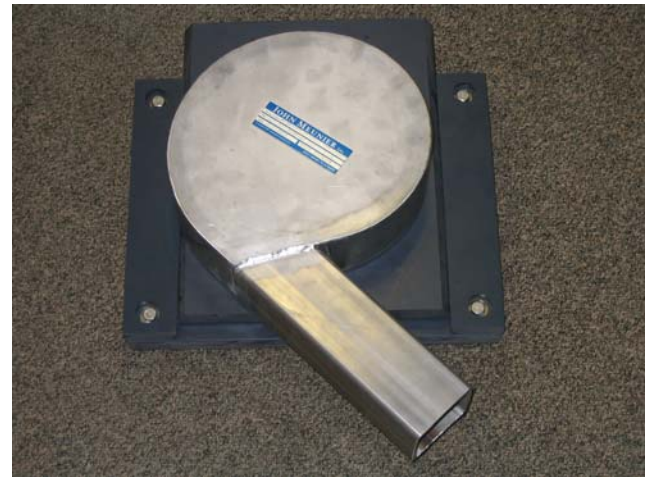

FV-VHV-O
(sliding plate with extended inlet)



VHV with upstream air vent
(applications where outlet pipe is > 80% full at peak flow)



VHV/SVHV Vortex Flow Regulator

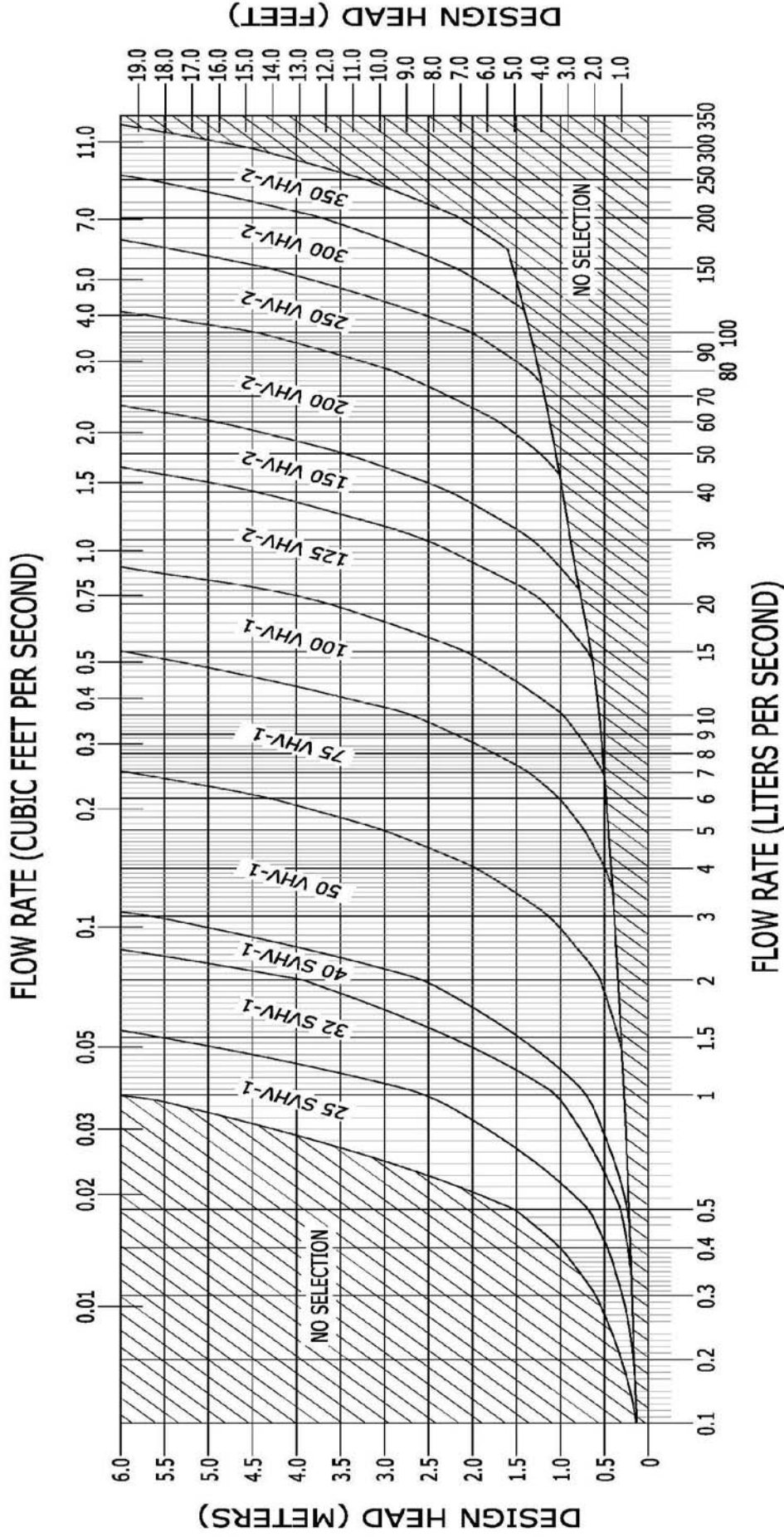

FIGURE 3

JOHN MEUNIER

**TYPICAL INSTALLATION OF A VORTEX FLOW REGULATOR IN
A CIRCULAR OR SQUARE/RECTANGULAR MANHOLE
FIGURE 4**

Model	Regulator Diameter A (mm) [in]	<u>CIRCULAR</u>	<u>SQUARE</u>	Minimum Outlet Pipe Diameter C (mm) [in]	Minimum Clearance H (mm) [in]
		Minimum Manhole Diameter B (mm) [in]	Minimum Chamber Width B (mm) [in]		
25 SVHV-1	125 [5]	600 [24]	600 [24]	150 [6]	150 [6]
32 SVHV-1	150 [6]	600 [24]	600 [24]	150 [6]	150 [6]
40 SVHV-1	200 [8]	600 [24]	600 [24]	150 [6]	150 [6]
50 VHV-1	150 [6]	600 [24]	600 [24]	150 [6]	150 [6]
75 VHV-1	250 [10]	600 [24]	600 [24]	150 [6]	150 [6]
100 VHV-1	325 [13]	900 [36]	600 [24]	150 [6]	200 [8]
125 VHV-2	275 [11]	900 [36]	600 [24]	150 [6]	200 [8]
150 VHV-2	350 [14]	900 [36]	600 [24]	150 [6]	225 [9]
200 VHV-2	450 [18]	1200 [48]	900 [36]	200 [8]	300 [12]
250 VHV-2	575 [23]	1200 [48]	900 [36]	250 [10]	350 [14]
300VHV-2	675 [27]	1600 [64]	1200 [48]	250 [10]	400 [16]
350VHV-2	800 [32]	1800 [72]	1200 [48]	300 [12]	500 [20]

Circular Manhole

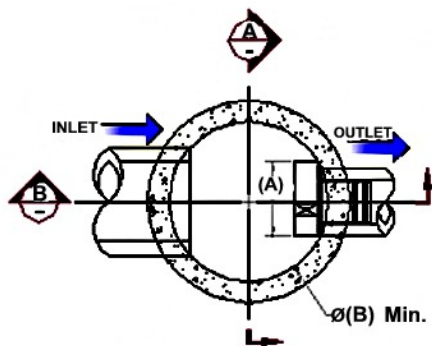

CIRCULAR WELL

Square / Rectangular Manhole

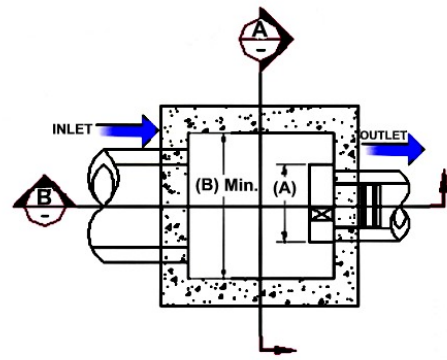

SQUARE / RECTANGULAR WELL

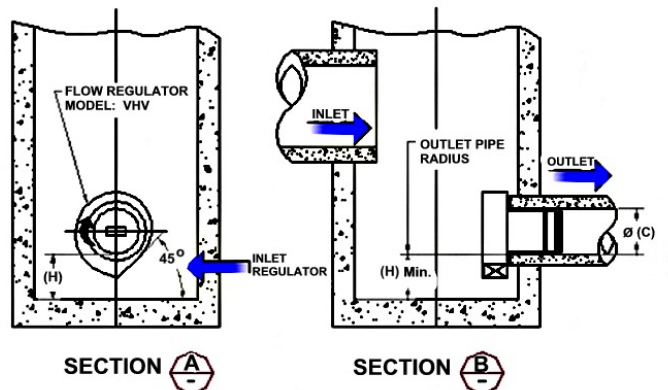
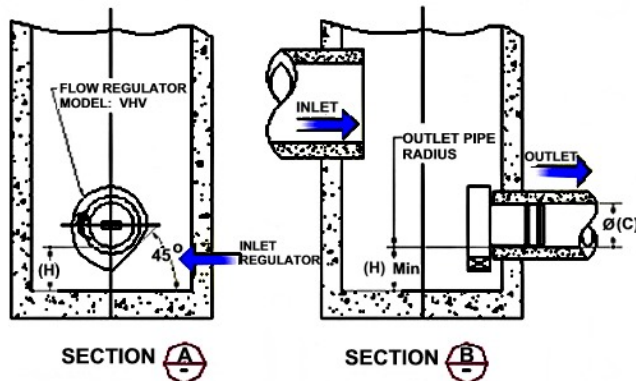

NOTE: *In the case of a square manhole, the outlet pipe must be centered on the wall to ensure that there is enough clearance for installation of the regulator.*

INSTALLATION

The installation of a **HYDROVEX**[®] regulator may begin once the manhole and piping are in place. Installation consists of simply sliding the regulator into the outlet pipe of the manhole and securing it to the wall with an anchor (supplied). **John Meunier Inc.** recommends applying a lubricant on the inner surface of the outlet pipe, in order to facilitate the insertion and the manipulation of the flow controller.

MAINTENANCE

HYDROVEX[®] regulators are designed and manufactured to minimize maintenance requirements. We recommend a periodic visual inspection every 3-6 months (depending on local flow and sediment conditions) in order to ensure that neither the inlet nor the outlet has become blocked with debris. The manhole housing the vortex regulator should be inspected and cleaned with a vacuum truck periodically, especially after major storm events.

GUARANTY

The **HYDROVEX**[®] line of **VHV / SVHV** regulators are guaranteed against both design and manufacturing defects for a period of 5 years after sale. Should a flow regulator be found to be defective within the guarantee period, **John Meunier Inc.** will modify or replace the defective unit.

John Meunier Inc.

ISO 9001 : 2008

Head Office

4105 Sartelon
Saint-Laurent (Quebec) Canada H4S 2B3
Tel.: 514-334-7230 www.johnmeunier.com
Fax: 514-334-5070 cso@johnmeunier.com

Ontario Office

2000 Argenta Road, Plaza 4, Unit 430
Mississauga (Ontario) Canada L5N 1W1
Tel.: 905-286-4846 www.johnmeunier.com
Fax: 905-286-0488 ontario@johnmeunier.com

USA Office

2209 Menlo Avenue
Glenside, PA USA 19038
Tel.: 412-417-6614 www.johnmeunier.com
Fax: 215-885-4741 asteele@johnmeunier.com



APPENDIX E – Atlantis Matrix Storage Tank Specifications



US 888-676-6041
CAN 877-917-1571

Atlantis Matrix Tank

1. Product Description

The Atlantis® Matrix Tank is a modular underground tank system developed through years of research and development and provides a highly efficient method to manage storm water. This subsurface system can be constructed to hold any volume required being limited only by the area available. The Atlantis tanks are assembled from small plates and large plates. Depending on loading and design, the quantity of small plates can be increased to up to seven for each module to handle higher loading. The subsurface nature of the Atlantis Matrix Tank frees up space for surface landscaping, driveway or parking lot use while meeting the storm water retention and detention requirements of your local municipality. It is ideal for the construction of infiltration tanks, water re-use tanks, and sub surface channels. Sediment can be removed by pretreating stormwater and/or by installing maintenance ports or a lower tank (forebay) with a maintenance port.

2. Technical Data

Materials information is on page 2.

3. Installation

Installation of Atlantis tanks must be in accordance with the latest installation manual which is available from Layfield. The installation begins with site excavation, base preparation and compaction to 95% of standard proctor. The base is then covered with a layer of angular stone and sand to a depth of 100 mm. A nonwoven geotextile and /or geomembrane are installed on the base. The Atlantis tank modules are assembled to the desired configuration and placed within the excavation. Piping is installed and then the geotextile and/or geomembrane are wrapped around the installed modules. Place clean sand backfill around the sides of the tanks in 150 mm lifts and compact to 95% and then place sand above the tanks and compact. Careful attention should be paid to the manufacturers recommended construction and compaction equipment that should be used when installing this system. This can be found in the installation manual. An RX 1200 geogrid is installed at 300 mm over the structure and extending

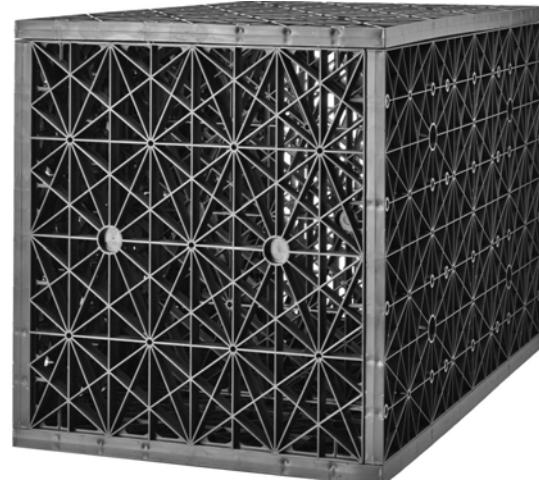

4. Availability and Cost

Available from Layfield or distributors. Call 425-254-1075 Pacific time 877-917-1571 Mountain time, or 905-761-9123 Eastern time

5. Manufactured For

Layfield USA Corp.
Layfield Canada Ltd.

6. Warranty

Products sold will meet Layfield's published specifications at time of sale. Full warranty details are available from Layfield.

7. Maintenance

Storm storage systems should be inspected on a regular schedule and after every major precipitation event. Inspect sediment traps and filters for accumulated debris and/or sediment. Inspect and schedule the removal of accumulated sediment to suit your site conditions but at least annually.

8. Filing Systems

<https://www.layfieldgroup.com/Geosynthetics/Storm-Water-Control-Products/Atlantis-Matrix-Tank.aspx>

beyond the edges by 900 mm or as required by the plans. Refer to and follow project specific drawings and specifications. Once the construction is complete it should be cordoned off and protected from heavy construction vehicle traffic.

9.

15 December 2011	Atlantis Matrix Tank - Metric Values					
	Mini	Single	Double	Triple	Quad	Penta
Height (mm)	240	450	880	1310	1740	2170
Length (mm)	685	685	685	685	685	685
Width (mm)	408	408	408	408	408	408
Tank Volume (m ³)	0.07	0.13	0.25	0.37	0.49	0.61
Water Storage Volume (liters)	64	120	234	348	462	576
Number of Plates (large / small)	2 / 4 / 2	4 / 4	7 / 8	10 / 12	13 / 16	16 / 20
Tank Weight (kg)	4	6.5	12	17.5	24	41
Void Space	Approx. 95 to 90 % (4 to 7 plate tanks)					
Material	85% recycled Polypropylene + 15% Atlantis proprietary selected materials					
Vertical Compressive Strength						
	4 Plate tank		5 Plate tank		7 Plate tank	
Ultimate Strength (Tonnes per m ² / PSI)	22 / 31.3		24 / 34.1		31 / 44.1	
Design Strength (Tonnes per m ² / PSI)	11 / 15.6		12 / 17.0		15.5 / 22.0	
<p>NOTES:</p> <p>The design strength above is based on the manufacturers recommendation for a minimum factor of safety of 2 on ultimate compressive strength of material due to variation in recycled plastic batches. Additional factors of safety may be applicable.</p> <p>Installation of Atlantis tanks must be in accordance with the latest installation manual including specific compaction and equipment requirements.</p> <p><i>These products are only available in Canada and the Western US. Please contact your local representative in the US for alternate materials.</i></p>						



www.LayfieldConstructionProducts.com
customerservice@layfieldconstructionproducts.com

APPENDIX F – Site Servicing Checklist

Development Servicing Study Checklist

4.1 General	Addressed (Y/N/NA)	Comments
Executive Summary (for larger reports only).	N/A	
Date and revision number of the report.	Y	
Location map and plan showing municipal address, boundary, and layout of the proposed development.	Y	
Plan showing the site and location of all existing services.	Y	
Development statistics, land use, density, adherence to zoning and official plan, and reference to applicable subwatershed and watershed plans that provide context to which individual developments must adhere.	N/A	
Summary of Pre-consultation Meetings with City and other approval agencies.	N/A	
Reference and confirm conformance to higher level studies and reports (Master Servicing Studies, Environmental Assessments, Community Design Plans), or in the case where it is not in conformance, the proponent must provide justification and develop a defensible design criteria.	Y	Stormwater Management Guidelines for the Pinecrest Creek / Westboro Area
Statement of objectives and servicing criteria.	Y	
Identification of existing and proposed infrastructure available in the immediate area.	Y	
Identification of Environmental Significant Areas, watercourses and Municipal Drains potentially impacted by the proposed development (Reference can be made to the Natural Heritage Studies, if available).	N/A	
Concept level master grading plan to confirm existing and proposed grades in the development. This is required to confirm that the feasibility of proposed stormwater management and drainage, soil removal and fill constraints, and potential impacts to neighbouring properties. This is also required to confirm that the proposed grading will not impede existing major system flow paths.	Y	
Identification of potential impacts of proposed piped services on private services (such as wells and septic fields on adjacent lands) and mitigation required to address potential impacts.	N/A	
Proposed phasing of the development, if applicable.	N/A	

Development Servicing Study Checklist

4.1 General	Addressed (Y/N/NA)	Comments
Reference to geotechnical studies and recommendations concerning servicing.	Y	
All preliminary and formal site plan submissions should have the following information: -Metric scale -North arrow (including construction North) -Key plan -Name and contact information of applicant and property owner -Property limits including bearings and dimensions -Existing and proposed structures and parking areas -Easements, road widening and rights-of-way -Adjacent street names	Y	

Development Servicing Study Checklist

4.2 Development Servicing Report: Water	Addressed (Y/N/NA)	Comments
Confirm consistency with Master Servicing Study, if available	N/A	
Availability of public infrastructure to service proposed development	Y	
Identification of system constraints	N	
Identify boundary conditions	N	
Confirmation of adequate domestic supply and pressure	N	
Confirmation of adequate fire flow protection and confirmation that fire flow is calculated as per the Fire Underwriter's Survey. Output should show available fire flow at locations throughout the development.	N	
Provide a check of high pressures. If pressure is found to be high, an assessment is required to confirm the application of pressure reducing valves.	N	
Definition of phasing constraints. Hydraulic modeling is required to confirm servicing for all defined phases of the project including the ultimate design	N	
Address reliability requirements such as appropriate location of shut-off valves	Y	
Check on the necessity of a pressure zone boundary modification.	N	
Reference to water supply analysis to show that major infrastructure is capable of delivering sufficient water for the proposed land use. This includes data that shows that the expected demands under average day, peak hour and fire flow conditions provide water within the required pressure range.	N	
Description of the proposed water distribution network, including locations of proposed connections to the existing system, provisions for necessary looping, and appurtenances (valves, pressure reducing valves, valve chambers, and fire hydrants) including special metering	Y	

Development Servicing Study Checklist

4.2 Development Servicing Report: Water	Addressed (Y/N/NA)	Comments
Description of off-site required feeder mains, booster pumping stations, and other water infrastructure that will be ultimately required to service the proposed development, including financing, interim facilities, and timing of implementation	N/A	
Confirmation that water demands are calculated based on the City of Ottawa Design Guidelines.	Y	
Provision of a model schematic showing boundary conditions locations, streets, parcels, and building locations for reference.	Y	

Development Servicing Study Checklist

4.3 Development Servicing Report: Wastewater	Addressed (Y/N/NA)	Comments
Summary of proposed design criteria (Note: Wet-weather flow criteria should not deviate from the City of Ottawa Sewer Design Guidelines. Monitored flow data from relatively new infrastructure cannot be used to justify capacity requirements for proposed infrastructure).	N/A	
Confirm consistency with Master Servicing Study and/or justifications for deviations.	N/A	
Consideration of local conditions that may contribute to extraneous flows that are higher than the recommended flows in the guidelines. This includes groundwater and soil conditions, and age and condition of sewers.	Y	
Description of existing sanitary sewer available for discharge of wastewater from proposed development.	Y	
Verify available capacity in downstream sanitary sewer and/or identification of upgrades necessary to service the proposed development. (Reference can be made to previously completed Master Servicing Study if applicable).	Y	
Calculations related to dry-weather and wet-weather flow rates from the development in standard MOE sanitary sewer design table (Appendix 'C') format.	N/A	
Description of proposed sewer network including sewers, pumping stations, and forcemains.	N/A	
Discussion of previously identified environmental constraints and impact on servicing (environmental constraints are related to limitations imposed on the development in order to preserve the physical condition of watercourses, vegetation, soil cover, and as well as protecting against water quantity and quality).	N/A	
Pumping stations: impacts of proposed development on existing pumping stations or requirements for new pumping station to service development.	N/A	
Forcemain capacity in terms of operational redundancy, surge pressure and maximum flow velocity.	N/A	

Development Servicing Study Checklist

4.3 Development Servicing Report: Wastewater	Addressed (Y/N/NA)	Comments
Identification and implementation of the emergency overflow from sanitary pumping stations in relation to the hydraulic grade line to protect against basement flooding.	N/A	
Special considerations such as contamination, corrosive environment etc.	N/A	

Development Servicing Study Checklist

4.4 Development Servicing Report: Stormwater Checklist	Addressed (Y/N/NA)	Comments
Description of drainage outlets and downstream constraints including legality of outlets (i.e. Municipal drain, right-of-way, watercourse, or private property).	Y	
Analysis of available capacity in existing public infrastructure.	Y	
A drawing showing the subject lands, its surroundings, the receiving watercourse, existing drainage patterns and proposed drainage pattern.	Y	
Water quantity control objective (e.g. Controlling post-development peak flows to pre-development level for storm events ranging from the 2 or 5 year event (dependent on the receiving sewer design) to 100 year return period); if other objectives are being applied, a rationale must be included with reference to hydrologic analysis of the potentially affected subwatersheds, taking into account long-term cumulative effects.	Y	
Water Quality control objective (basic, normal or enhanced level of protection based on the sensitivities of the receiving watercourse) and storage requirements.	Y	
Description of the stormwater management concept with facility locations and descriptions with references and supporting information.	Y	
Set-back from private sewage disposal systems.	N/A	
Watercourse and hazard lands setbacks.	N/A	
Record of pre-consultation with the Ontario Ministry of Environment and the Conservation Authority that has jurisdiction on the affected watershed.	N/A	
Confirm consistency with sub-watershed and Master Servicing Study, if applicable study exists.	Y	
Storage requirements (complete with calculations) and conveyance capacity for minor events (1:5 year return period) and major events (1:100 year return period).	Y	

Development Servicing Study Checklist

4.4 Development Servicing Report: Stormwater Checklist	Addressed (Y/N/NA)	Comments
Identification of watercourses within the proposed development and how watercourses will be protected, or, if necessary altered by the proposed development with applicable approvals.	N/A	
Calculate pre and post development peak flow rates including a description of existing site conditions and proposed impervious areas and drainage catchments in comparison to existing conditions.	Y	
Any proposed diversion of drainage catchment areas from one outlet to another	N/A	
Proposed minor and major systems including locations and sizes of stormwater trunk sewers, and stormwater management facilities.	Y	
If quantity control is not proposed, demonstration that downstream system has adequate capacity for the post-development flows up to and including the 100-year return period storm event.	N/A	
Identification of potential impacts to receiving watercourses.	N/A	
Identification of municipal drains and related approval requirements	N/A	
Descriptions of how the conveyance and storage capacity will be achieved for the development.	Y	
100 year flood levels and major flow routing to protect proposed development from flooding for establishing minimum building elevations (MBE) and overall grading.	Y	
Including of hydraulic analysis including hydraulic grade line elevations.	N/A	

Development Servicing Study Checklist

4.4 Development Servicing Report: Stormwater Checklist	Addressed (Y/N/NA)	Comments
Description of approach to erosion and sediment control during construction for the protection of receiving watercourse or drainage corridors.	Y	
Identification of floodplains - proponent to obtain relevant floodplain information from the appropriate Conservation Authority. The proponent may be required to delineate floodplain elevations to the satisfaction of the Conservation Authority if such information is not available or if the information does not match current conditions.	N/A	
Identification of fill constraints related to floodplain and geotechnical investigation.	N/A	

Development Servicing Study Checklist

4.5 Approval and Permit Requirements: Checklist	Addressed (Y/N/NA)	Comments
<p>Conservation Authority as the designated approval agency for modification of floodplain, potential impact on fish habitat, proposed works in or adjacent to a watercourse, cut/fill permits and Approval under Lakes and Rivers Improvement Act. The Conservation Authority is not the approval authority for the Lakes and Rivers Improvement Act. Where there are Conservation Authority regulations in place, approval under the Lakes and Rivers Improvement Act is not required, except in cases of dams as defined in the Act.</p>	N/A	
<p>Application for Certificate of Approval (CofA) under the Ontario Water Resources Act.</p>	N/A	
<p>Changes to Municipal Drains</p>	N/A	
<p>Other permits (National Capital Commission, Parks Canada, Public Works and Government Services Canada, Ministry of Transportation etc.)</p>	N/A	

Development Servicing Study Checklist

	Addressed (Y/N/NA)	Comments
4.6 Conclusion Checklist		
Clearly stated conclusions and recommendations	Y	
Comments received from review agencies including the City of Ottawa and information on how the comments were addressed. Final sign-off from the responsible reviewing agency.	N/A	
All draft and final reports shall be signed and stamped by a professional Engineer registered in Ontario	Y	