

1 SHRUB PLANTING N.T.S.
L-02

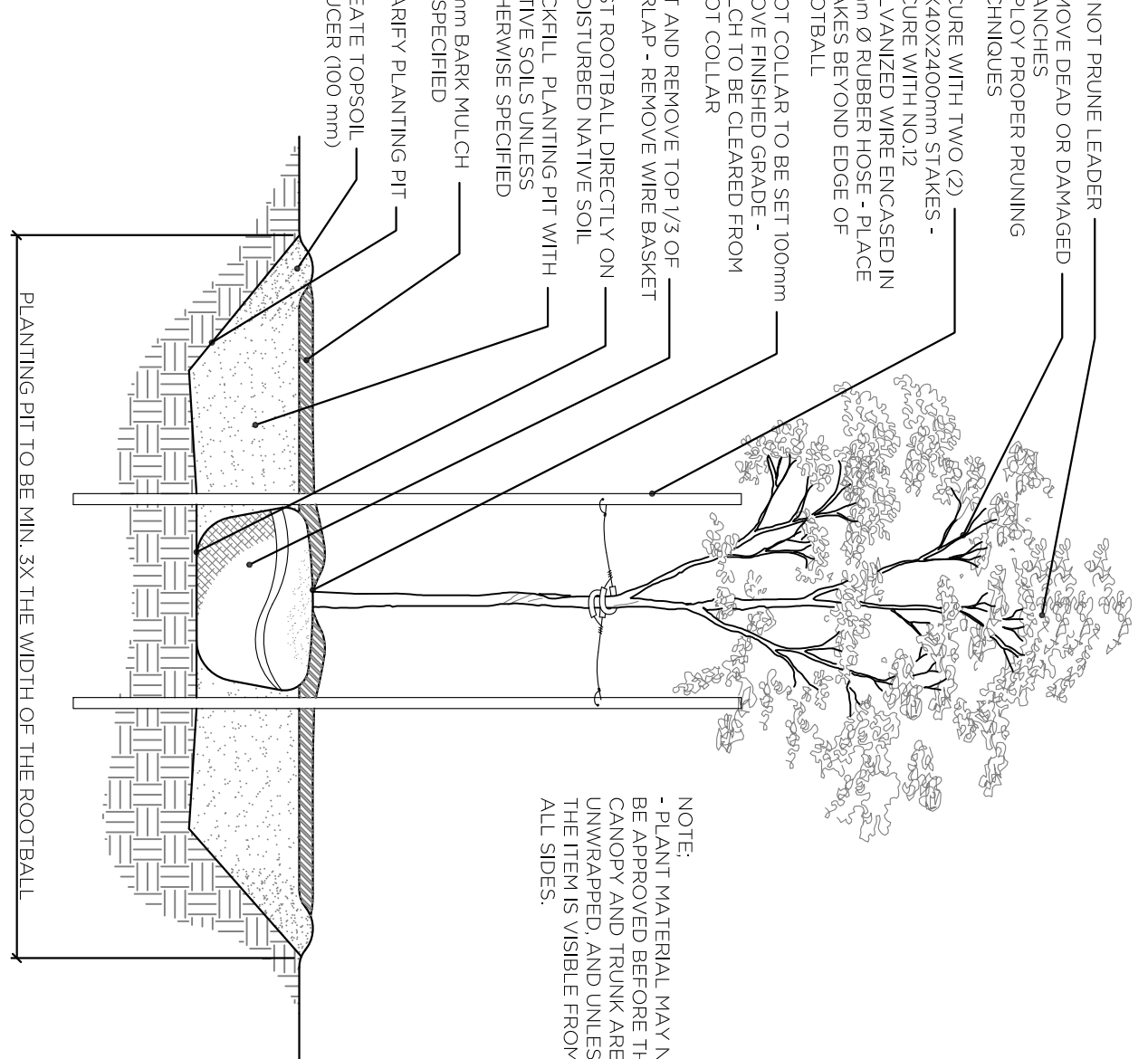

2 TREE PLANTING N.T.S.
L-02

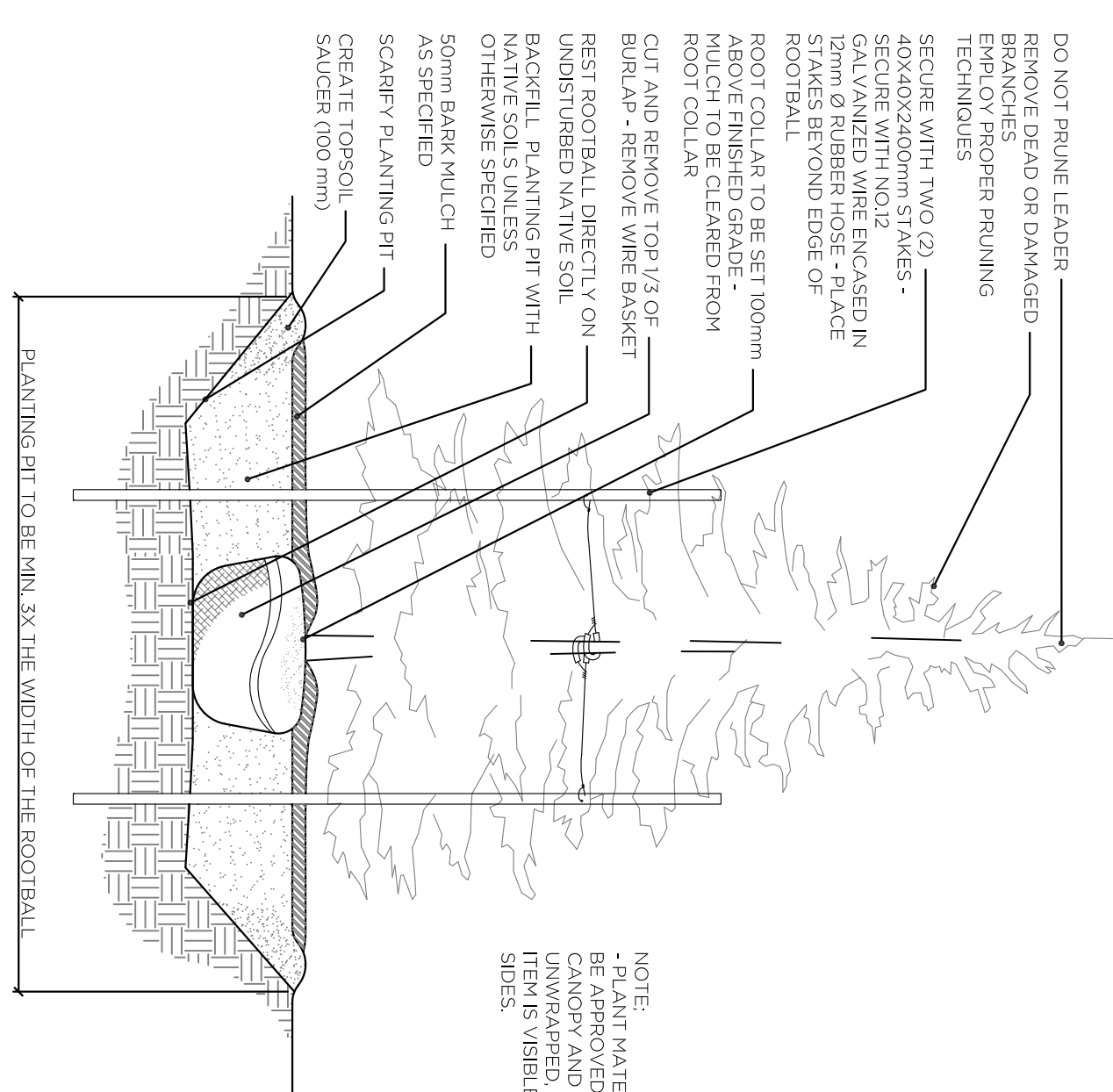

2 TREE PLANTING N.T.S.
L-02

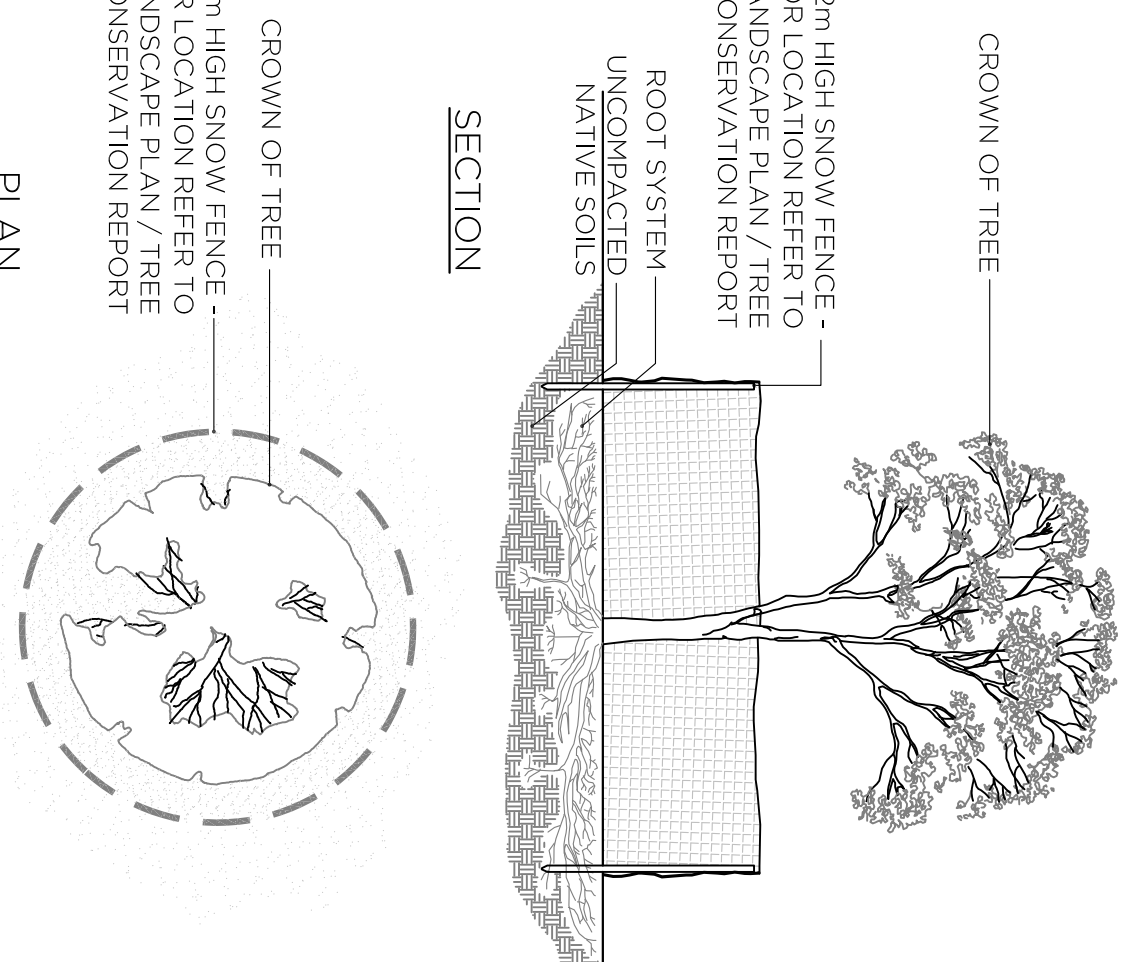

3 TREE PROTECTION FENCING N.T.S.
L-02

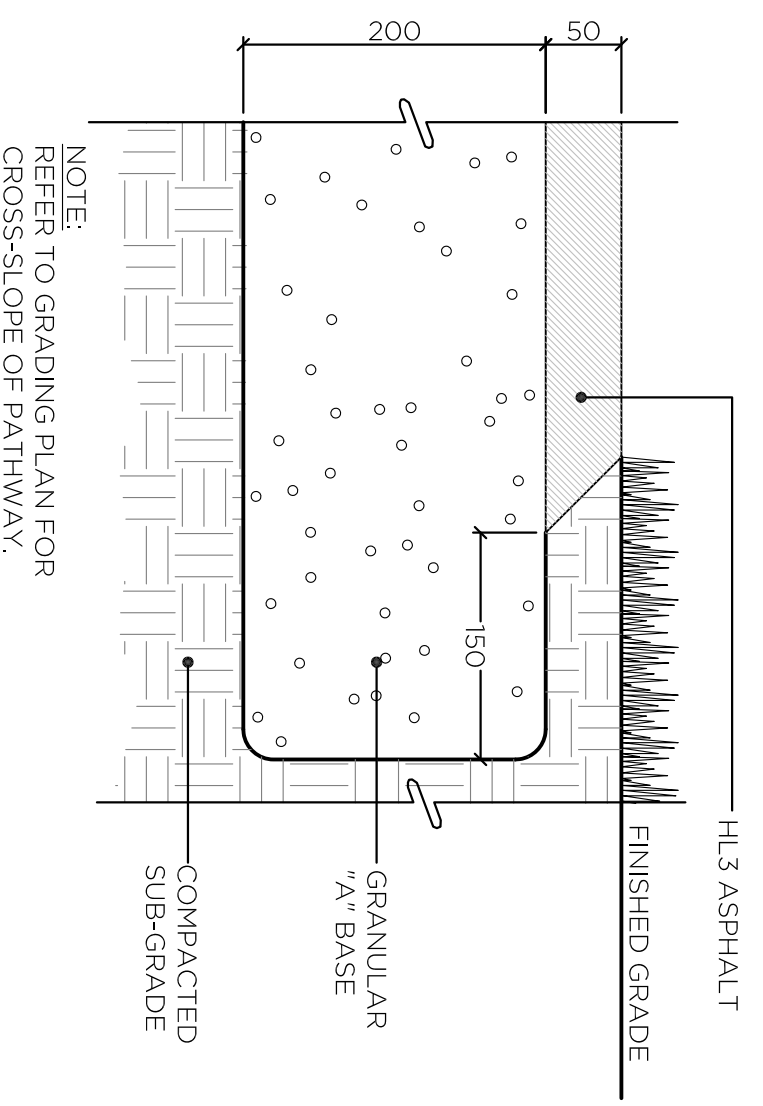

4 ASPHALT PATHWAY N.T.S.
L-02

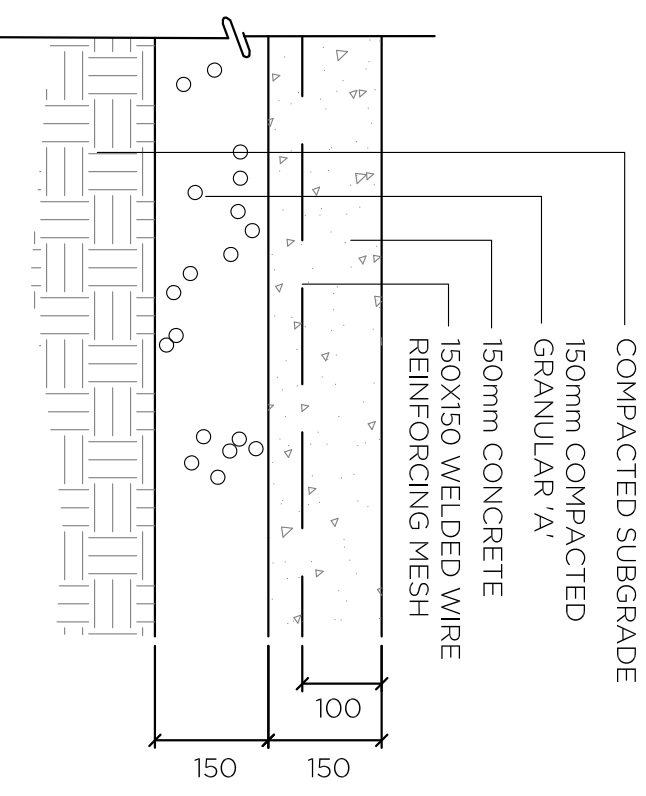

5 CONCRETE PAVEMENT N.T.S.
L-02

NO.	ISSUE & REVISIONS	DATE
2	FOR REVIEW	2014-01-31
1	FOR REVIEW	2014-01-27

- The General Contractor shall verify all conditions in the field and report any discrepancies to the Landscape Architect prior to construction.
- Any areas outside the limit of work damaged by the General Contractor shall be restored by the General Contractor to the satisfaction of the contract administrator at no additional cost to the Owner.
- All underground utilities to be located by the General Contractor prior to the commencement of any work.
- This drawing is a portion of a complete project and shall be read in conjunction with all other drawings, specifications and tender documents related to the project, regardless of origin.
- All measurements in millimeters unless otherwise noted. Do not scale drawings.
- No proposed retaining wall indicated on this drawing is to exceed an eight foot height above grade except in reference to engineering drawing.

SEAL PROJECT NORTH

FOTENN

PROJECT
239 CRAIG
HENRY DRIVE
OTTAWA, ON

DRAWING
LANDSCAPE DETAILS

SCALE:	AS NOTED	DRAWING NO.	L-02
DRAWN:	LM	CHECKED:	LM
DATE:	2014-01-24	REVISION NO.	