

## **APPENDIX A**

---

### **OC Transpo System Map**

# OC Transpo Downtown Route Map

★ Subject Site

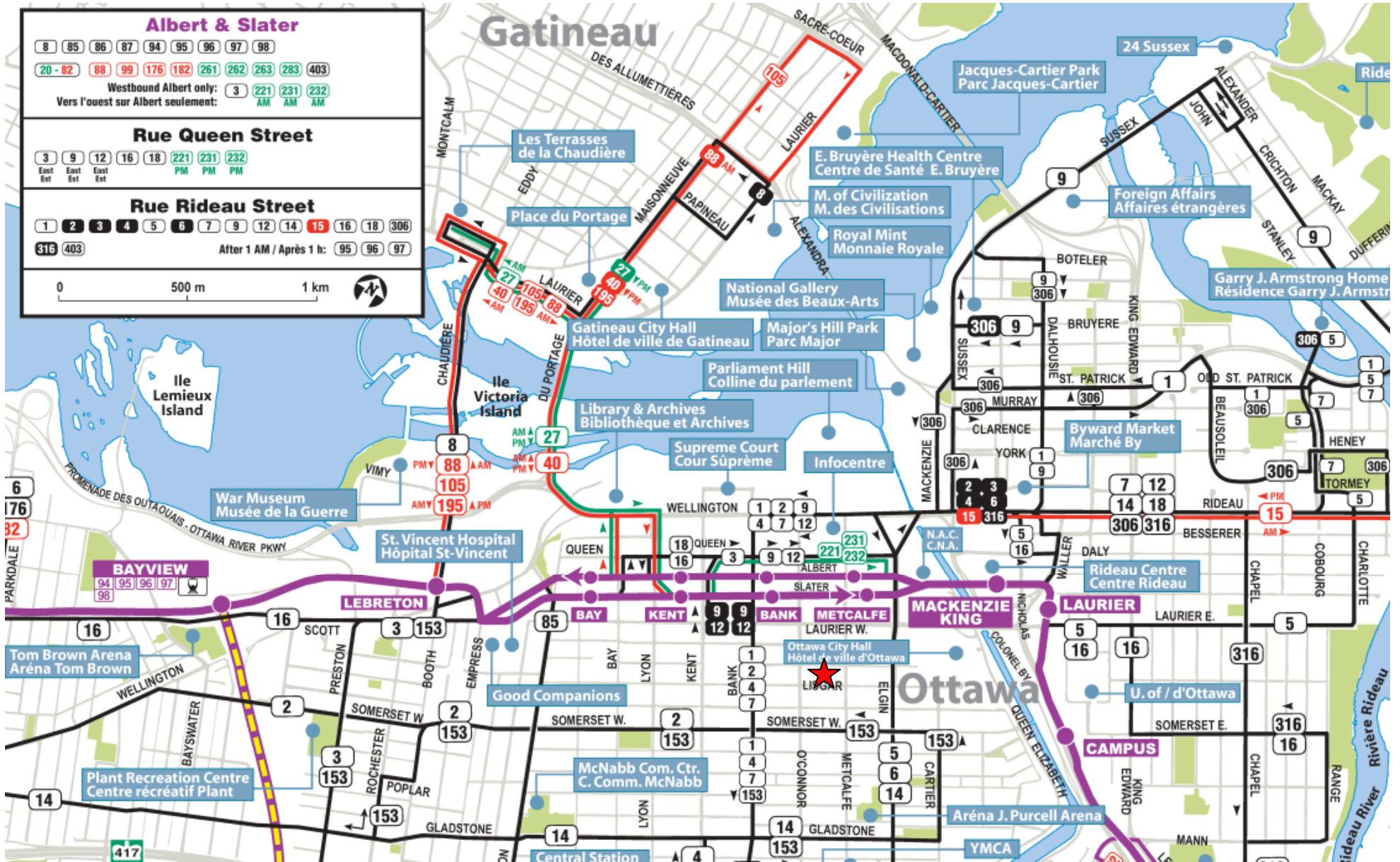

# OC Transpo Bus Stop Locations

★ Subject Site

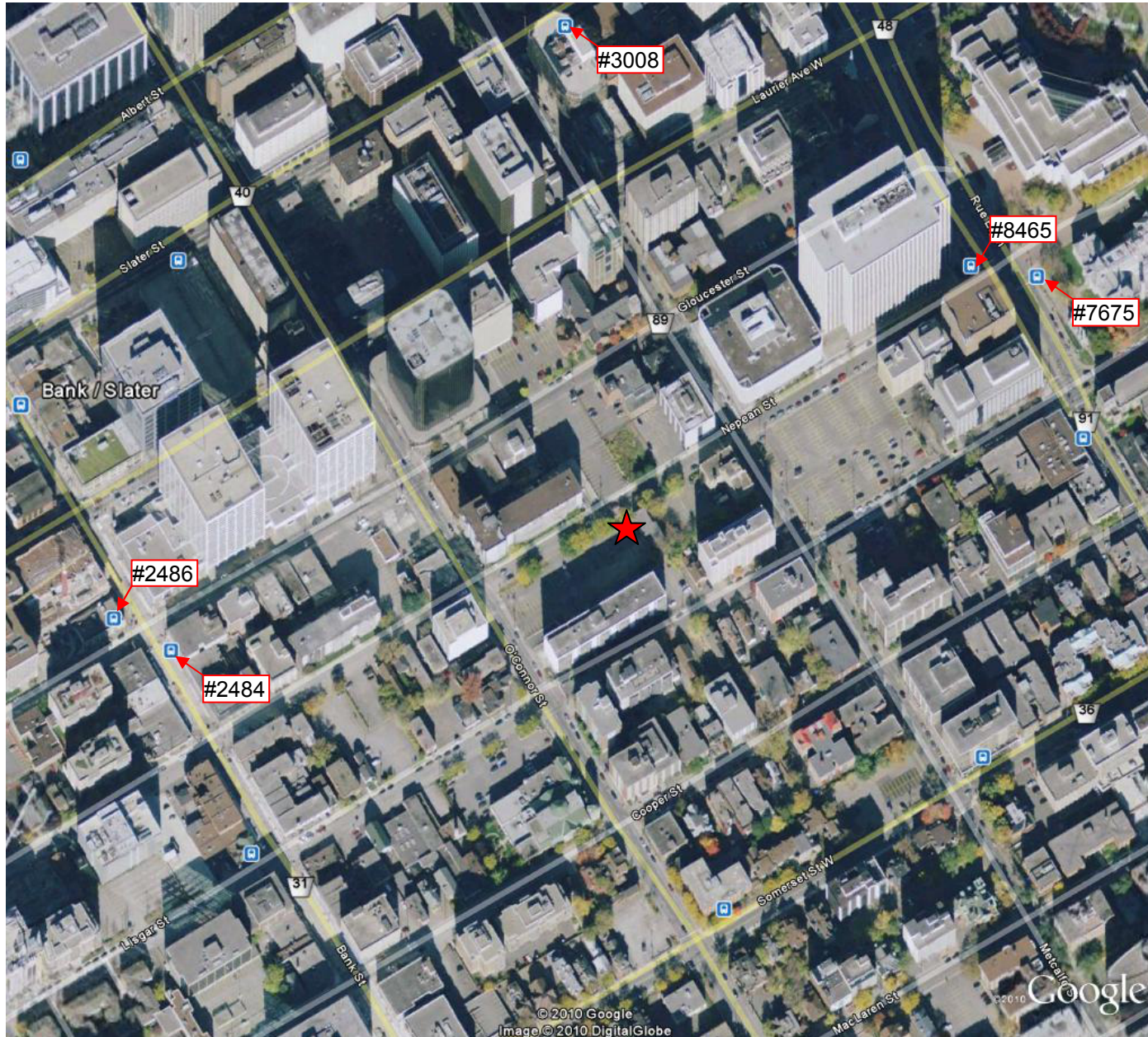

## **APPENDIX B**

---

### **Traffic Count Information**



**GLOUCESTER ST and O'CONNOR ST**  
(ULRS Listing GLOUCEST & OCONNOR)

Survey Date: Tuesday 27 July 2010  
Conditions: Dry  
Start Time: 0700

**Total Observed U-Turns**  
Northbound: 0 Southbound: 1  
Eastbound: 0 Westbound: 0

**AADT Factor**  
Tuesday in July is  
0.9

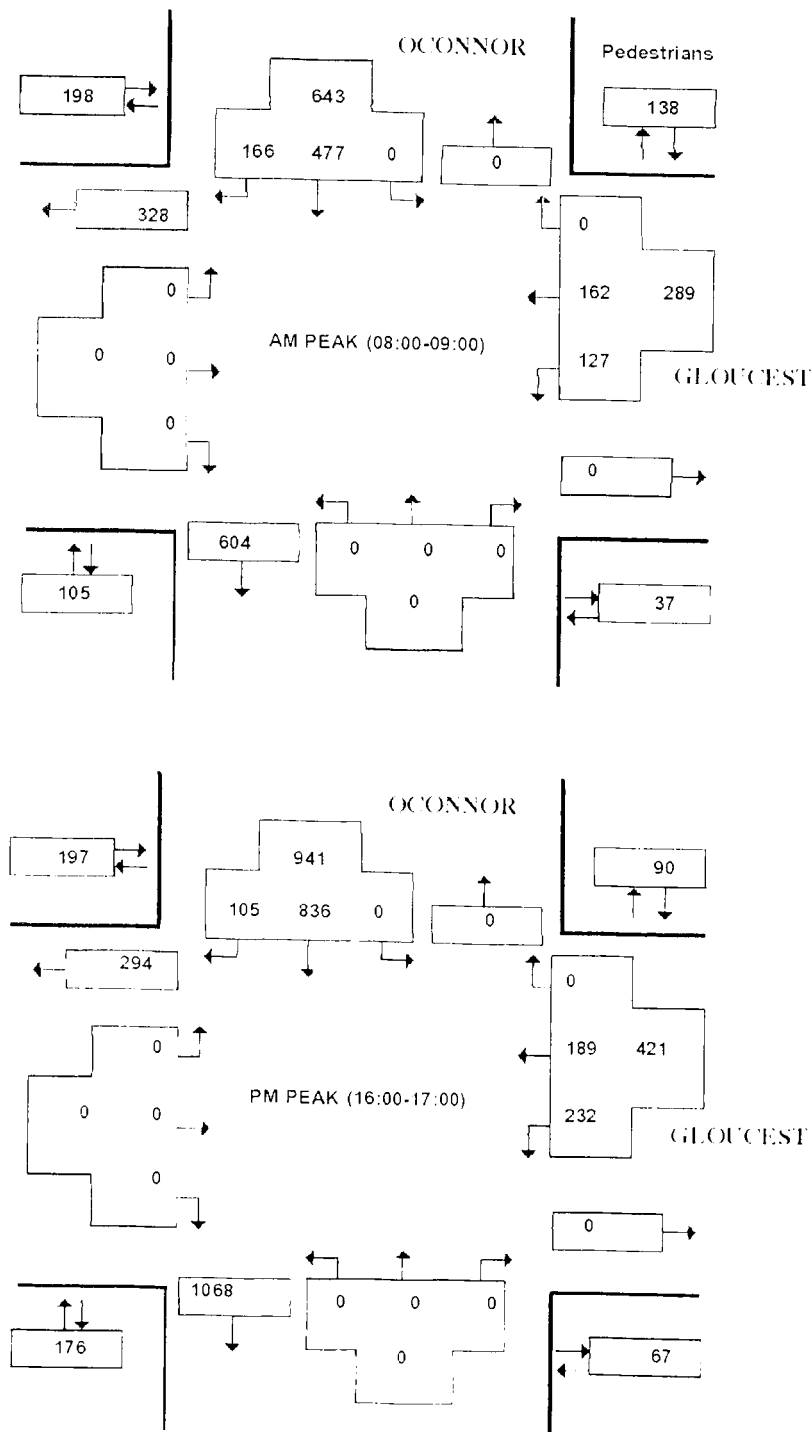



**NEPEAN ST and O'CONNOR ST**  
(HRS Listing NEPEAN & O'CONNOR)

Survey Date: Tuesday 4 May 2010  
 Conditions: dry  
 Start Time: 0700

Total Observed U-Turns  
 Northbound: 0 Southbound: 0  
 Eastbound: 0 Westbound: 0

AADU Factor  
 Tuesday in May is  
 0.9

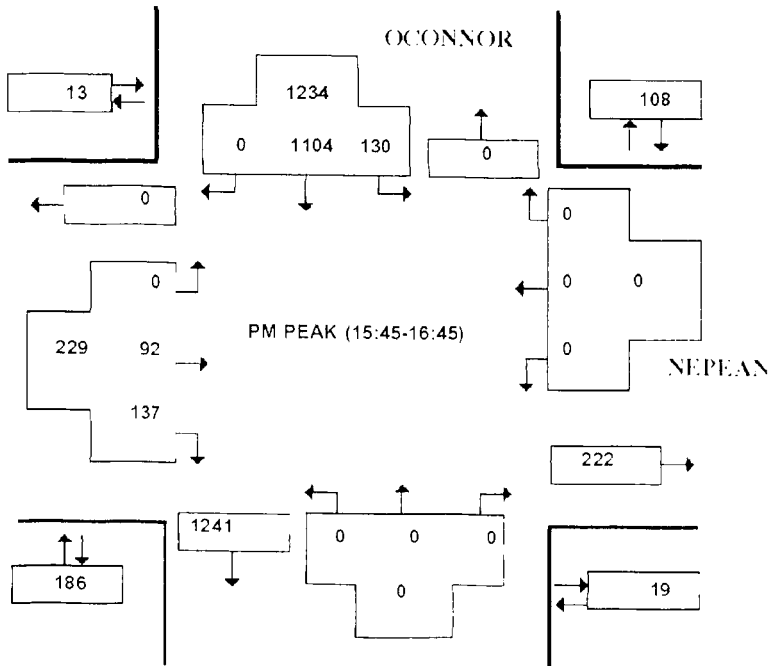
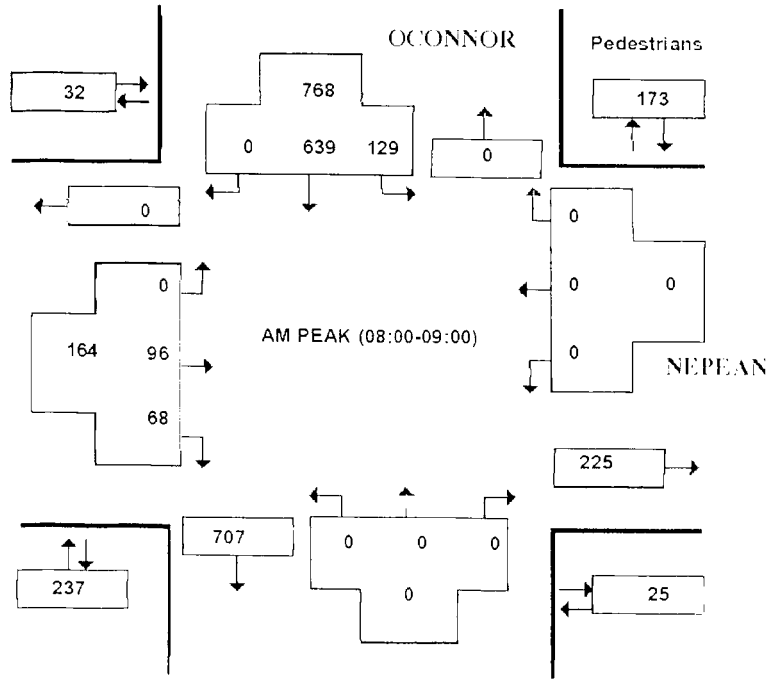

Weather: Overcast  
Serial Number: T12-1612, T12-1613  
Collected by: G. Bedrosian, K. Vogel  
Notes: Nepean Street Peds - Estimated

File Name : 2009oct06-8hour  
Site Code : 108020  
Start Date : 10/6/2009  
Page No : 3

Start Time	Metcalf Street Southbound		Nepean Street Westbound		Metcalf Street Northbound				Nepean Street Eastbound				Int. Total
	Peds	App. Total	Peds	App. Total	Thru	Right	Peds	App. Total	Left	Thru	Peds	App. Total	
Peak Hour Analysis From 07:00 to 09:45 - Peak 1 of 1													
Peak Hour for Entire Intersection Begins at 08:15													
08:15	48	48	10	10	235	32	81	348	20	29	10	59	465
08:30	49	49	10	10	216	52	73	341	18	25	10	53	453
08:45	80	80	10	10	206	45	96	347	12	21	10	43	480
09:00	48	48	10	10	197	54	80	331	16	9	10	35	424
Total Volume	225	225	40	40	854	183	330	1367	66	84	40	190	1822
% App. Total	100		100		62.5	13.4	24.1		34.7	44.2	21.1		
PHF	.703	.703	1.000	1.000	.909	.847	.859	.982	.825	.724	1.000	.805	.949

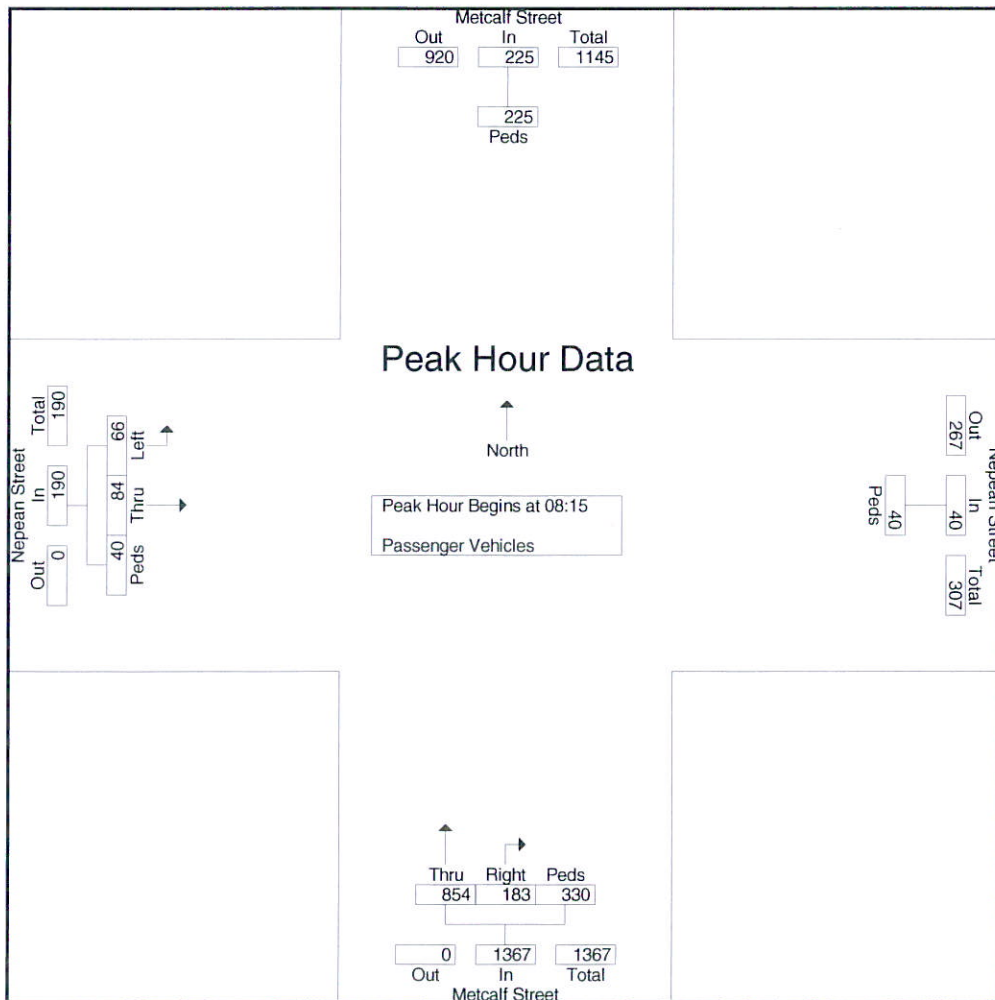



Weather: Overcast  
Serial Number: T12-1612, T12-1613  
Collected by: G. Bedrosian, K. Vogel  
Notes: Nepean Street Peds - Estimated

File Name : 2009oct06-8hour  
Site Code : 108020  
Start Date : 10/6/2009  
Page No : 5

Start Time	Metcalf Street Southbound		Nepean Street Westbound		Metcalf Street Northbound				Nepean Street Eastbound				Int. Total
	Peds	App. Total	Peds	App. Total	Thru	Right	Peds	App. Total	Left	Thru	Peds	App. Total	
Peak Hour Analysis From 14:00 to 17:45 - Peak 1 of 1													
Peak Hour for Entire Intersection Begins at 16:15													
16:15	37	37	10	10	94	20	40	154	30	29	10	69	270
16:30	37	37	10	10	113	23	52	188	29	36	10	75	310
16:45	40	40	10	10	119	26	52	197	28	25	10	63	310
17:00	32	32	10	10	114	21	88	223	25	24	10	59	324
Total Volume	146	146	40	40	440	90	232	762	112	114	40	266	1214
% App. Total	100		100		57.7	11.8	30.4		42.1	42.9	15		
PHF	.913	.913	1.000	1.000	.924	.865	.659	.854	.933	.792	1.000	.887	.937

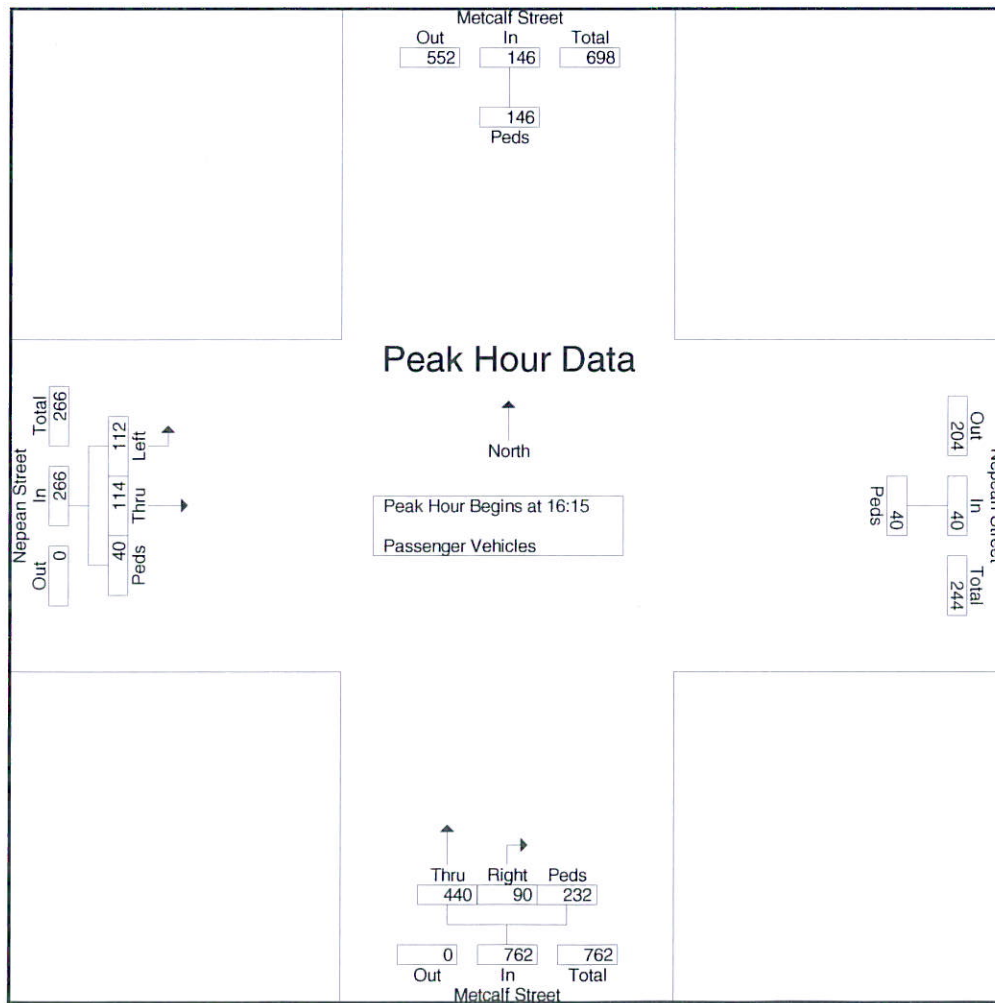

## **APPENDIX C**

---

### **Collision Data**

# Collision Main Detail Summary

OnTRAC Reporting System

FROM: 2008-01-01 TO: 2011-01-01

## GLoucester St & Metcalfe St

Former Municipality: Ottawa

Traffic Control: Traffic signal

Number of Collisions: 11

No.	DATE	DAY	TIME	ENV	IMPACT TYPE		CLASS	DIR	SURFACE COND'N	VEHICLE MANOEUVRE	VEHICLE TYPE	FIRST EVENT	No. PED
					LIGHT	ANGLE							
1	2008-02-09	Sat	19:50	Snow	Dark	Angle	Non-fatal	V1 N V2 W	Loose snow Loose snow	Going ahead Slowing or	Automobile, station Automobile, station	Other motor vehicle Other motor vehicle	0
2	2008-04-22	Tue	12:15	Clear	Daylight	Rear end	P.D. only	V1 N V2 N	Dry Dry	Going ahead Slowing or	Automobile, station Automobile, station	Other motor vehicle Other motor vehicle	0
3	2008-04-24	Thu	18:15	Clear	Daylight	Turning	P.D. only	V1 N V2 N	Dry Dry	Turning left Going ahead	Automobile, station Automobile, station	Other motor vehicle Other motor vehicle	0
4	2008-05-16	Frid	09:56	Clear	Daylight	Turning	P.D. only	V1 N V2 N	Dry Dry	Turning left Going ahead	Automobile, station Automobile, station	Other motor vehicle Other motor vehicle	0
5	2008-05-25	Sun	08:45	Clear	Daylight	Turning	P.D. only	V1 N V2 N	Dry Dry	Going ahead Turning left	Pick-up truck Automobile, station	Other motor vehicle Other motor vehicle	0
6	2008-07-21	Mo	09:33	Clear	Daylight	Turning	P.D. only	V1 W V2 W	Dry Dry	Turning right Going ahead	Truck - closed Automobile, station	Other motor vehicle Other motor vehicle	0
7	2008-10-30	Thu	10:23	Clear	Daylight	Rear end	P.D. only	V1 N V2 N	Dry Dry	Slowing or Stopped	Police vehicle Automobile, station	Other motor vehicle Other motor vehicle	0
8	2009-02-26	Thu	08:56	Clear	Daylight	Sideswipe	P.D. only	V1 N V2 N	Dry Dry	Changing lanes Going ahead	Automobile, station Truck - tractor	Other motor vehicle Other motor vehicle	0
9	2010-03-20	Sat	19:00	Clear	Dark	Turning	P.D. only	V1 N V2 N	Dry Dry	Turning left Going ahead	Automobile, station Automobile, station	Other motor vehicle Other motor vehicle	0
10	2010-08-25	We	15:46	Clear	Daylight	Sideswipe	P.D. only	V1 N V2 N	Dry Dry	Changing lanes Going ahead	Automobile, station Automobile, station	Other motor vehicle Other motor vehicle	0
11	2010-10-20	We	14:10	Clear	Daylight	Sideswipe	P.D. only	V1 N V2 N	Dry Dry	Pulling away Going ahead	Automobile, station Automobile, station	Other motor vehicle Other motor vehicle	0

## GLoucester St & O'Connor St

Former Municipality: Ottawa

Traffic Control: Traffic signal

Number of Collisions: 5

No.	DATE	DAY	TIME	ENV	IMPACT TYPE		CLASS	DIR	SURFACE COND'N	VEHICLE MANOEUVRE	VEHICLE TYPE	FIRST EVENT	No. PED
					LIGHT	ANGLE							
12	2008-02-25	Mo	16:15	Clear	Daylight	Single vehicle	Non-fatal	V1 S	Dry	Turning left	Passenger van	Pedestrian	1
13	2008-04-29	Tue	12:05	Clear	Daylight	Turning	P.D. only	V1 S V2 S	Dry Dry	Turning right Turning right	Truck - other Automobile, station	Other motor vehicle Other motor vehicle	0
14	2009-03-13	Frid	15:32	Clear	Daylight	Sideswipe	P.D. only	V1 S V2 S	Dry Dry	Changing lanes Turning right	Automobile, station Automobile, station	Other motor vehicle Other motor vehicle	0
15	2010-08-13	Frid	16:10	Clear	Daylight	Turning	P.D. only	V1 S V2 S	Dry Dry	Turning left Going ahead	Automobile, station Pick-up truck	Other motor vehicle Other motor vehicle	0
16	2010-12-09	Thu	10:45	Clear	Daylight	Angle	Non-fatal	V1 W V2 S	Dry Dry	Turning left Going ahead	Automobile, station Automobile, station	Other motor vehicle Other motor vehicle	0

(Note: Time of Day = "00:00" represents unknown collision time)

October 17, 2011

# Collision Main Detail Summary

OnTRAC Reporting System

FROM: 2008-01-01 TO: 2011-01-01

## METCALFE ST & NEPEAN ST

Former Municipality: Ottawa

Traffic Control: Stop sign

Number of Collisions: 11

	DATE	DAY	TIME	ENV	IMPACT TYPE		CLASS	DIR	SURFACE COND'N	VEHICLE MANOEUVRE	VEHICLE TYPE	FIRST EVENT	No. PED
					LIGHT								
17	2008-02-14	Thu	20:42	Clear	Dark	Angle	P.D. only	V1 E V2 N	Slush Slush	Going ahead Going ahead	Automobile, station Automobile, station	Other motor vehicle Other motor vehicle	0
18	2008-04-03	Thu	09:41	Clear	Daylight	Other	P.D. only	V1 S V2 E	Dry Dry	Reversing Going ahead	Automobile, station Automobile, station	Other motor vehicle Other motor vehicle	0
19	2008-06-18	We	21:49	Rain	Dark	Angle	P.D. only	V1 E V2 S	Wet Wet	Turning left Going ahead	Passenger van Passenger van	Other motor vehicle Other motor vehicle	0
20	2008-10-31	Frid	12:00	Clear	Daylight	Sideswipe	P.D. only	V1 E V2 E	Dry Dry	Merging Going ahead	Automobile, station Automobile, station	Other motor vehicle Other motor vehicle	0
21	2009-01-28	We	08:55	Snow	Daylight	Angle	P.D. only	V1 E V2 N	Loose snow Loose snow	Slowing or Going ahead	Delivery van Automobile, station	Other motor vehicle Other motor vehicle	0
22	2009-01-31	Sat	14:15	Clear	Daylight	Angle	P.D. only	V1 E V2 N	Loose snow Loose snow	Slowing or Going ahead	Pick-up truck Automobile, station	Skidding/Sliding Other motor vehicle	0
23	2009-03-20	Frid	22:25	Clear	Dark	Angle	P.D. only	V1 N V2 E	Dry Dry	Going ahead Going ahead	Automobile, station Passenger van	Other motor vehicle Other motor vehicle	0
24	2009-07-21	Tue	11:00	Clear	Daylight	Angle	P.D. only	V1 N V2 E	Dry Dry	Going ahead Going ahead	Pick-up truck Truck - closed	Other motor vehicle Other motor vehicle	0
25	2010-03-31	We	17:28	Clear	Daylight	Angle	P.D. only	V1 E V2 N	Dry Dry	Turning left Going ahead	Automobile, station Pick-up truck	Other motor vehicle Other motor vehicle	0
26	2010-04-20	Tue	08:38	Clear	Daylight	Angle	Non-fatal	V1 N V2 E	Dry Dry	Going ahead Going ahead	Bicycle Automobile, station	Other motor vehicle Cyclist	0
27	2010-12-01	We	10:51	Rain	Daylight	Turning	P.D. only	V1 N V2 N	Wet Wet	Turning right Going ahead	Automobile, station Truck - closed	Other motor vehicle Other motor vehicle	0

## NEPEAN ST & O'CONNOR ST

Former Municipality: Ottawa

Traffic Control: Stop sign

Number of Collisions: 26

	DATE	DAY	TIME	ENV	IMPACT TYPE		CLASS	DIR	SURFACE COND'N	VEHICLE MANOEUVRE	VEHICLE TYPE	FIRST EVENT	No. PED
					LIGHT								
28	2008-02-06	We	09:00	Snow	Daylight	Sideswipe	P.D. only	V1 S V2 S	Slush Slush	Changing lanes Going ahead	Automobile, station Automobile, station	Other motor vehicle Other motor vehicle	0
29	2008-03-28	Frid	16:10	Clear	Daylight	Angle	P.D. only	V1 E V2 S	Dry Dry	Going ahead Going ahead	Automobile, station Automobile, station	Other motor vehicle Other motor vehicle	0
30	2008-05-02	Frid	16:59	Clear	Daylight	Single vehicle	P.D. only	V1 S	Dry	Going ahead	Motorcycle	Other Fixed Objects	0
31	2008-07-09	We	16:23	Clear	Daylight	Angle	Non-fatal	V1 S V2 E	Dry Dry	Going ahead Going ahead	Automobile, station Passenger van	Other motor vehicle Other motor vehicle	0
32	2008-11-03	Mo	16:49	Clear	Dusk	Angle	P.D. only	V1 S V2 E	Dry Dry	Going ahead Going ahead	Automobile, station Pick-up truck	Other motor vehicle Other motor vehicle	0
33	2008-11-23	Sun	11:56	Clear	Daylight	Angle	P.D. only	V1 E V2 S	Dry Dry	Going ahead Going ahead	Automobile, station Pick-up truck	Other motor vehicle Other motor vehicle	0

(Note: Time of Day = "00:00" represents unknown collision time)

October 17, 2011

# Collision Main Detail Summary

OnTRAC Reporting System

FROM: 2008-01-01 TO: 2011-01-01

34	2008-12-10	We	08:47	Snow	Daylight	Angle	P.D. only	V1 E V2 S	Loose snow Loose snow	Going ahead Going ahead	Automobile, station Automobile, station	Other motor vehicle Other motor vehicle	0
35	2008-12-22	Mo	14:45	Clear	Daylight	Rear end	P.D. only	V1 S V2 S	Slush Slush	Slowing or Going ahead	Automobile, station Automobile, station	Other motor vehicle Other motor vehicle	0
36	2008-12-25	Thu	21:10	Snow	Dark	Angle	P.D. only	V1 S V2 E	Loose snow Loose snow	Going ahead Turning right	Unknown Automobile, station	Other motor vehicle Other motor vehicle	0
37	2009-01-07	We	10:20	Snow	Daylight	Turning	P.D. only	V1 S V2 S	Loose snow Loose snow	Going ahead Turning left	Pick-up truck Automobile, station	Other motor vehicle Other motor vehicle	0
38	2009-01-09	Frid	16:51	Clear	Dusk	Angle	P.D. only	V1 S V2 E	Loose snow Loose snow	Going ahead Going ahead	Automobile, station Automobile, station	Other motor vehicle Other motor vehicle	0
39	2009-04-02	Thu	17:15	Clear	Daylight	Turning	P.D. only	V1 S V2 S	Dry Dry	Going ahead Turning left	Automobile, station Passenger van	Other motor vehicle Other motor vehicle	0
40	2009-04-21	Tue	07:40	Rain	Daylight	Sideswipe	P.D. only	V1 S V2 S	Wet Wet	Going ahead Changing lanes	Automobile, station Pick-up truck	Other motor vehicle Other motor vehicle	0
41	2009-06-18	Thu	16:34	Rain	Daylight	Angle	P.D. only	V1 S V2 E	Wet Wet	Going ahead Going ahead	Automobile, station Automobile, station	Other motor vehicle Other motor vehicle	0
42	2009-06-26	Frid	08:45	Clear	Daylight	Sideswipe	P.D. only	V1 S V2 S	Dry Dry	Changing lanes Going ahead	Automobile, station Automobile, station	Other motor vehicle Other motor vehicle	0
43	2009-10-17	Sat	10:26	Clear	Daylight	Turning	Non-fatal	V1 S V2 S	Dry Dry	Turning left Going ahead	Automobile, station Automobile, station	Other motor vehicle Other motor vehicle	0
44	2009-10-22	Thu	16:30	Rain	Daylight	Sideswipe	P.D. only	V1 S V2 S	Wet Wet	Turning left Turning left	Automobile, station Automobile, station	Other motor vehicle Other motor vehicle	0
45	2009-11-05	Thu	19:06	Rain	Dark	Turning	P.D. only	V1 S V2 S	Wet Wet	Going ahead Turning left	Automobile, station Automobile, station	Other motor vehicle Other motor vehicle	0
46	2009-11-26	Thu	22:21	Rain	Dark	Rear end	P.D. only	V1 S V2 S	Wet Wet	Going ahead Turning left	Automobile, station Automobile, station	Other motor vehicle Other motor vehicle	0
47	2009-12-16	We	14:30	Snow	Daylight	Angle	P.D. only	V1 E V2 S	Wet Wet	Going ahead Going ahead	Automobile, station Automobile, station	Other motor vehicle Other motor vehicle	0
48	2010-01-15	Frid	11:53	Clear	Daylight	Angle	P.D. only	V1 S V2 E	Dry Dry	Going ahead Going ahead	Automobile, station Pick-up truck	Other motor vehicle Other motor vehicle	0
49	2010-03-23	Tue	16:45	Rain	Daylight	Turning	P.D. only	V1 S V2 S	Wet Wet	Turning left Going ahead	Pick-up truck Passenger van	Other motor vehicle Other motor vehicle	0
50	2010-06-15	Tue	17:20	Clear	Daylight	Angle	Non	V1 S V2 E	Dry Dry	Going ahead Going ahead	Automobile, station Automobile, station	Other motor vehicle Other motor vehicle	0
51	2010-08-03	Tue	17:00	Clear	Daylight	Angle	P.D. only	V1 E V2 S	Wet Wet	Going ahead Going ahead	Automobile, station Automobile, station	Other motor vehicle Other motor vehicle	0
52	2010-11-28	Sun	11:00	Rain	Daylight	Sideswipe	P.D. only	V1 S V2 S	Ice Ice	Changing lanes Turning left	Automobile, station Automobile, station	Other motor vehicle Other motor vehicle	0
53	2010-12-01	We	16:10	Rain	Dusk	Angle	Non-fatal	V1 E V2 S	Wet Wet	Going ahead Going ahead	Automobile, station Bicycle	Cyclist Other motor vehicle	0

(Note: Time of Day = "00:00" represents unknown collision time)

## **APPENDIX D1**

---

### **Intersection Analysis Reports (Background Traffic)**



Movement	EBL	EBT	EBR	WBL	WBT	WBR	NBL	NBT	NBR	SBL	SBT	SBR
Lane Configurations	↘	↑						↑↑↑				
Sign Control	Stop		Stop		Stop		Free		Free		Free	
Grade	0%		0%		0%		0%		0%		0%	
Volume (veh/h)	71	100	0	0	0	0	0	890	192	0	0	0
Peak Hour Factor	0.92	0.92	0.92	0.92	0.92	0.92	0.92	0.92	0.92	0.92	0.92	0.92
Hourly flow rate (vph)	77	109	0	0	0	0	0	967	209	0	0	0
Pedestrians	330		225		40		40		40		40	
Lane Width (m)	3.5		0.0		3.5		0.0		3.5		0.0	
Walking Speed (m/s)	1.2		1.2		1.2		1.2		1.2		1.2	
Percent Blockage	27		0		3		0		3		0	
Right turn flare (veh)												
Median type	None		None									
Median storage veh												
Upstream signal (m)											83	
pX, platoon unblocked												
vC, conflicting volume	692	1731	370	1391	1627	692	330			1401		
vC1, stage 1 conf vol												
vC2, stage 2 conf vol												
vCu, unblocked vol	692	1731	370	1391	1627	692	330			1401		
tC, single (s)	7.5	6.5	6.9	7.5	6.5	6.9	4.1			4.1		
tC, 2 stage (s)												
tF (s)	3.5	4.0	3.3	3.5	4.0	3.3	2.2			2.2		
p0 queue free %	60	0	100	0	100	100	100			100		
cM capacity (veh/h)	192	64	445	0	74	387	898			483		
<b>Direction, Lane #</b>	<b>EB 1</b>	<b>EB 2</b>	<b>NB 1</b>	<b>NB 2</b>	<b>NB 3</b>							
Volume Total	77	109	387	387	402							
Volume Left	77	0	0	0	0							
Volume Right	0	0	0	0	209							
cSH	192	64	1700	1700	1700							
Volume to Capacity	0.40	1.70	0.23	0.23	0.24							
Queue Length 95th (m)	13.6	74.3	0.0	0.0	0.0							
Control Delay (s)	35.8	480.2	0.0	0.0	0.0							
Lane LOS	E	F										
Approach Delay (s)	295.7		0.0									
Approach LOS	F											
<b>Intersection Summary</b>												
Average Delay			40.4									
Intersection Capacity Utilization			63.3%	ICU Level of Service	B							
Analysis Period (min)			15									



Movement	EBL	EBT	EBR	WBL	WBT	WBR	NBL	NBT	NBR	SBL	SBT	SBR
Lane Configurations		↑	↗								↑↑↑	
Sign Control		Stop			Stop			Free			Free	
Grade		0%			0%			0%			0%	
Volume (veh/h)	0	97	69	0	0	0	0	0	0	130	645	0
Peak Hour Factor	0.92	0.92	0.92	0.92	0.92	0.92	0.92	0.92	0.92	0.92	0.92	0.92
Hourly flow rate (vph)	0	105	75	0	0	0	0	0	0	141	701	0
Pedestrians		237			173			25			32	
Lane Width (m)		3.5			0.0			0.0			3.5	
Walking Speed (m/s)		1.2			1.2			1.2			1.2	
Percent Blockage		19			0			0			3	
Right turn flare (veh)			2									
Median type		None			None							
Median storage veh												
Upstream signal (m)											82	
pX, platoon unblocked												
vC, conflicting volume	1253	1394	437	746	1394	205	938			173		
vC1, stage 1 conf vol												
vC2, stage 2 conf vol												
vCu, unblocked vol	1253	1394	437	746	1394	205	938			173		
tC, single (s)	7.5	6.5	6.9	7.5	6.5	6.9	4.1			4.1		
tC, 2 stage (s)												
tF (s)	3.5	4.0	3.3	3.5	4.0	3.3	2.2			2.2		
p0 queue free %	100	0	84	0	100	100	100			90		
cM capacity (veh/h)	80	102	458	0	102	781	587			1401		
<b>Direction, Lane #</b>	<b>EB 1</b>	<b>SB 1</b>	<b>SB 2</b>	<b>SB 3</b>	<b>SB 4</b>							
Volume Total	180	241	200	200	200							
Volume Left	0	141	0	0	0							
Volume Right	75	0	0	0	0							
cSH	159	1401	1700	1700	1700							
Volume to Capacity	1.14	0.10	0.12	0.12	0.12							
Queue Length 95th (m)	73.7	2.6	0.0	0.0	0.0							
Control Delay (s)	170.6	4.9	0.0	0.0	0.0							
Lane LOS	F	A										
Approach Delay (s)	170.6	1.4										
Approach LOS	F											
<b>Intersection Summary</b>												
Average Delay			31.3									
Intersection Capacity Utilization			42.0%	ICU Level of Service	A							
Analysis Period (min)			15									





Lane Group	EBL	EBT	EBR	WBL	WBT	WBR	NBL	NBT	NBR	SBL	SBT	SBR
Lane Configurations					↑	↗		↖↖↖				
Ideal Flow (vphpl)	1750	1750	1750	1750	1750	1750	1750	1750	1750	1750	1750	1750
Storage Length (m)	0.0		0.0	0.0		15.0	0.0		0.0	0.0		0.0
Storage Lanes	0		0	0		1	0		0	0		0
Total Lost Time (s)	4.0	4.0	4.0	4.0	4.0	4.0	4.0	4.0	4.0	4.0	4.0	4.0
Turning Speed (k/h)	24		14	24		14	24		14	24		14
Lane Util. Factor	1.00	1.00	1.00	1.00	1.00	1.00	0.91	0.91	1.00	1.00	1.00	1.00
Ped Bike Factor						0.87		0.96				
Frt						0.850						
Flt Protected								0.984				
Satd. Flow (prot)	0	0	0	0	1697	1442	0	4558	0	0	0	0
Flt Permitted								0.984				
Satd. Flow (perm)	0	0	0	0	1697	1259	0	4357	0	0	0	0
Right Turn on Red			Yes			Yes	Yes		Yes			Yes
Satd. Flow (RTOR)						64		246				
Headway Factor	1.01	1.01	1.01	1.01	1.01	1.01	1.01	1.01	1.01	1.01	1.01	1.01
Link Speed (k/h)		50			50			50			50	
Link Distance (m)		182.2			96.8			83.3			76.7	
Travel Time (s)		13.1			7.0			6.0			5.5	
Volume (vph)	0	0	0	0	134	59	226	464	0	0	0	0
Confl. Peds. (#/hr)	54		59	59		54	112		267	267		112
Confl. Bikes (#/hr)						60						9
Peak Hour Factor	0.92	0.92	0.92	0.92	0.92	0.92	0.92	0.92	0.92	0.92	0.92	0.92
Adj. Flow (vph)	0	0	0	0	146	64	246	504	0	0	0	0
Lane Group Flow (vph)	0	0	0	0	146	64	0	750	0	0	0	0
Turn Type						Perm	Perm					
Protected Phases					8			2				
Permitted Phases						8	2					
Minimum Split (s)					19.0	19.0	30.0	30.0				
Total Split (s)	0.0	0.0	0.0	0.0	19.0	19.0	41.0	41.0	0.0	0.0	0.0	0.0
Total Split (%)	0.0%	0.0%	0.0%	0.0%	31.7%	31.7%	68.3%	68.3%	0.0%	0.0%	0.0%	0.0%
Maximum Green (s)					14.0	14.0	36.0	36.0				
Yellow Time (s)					3.3	3.3	3.3	3.3				
All-Red Time (s)					1.7	1.7	1.7	1.7				
Lead/Lag												
Lead-Lag Optimize?												
Walk Time (s)					7.0	7.0	19.0	19.0				
Flash Dont Walk (s)					7.0	7.0	6.0	6.0				
Pedestrian Calls (#/hr)					20	20	40	40				
Act Effct Green (s)					15.0	15.0		37.0				
Actuated g/C Ratio					0.25	0.25		0.62				
v/c Ratio					0.34	0.18		0.27				
Control Delay					21.3	7.0		3.7				
Queue Delay					0.0	0.0		0.0				
Total Delay					21.3	7.0		3.7				
LOS					C	A		A				
Approach Delay					16.9			3.7				
Approach LOS					B			A				

Intersection Summary

Area Type:	Other
Cycle Length:	60
Actuated Cycle Length:	60
Offset:	33 (55%), Referenced to phase 2:NBTL and 6:., Start of Green
Natural Cycle:	50
Control Type:	Pretimed
Maximum v/c Ratio:	0.34
Intersection Signal Delay:	6.6
Intersection LOS:	A
Intersection Capacity Utilization	39.2%
ICU Level of Service	A
Analysis Period (min)	15

Splits and Phases: 15: Gloucester & Metcalfe

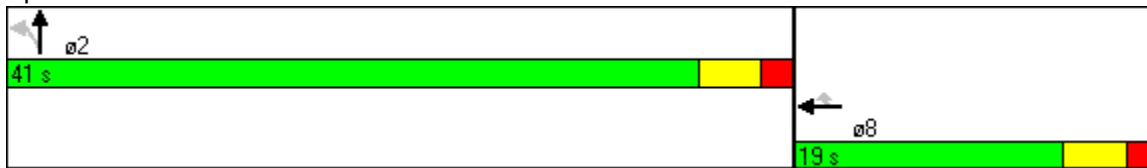



Lane Group	EBL	EBT	EBR	WBL	WBT	WBR	NBL	NBT	NBR	SBL	SBT	SBR
Lane Configurations				↙	↘						↑↑↑	
Ideal Flow (vphpl)	1750	1750	1750	1750	1750	1750	1750	1750	1750	1750	1750	1750
Storage Length (m)	0.0		0.0	15.0		0.0	0.0		0.0	0.0		0.0
Storage Lanes	0		0	1		0	0		0	0		0
Total Lost Time (s)	4.0	4.0	4.0	4.0	4.0	4.0	4.0	4.0	4.0	4.0	4.0	4.0
Turning Speed (k/h)	24		14	24		14	24		14	24		14
Lane Util. Factor	1.00	1.00	1.00	1.00	1.00	1.00	1.00	1.00	1.00	1.00	0.86	0.86
Ped Bike Factor				0.96							0.95	
Frt											0.961	
Flt Protected				0.950								
Satd. Flow (prot)	0	0	0	1612	1697	0	0	0	0	0	5350	0
Flt Permitted				0.950								
Satd. Flow (perm)	0	0	0	1540	1697	0	0	0	0	0	5350	0
Right Turn on Red			Yes	Yes		Yes			Yes			Yes
Satd. Flow (RTOR)				138							113	
Headway Factor	1.01	1.01	1.01	1.01	1.01	1.01	1.01	1.01	1.01	1.01	1.01	1.01
Link Speed (k/h)		50			50			50			50	
Link Distance (m)		108.3			182.2			82.4			78.3	
Travel Time (s)		7.8			13.1			5.9			5.6	
Volume (vph)	0	0	0	128	164	0	0	0	0	0	482	168
Confl. Peds. (#/hr)	198		37	37		198	105		138	138		105
Confl. Bikes (#/hr)			34			1						29
Peak Hour Factor	0.92	0.92	0.92	0.92	0.92	0.92	0.92	0.92	0.92	0.92	0.92	0.92
Adj. Flow (vph)	0	0	0	139	178	0	0	0	0	0	524	183
Lane Group Flow (vph)	0	0	0	139	178	0	0	0	0	0	707	0
Turn Type				Perm								
Protected Phases					8						6	
Permitted Phases				8								
Minimum Split (s)				25.0	25.0						35.0	
Total Split (s)	0.0	0.0	0.0	25.0	25.0	0.0	0.0	0.0	0.0	0.0	35.0	0.0
Total Split (%)	0.0%	0.0%	0.0%	41.7%	41.7%	0.0%	0.0%	0.0%	0.0%	0.0%	58.3%	0.0%
Maximum Green (s)				19.7	19.7						29.9	
Yellow Time (s)				3.3	3.3						3.3	
All-Red Time (s)				2.0	2.0						1.8	
Lead/Lag												
Lead-Lag Optimize?												
Walk Time (s)				7.0	7.0						15.0	
Flash Dont Walk (s)				8.0	8.0						7.0	
Pedestrian Calls (#/hr)				20	20						40	
Act Effct Green (s)				21.0	21.0						31.0	
Actuated g/C Ratio				0.35	0.35						0.52	
v/c Ratio				0.22	0.30						0.25	
Control Delay				2.8	12.3						6.9	
Queue Delay				0.0	0.0						0.0	
Total Delay				2.8	12.3						6.9	
LOS				A	B						A	
Approach Delay					8.1						6.9	
Approach LOS					A						A	

Intersection Summary

Area Type:	Other		
Cycle Length:	60		
Actuated Cycle Length:	60		
Offset:	1 (2%), Referenced to phase 2: and 6:SBT, Start of Green		
Natural Cycle:	60		
Control Type:	Pretimed		
Maximum v/c Ratio:	0.30		
Intersection Signal Delay:	7.3	Intersection LOS:	A
Intersection Capacity Utilization	39.2%	ICU Level of Service	A
Analysis Period (min)	15		

Splits and Phases: 16: Gloucester & O'Connor





Movement	EBL	EBT	EBR	WBL	WBT	WBR	NBL	NBT	NBR	SBL	SBT	SBR
Lane Configurations	↘	↑						↑↑↑				
Sign Control		Stop			Stop			Free			Free	
Grade		0%			0%			0%			0%	
Volume (veh/h)	115	118	0	0	0	0	0	464	94	0	0	0
Peak Hour Factor	0.92	0.92	0.92	0.92	0.92	0.92	0.92	0.92	0.92	0.92	0.92	0.92
Hourly flow rate (vph)	125	128	0	0	0	0	0	504	102	0	0	0
Pedestrians		232			146			40			40	
Lane Width (m)		3.5			0.0			3.5			0.0	
Walking Speed (m/s)		1.2			1.2			1.2			1.2	
Percent Blockage		19			0			3			0	
Right turn flare (veh)												
Median type		None			None							
Median storage veh												
Upstream signal (m)											83	
pX, platoon unblocked												
vC, conflicting volume	440	985	272	806	933	405	232			753		
vC1, stage 1 conf vol												
vC2, stage 2 conf vol												
vCu, unblocked vol	440	985	272	806	933	405	232			753		
tC, single (s)	7.5	6.5	6.9	7.5	6.5	6.9	4.1			4.1		
tC, 2 stage (s)												
tF (s)	3.5	4.0	3.3	3.5	4.0	3.3	2.2			2.2		
p0 queue free %	64	36	100	100	100	100	100			100		
cM capacity (veh/h)	348	200	570	113	215	595	1082			853		
<b>Direction, Lane #</b>	<b>EB 1</b>	<b>EB 2</b>	<b>NB 1</b>	<b>NB 2</b>	<b>NB 3</b>							
Volume Total	125	128	202	202	203							
Volume Left	125	0	0	0	0							
Volume Right	0	0	0	0	102							
cSH	348	200	1700	1700	1700							
Volume to Capacity	0.36	0.64	0.12	0.12	0.12							
Queue Length 95th (m)	12.1	28.6	0.0	0.0	0.0							
Control Delay (s)	21.0	50.3	0.0	0.0	0.0							
Lane LOS	C	F										
Approach Delay (s)	35.8		0.0									
Approach LOS	E											
<b>Intersection Summary</b>												
Average Delay			10.6									
Intersection Capacity Utilization			57.7%	ICU Level of Service	B							
Analysis Period (min)			15									



Movement	EBL	EBT	EBR	WBL	WBT	WBR	NBL	NBT	NBR	SBL	SBT	SBR
Lane Configurations		↑	↗								↑↑↑	
Sign Control		Stop			Stop			Free			Free	
Grade		0%			0%			0%			0%	
Volume (veh/h)	0	97	69	0	0	0	0	0	0	131	1115	0
Peak Hour Factor	0.92	0.92	0.92	0.92	0.92	0.92	0.92	0.92	0.92	0.92	0.92	0.92
Hourly flow rate (vph)	0	105	75	0	0	0	0	0	0	142	1212	0
Pedestrians		186			108			19			13	
Lane Width (m)		3.5			0.0			0.0			3.5	
Walking Speed (m/s)		1.2			1.2			1.2			1.2	
Percent Blockage		15			0			0			1	
Right turn flare (veh)			2									
Median type		None			None							
Median storage veh												
Upstream signal (m)											82	
pX, platoon unblocked	0.95	0.95	0.95	0.95	0.95		0.95					
vC, conflicting volume	1696	1791	508	805	1791	121	1398			108		
vC1, stage 1 conf vol												
vC2, stage 2 conf vol												
vCu, unblocked vol	1573	1673	322	635	1673	121	1259			108		
tC, single (s)	7.5	6.5	6.9	7.5	6.5	6.9	4.1			4.1		
tC, 2 stage (s)												
tF (s)	3.5	4.0	3.3	3.5	4.0	3.3	2.2			2.2		
p0 queue free %	100	0	86	0	100	100	100			90		
cM capacity (veh/h)	49	69	543	0	69	898	442			1480		

Direction, Lane #	EB 1	SB 1	SB 2	SB 3	SB 4
Volume Total	180	316	346	346	346
Volume Left	0	142	0	0	0
Volume Right	75	0	0	0	0
cSH	110	1480	1700	1700	1700
Volume to Capacity	1.64	0.10	0.20	0.20	0.20
Queue Length 95th (m)	104.5	2.4	0.0	0.0	0.0
Control Delay (s)	394.9	3.9	0.0	0.0	0.0
Lane LOS	F	A			
Approach Delay (s)	394.9	0.9			
Approach LOS	F				

Intersection Summary		
Average Delay		47.2
Intersection Capacity Utilization	36.1%	ICU Level of Service
Analysis Period (min)		15
		A



Lane Group	EBL	EBT	EBR	WBL	WBT	WBR	NBL	NBT	NBR	SBL	SBT	SBR
Lane Configurations					↑	↗		↖↖↖				
Ideal Flow (vphpl)	1750	1750	1750	1750	1750	1750	1750	1750	1750	1750	1750	1750
Storage Length (m)	0.0		0.0	0.0		15.0	0.0		0.0	0.0		0.0
Storage Lanes	0		0	0		1	0		0	0		0
Total Lost Time (s)	4.0	4.0	4.0	4.0	4.0	4.0	4.0	4.0	4.0	4.0	4.0	4.0
Turning Speed (k/h)	24		14	24		14	24		14	24		14
Lane Util. Factor	1.00	1.00	1.00	1.00	1.00	1.00	0.91	0.91	1.00	1.00	1.00	1.00
Ped Bike Factor						0.92		0.93				
Frt						0.850						
Flt Protected								0.987				
Satd. Flow (prot)	0	0	0	0	1697	1442	0	4572	0	0	0	0
Flt Permitted								0.987				
Satd. Flow (perm)	0	0	0	0	1697	1325	0	4244	0	0	0	0
Right Turn on Red			Yes			Yes	Yes		Yes			Yes
Satd. Flow (RTOR)						107		143				
Headway Factor	1.01	1.01	1.01	1.01	1.01	1.01	1.01	1.01	1.01	1.01	1.01	1.01
Link Speed (k/h)		50			50			50			50	
Link Distance (m)		182.2			96.8			83.3			76.7	
Travel Time (s)		13.1			7.0			6.0			5.5	
Volume (vph)	0	0	0	0	188	98	132	377	0	0	0	0
Confl. Peds. (#/hr)	46		78	78		46	231		303	303		231
Confl. Bikes (#/hr)						14						2
Peak Hour Factor	0.92	0.92	0.92	0.92	0.92	0.92	0.92	0.92	0.92	0.92	0.92	0.92
Adj. Flow (vph)	0	0	0	0	204	107	143	410	0	0	0	0
Lane Group Flow (vph)	0	0	0	0	204	107	0	553	0	0	0	0
Turn Type						Perm	Perm					
Protected Phases					8			2				
Permitted Phases						8	2					
Minimum Split (s)					19.0	19.0	30.0	30.0				
Total Split (s)	0.0	0.0	0.0	0.0	19.0	19.0	41.0	41.0	0.0	0.0	0.0	0.0
Total Split (%)	0.0%	0.0%	0.0%	0.0%	31.7%	31.7%	68.3%	68.3%	0.0%	0.0%	0.0%	0.0%
Maximum Green (s)					14.0	14.0	36.0	36.0				
Yellow Time (s)					3.3	3.3	3.3	3.3				
All-Red Time (s)					1.7	1.7	1.7	1.7				
Lead/Lag												
Lead-Lag Optimize?												
Walk Time (s)					7.0	7.0	19.0	19.0				
Flash Dont Walk (s)					7.0	7.0	6.0	6.0				
Pedestrian Calls (#/hr)					20	20	40	40				
Act Effct Green (s)					15.0	15.0		37.0				
Actuated g/C Ratio					0.25	0.25		0.62				
v/c Ratio					0.48	0.26		0.21				
Control Delay					23.7	6.4		3.9				
Queue Delay					0.0	0.0		0.0				
Total Delay					23.7	6.4		3.9				
LOS					C	A		A				
Approach Delay					17.8			3.9				
Approach LOS					B			A				

Intersection Summary

Area Type:	Other
Cycle Length:	60
Actuated Cycle Length:	60
Offset:	33 (55%), Referenced to phase 2:NBTL and 6:., Start of Green
Natural Cycle:	50
Control Type:	Pretimed
Maximum v/c Ratio:	0.48
Intersection Signal Delay:	8.9
Intersection LOS:	A
Intersection Capacity Utilization	39.2%
ICU Level of Service	A
Analysis Period (min)	15

Splits and Phases: 15: Gloucester & Metcalfe

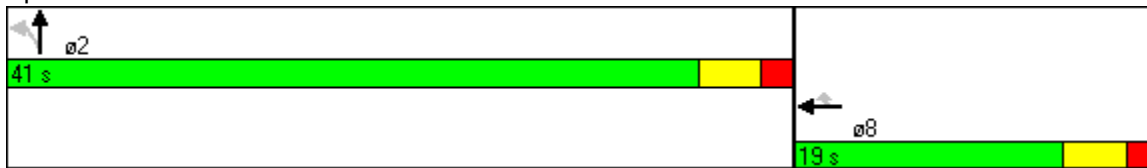





Lane Group	EBL	EBT	EBR	WBL	WBT	WBR	NBL	NBT	NBR	SBL	SBT	SBR
Lane Configurations				↙	↘						↑↑↑	
Ideal Flow (vphpl)	1750	1750	1750	1750	1750	1750	1750	1750	1750	1750	1750	1750
Storage Length (m)	0.0		0.0	15.0		0.0	0.0		0.0	0.0		0.0
Storage Lanes	0		0	1		0	0		0	0		0
Total Lost Time (s)	4.0	4.0	4.0	4.0	4.0	4.0	4.0	4.0	4.0	4.0	4.0	4.0
Turning Speed (k/h)	24		14	24		14	24		14	24		14
Lane Util. Factor	1.00	1.00	1.00	1.00	1.00	1.00	1.00	1.00	1.00	1.00	0.86	0.86
Ped Bike Factor				0.93							0.97	
Frt											0.983	
Flt Protected				0.950								
Satd. Flow (prot)	0	0	0	1612	1697	0	0	0	0	0	5580	0
Flt Permitted				0.950								
Satd. Flow (perm)	0	0	0	1493	1697	0	0	0	0	0	5580	0
Right Turn on Red			Yes	Yes		Yes			Yes			Yes
Satd. Flow (RTOR)				53							80	
Headway Factor	1.01	1.01	1.01	1.01	1.01	1.01	1.01	1.01	1.01	1.01	1.01	1.01
Link Speed (k/h)		50			50			50			50	
Link Distance (m)		108.3			182.2			82.4			78.3	
Travel Time (s)		7.8			13.1			5.9			5.6	
Volume (vph)	0	0	0	234	191	0	0	0	0	0	844	106
Confl. Peds. (#/hr)	197		67	67		197	176		90	90		176
Confl. Bikes (#/hr)			66									17
Peak Hour Factor	0.92	0.92	0.92	0.92	0.92	0.92	0.92	0.92	0.92	0.92	0.92	0.92
Adj. Flow (vph)	0	0	0	254	208	0	0	0	0	0	917	115
Lane Group Flow (vph)	0	0	0	254	208	0	0	0	0	0	1032	0
Turn Type				Perm								
Protected Phases					8						6	
Permitted Phases				8								
Minimum Split (s)				20.3	20.3						27.1	
Total Split (s)	0.0	0.0	0.0	24.0	24.0	0.0	0.0	0.0	0.0	0.0	31.0	0.0
Total Split (%)	0.0%	0.0%	0.0%	43.6%	43.6%	0.0%	0.0%	0.0%	0.0%	0.0%	56.4%	0.0%
Maximum Green (s)				18.7	18.7						25.9	
Yellow Time (s)				3.3	3.3						3.3	
All-Red Time (s)				2.0	2.0						1.8	
Lead/Lag												
Lead-Lag Optimize?												
Walk Time (s)				7.0	7.0						15.0	
Flash Dont Walk (s)				8.0	8.0						7.0	
Pedestrian Calls (#/hr)				20	20						40	
Act Effct Green (s)				20.0	20.0						27.0	
Actuated g/C Ratio				0.36	0.36						0.49	
v/c Ratio				0.44	0.34						0.37	
Control Delay				13.3	14.6						8.4	
Queue Delay				0.0	0.0						0.0	
Total Delay				13.3	14.6						8.4	
LOS				B	B						A	
Approach Delay					13.9						8.4	
Approach LOS					B						A	

Intersection Summary

Area Type:	Other		
Cycle Length:	55		
Actuated Cycle Length:	55		
Offset:	13 (24%), Referenced to phase 2: and 6:SBT, Start of Green		
Natural Cycle:	50		
Control Type:	Pretimed		
Maximum v/c Ratio:	0.44		
Intersection Signal Delay:	10.1	Intersection LOS:	B
Intersection Capacity Utilization	39.2%	ICU Level of Service	A
Analysis Period (min)	15		

Splits and Phases: 16: Gloucester & O'Connor





Movement	EBL	EBT	EBR	WBL	WBT	WBR	NBL	NBT	NBR	SBL	SBT	SBR
Lane Configurations	↘	↑						↑↑↑				
Sign Control		Stop			Stop			Free			Free	
Grade		0%			0%			0%			0%	
Volume (veh/h)	141	125	0	0	0	0	0	913	248	0	0	0
Peak Hour Factor	0.92	0.92	0.92	0.92	0.92	0.92	0.92	0.92	0.92	0.92	0.92	0.92
Hourly flow rate (vph)	153	136	0	0	0	0	0	992	270	0	0	0
Pedestrians		330			225			40			40	
Lane Width (m)		3.5			0.0			3.5			0.0	
Walking Speed (m/s)		1.2			1.2			1.2			1.2	
Percent Blockage		27			0			3			0	
Right turn flare (veh)												
Median type		None			None							
Median storage (veh)												
Upstream signal (m)												83
pX, platoon unblocked												
vC, conflicting volume	701	1817	370	1460	1682	731	330			1487		
vC1, stage 1 conf vol												
vC2, stage 2 conf vol												
vCu, unblocked vol	701	1817	370	1460	1682	731	330			1487		
tC, single (s)	7.5	6.5	6.9	7.5	6.5	6.9	4.1			4.1		
tC, 2 stage (s)												
tF (s)	3.5	4.0	3.3	3.5	4.0	3.3	2.2			2.2		
p0 queue free %	19	0	100	0	100	100	100			100		
cM capacity (veh/h)	189	56	445	0	68	364	898			448		
<b>Direction, Lane #</b>	<b>EB 1</b>	<b>EB 2</b>	<b>NB 1</b>	<b>NB 2</b>	<b>NB 3</b>							
Volume Total	153	136	397	397	468							
Volume Left	153	0	0	0	0							
Volume Right	0	0	0	0	270							
cSH	189	56	1700	1700	1700							
Volume to Capacity	0.81	2.41	0.23	0.23	0.28							
Queue Length 95th (m)	43.0	103.8	0.0	0.0	0.0							
Control Delay (s)	74.8	796.0	0.0	0.0	0.0							
Lane LOS	F	F										
Approach Delay (s)	413.7		0.0									
Approach LOS	F											
<b>Intersection Summary</b>												
Average Delay			77.1									
Intersection Capacity Utilization			66.4%	ICU Level of Service	C							
Analysis Period (min)			15									



Movement	EBL	EBT	EBR	WBL	WBT	WBR	NBL	NBT	NBR	SBL	SBT	SBR
Lane Configurations		↑	↗								↑↑↑	
Sign Control		Stop			Stop			Free			Free	
Grade		0%			0%			0%			0%	
Volume (veh/h)	0	110	70	0	0	0	0	0	0	177	694	0
Peak Hour Factor	0.92	0.92	0.92	0.92	0.92	0.92	0.92	0.92	0.92	0.92	0.92	0.92
Hourly flow rate (vph)	0	120	76	0	0	0	0	0	0	192	754	0
Pedestrians		237			173			25			32	
Lane Width (m)		3.5			0.0			0.0			3.5	
Walking Speed (m/s)		1.2			1.2			1.2			1.2	
Percent Blockage		19			0			0			3	
Right turn flare (veh)			2									
Median type		None			None							
Median storage veh												
Upstream signal (m)											82	
pX, platoon unblocked												
vC, conflicting volume	1408	1549	451	869	1549	205	991			173		
vC1, stage 1 conf vol												
vC2, stage 2 conf vol												
vCu, unblocked vol	1408	1549	451	869	1549	205	991			173		
tC, single (s)	7.5	6.5	6.9	7.5	6.5	6.9	4.1			4.1		
tC, 2 stage (s)												
tF (s)	3.5	4.0	3.3	3.5	4.0	3.3	2.2			2.2		
p0 queue free %	100	0	83	0	100	100	100			86		
cM capacity (veh/h)	59	79	449	0	79	781	560			1401		
<b>Direction, Lane #</b>	<b>EB 1</b>	<b>SB 1</b>	<b>SB 2</b>	<b>SB 3</b>	<b>SB 4</b>							
Volume Total	196	300	216	216	216							
Volume Left	0	192	0	0	0							
Volume Right	76	0	0	0	0							
cSH	118	1401	1700	1700	1700							
Volume to Capacity	1.66	0.14	0.13	0.13	0.13							
Queue Length 95th (m)	111.9	3.6	0.0	0.0	0.0							
Control Delay (s)	397.0	5.5	0.0	0.0	0.0							
Lane LOS	F	A										
Approach Delay (s)	397.0	1.8										
Approach LOS	F											
<b>Intersection Summary</b>												
Average Delay			69.4									
Intersection Capacity Utilization			44.1%	ICU Level of Service	A							
Analysis Period (min)			15									

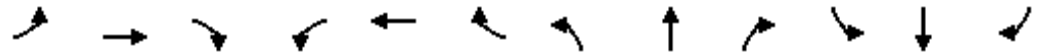

Lane Group	EBL	EBT	EBR	WBL	WBT	WBR	NBL	NBT	NBR	SBL	SBT	SBR
Lane Configurations					↑	↗		↖↖↖				
Ideal Flow (vphpl)	1750	1750	1750	1750	1750	1750	1750	1750	1750	1750	1750	1750
Storage Length (m)	0.0		0.0	0.0		15.0	0.0		0.0	0.0		0.0
Storage Lanes	0		0	0		1	0		0	0		0
Total Lost Time (s)	4.0	4.0	4.0	4.0	4.0	4.0	4.0	4.0	4.0	4.0	4.0	4.0
Turning Speed (k/h)	24		14	24		14	24		14	24		14
Lane Util. Factor	1.00	1.00	1.00	1.00	1.00	1.00	0.91	0.91	1.00	1.00	1.00	1.00
Ped Bike Factor						0.87		0.95				
Frt						0.850						
Flt Protected								0.983				
Satd. Flow (prot)	0	0	0	0	1697	1442	0	4553	0	0	0	0
Flt Permitted								0.983				
Satd. Flow (perm)	0	0	0	0	1697	1259	0	4339	0	0	0	0
Right Turn on Red			Yes			Yes	Yes		Yes			Yes
Satd. Flow (RTOR)						65		254				
Headway Factor	1.01	1.01	1.01	1.01	1.01	1.01	1.01	1.01	1.01	1.01	1.01	1.01
Link Speed (k/h)		50			50			50			50	
Link Distance (m)		182.2			96.8			83.3			76.7	
Travel Time (s)		13.1			7.0			6.0			5.5	
Volume (vph)	0	0	0	0	141	60	273	510	0	0	0	0
Confl. Peds. (#/hr)	54		59	59		54	112		267	267		112
Confl. Bikes (#/hr)						60						9
Peak Hour Factor	0.92	0.92	0.92	0.92	0.92	0.92	0.92	0.92	0.92	0.92	0.92	0.92
Adj. Flow (vph)	0	0	0	0	153	65	297	554	0	0	0	0
Lane Group Flow (vph)	0	0	0	0	153	65	0	851	0	0	0	0
Turn Type						Perm	Perm					
Protected Phases					8			2				
Permitted Phases						8	2					
Minimum Split (s)					19.0	19.0	30.0	30.0				
Total Split (s)	0.0	0.0	0.0	0.0	19.0	19.0	41.0	41.0	0.0	0.0	0.0	0.0
Total Split (%)	0.0%	0.0%	0.0%	0.0%	31.7%	31.7%	68.3%	68.3%	0.0%	0.0%	0.0%	0.0%
Maximum Green (s)					14.0	14.0	36.0	36.0				
Yellow Time (s)					3.3	3.3	3.3	3.3				
All-Red Time (s)					1.7	1.7	1.7	1.7				
Lead/Lag												
Lead-Lag Optimize?												
Walk Time (s)					7.0	7.0	19.0	19.0				
Flash Dont Walk (s)					7.0	7.0	6.0	6.0				
Pedestrian Calls (#/hr)					20	20	40	40				
Act Effct Green (s)					15.0	15.0		37.0				
Actuated g/C Ratio					0.25	0.25		0.62				
v/c Ratio					0.36	0.18		0.31				
Control Delay					21.5	7.0		4.0				
Queue Delay					0.0	0.0		0.0				
Total Delay					21.5	7.0		4.0				
LOS					C	A		A				
Approach Delay					17.2			4.0				
Approach LOS					B			A				

Intersection Summary

Area Type:	Other
Cycle Length:	60
Actuated Cycle Length:	60
Offset:	33 (55%), Referenced to phase 2:NBTL and 6:., Start of Green
Natural Cycle:	50
Control Type:	Pretimed
Maximum v/c Ratio:	0.36
Intersection Signal Delay:	6.7
Intersection LOS:	A
Intersection Capacity Utilization	39.2%
ICU Level of Service	A
Analysis Period (min)	15

Splits and Phases: 15: Gloucester & Metcalfe

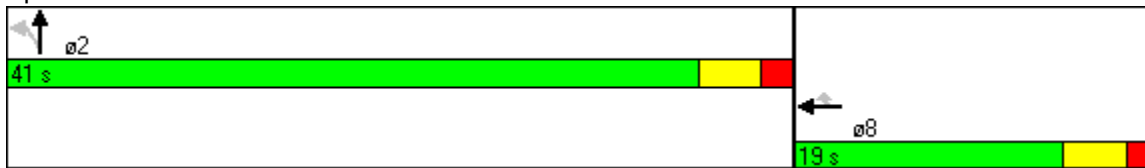



Lane Group	EBL	EBT	EBR	WBL	WBT	WBR	NBL	NBT	NBR	SBL	SBT	SBR
Lane Configurations				↙	↘						↑↑↑	
Ideal Flow (vphpl)	1750	1750	1750	1750	1750	1750	1750	1750	1750	1750	1750	1750
Storage Length (m)	0.0		0.0	15.0		0.0	0.0		0.0	0.0		0.0
Storage Lanes	0		0	1		0	0		0	0		0
Total Lost Time (s)	4.0	4.0	4.0	4.0	4.0	4.0	4.0	4.0	4.0	4.0	4.0	4.0
Turning Speed (k/h)	24		14	24		14	24		14	24		14
Lane Util. Factor	1.00	1.00	1.00	1.00	1.00	1.00	1.00	1.00	1.00	1.00	0.86	0.86
Ped Bike Factor				0.96							0.95	
Frt											0.962	
Flt Protected				0.950								
Satd. Flow (prot)	0	0	0	1612	1697	0	0	0	0	0	5359	0
Flt Permitted				0.950								
Satd. Flow (perm)	0	0	0	1540	1697	0	0	0	0	0	5359	0
Right Turn on Red			Yes	Yes		Yes			Yes			Yes
Satd. Flow (RTOR)				131							104	
Headway Factor	1.01	1.01	1.01	1.01	1.01	1.01	1.01	1.01	1.01	1.01	1.01	1.01
Link Speed (k/h)		50			50			50			50	
Link Distance (m)		108.3			182.2			82.4			78.3	
Travel Time (s)		7.8			13.1			5.9			5.6	
Volume (vph)	0	0	0	202	183	0	0	0	0	0	500	171
Confl. Peds. (#/hr)	198		37	37		198	105		138	138		105
Confl. Bikes (#/hr)			34			1						29
Peak Hour Factor	0.92	0.92	0.92	0.92	0.92	0.92	0.92	0.92	0.92	0.92	0.92	0.92
Adj. Flow (vph)	0	0	0	220	199	0	0	0	0	0	543	186
Lane Group Flow (vph)	0	0	0	220	199	0	0	0	0	0	729	0
Turn Type				Perm								
Protected Phases					8						6	
Permitted Phases				8								
Minimum Split (s)				25.0	25.0						35.0	
Total Split (s)	0.0	0.0	0.0	25.0	25.0	0.0	0.0	0.0	0.0	0.0	35.0	0.0
Total Split (%)	0.0%	0.0%	0.0%	41.7%	41.7%	0.0%	0.0%	0.0%	0.0%	0.0%	58.3%	0.0%
Maximum Green (s)				19.7	19.7						29.9	
Yellow Time (s)				3.3	3.3						3.3	
All-Red Time (s)				2.0	2.0						1.8	
Lead/Lag												
Lead-Lag Optimize?												
Walk Time (s)				7.0	7.0						15.0	
Flash Dont Walk (s)				8.0	8.0						7.0	
Pedestrian Calls (#/hr)				20	20						40	
Act Effct Green (s)				21.0	21.0						31.0	
Actuated g/C Ratio				0.35	0.35						0.52	
v/c Ratio				0.35	0.34						0.26	
Control Delay				5.3	12.8						7.1	
Queue Delay				0.0	0.0						0.0	
Total Delay				5.3	12.8						7.1	
LOS				A	B						A	
Approach Delay					8.9						7.1	
Approach LOS					A						A	

Intersection Summary

Area Type:	Other
Cycle Length:	60
Actuated Cycle Length:	60
Offset:	1 (2%), Referenced to phase 2: and 6:SBT, Start of Green
Natural Cycle:	60
Control Type:	Pretimed
Maximum v/c Ratio:	0.35
Intersection Signal Delay:	7.8
Intersection LOS:	A
Intersection Capacity Utilization	39.2%
ICU Level of Service	A
Analysis Period (min)	15

Splits and Phases: 16: Gloucester & O'Connor







Movement	EBL	EBT	EBR	WBL	WBT	WBR	NBL	NBT	NBR	SBL	SBT	SBR
Lane Configurations	↘	↑						↑↑↑				
Sign Control		Stop			Stop			Free			Free	
Grade		0%			0%			0%			0%	
Volume (veh/h)	167	149	0	0	0	0	0	490	237	0	0	0
Peak Hour Factor	0.92	0.92	0.92	0.92	0.92	0.92	0.92	0.92	0.92	0.92	0.92	0.92
Hourly flow rate (vph)	182	162	0	0	0	0	0	533	258	0	0	0
Pedestrians		232			146			40			40	
Lane Width (m)		3.5			0.0			3.5			0.0	
Walking Speed (m/s)		1.2			1.2			1.2			1.2	
Percent Blockage		19			0			3			0	
Right turn flare (veh)												
Median type		None			None							
Median storage veh												
Upstream signal (m)											83	
pX, platoon unblocked												
vC, conflicting volume	450	1168	272	928	1039	492	232			936		
vC1, stage 1 conf vol												
vC2, stage 2 conf vol												
vCu, unblocked vol	450	1168	272	928	1039	492	232			936		
tC, single (s)	7.5	6.5	6.9	7.5	6.5	6.9	4.1			4.1		
tC, 2 stage (s)												
tF (s)	3.5	4.0	3.3	3.5	4.0	3.3	2.2			2.2		
p0 queue free %	47	0	100	0	100	100	100			100		
cM capacity (veh/h)	342	156	570	0	186	522	1082			727		
<b>Direction, Lane #</b>	<b>EB 1</b>	<b>EB 2</b>	<b>NB 1</b>	<b>NB 2</b>	<b>NB 3</b>							
Volume Total	182	162	213	213	364							
Volume Left	182	0	0	0	0							
Volume Right	0	0	0	0	258							
cSH	342	156	1700	1700	1700							
Volume to Capacity	0.53	1.04	0.13	0.13	0.21							
Queue Length 95th (m)	22.4	62.2	0.0	0.0	0.0							
Control Delay (s)	26.8	141.1	0.0	0.0	0.0							
Lane LOS	D	F										
Approach Delay (s)	80.7		0.0									
Approach LOS	F											
<b>Intersection Summary</b>												
Average Delay			24.4									
Intersection Capacity Utilization			67.4%	ICU Level of Service	C							
Analysis Period (min)			15									



Movement	EBL	EBT	EBR	WBL	WBT	WBR	NBL	NBT	NBR	SBL	SBT	SBR
Lane Configurations		↑	↗								↑↑↑	
Sign Control		Stop			Stop			Free			Free	
Grade		0%			0%			0%			0%	
Volume (veh/h)	0	127	141	0	0	0	0	0	0	195	1154	0
Peak Hour Factor	0.92	0.92	0.92	0.92	0.92	0.92	0.92	0.92	0.92	0.92	0.92	0.92
Hourly flow rate (vph)	0	138	153	0	0	0	0	0	0	212	1254	0
Pedestrians		186			108			19			13	
Lane Width (m)		3.5			0.0			0.0			3.5	
Walking Speed (m/s)		1.2			1.2			1.2			1.2	
Percent Blockage		15			0			0			1	
Right turn flare (veh)			2									
Median type		None			None							
Median storage veh												
Upstream signal (m)											82	
pX, platoon unblocked	0.94	0.94	0.94	0.94	0.94		0.94					
vC, conflicting volume	1877	1972	519	1010	1972	121	1440			108		
vC1, stage 1 conf vol												
vC2, stage 2 conf vol												
vCu, unblocked vol	1743	1844	298	820	1844	121	1278			108		
tC, single (s)	7.5	6.5	6.9	7.5	6.5	6.9	4.1			4.1		
tC, 2 stage (s)												
tF (s)	3.5	4.0	3.3	3.5	4.0	3.3	2.2			2.2		
p0 queue free %	100	0	73	0	100	100	100			86		
cM capacity (veh/h)	35	51	558	0	51	898	431			1480		
<b>Direction, Lane #</b>	<b>EB 1</b>	<b>SB 1</b>	<b>SB 2</b>	<b>SB 3</b>	<b>SB 4</b>							
Volume Total	291	391	358	358	358							
Volume Left	0	212	0	0	0							
Volume Right	153	0	0	0	0							
cSH	98	1480	1700	1700	1700							
Volume to Capacity	2.98	0.14	0.21	0.21	0.21							
Queue Length 95th (m)	213.4	3.8	0.0	0.0	0.0							
Control Delay (s)	983.7	4.8	0.0	0.0	0.0							
Lane LOS	F	A										
Approach Delay (s)	983.7	1.3										
Approach LOS	F											
<b>Intersection Summary</b>												
Average Delay			164.1									
Intersection Capacity Utilization			40.3%	ICU Level of Service								A
Analysis Period (min)			15									



Lane Group	EBL	EBT	EBR	WBL	WBT	WBR	NBL	NBT	NBR	SBL	SBT	SBR
Lane Configurations					↑	↗		↖↖↖				
Ideal Flow (vphpl)	1750	1750	1750	1750	1750	1750	1750	1750	1750	1750	1750	1750
Storage Length (m)	0.0		0.0	0.0		15.0	0.0		0.0	0.0		0.0
Storage Lanes	0		0	0		1	0		0	0		0
Total Lost Time (s)	4.0	4.0	4.0	4.0	4.0	4.0	4.0	4.0	4.0	4.0	4.0	4.0
Turning Speed (k/h)	24		14	24		14	24		14	24		14
Lane Util. Factor	1.00	1.00	1.00	1.00	1.00	1.00	0.91	0.91	1.00	1.00	1.00	1.00
Ped Bike Factor						0.92		0.91				
Frt						0.850						
Flt Protected								0.984				
Satd. Flow (prot)	0	0	0	0	1697	1442	0	4558	0	0	0	0
Flt Permitted								0.984				
Satd. Flow (perm)	0	0	0	0	1697	1325	0	4144	0	0	0	0
Right Turn on Red			Yes			Yes	Yes		Yes			Yes
Satd. Flow (RTOR)						109		140				
Headway Factor	1.01	1.01	1.01	1.01	1.01	1.01	1.01	1.01	1.01	1.01	1.01	1.01
Link Speed (k/h)		50			50			50			50	
Link Distance (m)		182.2			96.8			83.3			76.7	
Travel Time (s)		13.1			7.0			6.0			5.5	
Volume (vph)	0	0	0	0	204	100	195	401	0	0	0	0
Confl. Peds. (#/hr)	46		78	78		46	231		303	303		231
Confl. Bikes (#/hr)						14						2
Peak Hour Factor	0.92	0.92	0.92	0.92	0.92	0.92	0.92	0.92	0.92	0.92	0.92	0.92
Adj. Flow (vph)	0	0	0	0	222	109	212	436	0	0	0	0
Lane Group Flow (vph)	0	0	0	0	222	109	0	648	0	0	0	0
Turn Type						Perm	Perm					
Protected Phases					8			2				
Permitted Phases						8	2					
Minimum Split (s)					19.0	19.0	30.0	30.0				
Total Split (s)	0.0	0.0	0.0	0.0	19.0	19.0	41.0	41.0	0.0	0.0	0.0	0.0
Total Split (%)	0.0%	0.0%	0.0%	0.0%	31.7%	31.7%	68.3%	68.3%	0.0%	0.0%	0.0%	0.0%
Maximum Green (s)					14.0	14.0	36.0	36.0				
Yellow Time (s)					3.3	3.3	3.3	3.3				
All-Red Time (s)					1.7	1.7	1.7	1.7				
Lead/Lag												
Lead-Lag Optimize?												
Walk Time (s)					7.0	7.0	19.0	19.0				
Flash Dont Walk (s)					7.0	7.0	6.0	6.0				
Pedestrian Calls (#/hr)					20	20	40	40				
Act Effct Green (s)					15.0	15.0		37.0				
Actuated g/C Ratio					0.25	0.25		0.62				
v/c Ratio					0.52	0.26		0.25				
Control Delay					24.7	6.4		4.3				
Queue Delay					0.0	0.0		0.0				
Total Delay					24.7	6.4		4.3				
LOS					C	A		A				
Approach Delay					18.7			4.3				
Approach LOS					B			A				

Intersection Summary

Area Type:	Other		
Cycle Length:	60		
Actuated Cycle Length:	60		
Offset:	33 (55%), Referenced to phase 2:NBTL and 6:., Start of Green		
Natural Cycle:	50		
Control Type:	Pretimed		
Maximum v/c Ratio:	0.52		
Intersection Signal Delay:	9.1	Intersection LOS:	A
Intersection Capacity Utilization	39.2%	ICU Level of Service	A
Analysis Period (min)	15		

Splits and Phases: 15: Gloucester & Metcalfe

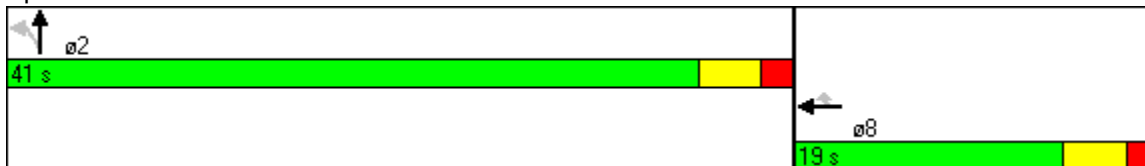



Lane Group	EBL	EBT	EBR	WBL	WBT	WBR	NBL	NBT	NBR	SBL	SBT	SBR
Lane Configurations				↙	↘						↑↑↑	
Ideal Flow (vphpl)	1750	1750	1750	1750	1750	1750	1750	1750	1750	1750	1750	1750
Storage Length (m)	0.0		0.0	15.0		0.0	0.0		0.0	0.0		0.0
Storage Lanes	0		0	1		0	0		0	0		0
Total Lost Time (s)	4.0	4.0	4.0	4.0	4.0	4.0	4.0	4.0	4.0	4.0	4.0	4.0
Turning Speed (k/h)	24		14	24		14	24		14	24		14
Lane Util. Factor	1.00	1.00	1.00	1.00	1.00	1.00	1.00	1.00	1.00	1.00	0.86	0.86
Ped Bike Factor				0.93							0.97	
Frt											0.984	
Flt Protected				0.950								
Satd. Flow (prot)	0	0	0	1612	1697	0	0	0	0	0	5591	0
Flt Permitted				0.950								
Satd. Flow (perm)	0	0	0	1493	1697	0	0	0	0	0	5591	0
Right Turn on Red			Yes	Yes		Yes			Yes			Yes
Satd. Flow (RTOR)				46							76	
Headway Factor	1.01	1.01	1.01	1.01	1.01	1.01	1.01	1.01	1.01	1.01	1.01	1.01
Link Speed (k/h)		50			50			50			50	
Link Distance (m)		108.3			182.2			82.4			78.3	
Travel Time (s)		7.8			13.1			5.9			5.6	
Volume (vph)	0	0	0	288	203	0	0	0	0	0	890	108
Confl. Peds. (#/hr)	197		67	67		197	176		90	90		176
Confl. Bikes (#/hr)			66									17
Peak Hour Factor	0.92	0.92	0.92	0.92	0.92	0.92	0.92	0.92	0.92	0.92	0.92	0.92
Adj. Flow (vph)	0	0	0	313	221	0	0	0	0	0	967	117
Lane Group Flow (vph)	0	0	0	313	221	0	0	0	0	0	1084	0
Turn Type				Perm								
Protected Phases					8						6	
Permitted Phases				8								
Minimum Split (s)				20.3	20.3						27.1	
Total Split (s)	0.0	0.0	0.0	24.0	24.0	0.0	0.0	0.0	0.0	0.0	31.0	0.0
Total Split (%)	0.0%	0.0%	0.0%	43.6%	43.6%	0.0%	0.0%	0.0%	0.0%	0.0%	56.4%	0.0%
Maximum Green (s)				18.7	18.7						25.9	
Yellow Time (s)				3.3	3.3						3.3	
All-Red Time (s)				2.0	2.0						1.8	
Lead/Lag												
Lead-Lag Optimize?												
Walk Time (s)				7.0	7.0						15.0	
Flash Dont Walk (s)				8.0	8.0						7.0	
Pedestrian Calls (#/hr)				20	20						40	
Act Effct Green (s)				20.0	20.0						27.0	
Actuated g/C Ratio				0.36	0.36						0.49	
v/c Ratio				0.55	0.36						0.39	
Control Delay				16.1	14.9						8.6	
Queue Delay				0.0	0.0						0.0	
Total Delay				16.1	14.9						8.6	
LOS				B	B						A	
Approach Delay					15.6						8.6	
Approach LOS					B						A	

Intersection Summary

Area Type:	Other		
Cycle Length:	55		
Actuated Cycle Length:	55		
Offset:	13 (24%), Referenced to phase 2: and 6:SBT, Start of Green		
Natural Cycle:	50		
Control Type:	Pretimed		
Maximum v/c Ratio:	0.55		
Intersection Signal Delay:	10.9	Intersection LOS:	B
Intersection Capacity Utilization	42.3%	ICU Level of Service	A
Analysis Period (min)	15		

Splits and Phases: 16: Gloucester & O'Connor





Lane Group	EBL	EBT	EBR	WBL	WBT	WBR	NBL	NBT	NBR	SBL	SBT	SBR
Lane Configurations												
Ideal Flow (vphpl)	1750	1750	1750	1750	1750	1750	1750	1750	1750	1750	1750	1750
Storage Length (m)	15.0		0.0	0.0		0.0	0.0		0.0	0.0		0.0
Storage Lanes	1		0	0		0	0		0	0		0
Total Lost Time (s)	4.0	4.0	4.0	4.0	4.0	4.0	4.0	4.0	4.0	4.0	4.0	4.0
Turning Speed (k/h)	24		14	24		14	24		14	24		14
Lane Util. Factor	1.00	1.00	1.00	1.00	1.00	1.00	1.00	0.91	0.91	1.00	1.00	1.00
Ped Bike Factor	0.95							0.94				
Frt								0.968				
Flt Protected	0.950											
Satd. Flow (prot)	1612	1697	0	0	0	0	0	4201	0	0	0	0
Flt Permitted	0.950											
Satd. Flow (perm)	1529	1697	0	0	0	0	0	4201	0	0	0	0
Right Turn on Red	Yes		Yes			Yes			Yes			Yes
Satd. Flow (RTOR)	15							175				
Headway Factor	1.01	1.01	1.01	1.01	1.01	1.01	1.01	1.01	1.01	1.01	1.01	1.01
Link Speed (k/h)		50			50			50				50
Link Distance (m)		182.6			94.2			73.5				83.3
Travel Time (s)		13.1			6.8			5.3				6.0
Volume (vph)	141	125	0	0	0	0	0	913	248	0	0	0
Confl. Peds. (#/hr)	40		40	40		40	330		225	225		330
Confl. Bikes (#/hr)						78			19			
Peak Hour Factor	0.92	0.92	0.92	0.92	0.92	0.92	0.92	0.92	0.92	0.92	0.92	0.92
Adj. Flow (vph)	153	136	0	0	0	0	0	992	270	0	0	0
Lane Group Flow (vph)	153	136	0	0	0	0	0	1262	0	0	0	0
Turn Type	Perm											
Protected Phases		4						2				
Permitted Phases	4											
Minimum Split (s)	23.0	23.0						35.0				
Total Split (s)	24.0	24.0	0.0	0.0	0.0	0.0	0.0	36.0	0.0	0.0	0.0	0.0
Total Split (%)	40.0%	40.0%	0.0%	0.0%	0.0%	0.0%	0.0%	60.0%	0.0%	0.0%	0.0%	0.0%
Maximum Green (s)	19.0	19.0						31.0				
Yellow Time (s)	3.3	3.3						3.3				
All-Red Time (s)	1.7	1.7						1.7				
Lead/Lag												
Lead-Lag Optimize?												
Walk Time (s)	7.0	7.0						19.0				
Flash Dont Walk (s)	7.0	7.0						6.0				
Pedestrian Calls (#/hr)	0	0						0				
Act Effct Green (s)	20.0	20.0						32.0				
Actuated g/C Ratio	0.33	0.33						0.53				
v/c Ratio	0.29	0.24						0.54				
Control Delay	18.6	19.3						8.8				
Queue Delay	0.0	0.0						0.0				
Total Delay	18.6	19.3						8.8				
LOS	B	B						A				
Approach Delay		18.9						8.8				
Approach LOS		B						A				

Intersection Summary

Area Type:	Other		
Cycle Length:	60		
Actuated Cycle Length:	60		
Offset:	26 (43%), Referenced to phase 2:NBT and 6:, Start of Green		
Natural Cycle:	60		
Control Type:	Pretimed		
Maximum v/c Ratio:	0.54		
Intersection Signal Delay:	10.7	Intersection LOS:	B
Intersection Capacity Utilization	72.7%	ICU Level of Service	C
Analysis Period (min)	15		

Splits and Phases: 1: Nepean & Metcalfe

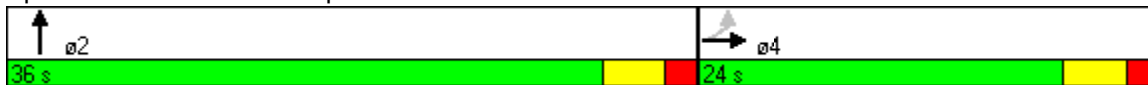



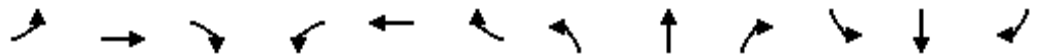

Lane Group	EBL	EBT	EBR	WBL	WBT	WBR	NBL	NBT	NBR	SBL	SBT	SBR
Lane Configurations		↑	↗								↑↑↑	
Ideal Flow (vphpl)	1750	1750	1750	1750	1750	1750	1750	1750	1750	1750	1750	1750
Storage Length (m)	0.0		15.0	0.0		0.0	0.0		0.0	0.0		0.0
Storage Lanes	0		1	0		0	0		0	0		0
Total Lost Time (s)	4.0	4.0	4.0	4.0	4.0	4.0	4.0	4.0	4.0	4.0	4.0	4.0
Turning Speed (k/h)	24		14	24		14	24		14	24		14
Lane Util. Factor	1.00	1.00	1.00	1.00	1.00	1.00	1.00	1.00	1.00	0.86	0.86	1.00
Ped Bike Factor			0.95								0.95	
Frt			0.850									
Flt Protected											0.990	
Satd. Flow (prot)	0	1697	1442	0	0	0	0	0	0	0	5778	0
Flt Permitted											0.990	
Satd. Flow (perm)	0	1697	1372	0	0	0	0	0	0	0	5501	0
Right Turn on Red			Yes			Yes			Yes	Yes		Yes
Satd. Flow (RTOR)			38								154	
Headway Factor	1.01	1.01	1.01	1.01	1.01	1.01	1.01	1.01	1.01	1.01	1.01	1.01
Link Speed (k/h)		50			50			50			50	
Link Distance (m)		109.5			182.6			73.8			82.4	
Travel Time (s)		7.9			13.1			5.3			5.9	
Volume (vph)	0	110	70	0	0	0	0	0	0	177	694	0
Confl. Peds. (#/hr)	32		25	25		32	237		173	173		237
Confl. Bikes (#/hr)			12			1			13			
Peak Hour Factor	0.92	0.92	0.92	0.92	0.92	0.92	0.92	0.92	0.92	0.92	0.92	0.92
Adj. Flow (vph)	0	120	76	0	0	0	0	0	0	192	754	0
Lane Group Flow (vph)	0	120	76	0	0	0	0	0	0	0	946	0
Turn Type			Perm							Perm		
Protected Phases		4									6	
Permitted Phases			4							6		
Minimum Split (s)		23.3	23.3							31.1	31.1	
Total Split (s)	0.0	26.0	26.0	0.0	0.0	0.0	0.0	0.0	0.0	34.0	34.0	0.0
Total Split (%)	0.0%	43.3%	43.3%	0.0%	0.0%	0.0%	0.0%	0.0%	0.0%	56.7%	56.7%	0.0%
Maximum Green (s)		20.7	20.7							28.9	28.9	
Yellow Time (s)		3.3	3.3							3.3	3.3	
All-Red Time (s)		2.0	2.0							1.8	1.8	
Lead/Lag												
Lead-Lag Optimize?												
Walk Time (s)		7.0	7.0							15.0	15.0	
Flash Dont Walk (s)		8.0	8.0							7.0	7.0	
Pedestrian Calls (#/hr)		0	0							0	0	
Act Effct Green (s)		22.0	22.0							30.0	30.0	
Actuated g/C Ratio		0.37	0.37							0.50	0.50	
v/c Ratio		0.19	0.14							0.33	0.33	
Control Delay		14.0	8.5							5.3	5.3	
Queue Delay		0.0	0.0							0.0	0.0	
Total Delay		14.0	8.5							5.3	5.3	
LOS		B	A							A	A	
Approach Delay		11.9								5.3	5.3	
Approach LOS		B								A	A	

Intersection Summary

Area Type:	Other
Cycle Length:	60
Actuated Cycle Length:	60
Offset:	7 (12%), Referenced to phase 2: and 6:SBTL, Start of Green
Natural Cycle:	55
Control Type:	Pretimed
Maximum v/c Ratio:	0.33
Intersection Signal Delay:	6.4
Intersection LOS:	A
Intersection Capacity Utilization	45.2%
ICU Level of Service	A
Analysis Period (min)	15

Splits and Phases: 13: Nepean & O'Connor





Lane Group	EBL	EBT	EBR	WBL	WBT	WBR	NBL	NBT	NBR	SBL	SBT	SBR
Lane Configurations					↑	↗		↖↖↖				
Ideal Flow (vphpl)	1750	1750	1750	1750	1750	1750	1750	1750	1750	1750	1750	1750
Storage Length (m)	0.0		0.0	0.0		15.0	0.0		0.0	0.0		0.0
Storage Lanes	0		0	0		1	0		0	0		0
Total Lost Time (s)	4.0	4.0	4.0	4.0	4.0	4.0	4.0	4.0	4.0	4.0	4.0	4.0
Turning Speed (k/h)	24		14	24		14	24		14	24		14
Lane Util. Factor	1.00	1.00	1.00	1.00	1.00	1.00	0.91	0.91	1.00	1.00	1.00	1.00
Ped Bike Factor						0.87		0.95				
Frt						0.850						
Flt Protected								0.983				
Satd. Flow (prot)	0	0	0	0	1697	1442	0	4553	0	0	0	0
Flt Permitted								0.983				
Satd. Flow (perm)	0	0	0	0	1697	1259	0	4339	0	0	0	0
Right Turn on Red			Yes			Yes	Yes		Yes			Yes
Satd. Flow (RTOR)						65		254				
Headway Factor	1.01	1.01	1.01	1.01	1.01	1.01	1.01	1.01	1.01	1.01	1.01	1.01
Link Speed (k/h)		50			50			50			50	
Link Distance (m)		182.2			96.8			83.3			76.7	
Travel Time (s)		13.1			7.0			6.0			5.5	
Volume (vph)	0	0	0	0	141	60	273	510	0	0	0	0
Confl. Peds. (#/hr)	54		59	59		54	112		267	267		112
Confl. Bikes (#/hr)						60						9
Peak Hour Factor	0.92	0.92	0.92	0.92	0.92	0.92	0.92	0.92	0.92	0.92	0.92	0.92
Adj. Flow (vph)	0	0	0	0	153	65	297	554	0	0	0	0
Lane Group Flow (vph)	0	0	0	0	153	65	0	851	0	0	0	0
Turn Type						Perm	Perm					
Protected Phases					8			2				
Permitted Phases						8	2					
Minimum Split (s)					19.0	19.0	30.0	30.0				
Total Split (s)	0.0	0.0	0.0	0.0	19.0	19.0	41.0	41.0	0.0	0.0	0.0	0.0
Total Split (%)	0.0%	0.0%	0.0%	0.0%	31.7%	31.7%	68.3%	68.3%	0.0%	0.0%	0.0%	0.0%
Maximum Green (s)					14.0	14.0	36.0	36.0				
Yellow Time (s)					3.3	3.3	3.3	3.3				
All-Red Time (s)					1.7	1.7	1.7	1.7				
Lead/Lag												
Lead-Lag Optimize?												
Walk Time (s)					7.0	7.0	19.0	19.0				
Flash Dont Walk (s)					7.0	7.0	6.0	6.0				
Pedestrian Calls (#/hr)					20	20	40	40				
Act Effct Green (s)					15.0	15.0		37.0				
Actuated g/C Ratio					0.25	0.25		0.62				
v/c Ratio					0.36	0.18		0.31				
Control Delay					21.5	7.0		1.1				
Queue Delay					0.0	0.0		0.1				
Total Delay					21.5	7.0		1.2				
LOS					C	A		A				
Approach Delay					17.2			1.2				
Approach LOS					B			A				

Intersection Summary

Area Type:	Other		
Cycle Length:	60		
Actuated Cycle Length:	60		
Offset:	33 (55%), Referenced to phase 2:NBTL and 6:., Start of Green		
Natural Cycle:	50		
Control Type:	Pretimed		
Maximum v/c Ratio:	0.36		
Intersection Signal Delay:	4.5	Intersection LOS:	A
Intersection Capacity Utilization	39.2%	ICU Level of Service	A
Analysis Period (min)	15		

Splits and Phases: 15: Gloucester & Metcalfe

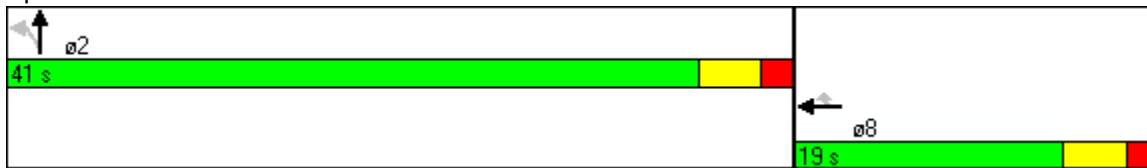



Lane Group	EBL	EBT	EBR	WBL	WBT	WBR	NBL	NBT	NBR	SBL	SBT	SBR
Lane Configurations				↙	↘						↑↑↑	
Ideal Flow (vphpl)	1750	1750	1750	1750	1750	1750	1750	1750	1750	1750	1750	1750
Storage Length (m)	0.0		0.0	15.0		0.0	0.0		0.0	0.0		0.0
Storage Lanes	0		0	1		0	0		0	0		0
Total Lost Time (s)	4.0	4.0	4.0	4.0	4.0	4.0	4.0	4.0	4.0	4.0	4.0	4.0
Turning Speed (k/h)	24		14	24		14	24		14	24		14
Lane Util. Factor	1.00	1.00	1.00	1.00	1.00	1.00	1.00	1.00	1.00	1.00	0.86	0.86
Ped Bike Factor				0.96							0.95	
Frt											0.962	
Flt Protected				0.950								
Satd. Flow (prot)	0	0	0	1612	1697	0	0	0	0	0	5359	0
Flt Permitted				0.950								
Satd. Flow (perm)	0	0	0	1540	1697	0	0	0	0	0	5359	0
Right Turn on Red			Yes	Yes		Yes			Yes			Yes
Satd. Flow (RTOR)				131							104	
Headway Factor	1.01	1.01	1.01	1.01	1.01	1.01	1.01	1.01	1.01	1.01	1.01	1.01
Link Speed (k/h)		50			50			50			50	
Link Distance (m)		108.3			182.2			82.4			78.3	
Travel Time (s)		7.8			13.1			5.9			5.6	
Volume (vph)	0	0	0	202	183	0	0	0	0	0	500	171
Confl. Peds. (#/hr)	198		37	37		198	105		138	138		105
Confl. Bikes (#/hr)			34			1						29
Peak Hour Factor	0.92	0.92	0.92	0.92	0.92	0.92	0.92	0.92	0.92	0.92	0.92	0.92
Adj. Flow (vph)	0	0	0	220	199	0	0	0	0	0	543	186
Lane Group Flow (vph)	0	0	0	220	199	0	0	0	0	0	729	0
Turn Type				Perm								
Protected Phases					8						6	
Permitted Phases				8								
Minimum Split (s)				25.0	25.0						35.0	
Total Split (s)	0.0	0.0	0.0	25.0	25.0	0.0	0.0	0.0	0.0	0.0	35.0	0.0
Total Split (%)	0.0%	0.0%	0.0%	41.7%	41.7%	0.0%	0.0%	0.0%	0.0%	0.0%	58.3%	0.0%
Maximum Green (s)				19.7	19.7						29.9	
Yellow Time (s)				3.3	3.3						3.3	
All-Red Time (s)				2.0	2.0						1.8	
Lead/Lag												
Lead-Lag Optimize?												
Walk Time (s)				7.0	7.0						15.0	
Flash Dont Walk (s)				8.0	8.0						7.0	
Pedestrian Calls (#/hr)				20	20						40	
Act Effct Green (s)				21.0	21.0						31.0	
Actuated g/C Ratio				0.35	0.35						0.52	
v/c Ratio				0.35	0.34						0.26	
Control Delay				5.0	12.0						7.1	
Queue Delay				0.0	0.0						0.0	
Total Delay				5.0	12.0						7.1	
LOS				A	B						A	
Approach Delay					8.4						7.1	
Approach LOS					A						A	

Intersection Summary

Area Type:	Other		
Cycle Length:	60		
Actuated Cycle Length:	60		
Offset:	1 (2%), Referenced to phase 2: and 6:SBT, Start of Green		
Natural Cycle:	60		
Control Type:	Pretimed		
Maximum v/c Ratio:	0.35		
Intersection Signal Delay:	7.6	Intersection LOS:	A
Intersection Capacity Utilization	39.2%	ICU Level of Service	A
Analysis Period (min)	15		

Splits and Phases: 16: Gloucester & O'Connor





Lane Group	EBL	EBT	EBR	WBL	WBT	WBR	NBL	NBT	NBR	SBL	SBT	SBR
Lane Configurations												
Ideal Flow (vphpl)	1750	1750	1750	1750	1750	1750	1750	1750	1750	1750	1750	1750
Storage Length (m)	15.0		0.0	0.0		0.0	0.0		0.0	0.0		0.0
Storage Lanes	1		0	0		0	0		0	0		0
Total Lost Time (s)	4.0	4.0	4.0	4.0	4.0	4.0	4.0	4.0	4.0	4.0	4.0	4.0
Turning Speed (k/h)	24		14	24		14	24		14	24		14
Lane Util. Factor	1.00	1.00	1.00	1.00	1.00	1.00	1.00	0.91	0.91	1.00	1.00	1.00
Ped Bike Factor	0.95							0.93				
Frt								0.951				
Flt Protected	0.950											
Satd. Flow (prot)	1612	1697	0	0	0	0	0	4112	0	0	0	0
Flt Permitted	0.950											
Satd. Flow (perm)	1529	1697	0	0	0	0	0	4112	0	0	0	0
Right Turn on Red	Yes		Yes			Yes			Yes			Yes
Satd. Flow (RTOR)	88							258				
Headway Factor	1.01	1.01	1.01	1.01	1.01	1.01	1.01	1.01	1.01	1.01	1.01	1.01
Link Speed (k/h)		50			50			50				50
Link Distance (m)		182.6			94.2			73.5				83.3
Travel Time (s)		13.1			6.8			5.3				6.0
Volume (vph)	167	149	0	0	0	0	0	490	237	0	0	0
Confl. Peds. (#/hr)	40		40	40		40	232		146	146		232
Confl. Bikes (#/hr)						19			21			
Peak Hour Factor	0.92	0.92	0.92	0.92	0.92	0.92	0.92	0.92	0.92	0.92	0.92	0.92
Adj. Flow (vph)	182	162	0	0	0	0	0	533	258	0	0	0
Lane Group Flow (vph)	182	162	0	0	0	0	0	791	0	0	0	0
Turn Type	Perm											
Protected Phases		4						2				
Permitted Phases	4											
Minimum Split (s)	23.0	23.0						35.0				
Total Split (s)	24.0	24.0	0.0	0.0	0.0	0.0	0.0	36.0	0.0	0.0	0.0	0.0
Total Split (%)	40.0%	40.0%	0.0%	0.0%	0.0%	0.0%	0.0%	60.0%	0.0%	0.0%	0.0%	0.0%
Maximum Green (s)	19.0	19.0						31.0				
Yellow Time (s)	3.3	3.3						3.3				
All-Red Time (s)	1.7	1.7						1.7				
Lead/Lag												
Lead-Lag Optimize?												
Walk Time (s)	7.0	7.0						19.0				
Flash Dont Walk (s)	7.0	7.0						6.0				
Pedestrian Calls (#/hr)	0	0						0				
Act Effct Green (s)	20.0	20.0						32.0				
Actuated g/C Ratio	0.33	0.33						0.53				
v/c Ratio	0.32	0.29						0.34				
Control Delay	9.9	16.5						5.6				
Queue Delay	0.0	0.0						0.0				
Total Delay	9.9	16.5						5.6				
LOS	A	B						A				
Approach Delay		13.0						5.6				
Approach LOS		B						A				

Intersection Summary

Area Type:	Other		
Cycle Length:	60		
Actuated Cycle Length:	60		
Offset:	29 (48%), Referenced to phase 2:NBT and 6:, Start of Green		
Natural Cycle:	60		
Control Type:	Pretimed		
Maximum v/c Ratio:	0.34		
Intersection Signal Delay:	7.9	Intersection LOS:	A
Intersection Capacity Utilization	69.7%	ICU Level of Service	C
Analysis Period (min)	15		

Splits and Phases: 1: Nepean & Metcalfe

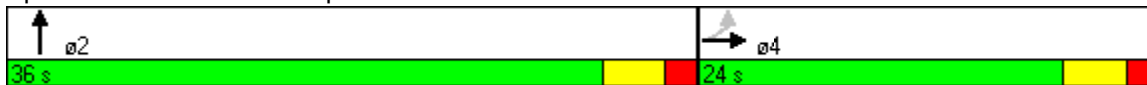





Lane Group	EBL	EBT	EBR	WBL	WBT	WBR	NBL	NBT	NBR	SBL	SBT	SBR
Lane Configurations		↑	↗								↑↑↑	
Ideal Flow (vphpl)	1750	1750	1750	1750	1750	1750	1750	1750	1750	1750	1750	1750
Storage Length (m)	0.0		15.0	0.0		0.0	0.0		0.0	0.0		0.0
Storage Lanes	0		1	0		0	0		0	0		0
Total Lost Time (s)	4.0	4.0	4.0	4.0	4.0	4.0	4.0	4.0	4.0	4.0	4.0	4.0
Turning Speed (k/h)	24		14	24		14	24		14	24		14
Lane Util. Factor	1.00	1.00	1.00	1.00	1.00	1.00	1.00	1.00	1.00	0.86	0.86	1.00
Ped Bike Factor			0.94									0.98
Frt			0.850									
Flt Protected												0.993
Satd. Flow (prot)	0	1697	1442	0	0	0	0	0	0	0	5796	0
Flt Permitted												0.993
Satd. Flow (perm)	0	1697	1360	0	0	0	0	0	0	0	5682	0
Right Turn on Red			Yes			Yes			Yes	Yes		Yes
Satd. Flow (RTOR)			11									109
Headway Factor	1.01	1.01	1.01	1.01	1.01	1.01	1.01	1.01	1.01	1.01	1.01	1.01
Link Speed (k/h)		50			50			50			50	
Link Distance (m)		109.5			182.6			73.8			82.4	
Travel Time (s)		7.9			13.1			5.3			5.9	
Volume (vph)	0	127	141	0	0	0	0	0	0	195	1154	0
Confl. Peds. (#/hr)	13		19	19		13	186		108	108		186
Confl. Bikes (#/hr)			41			1			25			
Peak Hour Factor	0.92	0.92	0.92	0.92	0.92	0.92	0.92	0.92	0.92	0.92	0.92	0.92
Adj. Flow (vph)	0	138	153	0	0	0	0	0	0	212	1254	0
Lane Group Flow (vph)	0	138	153	0	0	0	0	0	0	0	1466	0
Turn Type			Perm								Perm	
Protected Phases		4										6
Permitted Phases			4								6	
Minimum Split (s)		20.3	20.3							27.1	27.1	
Total Split (s)	0.0	24.0	24.0	0.0	0.0	0.0	0.0	0.0	0.0	31.0	31.0	0.0
Total Split (%)	0.0%	43.6%	43.6%	0.0%	0.0%	0.0%	0.0%	0.0%	0.0%	56.4%	56.4%	0.0%
Maximum Green (s)		18.7	18.7							25.9	25.9	
Yellow Time (s)		3.3	3.3							3.3	3.3	
All-Red Time (s)		2.0	2.0							1.8	1.8	
Lead/Lag												
Lead-Lag Optimize?												
Walk Time (s)		7.0	7.0							15.0	15.0	
Flash Dont Walk (s)		8.0	8.0							7.0	7.0	
Pedestrian Calls (#/hr)		0	0							0	0	
Act Effct Green (s)		20.0	20.0								27.0	
Actuated g/C Ratio		0.36	0.36								0.49	
v/c Ratio		0.22	0.30								0.52	
Control Delay		13.4	13.7								6.0	
Queue Delay		0.0	0.0								0.1	
Total Delay		13.4	13.7								6.1	
LOS		B	B								A	
Approach Delay		13.5									6.1	
Approach LOS		B									A	

Intersection Summary

Area Type:	Other		
Cycle Length:	55		
Actuated Cycle Length:	55		
Offset:	15 (27%), Referenced to phase 2: and 6:SBTL, Start of Green		
Natural Cycle:	50		
Control Type:	Pretimed		
Maximum v/c Ratio:	0.52		
Intersection Signal Delay:	7.3	Intersection LOS:	A
Intersection Capacity Utilization	40.5%	ICU Level of Service	A
Analysis Period (min)	15		

Splits and Phases: 13: Nepean & O'Connor



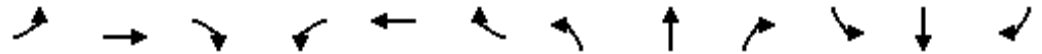

Lane Group	EBL	EBT	EBR	WBL	WBT	WBR	NBL	NBT	NBR	SBL	SBT	SBR
Lane Configurations					↑	↗		↖↖↖				
Ideal Flow (vphpl)	1750	1750	1750	1750	1750	1750	1750	1750	1750	1750	1750	1750
Storage Length (m)	0.0		0.0	0.0		15.0	0.0		0.0	0.0		0.0
Storage Lanes	0		0	0		1	0		0	0		0
Total Lost Time (s)	4.0	4.0	4.0	4.0	4.0	4.0	4.0	4.0	4.0	4.0	4.0	4.0
Turning Speed (k/h)	24		14	24		14	24		14	24		14
Lane Util. Factor	1.00	1.00	1.00	1.00	1.00	1.00	0.91	0.91	1.00	1.00	1.00	1.00
Ped Bike Factor						0.92		0.91				
Frt						0.850						
Flt Protected								0.984				
Satd. Flow (prot)	0	0	0	0	1697	1442	0	4558	0	0	0	0
Flt Permitted								0.984				
Satd. Flow (perm)	0	0	0	0	1697	1325	0	4144	0	0	0	0
Right Turn on Red			Yes			Yes	Yes		Yes			Yes
Satd. Flow (RTOR)						109		140				
Headway Factor	1.01	1.01	1.01	1.01	1.01	1.01	1.01	1.01	1.01	1.01	1.01	1.01
Link Speed (k/h)		50			50			50			50	
Link Distance (m)		182.2			96.8			83.3			76.7	
Travel Time (s)		13.1			7.0			6.0			5.5	
Volume (vph)	0	0	0	0	204	100	195	401	0	0	0	0
Confl. Peds. (#/hr)	46		78	78		46	231		303	303		231
Confl. Bikes (#/hr)						14						2
Peak Hour Factor	0.92	0.92	0.92	0.92	0.92	0.92	0.92	0.92	0.92	0.92	0.92	0.92
Adj. Flow (vph)	0	0	0	0	222	109	212	436	0	0	0	0
Lane Group Flow (vph)	0	0	0	0	222	109	0	648	0	0	0	0
Turn Type						Perm	Perm					
Protected Phases					8			2				
Permitted Phases						8	2					
Minimum Split (s)					19.0	19.0	30.0	30.0				
Total Split (s)	0.0	0.0	0.0	0.0	19.0	19.0	41.0	41.0	0.0	0.0	0.0	0.0
Total Split (%)	0.0%	0.0%	0.0%	0.0%	31.7%	31.7%	68.3%	68.3%	0.0%	0.0%	0.0%	0.0%
Maximum Green (s)					14.0	14.0	36.0	36.0				
Yellow Time (s)					3.3	3.3	3.3	3.3				
All-Red Time (s)					1.7	1.7	1.7	1.7				
Lead/Lag												
Lead-Lag Optimize?												
Walk Time (s)					7.0	7.0	19.0	19.0				
Flash Dont Walk (s)					7.0	7.0	6.0	6.0				
Pedestrian Calls (#/hr)					20	20	40	40				
Act Effct Green (s)					15.0	15.0		37.0				
Actuated g/C Ratio					0.25	0.25		0.62				
v/c Ratio					0.52	0.26		0.25				
Control Delay					24.7	6.4		3.1				
Queue Delay					0.0	0.0		0.0				
Total Delay					24.7	6.4		3.1				
LOS					C	A		A				
Approach Delay					18.7			3.1				
Approach LOS					B			A				

Intersection Summary

Area Type:	Other		
Cycle Length:	60		
Actuated Cycle Length:	60		
Offset:	35 (58%), Referenced to phase 2:NBTL and 6:., Start of Green		
Natural Cycle:	50		
Control Type:	Pretimed		
Maximum v/c Ratio:	0.52		
Intersection Signal Delay:	8.4	Intersection LOS:	A
Intersection Capacity Utilization	39.2%	ICU Level of Service	A
Analysis Period (min)	15		

Splits and Phases: 15: Gloucester & Metcalfe

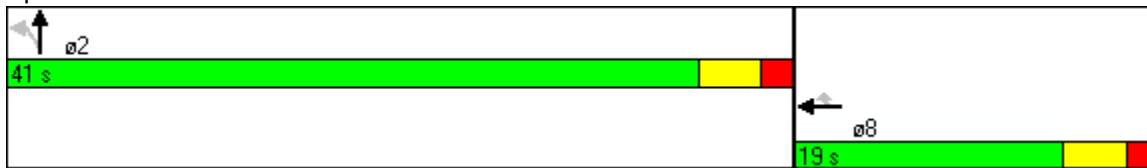



Lane Group	EBL	EBT	EBR	WBL	WBT	WBR	NBL	NBT	NBR	SBL	SBT	SBR
Lane Configurations				↙	↘						↑↑↑	
Ideal Flow (vphpl)	1750	1750	1750	1750	1750	1750	1750	1750	1750	1750	1750	1750
Storage Length (m)	0.0		0.0	15.0		0.0	0.0		0.0	0.0		0.0
Storage Lanes	0		0	1		0	0		0	0		0
Total Lost Time (s)	4.0	4.0	4.0	4.0	4.0	4.0	4.0	4.0	4.0	4.0	4.0	4.0
Turning Speed (k/h)	24		14	24		14	24		14	24		14
Lane Util. Factor	1.00	1.00	1.00	1.00	1.00	1.00	1.00	1.00	1.00	1.00	0.86	0.86
Ped Bike Factor				0.93							0.97	
Frt											0.984	
Flt Protected				0.950								
Satd. Flow (prot)	0	0	0	1612	1697	0	0	0	0	0	5591	0
Flt Permitted				0.950								
Satd. Flow (perm)	0	0	0	1493	1697	0	0	0	0	0	5591	0
Right Turn on Red			Yes	Yes		Yes			Yes			Yes
Satd. Flow (RTOR)				46							76	
Headway Factor	1.01	1.01	1.01	1.01	1.01	1.01	1.01	1.01	1.01	1.01	1.01	1.01
Link Speed (k/h)		50			50			50			50	
Link Distance (m)		108.3			182.2			82.4			78.3	
Travel Time (s)		7.8			13.1			5.9			5.6	
Volume (vph)	0	0	0	288	203	0	0	0	0	0	890	108
Confl. Peds. (#/hr)	197		67	67		197	176		90	90		176
Confl. Bikes (#/hr)			66									17
Peak Hour Factor	0.92	0.92	0.92	0.92	0.92	0.92	0.92	0.92	0.92	0.92	0.92	0.92
Adj. Flow (vph)	0	0	0	313	221	0	0	0	0	0	967	117
Lane Group Flow (vph)	0	0	0	313	221	0	0	0	0	0	1084	0
Turn Type				Perm								
Protected Phases					8						6	
Permitted Phases				8								
Minimum Split (s)				20.3	20.3						27.1	
Total Split (s)	0.0	0.0	0.0	24.0	24.0	0.0	0.0	0.0	0.0	0.0	31.0	0.0
Total Split (%)	0.0%	0.0%	0.0%	43.6%	43.6%	0.0%	0.0%	0.0%	0.0%	0.0%	56.4%	0.0%
Maximum Green (s)				18.7	18.7						25.9	
Yellow Time (s)				3.3	3.3						3.3	
All-Red Time (s)				2.0	2.0						1.8	
Lead/Lag												
Lead-Lag Optimize?												
Walk Time (s)				7.0	7.0						15.0	
Flash Dont Walk (s)				8.0	8.0						7.0	
Pedestrian Calls (#/hr)				20	20						40	
Act Effct Green (s)				20.0	20.0						27.0	
Actuated g/C Ratio				0.36	0.36						0.49	
v/c Ratio				0.55	0.36						0.39	
Control Delay				16.1	14.9						8.6	
Queue Delay				0.0	0.0						0.0	
Total Delay				16.1	14.9						8.6	
LOS				B	B						A	
Approach Delay					15.6						8.6	
Approach LOS					B						A	

Intersection Summary

Area Type:	Other		
Cycle Length:	55		
Actuated Cycle Length:	55		
Offset:	13 (24%), Referenced to phase 2: and 6:SBT, Start of Green		
Natural Cycle:	50		
Control Type:	Pretimed		
Maximum v/c Ratio:	0.55		
Intersection Signal Delay:	10.9	Intersection LOS:	B
Intersection Capacity Utilization	42.3%	ICU Level of Service	A
Analysis Period (min)	15		

Splits and Phases: 16: Gloucester & O'Connor





Movement	EBL	EBT	EBR	WBL	WBT	WBR	NBL	NBT	NBR	SBL	SBT	SBR
Lane Configurations	↘	↑						↑↑↑				
Sign Control		Stop			Stop			Free			Free	
Grade		0%			0%			0%			0%	
Volume (veh/h)	145	130	0	0	0	0	0	959	258	0	0	0
Peak Hour Factor	0.92	0.92	0.92	0.92	0.92	0.92	0.92	0.92	0.92	0.92	0.92	0.92
Hourly flow rate (vph)	158	141	0	0	0	0	0	1042	280	0	0	0
Pedestrians		330			225			40			40	
Lane Width (m)		3.5			0.0			3.5			0.0	
Walking Speed (m/s)		1.2			1.2			1.2			1.2	
Percent Blockage		27			0			3			0	
Right turn flare (veh)												
Median type		None			None							
Median storage (veh)												
Upstream signal (m)											83	
pX, platoon unblocked												
vC, conflicting volume	717	1878	370	1518	1738	753	330			1548		
vC1, stage 1 conf vol												
vC2, stage 2 conf vol												
vCu, unblocked vol	717	1878	370	1518	1738	753	330			1548		
tC, single (s)	7.5	6.5	6.9	7.5	6.5	6.9	4.1			4.1		
tC, 2 stage (s)												
tF (s)	3.5	4.0	3.3	3.5	4.0	3.3	2.2			2.2		
p0 queue free %	14	0	100	0	100	100	100			100		
cM capacity (veh/h)	184	52	445	0	63	352	898			424		

Direction, Lane #	EB 1	EB 2	NB 1	NB 2	NB 3
Volume Total	158	141	417	417	489
Volume Left	158	0	0	0	0
Volume Right	0	0	0	0	280
cSH	184	52	1700	1700	1700
Volume to Capacity	0.86	2.73	0.25	0.25	0.29
Queue Length 95th (m)	47.2	112.3	0.0	0.0	0.0
Control Delay (s)	84.8	950.8	0.0	0.0	0.0
Lane LOS	F	F			
Approach Delay (s)	494.2		0.0		
Approach LOS	F				

Intersection Summary		
Average Delay		91.1
Intersection Capacity Utilization	68.4%	ICU Level of Service C
Analysis Period (min)		15



Movement	EBL	EBT	EBR	WBL	WBT	WBR	NBL	NBT	NBR	SBL	SBT	SBR
Lane Configurations		↑	↗								↑↑↑	
Sign Control		Stop			Stop			Free			Free	
Grade		0%			0%			0%			0%	
Volume (veh/h)	0	115	74	0	0	0	0	0	0	184	728	0
Peak Hour Factor	0.92	0.92	0.92	0.92	0.92	0.92	0.92	0.92	0.92	0.92	0.92	0.92
Hourly flow rate (vph)	0	125	80	0	0	0	0	0	0	200	791	0
Pedestrians		237			173			25			32	
Lane Width (m)		3.5			0.0			0.0			3.5	
Walking Speed (m/s)		1.2			1.2			1.2			1.2	
Percent Blockage		19			0			0			3	
Right turn flare (veh)			2									
Median type		None			None							
Median storage veh												
Upstream signal (m)											82	
pX, platoon unblocked												
vC, conflicting volume	1460	1601	460	899	1601	205	1028			173		
vC1, stage 1 conf vol												
vC2, stage 2 conf vol												
vCu, unblocked vol	1460	1601	460	899	1601	205	1028			173		
tC, single (s)	7.5	6.5	6.9	7.5	6.5	6.9	4.1			4.1		
tC, 2 stage (s)												
tF (s)	3.5	4.0	3.3	3.5	4.0	3.3	2.2			2.2		
p0 queue free %	100	0	82	0	100	100	100			86		
cM capacity (veh/h)	54	73	443	0	73	781	542			1401		

Direction, Lane #	EB 1	SB 1	SB 2	SB 3	SB 4
Volume Total	205	313	226	226	226
Volume Left	0	200	0	0	0
Volume Right	80	0	0	0	0
cSH	109	1401	1700	1700	1700
Volume to Capacity	1.88	0.14	0.13	0.13	0.13
Queue Length 95th (m)	126.5	3.8	0.0	0.0	0.0
Control Delay (s)	494.6	5.6	0.0	0.0	0.0
Lane LOS	F	A			
Approach Delay (s)	494.6	1.8			
Approach LOS	F				

Intersection Summary		
Average Delay		86.4
Intersection Capacity Utilization	45.5%	ICU Level of Service
Analysis Period (min)		15
		A





Lane Group	EBL	EBT	EBR	WBL	WBT	WBR	NBL	NBT	NBR	SBL	SBT	SBR
Lane Configurations						↑	↗	↖↖↖				
Ideal Flow (vphpl)	1750	1750	1750	1750	1750	1750	1750	1750	1750	1750	1750	1750
Storage Length (m)	0.0		0.0	0.0		15.0	0.0		0.0	0.0		0.0
Storage Lanes	0		0	0		1	0		0	0		0
Total Lost Time (s)	4.0	4.0	4.0	4.0	4.0	4.0	4.0	4.0	4.0	4.0	4.0	4.0
Turning Speed (k/h)	24		14	24		14	24		14	24		14
Lane Util. Factor	1.00	1.00	1.00	1.00	1.00	1.00	0.91	0.91	1.00	1.00	1.00	1.00
Ped Bike Factor						0.87		0.95				
Frt						0.850						
Flt Protected								0.983				
Satd. Flow (prot)	0	0	0	0	1697	1442	0	4553	0	0	0	0
Flt Permitted								0.983				
Satd. Flow (perm)	0	0	0	0	1697	1259	0	4340	0	0	0	0
Right Turn on Red			Yes			Yes	Yes		Yes			Yes
Satd. Flow (RTOR)						68		244				
Headway Factor	1.01	1.01	1.01	1.01	1.01	1.01	1.01	1.01	1.01	1.01	1.01	1.01
Link Speed (k/h)		50			50			50			50	
Link Distance (m)		182.2			96.8			83.3			76.7	
Travel Time (s)		13.1			7.0			6.0			5.5	
Volume (vph)	0	0	0	0	148	63	285	534	0	0	0	0
Confl. Peds. (#/hr)	54		59	59		54	112		267	267		112
Confl. Bikes (#/hr)						60						9
Peak Hour Factor	0.92	0.92	0.92	0.92	0.92	0.92	0.92	0.92	0.92	0.92	0.92	0.92
Adj. Flow (vph)	0	0	0	0	161	68	310	580	0	0	0	0
Lane Group Flow (vph)	0	0	0	0	161	68	0	890	0	0	0	0
Turn Type						Perm	Perm					
Protected Phases					8			2				
Permitted Phases						8	2					
Minimum Split (s)					19.0	19.0	30.0	30.0				
Total Split (s)	0.0	0.0	0.0	0.0	19.0	19.0	41.0	41.0	0.0	0.0	0.0	0.0
Total Split (%)	0.0%	0.0%	0.0%	0.0%	31.7%	31.7%	68.3%	68.3%	0.0%	0.0%	0.0%	0.0%
Maximum Green (s)					14.0	14.0	36.0	36.0				
Yellow Time (s)					3.3	3.3	3.3	3.3				
All-Red Time (s)					1.7	1.7	1.7	1.7				
Lead/Lag												
Lead-Lag Optimize?												
Walk Time (s)					7.0	7.0	19.0	19.0				
Flash Dont Walk (s)					7.0	7.0	6.0	6.0				
Pedestrian Calls (#/hr)					20	20	40	40				
Act Effct Green (s)					15.0	15.0		37.0				
Actuated g/C Ratio					0.25	0.25		0.62				
v/c Ratio					0.38	0.19		0.32				
Control Delay					21.8	7.0		4.2				
Queue Delay					0.0	0.0		0.0				
Total Delay					21.8	7.0		4.2				
LOS					C	A		A				
Approach Delay					17.4			4.2				
Approach LOS					B			A				

Intersection Summary

Area Type:	Other
Cycle Length:	60
Actuated Cycle Length:	60
Offset:	33 (55%), Referenced to phase 2:NBTL and 6:., Start of Green
Natural Cycle:	50
Control Type:	Pretimed
Maximum v/c Ratio:	0.38
Intersection Signal Delay:	6.9
Intersection LOS:	A
Intersection Capacity Utilization	39.2%
ICU Level of Service	A
Analysis Period (min)	15

Splits and Phases: 15: Gloucester & Metcalfe

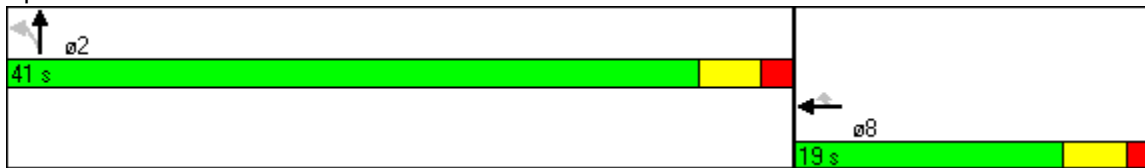



Lane Group	EBL	EBT	EBR	WBL	WBT	WBR	NBL	NBT	NBR	SBL	SBT	SBR
Lane Configurations				↙	↘						↑↑↑	
Ideal Flow (vphpl)	1750	1750	1750	1750	1750	1750	1750	1750	1750	1750	1750	1750
Storage Length (m)	0.0		0.0	15.0		0.0	0.0		0.0	0.0		0.0
Storage Lanes	0		0	1		0	0		0	0		0
Total Lost Time (s)	4.0	4.0	4.0	4.0	4.0	4.0	4.0	4.0	4.0	4.0	4.0	4.0
Turning Speed (k/h)	24		14	24		14	24		14	24		14
Lane Util. Factor	1.00	1.00	1.00	1.00	1.00	1.00	1.00	1.00	1.00	1.00	0.86	0.86
Ped Bike Factor				0.96							0.95	
Frt											0.962	
Flt Protected				0.950								
Satd. Flow (prot)	0	0	0	1612	1697	0	0	0	0	0	5359	0
Flt Permitted				0.950								
Satd. Flow (perm)	0	0	0	1540	1697	0	0	0	0	0	5359	0
Right Turn on Red			Yes	Yes		Yes			Yes			Yes
Satd. Flow (RTOR)				122							100	
Headway Factor	1.01	1.01	1.01	1.01	1.01	1.01	1.01	1.01	1.01	1.01	1.01	1.01
Link Speed (k/h)		50			50			50			50	
Link Distance (m)		108.3			182.2			82.4			78.3	
Travel Time (s)		7.8			13.1			5.9			5.6	
Volume (vph)	0	0	0	209	191	0	0	0	0	0	526	180
Confl. Peds. (#/hr)	198		37	37		198	105		138	138		105
Confl. Bikes (#/hr)			34			1						29
Peak Hour Factor	0.92	0.92	0.92	0.92	0.92	0.92	0.92	0.92	0.92	0.92	0.92	0.92
Adj. Flow (vph)	0	0	0	227	208	0	0	0	0	0	572	196
Lane Group Flow (vph)	0	0	0	227	208	0	0	0	0	0	768	0
Turn Type				Perm								
Protected Phases					8						6	
Permitted Phases				8								
Minimum Split (s)				25.0	25.0						35.0	
Total Split (s)	0.0	0.0	0.0	25.0	25.0	0.0	0.0	0.0	0.0	0.0	35.0	0.0
Total Split (%)	0.0%	0.0%	0.0%	41.7%	41.7%	0.0%	0.0%	0.0%	0.0%	0.0%	58.3%	0.0%
Maximum Green (s)				19.7	19.7						29.9	
Yellow Time (s)				3.3	3.3						3.3	
All-Red Time (s)				2.0	2.0						1.8	
Lead/Lag												
Lead-Lag Optimize?												
Walk Time (s)				7.0	7.0						15.0	
Flash Dont Walk (s)				8.0	8.0						7.0	
Pedestrian Calls (#/hr)				20	20						40	
Act Effct Green (s)				21.0	21.0						31.0	
Actuated g/C Ratio				0.35	0.35						0.52	
v/c Ratio				0.37	0.35						0.27	
Control Delay				5.9	12.9						7.3	
Queue Delay				0.0	0.0						0.0	
Total Delay				5.9	12.9						7.3	
LOS				A	B						A	
Approach Delay					9.3						7.3	
Approach LOS					A						A	

Intersection Summary

Area Type:	Other		
Cycle Length:	60		
Actuated Cycle Length:	60		
Offset:	1 (2%), Referenced to phase 2: and 6:SBT, Start of Green		
Natural Cycle:	60		
Control Type:	Pretimed		
Maximum v/c Ratio:	0.37		
Intersection Signal Delay:	8.0	Intersection LOS:	A
Intersection Capacity Utilization	39.2%	ICU Level of Service	A
Analysis Period (min)	15		

Splits and Phases: 16: Gloucester & O'Connor





Movement	EBL	EBT	EBR	WBL	WBT	WBR	NBL	NBT	NBR	SBL	SBT	SBR
Lane Configurations	↘	↑						↑↑↑				
Sign Control	Stop		Stop				Free			Free		
Grade	0%		0%				0%			0%		
Volume (veh/h)	173	155	0	0	0	0	0	514	242	0	0	0
Peak Hour Factor	0.92	0.92	0.92	0.92	0.92	0.92	0.92	0.92	0.92	0.92	0.92	0.92
Hourly flow rate (vph)	188	168	0	0	0	0	0	559	263	0	0	0
Pedestrians	232		146				40			40		
Lane Width (m)	3.5		0.0				3.5			0.0		
Walking Speed (m/s)	1.2		1.2				1.2			1.2		
Percent Blockage	19		0				3			0		
Right turn flare (veh)												
Median type	None				None							
Median storage veh												
Upstream signal (m)												83
pX, platoon unblocked												
vC, conflicting volume	458	1200	272	960	1068	504	232				968	
vC1, stage 1 conf vol												
vC2, stage 2 conf vol												
vCu, unblocked vol	458	1200	272	960	1068	504	232				968	
tC, single (s)	7.5	6.5	6.9	7.5	6.5	6.9	4.1				4.1	
tC, 2 stage (s)												
tF (s)	3.5	4.0	3.3	3.5	4.0	3.3	2.2				2.2	
p0 queue free %	44	0	100	0	100	100	100				100	
cM capacity (veh/h)	338	149	570	0	179	513	1082				708	
<b>Direction, Lane #</b>	<b>EB 1</b>	<b>EB 2</b>	<b>NB 1</b>	<b>NB 2</b>	<b>NB 3</b>							
Volume Total	188	168	223	223	375							
Volume Left	188	0	0	0	0							
Volume Right	0	0	0	0	263							
cSH	338	149	1700	1700	1700							
Volume to Capacity	0.56	1.13	0.13	0.13	0.22							
Queue Length 95th (m)	24.5	70.2	0.0	0.0	0.0							
Control Delay (s)	28.3	172.4	0.0	0.0	0.0							
Lane LOS	D	F										
Approach Delay (s)	96.4	0.0										
Approach LOS	F											
<b>Intersection Summary</b>												
Average Delay	29.2											
Intersection Capacity Utilization	69.3%		ICU Level of Service				C					
Analysis Period (min)	15											



Movement	EBL	EBT	EBR	WBL	WBT	WBR	NBL	NBT	NBR	SBL	SBT	SBR	
Lane Configurations		↑	↗								↑↑↑		
Sign Control		Stop			Stop			Free			Free		
Grade		0%			0%			0%			0%		
Volume (veh/h)	0	132	148	0	0	0	0	0	0	202	1212	0	
Peak Hour Factor	0.92	0.92	0.92	0.92	0.92	0.92	0.92	0.92	0.92	0.92	0.92	0.92	
Hourly flow rate (vph)	0	143	161	0	0	0	0	0	0	220	1317	0	
Pedestrians		186			108			19			13		
Lane Width (m)		3.5			0.0			0.0			3.5		
Walking Speed (m/s)		1.2			1.2			1.2			1.2		
Percent Blockage		15			0			0			1		
Right turn flare (veh)			2										
Median type		None			None								
Median storage veh													
Upstream signal (m)											82		
pX, platoon unblocked	0.93	0.93	0.93	0.93	0.93		0.93						
vC, conflicting volume	1956	2051	534	1048	2051	121	1503			108			
vC1, stage 1 conf vol													
vC2, stage 2 conf vol													
vCu, unblocked vol	1806	1908	282	832	1908	121	1321			108			
tC, single (s)	7.5	6.5	6.9	7.5	6.5	6.9	4.1			4.1			
tC, 2 stage (s)													
tF (s)	3.5	4.0	3.3	3.5	4.0	3.3	2.2			2.2			
p0 queue free %	100	0	72	0	100	100	100			85			
cM capacity (veh/h)	31	46	566	0	46	898	411			1480			
<b>Direction, Lane #</b>	<b>EB 1</b>	<b>SB 1</b>	<b>SB 2</b>	<b>SB 3</b>	<b>SB 4</b>								
Volume Total	304	408	376	376	376								
Volume Left	0	220	0	0	0								
Volume Right	161	0	0	0	0								
cSH	89	1480	1700	1700	1700								
Volume to Capacity	3.42	0.15	0.22	0.22	0.22								
Queue Length 95th (m)	Err	4.0	0.0	0.0	0.0								
Control Delay (s)	Err	4.8	0.0	0.0	0.0								
Lane LOS	F	A											
Approach Delay (s)	Err	1.3											
Approach LOS	F												
<b>Intersection Summary</b>													
Average Delay			1653.8										
Intersection Capacity Utilization			41.6%					ICU Level of Service			A		
Analysis Period (min)			15										



Lane Group	EBL	EBT	EBR	WBL	WBT	WBR	NBL	NBT	NBR	SBL	SBT	SBR
Lane Configurations					↑	↗		↖↖↖				
Ideal Flow (vphpl)	1750	1750	1750	1750	1750	1750	1750	1750	1750	1750	1750	1750
Storage Length (m)	0.0		0.0	0.0		15.0	0.0		0.0	0.0		0.0
Storage Lanes	0		0	0		1	0		0	0		0
Total Lost Time (s)	4.0	4.0	4.0	4.0	4.0	4.0	4.0	4.0	4.0	4.0	4.0	4.0
Turning Speed (k/h)	24		14	24		14	24		14	24		14
Lane Util. Factor	1.00	1.00	1.00	1.00	1.00	1.00	0.91	0.91	1.00	1.00	1.00	1.00
Ped Bike Factor						0.92		0.91				
Frt						0.850						
Flt Protected								0.984				
Satd. Flow (prot)	0	0	0	0	1697	1442	0	4558	0	0	0	0
Flt Permitted								0.984				
Satd. Flow (perm)	0	0	0	0	1697	1325	0	4148	0	0	0	0
Right Turn on Red			Yes			Yes	Yes		Yes			Yes
Satd. Flow (RTOR)						107		133				
Headway Factor	1.01	1.01	1.01	1.01	1.01	1.01	1.01	1.01	1.01	1.01	1.01	1.01
Link Speed (k/h)		50			50			50			50	
Link Distance (m)		182.2			96.8			83.3			76.7	
Travel Time (s)		13.1			7.0			6.0			5.5	
Volume (vph)	0	0	0	0	213	105	202	421	0	0	0	0
Confl. Peds. (#/hr)	46		78	78		46	231		303	303		231
Confl. Bikes (#/hr)						14						2
Peak Hour Factor	0.92	0.92	0.92	0.92	0.92	0.92	0.92	0.92	0.92	0.92	0.92	0.92
Adj. Flow (vph)	0	0	0	0	232	114	220	458	0	0	0	0
Lane Group Flow (vph)	0	0	0	0	232	114	0	678	0	0	0	0
Turn Type						Perm	Perm					
Protected Phases					8			2				
Permitted Phases						8	2					
Minimum Split (s)					19.0	19.0	30.0	30.0				
Total Split (s)	0.0	0.0	0.0	0.0	19.0	19.0	41.0	41.0	0.0	0.0	0.0	0.0
Total Split (%)	0.0%	0.0%	0.0%	0.0%	31.7%	31.7%	68.3%	68.3%	0.0%	0.0%	0.0%	0.0%
Maximum Green (s)					14.0	14.0	36.0	36.0				
Yellow Time (s)					3.3	3.3	3.3	3.3				
All-Red Time (s)					1.7	1.7	1.7	1.7				
Lead/Lag												
Lead-Lag Optimize?												
Walk Time (s)					7.0	7.0	19.0	19.0				
Flash Dont Walk (s)					7.0	7.0	6.0	6.0				
Pedestrian Calls (#/hr)					20	20	40	40				
Act Effct Green (s)					15.0	15.0		37.0				
Actuated g/C Ratio					0.25	0.25		0.62				
v/c Ratio					0.55	0.28		0.26				
Control Delay					25.3	7.1		4.4				
Queue Delay					0.0	0.0		0.0				
Total Delay					25.3	7.1		4.4				
LOS					C	A		A				
Approach Delay					19.3			4.4				
Approach LOS					B			A				

Intersection Summary

Area Type:	Other		
Cycle Length:	60		
Actuated Cycle Length:	60		
Offset:	33 (55%), Referenced to phase 2:NBTL and 6:., Start of Green		
Natural Cycle:	50		
Control Type:	Pretimed		
Maximum v/c Ratio:	0.55		
Intersection Signal Delay:	9.4	Intersection LOS:	A
Intersection Capacity Utilization	39.7%	ICU Level of Service	A
Analysis Period (min)	15		

Splits and Phases: 15: Gloucester & Metcalfe

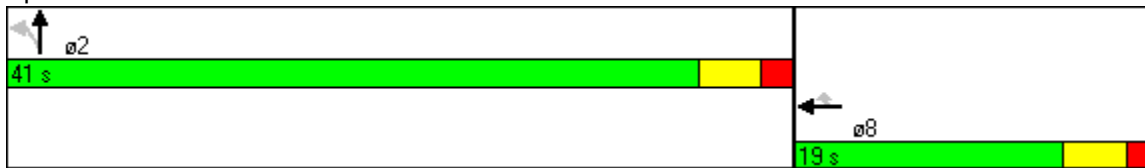





Lane Group	EBL	EBT	EBR	WBL	WBT	WBR	NBL	NBT	NBR	SBL	SBT	SBR
Lane Configurations				↙	↘						↑↑↑	
Ideal Flow (vphpl)	1750	1750	1750	1750	1750	1750	1750	1750	1750	1750	1750	1750
Storage Length (m)	0.0		0.0	15.0		0.0	0.0		0.0	0.0		0.0
Storage Lanes	0		0	1		0	0		0	0		0
Total Lost Time (s)	4.0	4.0	4.0	4.0	4.0	4.0	4.0	4.0	4.0	4.0	4.0	4.0
Turning Speed (k/h)	24		14	24		14	24		14	24		14
Lane Util. Factor	1.00	1.00	1.00	1.00	1.00	1.00	1.00	1.00	1.00	1.00	0.86	0.86
Ped Bike Factor				0.93							0.97	
Frt											0.984	
Flt Protected				0.950								
Satd. Flow (prot)	0	0	0	1612	1697	0	0	0	0	0	5589	0
Flt Permitted				0.950								
Satd. Flow (perm)	0	0	0	1493	1697	0	0	0	0	0	5589	0
Right Turn on Red			Yes	Yes		Yes			Yes			Yes
Satd. Flow (RTOR)				40							77	
Headway Factor	1.01	1.01	1.01	1.01	1.01	1.01	1.01	1.01	1.01	1.01	1.01	1.01
Link Speed (k/h)		50			50			50			50	
Link Distance (m)		108.3			182.2			82.4			78.3	
Travel Time (s)		7.8			13.1			5.9			5.6	
Volume (vph)	0	0	0	300	213	0	0	0	0	0	934	114
Confl. Peds. (#/hr)	197		67	67		197	176		90	90		176
Confl. Bikes (#/hr)			66									17
Peak Hour Factor	0.92	0.92	0.92	0.92	0.92	0.92	0.92	0.92	0.92	0.92	0.92	0.92
Adj. Flow (vph)	0	0	0	326	232	0	0	0	0	0	1015	124
Lane Group Flow (vph)	0	0	0	326	232	0	0	0	0	0	1139	0
Turn Type				Perm								
Protected Phases					8						6	
Permitted Phases				8								
Minimum Split (s)				20.3	20.3						27.1	
Total Split (s)	0.0	0.0	0.0	24.0	24.0	0.0	0.0	0.0	0.0	0.0	31.0	0.0
Total Split (%)	0.0%	0.0%	0.0%	43.6%	43.6%	0.0%	0.0%	0.0%	0.0%	0.0%	56.4%	0.0%
Maximum Green (s)				18.7	18.7						25.9	
Yellow Time (s)				3.3	3.3						3.3	
All-Red Time (s)				2.0	2.0						1.8	
Lead/Lag												
Lead-Lag Optimize?												
Walk Time (s)				7.0	7.0						15.0	
Flash Dont Walk (s)				8.0	8.0						7.0	
Pedestrian Calls (#/hr)				20	20						40	
Act Effct Green (s)				20.0	20.0						27.0	
Actuated g/C Ratio				0.36	0.36						0.49	
v/c Ratio				0.57	0.38						0.41	
Control Delay				17.1	15.2						8.8	
Queue Delay				0.0	0.0						0.0	
Total Delay				17.1	15.2						8.8	
LOS				B	B						A	
Approach Delay					16.3						8.8	
Approach LOS					B						A	

Intersection Summary

Area Type:	Other		
Cycle Length:	55		
Actuated Cycle Length:	55		
Offset:	13 (24%), Referenced to phase 2: and 6:SBT, Start of Green		
Natural Cycle:	50		
Control Type:	Pretimed		
Maximum v/c Ratio:	0.57		
Intersection Signal Delay:	11.3	Intersection LOS:	B
Intersection Capacity Utilization	43.0%	ICU Level of Service	A
Analysis Period (min)	15		

Splits and Phases: 16: Gloucester & O'Connor





Lane Group	EBL	EBT	EBR	WBL	WBT	WBR	NBL	NBT	NBR	SBL	SBT	SBR
Lane Configurations												
Ideal Flow (vphpl)	1750	1750	1750	1750	1750	1750	1750	1750	1750	1750	1750	1750
Storage Length (m)	15.0		0.0	0.0		0.0	0.0		0.0	0.0		0.0
Storage Lanes	1		0	0		0	0		0	0		0
Total Lost Time (s)	4.0	4.0	4.0	4.0	4.0	4.0	4.0	4.0	4.0	4.0	4.0	4.0
Turning Speed (k/h)	24		14	24		14	24		14	24		14
Lane Util. Factor	1.00	1.00	1.00	1.00	1.00	1.00	1.00	0.91	0.91	1.00	1.00	1.00
Ped Bike Factor	0.95							0.94				
Frt								0.968				
Flt Protected	0.950											
Satd. Flow (prot)	1612	1697	0	0	0	0	0	4204	0	0	0	0
Flt Permitted	0.950											
Satd. Flow (perm)	1529	1697	0	0	0	0	0	4204	0	0	0	0
Right Turn on Red	Yes		Yes			Yes			Yes			Yes
Satd. Flow (RTOR)	13							173				
Headway Factor	1.01	1.01	1.01	1.01	1.01	1.01	1.01	1.01	1.01	1.01	1.01	1.01
Link Speed (k/h)		50			50			50				50
Link Distance (m)		182.6			94.2			73.5				83.3
Travel Time (s)		13.1			6.8			5.3				6.0
Volume (vph)	145	130	0	0	0	0	0	959	258	0	0	0
Confl. Peds. (#/hr)	40		40	40		40	330		225	225		330
Confl. Bikes (#/hr)						78			19			
Peak Hour Factor	0.92	0.92	0.92	0.92	0.92	0.92	0.92	0.92	0.92	0.92	0.92	0.92
Adj. Flow (vph)	158	141	0	0	0	0	0	1042	280	0	0	0
Lane Group Flow (vph)	158	141	0	0	0	0	0	1322	0	0	0	0
Turn Type	Perm											
Protected Phases		4						2				
Permitted Phases	4											
Minimum Split (s)	23.0	23.0						35.0				
Total Split (s)	24.0	24.0	0.0	0.0	0.0	0.0	0.0	36.0	0.0	0.0	0.0	0.0
Total Split (%)	40.0%	40.0%	0.0%	0.0%	0.0%	0.0%	0.0%	60.0%	0.0%	0.0%	0.0%	0.0%
Maximum Green (s)	19.0	19.0						31.0				
Yellow Time (s)	3.3	3.3						3.3				
All-Red Time (s)	1.7	1.7						1.7				
Lead/Lag	Lead-Lag Optimize?											
Walk Time (s)	7.0	7.0						19.0				
Flash Dont Walk (s)	7.0	7.0						6.0				
Pedestrian Calls (#/hr)	0	0						0				
Act Effct Green (s)	20.0	20.0						32.0				
Actuated g/C Ratio	0.33	0.33						0.53				
v/c Ratio	0.31	0.25						0.57				
Control Delay	19.2	19.7						9.2				
Queue Delay	0.0	0.0						0.0				
Total Delay	19.2	19.7						9.2				
LOS	B	B						A				
Approach Delay		19.4						9.2				
Approach LOS		B						A				

Intersection Summary

Area Type:	Other		
Cycle Length:	60		
Actuated Cycle Length:	60		
Offset:	26 (43%), Referenced to phase 2:NBT and 6:, Start of Green		
Natural Cycle:	60		
Control Type:	Pretimed		
Maximum v/c Ratio:	0.57		
Intersection Signal Delay:	11.0	Intersection LOS:	B
Intersection Capacity Utilization	73.9%	ICU Level of Service	D
Analysis Period (min)	15		

Splits and Phases: 1: Nepean & Metcalfe

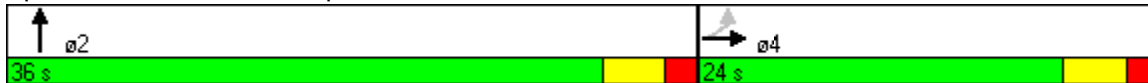



Lane Group	EBL	EBT	EBR	WBL	WBT	WBR	NBL	NBT	NBR	SBL	SBT	SBR
Lane Configurations		↑	↗								↑↑↑	
Ideal Flow (vphpl)	1750	1750	1750	1750	1750	1750	1750	1750	1750	1750	1750	1750
Storage Length (m)	0.0		15.0	0.0		0.0	0.0		0.0	0.0		0.0
Storage Lanes	0		1	0		0	0		0	0		0
Total Lost Time (s)	4.0	4.0	4.0	4.0	4.0	4.0	4.0	4.0	4.0	4.0	4.0	4.0
Turning Speed (k/h)	24		14	24		14	24		14	24		14
Lane Util. Factor	1.00	1.00	1.00	1.00	1.00	1.00	1.00	1.00	1.00	0.86	0.86	1.00
Ped Bike Factor			0.95								0.95	
Frt			0.850									
Flt Protected											0.990	
Satd. Flow (prot)	0	1697	1442	0	0	0	0	0	0	0	5778	0
Flt Permitted											0.990	
Satd. Flow (perm)	0	1697	1372	0	0	0	0	0	0	0	5503	0
Right Turn on Red			Yes			Yes			Yes	Yes		Yes
Satd. Flow (RTOR)			34								152	
Headway Factor	1.01	1.01	1.01	1.01	1.01	1.01	1.01	1.01	1.01	1.01	1.01	1.01
Link Speed (k/h)		50			50			50			50	
Link Distance (m)		109.5			182.6			73.8			82.4	
Travel Time (s)		7.9			13.1			5.3			5.9	
Volume (vph)	0	115	74	0	0	0	0	0	0	184	728	0
Confl. Peds. (#/hr)	32		25	25		32	237		173	173		237
Confl. Bikes (#/hr)			12			1			13			
Peak Hour Factor	0.92	0.92	0.92	0.92	0.92	0.92	0.92	0.92	0.92	0.92	0.92	0.92
Adj. Flow (vph)	0	125	80	0	0	0	0	0	0	200	791	0
Lane Group Flow (vph)	0	125	80	0	0	0	0	0	0	0	991	0
Turn Type			Perm								Perm	
Protected Phases		4										6
Permitted Phases			4								6	
Minimum Split (s)		23.3	23.3							31.1	31.1	
Total Split (s)	0.0	26.0	26.0	0.0	0.0	0.0	0.0	0.0	0.0	34.0	34.0	0.0
Total Split (%)	0.0%	43.3%	43.3%	0.0%	0.0%	0.0%	0.0%	0.0%	0.0%	56.7%	56.7%	0.0%
Maximum Green (s)		20.7	20.7							28.9	28.9	
Yellow Time (s)		3.3	3.3							3.3	3.3	
All-Red Time (s)		2.0	2.0							1.8	1.8	
Lead/Lag												
Lead-Lag Optimize?												
Walk Time (s)		7.0	7.0							15.0	15.0	
Flash Dont Walk (s)		8.0	8.0							7.0	7.0	
Pedestrian Calls (#/hr)		0	0							0	0	
Act Effct Green (s)		22.0	22.0								30.0	
Actuated g/C Ratio		0.37	0.37								0.50	
v/c Ratio		0.20	0.15								0.35	
Control Delay		14.1	9.3								5.5	
Queue Delay		0.0	0.0								0.0	
Total Delay		14.1	9.3								5.5	
LOS		B	A								A	
Approach Delay		12.2									5.5	
Approach LOS		B									A	

Intersection Summary

Area Type:	Other
Cycle Length:	60
Actuated Cycle Length:	60
Offset:	7 (12%), Referenced to phase 2: and 6:SBTL, Start of Green
Natural Cycle:	55
Control Type:	Pretimed
Maximum v/c Ratio:	0.35
Intersection Signal Delay:	6.6
Intersection LOS:	A
Intersection Capacity Utilization	46.4%
ICU Level of Service	A
Analysis Period (min)	15

Splits and Phases: 13: Nepean & O'Connor





Lane Group	EBL	EBT	EBR	WBL	WBT	WBR	NBL	NBT	NBR	SBL	SBT	SBR
Lane Configurations					↑	↗		↖↖↖				
Ideal Flow (vphpl)	1750	1750	1750	1750	1750	1750	1750	1750	1750	1750	1750	1750
Storage Length (m)	0.0		0.0	0.0		15.0	0.0		0.0	0.0		0.0
Storage Lanes	0		0	0		1	0		0	0		0
Total Lost Time (s)	4.0	4.0	4.0	4.0	4.0	4.0	4.0	4.0	4.0	4.0	4.0	4.0
Turning Speed (k/h)	24		14	24		14	24		14	24		14
Lane Util. Factor	1.00	1.00	1.00	1.00	1.00	1.00	0.91	0.91	1.00	1.00	1.00	1.00
Ped Bike Factor						0.87		0.95				
Frt						0.850						
Flt Protected								0.983				
Satd. Flow (prot)	0	0	0	0	1697	1442	0	4553	0	0	0	0
Flt Permitted								0.983				
Satd. Flow (perm)	0	0	0	0	1697	1259	0	4340	0	0	0	0
Right Turn on Red			Yes			Yes	Yes		Yes			Yes
Satd. Flow (RTOR)						68		244				
Headway Factor	1.01	1.01	1.01	1.01	1.01	1.01	1.01	1.01	1.01	1.01	1.01	1.01
Link Speed (k/h)		50			50			50			50	
Link Distance (m)		182.2			96.8			83.3			76.7	
Travel Time (s)		13.1			7.0			6.0			5.5	
Volume (vph)	0	0	0	0	148	63	285	534	0	0	0	0
Confl. Peds. (#/hr)	54		59	59		54	112		267	267		112
Confl. Bikes (#/hr)						60						9
Peak Hour Factor	0.92	0.92	0.92	0.92	0.92	0.92	0.92	0.92	0.92	0.92	0.92	0.92
Adj. Flow (vph)	0	0	0	0	161	68	310	580	0	0	0	0
Lane Group Flow (vph)	0	0	0	0	161	68	0	890	0	0	0	0
Turn Type						Perm	Perm					
Protected Phases					8			2				
Permitted Phases						8	2					
Minimum Split (s)					19.0	19.0	30.0	30.0				
Total Split (s)	0.0	0.0	0.0	0.0	19.0	19.0	41.0	41.0	0.0	0.0	0.0	0.0
Total Split (%)	0.0%	0.0%	0.0%	0.0%	31.7%	31.7%	68.3%	68.3%	0.0%	0.0%	0.0%	0.0%
Maximum Green (s)					14.0	14.0	36.0	36.0				
Yellow Time (s)					3.3	3.3	3.3	3.3				
All-Red Time (s)					1.7	1.7	1.7	1.7				
Lead/Lag												
Lead-Lag Optimize?												
Walk Time (s)					7.0	7.0	19.0	19.0				
Flash Dont Walk (s)					7.0	7.0	6.0	6.0				
Pedestrian Calls (#/hr)					20	20	40	40				
Act Effct Green (s)					15.0	15.0		37.0				
Actuated g/C Ratio					0.25	0.25		0.62				
v/c Ratio					0.38	0.19		0.32				
Control Delay					21.8	7.0		1.2				
Queue Delay					0.0	0.0		0.1				
Total Delay					21.8	7.0		1.3				
LOS					C	A		A				
Approach Delay					17.4			1.3				
Approach LOS					B			A				

Intersection Summary

Area Type:	Other		
Cycle Length:	60		
Actuated Cycle Length:	60		
Offset:	33 (55%), Referenced to phase 2:NBTL and 6:., Start of Green		
Natural Cycle:	50		
Control Type:	Pretimed		
Maximum v/c Ratio:	0.38		
Intersection Signal Delay:	4.6	Intersection LOS:	A
Intersection Capacity Utilization	39.2%	ICU Level of Service	A
Analysis Period (min)	15		

Splits and Phases: 15: Gloucester & Metcalfe

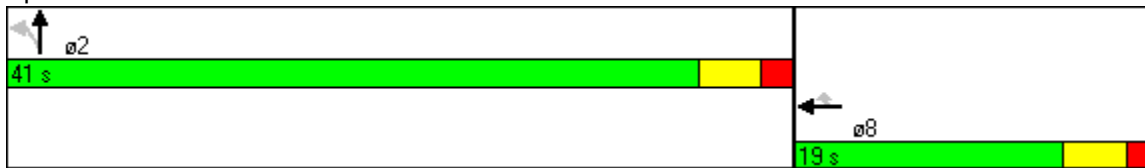





Lane Group	EBL	EBT	EBR	WBL	WBT	WBR	NBL	NBT	NBR	SBL	SBT	SBR
Lane Configurations				↙	↘						↑↑↑	
Ideal Flow (vphpl)	1750	1750	1750	1750	1750	1750	1750	1750	1750	1750	1750	1750
Storage Length (m)	0.0		0.0	15.0		0.0	0.0		0.0	0.0		0.0
Storage Lanes	0		0	1		0	0		0	0		0
Total Lost Time (s)	4.0	4.0	4.0	4.0	4.0	4.0	4.0	4.0	4.0	4.0	4.0	4.0
Turning Speed (k/h)	24		14	24		14	24		14	24		14
Lane Util. Factor	1.00	1.00	1.00	1.00	1.00	1.00	1.00	1.00	1.00	1.00	0.86	0.86
Ped Bike Factor				0.96							0.95	
Frt											0.962	
Flt Protected				0.950								
Satd. Flow (prot)	0	0	0	1612	1697	0	0	0	0	0	5359	0
Flt Permitted				0.950								
Satd. Flow (perm)	0	0	0	1540	1697	0	0	0	0	0	5359	0
Right Turn on Red			Yes	Yes		Yes			Yes			Yes
Satd. Flow (RTOR)				122							100	
Headway Factor	1.01	1.01	1.01	1.01	1.01	1.01	1.01	1.01	1.01	1.01	1.01	1.01
Link Speed (k/h)		50			50			50			50	
Link Distance (m)		108.3			182.2			82.4			78.3	
Travel Time (s)		7.8			13.1			5.9			5.6	
Volume (vph)	0	0	0	209	191	0	0	0	0	0	526	180
Confl. Peds. (#/hr)	198		37	37		198	105		138	138		105
Confl. Bikes (#/hr)			34			1						29
Peak Hour Factor	0.92	0.92	0.92	0.92	0.92	0.92	0.92	0.92	0.92	0.92	0.92	0.92
Adj. Flow (vph)	0	0	0	227	208	0	0	0	0	0	572	196
Lane Group Flow (vph)	0	0	0	227	208	0	0	0	0	0	768	0
Turn Type				Perm								
Protected Phases					8						6	
Permitted Phases				8								
Minimum Split (s)				25.0	25.0						35.0	
Total Split (s)	0.0	0.0	0.0	25.0	25.0	0.0	0.0	0.0	0.0	0.0	35.0	0.0
Total Split (%)	0.0%	0.0%	0.0%	41.7%	41.7%	0.0%	0.0%	0.0%	0.0%	0.0%	58.3%	0.0%
Maximum Green (s)				19.7	19.7						29.9	
Yellow Time (s)				3.3	3.3						3.3	
All-Red Time (s)				2.0	2.0						1.8	
Lead/Lag												
Lead-Lag Optimize?												
Walk Time (s)				7.0	7.0						15.0	
Flash Dont Walk (s)				8.0	8.0						7.0	
Pedestrian Calls (#/hr)				20	20						40	
Act Effct Green (s)				21.0	21.0						31.0	
Actuated g/C Ratio				0.35	0.35						0.52	
v/c Ratio				0.37	0.35						0.27	
Control Delay				5.9	12.4						7.3	
Queue Delay				0.0	0.0						0.0	
Total Delay				5.9	12.4						7.3	
LOS				A	B						A	
Approach Delay					9.0						7.3	
Approach LOS					A						A	

Intersection Summary

Area Type:	Other
Cycle Length:	60
Actuated Cycle Length:	60
Offset:	1 (2%), Referenced to phase 2: and 6:SBT, Start of Green
Natural Cycle:	60
Control Type:	Pretimed
Maximum v/c Ratio:	0.37
Intersection Signal Delay:	7.9
Intersection LOS:	A
Intersection Capacity Utilization	39.2%
ICU Level of Service	A
Analysis Period (min)	15

Splits and Phases: 16: Gloucester & O'Connor





Lane Group	EBL	EBT	EBR	WBL	WBT	WBR	NBL	NBT	NBR	SBL	SBT	SBR
Lane Configurations												
Ideal Flow (vphpl)	1750	1750	1750	1750	1750	1750	1750	1750	1750	1750	1750	1750
Storage Length (m)	15.0		0.0	0.0		0.0	0.0		0.0	0.0		0.0
Storage Lanes	1		0	0		0	0		0	0		0
Total Lost Time (s)	4.0	4.0	4.0	4.0	4.0	4.0	4.0	4.0	4.0	4.0	4.0	4.0
Turning Speed (k/h)	24		14	24		14	24		14	24		14
Lane Util. Factor	1.00	1.00	1.00	1.00	1.00	1.00	1.00	0.91	0.91	1.00	1.00	1.00
Ped Bike Factor	0.95							0.93				
Frt								0.952				
Flt Protected	0.950											
Satd. Flow (prot)	1612	1697	0	0	0	0	0	4122	0	0	0	0
Flt Permitted	0.950											
Satd. Flow (perm)	1529	1697	0	0	0	0	0	4122	0	0	0	0
Right Turn on Red	Yes		Yes			Yes			Yes			Yes
Satd. Flow (RTOR)	82							263				
Headway Factor	1.01	1.01	1.01	1.01	1.01	1.01	1.01	1.01	1.01	1.01	1.01	1.01
Link Speed (k/h)		50			50			50				50
Link Distance (m)		182.6			94.2			73.5				83.3
Travel Time (s)		13.1			6.8			5.3				6.0
Volume (vph)	173	155	0	0	0	0	0	514	242	0	0	0
Confl. Peds. (#/hr)	40		40	40		40	232		146	146		232
Confl. Bikes (#/hr)						19			21			
Peak Hour Factor	0.92	0.92	0.92	0.92	0.92	0.92	0.92	0.92	0.92	0.92	0.92	0.92
Adj. Flow (vph)	188	168	0	0	0	0	0	559	263	0	0	0
Lane Group Flow (vph)	188	168	0	0	0	0	0	822	0	0	0	0
Turn Type	Perm											
Protected Phases		4						2				
Permitted Phases	4											
Minimum Split (s)	23.0	23.0						35.0				
Total Split (s)	24.0	24.0	0.0	0.0	0.0	0.0	0.0	36.0	0.0	0.0	0.0	0.0
Total Split (%)	40.0%	40.0%	0.0%	0.0%	0.0%	0.0%	0.0%	60.0%	0.0%	0.0%	0.0%	0.0%
Maximum Green (s)	19.0	19.0						31.0				
Yellow Time (s)	3.3	3.3						3.3				
All-Red Time (s)	1.7	1.7						1.7				
Lead/Lag												
Lead-Lag Optimize?												
Walk Time (s)	7.0	7.0						19.0				
Flash Dont Walk (s)	7.0	7.0						6.0				
Pedestrian Calls (#/hr)	0	0						0				
Act Effct Green (s)	20.0	20.0						32.0				
Actuated g/C Ratio	0.33	0.33						0.53				
v/c Ratio	0.33	0.30						0.35				
Control Delay	10.6	16.6						5.7				
Queue Delay	0.0	0.0						0.0				
Total Delay	10.6	16.6						5.7				
LOS	B	B						A				
Approach Delay		13.5						5.7				
Approach LOS		B						A				

Intersection Summary

Area Type:	Other		
Cycle Length:	60		
Actuated Cycle Length:	60		
Offset:	29 (48%), Referenced to phase 2:NBT and 6:, Start of Green		
Natural Cycle:	60		
Control Type:	Pretimed		
Maximum v/c Ratio:	0.35		
Intersection Signal Delay:	8.1	Intersection LOS:	A
Intersection Capacity Utilization	70.7%	ICU Level of Service	C
Analysis Period (min)	15		

Splits and Phases: 1: Nepean & Metcalfe

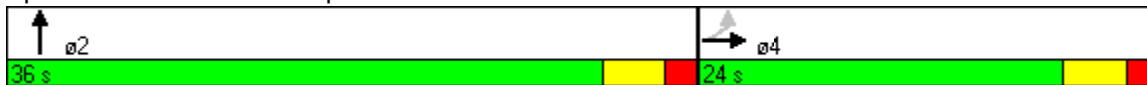



Lane Group	EBL	EBT	EBR	WBL	WBT	WBR	NBL	NBT	NBR	SBL	SBT	SBR
Lane Configurations		↑	↗								↑↑↑	
Ideal Flow (vphpl)	1750	1750	1750	1750	1750	1750	1750	1750	1750	1750	1750	1750
Storage Length (m)	0.0		15.0	0.0		0.0	0.0		0.0	0.0		0.0
Storage Lanes	0		1	0		0	0		0	0		0
Total Lost Time (s)	4.0	4.0	4.0	4.0	4.0	4.0	4.0	4.0	4.0	4.0	4.0	4.0
Turning Speed (k/h)	24		14	24		14	24		14	24		14
Lane Util. Factor	1.00	1.00	1.00	1.00	1.00	1.00	1.00	1.00	1.00	0.86	0.86	1.00
Ped Bike Factor			0.94								0.98	
Frt			0.850									
Flt Protected											0.993	
Satd. Flow (prot)	0	1697	1442	0	0	0	0	0	0	0	5796	0
Flt Permitted											0.993	
Satd. Flow (perm)	0	1697	1360	0	0	0	0	0	0	0	5684	0
Right Turn on Red			Yes			Yes			Yes	Yes		Yes
Satd. Flow (RTOR)			9								108	
Headway Factor	1.01	1.01	1.01	1.01	1.01	1.01	1.01	1.01	1.01	1.01	1.01	1.01
Link Speed (k/h)		50			50			50			50	
Link Distance (m)		109.5			182.6			73.8			82.4	
Travel Time (s)		7.9			13.1			5.3			5.9	
Volume (vph)	0	132	148	0	0	0	0	0	0	202	1212	0
Confl. Peds. (#/hr)	13		19	19		13	186		108	108		186
Confl. Bikes (#/hr)			41			1			25			
Peak Hour Factor	0.92	0.92	0.92	0.92	0.92	0.92	0.92	0.92	0.92	0.92	0.92	0.92
Adj. Flow (vph)	0	143	161	0	0	0	0	0	0	220	1317	0
Lane Group Flow (vph)	0	143	161	0	0	0	0	0	0	0	1537	0
Turn Type			Perm							Perm		
Protected Phases		4									6	
Permitted Phases			4							6		
Minimum Split (s)		20.3	20.3							27.1	27.1	
Total Split (s)	0.0	24.0	24.0	0.0	0.0	0.0	0.0	0.0	0.0	31.0	31.0	0.0
Total Split (%)	0.0%	43.6%	43.6%	0.0%	0.0%	0.0%	0.0%	0.0%	0.0%	56.4%	56.4%	0.0%
Maximum Green (s)		18.7	18.7							25.9	25.9	
Yellow Time (s)		3.3	3.3							3.3	3.3	
All-Red Time (s)		2.0	2.0							1.8	1.8	
Lead/Lag												
Lead-Lag Optimize?												
Walk Time (s)		7.0	7.0							15.0	15.0	
Flash Dont Walk (s)		8.0	8.0							7.0	7.0	
Pedestrian Calls (#/hr)		0	0							0	0	
Act Effct Green (s)		20.0	20.0							27.0	27.0	
Actuated g/C Ratio		0.36	0.36							0.49	0.49	
v/c Ratio		0.23	0.32							0.54	0.54	
Control Delay		13.5	14.1							6.2	6.2	
Queue Delay		0.0	0.0							0.1	0.1	
Total Delay		13.5	14.1							6.3	6.3	
LOS		B	B							A	A	
Approach Delay		13.8								6.3	6.3	
Approach LOS		B								A	A	

Intersection Summary

Area Type:	Other
Cycle Length:	55
Actuated Cycle Length:	55
Offset:	15 (27%), Referenced to phase 2: and 6:SBTL, Start of Green
Natural Cycle:	50
Control Type:	Pretimed
Maximum v/c Ratio:	0.54
Intersection Signal Delay:	7.5
Intersection LOS:	A
Intersection Capacity Utilization	41.6%
ICU Level of Service	A
Analysis Period (min)	15

Splits and Phases: 13: Nepean & O'Connor





Lane Group	EBL	EBT	EBR	WBL	WBT	WBR	NBL	NBT	NBR	SBL	SBT	SBR
Lane Configurations					↑	↗		↖↖↖				
Ideal Flow (vphpl)	1750	1750	1750	1750	1750	1750	1750	1750	1750	1750	1750	1750
Storage Length (m)	0.0		0.0	0.0		15.0	0.0		0.0	0.0		0.0
Storage Lanes	0		0	0		1	0		0	0		0
Total Lost Time (s)	4.0	4.0	4.0	4.0	4.0	4.0	4.0	4.0	4.0	4.0	4.0	4.0
Turning Speed (k/h)	24		14	24		14	24		14	24		14
Lane Util. Factor	1.00	1.00	1.00	1.00	1.00	1.00	0.91	0.91	1.00	1.00	1.00	1.00
Ped Bike Factor						0.92		0.91				
Frt						0.850						
Flt Protected								0.984				
Satd. Flow (prot)	0	0	0	0	1697	1442	0	4558	0	0	0	0
Flt Permitted								0.984				
Satd. Flow (perm)	0	0	0	0	1697	1325	0	4148	0	0	0	0
Right Turn on Red			Yes			Yes	Yes		Yes			Yes
Satd. Flow (RTOR)						107		133				
Headway Factor	1.01	1.01	1.01	1.01	1.01	1.01	1.01	1.01	1.01	1.01	1.01	1.01
Link Speed (k/h)		50			50			50			50	
Link Distance (m)		182.2			96.8			83.3			76.7	
Travel Time (s)		13.1			7.0			6.0			5.5	
Volume (vph)	0	0	0	0	213	105	202	421	0	0	0	0
Confl. Peds. (#/hr)	46		78	78		46	231		303	303		231
Confl. Bikes (#/hr)						14						2
Peak Hour Factor	0.92	0.92	0.92	0.92	0.92	0.92	0.92	0.92	0.92	0.92	0.92	0.92
Adj. Flow (vph)	0	0	0	0	232	114	220	458	0	0	0	0
Lane Group Flow (vph)	0	0	0	0	232	114	0	678	0	0	0	0
Turn Type						Perm	Perm					
Protected Phases					8			2				
Permitted Phases						8	2					
Minimum Split (s)					19.0	19.0	30.0	30.0				
Total Split (s)	0.0	0.0	0.0	0.0	19.0	19.0	41.0	41.0	0.0	0.0	0.0	0.0
Total Split (%)	0.0%	0.0%	0.0%	0.0%	31.7%	31.7%	68.3%	68.3%	0.0%	0.0%	0.0%	0.0%
Maximum Green (s)					14.0	14.0	36.0	36.0				
Yellow Time (s)					3.3	3.3	3.3	3.3				
All-Red Time (s)					1.7	1.7	1.7	1.7				
Lead/Lag												
Lead-Lag Optimize?												
Walk Time (s)					7.0	7.0	19.0	19.0				
Flash Dont Walk (s)					7.0	7.0	6.0	6.0				
Pedestrian Calls (#/hr)					20	20	40	40				
Act Effct Green (s)					15.0	15.0		37.0				
Actuated g/C Ratio					0.25	0.25		0.62				
v/c Ratio					0.55	0.28		0.26				
Control Delay					25.3	7.1		3.4				
Queue Delay					0.0	0.0		0.0				
Total Delay					25.3	7.1		3.4				
LOS					C	A		A				
Approach Delay					19.3			3.4				
Approach LOS					B			A				

Intersection Summary

Area Type:	Other		
Cycle Length:	60		
Actuated Cycle Length:	60		
Offset:	35 (58%), Referenced to phase 2:NBTL and 6:., Start of Green		
Natural Cycle:	50		
Control Type:	Pretimed		
Maximum v/c Ratio:	0.55		
Intersection Signal Delay:	8.7	Intersection LOS:	A
Intersection Capacity Utilization	39.7%	ICU Level of Service	A
Analysis Period (min)	15		

Splits and Phases: 15: Gloucester & Metcalfe

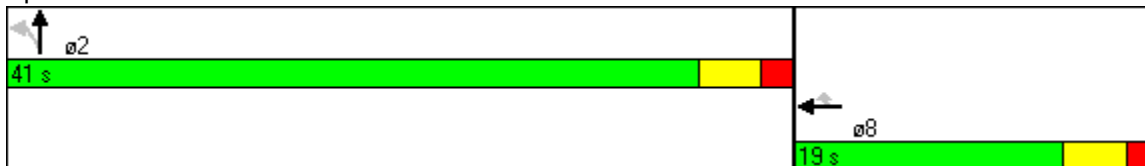



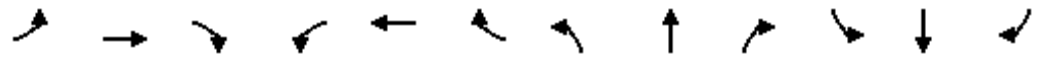

Lane Group	EBL	EBT	EBR	WBL	WBT	WBR	NBL	NBT	NBR	SBL	SBT	SBR
Lane Configurations				↙	↘						↑↑↑	
Ideal Flow (vphpl)	1750	1750	1750	1750	1750	1750	1750	1750	1750	1750	1750	1750
Storage Length (m)	0.0		0.0	15.0		0.0	0.0		0.0	0.0		0.0
Storage Lanes	0		0	1		0	0		0	0		0
Total Lost Time (s)	4.0	4.0	4.0	4.0	4.0	4.0	4.0	4.0	4.0	4.0	4.0	4.0
Turning Speed (k/h)	24		14	24		14	24		14	24		14
Lane Util. Factor	1.00	1.00	1.00	1.00	1.00	1.00	1.00	1.00	1.00	1.00	0.86	0.86
Ped Bike Factor				0.93							0.97	
Frt											0.984	
Flt Protected				0.950								
Satd. Flow (prot)	0	0	0	1612	1697	0	0	0	0	0	5589	0
Flt Permitted				0.950								
Satd. Flow (perm)	0	0	0	1493	1697	0	0	0	0	0	5589	0
Right Turn on Red			Yes	Yes		Yes			Yes			Yes
Satd. Flow (RTOR)				40							77	
Headway Factor	1.01	1.01	1.01	1.01	1.01	1.01	1.01	1.01	1.01	1.01	1.01	1.01
Link Speed (k/h)		50			50			50			50	
Link Distance (m)		108.3			182.2			82.4			78.3	
Travel Time (s)		7.8			13.1			5.9			5.6	
Volume (vph)	0	0	0	300	213	0	0	0	0	0	934	114
Confl. Peds. (#/hr)	197		67	67		197	176		90	90		176
Confl. Bikes (#/hr)			66									17
Peak Hour Factor	0.92	0.92	0.92	0.92	0.92	0.92	0.92	0.92	0.92	0.92	0.92	0.92
Adj. Flow (vph)	0	0	0	326	232	0	0	0	0	0	1015	124
Lane Group Flow (vph)	0	0	0	326	232	0	0	0	0	0	1139	0
Turn Type				Perm								
Protected Phases					8						6	
Permitted Phases				8								
Minimum Split (s)				20.3	20.3						27.1	
Total Split (s)	0.0	0.0	0.0	24.0	24.0	0.0	0.0	0.0	0.0	0.0	31.0	0.0
Total Split (%)	0.0%	0.0%	0.0%	43.6%	43.6%	0.0%	0.0%	0.0%	0.0%	0.0%	56.4%	0.0%
Maximum Green (s)				18.7	18.7						25.9	
Yellow Time (s)				3.3	3.3						3.3	
All-Red Time (s)				2.0	2.0						1.8	
Lead/Lag												
Lead-Lag Optimize?												
Walk Time (s)				7.0	7.0						15.0	
Flash Dont Walk (s)				8.0	8.0						7.0	
Pedestrian Calls (#/hr)				20	20						40	
Act Effct Green (s)				20.0	20.0						27.0	
Actuated g/C Ratio				0.36	0.36						0.49	
v/c Ratio				0.57	0.38						0.41	
Control Delay				17.1	15.2						8.8	
Queue Delay				0.0	0.0						0.0	
Total Delay				17.1	15.2						8.8	
LOS				B	B						A	
Approach Delay					16.3						8.8	
Approach LOS					B						A	

Intersection Summary

Area Type:	Other		
Cycle Length:	55		
Actuated Cycle Length:	55		
Offset:	13 (24%), Referenced to phase 2: and 6:SBT, Start of Green		
Natural Cycle:	50		
Control Type:	Pretimed		
Maximum v/c Ratio:	0.57		
Intersection Signal Delay:	11.3	Intersection LOS:	B
Intersection Capacity Utilization	43.0%	ICU Level of Service	A
Analysis Period (min)	15		

Splits and Phases: 16: Gloucester & O'Connor



## **APPENDIX D2**

---

### **Intersection Analysis Reports (Total Traffic)**



Movement	EBL	EBT	EBR	WBL	WBT	WBR	NBL	NBT	NBR	SBL	SBT	SBR
Lane Configurations	↘	↑						↑↑↑				
Sign Control	Stop		Stop		Stop		Free		Free		Free	
Grade	0%		0%		0%		0%		0%		0%	
Volume (veh/h)	182	132	0	0	0	0	0	917	248	0	0	0
Peak Hour Factor	0.92	0.92	0.92	0.92	0.92	0.92	0.92	0.92	0.92	0.92	0.92	0.92
Hourly flow rate (vph)	198	143	0	0	0	0	0	997	270	0	0	0
Pedestrians	330		225		40		40		40		40	
Lane Width (m)	3.5		0.0		3.5		0.0		3.5		0.0	
Walking Speed (m/s)	1.2		1.2		1.2		1.2		1.2		1.2	
Percent Blockage	27		0		3		0		3		0	
Right turn flare (veh)												
Median type	None		None									
Median storage veh												
Upstream signal (m)											83	
pX, platoon unblocked												
vC, conflicting volume	702	1821	370	1468	1687	732	330			1491		
vC1, stage 1 conf vol												
vC2, stage 2 conf vol												
vCu, unblocked vol	702	1821	370	1468	1687	732	330			1491		
tC, single (s)	7.5	6.5	6.9	7.5	6.5	6.9	4.1			4.1		
tC, 2 stage (s)												
tF (s)	3.5	4.0	3.3	3.5	4.0	3.3	2.2			2.2		
p0 queue free %	0	0	100	0	100	100	100			100		
cM capacity (veh/h)	189	56	445	0	68	364	898			446		
<b>Direction, Lane #</b>	<b>EB 1</b>	<b>EB 2</b>	<b>NB 1</b>	<b>NB 2</b>	<b>NB 3</b>							
Volume Total	198	143	399	399	469							
Volume Left	198	0	0	0	0							
Volume Right	0	0	0	0	270							
cSH	189	56	1700	1700	1700							
Volume to Capacity	1.05	2.56	0.23	0.23	0.28							
Queue Length 95th (m)	69.9	111.0	0.0	0.0	0.0							
Control Delay (s)	130.2	862.3	0.0	0.0	0.0							
Lane LOS	F	F										
Approach Delay (s)	438.0		0.0									
Approach LOS	F											
<b>Intersection Summary</b>												
Average Delay			93.0									
Intersection Capacity Utilization			45.4%	ICU Level of Service	A							
Analysis Period (min)			15									



Movement	EBL	EBT	EBR	WBL	WBT	WBR	NBL	NBT	NBR	SBL	SBT	SBR
Lane Configurations		↑	↗								↑↑↑	
Sign Control		Stop			Stop			Free			Free	
Grade		0%			0%			0%			0%	
Volume (veh/h)	0	111	70	0	0	0	0	0	0	187	711	0
Peak Hour Factor	0.92	0.92	0.92	0.92	0.92	0.92	0.92	0.92	0.92	0.92	0.92	0.92
Hourly flow rate (vph)	0	121	76	0	0	0	0	0	0	203	773	0
Pedestrians		237			173			25			32	
Lane Width (m)		3.5			0.0			0.0			3.5	
Walking Speed (m/s)		1.2			1.2			1.2			1.2	
Percent Blockage		19			0			0			3	
Right turn flare (veh)			2									
Median type		None			None							
Median storage veh												
Upstream signal (m)											82	
pX, platoon unblocked												
vC, conflicting volume	1448	1589	455	896	1589	205	1010			173		
vC1, stage 1 conf vol												
vC2, stage 2 conf vol												
vCu, unblocked vol	1448	1589	455	896	1589	205	1010			173		
tC, single (s)	7.5	6.5	6.9	7.5	6.5	6.9	4.1			4.1		
tC, 2 stage (s)												
tF (s)	3.5	4.0	3.3	3.5	4.0	3.3	2.2			2.2		
p0 queue free %	100	0	83	0	100	100	100			85		
cM capacity (veh/h)	55	74	446	0	74	781	551			1401		
<b>Direction, Lane #</b>	<b>EB 1</b>	<b>SB 1</b>	<b>SB 2</b>	<b>SB 3</b>	<b>SB 4</b>							
Volume Total	197	314	221	221	221							
Volume Left	0	203	0	0	0							
Volume Right	76	0	0	0	0							
cSH	110	1401	1700	1700	1700							
Volume to Capacity	1.79	0.15	0.13	0.13	0.13							
Queue Length 95th (m)	118.2	3.9	0.0	0.0	0.0							
Control Delay (s)	454.0	5.6	0.0	0.0	0.0							
Lane LOS	F	A										
Approach Delay (s)	454.0	1.8										
Approach LOS	F											
<b>Intersection Summary</b>												
Average Delay			77.7									
Intersection Capacity Utilization			34.9%	ICU Level of Service	A							
Analysis Period (min)			15									

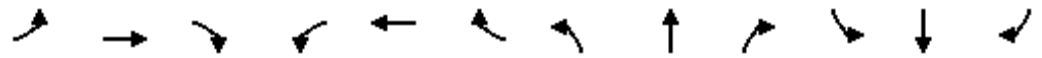

Lane Group	EBL	EBT	EBR	WBL	WBT	WBR	NBL	NBT	NBR	SBL	SBT	SBR
Lane Configurations					↑	↗		↖↖↖				
Ideal Flow (vphpl)	1750	1750	1750	1750	1750	1750	1750	1750	1750	1750	1750	1750
Storage Length (m)	0.0		0.0	0.0		15.0	0.0		0.0	0.0		0.0
Storage Lanes	0		0	0		1	0		0	0		0
Total Lost Time (s)	4.0	4.0	4.0	4.0	4.0	4.0	4.0	4.0	4.0	4.0	4.0	4.0
Turning Speed (k/h)	24		14	24		14	24		14	24		14
Lane Util. Factor	1.00	1.00	1.00	1.00	1.00	1.00	0.91	0.91	1.00	1.00	1.00	1.00
Ped Bike Factor						0.87		0.95				
Frt						0.850						
Flt Protected								0.982				
Satd. Flow (prot)	0	0	0	0	1697	1442	0	4548	0	0	0	0
Flt Permitted								0.982				
Satd. Flow (perm)	0	0	0	0	1697	1259	0	4326	0	0	0	0
Right Turn on Red			Yes			Yes	Yes		Yes			Yes
Satd. Flow (RTOR)						65		252				
Headway Factor	1.01	1.01	1.01	1.01	1.01	1.01	1.01	1.01	1.01	1.01	1.01	1.01
Link Speed (k/h)		50			50			50			50	
Link Distance (m)		182.2			96.8			83.3			76.7	
Travel Time (s)		13.1			7.0			6.0			5.5	
Volume (vph)	0	0	0	0	143	60	301	527	0	0	0	0
Confl. Peds. (#/hr)	54		59	59		54	112		267	267		112
Confl. Bikes (#/hr)						60						9
Peak Hour Factor	0.92	0.92	0.92	0.92	0.92	0.92	0.92	0.92	0.92	0.92	0.92	0.92
Adj. Flow (vph)	0	0	0	0	155	65	327	573	0	0	0	0
Lane Group Flow (vph)	0	0	0	0	155	65	0	900	0	0	0	0
Turn Type						Perm	Perm					
Protected Phases					8			2				
Permitted Phases						8	2					
Minimum Split (s)					19.0	19.0	30.0	30.0				
Total Split (s)	0.0	0.0	0.0	0.0	19.0	19.0	41.0	41.0	0.0	0.0	0.0	0.0
Total Split (%)	0.0%	0.0%	0.0%	0.0%	31.7%	31.7%	68.3%	68.3%	0.0%	0.0%	0.0%	0.0%
Maximum Green (s)					14.0	14.0	36.0	36.0				
Yellow Time (s)					3.3	3.3	3.3	3.3				
All-Red Time (s)					1.7	1.7	1.7	1.7				
Lead/Lag												
Lead-Lag Optimize?												
Walk Time (s)					7.0	7.0	19.0	19.0				
Flash Dont Walk (s)					7.0	7.0	6.0	6.0				
Pedestrian Calls (#/hr)					20	20	40	40				
Act Effct Green (s)					15.0	15.0		37.0				
Actuated g/C Ratio					0.25	0.25		0.62				
v/c Ratio					0.37	0.18		0.33				
Control Delay					21.6	7.0		4.2				
Queue Delay					0.0	0.0		0.0				
Total Delay					21.6	7.0		4.2				
LOS					C	A		A				
Approach Delay					17.3			4.2				
Approach LOS					B			A				

Intersection Summary

Area Type:	Other		
Cycle Length:	60		
Actuated Cycle Length:	60		
Offset:	33 (55%), Referenced to phase 2:NBTL and 6:., Start of Green		
Natural Cycle:	50		
Control Type:	Pretimed		
Maximum v/c Ratio:	0.37		
Intersection Signal Delay:	6.7	Intersection LOS:	A
Intersection Capacity Utilization	39.2%	ICU Level of Service	A
Analysis Period (min)	15		

Splits and Phases: 15: Gloucester & Metcalfe

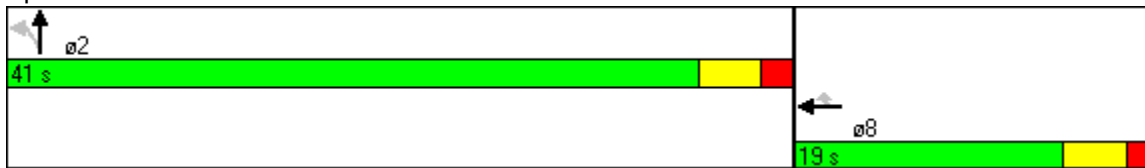



Lane Group	EBL	EBT	EBR	WBL	WBT	WBR	NBL	NBT	NBR	SBL	SBT	SBR
Lane Configurations				↙	↘						↑↑↑	
Ideal Flow (vphpl)	1750	1750	1750	1750	1750	1750	1750	1750	1750	1750	1750	1750
Storage Length (m)	0.0		0.0	15.0		0.0	0.0		0.0	0.0		0.0
Storage Lanes	0		0	1		0	0		0	0		0
Total Lost Time (s)	4.0	4.0	4.0	4.0	4.0	4.0	4.0	4.0	4.0	4.0	4.0	4.0
Turning Speed (k/h)	24		14	24		14	24		14	24		14
Lane Util. Factor	1.00	1.00	1.00	1.00	1.00	1.00	1.00	1.00	1.00	1.00	0.86	0.86
Ped Bike Factor				0.96							0.95	
Frt											0.962	
Flt Protected				0.950								
Satd. Flow (prot)	0	0	0	1612	1697	0	0	0	0	0	5361	0
Flt Permitted				0.950								
Satd. Flow (perm)	0	0	0	1540	1697	0	0	0	0	0	5361	0
Right Turn on Red			Yes	Yes		Yes			Yes			Yes
Satd. Flow (RTOR)				130							101	
Headway Factor	1.01	1.01	1.01	1.01	1.01	1.01	1.01	1.01	1.01	1.01	1.01	1.01
Link Speed (k/h)		50			50			50			50	
Link Distance (m)		108.3			182.2			82.4			78.3	
Travel Time (s)		7.8			13.1			5.9			5.6	
Volume (vph)	0	0	0	225	190	0	0	0	0	0	504	171
Confl. Peds. (#/hr)	198		37	37		198	105		138	138		105
Confl. Bikes (#/hr)			34			1						29
Peak Hour Factor	0.92	0.92	0.92	0.92	0.92	0.92	0.92	0.92	0.92	0.92	0.92	0.92
Adj. Flow (vph)	0	0	0	245	207	0	0	0	0	0	548	186
Lane Group Flow (vph)	0	0	0	245	207	0	0	0	0	0	734	0
Turn Type				Perm								
Protected Phases					8						6	
Permitted Phases				8								
Minimum Split (s)				25.0	25.0						35.0	
Total Split (s)	0.0	0.0	0.0	25.0	25.0	0.0	0.0	0.0	0.0	0.0	35.0	0.0
Total Split (%)	0.0%	0.0%	0.0%	41.7%	41.7%	0.0%	0.0%	0.0%	0.0%	0.0%	58.3%	0.0%
Maximum Green (s)				19.7	19.7						29.9	
Yellow Time (s)				3.3	3.3						3.3	
All-Red Time (s)				2.0	2.0						1.8	
Lead/Lag												
Lead-Lag Optimize?												
Walk Time (s)				7.0	7.0						15.0	
Flash Dont Walk (s)				8.0	8.0						7.0	
Pedestrian Calls (#/hr)				20	20						40	
Act Effct Green (s)				21.0	21.0						31.0	
Actuated g/C Ratio				0.35	0.35						0.52	
v/c Ratio				0.39	0.35						0.26	
Control Delay				6.2	13.0						7.2	
Queue Delay				0.0	0.0						0.0	
Total Delay				6.2	13.0						7.2	
LOS				A	B						A	
Approach Delay					9.3						7.2	
Approach LOS					A						A	



Intersection Summary

Area Type:	Other		
Cycle Length:	60		
Actuated Cycle Length:	60		
Offset:	1 (2%), Referenced to phase 2: and 6:SBT, Start of Green		
Natural Cycle:	60		
Control Type:	Pretimed		
Maximum v/c Ratio:	0.39		
Intersection Signal Delay:	8.0	Intersection LOS:	A
Intersection Capacity Utilization	39.2%	ICU Level of Service	A
Analysis Period (min)	15		

Splits and Phases: 16: Gloucester & O'Connor



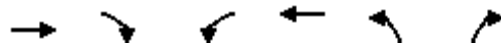

Movement	EBT	EBR	WBL	WBT	NBL	NBR
Lane Configurations	↶					↷
Sign Control	Free			Free	Stop	
Grade	0%			0%	0%	
Volume (veh/h)	229	11	0	0	0	22
Peak Hour Factor	0.92	0.92	0.92	0.92	0.92	0.92
Hourly flow rate (vph)	249	12	0	0	0	24
Pedestrians						
Lane Width (m)						
Walking Speed (m/s)						
Percent Blockage						
Right turn flare (veh)						
Median type	None					
Median storage (veh)						
Upstream signal (m)						
pX, platoon unblocked						
vC, conflicting volume			261		255	255
vC1, stage 1 conf vol						
vC2, stage 2 conf vol						
vCu, unblocked vol			261		255	255
tC, single (s)			4.1		6.4	6.2
tC, 2 stage (s)						
tF (s)			2.2		3.5	3.3
p0 queue free %			100		100	97
cM capacity (veh/h)			1304		734	784

Direction, Lane #	EB 1	NB 1
Volume Total	261	24
Volume Left	0	0
Volume Right	12	24
cSH	1700	784
Volume to Capacity	0.15	0.03
Queue Length 95th (m)	0.0	0.7
Control Delay (s)	0.0	9.7
Lane LOS		A
Approach Delay (s)	0.0	9.7
Approach LOS		A

Intersection Summary			
Average Delay		0.8	
Intersection Capacity Utilization	23.8%	ICU Level of Service	A
Analysis Period (min)		15	



Movement	EBL	EBT	EBR	WBL	WBT	WBR	NBL	NBT	NBR	SBL	SBT	SBR
Lane Configurations	↘	↑						↑↑↑				
Sign Control		Stop			Stop			Free			Free	
Grade		0%			0%			0%			0%	
Volume (veh/h)	185	153	0	0	0	0	0	502	237	0	0	0
Peak Hour Factor	0.92	0.92	0.92	0.92	0.92	0.92	0.92	0.92	0.92	0.92	0.92	0.92
Hourly flow rate (vph)	201	166	0	0	0	0	0	546	258	0	0	0
Pedestrians		232			146			40			40	
Lane Width (m)		3.5			0.0			3.5			0.0	
Walking Speed (m/s)		1.2			1.2			1.2			1.2	
Percent Blockage		19			0			3			0	
Right turn flare (veh)												
Median type		None			None							
Median storage veh												
Upstream signal (m)											83	
pX, platoon unblocked												
vC, conflicting volume	454	1181	272	944	1052	497	232			949		
vC1, stage 1 conf vol												
vC2, stage 2 conf vol												
vCu, unblocked vol	454	1181	272	944	1052	497	232			949		
tC, single (s)	7.5	6.5	6.9	7.5	6.5	6.9	4.1			4.1		
tC, 2 stage (s)												
tF (s)	3.5	4.0	3.3	3.5	4.0	3.3	2.2			2.2		
p0 queue free %	41	0	100	0	100	100	100			100		
cM capacity (veh/h)	340	153	570	0	183	519	1082			719		
<b>Direction, Lane #</b>	<b>EB 1</b>	<b>EB 2</b>	<b>NB 1</b>	<b>NB 2</b>	<b>NB 3</b>							
Volume Total	201	166	218	218	367							
Volume Left	201	0	0	0	0							
Volume Right	0	0	0	0	258							
cSH	340	153	1700	1700	1700							
Volume to Capacity	0.59	1.09	0.13	0.13	0.22							
Queue Length 95th (m)	27.3	66.6	0.0	0.0	0.0							
Control Delay (s)	29.8	156.8	0.0	0.0	0.0							
Lane LOS	D	F										
Approach Delay (s)	87.3		0.0									
Approach LOS	F											
<b>Intersection Summary</b>												
Average Delay			27.4									
Intersection Capacity Utilization			37.3%	ICU Level of Service	A							
Analysis Period (min)			15									

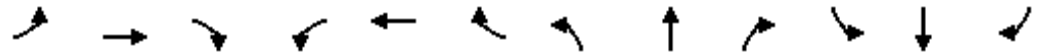

Movement	EBL	EBT	EBR	WBL	WBT	WBR	NBL	NBT	NBR	SBL	SBT	SBR
Lane Configurations		↑	↗								↑↑↑	
Sign Control		Stop			Stop			Free			Free	
Grade		0%			0%			0%			0%	
Volume (veh/h)	0	132	141	0	0	0	0	0	0	224	1162	0
Peak Hour Factor	0.92	0.92	0.92	0.92	0.92	0.92	0.92	0.92	0.92	0.92	0.92	0.92
Hourly flow rate (vph)	0	143	153	0	0	0	0	0	0	243	1263	0
Pedestrians		186			108			19			13	
Lane Width (m)		3.5			0.0			0.0			3.5	
Walking Speed (m/s)		1.2			1.2			1.2			1.2	
Percent Blockage		15			0			0			1	
Right turn flare (veh)			2									
Median type		None			None							
Median storage veh												
Upstream signal (m)											82	
pX, platoon unblocked	0.94	0.94	0.94	0.94	0.94		0.94					
vC, conflicting volume	1949	2044	521	1078	2044	121	1449			108		
vC1, stage 1 conf vol												
vC2, stage 2 conf vol												
vCu, unblocked vol	1813	1915	291	885	1915	121	1280			108		
tC, single (s)	7.5	6.5	6.9	7.5	6.5	6.9	4.1			4.1		
tC, 2 stage (s)												
tF (s)	3.5	4.0	3.3	3.5	4.0	3.3	2.2			2.2		
p0 queue free %	100	0	73	0	100	100	100			84		
cM capacity (veh/h)	30	45	562	0	45	898	429			1480		

Direction, Lane #	EB 1	SB 1	SB 2	SB 3	SB 4
Volume Total	297	424	361	361	361
Volume Left	0	243	0	0	0
Volume Right	153	0	0	0	0
cSH	85	1480	1700	1700	1700
Volume to Capacity	3.48	0.16	0.21	0.21	0.21
Queue Length 95th (m)	Err	4.5	0.0	0.0	0.0
Control Delay (s)	Err	5.2	0.0	0.0	0.0
Lane LOS	F	A			
Approach Delay (s)	Err	1.5			
Approach LOS	F				

Intersection Summary		
Average Delay		1646.6
Intersection Capacity Utilization	40.9%	ICU Level of Service A
Analysis Period (min)		15



Lane Group	EBL	EBT	EBR	WBL	WBT	WBR	NBL	NBT	NBR	SBL	SBT	SBR
Lane Configurations					↑	↗		↖↖↖				
Ideal Flow (vphpl)	1750	1750	1750	1750	1750	1750	1750	1750	1750	1750	1750	1750
Storage Length (m)	0.0		0.0	0.0		15.0	0.0		0.0	0.0		0.0
Storage Lanes	0		0	0		1	0		0	0		0
Total Lost Time (s)	4.0	4.0	4.0	4.0	4.0	4.0	4.0	4.0	4.0	4.0	4.0	4.0
Turning Speed (k/h)	24		14	24		14	24		14	24		14
Lane Util. Factor	1.00	1.00	1.00	1.00	1.00	1.00	0.91	0.91	1.00	1.00	1.00	1.00
Ped Bike Factor						0.87		0.95				
Frt						0.850						
Flt Protected								0.983				
Satd. Flow (prot)	0	0	0	0	1697	1442	0	4553	0	0	0	0
Flt Permitted								0.983				
Satd. Flow (perm)	0	0	0	0	1697	1259	0	4341	0	0	0	0
Right Turn on Red			Yes			Yes	Yes		Yes			Yes
Satd. Flow (RTOR)						109		170				
Headway Factor	1.01	1.01	1.01	1.01	1.01	1.01	1.01	1.01	1.01	1.01	1.01	1.01
Link Speed (k/h)		50			50			50			50	
Link Distance (m)		182.2			96.8			83.3			76.7	
Travel Time (s)		13.1			7.0			6.0			5.5	
Volume (vph)	0	0	0	0	209	100	217	409	0	0	0	0
Confl. Peds. (#/hr)	54		59	59		54	112		267	267		112
Confl. Bikes (#/hr)						60						9
Peak Hour Factor	0.92	0.92	0.92	0.92	0.92	0.92	0.92	0.92	0.92	0.92	0.92	0.92
Adj. Flow (vph)	0	0	0	0	227	109	236	445	0	0	0	0
Lane Group Flow (vph)	0	0	0	0	227	109	0	681	0	0	0	0
Turn Type						Perm	Perm					
Protected Phases					8			2				
Permitted Phases						8	2					
Minimum Split (s)					19.0	19.0	30.0	30.0				
Total Split (s)	0.0	0.0	0.0	0.0	19.0	19.0	41.0	41.0	0.0	0.0	0.0	0.0
Total Split (%)	0.0%	0.0%	0.0%	0.0%	31.7%	31.7%	68.3%	68.3%	0.0%	0.0%	0.0%	0.0%
Maximum Green (s)					14.0	14.0	36.0	36.0				
Yellow Time (s)					3.3	3.3	3.3	3.3				
All-Red Time (s)					1.7	1.7	1.7	1.7				
Lead/Lag												
Lead-Lag Optimize?												
Walk Time (s)					7.0	7.0	19.0	19.0				
Flash Dont Walk (s)					7.0	7.0	6.0	6.0				
Pedestrian Calls (#/hr)					20	20	40	40				
Act Effct Green (s)					15.0	15.0		37.0				
Actuated g/C Ratio					0.25	0.25		0.62				
v/c Ratio					0.54	0.27		0.25				
Control Delay					25.0	6.6		4.1				
Queue Delay					0.0	0.0		0.0				
Total Delay					25.0	6.6		4.1				
LOS					C	A		A				
Approach Delay					19.0			4.1				
Approach LOS					B			A				

Intersection Summary

Area Type:	Other
Cycle Length:	60
Actuated Cycle Length:	60
Offset:	33 (55%), Referenced to phase 2:NBTL and 6:., Start of Green
Natural Cycle:	50
Control Type:	Pretimed
Maximum v/c Ratio:	0.54
Intersection Signal Delay:	9.0
Intersection LOS:	A
Intersection Capacity Utilization	39.4%
ICU Level of Service	A
Analysis Period (min)	15

Splits and Phases: 15: Gloucester & Metcalfe

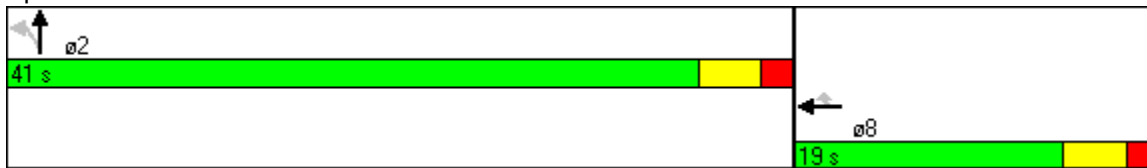



Lane Group	EBL	EBT	EBR	WBL	WBT	WBR	NBL	NBT	NBR	SBL	SBT	SBR
Lane Configurations				↙	↘						↑↑↑	
Ideal Flow (vphpl)	1750	1750	1750	1750	1750	1750	1750	1750	1750	1750	1750	1750
Storage Length (m)	0.0		0.0	15.0		0.0	0.0		0.0	0.0		0.0
Storage Lanes	0		0	1		0	0		0	0		0
Total Lost Time (s)	4.0	4.0	4.0	4.0	4.0	4.0	4.0	4.0	4.0	4.0	4.0	4.0
Turning Speed (k/h)	24		14	24		14	24		14	24		14
Lane Util. Factor	1.00	1.00	1.00	1.00	1.00	1.00	1.00	1.00	1.00	1.00	0.86	0.86
Ped Bike Factor				0.96							0.98	
Frt											0.984	
Flt Protected				0.950								
Satd. Flow (prot)	0	0	0	1612	1697	0	0	0	0	0	5634	0
Flt Permitted				0.950								
Satd. Flow (perm)	0	0	0	1540	1697	0	0	0	0	0	5634	0
Right Turn on Red			Yes	Yes		Yes			Yes			Yes
Satd. Flow (RTOR)				40							72	
Headway Factor	1.01	1.01	1.01	1.01	1.01	1.01	1.01	1.01	1.01	1.01	1.01	1.01
Link Speed (k/h)		50			50			50			50	
Link Distance (m)		108.3			182.2			82.4			78.3	
Travel Time (s)		7.8			13.1			5.9			5.6	
Volume (vph)	0	0	0	312	206	0	0	0	0	0	903	108
Confl. Peds. (#/hr)	198		37	37		198	105		138	138		105
Confl. Bikes (#/hr)			34			1						29
Peak Hour Factor	0.92	0.92	0.92	0.92	0.92	0.92	0.92	0.92	0.92	0.92	0.92	0.92
Adj. Flow (vph)	0	0	0	339	224	0	0	0	0	0	982	117
Lane Group Flow (vph)	0	0	0	339	224	0	0	0	0	0	1099	0
Turn Type				Perm								
Protected Phases					8						6	
Permitted Phases				8								
Minimum Split (s)				25.0	25.0						35.0	
Total Split (s)	0.0	0.0	0.0	25.0	25.0	0.0	0.0	0.0	0.0	0.0	35.0	0.0
Total Split (%)	0.0%	0.0%	0.0%	41.7%	41.7%	0.0%	0.0%	0.0%	0.0%	0.0%	58.3%	0.0%
Maximum Green (s)				19.7	19.7						29.9	
Yellow Time (s)				3.3	3.3						3.3	
All-Red Time (s)				2.0	2.0						1.8	
Lead/Lag												
Lead-Lag Optimize?												
Walk Time (s)				7.0	7.0						15.0	
Flash Dont Walk (s)				8.0	8.0						7.0	
Pedestrian Calls (#/hr)				20	20						40	
Act Effct Green (s)				21.0	21.0						31.0	
Actuated g/C Ratio				0.35	0.35						0.52	
v/c Ratio				0.60	0.38						0.37	
Control Delay				15.4	13.0						8.5	
Queue Delay				0.0	0.0						0.0	
Total Delay				15.4	13.0						8.5	
LOS				B	B						A	
Approach Delay					14.4						8.5	
Approach LOS					B						A	

Intersection Summary

Area Type:	Other		
Cycle Length:	60		
Actuated Cycle Length:	60		
Offset:	1 (2%), Referenced to phase 2: and 6:SBT, Start of Green		
Natural Cycle:	60		
Control Type:	Pretimed		
Maximum v/c Ratio:	0.60		
Intersection Signal Delay:	10.5	Intersection LOS:	B
Intersection Capacity Utilization	43.8%	ICU Level of Service	A
Analysis Period (min)	15		

Splits and Phases: 16: Gloucester & O'Connor





	→	↘	↙	←	↖	↗
Movement	EBT	EBR	WBL	WBT	NBL	NBR
Lane Configurations	↗					↖
Sign Control	Free			Free	Stop	
Grade	0%			0%	0%	
Volume (veh/h)	331	34	0	0	0	48
Peak Hour Factor	0.92	0.92	0.92	0.92	0.92	0.92
Hourly flow rate (vph)	360	37	0	0	0	52
Pedestrians						
Lane Width (m)						
Walking Speed (m/s)						
Percent Blockage						
Right turn flare (veh)						
Median type	None					
Median storage (veh)						
Upstream signal (m)						
pX, platoon unblocked						
vC, conflicting volume			397		378	378
vC1, stage 1 conf vol						
vC2, stage 2 conf vol						
vCu, unblocked vol			397		378	378
tC, single (s)			4.1		6.4	6.2
tC, 2 stage (s)						
tF (s)			2.2		3.5	3.3
p0 queue free %			100		100	92
cM capacity (veh/h)			1162		624	668
<b>Direction, Lane #</b>	<b>EB 1</b>	<b>NB 1</b>				
Volume Total	397	52				
Volume Left	0	0				
Volume Right	37	52				
cSH	1700	668				
Volume to Capacity	0.23	0.08				
Queue Length 95th (m)	0.0	1.9				
Control Delay (s)	0.0	10.8				
Lane LOS		B				
Approach Delay (s)	0.0	10.8				
Approach LOS		B				
<b>Intersection Summary</b>						
Average Delay			1.3			
Intersection Capacity Utilization			31.2%		ICU Level of Service	A
Analysis Period (min)			15			



Lane Group	EBL	EBT	EBR	WBL	WBT	WBR	NBL	NBT	NBR	SBL	SBT	SBR
Lane Configurations												
Ideal Flow (vphpl)	1750	1750	1750	1750	1750	1750	1750	1750	1750	1750	1750	1750
Storage Length (m)	15.0		0.0	0.0		0.0	0.0		0.0	0.0		0.0
Storage Lanes	1		0	0		0	0		0	0		0
Total Lost Time (s)	4.0	4.0	4.0	4.0	4.0	4.0	4.0	4.0	4.0	4.0	4.0	4.0
Turning Speed (k/h)	24		14	24		14	24		14	24		14
Lane Util. Factor	1.00	1.00	1.00	1.00	1.00	1.00	1.00	0.91	0.91	1.00	1.00	1.00
Ped Bike Factor	0.95							0.94				
Frt								0.968				
Flt Protected	0.950											
Satd. Flow (prot)	1612	1697	0	0	0	0	0	4202	0	0	0	0
Flt Permitted	0.950											
Satd. Flow (perm)	1529	1697	0	0	0	0	0	4202	0	0	0	0
Right Turn on Red	Yes		Yes			Yes			Yes			Yes
Satd. Flow (RTOR)	15							174				
Headway Factor	1.01	1.01	1.01	1.01	1.01	1.01	1.01	1.01	1.01	1.01	1.01	1.01
Link Speed (k/h)		30			30			50			50	
Link Distance (m)		82.2			94.2			73.5			83.3	
Travel Time (s)		9.9			11.3			5.3			6.0	
Volume (vph)	182	132	0	0	0	0	0	917	248	0	0	0
Confl. Peds. (#/hr)	40		40	40		40	330		225	225		330
Confl. Bikes (#/hr)						78			19			
Peak Hour Factor	0.92	0.92	0.92	0.92	0.92	0.92	0.92	0.92	0.92	0.92	0.92	0.92
Adj. Flow (vph)	198	143	0	0	0	0	0	997	270	0	0	0
Lane Group Flow (vph)	198	143	0	0	0	0	0	1267	0	0	0	0
Turn Type	Perm											
Protected Phases		4						2				
Permitted Phases	4											
Minimum Split (s)	23.0	23.0						35.0				
Total Split (s)	24.0	24.0	0.0	0.0	0.0	0.0	0.0	36.0	0.0	0.0	0.0	0.0
Total Split (%)	40.0%	40.0%	0.0%	0.0%	0.0%	0.0%	0.0%	60.0%	0.0%	0.0%	0.0%	0.0%
Maximum Green (s)	19.0	19.0						31.0				
Yellow Time (s)	3.3	3.3						3.3				
All-Red Time (s)	1.7	1.7						1.7				
Lead/Lag												
Lead-Lag Optimize?												
Walk Time (s)	7.0	7.0						19.0				
Flash Dont Walk (s)	7.0	7.0						6.0				
Pedestrian Calls (#/hr)	0	0						0				
Act Effct Green (s)	20.0	20.0						32.0				
Actuated g/C Ratio	0.33	0.33						0.53				
v/c Ratio	0.38	0.25						0.55				
Control Delay	18.3	17.5						8.8				
Queue Delay	0.0	0.0						0.0				
Total Delay	18.3	17.5						8.8				
LOS	B	B						A				
Approach Delay		18.0						8.8				
Approach LOS		B						A				

Intersection Summary

Area Type:	Other		
Cycle Length:	60		
Actuated Cycle Length:	60		
Offset:	26 (43%), Referenced to phase 2:NBT and 6:, Start of Green		
Natural Cycle:	60		
Control Type:	Pretimed		
Maximum v/c Ratio:	0.55		
Intersection Signal Delay:	10.8	Intersection LOS:	B
Intersection Capacity Utilization	45.3%	ICU Level of Service	A
Analysis Period (min)	15		

Splits and Phases: 1: Nepean & Metcalfe

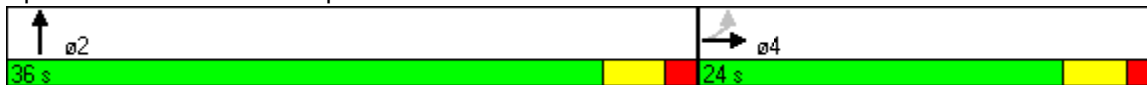

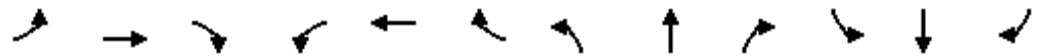

Lane Group	EBL	EBT	EBR	WBL	WBT	WBR	NBL	NBT	NBR	SBL	SBT	SBR
Lane Configurations		↑	↗								↑↑↑	
Ideal Flow (vphpl)	1750	1750	1750	1750	1750	1750	1750	1750	1750	1750	1750	1750
Storage Length (m)	0.0		15.0	0.0		0.0	0.0		0.0	0.0		0.0
Storage Lanes	0		1	0		0	0		0	0		0
Total Lost Time (s)	4.0	4.0	4.0	4.0	4.0	4.0	4.0	4.0	4.0	4.0	4.0	4.0
Turning Speed (k/h)	24		14	24		14	24		14	24		14
Lane Util. Factor	1.00	1.00	1.00	1.00	1.00	1.00	1.00	1.00	1.00	0.86	0.86	1.00
Ped Bike Factor			0.95								0.95	
Frt			0.850									
Flt Protected											0.990	
Satd. Flow (prot)	0	1697	1442	0	0	0	0	0	0	0	5778	0
Flt Permitted											0.990	
Satd. Flow (perm)	0	1697	1372	0	0	0	0	0	0	0	5495	0
Right Turn on Red			Yes			Yes			Yes	Yes		Yes
Satd. Flow (RTOR)			36								158	
Headway Factor	1.01	1.01	1.01	1.01	1.01	1.01	1.01	1.01	1.01	1.01	1.01	1.01
Link Speed (k/h)		30			30			50			50	
Link Distance (m)		109.5			95.0			73.8			82.4	
Travel Time (s)		13.1			11.4			5.3			5.9	
Volume (vph)	0	111	70	0	0	0	0	0	0	187	711	0
Confl. Peds. (#/hr)	32		25	25		32	237		173	173		237
Confl. Bikes (#/hr)			12			1			13			
Peak Hour Factor	0.92	0.92	0.92	0.92	0.92	0.92	0.92	0.92	0.92	0.92	0.92	0.92
Adj. Flow (vph)	0	121	76	0	0	0	0	0	0	203	773	0
Lane Group Flow (vph)	0	121	76	0	0	0	0	0	0	0	976	0
Turn Type			Perm							Perm		
Protected Phases		4									6	
Permitted Phases			4							6		
Minimum Split (s)		23.3	23.3							31.1	31.1	
Total Split (s)	0.0	26.0	26.0	0.0	0.0	0.0	0.0	0.0	0.0	34.0	34.0	0.0
Total Split (%)	0.0%	43.3%	43.3%	0.0%	0.0%	0.0%	0.0%	0.0%	0.0%	56.7%	56.7%	0.0%
Maximum Green (s)		20.7	20.7							28.9	28.9	
Yellow Time (s)		3.3	3.3							3.3	3.3	
All-Red Time (s)		2.0	2.0							1.8	1.8	
Lead/Lag												
Lead-Lag Optimize?												
Walk Time (s)		7.0	7.0							15.0	15.0	
Flash Dont Walk (s)		8.0	8.0							7.0	7.0	
Pedestrian Calls (#/hr)		0	0							0	0	
Act Effct Green (s)		22.0	22.0							30.0	30.0	
Actuated g/C Ratio		0.37	0.37							0.50	0.50	
v/c Ratio		0.19	0.14							0.35	0.35	
Control Delay		14.0	8.7							5.6	5.6	
Queue Delay		0.0	0.0							0.0	0.0	
Total Delay		14.0	8.7							5.6	5.6	
LOS		B	A							A	A	
Approach Delay		12.0								5.6	5.6	
Approach LOS		B								A	A	

Intersection Summary

Area Type:	Other
Cycle Length:	60
Actuated Cycle Length:	60
Offset:	7 (12%), Referenced to phase 2: and 6:SBTL, Start of Green
Natural Cycle:	55
Control Type:	Pretimed
Maximum v/c Ratio:	0.35
Intersection Signal Delay:	6.7
Intersection LOS:	A
Intersection Capacity Utilization	37.5%
ICU Level of Service	A
Analysis Period (min)	15

Splits and Phases: 13: Nepean & O'Connor





Lane Group	EBL	EBT	EBR	WBL	WBT	WBR	NBL	NBT	NBR	SBL	SBT	SBR
Lane Configurations					↑	↗		↖↖↖				
Ideal Flow (vphpl)	1750	1750	1750	1750	1750	1750	1750	1750	1750	1750	1750	1750
Storage Length (m)	0.0		0.0	0.0		15.0	0.0		0.0	0.0		0.0
Storage Lanes	0		0	0		1	0		0	0		0
Total Lost Time (s)	4.0	4.0	4.0	4.0	4.0	4.0	4.0	4.0	4.0	4.0	4.0	4.0
Turning Speed (k/h)	24		14	24		14	24		14	24		14
Lane Util. Factor	1.00	1.00	1.00	1.00	1.00	1.00	0.91	0.91	1.00	1.00	1.00	1.00
Ped Bike Factor						0.87		0.95				
Frt						0.850						
Flt Protected								0.982				
Satd. Flow (prot)	0	0	0	0	1697	1442	0	4548	0	0	0	0
Flt Permitted								0.982				
Satd. Flow (perm)	0	0	0	0	1697	1259	0	4326	0	0	0	0
Right Turn on Red			Yes			Yes	Yes		Yes			Yes
Satd. Flow (RTOR)						65		252				
Headway Factor	1.01	1.01	1.01	1.01	1.01	1.01	1.01	1.01	1.01	1.01	1.01	1.01
Link Speed (k/h)		50			50			50			50	
Link Distance (m)		182.2			96.8			83.3			76.7	
Travel Time (s)		13.1			7.0			6.0			5.5	
Volume (vph)	0	0	0	0	143	60	301	527	0	0	0	0
Confl. Peds. (#/hr)	54		59	59		54	112		267	267		112
Confl. Bikes (#/hr)						60						9
Peak Hour Factor	0.92	0.92	0.92	0.92	0.92	0.92	0.92	0.92	0.92	0.92	0.92	0.92
Adj. Flow (vph)	0	0	0	0	155	65	327	573	0	0	0	0
Lane Group Flow (vph)	0	0	0	0	155	65	0	900	0	0	0	0
Turn Type						Perm	Perm					
Protected Phases					8			2				
Permitted Phases						8	2					
Minimum Split (s)					19.0	19.0	30.0	30.0				
Total Split (s)	0.0	0.0	0.0	0.0	19.0	19.0	41.0	41.0	0.0	0.0	0.0	0.0
Total Split (%)	0.0%	0.0%	0.0%	0.0%	31.7%	31.7%	68.3%	68.3%	0.0%	0.0%	0.0%	0.0%
Maximum Green (s)					14.0	14.0	36.0	36.0				
Yellow Time (s)					3.3	3.3	3.3	3.3				
All-Red Time (s)					1.7	1.7	1.7	1.7				
Lead/Lag												
Lead-Lag Optimize?												
Walk Time (s)					7.0	7.0	19.0	19.0				
Flash Dont Walk (s)					7.0	7.0	6.0	6.0				
Pedestrian Calls (#/hr)					20	20	40	40				
Act Effct Green (s)					15.0	15.0		37.0				
Actuated g/C Ratio					0.25	0.25		0.62				
v/c Ratio					0.37	0.18		0.33				
Control Delay					21.6	7.0		1.8				
Queue Delay					0.0	0.0		0.1				
Total Delay					21.6	7.0		1.9				
LOS					C	A		A				
Approach Delay					17.3			1.9				
Approach LOS					B			A				

Intersection Summary

Area Type:	Other		
Cycle Length:	60		
Actuated Cycle Length:	60		
Offset:	33 (55%), Referenced to phase 2:NBTL and 6:., Start of Green		
Natural Cycle:	50		
Control Type:	Pretimed		
Maximum v/c Ratio:	0.37		
Intersection Signal Delay:	4.9	Intersection LOS:	A
Intersection Capacity Utilization	39.2%	ICU Level of Service	A
Analysis Period (min)	15		

Splits and Phases: 15: Gloucester & Metcalfe

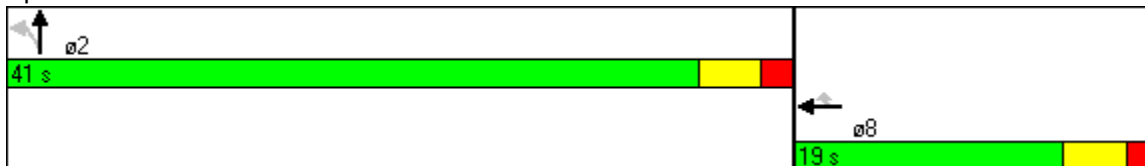



Lane Group	EBL	EBT	EBR	WBL	WBT	WBR	NBL	NBT	NBR	SBL	SBT	SBR
Lane Configurations				↙	↘						↑↑↑	
Ideal Flow (vphpl)	1750	1750	1750	1750	1750	1750	1750	1750	1750	1750	1750	1750
Storage Length (m)	0.0		0.0	15.0		0.0	0.0		0.0	0.0		0.0
Storage Lanes	0		0	1		0	0		0	0		0
Total Lost Time (s)	4.0	4.0	4.0	4.0	4.0	4.0	4.0	4.0	4.0	4.0	4.0	4.0
Turning Speed (k/h)	24		14	24		14	24		14	24		14
Lane Util. Factor	1.00	1.00	1.00	1.00	1.00	1.00	1.00	1.00	1.00	1.00	0.86	0.86
Ped Bike Factor				0.96							0.95	
Frt											0.962	
Flt Protected				0.950								
Satd. Flow (prot)	0	0	0	1612	1697	0	0	0	0	0	5361	0
Flt Permitted				0.950								
Satd. Flow (perm)	0	0	0	1540	1697	0	0	0	0	0	5361	0
Right Turn on Red			Yes	Yes		Yes			Yes			Yes
Satd. Flow (RTOR)				130							101	
Headway Factor	1.01	1.01	1.01	1.01	1.01	1.01	1.01	1.01	1.01	1.01	1.01	1.01
Link Speed (k/h)		50			50			50			50	
Link Distance (m)		108.3			182.2			82.4			78.3	
Travel Time (s)		7.8			13.1			5.9			5.6	
Volume (vph)	0	0	0	225	190	0	0	0	0	0	504	171
Confl. Peds. (#/hr)	198		37	37		198	105		138	138		105
Confl. Bikes (#/hr)			34			1						29
Peak Hour Factor	0.92	0.92	0.92	0.92	0.92	0.92	0.92	0.92	0.92	0.92	0.92	0.92
Adj. Flow (vph)	0	0	0	245	207	0	0	0	0	0	548	186
Lane Group Flow (vph)	0	0	0	245	207	0	0	0	0	0	734	0
Turn Type				Perm								
Protected Phases					8						6	
Permitted Phases				8								
Minimum Split (s)				25.0	25.0						35.0	
Total Split (s)	0.0	0.0	0.0	25.0	25.0	0.0	0.0	0.0	0.0	0.0	35.0	0.0
Total Split (%)	0.0%	0.0%	0.0%	41.7%	41.7%	0.0%	0.0%	0.0%	0.0%	0.0%	58.3%	0.0%
Maximum Green (s)				19.7	19.7						29.9	
Yellow Time (s)				3.3	3.3						3.3	
All-Red Time (s)				2.0	2.0						1.8	
Lead/Lag												
Lead-Lag Optimize?												
Walk Time (s)				7.0	7.0						15.0	
Flash Dont Walk (s)				8.0	8.0						7.0	
Pedestrian Calls (#/hr)				20	20						40	
Act Effct Green (s)				21.0	21.0						31.0	
Actuated g/C Ratio				0.35	0.35						0.52	
v/c Ratio				0.39	0.35						0.26	
Control Delay				5.6	11.9						7.2	
Queue Delay				0.0	0.0						0.0	
Total Delay				5.6	11.9						7.2	
LOS				A	B						A	
Approach Delay					8.5						7.2	
Approach LOS					A						A	



Intersection Summary

Area Type:	Other
Cycle Length:	60
Actuated Cycle Length:	60
Offset:	1 (2%), Referenced to phase 2: and 6:SBT, Start of Green
Natural Cycle:	60
Control Type:	Pretimed
Maximum v/c Ratio:	0.39
Intersection Signal Delay:	7.7
Intersection LOS:	A
Intersection Capacity Utilization	39.2%
ICU Level of Service	A
Analysis Period (min)	15

Splits and Phases: 16: Gloucester & O'Connor





Movement	EBT	EBR	WBL	WBT	NBL	NBR
Lane Configurations	↶					↷
Sign Control	Free			Free	Stop	
Grade	0%			0%	0%	
Volume (veh/h)	229	11	0	0	0	22
Peak Hour Factor	0.92	0.92	0.92	0.92	0.92	0.92
Hourly flow rate (vph)	249	12	0	0	0	24
Pedestrians						
Lane Width (m)						
Walking Speed (m/s)						
Percent Blockage						
Right turn flare (veh)						
Median type					None	
Median storage (veh)						
Upstream signal (m)	100			82		
pX, platoon unblocked						
vC, conflicting volume			261		255	255
vC1, stage 1 conf vol						
vC2, stage 2 conf vol						
vCu, unblocked vol			261		255	255
tC, single (s)			4.1		6.4	6.2
tC, 2 stage (s)						
tF (s)			2.2		3.5	3.3
p0 queue free %			100		100	97
cM capacity (veh/h)			1304		734	784

Direction, Lane #	EB 1	NB 1
Volume Total	261	24
Volume Left	0	0
Volume Right	12	24
cSH	1700	784
Volume to Capacity	0.15	0.03
Queue Length 95th (m)	0.0	0.7
Control Delay (s)	0.0	9.7
Lane LOS		A
Approach Delay (s)	0.0	9.7
Approach LOS		A

Intersection Summary			
Average Delay		0.8	
Intersection Capacity Utilization	23.8%	ICU Level of Service	A
Analysis Period (min)		15	



Lane Group	EBL	EBT	EBR	WBL	WBT	WBR	NBL	NBT	NBR	SBL	SBT	SBR
Lane Configurations												
Ideal Flow (vphpl)	1750	1750	1750	1750	1750	1750	1750	1750	1750	1750	1750	1750
Storage Length (m)	15.0		0.0	0.0		0.0	0.0		0.0	0.0		0.0
Storage Lanes	1		0	0		0	0		0	0		0
Total Lost Time (s)	4.0	4.0	4.0	4.0	4.0	4.0	4.0	4.0	4.0	4.0	4.0	4.0
Turning Speed (k/h)	24		14	24		14	24		14	24		14
Lane Util. Factor	1.00	1.00	1.00	1.00	1.00	1.00	1.00	0.91	0.91	1.00	1.00	1.00
Ped Bike Factor	0.95							0.91				
Frt								0.952				
Flt Protected	0.950											
Satd. Flow (prot)	1612	1697	0	0	0	0	0	3993	0	0	0	0
Flt Permitted	0.950											
Satd. Flow (perm)	1529	1697	0	0	0	0	0	3993	0	0	0	0
Right Turn on Red	Yes		Yes			Yes			Yes			Yes
Satd. Flow (RTOR)	50							258				
Headway Factor	1.01	1.01	1.01	1.01	1.01	1.01	1.01	1.01	1.01	1.01	1.01	1.01
Link Speed (k/h)		30			30			50				50
Link Distance (m)		83.2			94.2			73.5				83.3
Travel Time (s)		10.0			11.3			5.3				6.0
Volume (vph)	185	153	0	0	0	0	0	502	237	0	0	0
Confl. Peds. (#/hr)	40		40	40		40	330		225	225		330
Confl. Bikes (#/hr)						78			19			
Peak Hour Factor	0.92	0.92	0.92	0.92	0.92	0.92	0.92	0.92	0.92	0.92	0.92	0.92
Adj. Flow (vph)	201	166	0	0	0	0	0	546	258	0	0	0
Lane Group Flow (vph)	201	166	0	0	0	0	0	804	0	0	0	0
Turn Type	Perm											
Protected Phases		4						2				
Permitted Phases	4											
Minimum Split (s)	23.0	23.0						35.0				
Total Split (s)	24.0	24.0	0.0	0.0	0.0	0.0	0.0	36.0	0.0	0.0	0.0	0.0
Total Split (%)	40.0%	40.0%	0.0%	0.0%	0.0%	0.0%	0.0%	60.0%	0.0%	0.0%	0.0%	0.0%
Maximum Green (s)	19.0	19.0						31.0				
Yellow Time (s)	3.3	3.3						3.3				
All-Red Time (s)	1.7	1.7						1.7				
Lead/Lag												
Lead-Lag Optimize?												
Walk Time (s)	7.0	7.0						19.0				
Flash Dont Walk (s)	7.0	7.0						6.0				
Pedestrian Calls (#/hr)	0	0						0				
Act Effct Green (s)	20.0	20.0						32.0				
Actuated g/C Ratio	0.33	0.33						0.53				
v/c Ratio	0.37	0.29						0.36				
Control Delay	15.3	18.0						5.8				
Queue Delay	0.0	0.0						0.0				
Total Delay	15.3	18.0						5.8				
LOS	B	B						A				
Approach Delay		16.5						5.8				
Approach LOS		B						A				

Intersection Summary

Area Type:	Other		
Cycle Length:	60		
Actuated Cycle Length:	60		
Offset:	26 (43%), Referenced to phase 2:NBT and 6:, Start of Green		
Natural Cycle:	60		
Control Type:	Pretimed		
Maximum v/c Ratio:	0.37		
Intersection Signal Delay:	9.1	Intersection LOS:	A
Intersection Capacity Utilization	39.2%	ICU Level of Service	A
Analysis Period (min)	15		

Splits and Phases: 1: Nepean & Metcalfe

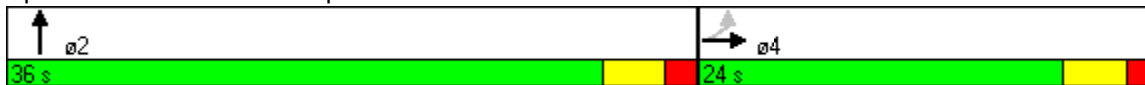

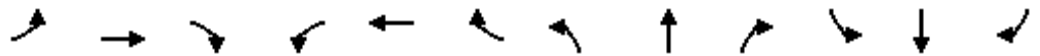

Lane Group	EBL	EBT	EBR	WBL	WBT	WBR	NBL	NBT	NBR	SBL	SBT	SBR
Lane Configurations		↑	↗								↑↑↑	
Ideal Flow (vphpl)	1750	1750	1750	1750	1750	1750	1750	1750	1750	1750	1750	1750
Storage Length (m)	0.0		15.0	0.0		0.0	0.0		0.0	0.0		0.0
Storage Lanes	0		1	0		0	0		0	0		0
Total Lost Time (s)	4.0	4.0	4.0	4.0	4.0	4.0	4.0	4.0	4.0	4.0	4.0	4.0
Turning Speed (k/h)	24		14	24		14	24		14	24		14
Lane Util. Factor	1.00	1.00	1.00	1.00	1.00	1.00	1.00	1.00	1.00	0.86	0.86	1.00
Ped Bike Factor			0.95								0.96	
Frt			0.850									
Flt Protected											0.992	
Satd. Flow (prot)	0	1697	1442	0	0	0	0	0	0	0	5790	0
Flt Permitted											0.992	
Satd. Flow (perm)	0	1697	1372	0	0	0	0	0	0	0	5569	0
Right Turn on Red			Yes			Yes			Yes	Yes		Yes
Satd. Flow (RTOR)			9								116	
Headway Factor	1.01	1.01	1.01	1.01	1.01	1.01	1.01	1.01	1.01	1.01	1.01	1.01
Link Speed (k/h)		30			30			50			50	
Link Distance (m)		109.5			95.0			73.8			82.4	
Travel Time (s)		13.1			11.4			5.3			5.9	
Volume (vph)	0	132	141	0	0	0	0	0	0	224	1162	0
Confl. Peds. (#/hr)	32		25	25		32	237		173	173		237
Confl. Bikes (#/hr)			12			1			13			
Peak Hour Factor	0.92	0.92	0.92	0.92	0.92	0.92	0.92	0.92	0.92	0.92	0.92	0.92
Adj. Flow (vph)	0	143	153	0	0	0	0	0	0	243	1263	0
Lane Group Flow (vph)	0	143	153	0	0	0	0	0	0	0	1506	0
Turn Type			Perm							Perm		
Protected Phases		4									6	
Permitted Phases			4							6		
Minimum Split (s)		23.3	23.3							31.1	31.1	
Total Split (s)	0.0	26.0	26.0	0.0	0.0	0.0	0.0	0.0	0.0	34.0	34.0	0.0
Total Split (%)	0.0%	43.3%	43.3%	0.0%	0.0%	0.0%	0.0%	0.0%	0.0%	56.7%	56.7%	0.0%
Maximum Green (s)		20.7	20.7							28.9	28.9	
Yellow Time (s)		3.3	3.3							3.3	3.3	
All-Red Time (s)		2.0	2.0							1.8	1.8	
Lead/Lag												
Lead-Lag Optimize?												
Walk Time (s)		7.0	7.0							15.0	15.0	
Flash Dont Walk (s)		8.0	8.0							7.0	7.0	
Pedestrian Calls (#/hr)		0	0							0	0	
Act Effct Green (s)		22.0	22.0							30.0	30.0	
Actuated g/C Ratio		0.37	0.37							0.50	0.50	
v/c Ratio		0.23	0.30							0.53	0.53	
Control Delay		14.4	14.7							7.8	7.8	
Queue Delay		0.0	0.0							0.1	0.1	
Total Delay		14.4	14.7							7.9	7.9	
LOS		B	B							A	A	
Approach Delay		14.6								7.9	7.9	
Approach LOS		B								A	A	

Intersection Summary

Area Type:	Other		
Cycle Length:	60		
Actuated Cycle Length:	60		
Offset:	7 (12%), Referenced to phase 2: and 6:SBTL, Start of Green		
Natural Cycle:	55		
Control Type:	Pretimed		
Maximum v/c Ratio:	0.53		
Intersection Signal Delay:	9.0	Intersection LOS:	A
Intersection Capacity Utilization	42.8%	ICU Level of Service	A
Analysis Period (min)	15		

Splits and Phases: 13: Nepean & O'Connor



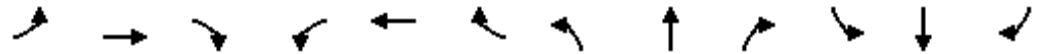

Lane Group	EBL	EBT	EBR	WBL	WBT	WBR	NBL	NBT	NBR	SBL	SBT	SBR
Lane Configurations					↑	↗		↖↖↖				
Ideal Flow (vphpl)	1750	1750	1750	1750	1750	1750	1750	1750	1750	1750	1750	1750
Storage Length (m)	0.0		0.0	0.0		15.0	0.0		0.0	0.0		0.0
Storage Lanes	0		0	0		1	0		0	0		0
Total Lost Time (s)	4.0	4.0	4.0	4.0	4.0	4.0	4.0	4.0	4.0	4.0	4.0	4.0
Turning Speed (k/h)	24		14	24		14	24		14	24		14
Lane Util. Factor	1.00	1.00	1.00	1.00	1.00	1.00	0.91	0.91	1.00	1.00	1.00	1.00
Ped Bike Factor						0.87		0.95				
Frt						0.850						
Flt Protected								0.983				
Satd. Flow (prot)	0	0	0	0	1697	1442	0	4553	0	0	0	0
Flt Permitted								0.983				
Satd. Flow (perm)	0	0	0	0	1697	1259	0	4341	0	0	0	0
Right Turn on Red			Yes			Yes	Yes		Yes			Yes
Satd. Flow (RTOR)						109		170				
Headway Factor	1.01	1.01	1.01	1.01	1.01	1.01	1.01	1.01	1.01	1.01	1.01	1.01
Link Speed (k/h)		50			50			50			50	
Link Distance (m)		182.2			96.8			83.3			76.7	
Travel Time (s)		13.1			7.0			6.0			5.5	
Volume (vph)	0	0	0	0	209	100	217	409	0	0	0	0
Confl. Peds. (#/hr)	54		59	59		54	112		267	267		112
Confl. Bikes (#/hr)						60						9
Peak Hour Factor	0.92	0.92	0.92	0.92	0.92	0.92	0.92	0.92	0.92	0.92	0.92	0.92
Adj. Flow (vph)	0	0	0	0	227	109	236	445	0	0	0	0
Lane Group Flow (vph)	0	0	0	0	227	109	0	681	0	0	0	0
Turn Type						Perm	Perm					
Protected Phases					8			2				
Permitted Phases						8	2					
Minimum Split (s)					19.0	19.0	30.0	30.0				
Total Split (s)	0.0	0.0	0.0	0.0	19.0	19.0	41.0	41.0	0.0	0.0	0.0	0.0
Total Split (%)	0.0%	0.0%	0.0%	0.0%	31.7%	31.7%	68.3%	68.3%	0.0%	0.0%	0.0%	0.0%
Maximum Green (s)					14.0	14.0	36.0	36.0				
Yellow Time (s)					3.3	3.3	3.3	3.3				
All-Red Time (s)					1.7	1.7	1.7	1.7				
Lead/Lag												
Lead-Lag Optimize?												
Walk Time (s)					7.0	7.0	19.0	19.0				
Flash Dont Walk (s)					7.0	7.0	6.0	6.0				
Pedestrian Calls (#/hr)					20	20	40	40				
Act Effct Green (s)					15.0	15.0		37.0				
Actuated g/C Ratio					0.25	0.25		0.62				
v/c Ratio					0.54	0.27		0.25				
Control Delay					25.0	6.6		3.6				
Queue Delay					0.0	0.0		0.0				
Total Delay					25.0	6.6		3.6				
LOS					C	A		A				
Approach Delay					19.0			3.6				
Approach LOS					B			A				

Intersection Summary

Area Type:	Other
Cycle Length:	60
Actuated Cycle Length:	60
Offset:	33 (55%), Referenced to phase 2:NBTL and 6:., Start of Green
Natural Cycle:	50
Control Type:	Pretimed
Maximum v/c Ratio:	0.54
Intersection Signal Delay:	8.7
Intersection LOS:	A
Intersection Capacity Utilization	39.4%
ICU Level of Service	A
Analysis Period (min)	15

Splits and Phases: 15: Gloucester & Metcalfe

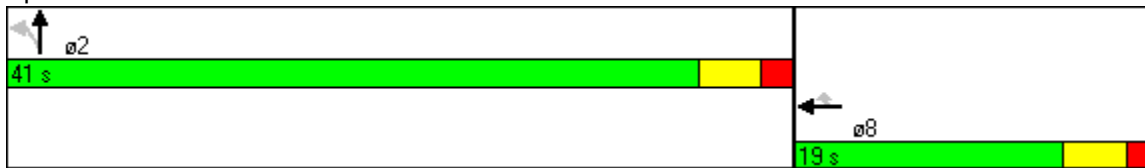





Lane Group	EBL	EBT	EBR	WBL	WBT	WBR	NBL	NBT	NBR	SBL	SBT	SBR
Lane Configurations				↙	↘						↑↑↑	
Ideal Flow (vphpl)	1750	1750	1750	1750	1750	1750	1750	1750	1750	1750	1750	1750
Storage Length (m)	0.0		0.0	15.0		0.0	0.0		0.0	0.0		0.0
Storage Lanes	0		0	1		0	0		0	0		0
Total Lost Time (s)	4.0	4.0	4.0	4.0	4.0	4.0	4.0	4.0	4.0	4.0	4.0	4.0
Turning Speed (k/h)	24		14	24		14	24		14	24		14
Lane Util. Factor	1.00	1.00	1.00	1.00	1.00	1.00	1.00	1.00	1.00	1.00	0.86	0.86
Ped Bike Factor				0.96							0.98	
Frt											0.984	
Flt Protected				0.950								
Satd. Flow (prot)	0	0	0	1612	1697	0	0	0	0	0	5634	0
Flt Permitted				0.950								
Satd. Flow (perm)	0	0	0	1540	1697	0	0	0	0	0	5634	0
Right Turn on Red			Yes	Yes		Yes			Yes			Yes
Satd. Flow (RTOR)				40							72	
Headway Factor	1.01	1.01	1.01	1.01	1.01	1.01	1.01	1.01	1.01	1.01	1.01	1.01
Link Speed (k/h)		50			50			50			50	
Link Distance (m)		108.3			182.2			82.4			78.3	
Travel Time (s)		7.8			13.1			5.9			5.6	
Volume (vph)	0	0	0	312	206	0	0	0	0	0	903	108
Confl. Peds. (#/hr)	198		37	37		198	105		138	138		105
Confl. Bikes (#/hr)			34			1						29
Peak Hour Factor	0.92	0.92	0.92	0.92	0.92	0.92	0.92	0.92	0.92	0.92	0.92	0.92
Adj. Flow (vph)	0	0	0	339	224	0	0	0	0	0	982	117
Lane Group Flow (vph)	0	0	0	339	224	0	0	0	0	0	1099	0
Turn Type				Perm								
Protected Phases					8						6	
Permitted Phases				8								
Minimum Split (s)				25.0	25.0						35.0	
Total Split (s)	0.0	0.0	0.0	25.0	25.0	0.0	0.0	0.0	0.0	0.0	35.0	0.0
Total Split (%)	0.0%	0.0%	0.0%	41.7%	41.7%	0.0%	0.0%	0.0%	0.0%	0.0%	58.3%	0.0%
Maximum Green (s)				19.7	19.7						29.9	
Yellow Time (s)				3.3	3.3						3.3	
All-Red Time (s)				2.0	2.0						1.8	
Lead/Lag												
Lead-Lag Optimize?												
Walk Time (s)				7.0	7.0						15.0	
Flash Dont Walk (s)				8.0	8.0						7.0	
Pedestrian Calls (#/hr)				20	20						40	
Act Effct Green (s)				21.0	21.0						31.0	
Actuated g/C Ratio				0.35	0.35						0.52	
v/c Ratio				0.60	0.38						0.37	
Control Delay				14.1	11.8						8.5	
Queue Delay				0.0	0.0						0.0	
Total Delay				14.1	11.8						8.5	
LOS				B	B						A	
Approach Delay					13.2						8.5	
Approach LOS					B						A	

Intersection Summary

Area Type:	Other		
Cycle Length:	60		
Actuated Cycle Length:	60		
Offset:	1 (2%), Referenced to phase 2: and 6:SBT, Start of Green		
Natural Cycle:	60		
Control Type:	Pretimed		
Maximum v/c Ratio:	0.60		
Intersection Signal Delay:	10.1	Intersection LOS:	B
Intersection Capacity Utilization	43.8%	ICU Level of Service	A
Analysis Period (min)	15		

Splits and Phases: 16: Gloucester & O'Connor





Movement	EBT	EBR	WBL	WBT	NBL	NBR
Lane Configurations	↻					↻
Sign Control	Free			Free	Stop	
Grade	0%			0%	0%	
Volume (veh/h)	331	34	0	0	0	48
Peak Hour Factor	0.92	0.92	0.92	0.92	0.92	0.92
Hourly flow rate (vph)	360	37	0	0	0	52
Pedestrians						
Lane Width (m)						
Walking Speed (m/s)						
Percent Blockage						
Right turn flare (veh)						
Median type					None	
Median storage (veh)						
Upstream signal (m)	99			83		
pX, platoon unblocked						
vC, conflicting volume			397		378	378
vC1, stage 1 conf vol						
vC2, stage 2 conf vol						
vCu, unblocked vol			397		378	378
tC, single (s)			4.1		6.4	6.2
tC, 2 stage (s)						
tF (s)			2.2		3.5	3.3
p0 queue free %			100		100	92
cM capacity (veh/h)			1162		624	668

Direction, Lane #	EB 1	NB 1
Volume Total	397	52
Volume Left	0	0
Volume Right	37	52
cSH	1700	668
Volume to Capacity	0.23	0.08
Queue Length 95th (m)	0.0	1.9
Control Delay (s)	0.0	10.8
Lane LOS		B
Approach Delay (s)	0.0	10.8
Approach LOS		B

Intersection Summary			
Average Delay		1.3	
Intersection Capacity Utilization	31.2%	ICU Level of Service	A
Analysis Period (min)		15	

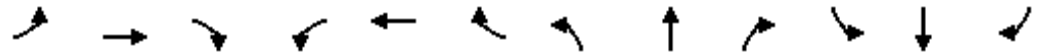

Movement	EBL	EBT	EBR	WBL	WBT	WBR	NBL	NBT	NBR	SBL	SBT	SBR
Lane Configurations	↙	↑						↑↑↑				
Sign Control		Stop			Stop			Free			Free	
Grade		0%			0%			0%			0%	
Volume (veh/h)	186	137	0	0	0	0	0	963	258	0	0	0
Peak Hour Factor	0.92	0.92	0.92	0.92	0.92	0.92	0.92	0.92	0.92	0.92	0.92	0.92
Hourly flow rate (vph)	202	149	0	0	0	0	0	1047	280	0	0	0
Pedestrians		330			225			40			40	
Lane Width (m)		3.5			0.0			3.5			0.0	
Walking Speed (m/s)		1.2			1.2			1.2			1.2	
Percent Blockage		27			0			3			0	
Right turn flare (veh)												
Median type		None			None							
Median storage veh												
Upstream signal (m)											83	
pX, platoon unblocked												
vC, conflicting volume	719	1882	370	1526	1742	754	330			1552		
vC1, stage 1 conf vol												
vC2, stage 2 conf vol												
vCu, unblocked vol	719	1882	370	1526	1742	754	330			1552		
tC, single (s)	7.5	6.5	6.9	7.5	6.5	6.9	4.1			4.1		
tC, 2 stage (s)												
tF (s)	3.5	4.0	3.3	3.5	4.0	3.3	2.2			2.2		
p0 queue free %	0	0	100	0	100	100	100			100		
cM capacity (veh/h)	184	51	445	0	63	352	898			423		
<b>Direction, Lane #</b>	<b>EB 1</b>	<b>EB 2</b>	<b>NB 1</b>	<b>NB 2</b>	<b>NB 3</b>							
Volume Total	202	149	419	419	490							
Volume Left	202	0	0	0	0							
Volume Right	0	0	0	0	280							
cSH	184	51	1700	1700	1700							
Volume to Capacity	1.10	2.90	0.25	0.25	0.29							
Queue Length 95th (m)	75.6	119.6	0.0	0.0	0.0							
Control Delay (s)	148.4	1024.1	0.0	0.0	0.0							
Lane LOS	F	F										
Approach Delay (s)	519.8		0.0									
Approach LOS	F											
<b>Intersection Summary</b>												
Average Delay			108.7									
Intersection Capacity Utilization			46.7%	ICU Level of Service	A							
Analysis Period (min)			15									



Movement	EBL	EBT	EBR	WBL	WBT	WBR	NBL	NBT	NBR	SBL	SBT	SBR
Lane Configurations		↑	↗								↑↑↑	
Sign Control		Stop			Stop			Free			Free	
Grade		0%			0%			0%			0%	
Volume (veh/h)	0	116	74	0	0	0	0	0	0	194	745	0
Peak Hour Factor	0.92	0.92	0.92	0.92	0.92	0.92	0.92	0.92	0.92	0.92	0.92	0.92
Hourly flow rate (vph)	0	126	80	0	0	0	0	0	0	211	810	0
Pedestrians		237			173			25			32	
Lane Width (m)		3.5			0.0			0.0			3.5	
Walking Speed (m/s)		1.2			1.2			1.2			1.2	
Percent Blockage		19			0			0			3	
Right turn flare (veh)			2									
Median type		None			None							
Median storage veh												
Upstream signal (m)											82	
pX, platoon unblocked												
vC, conflicting volume	1501	1642	464	925	1642	205	1047			173		
vC1, stage 1 conf vol												
vC2, stage 2 conf vol												
vCu, unblocked vol	1501	1642	464	925	1642	205	1047			173		
tC, single (s)	7.5	6.5	6.9	7.5	6.5	6.9	4.1			4.1		
tC, 2 stage (s)												
tF (s)	3.5	4.0	3.3	3.5	4.0	3.3	2.2			2.2		
p0 queue free %	100	0	82	0	100	100	100			85		
cM capacity (veh/h)	50	68	440	0	68	781	534			1401		

Direction, Lane #	EB 1	SB 1	SB 2	SB 3	SB 4
Volume Total	207	327	231	231	231
Volume Left	0	211	0	0	0
Volume Right	80	0	0	0	0
cSH	102	1401	1700	1700	1700
Volume to Capacity	2.02	0.15	0.14	0.14	0.14
Queue Length 95th (m)	132.7	4.0	0.0	0.0	0.0
Control Delay (s)	559.6	5.6	0.0	0.0	0.0
Lane LOS	F	A			
Approach Delay (s)	559.6	1.8			
Approach LOS	F				

Intersection Summary		
Average Delay		95.7
Intersection Capacity Utilization	35.4%	ICU Level of Service
Analysis Period (min)		15



Lane Group	EBL	EBT	EBR	WBL	WBT	WBR	NBL	NBT	NBR	SBL	SBT	SBR
Lane Configurations					↑	↗		↖↖↖				
Ideal Flow (vphpl)	1750	1750	1750	1750	1750	1750	1750	1750	1750	1750	1750	1750
Storage Length (m)	0.0		0.0	0.0		15.0	0.0		0.0	0.0		0.0
Storage Lanes	0		0	0		1	0		0	0		0
Total Lost Time (s)	4.0	4.0	4.0	4.0	4.0	4.0	4.0	4.0	4.0	4.0	4.0	4.0
Turning Speed (k/h)	24		14	24		14	24		14	24		14
Lane Util. Factor	1.00	1.00	1.00	1.00	1.00	1.00	0.91	0.91	1.00	1.00	1.00	1.00
Ped Bike Factor						0.87		0.95				
Frt						0.850						
Flt Protected								0.982				
Satd. Flow (prot)	0	0	0	0	1697	1442	0	4548	0	0	0	0
Flt Permitted								0.982				
Satd. Flow (perm)	0	0	0	0	1697	1259	0	4327	0	0	0	0
Right Turn on Red			Yes			Yes	Yes		Yes			Yes
Satd. Flow (RTOR)						68		241				
Headway Factor	1.01	1.01	1.01	1.01	1.01	1.01	1.01	1.01	1.01	1.01	1.01	1.01
Link Speed (k/h)		50			50			50			50	
Link Distance (m)		182.2			96.8			83.3			76.7	
Travel Time (s)		13.1			7.0			6.0			5.5	
Volume (vph)	0	0	0	0	150	63	313	551	0	0	0	0
Confl. Peds. (#/hr)	54		59	59		54	112		267	267		112
Confl. Bikes (#/hr)						60						9
Peak Hour Factor	0.92	0.92	0.92	0.92	0.92	0.92	0.92	0.92	0.92	0.92	0.92	0.92
Adj. Flow (vph)	0	0	0	0	163	68	340	599	0	0	0	0
Lane Group Flow (vph)	0	0	0	0	163	68	0	939	0	0	0	0
Turn Type						Perm	Perm					
Protected Phases					8			2				
Permitted Phases						8	2					
Minimum Split (s)					19.0	19.0	30.0	30.0				
Total Split (s)	0.0	0.0	0.0	0.0	19.0	19.0	41.0	41.0	0.0	0.0	0.0	0.0
Total Split (%)	0.0%	0.0%	0.0%	0.0%	31.7%	31.7%	68.3%	68.3%	0.0%	0.0%	0.0%	0.0%
Maximum Green (s)					14.0	14.0	36.0	36.0				
Yellow Time (s)					3.3	3.3	3.3	3.3				
All-Red Time (s)					1.7	1.7	1.7	1.7				
Lead/Lag												
Lead-Lag Optimize?												
Walk Time (s)					7.0	7.0	19.0	19.0				
Flash Dont Walk (s)					7.0	7.0	6.0	6.0				
Pedestrian Calls (#/hr)					20	20	40	40				
Act Effct Green (s)					15.0	15.0		37.0				
Actuated g/C Ratio					0.25	0.25		0.62				
v/c Ratio					0.38	0.19		0.34				
Control Delay					21.9	7.0		4.4				
Queue Delay					0.0	0.0		0.0				
Total Delay					21.9	7.0		4.4				
LOS					C	A		A				
Approach Delay					17.5			4.4				
Approach LOS					B			A				

Intersection Summary

Area Type:	Other		
Cycle Length:	60		
Actuated Cycle Length:	60		
Offset:	33 (55%), Referenced to phase 2:NBTL and 6:., Start of Green		
Natural Cycle:	50		
Control Type:	Pretimed		
Maximum v/c Ratio:	0.38		
Intersection Signal Delay:	7.0	Intersection LOS:	A
Intersection Capacity Utilization	39.2%	ICU Level of Service	A
Analysis Period (min)	15		

Splits and Phases: 15: Gloucester & Metcalfe

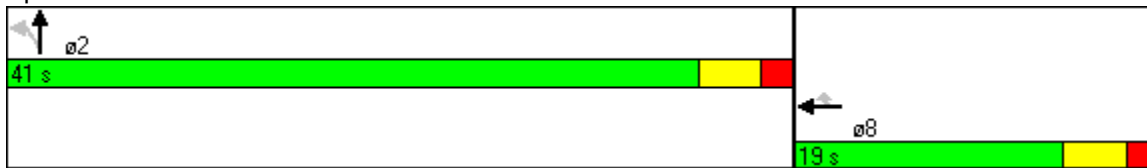

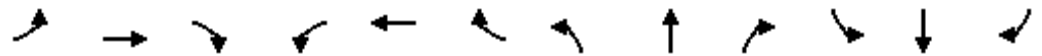

Lane Group	EBL	EBT	EBR	WBL	WBT	WBR	NBL	NBT	NBR	SBL	SBT	SBR
Lane Configurations				↙	↘						↑↑↑	
Ideal Flow (vphpl)	1750	1750	1750	1750	1750	1750	1750	1750	1750	1750	1750	1750
Storage Length (m)	0.0		0.0	15.0		0.0	0.0		0.0	0.0		0.0
Storage Lanes	0		0	1		0	0		0	0		0
Total Lost Time (s)	4.0	4.0	4.0	4.0	4.0	4.0	4.0	4.0	4.0	4.0	4.0	4.0
Turning Speed (k/h)	24		14	24		14	24		14	24		14
Lane Util. Factor	1.00	1.00	1.00	1.00	1.00	1.00	1.00	1.00	1.00	1.00	0.86	0.86
Ped Bike Factor				0.96							0.95	
Frt											0.962	
Flt Protected				0.950								
Satd. Flow (prot)	0	0	0	1612	1697	0	0	0	0	0	5361	0
Flt Permitted				0.950								
Satd. Flow (perm)	0	0	0	1540	1697	0	0	0	0	0	5361	0
Right Turn on Red			Yes	Yes		Yes			Yes			Yes
Satd. Flow (RTOR)				120							98	
Headway Factor	1.01	1.01	1.01	1.01	1.01	1.01	1.01	1.01	1.01	1.01	1.01	1.01
Link Speed (k/h)		50			50			50			50	
Link Distance (m)		108.3			182.2			82.4			78.3	
Travel Time (s)		7.8			13.1			5.9			5.6	
Volume (vph)	0	0	0	232	198	0	0	0	0	0	530	180
Confl. Peds. (#/hr)	198		37	37		198	105		138	138		105
Confl. Bikes (#/hr)			34			1						29
Peak Hour Factor	0.92	0.92	0.92	0.92	0.92	0.92	0.92	0.92	0.92	0.92	0.92	0.92
Adj. Flow (vph)	0	0	0	252	215	0	0	0	0	0	576	196
Lane Group Flow (vph)	0	0	0	252	215	0	0	0	0	0	772	0
Turn Type				Perm								
Protected Phases					8						6	
Permitted Phases				8								
Minimum Split (s)				25.0	25.0						35.0	
Total Split (s)	0.0	0.0	0.0	25.0	25.0	0.0	0.0	0.0	0.0	0.0	35.0	0.0
Total Split (%)	0.0%	0.0%	0.0%	41.7%	41.7%	0.0%	0.0%	0.0%	0.0%	0.0%	58.3%	0.0%
Maximum Green (s)				19.7	19.7						29.9	
Yellow Time (s)				3.3	3.3						3.3	
All-Red Time (s)				2.0	2.0						1.8	
Lead/Lag												
Lead-Lag Optimize?												
Walk Time (s)				7.0	7.0						15.0	
Flash Dont Walk (s)				8.0	8.0						7.0	
Pedestrian Calls (#/hr)				20	20						40	
Act Effct Green (s)				21.0	21.0						31.0	
Actuated g/C Ratio				0.35	0.35						0.52	
v/c Ratio				0.41	0.36						0.27	
Control Delay				6.9	13.0						7.3	
Queue Delay				0.0	0.0						0.0	
Total Delay				6.9	13.0						7.3	
LOS				A	B						A	
Approach Delay					9.7						7.3	
Approach LOS					A						A	



Intersection Summary

Area Type:	Other		
Cycle Length:	60		
Actuated Cycle Length:	60		
Offset:	1 (2%), Referenced to phase 2: and 6:SBT, Start of Green		
Natural Cycle:	60		
Control Type:	Pretimed		
Maximum v/c Ratio:	0.41		
Intersection Signal Delay:	8.2	Intersection LOS:	A
Intersection Capacity Utilization	39.2%	ICU Level of Service	A
Analysis Period (min)	15		

Splits and Phases: 16: Gloucester & O'Connor





Movement	EBT	EBR	WBL	WBT	NBL	NBR
Lane Configurations	↻					↻
Sign Control	Free			Free	Stop	
Grade	0%			0%	0%	
Volume (veh/h)	238	11	0	0	0	22
Peak Hour Factor	0.92	0.92	0.92	0.92	0.92	0.92
Hourly flow rate (vph)	259	12	0	0	0	24
Pedestrians						
Lane Width (m)						
Walking Speed (m/s)						
Percent Blockage						
Right turn flare (veh)						
Median type	None					
Median storage (veh)						
Upstream signal (m)						
pX, platoon unblocked						
vC, conflicting volume			271		265	265
vC1, stage 1 conf vol						
vC2, stage 2 conf vol						
vCu, unblocked vol			271		265	265
tC, single (s)			4.1		6.4	6.2
tC, 2 stage (s)						
tF (s)			2.2		3.5	3.3
p0 queue free %			100		100	97
cM capacity (veh/h)			1293		724	774

Direction, Lane #	EB 1	NB 1
Volume Total	271	24
Volume Left	0	0
Volume Right	12	24
cSH	1700	774
Volume to Capacity	0.16	0.03
Queue Length 95th (m)	0.0	0.7
Control Delay (s)	0.0	9.8
Lane LOS		A
Approach Delay (s)	0.0	9.8
Approach LOS		A

Intersection Summary			
Average Delay		0.8	
Intersection Capacity Utilization	24.3%	ICU Level of Service	A
Analysis Period (min)		15	



Movement	EBL	EBT	EBR	WBL	WBT	WBR	NBL	NBT	NBR	SBL	SBT	SBR
Lane Configurations	↘	↑						↑↑↑				
Sign Control		Stop			Stop			Free			Free	
Grade		0%			0%			0%			0%	
Volume (veh/h)	191	159	0	0	0	0	0	526	242	0	0	0
Peak Hour Factor	0.92	0.92	0.92	0.92	0.92	0.92	0.92	0.92	0.92	0.92	0.92	0.92
Hourly flow rate (vph)	208	173	0	0	0	0	0	572	263	0	0	0
Pedestrians		232			146			40			40	
Lane Width (m)		3.5			0.0			3.5			0.0	
Walking Speed (m/s)		1.2			1.2			1.2			1.2	
Percent Blockage		19			0			3			0	
Right turn flare (veh)												
Median type		None			None							
Median storage veh												
Upstream signal (m)											83	
pX, platoon unblocked												
vC, conflicting volume	463	1213	272	976	1081	508	232			981		
vC1, stage 1 conf vol												
vC2, stage 2 conf vol												
vCu, unblocked vol	463	1213	272	976	1081	508	232			981		
tC, single (s)	7.5	6.5	6.9	7.5	6.5	6.9	4.1			4.1		
tC, 2 stage (s)												
tF (s)	3.5	4.0	3.3	3.5	4.0	3.3	2.2			2.2		
p0 queue free %	38	0	100	0	100	100	100			100		
cM capacity (veh/h)	335	147	570	0	176	510	1082			700		
<b>Direction, Lane #</b>	<b>EB 1</b>	<b>EB 2</b>	<b>NB 1</b>	<b>NB 2</b>	<b>NB 3</b>							
Volume Total	208	173	229	229	377							
Volume Left	208	0	0	0	0							
Volume Right	0	0	0	0	263							
cSH	335	147	1700	1700	1700							
Volume to Capacity	0.62	1.18	0.13	0.13	0.22							
Queue Length 95th (m)	29.8	74.9	0.0	0.0	0.0							
Control Delay (s)	31.7	190.8	0.0	0.0	0.0							
Lane LOS	D	F										
Approach Delay (s)	104.0		0.0									
Approach LOS	F											
<b>Intersection Summary</b>												
Average Delay			32.6									
Intersection Capacity Utilization			38.0%	ICU Level of Service	A							
Analysis Period (min)			15									

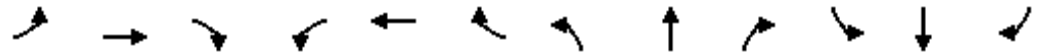

Movement	EBL	EBT	EBR	WBL	WBT	WBR	NBL	NBT	NBR	SBL	SBT	SBR
Lane Configurations		↑	↗								↑↑↑	
Sign Control		Stop			Stop			Free			Free	
Grade		0%			0%			0%			0%	
Volume (veh/h)	0	137	148	0	0	0	0	0	0	231	1220	0
Peak Hour Factor	0.92	0.92	0.92	0.92	0.92	0.92	0.92	0.92	0.92	0.92	0.92	0.92
Hourly flow rate (vph)	0	149	161	0	0	0	0	0	0	251	1326	0
Pedestrians		186			108			19			13	
Lane Width (m)		3.5			0.0			0.0			3.5	
Walking Speed (m/s)		1.2			1.2			1.2			1.2	
Percent Blockage		15			0			0			1	
Right turn flare (veh)			2									
Median type		None			None							
Median storage veh												
Upstream signal (m)											82	
pX, platoon unblocked	0.93	0.93	0.93	0.93	0.93		0.93					
vC, conflicting volume	2027	2122	537	1116	2122	121	1512			108		
vC1, stage 1 conf vol												
vC2, stage 2 conf vol												
vCu, unblocked vol	1880	1982	277	900	1982	121	1326			108		
tC, single (s)	7.5	6.5	6.9	7.5	6.5	6.9	4.1			4.1		
tC, 2 stage (s)												
tF (s)	3.5	4.0	3.3	3.5	4.0	3.3	2.2			2.2		
p0 queue free %	100	0	72	0	100	100	100			83		
cM capacity (veh/h)	26	40	569	0	40	898	408			1480		
<b>Direction, Lane #</b>	<b>EB 1</b>	<b>SB 1</b>	<b>SB 2</b>	<b>SB 3</b>	<b>SB 4</b>							
Volume Total	310	441	379	379	379							
Volume Left	0	251	0	0	0							
Volume Right	161	0	0	0	0							
cSH	77	1480	1700	1700	1700							
Volume to Capacity	4.01	0.17	0.22	0.22	0.22							
Queue Length 95th (m)	Err	4.6	0.0	0.0	0.0							
Control Delay (s)	Err	5.2	0.0	0.0	0.0							
Lane LOS	F	A										
Approach Delay (s)	Err	1.4										
Approach LOS	F											
<b>Intersection Summary</b>												
Average Delay			1642.7									
Intersection Capacity Utilization			42.2%		ICU Level of Service					A		
Analysis Period (min)			15									



Lane Group	EBL	EBT	EBR	WBL	WBT	WBR	NBL	NBT	NBR	SBL	SBT	SBR
Lane Configurations					↑	↗		↖↖↖				
Ideal Flow (vphpl)	1750	1750	1750	1750	1750	1750	1750	1750	1750	1750	1750	1750
Storage Length (m)	0.0		0.0	0.0		15.0	0.0		0.0	0.0		0.0
Storage Lanes	0		0	0		1	0		0	0		0
Total Lost Time (s)	4.0	4.0	4.0	4.0	4.0	4.0	4.0	4.0	4.0	4.0	4.0	4.0
Turning Speed (k/h)	24		14	24		14	24		14	24		14
Lane Util. Factor	1.00	1.00	1.00	1.00	1.00	1.00	0.91	0.91	1.00	1.00	1.00	1.00
Ped Bike Factor						0.87		0.95				
Frt						0.850						
Flt Protected								0.983				
Satd. Flow (prot)	0	0	0	0	1697	1442	0	4553	0	0	0	0
Flt Permitted								0.983				
Satd. Flow (perm)	0	0	0	0	1697	1259	0	4343	0	0	0	0
Right Turn on Red			Yes			Yes	Yes		Yes			Yes
Satd. Flow (RTOR)						114		161				
Headway Factor	1.01	1.01	1.01	1.01	1.01	1.01	1.01	1.01	1.01	1.01	1.01	1.01
Link Speed (k/h)		50			50			50			50	
Link Distance (m)		182.2			96.8			83.3			76.7	
Travel Time (s)		13.1			7.0			6.0			5.5	
Volume (vph)	0	0	0	0	218	105	224	429	0	0	0	0
Confl. Peds. (#/hr)	54		59	59		54	112		267	267		112
Confl. Bikes (#/hr)						60						9
Peak Hour Factor	0.92	0.92	0.92	0.92	0.92	0.92	0.92	0.92	0.92	0.92	0.92	0.92
Adj. Flow (vph)	0	0	0	0	237	114	243	466	0	0	0	0
Lane Group Flow (vph)	0	0	0	0	237	114	0	709	0	0	0	0
Turn Type						Perm	Perm					
Protected Phases					8			2				
Permitted Phases						8	2					
Minimum Split (s)					19.0	19.0	30.0	30.0				
Total Split (s)	0.0	0.0	0.0	0.0	19.0	19.0	41.0	41.0	0.0	0.0	0.0	0.0
Total Split (%)	0.0%	0.0%	0.0%	0.0%	31.7%	31.7%	68.3%	68.3%	0.0%	0.0%	0.0%	0.0%
Maximum Green (s)					14.0	14.0	36.0	36.0				
Yellow Time (s)					3.3	3.3	3.3	3.3				
All-Red Time (s)					1.7	1.7	1.7	1.7				
Lead/Lag												
Lead-Lag Optimize?												
Walk Time (s)					7.0	7.0	19.0	19.0				
Flash Dont Walk (s)					7.0	7.0	6.0	6.0				
Pedestrian Calls (#/hr)					20	20	40	40				
Act Effct Green (s)					15.0	15.0		37.0				
Actuated g/C Ratio					0.25	0.25		0.62				
v/c Ratio					0.56	0.28		0.26				
Control Delay					25.6	6.6		4.2				
Queue Delay					0.0	0.0		0.0				
Total Delay					25.6	6.6		4.2				
LOS					C	A		A				
Approach Delay					19.4			4.2				
Approach LOS					B			A				

Intersection Summary

Area Type:	Other		
Cycle Length:	60		
Actuated Cycle Length:	60		
Offset:	33 (55%), Referenced to phase 2:NBTL and 6:., Start of Green		
Natural Cycle:	50		
Control Type:	Pretimed		
Maximum v/c Ratio:	0.56		
Intersection Signal Delay:	9.2	Intersection LOS:	A
Intersection Capacity Utilization	40.0%	ICU Level of Service	A
Analysis Period (min)	15		

Splits and Phases: 15: Gloucester & Metcalfe

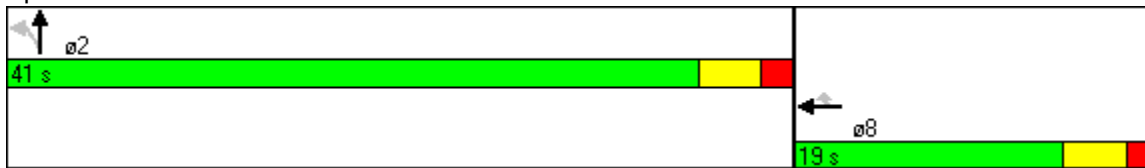



Lane Group	EBL	EBT	EBR	WBL	WBT	WBR	NBL	NBT	NBR	SBL	SBT	SBR
Lane Configurations				↖	↗						↑↑↑	
Ideal Flow (vphpl)	1750	1750	1750	1750	1750	1750	1750	1750	1750	1750	1750	1750
Storage Length (m)	0.0		0.0	15.0		0.0	0.0		0.0	0.0		0.0
Storage Lanes	0		0	1		0	0		0	0		0
Total Lost Time (s)	4.0	4.0	4.0	4.0	4.0	4.0	4.0	4.0	4.0	4.0	4.0	4.0
Turning Speed (k/h)	24		14	24		14	24		14	24		14
Lane Util. Factor	1.00	1.00	1.00	1.00	1.00	1.00	1.00	1.00	1.00	1.00	0.86	0.86
Ped Bike Factor				0.96							0.98	
Frt											0.984	
Flt Protected				0.950								
Satd. Flow (prot)	0	0	0	1612	1697	0	0	0	0	0	5633	0
Flt Permitted				0.950								
Satd. Flow (perm)	0	0	0	1540	1697	0	0	0	0	0	5633	0
Right Turn on Red			Yes	Yes		Yes			Yes			Yes
Satd. Flow (RTOR)				35							73	
Headway Factor	1.01	1.01	1.01	1.01	1.01	1.01	1.01	1.01	1.01	1.01	1.01	1.01
Link Speed (k/h)		50			50			50			50	
Link Distance (m)		108.3			182.2			82.4			78.3	
Travel Time (s)		7.8			13.1			5.9			5.6	
Volume (vph)	0	0	0	324	216	0	0	0	0	0	947	114
Confl. Peds. (#/hr)	198		37	37		198	105		138	138		105
Confl. Bikes (#/hr)			34			1						29
Peak Hour Factor	0.92	0.92	0.92	0.92	0.92	0.92	0.92	0.92	0.92	0.92	0.92	0.92
Adj. Flow (vph)	0	0	0	352	235	0	0	0	0	0	1029	124
Lane Group Flow (vph)	0	0	0	352	235	0	0	0	0	0	1153	0
Turn Type				Perm								
Protected Phases					8						6	
Permitted Phases				8								
Minimum Split (s)				25.0	25.0						35.0	
Total Split (s)	0.0	0.0	0.0	25.0	25.0	0.0	0.0	0.0	0.0	0.0	35.0	0.0
Total Split (%)	0.0%	0.0%	0.0%	41.7%	41.7%	0.0%	0.0%	0.0%	0.0%	0.0%	58.3%	0.0%
Maximum Green (s)				19.7	19.7						29.9	
Yellow Time (s)				3.3	3.3						3.3	
All-Red Time (s)				2.0	2.0						1.8	
Lead/Lag												
Lead-Lag Optimize?												
Walk Time (s)				7.0	7.0						15.0	
Flash Dont Walk (s)				8.0	8.0						7.0	
Pedestrian Calls (#/hr)				20	20						40	
Act Effct Green (s)				21.0	21.0						31.0	
Actuated g/C Ratio				0.35	0.35						0.52	
v/c Ratio				0.63	0.40						0.39	
Control Delay				16.3	13.2						8.6	
Queue Delay				0.0	0.0						0.0	
Total Delay				16.3	13.2						8.6	
LOS				B	B						A	
Approach Delay					15.1						8.6	
Approach LOS					B						A	

Intersection Summary

Area Type:	Other		
Cycle Length:	60		
Actuated Cycle Length:	60		
Offset:	1 (2%), Referenced to phase 2: and 6:SBT, Start of Green		
Natural Cycle:	60		
Control Type:	Pretimed		
Maximum v/c Ratio:	0.63		
Intersection Signal Delay:	10.8	Intersection LOS:	B
Intersection Capacity Utilization	44.5%	ICU Level of Service	A
Analysis Period (min)	15		

Splits and Phases: 16: Gloucester & O'Connor





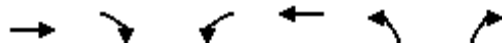

Movement	EBT	EBR	WBL	WBT	NBL	NBR
Lane Configurations	↶					↷
Sign Control	Free			Free	Stop	
Grade	0%			0%	0%	
Volume (veh/h)	343	34	0	0	0	48
Peak Hour Factor	0.92	0.92	0.92	0.92	0.92	0.92
Hourly flow rate (vph)	373	37	0	0	0	52
Pedestrians						
Lane Width (m)						
Walking Speed (m/s)						
Percent Blockage						
Right turn flare (veh)						
Median type					None	
Median storage (veh)						
Upstream signal (m)						
pX, platoon unblocked						
vC, conflicting volume			410		391	391
vC1, stage 1 conf vol						
vC2, stage 2 conf vol						
vCu, unblocked vol			410		391	391
tC, single (s)			4.1		6.4	6.2
tC, 2 stage (s)						
tF (s)			2.2		3.5	3.3
p0 queue free %			100		100	92
cM capacity (veh/h)			1149		613	657

Direction, Lane #	EB 1	NB 1
Volume Total	410	52
Volume Left	0	0
Volume Right	37	52
cSH	1700	657
Volume to Capacity	0.24	0.08
Queue Length 95th (m)	0.0	2.0
Control Delay (s)	0.0	10.9
Lane LOS		B
Approach Delay (s)	0.0	10.9
Approach LOS		B

Intersection Summary			
Average Delay		1.2	
Intersection Capacity Utilization	31.8%	ICU Level of Service	A
Analysis Period (min)		15	



Lane Group	EBL	EBT	EBR	WBL	WBT	WBR	NBL	NBT	NBR	SBL	SBT	SBR
Lane Configurations												
Ideal Flow (vphpl)	1750	1750	1750	1750	1750	1750	1750	1750	1750	1750	1750	1750
Storage Length (m)	15.0		0.0	0.0		0.0	0.0		0.0	0.0		0.0
Storage Lanes	1		0	0		0	0		0	0		0
Total Lost Time (s)	4.0	4.0	4.0	4.0	4.0	4.0	4.0	4.0	4.0	4.0	4.0	4.0
Turning Speed (k/h)	24		14	24		14	24		14	24		14
Lane Util. Factor	1.00	1.00	1.00	1.00	1.00	1.00	1.00	0.91	0.91	1.00	1.00	1.00
Ped Bike Factor	0.95							0.94				
Frt								0.968				
Flt Protected	0.950											
Satd. Flow (prot)	1612	1697	0	0	0	0	0	4205	0	0	0	0
Flt Permitted	0.950											
Satd. Flow (perm)	1529	1697	0	0	0	0	0	4205	0	0	0	0
Right Turn on Red	Yes		Yes			Yes			Yes			Yes
Satd. Flow (RTOR)	13							172				
Headway Factor	1.01	1.01	1.01	1.01	1.01	1.01	1.01	1.01	1.01	1.01	1.01	1.01
Link Speed (k/h)		30			30			50			50	
Link Distance (m)		82.2			94.2			73.5			83.3	
Travel Time (s)		9.9			11.3			5.3			6.0	
Volume (vph)	186	137	0	0	0	0	0	963	258	0	0	0
Confl. Peds. (#/hr)	40		40	40		40	330		225	225		330
Confl. Bikes (#/hr)						78			19			
Peak Hour Factor	0.92	0.92	0.92	0.92	0.92	0.92	0.92	0.92	0.92	0.92	0.92	0.92
Adj. Flow (vph)	202	149	0	0	0	0	0	1047	280	0	0	0
Lane Group Flow (vph)	202	149	0	0	0	0	0	1327	0	0	0	0
Turn Type	Perm											
Protected Phases		4						2				
Permitted Phases	4											
Minimum Split (s)	23.0	23.0						35.0				
Total Split (s)	24.0	24.0	0.0	0.0	0.0	0.0	0.0	36.0	0.0	0.0	0.0	0.0
Total Split (%)	40.0%	40.0%	0.0%	0.0%	0.0%	0.0%	0.0%	60.0%	0.0%	0.0%	0.0%	0.0%
Maximum Green (s)	19.0	19.0						31.0				
Yellow Time (s)	3.3	3.3						3.3				
All-Red Time (s)	1.7	1.7						1.7				
Lead/Lag												
Lead-Lag Optimize?												
Walk Time (s)	7.0	7.0						19.0				
Flash Dont Walk (s)	7.0	7.0						6.0				
Pedestrian Calls (#/hr)	0	0						0				
Act Effct Green (s)	20.0	20.0						32.0				
Actuated g/C Ratio	0.33	0.33						0.53				
v/c Ratio	0.39	0.26						0.57				
Control Delay	18.6	17.6						9.2				
Queue Delay	0.0	0.0						0.0				
Total Delay	18.6	17.6						9.2				
LOS	B	B						A				
Approach Delay		18.2						9.2				
Approach LOS		B						A				

Intersection Summary

Area Type:	Other		
Cycle Length:	60		
Actuated Cycle Length:	60		
Offset:	26 (43%), Referenced to phase 2:NBT and 6:, Start of Green		
Natural Cycle:	60		
Control Type:	Pretimed		
Maximum v/c Ratio:	0.57		
Intersection Signal Delay:	11.1	Intersection LOS:	B
Intersection Capacity Utilization	46.5%	ICU Level of Service	A
Analysis Period (min)	15		

Splits and Phases: 1: Nepean & Metcalfe

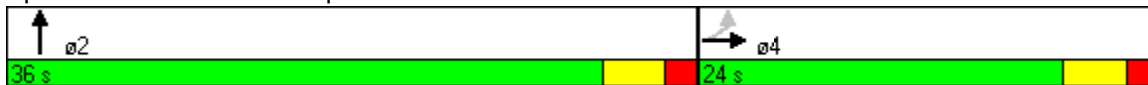



Lane Group	EBL	EBT	EBR	WBL	WBT	WBR	NBL	NBT	NBR	SBL	SBT	SBR
Lane Configurations		↑	↗								↑↑↑	
Ideal Flow (vphpl)	1750	1750	1750	1750	1750	1750	1750	1750	1750	1750	1750	1750
Storage Length (m)	0.0		15.0	0.0		0.0	0.0		0.0	0.0		0.0
Storage Lanes	0		1	0		0	0		0	0		0
Total Lost Time (s)	4.0	4.0	4.0	4.0	4.0	4.0	4.0	4.0	4.0	4.0	4.0	4.0
Turning Speed (k/h)	24		14	24		14	24		14	24		14
Lane Util. Factor	1.00	1.00	1.00	1.00	1.00	1.00	1.00	1.00	1.00	0.86	0.86	1.00
Ped Bike Factor			0.95								0.95	
Frt			0.850									
Flt Protected											0.990	
Satd. Flow (prot)	0	1697	1442	0	0	0	0	0	0	0	5778	0
Flt Permitted											0.990	
Satd. Flow (perm)	0	1697	1372	0	0	0	0	0	0	0	5496	0
Right Turn on Red			Yes			Yes			Yes	Yes		Yes
Satd. Flow (RTOR)			32								156	
Headway Factor	1.01	1.01	1.01	1.01	1.01	1.01	1.01	1.01	1.01	1.01	1.01	1.01
Link Speed (k/h)		30			30			50			50	
Link Distance (m)		109.5			95.0			73.8			82.4	
Travel Time (s)		13.1			11.4			5.3			5.9	
Volume (vph)	0	116	74	0	0	0	0	0	0	194	745	0
Confl. Peds. (#/hr)	32		25	25		32	237		173	173		237
Confl. Bikes (#/hr)			12			1			13			
Peak Hour Factor	0.92	0.92	0.92	0.92	0.92	0.92	0.92	0.92	0.92	0.92	0.92	0.92
Adj. Flow (vph)	0	126	80	0	0	0	0	0	0	211	810	0
Lane Group Flow (vph)	0	126	80	0	0	0	0	0	0	0	1021	0
Turn Type			Perm								Perm	
Protected Phases		4										6
Permitted Phases			4								6	
Minimum Split (s)		23.3	23.3							31.1	31.1	
Total Split (s)	0.0	26.0	26.0	0.0	0.0	0.0	0.0	0.0	0.0	34.0	34.0	0.0
Total Split (%)	0.0%	43.3%	43.3%	0.0%	0.0%	0.0%	0.0%	0.0%	0.0%	56.7%	56.7%	0.0%
Maximum Green (s)		20.7	20.7							28.9	28.9	
Yellow Time (s)		3.3	3.3							3.3	3.3	
All-Red Time (s)		2.0	2.0							1.8	1.8	
Lead/Lag												
Lead-Lag Optimize?												
Walk Time (s)		7.0	7.0							15.0	15.0	
Flash Dont Walk (s)		8.0	8.0							7.0	7.0	
Pedestrian Calls (#/hr)		0	0							0	0	
Act Effct Green (s)		22.0	22.0								30.0	
Actuated g/C Ratio		0.37	0.37								0.50	
v/c Ratio		0.20	0.15								0.36	
Control Delay		14.1	9.6								5.8	
Queue Delay		0.0	0.0								0.0	
Total Delay		14.1	9.6								5.8	
LOS		B	A								A	
Approach Delay		12.4									5.8	
Approach LOS		B									A	

Intersection Summary

Area Type:	Other
Cycle Length:	60
Actuated Cycle Length:	60
Offset:	7 (12%), Referenced to phase 2: and 6:SBTL, Start of Green
Natural Cycle:	55
Control Type:	Pretimed
Maximum v/c Ratio:	0.36
Intersection Signal Delay:	6.9
Intersection LOS:	A
Intersection Capacity Utilization	37.5%
ICU Level of Service	A
Analysis Period (min)	15

Splits and Phases: 13: Nepean & O'Connor





Lane Group	EBL	EBT	EBR	WBL	WBT	WBR	NBL	NBT	NBR	SBL	SBT	SBR
Lane Configurations					↑	↗		↖↖↖				
Ideal Flow (vphpl)	1750	1750	1750	1750	1750	1750	1750	1750	1750	1750	1750	1750
Storage Length (m)	0.0		0.0	0.0		15.0	0.0		0.0	0.0		0.0
Storage Lanes	0		0	0		1	0		0	0		0
Total Lost Time (s)	4.0	4.0	4.0	4.0	4.0	4.0	4.0	4.0	4.0	4.0	4.0	4.0
Turning Speed (k/h)	24		14	24		14	24		14	24		14
Lane Util. Factor	1.00	1.00	1.00	1.00	1.00	1.00	0.91	0.91	1.00	1.00	1.00	1.00
Ped Bike Factor						0.87		0.95				
Frt						0.850						
Flt Protected								0.982				
Satd. Flow (prot)	0	0	0	0	1697	1442	0	4548	0	0	0	0
Flt Permitted								0.982				
Satd. Flow (perm)	0	0	0	0	1697	1259	0	4327	0	0	0	0
Right Turn on Red			Yes			Yes	Yes		Yes			Yes
Satd. Flow (RTOR)						65		241				
Headway Factor	1.01	1.01	1.01	1.01	1.01	1.01	1.01	1.01	1.01	1.01	1.01	1.01
Link Speed (k/h)		50			50			50			50	
Link Distance (m)		182.2			96.8			83.3			76.7	
Travel Time (s)		13.1			7.0			6.0			5.5	
Volume (vph)	0	0	0	0	150	60	313	551	0	0	0	0
Confl. Peds. (#/hr)	54		59	59		54	112		267	267		112
Confl. Bikes (#/hr)						60						9
Peak Hour Factor	0.92	0.92	0.92	0.92	0.92	0.92	0.92	0.92	0.92	0.92	0.92	0.92
Adj. Flow (vph)	0	0	0	0	163	65	340	599	0	0	0	0
Lane Group Flow (vph)	0	0	0	0	163	65	0	939	0	0	0	0
Turn Type						Perm	Perm					
Protected Phases					8			2				
Permitted Phases						8	2					
Minimum Split (s)					19.0	19.0	30.0	30.0				
Total Split (s)	0.0	0.0	0.0	0.0	19.0	19.0	41.0	41.0	0.0	0.0	0.0	0.0
Total Split (%)	0.0%	0.0%	0.0%	0.0%	31.7%	31.7%	68.3%	68.3%	0.0%	0.0%	0.0%	0.0%
Maximum Green (s)					14.0	14.0	36.0	36.0				
Yellow Time (s)					3.3	3.3	3.3	3.3				
All-Red Time (s)					1.7	1.7	1.7	1.7				
Lead/Lag												
Lead-Lag Optimize?												
Walk Time (s)					7.0	7.0	19.0	19.0				
Flash Dont Walk (s)					7.0	7.0	6.0	6.0				
Pedestrian Calls (#/hr)					20	20	40	40				
Act Effct Green (s)					15.0	15.0		37.0				
Actuated g/C Ratio					0.25	0.25		0.62				
v/c Ratio					0.38	0.18		0.34				
Control Delay					21.9	7.0		1.8				
Queue Delay					0.0	0.0		0.2				
Total Delay					21.9	7.0		2.0				
LOS					C	A		A				
Approach Delay					17.7			2.0				
Approach LOS					B			A				

Intersection Summary

Area Type:	Other
Cycle Length:	60
Actuated Cycle Length:	60
Offset:	33 (55%), Referenced to phase 2:NBTL and 6:., Start of Green
Natural Cycle:	50
Control Type:	Pretimed
Maximum v/c Ratio:	0.38
Intersection Signal Delay:	5.1
Intersection LOS:	A
Intersection Capacity Utilization	39.2%
ICU Level of Service	A
Analysis Period (min)	15

Splits and Phases: 15: Gloucester & Metcalfe

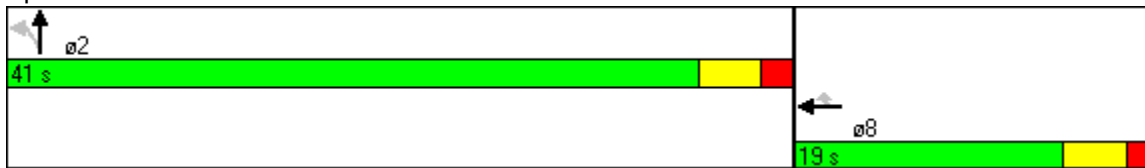



Lane Group	EBL	EBT	EBR	WBL	WBT	WBR	NBL	NBT	NBR	SBL	SBT	SBR
Lane Configurations				↙	↗						↑↑↑	
Ideal Flow (vphpl)	1750	1750	1750	1750	1750	1750	1750	1750	1750	1750	1750	1750
Storage Length (m)	0.0		0.0	15.0		0.0	0.0		0.0	0.0		0.0
Storage Lanes	0		0	1		0	0		0	0		0
Total Lost Time (s)	4.0	4.0	4.0	4.0	4.0	4.0	4.0	4.0	4.0	4.0	4.0	4.0
Turning Speed (k/h)	24		14	24		14	24		14	24		14
Lane Util. Factor	1.00	1.00	1.00	1.00	1.00	1.00	1.00	1.00	1.00	1.00	0.86	0.86
Ped Bike Factor				0.96							0.95	
Frt											0.962	
Flt Protected				0.950								
Satd. Flow (prot)	0	0	0	1612	1697	0	0	0	0	0	5361	0
Flt Permitted				0.950								
Satd. Flow (perm)	0	0	0	1540	1697	0	0	0	0	0	5361	0
Right Turn on Red			Yes	Yes		Yes			Yes			Yes
Satd. Flow (RTOR)				120							98	
Headway Factor	1.01	1.01	1.01	1.01	1.01	1.01	1.01	1.01	1.01	1.01	1.01	1.01
Link Speed (k/h)		50			50			50			50	
Link Distance (m)		108.3			182.2			82.4			78.3	
Travel Time (s)		7.8			13.1			5.9			5.6	
Volume (vph)	0	0	0	232	198	0	0	0	0	0	530	180
Confl. Peds. (#/hr)	198		37	37		198	105		138	138		105
Confl. Bikes (#/hr)			34			1						29
Peak Hour Factor	0.92	0.92	0.92	0.92	0.92	0.92	0.92	0.92	0.92	0.92	0.92	0.92
Adj. Flow (vph)	0	0	0	252	215	0	0	0	0	0	576	196
Lane Group Flow (vph)	0	0	0	252	215	0	0	0	0	0	772	0
Turn Type				Perm								
Protected Phases					8						6	
Permitted Phases				8								
Minimum Split (s)				25.0	25.0						35.0	
Total Split (s)	0.0	0.0	0.0	25.0	25.0	0.0	0.0	0.0	0.0	0.0	35.0	0.0
Total Split (%)	0.0%	0.0%	0.0%	41.7%	41.7%	0.0%	0.0%	0.0%	0.0%	0.0%	58.3%	0.0%
Maximum Green (s)				19.7	19.7						29.9	
Yellow Time (s)				3.3	3.3						3.3	
All-Red Time (s)				2.0	2.0						1.8	
Lead/Lag												
Lead-Lag Optimize?												
Walk Time (s)				7.0	7.0						15.0	
Flash Dont Walk (s)				8.0	8.0						7.0	
Pedestrian Calls (#/hr)				20	20						40	
Act Effct Green (s)				21.0	21.0						31.0	
Actuated g/C Ratio				0.35	0.35						0.52	
v/c Ratio				0.41	0.36						0.27	
Control Delay				6.5	12.3						7.3	
Queue Delay				0.0	0.0						0.0	
Total Delay				6.5	12.3						7.3	
LOS				A	B						A	
Approach Delay					9.2						7.3	
Approach LOS					A						A	



Intersection Summary

Area Type:	Other		
Cycle Length:	60		
Actuated Cycle Length:	60		
Offset:	1 (2%), Referenced to phase 2: and 6:SBT, Start of Green		
Natural Cycle:	60		
Control Type:	Pretimed		
Maximum v/c Ratio:	0.41		
Intersection Signal Delay:	8.0	Intersection LOS:	A
Intersection Capacity Utilization	39.2%	ICU Level of Service	A
Analysis Period (min)	15		

Splits and Phases: 16: Gloucester & O'Connor



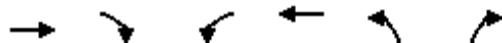

Movement	EBT	EBR	WBL	WBT	NBL	NBR
Lane Configurations	↶					↷
Sign Control	Free			Free	Stop	
Grade	0%			0%	0%	
Volume (veh/h)	238	11	0	0	0	22
Peak Hour Factor	0.92	0.92	0.92	0.92	0.92	0.92
Hourly flow rate (vph)	259	12	0	0	0	24
Pedestrians						
Lane Width (m)						
Walking Speed (m/s)						
Percent Blockage						
Right turn flare (veh)						
Median type					None	
Median storage (veh)						
Upstream signal (m)	100			82		
pX, platoon unblocked						
vC, conflicting volume			271		265	265
vC1, stage 1 conf vol						
vC2, stage 2 conf vol						
vCu, unblocked vol			271		265	265
tC, single (s)			4.1		6.4	6.2
tC, 2 stage (s)						
tF (s)			2.2		3.5	3.3
p0 queue free %			100		100	97
cM capacity (veh/h)			1293		724	774

Direction, Lane #	EB 1	NB 1
Volume Total	271	24
Volume Left	0	0
Volume Right	12	24
cSH	1700	774
Volume to Capacity	0.16	0.03
Queue Length 95th (m)	0.0	0.7
Control Delay (s)	0.0	9.8
Lane LOS		A
Approach Delay (s)	0.0	9.8
Approach LOS		A

Intersection Summary			
Average Delay		0.8	
Intersection Capacity Utilization	24.3%	ICU Level of Service	A
Analysis Period (min)		15	



Lane Group	EBL	EBT	EBR	WBL	WBT	WBR	NBL	NBT	NBR	SBL	SBT	SBR
Lane Configurations												
Ideal Flow (vphpl)	1750	1750	1750	1750	1750	1750	1750	1750	1750	1750	1750	1750
Storage Length (m)	15.0		0.0	0.0		0.0	0.0		0.0	0.0		0.0
Storage Lanes	1		0	0		0	0		0	0		0
Total Lost Time (s)	4.0	4.0	4.0	4.0	4.0	4.0	4.0	4.0	4.0	4.0	4.0	4.0
Turning Speed (k/h)	24		14	24		14	24		14	24		14
Lane Util. Factor	1.00	1.00	1.00	1.00	1.00	1.00	1.00	0.91	0.91	1.00	1.00	1.00
Ped Bike Factor	0.95							0.91				
Frt								0.953				
Flt Protected	0.950											
Satd. Flow (prot)	1612	1697	0	0	0	0	0	4005	0	0	0	0
Flt Permitted	0.950											
Satd. Flow (perm)	1529	1697	0	0	0	0	0	4005	0	0	0	0
Right Turn on Red	Yes		Yes			Yes			Yes			Yes
Satd. Flow (RTOR)	46							263				
Headway Factor	1.01	1.01	1.01	1.01	1.01	1.01	1.01	1.01	1.01	1.01	1.01	1.01
Link Speed (k/h)		30			30			50				50
Link Distance (m)		83.2			94.2			73.5				83.3
Travel Time (s)		10.0			11.3			5.3				6.0
Volume (vph)	191	159	0	0	0	0	0	526	242	0	0	0
Confl. Peds. (#/hr)	40		40	40		40	330		225	225		330
Confl. Bikes (#/hr)						78			19			
Peak Hour Factor	0.92	0.92	0.92	0.92	0.92	0.92	0.92	0.92	0.92	0.92	0.92	0.92
Adj. Flow (vph)	208	173	0	0	0	0	0	572	263	0	0	0
Lane Group Flow (vph)	208	173	0	0	0	0	0	835	0	0	0	0
Turn Type	Perm											
Protected Phases		4						2				
Permitted Phases	4											
Minimum Split (s)	23.0	23.0						35.0				
Total Split (s)	24.0	24.0	0.0	0.0	0.0	0.0	0.0	36.0	0.0	0.0	0.0	0.0
Total Split (%)	40.0%	40.0%	0.0%	0.0%	0.0%	0.0%	0.0%	60.0%	0.0%	0.0%	0.0%	0.0%
Maximum Green (s)	19.0	19.0						31.0				
Yellow Time (s)	3.3	3.3						3.3				
All-Red Time (s)	1.7	1.7						1.7				
Lead/Lag												
Lead-Lag Optimize?												
Walk Time (s)	7.0	7.0						19.0				
Flash Dont Walk (s)	7.0	7.0						6.0				
Pedestrian Calls (#/hr)	0	0						0				
Act Effct Green (s)	20.0	20.0						32.0				
Actuated g/C Ratio	0.33	0.33						0.53				
v/c Ratio	0.39	0.31						0.37				
Control Delay	15.8	18.1						5.9				
Queue Delay	0.0	0.0						0.0				
Total Delay	15.8	18.1						5.9				
LOS	B	B						A				
Approach Delay		16.8						5.9				
Approach LOS		B						A				

Intersection Summary

Area Type:	Other		
Cycle Length:	60		
Actuated Cycle Length:	60		
Offset:	26 (43%), Referenced to phase 2:NBT and 6:, Start of Green		
Natural Cycle:	60		
Control Type:	Pretimed		
Maximum v/c Ratio:	0.39		
Intersection Signal Delay:	9.3	Intersection LOS:	A
Intersection Capacity Utilization	39.2%	ICU Level of Service	A
Analysis Period (min)	15		

Splits and Phases: 1: Nepean & Metcalfe

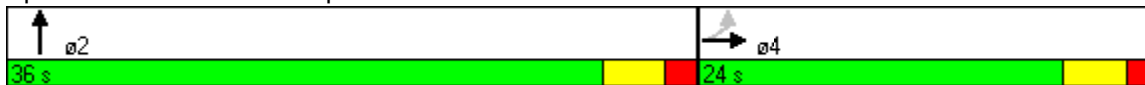



Lane Group	EBL	EBT	EBR	WBL	WBT	WBR	NBL	NBT	NBR	SBL	SBT	SBR
Lane Configurations		↑	↗								↑↑↑	
Ideal Flow (vphpl)	1750	1750	1750	1750	1750	1750	1750	1750	1750	1750	1750	1750
Storage Length (m)	0.0		15.0	0.0		0.0	0.0		0.0	0.0		0.0
Storage Lanes	0		1	0		0	0		0	0		0
Total Lost Time (s)	4.0	4.0	4.0	4.0	4.0	4.0	4.0	4.0	4.0	4.0	4.0	4.0
Turning Speed (k/h)	24		14	24		14	24		14	24		14
Lane Util. Factor	1.00	1.00	1.00	1.00	1.00	1.00	1.00	1.00	1.00	0.86	0.86	1.00
Ped Bike Factor			0.95									0.96
Frt			0.850									
Flt Protected												0.992
Satd. Flow (prot)	0	1697	1442	0	0	0	0	0	0	0	5790	0
Flt Permitted												0.992
Satd. Flow (perm)	0	1697	1372	0	0	0	0	0	0	0	5572	0
Right Turn on Red			Yes			Yes			Yes	Yes		Yes
Satd. Flow (RTOR)			7									114
Headway Factor	1.01	1.01	1.01	1.01	1.01	1.01	1.01	1.01	1.01	1.01	1.01	1.01
Link Speed (k/h)		30			30			50			50	
Link Distance (m)		109.5			95.0			73.8			82.4	
Travel Time (s)		13.1			11.4			5.3			5.9	
Volume (vph)	0	137	148	0	0	0	0	0	0	231	1220	0
Confl. Peds. (#/hr)	32		25	25		32	237		173	173		237
Confl. Bikes (#/hr)			12			1			13			
Peak Hour Factor	0.92	0.92	0.92	0.92	0.92	0.92	0.92	0.92	0.92	0.92	0.92	0.92
Adj. Flow (vph)	0	149	161	0	0	0	0	0	0	251	1326	0
Lane Group Flow (vph)	0	149	161	0	0	0	0	0	0	0	1577	0
Turn Type			Perm								Perm	
Protected Phases		4										6
Permitted Phases			4								6	
Minimum Split (s)		23.3	23.3							31.1	31.1	
Total Split (s)	0.0	26.0	26.0	0.0	0.0	0.0	0.0	0.0	0.0	34.0	34.0	0.0
Total Split (%)	0.0%	43.3%	43.3%	0.0%	0.0%	0.0%	0.0%	0.0%	0.0%	56.7%	56.7%	0.0%
Maximum Green (s)		20.7	20.7							28.9	28.9	
Yellow Time (s)		3.3	3.3							3.3	3.3	
All-Red Time (s)		2.0	2.0							1.8	1.8	
Lead/Lag												
Lead-Lag Optimize?												
Walk Time (s)		7.0	7.0							15.0	15.0	
Flash Dont Walk (s)		8.0	8.0							7.0	7.0	
Pedestrian Calls (#/hr)		0	0							0	0	
Act Effct Green (s)		22.0	22.0								30.0	
Actuated g/C Ratio		0.37	0.37								0.50	
v/c Ratio		0.24	0.32								0.55	
Control Delay		14.5	15.2								8.0	
Queue Delay		0.0	0.0								0.1	
Total Delay		14.5	15.2								8.1	
LOS		B	B								A	
Approach Delay		14.9									8.1	
Approach LOS		B									A	

Intersection Summary

Area Type:	Other
Cycle Length:	60
Actuated Cycle Length:	60
Offset:	7 (12%), Referenced to phase 2: and 6:SBTL, Start of Green
Natural Cycle:	55
Control Type:	Pretimed
Maximum v/c Ratio:	0.55
Intersection Signal Delay:	9.2
Intersection LOS:	A
Intersection Capacity Utilization	43.8%
ICU Level of Service	A
Analysis Period (min)	15

Splits and Phases: 13: Nepean & O'Connor





Lane Group	EBL	EBT	EBR	WBL	WBT	WBR	NBL	NBT	NBR	SBL	SBT	SBR
Lane Configurations					↑	↗		↖↖↖				
Ideal Flow (vphpl)	1750	1750	1750	1750	1750	1750	1750	1750	1750	1750	1750	1750
Storage Length (m)	0.0		0.0	0.0		15.0	0.0		0.0	0.0		0.0
Storage Lanes	0		0	0		1	0		0	0		0
Total Lost Time (s)	4.0	4.0	4.0	4.0	4.0	4.0	4.0	4.0	4.0	4.0	4.0	4.0
Turning Speed (k/h)	24		14	24		14	24		14	24		14
Lane Util. Factor	1.00	1.00	1.00	1.00	1.00	1.00	0.91	0.91	1.00	1.00	1.00	1.00
Ped Bike Factor						0.87		0.95				
Frt						0.850						
Flt Protected								0.983				
Satd. Flow (prot)	0	0	0	0	1697	1442	0	4553	0	0	0	0
Flt Permitted								0.983				
Satd. Flow (perm)	0	0	0	0	1697	1259	0	4343	0	0	0	0
Right Turn on Red			Yes			Yes	Yes		Yes			Yes
Satd. Flow (RTOR)						114		161				
Headway Factor	1.01	1.01	1.01	1.01	1.01	1.01	1.01	1.01	1.01	1.01	1.01	1.01
Link Speed (k/h)		50			50			50			50	
Link Distance (m)		182.2			96.8			83.3			76.7	
Travel Time (s)		13.1			7.0			6.0			5.5	
Volume (vph)	0	0	0	0	218	105	224	429	0	0	0	0
Confl. Peds. (#/hr)	54		59	59		54	112		267	267		112
Confl. Bikes (#/hr)						60						9
Peak Hour Factor	0.92	0.92	0.92	0.92	0.92	0.92	0.92	0.92	0.92	0.92	0.92	0.92
Adj. Flow (vph)	0	0	0	0	237	114	243	466	0	0	0	0
Lane Group Flow (vph)	0	0	0	0	237	114	0	709	0	0	0	0
Turn Type						Perm	Perm					
Protected Phases					8			2				
Permitted Phases						8	2					
Minimum Split (s)					19.0	19.0	30.0	30.0				
Total Split (s)	0.0	0.0	0.0	0.0	19.0	19.0	41.0	41.0	0.0	0.0	0.0	0.0
Total Split (%)	0.0%	0.0%	0.0%	0.0%	31.7%	31.7%	68.3%	68.3%	0.0%	0.0%	0.0%	0.0%
Maximum Green (s)					14.0	14.0	36.0	36.0				
Yellow Time (s)					3.3	3.3	3.3	3.3				
All-Red Time (s)					1.7	1.7	1.7	1.7				
Lead/Lag												
Lead-Lag Optimize?												
Walk Time (s)					7.0	7.0	19.0	19.0				
Flash Dont Walk (s)					7.0	7.0	6.0	6.0				
Pedestrian Calls (#/hr)					20	20	40	40				
Act Effct Green (s)					15.0	15.0		37.0				
Actuated g/C Ratio					0.25	0.25		0.62				
v/c Ratio					0.56	0.28		0.26				
Control Delay					25.6	6.6		3.8				
Queue Delay					0.0	0.0		0.0				
Total Delay					25.6	6.6		3.8				
LOS					C	A		A				
Approach Delay					19.4			3.8				
Approach LOS					B			A				

Intersection Summary

Area Type:	Other		
Cycle Length:	60		
Actuated Cycle Length:	60		
Offset:	33 (55%), Referenced to phase 2:NBTL and 6:., Start of Green		
Natural Cycle:	50		
Control Type:	Pretimed		
Maximum v/c Ratio:	0.56		
Intersection Signal Delay:	8.9	Intersection LOS:	A
Intersection Capacity Utilization	40.0%	ICU Level of Service	A
Analysis Period (min)	15		

Splits and Phases: 15: Gloucester & Metcalfe

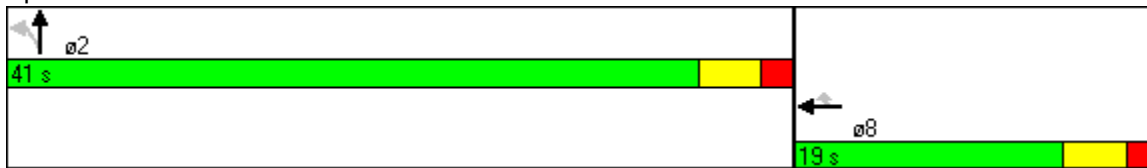





Lane Group	EBL	EBT	EBR	WBL	WBT	WBR	NBL	NBT	NBR	SBL	SBT	SBR
Lane Configurations				↙	↘						↑↑↑	
Ideal Flow (vphpl)	1750	1750	1750	1750	1750	1750	1750	1750	1750	1750	1750	1750
Storage Length (m)	0.0		0.0	15.0		0.0	0.0		0.0	0.0		0.0
Storage Lanes	0		0	1		0	0		0	0		0
Total Lost Time (s)	4.0	4.0	4.0	4.0	4.0	4.0	4.0	4.0	4.0	4.0	4.0	4.0
Turning Speed (k/h)	24		14	24		14	24		14	24		14
Lane Util. Factor	1.00	1.00	1.00	1.00	1.00	1.00	1.00	1.00	1.00	1.00	0.86	0.86
Ped Bike Factor				0.96							0.98	
Frt											0.984	
Flt Protected				0.950								
Satd. Flow (prot)	0	0	0	1612	1697	0	0	0	0	0	5633	0
Flt Permitted				0.950								
Satd. Flow (perm)	0	0	0	1540	1697	0	0	0	0	0	5633	0
Right Turn on Red			Yes	Yes		Yes			Yes			Yes
Satd. Flow (RTOR)				35							73	
Headway Factor	1.01	1.01	1.01	1.01	1.01	1.01	1.01	1.01	1.01	1.01	1.01	1.01
Link Speed (k/h)		50			50			50			50	
Link Distance (m)		108.3			182.2			82.4			78.3	
Travel Time (s)		7.8			13.1			5.9			5.6	
Volume (vph)	0	0	0	324	216	0	0	0	0	0	947	114
Confl. Peds. (#/hr)	198		37	37		198	105		138	138		105
Confl. Bikes (#/hr)			34			1						29
Peak Hour Factor	0.92	0.92	0.92	0.92	0.92	0.92	0.92	0.92	0.92	0.92	0.92	0.92
Adj. Flow (vph)	0	0	0	352	235	0	0	0	0	0	1029	124
Lane Group Flow (vph)	0	0	0	352	235	0	0	0	0	0	1153	0
Turn Type				Perm								
Protected Phases					8						6	
Permitted Phases				8								
Minimum Split (s)				25.0	25.0						35.0	
Total Split (s)	0.0	0.0	0.0	25.0	25.0	0.0	0.0	0.0	0.0	0.0	35.0	0.0
Total Split (%)	0.0%	0.0%	0.0%	41.7%	41.7%	0.0%	0.0%	0.0%	0.0%	0.0%	58.3%	0.0%
Maximum Green (s)				19.7	19.7						29.9	
Yellow Time (s)				3.3	3.3						3.3	
All-Red Time (s)				2.0	2.0						1.8	
Lead/Lag												
Lead-Lag Optimize?												
Walk Time (s)				7.0	7.0						15.0	
Flash Dont Walk (s)				8.0	8.0						7.0	
Pedestrian Calls (#/hr)				20	20						40	
Act Effct Green (s)				21.0	21.0						31.0	
Actuated g/C Ratio				0.35	0.35						0.52	
v/c Ratio				0.63	0.40						0.39	
Control Delay				14.9	11.9						8.6	
Queue Delay				0.0	0.0						0.0	
Total Delay				14.9	11.9						8.6	
LOS				B	B						A	
Approach Delay					13.7						8.6	
Approach LOS					B						A	

Intersection Summary

Area Type:	Other		
Cycle Length:	60		
Actuated Cycle Length:	60		
Offset:	1 (2%), Referenced to phase 2: and 6:SBT, Start of Green		
Natural Cycle:	60		
Control Type:	Pretimed		
Maximum v/c Ratio:	0.63		
Intersection Signal Delay:	10.4	Intersection LOS:	B
Intersection Capacity Utilization	44.5%	ICU Level of Service	A
Analysis Period (min)	15		

Splits and Phases: 16: Gloucester & O'Connor



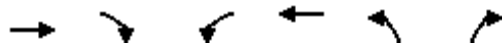

Movement	EBT	EBR	WBL	WBT	NBL	NBR
Lane Configurations	↶					↷
Sign Control	Free			Free	Stop	
Grade	0%			0%	0%	
Volume (veh/h)	343	34	0	0	0	48
Peak Hour Factor	0.92	0.92	0.92	0.92	0.92	0.92
Hourly flow rate (vph)	373	37	0	0	0	52
Pedestrians						
Lane Width (m)						
Walking Speed (m/s)						
Percent Blockage						
Right turn flare (veh)						
Median type					None	
Median storage (veh)						
Upstream signal (m)	99			83		
pX, platoon unblocked						
vC, conflicting volume			410		391	391
vC1, stage 1 conf vol						
vC2, stage 2 conf vol						
vCu, unblocked vol			410		391	391
tC, single (s)			4.1		6.4	6.2
tC, 2 stage (s)						
tF (s)			2.2		3.5	3.3
p0 queue free %			100		100	92
cM capacity (veh/h)			1149		613	657

Direction, Lane #	EB 1	NB 1
Volume Total	410	52
Volume Left	0	0
Volume Right	37	52
cSH	1700	657
Volume to Capacity	0.24	0.08
Queue Length 95th (m)	0.0	2.0
Control Delay (s)	0.0	10.9
Lane LOS		B
Approach Delay (s)	0.0	10.9
Approach LOS		B

Intersection Summary			
Average Delay		1.2	
Intersection Capacity Utilization	31.8%	ICU Level of Service	A
Analysis Period (min)		15	

## **APPENDIX E**

---

### **Traffic Signal Justification Calculations**



## TRAFFIC SIGNAL JUSTIFICATION USING PROJECTED VOLUMES

LOCATION: Metcalfe Street at Nepean Street

YEAR: 2013 Projected Background Traffic

JUSTIFICATION	DESCRIPTION	MINIMUM REQUIREMENT		COMPLIANCE		
		FREE FLOW	RESTRICTED FLOW	SECTIONAL		ENTIRE % <sup>(2)</sup>
		OPERATING SPEED ≥ 70KM/H	OPERATING SPEED < 70 KM/H	NUMERICAL	PERCENT	
<b>1. MINIMUM VEHICULAR WARRANT</b>	A. Vehicle volume, all approaches (average hour)	480 600 (2 or more lane approach)	720 900 2 or more lane approach	618	69%	<b>69%</b>
	B. Vehicle volume along minor street (average hour)	120 180 (tee intersection)	170 255 (tee intersection)	146	76%	
<b>2. DELAY TO CROSS TRAFFIC</b>	A. Vehicle volume along major street (average hour)	480 600 (2 or more lane approach)	720 900 2 or more lane approach	472	52%	<b>52%</b>
	B <sup>(1)</sup> . Combined vehicle and pedestrian volume <u>crossing</u> the major street (average hour)	50	75	89	100%	

## TRAFFIC SIGNAL JUSTIFICATION USING PROJECTED VOLUMES



LOCATION: Metcalfe Street at Nepean Street

YEAR: 2013 Projected Total Traffic

JUSTIFICATION	DESCRIPTION	MINIMUM REQUIREMENT		COMPLIANCE		
		FREE FLOW	RESTRICTED FLOW	SECTIONAL		ENTIRE % <sup>(2)</sup>
		OPERATING SPEED ≥ 70KM/H	OPERATING SPEED < 70 KM/H	NUMERICAL	PERCENT	
<b>1. MINIMUM VEHICULAR WARRANT</b>	A. Vehicle volume, all approaches (average hour)	480 600 (2 or more lane approach)	720 900 2 or more lane approach	639	71%	<b>71%</b>
	B. Vehicle volume along minor street (average hour)	120 180 (tee intersection)	170 255 (tee intersection)	163	96%	
<b>2. DELAY TO CROSS TRAFFIC</b>	A. Vehicle volume along major street (average hour)	480 600 (2 or more lane approach)	720 900 2 or more lane approach	476	53%	<b>53%</b>
	B <sup>(1)</sup> . Combined vehicle and pedestrian volume <u>crossing</u> the major street (average hour)	50	75	91	100%	

**NOTES**

- 1) For definition of crossing volume refer to the Ontario Traffic Manual Book 12, Section 4.5 (Nov. 2007).
- 2) The lowest sectional percentage governs the entire Justification.
- 3) Average hourly volumes estimated from peak hour volumes,  $AHV = PM / 2$  or  $AHV = (AM + PM) / 4$ .

## TRAFFIC SIGNAL JUSTIFICATION SUMMARY TABLE

LOCATION:     O'Connor Street     at     Nepean Street    

DATE:     October 19, 2011    

JUSTIFICATION	DESCRIPTION	MINIMUM REQUIREMENT		COMPLIANCE	
		FREE FLOW	RESTRICTED FLOW	SECTIONAL %	ENTIRE % <sup>(2)</sup>
		OPERATING SPEED ≥ 70KM/H	OPERATING SPEED < 70 KM/H		
<b>1. MINIMUM VEHICULAR WARRANT</b>	A. Vehicle volume, all approaches for each of the heaviest 8 hours of an average day, and	480 600 (2 or more lane approach)	720 900 (2 or more lane approach)		
	B. Vehicle volume, along minor street, for each of the same 8 hours.	120 180 (tee intersection)	170 255 (tee intersection)		
<b>2. DELAY TO CROSS TRAFFIC</b>	A. Vehicle volume, along major street for each for the heaviest 8 hours of an average day, and	480 600 (2 or more lane approach)	720 900 (2 or more lane approach)		
	B <sup>(1)</sup> . Combined vehicle and pedestrian volume <u>crossing</u> the major street for each of the same 8 hours	50	75		
<b>3. VOLUME/DELAY COMBINATION</b>	The above Justifications (1 and 2) both satisfied to the extent of 80% or more	Yes <input type="checkbox"/>		No <input type="checkbox"/>	
<b>4. MINIMUM FOUR HOUR VEHICLE VOLUME</b>	Plotted point representing hourly volume for minor approach vs. major approach for four highest hours of an average day fall above the applicable curve	Yes <input type="checkbox"/>		No <input type="checkbox"/>	
<b>5. COLLISION EXPERIENCE</b>	A. Total reported accidents of types susceptible to correction by a traffic signal, per 12 month period averaged over a 36 month period, and	5		4.33	<b>86%</b>
	B. Adequate trial of less restrictive remedies, where satisfactory observance and enforcement have failed to reduce the number of accidents	Yes <input type="checkbox"/>		No <input checked="" type="checkbox"/>	
<b>6. PEDESTRIAN VOLUME AND DELAY</b>	A. Plotted point representing 8 hour pedestrian volume vs. 8 hour vehicular volume fall in justified zone, and	Yes <input type="checkbox"/>		No <input type="checkbox"/>	
	B. Plotted point representing 8 hour volume of pedestrian experiencing delays of 10 s or more vs. 8 hour pedestrian volume fall in justified zone	Yes <input type="checkbox"/>		No <input type="checkbox"/>	

**NOTES**

- 1) For definition of crossing volume refer to the Ontario Traffic Manual Book 12, Section 4.5 (Nov. 2007).
- 2) The lowest sectional percentage governs the entire Justification.

### TRAFFIC SIGNAL JUSTIFICATION USING PROJECTED VOLUMES

LOCATION: O'Connor Street at Nepean Street

YEAR: 2013 Projected Background Traffic

JUSTIFICATION	DESCRIPTION	MINIMUM REQUIREMENT		COMPLIANCE		
		FREE FLOW	RESTRICTED FLOW	SECTIONAL		ENTIRE % <sup>(2)</sup>
		OPERATING SPEED ≥ 70KM/H	OPERATING SPEED < 70 KM/H	NUMERICAL	PERCENT	
<b>1. MINIMUM VEHICULAR WARRANT</b>	A. Vehicle volume, all approaches (average hour)	480 600 (2 or more lane approach)	720 900 (2 or more lane approach)	667	74%	<b>66%</b>
	B. Vehicle volume along minor street (average hour)	120 180 (tee intersection)	170 255 (tee intersection)	112	66%	
<b>2. DELAY TO CROSS TRAFFIC</b>	A. Vehicle volume along major street (average hour)	480 600 (2 or more lane approach)	720 900 (2 or more lane approach)	555	62%	<b>62%</b>
	B <sup>(1)</sup> . Combined vehicle and pedestrian volume <u>crossing</u> the major street (average hour)	50	75	82	100%	

### TRAFFIC SIGNAL JUSTIFICATION USING PROJECTED VOLUMES

LOCATION: O'Connor Street at Nepean Street

YEAR: 2013 Projected Total Traffic

JUSTIFICATION	DESCRIPTION	MINIMUM REQUIREMENT		COMPLIANCE		
		FREE FLOW	RESTRICTED FLOW	SECTIONAL		ENTIRE % <sup>(2)</sup>
		OPERATING SPEED ≥ 70KM/H	OPERATING SPEED < 70 KM/H	NUMERICAL	PERCENT	
<b>1. MINIMUM VEHICULAR WARRANT</b>	A. Vehicle volume, all approaches (average hour)	480 600 (2 or more lane approach)	720 900 (2 or more lane approach)	684	76%	<b>67%</b>
	B. Vehicle volume along minor street (average hour)	120 180 (tee intersection)	170 255 (tee intersection)	114	67%	
<b>2. DELAY TO CROSS TRAFFIC</b>	A. Vehicle volume along major street (average hour)	480 600 (2 or more lane approach)	720 900 (2 or more lane approach)	570	63%	<b>63%</b>
	B <sup>(1)</sup> . Combined vehicle and pedestrian volume <u>crossing</u> the major street (average hour)	50	75	83	100%	

**NOTES**

- 4) For definition of crossing volume refer to the Ontario Traffic Manual Book 12, Section 4.5 (Nov. 2007).
- 5) The lowest sectional percentage governs the entire Justification.
- 6) Average hourly volumes estimated from peak hour volumes, AHV = PM / 2 or AHV = (AM + PM) / 4.

## **APPENDIX F**

---

**Excerpts of CTS / TIS produced for  
Residential/Retail developments at 187 Metcalfe Street  
(Revised February 2010), 89-91 Nepean Street (October 2010) and 70  
Gloucester Street (February 2011)**



### 3.2 General Background Growth

A compound annual growth rate of 1.0% was confirmed with City staff for future background traffic projections at all study area intersections.

Background traffic volumes for the 2012 and 2017 time horizons were estimated by applying the 1% growth rate to the most recent traffic count data available at all study area intersections.

The 2012 and 2017 background traffic projections are shown in Figures 6 and 7 respectively.

### 3.3 Trip Generation

Trips generated by the proposed residential dwelling units and grocery store have been estimated using peak hour rates identified in the *Institute of Transportation Engineers (ITE) Trip Generation Manual, 8<sup>th</sup> Edition*. As in the original TIS submission, an adjustment factor of 0.70 has been applied to the ITE trip generation rates to reflect the non-auto modal share of the Ottawa Inner Area.

It is anticipated that the 3,230 ft<sup>2</sup> (300 m<sup>2</sup>) daycare centre will primarily serve residents of the development however service will be offered to members of the surrounding community if space permits. The majority of trips generated by the daycare center are assumed to be non-auto trips and for the purpose of this analysis the daycare has not been included in the peak hour vehicle trip calculations.

The peak hour vehicle trips generated by the development are outlined in the following table.

**Table 2: Trip Generation**

Land Use	ITE Code	Units	AM Peak	PM Peak
Residential Condos/Towns	232	453	20 in/ 92 out	73 in/47 out
Supermarket	850	25,091 ft <sup>2</sup>	40 in/ 25 out	93 in/ 92 out
<b>Total Trips</b>			<b>60 in/ 117 out</b>	<b>166 in/ 139 out</b>

1. ITE trip generation rates have been adjusted using a non-auto modal share factor of 0.70.

The grocery store is expected to generate two types of peak hour trips: primary trips and pass-by trips. Primary trips are made for the specific purpose of visiting the site and pass-by trips are made as an intermediate stop on the way to another destination. The pass-by trips have not been added to the study area intersections as these motorists are already using the adjacent street system. Peak hour pass-by trips have been estimated based on percentages identified in the *ITE Trip Generation Handbook* for the supermarket land use. A pass-by rate of 30% was confirmed with City staff for use in this study.

Primary and pass-by trips generated by the proposed grocery store are identified in the following table.

**Table 3: Primary and Pass-by Trips**

Land Use	AM Peak	PM Peak
Total Trips	40 in/ 25 out	93 in/ 92 out
Pass-by Trips	10 in/ 10 out	30 in/ 30 out
Primary Trips	30 in/ 15 out	63 in/ 62 out

It is assumed that vehicles accessing the existing surface parking lot will seek parking at other locations within the surrounding area. Traffic volumes currently using the surface lot are expected to continue passing through study area intersections to reach their ultimate destinations. Background volumes at study area intersections have not been adjusted to account for the removal of the surface parking lot.

### 3.4 Trip Distribution

The distribution of primary trips generated by the development was determined based on the existing traffic patterns and the location of the site access with respect to the adjacent roadway system.

The distribution of primary trips is summarized as follows:

- 35% to/from the north
- 35% to/from the south
- 15% to/from the west
- 15% to/from the east

The distribution of pass-by trips was determined based on the volume of traffic travelling through the study area in the weekday a.m. and p.m. peak hours.



The primary and pass-by trip distributions for the weekday a.m. and p.m. peak hours are shown in Figures 8 and 9.

Total traffic volumes for 2012 and 2017 have been calculated by adding the estimated site generated traffic with the background traffic projections. The 2012 and 2017 total traffic volumes are shown in Figures 10 and 11.

## 4.0 INTERSECTION ANALYSIS

Intersection capacity analysis has been completed using the Synchro 6.0 software package. Operating conditions at signalized intersections have been evaluated in terms of the volume to capacity (v/c) ratio and the corresponding Level of Service (LOS) based on City of Ottawa criteria. Operating conditions at unsignalized intersections have been evaluated in terms of delay and LOS

# LEGEND

-  Signalized Intersection    xxx (xxx) AM (PM) flow, veh/hr
-  Unsignalized Intersection    — One-way street

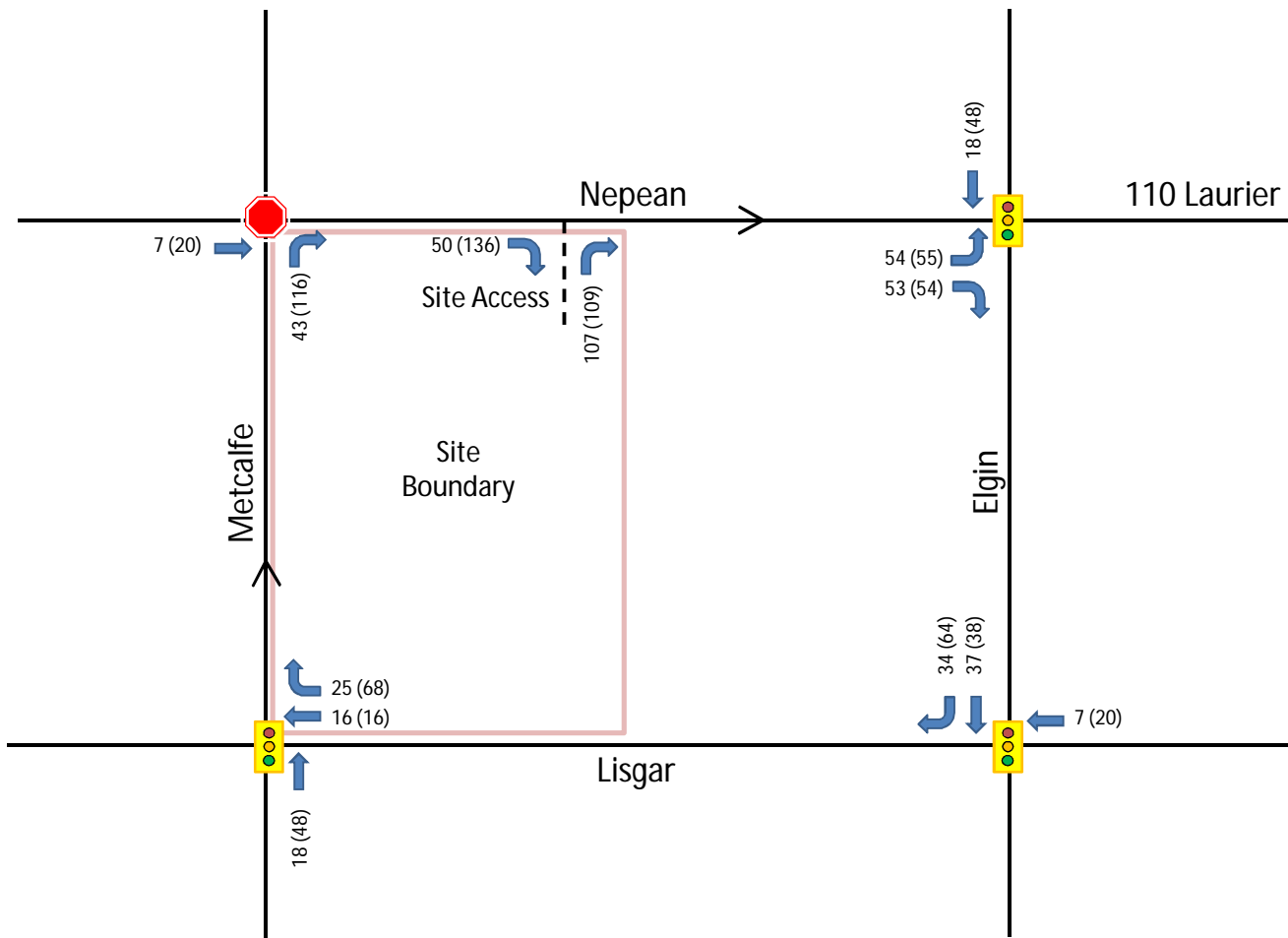
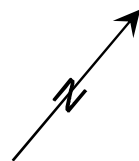

# NOVATECH

ENGINEERING  
CONSULTANTS LTD.

ENGINEERS & PLANNERS

Suite 200, 240 Michael Cowpland Drive  
Ottawa, Ontario, Canada  
K2M 1P6



Telephone: (613) 254-9643  
Facsimile: (613) 254-5867  
Email: novainfo@novatech-eng.com

187 METCALFE STREET

PRIMARY TRIPS

FEB 2010 108020 FIGURE 8

# LEGEND

-  Signalized Intersection    xxx (xxx) AM (PM) flow, veh/hr
-  Unsignalized Intersection    — One-way street

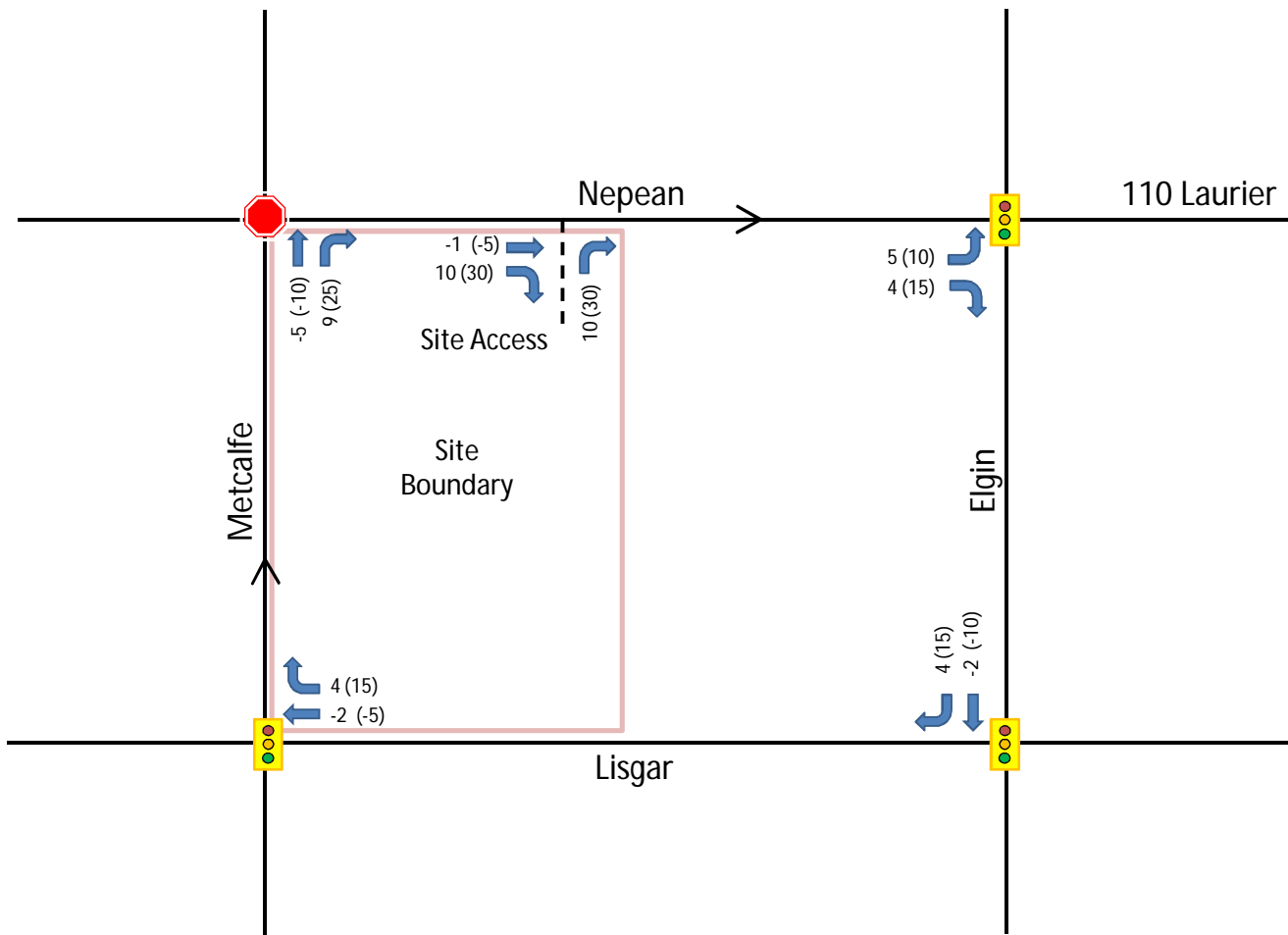
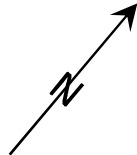

# NOVATECH

ENGINEERING  
CONSULTANTS LTD.

ENGINEERS & PLANNERS

Suite 200, 240 Michael Cowpland Drive  
Ottawa, Ontario, Canada  
K2M 1P6

Telephone: (613) 254-9643  
Facsimile: (613) 254-5867  
Email: novainfo@novatech-eng.com

187 METCALFE STREET

PASS-BY TRIPS

FEB 2010 108020 FIGURE 9

### 3.3 Other Planned Developments

A high density residential/commercial development is currently under construction at 187 Metcalfe Street, which is located approximately 75 metres southeast of the subject site. This development shall consist of two 27-storey and one 7-storey condominium towers, a 2,330m<sup>2</sup> grocery store, and a 300m<sup>2</sup> daycare centre. The development is to be constructed in 3 phases, with full completion scheduled for 2013.

NECL produced a combined CTS/Revised TIS in February 2010 in support of a Zoning By-law Amendment application for this development. This study estimated that at full buildout, the development would generate 177 two-way trips in the AM peak hour and 305 two-way trips in the PM peak hour. An excerpt of this report detailing the trip generation of the proposed development, and the distribution of those trips throughout the adjacent road network, is included in this report as Appendix F.

For the purposes of this study, all trips that will be generated by the 187 Metcalfe development are considered to be part of future background traffic. To account for this, the trip distribution volumes shown in Figure 7 have been included as part of the 2013 and 2018 background traffic volumes that are shown in Figures 8 and 9 respectively.

### 3.4 Trip Generation

Trips generated by the proposed residential dwelling units and commercial floor space have been estimated using relevant peak hour rates identified in the *Institute of Transportation Engineers (ITE) Trip Generation Manual, 8<sup>th</sup> Edition*. The specific land use of the commercial land use is unknown at this time, so it has been conservatively assumed that it will be developed as a convenience market (Mac's or similar). This land use is considered to be one of the most intensive trip generators that could be feasibly contained within the floor space area available. On this basis, the following trip generation calculations are considered to be robust. The trip generation is based on full development as shown in the site plan. The peak hour vehicle trips generated by the proposed development are outlined in the following table.

**Table 2: ITE Trip Generation**

Land Use	ITE Code	Units/GFA	Trip Rates		Vehicle Trips	
			AM Peak	PM Peak	AM Peak	PM Peak
High Rise Residential Condominiums	232	233	Equation <sup>1</sup>	Equation <sup>2</sup>	96 vph	94 vph
Convenience Market (open 15-16hrs)	852	1200 ft <sup>2</sup>	31.02	34.57	37 vph	41 vph
<b>Total Trips</b>					<b>133 vph</b>	<b>135 vph</b>

1. ITE Trip Equation:  $T = 0.29x + 28.86$ , where  $x$  = number of units

2. ITE Trip Equation:  $T = 0.34x + 15.47$ , where  $x$  = number of units

3. vph = vehicles per hour

Based on the relevant ITE trip rates, the proposed development is expected to generate between 133 vph and 135 vph during peak hours. The trip generation surveys compiled in the *ITE Trip Generation Manual* only record vehicle trips, and the sites surveyed are typically located in suburban locations in the United States where non-auto modes of transportation typically have a modal share of 10% or less. For urban infill developments in downtown locations such as Nepean Street, where multiple modes of transportation are readily available, it is considered good practice to express projected trip generation volumes in terms of person trips, instead of vehicle trips. To convert ITE vehicle trip rates to person trip rates, two adjustment factors have been applied:

- Vehicle occupancy factor: **1.23** (taken from the TRANS 2005 O-D Survey Report)
- Non-auto usage factor: **1.1** (non-auto trips not counted in ITE surveys, assumed 10%)

Combining the two factors gives an overall vehicle trip to person trip adjustment factor of approximately 1.35. Applying this factor to the vehicle trips projected by the ITE rates, the site is expected to generate 180 and 182 person trips during the AM and PM peak hours respectively.

**Table 3: Person Trips**

Land Use	Vehicle Trips		→	Person Trips	
	AM Peak	PM Peak		AM Peak	PM Peak
High-rise Residential Condominiums	96 pph	94 pph	→	130 pph	127 pph
Convenience Market (open 15-16hrs)	37 pph	41 pph		50 pph	55 pph
<b>Total Trips</b>	<b>133 vph</b>	<b>135 vph</b>		<b>180 vph</b>	<b>182 vph</b>

1. Internal Rate of Capture = 4%

The convenience market is expected to generate two types of peak hour trips: primary trips and pass-by trips. Primary trips are made for the specific purpose of visiting the site and pass-by trips are made as an intermediate stop on the way to another destination. Peak hour pass-by trips have been estimated based a pass-by rate of 60%. The *ITE Trip Generation Handbook* identifies this percentage as an average for the Convenience Market land use. The pass-by trips generated by the convenience store are part of the observed background traffic, and as such do not constitute 'new' trips on the adjacent road network. Applying a 60% pass-by reduction to the trips generated by the convenience store, it is estimated that the site will generate between 149 and 150 primary (i.e. new) person trips during peak hours. The primary and pass-by trip generation is summarized in the following table.

**Table 4: Primary and Pass-By Trips**

Land Use	Person Trips		→	Primary Trips		Pass-By Trips	
	AM Peak	PM Peak		AM Peak	PM Peak	AM Peak	PM Peak
High-rise Residential Condominiums	130 pph	127 pph	→	130 pph	127 pph	0 pph	0 pph
Convenience Market (open 15-16hrs)	50 pph	55 pph		20 pph	22 pph	30 pph	33 pph
<b>Total Trips</b>	<b>180 pph</b>	<b>182 pph</b>		<b>150 pph</b>	<b>149 pph</b>	<b>30 pph</b>	<b>33 pph</b>

1. pph = persons per hour

Due to the nature of the proposed land uses of the development, it is anticipated that some of the total volume of site-generated trips will be internally captured within the site. In this case, a typical example of an internally captured trip would be someone who lives in one of the proposed residential units making a trip downstairs to buy groceries at the proposed convenience store, and then returning home. The origin and destination of this trip is contained entirely within the site and does not show up on the adjacent street network.

The subject site is located in a downtown environment, and the internal capture rates presented in the *ITE Trip Generation Handbook* are 'applicable only to sites outside the traditional downtown'. In the absence of any local data, the primary trips generated by the proposed development during the AM and PM peak hours have been reduced by 4% to account for internal capture.

This percentage has been derived by assuming that 15% of the primary trips generated by the convenience store will have an origin and destination within the adjoining residential tower. The internally captured trips must be balanced between the two land uses, which in this case would mean that 2% of the primary trips generated by the residential tower will be destined for the adjoining convenience store. During the AM and PM peak hours, this equates to 6 person trips being internally captured within the subject site, which is approximately 4% of the total volume of primary trips.

**Table 5: External Trips**

Land Use	Primary Trips <sup>1</sup>		→	Internal Primary Trips		External Primary Trips	
	AM Peak	PM Peak		AM Peak	PM Peak	AM Peak	PM Peak
High-rise Residential Condominiums	130 pph	127 pph		3 pph	3 pph	127 pph	124 pph
Convenience Market (open 15-16hrs)	20 pph	22 pph		3 pph	3 pph	17 pph	19 pph
<b>Total Trips</b>	<b>150 pph</b>	<b>149 pph</b>		<b>6 pph</b>	<b>6 pph</b>	<b>144 pph</b>	<b>143 pph</b>

After making adjustments to account for internal capture, it is estimated that the site will generate between 144 and 143 primary person trips during peak hours that are external, i.e. trips that will show up on the adjacent street network.

The number of car trips that the site will generate has been estimated by categorising the external primary trips and pass-by trips by modal share. The modal shares are based on observed percentages in the *2005 Trans O-D Survey Report* that are specific to the region referred to as the Ottawa Inner Area. The Ottawa Inner Area is close to major centres of retail and employment, has well developed transit facilities, and an extensive sidewalk network. This is reflected in the relatively high observed modal share for non-auto transportation. The modal share values applied to trips generated by the convenience store relate specifically to observed trips that had an origin and destination within the Ottawa Inner Area, as it is considered extremely unlikely that the convenience store will generate a statistically significant volume of trips with an origin or destination beyond the Ottawa Inner Area. The modal shares for trips generated by the residential units relate to all observed trips within the Ottawa Inner Area, including those with an origin or destination beyond that area.

A full breakdown of the projected person trips by modal share and arrival/departure is given in the table below.

**Table 6: Site-Generated Trips by Modal Share**

Travel Mode	Modal Share		AM Peak		PM Peak	
	R*	C*	Primary	Pass-By	Primary	Pass-By
Total Person Trips			144 pph 34 in, 110 out	30 pph 18 in, 12 out	143 pph 86 in, 57 out	33 pph 17 in, 16 out
Non-Motorized	10%	55%	22 pph 7 in, 15 out	16 pph 10 in, 6 out	23 pph 12 in, 11 out	18 pph 9 in, 9 out
Transit	30%	15%	41 pph 9 in, 32 out	5 pph 3 in, 2 out	40 pph 25 in, 15 out	5 pph 3 in, 2 out
Car Passenger	10%	5%	14 pph 3 in, 11 out	2 pph 1 in, 1 out	13 pph 8 in, 5 out	2 pph 1 in, 1 out
<b>Car Driver</b>	<b>50%</b>	<b>25%</b>	<b>67 vph</b> <b>15 in, 52 out</b>	<b>7 vph</b> <b>4 in, 3 out</b>	<b>67 vph</b> <b>41 in, 26 out</b>	<b>8 vph</b> <b>4 in, 4 out</b>

\*R = Residential Units; C = Convenience Store

The above table shows that the proposed development is expected to generate 67 primary car trips in both the AM peak and PM peak hour. The development is expected to generate 7 and 8 pass-by car trips in the weekday AM and PM peak hours respectively.

### 3.5 Trip Distribution

The distribution of primary trips generated by the development was determined based on the existing traffic patterns and the location of the site access with respect to the adjacent roadway system.

The distribution of primary trips is summarized as follows:

- 35% to/from the north,
- 35% to/from the south,
- 15% to/from the west,
- 15% to/from the east.

The proposed development is not expected to generate enough pass-by car trips to allow for any meaningful distribution based on current traffic patterns. All pass-by trips generated during the weekday AM and PM peak hours have been assumed to come from the existing eastbound traffic on Nepean Street passing the site.

The primary and pass-by trip distributions for the weekday AM and PM peak hours are shown in Figures 10 and 11.

Total traffic volumes for 2013 and 2018 have been calculated by adding the estimated site generated traffic with the background traffic projections. The 2013 and 2018 total traffic volumes are shown in Figures 12 and 13.



**NOVATECH**  
**ENGINEERING**  
**CONSULTANTS LTD.**  
 ENGINEERS & PLANNERS  
 Suite 200, 240 Michael Cowpland Drive  
 Ottawa, Ontario, Canada  
 K2M 1P6  
 Telephone (613) 254-9643  
 Facsimile (613) 254-5867  
 Email: novainto@novatech-eng.com

**LEGEND**

- Unsignalized Intersection
- Signalized Intersection
- xx VPH AM Peak Hour
- (xx) VPH PM Peak Hour

**89-91 NEPEAN STREET**  
**PRIMARY SITE TRAFFIC**  
 OCT 2010 110182 **FIGURE 10**

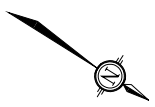
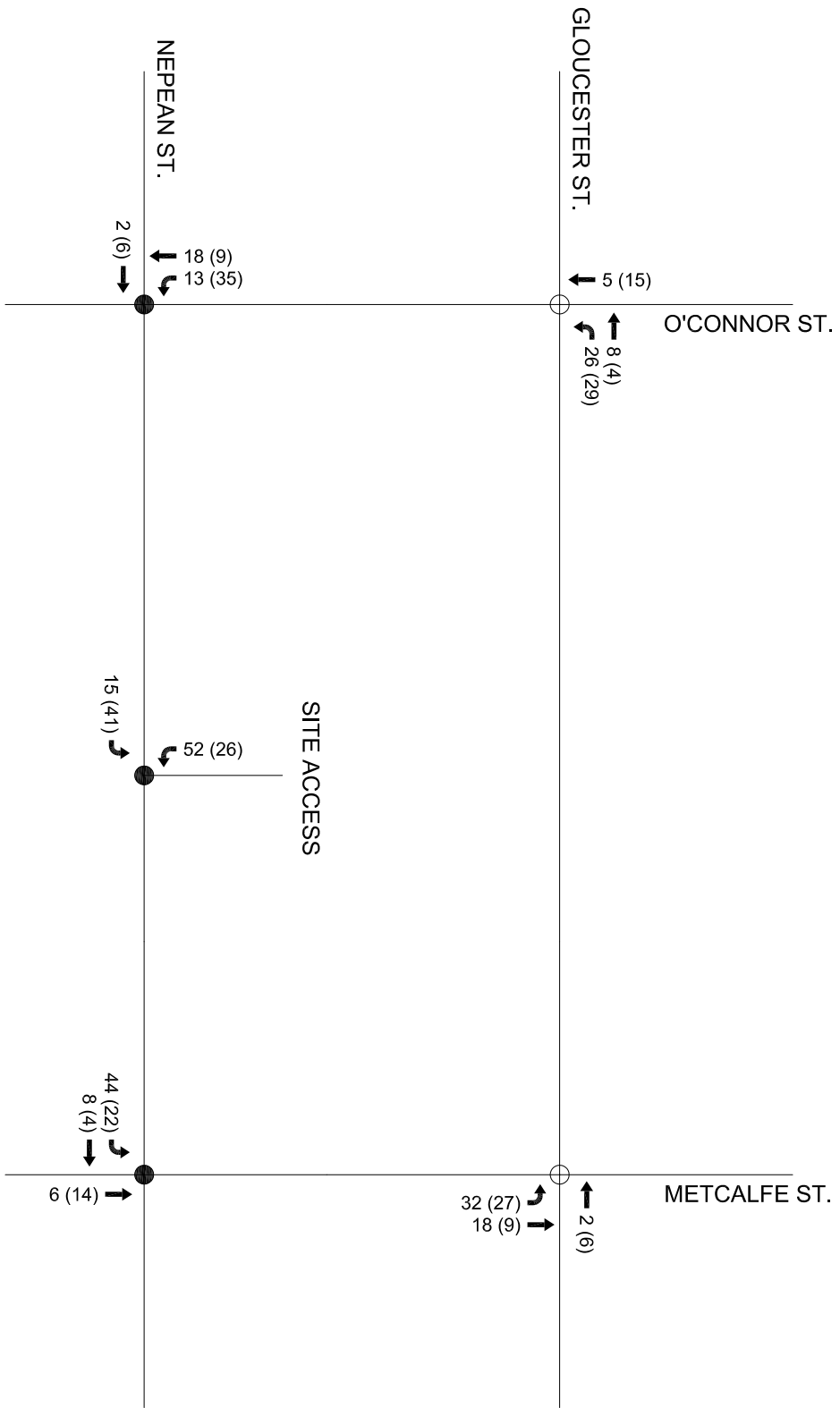

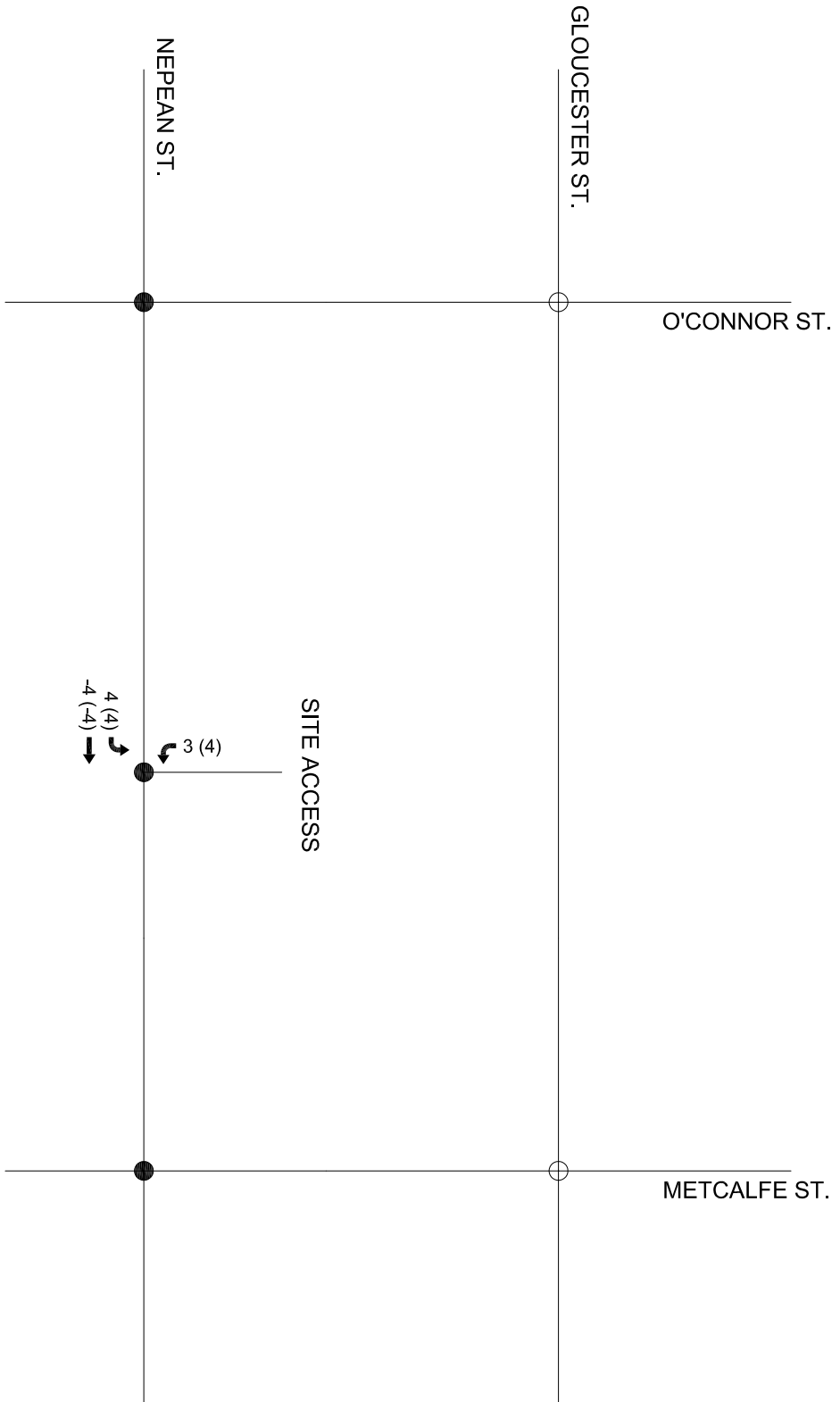

**NOVATECH**  
**ENGINEERING**  
**CONSULTANTS LTD.**  
 ENGINEERS & PLANNERS  
 Suite 200, 240 Michael Cowpland Drive  
 Ottawa, Ontario, Canada  
 K2M 1P6  
 Telephone (613) 254-9643  
 Facsimile (613) 254-5867  
 Email: novainto@novatech-eng.com

LEGEND	
●	Unsignalized Intersection
○	Signalized Intersection
xx VPH	AM Peak Hour
(xx) VPH	PM Peak Hour

**89-91 NEPEAN STREET**  
**PASS-BY SITE TRAFFIC**  
 OCT 2010 110182 FIGURE 11

### 3.3 Other Planned Developments

A high density residential/commercial development is currently under construction at 187 Metcalfe Street, which is located approximately 75 metres southeast of the subject site. This development shall consist of two 27-storey and one 7-storey condominium towers, a 2,330m<sup>2</sup> grocery store, and a 300m<sup>2</sup> daycare centre. The development is to be constructed in 3 phases, with full completion scheduled for 2013.

NECL produced a combined CTS/Revised TIS in February 2010 in support of a Zoning By-law Amendment application for this development. This study estimated that at full buildout, the development would generate 177 two-way trips in the AM peak hour and 305 two-way trips in the PM peak hour. An excerpt of this report detailing the trip generation of the proposed development, and the distribution of those trips throughout the adjacent road network, is included in this report as Appendix F1.

A high density residential/commercial development is also proposed at 89-91 Nepean Street, which is located immediately south of the subject site. This development shall consist of a 27-storey condominium tower containing 233 units, a 1,200ft<sup>2</sup> commercial unit, and 135 parking spaces on 7 underground levels. The development is to be constructed in a single phase, with full completion scheduled for 2013.

NECL produced a combined CTS/Revised TIS in January 2011 in support of a Zoning By-law Amendment application for this development. This study estimated that at full buildout, the development would generate 74 vehicle trips in the AM peak hour and 75 vehicle trips in the PM peak hour. An excerpt of this report detailing the trip generation of the proposed development, and the distribution of those trips throughout the adjacent road network, is included in this report as Appendix F2.

For the purposes of this study, all trips that will be generated by the 187 Metcalfe and the 89-91 Nepean Street developments are considered to be part of future background traffic. To account for this, the trip distribution volumes shown in Figures 7 and 8 have been included as part of the 2013 and 2018 background traffic volumes that are shown in Figures 9 and 10, respectively.

### 3.4 Trip Generation

Trips generated by the proposed residential dwelling units and commercial floor space have been estimated using relevant peak hour rates identified in the *Institute of Transportation Engineers (ITE) Trip Generation Manual, 8<sup>th</sup> Edition*. The specific land use of the commercial land use is unknown at this time, so it has been conservatively assumed that it will be developed as a convenience market (Mac's or similar). This land use is considered to be one of the most intensive trip generators that could be feasibly contained within the floor space area available. On this basis, the following trip generation calculations are considered to be robust. The trip generation is based on full development as shown in the site plan. The peak hour vehicle trips generated by the proposed development are outlined in the following table.

**Table 2: ITE Trip Generation**

Land Use	ITE Code	Units/GFA	Trip Rates		Vehicle Trips	
			AM Peak	PM Peak	AM Peak	PM Peak
High Rise Residential Condominiums	232	233	Equation <sup>1</sup>	Equation <sup>2</sup>	96 vph	94 vph

1. ITE Trip Equation:  $T = 0.29x + 28.86$ , where  $x$  = number of units

2. ITE Trip Equation:  $T = 0.34x + 15.47$ , where  $x$  = number of units

3. vph = vehicles per hour

Based on the relevant ITE trip rates, the proposed development is expected to generate between 96 vph and 94 vph during peak hours. The trip generation surveys compiled in the *ITE Trip Generation Manual* only record vehicle trips, and the sites surveyed are typically located in suburban locations in the United States where non-auto modes of transportation typically have a modal share of 10% or less. For urban infill developments in downtown locations such as Nepean Street, where multiple modes of transportation are readily available, it is considered good practice to express projected trip generation volumes in terms of person trips, instead of vehicle trips. To convert ITE vehicle trip rates to person trip rates, two adjustment factors have been applied:

- Vehicle occupancy factor: **1.23** (taken from the TRANS 2005 O-D Survey Report)
- Non-auto usage factor: **1.1** (non-auto trips not counted in ITE surveys, assumed 10%)

Combining the two factors gives an overall vehicle trip to person trip adjustment factor of approximately 1.35. Applying this factor to the vehicle trips projected by the ITE rates, the site is expected to generate 130 and 127 person trips during the AM and PM peak hours, respectively.

**Table 3: Person Trips**

Land Use	Vehicle Trips		→	Person Trips	
	AM Peak	PM Peak		AM Peak	PM Peak
High-rise Residential Condominiums	96 pph	94 pph		130 pph	127 pph

The number of car trips that the site will generate has been estimated by categorising the external primary trips and pass-by trips by modal share. The modal shares are based on observed percentages in the *2005 Trans O-D Survey Report* that are specific to the region referred to as the Ottawa Inner Area. The Ottawa Inner Area is close to major centres of retail and employment, has well developed transit facilities, and an extensive sidewalk network. This is reflected in the relatively high observed modal share for non-auto transportation. The modal share values applied to trips generated by the convenience store relate specifically to observed trips that had an origin and destination within the Ottawa Inner Area, as it is considered extremely unlikely that the convenience store will generate a statistically significant volume of trips with an origin or destination beyond the Ottawa Inner Area. The modal shares for trips generated by the residential units relate to all observed trips within the Ottawa Inner Area, including those with an origin or destination beyond that area.

A full breakdown of the projected person trips by modal share and arrival/departure is given in the table below.

**Table 4: Site-Generated Trips by Modal Share**

Travel Mode	Modal Share	AM Peak	PM Peak
Total Person Trips		130 pph 25 in, 105 out	127 pph 79 in, 48 out
Non-Motorized	10%	13 pph 3 in, 10 out	13 pph 8 in, 5 out
Transit	30%	39 pph 7 in, 32 out	38 pph 24 in, 14 out
Car Passenger	10%	13 pph 3 in, 10 out	13 pph 8 in, 5 out
<b>Car Driver</b>	<b>50%</b>	<b>65 vph</b> <b>12 in, 53 out</b>	<b>63 vph</b> <b>39 in, 24 out</b>

The above table shows that the proposed development is expected to generate 65 and 63 vehicle trips in the AM peak and PM peak hour respectively.

### 3.5 Trip Distribution

The distribution of primary trips generated by the development was determined based on the existing traffic patterns and the location of the site access with respect to the adjacent roadway system.

The distribution of primary trips is summarized as follows:

- 35% to/from the north,
- 35% to/from the south,
- 15% to/from the west,
- 15% to/from the east.

The site-generated trip volumes for the weekday AM and PM peak hours are shown in Figure 11. For the purposes of this study, it has been assumed that the vehicle trips generated by the 4 stacked townhouses on Nepean Street will use the proposed access on Gloucester Street.

Total traffic volumes for 2013 and 2018 have been calculated by adding the estimated site generated traffic with the background traffic projections. The 2013 and 2018 total traffic volumes are shown in Figures 12 and 13.

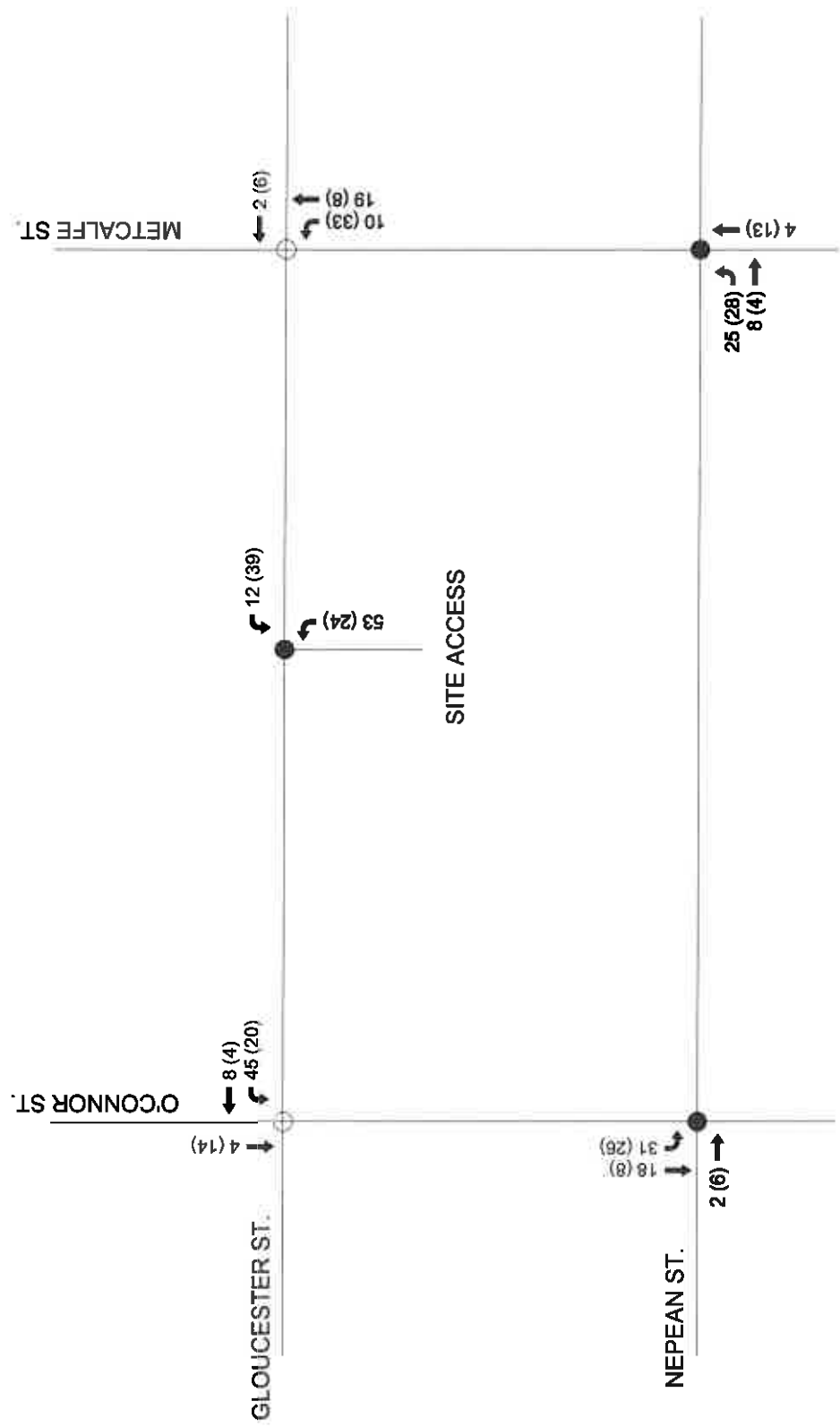

**NOVATECH**  
**ENGINEERING**  
**CONSULTANTS LTD.**  
 ENGINEERS & PLANNERS  
 Suite 200, 24C Michael Cowpland Drive  
 Ottawa, Ontario, Canada  
 K2M 1P5  
 Telephone: (613) 254-5643  
 Facsimile: (613) 254-5867  
 Email: novainfo@novatech-eng.com

**LEGEND**

- Unsignalized Intersection
- Signalized Intersection
- xx VPH AM Peak Hour
- (xx) VPH PM Peak Hour

70 GLOUCESTER STREET

PRIMARY SITE TRAFFIC

FEB 2011 111007 FIGURE 11

## **APPENDIX G**

---

### **City of Ottawa Strategic Screenline System**

City of Ottawa Strategic Screenline System

★ = Subject Site

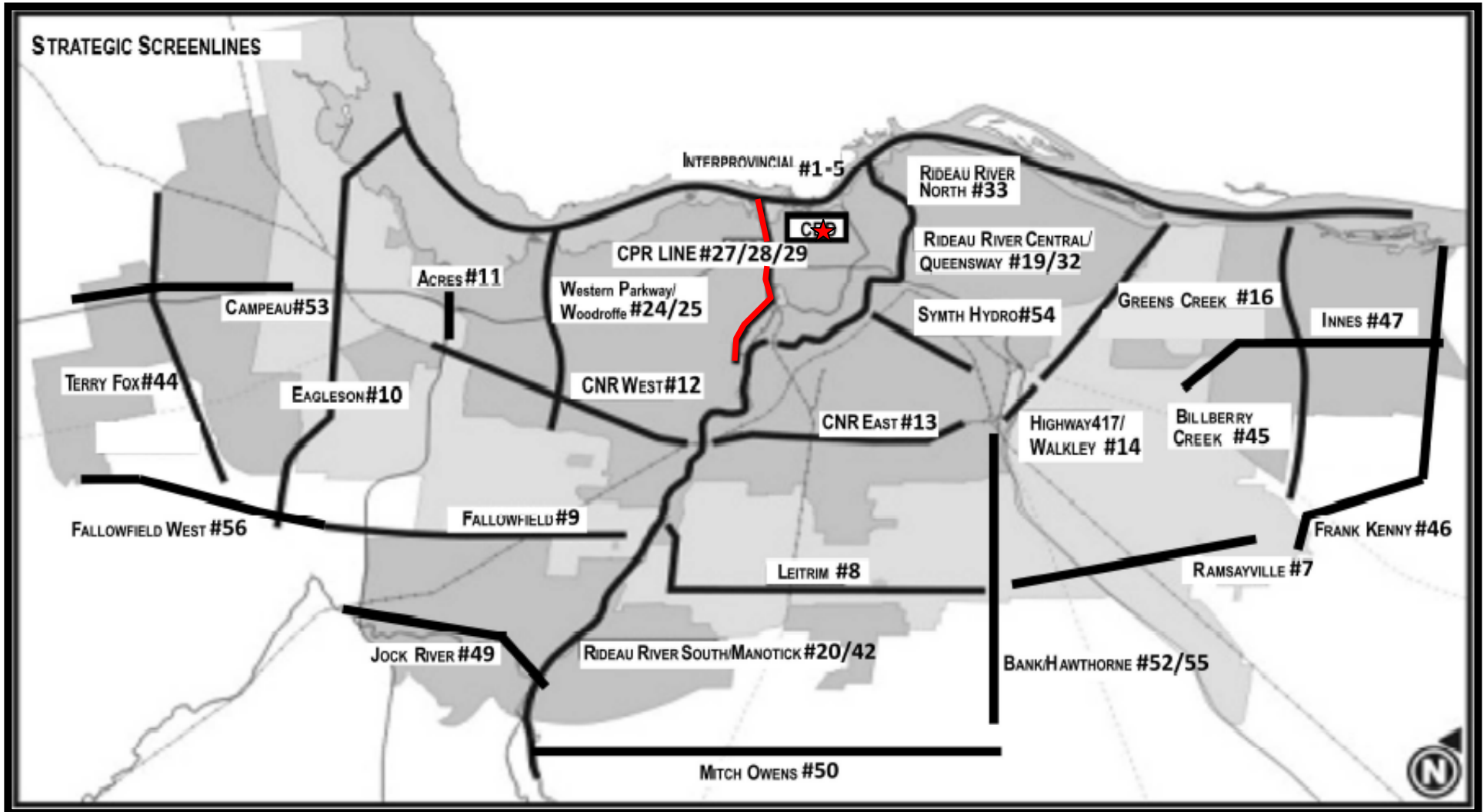

Map taken from *Road Infrastructure Needs Study* (Delcan Corp.)



## APPENDIX H

---

**2008 *Transportation Master Plan* – 2031 Rapid Transit Network**

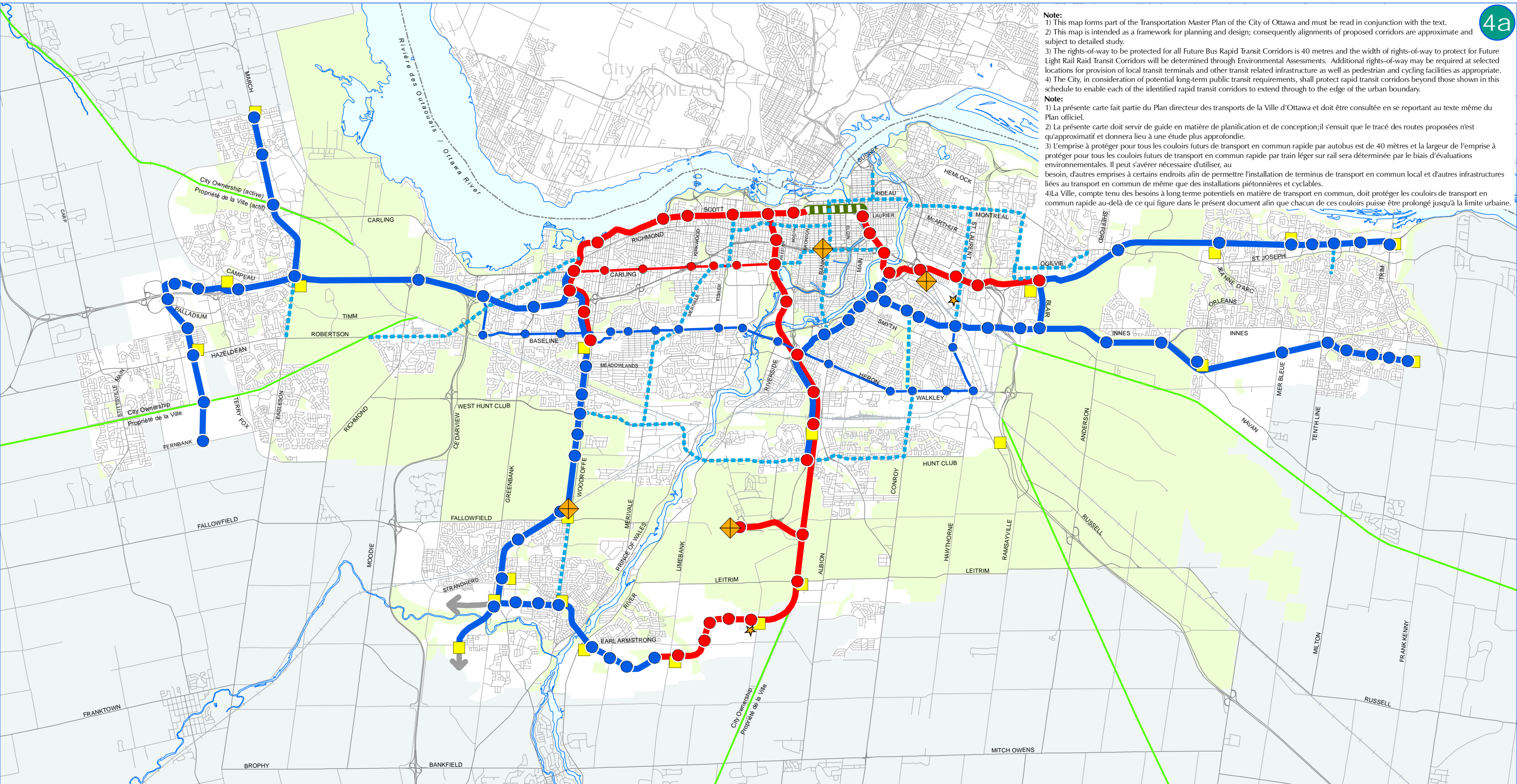

**Note:**  
 1) This map forms part of the Transportation Master Plan of the City of Ottawa and must be read in conjunction with the text.  
 2) This map is intended as a framework for planning and design; consequently alignments of proposed corridors are approximate and subject to detailed study.  
 3) The rights-of-way to be protected for all Future Bus Rapid Transit Corridors is 40 metres and the width of rights-of-way to protect for Future Light Rail Rapid Transit Corridors will be determined through Environmental Assessments. Additional rights-of-way may be required at selected locations for provision of local transit terminals and other transit related infrastructure as well as pedestrian and cycling facilities as appropriate.  
 4) The City, in consideration of potential long-term public transit requirements, shall protect rapid transit corridors beyond those shown in this schedule to enable each of the identified rapid transit corridors to extend through to the edge of the urban boundary.

**Note:**  
 1) La présente carte fait partie du Plan directeur des transports de la Ville d'Ottawa et doit être consultée en se reportant au texte même du Plan officiel.  
 2) La présente carte doit servir de guide en matière de planification et de conception; il s'ensuit que le tracé des routes proposées n'est qu'approximatif et donnera lieu à une étude plus approfondie.  
 3) L'emprise à protéger pour tous les couloirs futurs de transport en commun rapide par autobus est de 40 mètres et la largeur de l'emprise à protéger pour tous les couloirs futurs de transport en commun rapide par train léger sur rail sera déterminée par le biais d'évaluations environnementales. Il peut s'avérer nécessaire d'utiliser, au besoin, d'autres emprises à certains endroits afin de permettre l'installation de terminus de transport en commun local et d'autres infrastructures liées au transport en commun de même que des installations piétonnières et cyclables.  
 4) La Ville, compte tenu des besoins à long terme potentiels en matière de transport en commun, doit protéger les couloirs de transport en commun rapide au-delà de ce qui figure dans le présent document afin que chacun de ces couloirs puisse être prolongé jusqu'à la limite urbaine.

TRANSPORTATION MASTER PLAN - Map 4a  
**RAPID TRANSIT NETWORK - 2031**

PLAN DIRECTEUR DES TRANSPORTS - Carte 4a  
**RÉSEAU DE TRANSPORT EN COMMUN RAPIDE - 2031**

- |                          |   |
|--------------------------|---|
| <b>PRIMARY</b>           | <b>PRINCIPAL</b>                              |
| Light Rail Transit (LRT) | Train léger sur rail (TLR)                    |
| Bus Rapid Transit (BRT)  | Transport en commun rapide par autobus (TCRA) |
| LRT Downtown Tunnel      | TLR Tunnel au centre-ville                    |
| <b>SUPPLEMENTARY</b>     | <b>SUPPLÉMENTAIRE</b>                         |
| Intensive Transit - Bus  | Transport en commun intensif - autobus        |
| Intensive Transit - Rail | Transport en commun intensif - train          |
| Transit Priority         | Transport prioritaire                         |

- |                                    |  |
|------------------------------------|--|
| Park and Ride                      | Parc-O-Bus   |
| Transit Station - rail             | Station du transport - train                       |
| Transit Station - bus              | Station du transport - autobus                     |
| Conceptual Future Transit Corridor | Avenir conceptuel - Couloir de transport en commun |
| Abandoned Railway Corridor         | Emprises ferroviaires abandonnées                  |
| Inter-regional Stations            | Stations interrégionales                           |
| Potential Rail Yard                | Cour de tirage possible pour trains                |