



0	2016/04/11	Site Plan Control
1	2016/10/20	Site Plan Control REV.1

**Apartment Building**

559 Riverdale Avenue  
 Ottawa ON K1S 1M6

title  
**Site Plan & Information**

CITY OF OTTAWA ZONING BY-LAW NO 2008-250				
SECTION	ZONE PROVISION	REQUIRED	PROPOSED	EXCEPTION
161-162 (R4P)	Principal dwelling type	Apartment dwelling, low rise, Stacked	Idem	No
161-162 (R4P)	Minimum Lot Width (m)	15.0	16.7	No
161-162 (R4P)	Minimum Lot Area (m <sup>2</sup> )	450.0	511.0	No
161-162 (R4P)	Maximum Building Height (m)	14.5	13.5	No
161-162 (R4P)	Minimum Front Yard Setback	3.0	3.0	No
161-162 (R4P)	Minimum Rear Yard Setback (m)	Endnote 3: The minimum required rear yard setback is equal to 25% of the lot depth but need not exceed 7.5 metres. Notwithstanding the foregoing, where the rear lot line abuts the interior side lot line of an abutting lot, the minimum required rear yard setback is equal to the minimum required interior side yard setback of the abutting lot along each point of the shared lot line (7.5m in this instance)	6.9	0.6m reduction
161-162 (R4P)	Minimum Interior Side Yard Setback (m)	Endnote 3: For any part of a building located within 21 metres of a front lot line the minimum required interior side yard setback is as follows: (a) Where the building wall is equal to or less than 11m in height: 1.5m; (b) Where the building wall is greater than 11 m in height: 2.5m in all other circumstances the minimum required interior side yard setback is 6m.	1.5m North Interior Side Yard 2.0m South Interior Side Yard	1m on North and 0.5m on South Interior Side Yard within 21 metres of front lot line 4.5 metres on North and 3.5 on South Interior Side Yard beyond 21m (at rear)

GENERAL PROVISIONS				
SECTION	ZONE PROVISION	REQUIRED	PROPOSED	EXCEPTION
100 (6)	General Parking Provisions	All motor vehicle parking spaces, queuing and loading spaces and aisles and driveways leading to those spaces must have a surface which is: (a) hard, stable and dust preventative	Concrete	No
101 (1)	Minimum Parking Spaces Rates	Off-street motor vehicle parking must be provided for any land use at the rate set out in Table 101. In addition, visitor parking must be provided in accordance with Section 102.	Underground parking	No
101(6)		Despite subsection (1), where all parking spaces provided or required for a permitted land use are located below grade in the same building as that land use, the parking required by Table 101 for that land use may be reduced by 10% to a maximum of 20 spaces. (reduction of 1 space permitted)	None	No
Table 101(b) iii (ii)	Residential - Apartment building, low rise	0.5 per dwelling unit = 6 spaces	6	No
Table 102 (a) iii (i)	Minimum visitor parking spaces for Area B on schedule 1 none for first 12 units; 0.2 per dwelling unit for next 300 dwellings;	0 - 12 units: 0 spaces	None	No
106 (1)	Parking space for motor vehicle	2.6m (min) x 5.2m (min)	3 spaces of 2.6x4.6m, 1 space of 2.8x4.6m, 1 space of 2.6x5.2m and 1 space of 2.8x5.2m	3 spaces of 2.6x4.6m and 1 space of 2.8x4.6m
107 (1)(a) / Table 107 f (d)	Aisle and Driveway provisions	A driveway providing access to a parking lot or parking garage must have a minimum width of three metres for a single traffic lane; Angle of Parking = 71-90 degrees / Minimum Required Aisle Width (6.7m).	3.6m for driveway; 6.7m for aisle of parking garage	No
107 (1)(b)ii	Minimum vertical clearance for parking garage	All driveways and aisles providing access to or located within (i) parking garage must have a minimum vertical clearance clear of obstructions such as signs and other structures (i) in accordance with the Building Code, as amended	Minimum 2m as per 3.3.5.4 (5) Repair and storage garages in the Building Code	No
108 (1)(b)	Gradient of Driveway leading into garage	Must not exceed that specified in City of Ottawa Private Approach By-law	12%	No
Table 111A	Bicycle Parking Space for Apartment building, low rise	0.5 spaces per dwelling = 6	6	No
Table 111B	Minimum Bicycle Parking Space Dimensions - horizontal	0.6m (min) x 1.8m (min)	0.6m x 1.8m	No
111 (9)	Minimum Bicycle Access Aisle	1.5m	1.5m	No
137(3)	Amenity Area	Outdoor amenity space area must not be located in a required front or corner side yard	Rear Yard and mezzanine level	No
By-law 2014-189	Minimum Amenity Space Area - Apartment Building, low rise of more than four dwelling units	15m <sup>2</sup> per dwelling unit up to 8 units, plus 6m <sup>2</sup> per unit in excess of 8. A 100% of the amenity area required for the first 8 units is to be: communal, located at grade and in the rear yard be landscaped, consist of at least 80% soft landscaping, and about the rear lot line, unless the lot has access to a rear lane	Communal amenity area 113.5m <sup>2</sup> in the Rear Yard (for the first 8 units) Private amenity area 54.0m <sup>2</sup> on four terraces at the mezzanine level Interior amenity area - NIL	6.5m <sup>2</sup> reduction in the Rear Yard

SITE STATISTICS	
Lot Area	511m <sup>2</sup>
Building Footprint Area	218.3m <sup>2</sup>
Building Footprint % lot	42%
Total Gross Floor Area	1930.3m <sup>2</sup>
Basement G. Floor Area	218.3m <sup>2</sup>
1st level Gross Floor Area	219.6
2nd level Gross Floor Area	243.8m <sup>2</sup>
3rd level Gross Floor Area	243.8m <sup>2</sup>
Mezzanine Level	74.8m <sup>2</sup>
Hard Landscaping	55.6m <sup>2</sup>
Soft Landscaping	148.4m <sup>2</sup>
TOTAL LANDSCAPING	204.0m <sup>2</sup>
Total Landscaping % lot	40%

LEGEND

- Property line
- Setback line
- Surrounding buildings
- Pavers (see Landscape Drawings)
- Concrete (see Landscape Drawings)
- Soft landscaping (see Landscape Drawings)
- Roofing
- Privacy fence offset 0.1m inside property line
- Building overhang / recess line
- Temporary Waste Storage Pad
- Amenity area
- Building access / Egress
- Bench w/ double orientation

ABBREVIATIONS

- FY Min. Front Yard Setback (m)
- RY Min. Rear Yard Setback (m)
- ISY < 21 Interior Side Yard Setback within 21m of front line
- ISY > 21 Interior Side Yard Setback beyond 21m of front line
- ROW Right of way
- AA# Amenity area
- DC Depressed curb 5m radius
- TWSP Temporary Waste Storage Pad

NB: Property boundary information was derived from a Annis O'Sullivan Vollebakk Ltd. field survey, completed December 18th, 2014

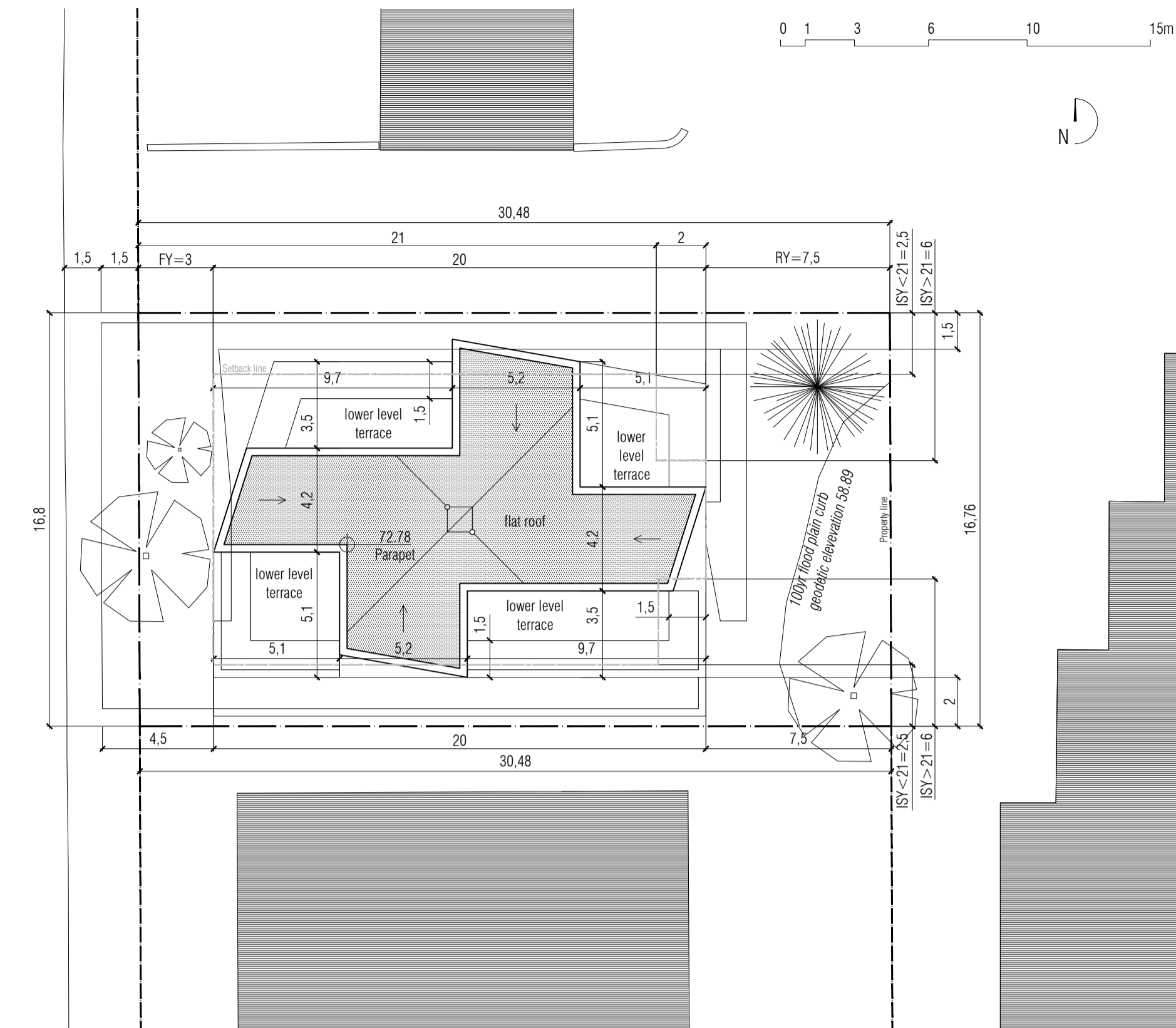

④ Site Plan (rooftop view)  
1:200

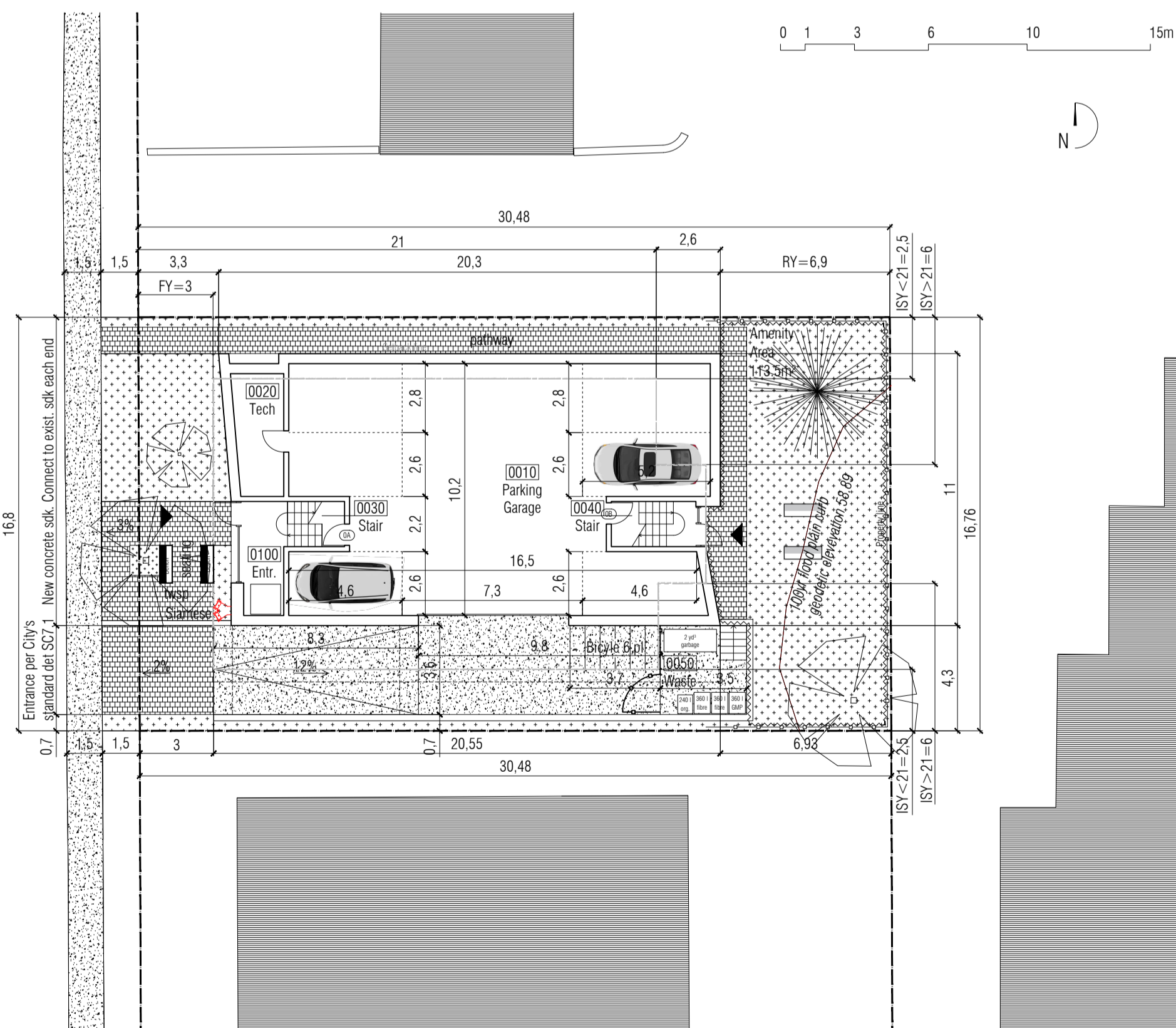

① Site Plan (parking view)  
1:200

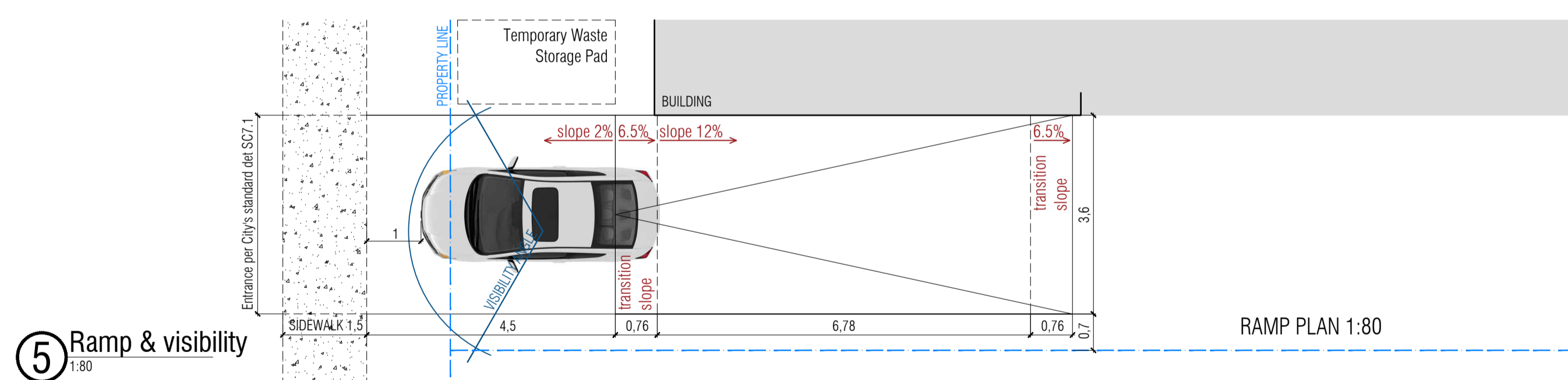
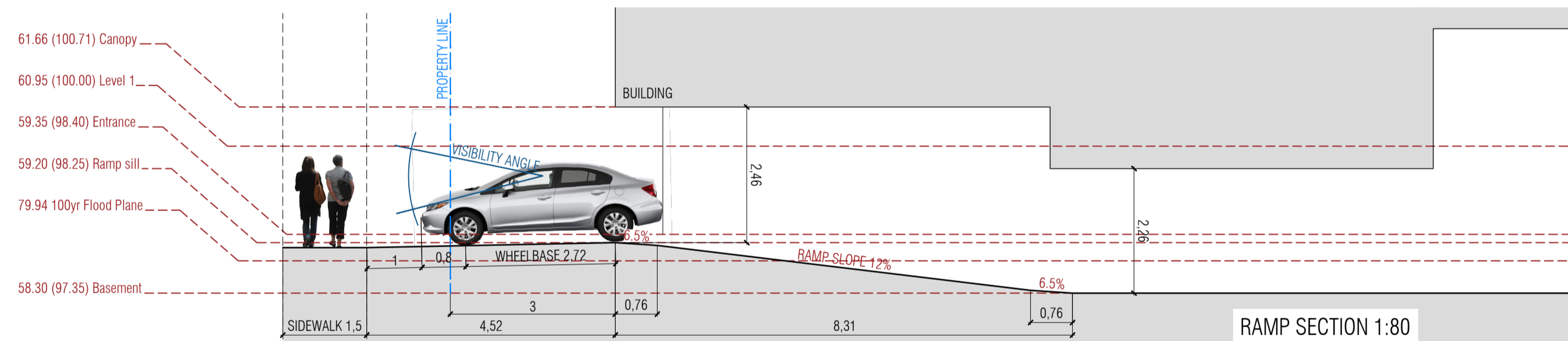

⑤ Ramp & visibility  
1:80

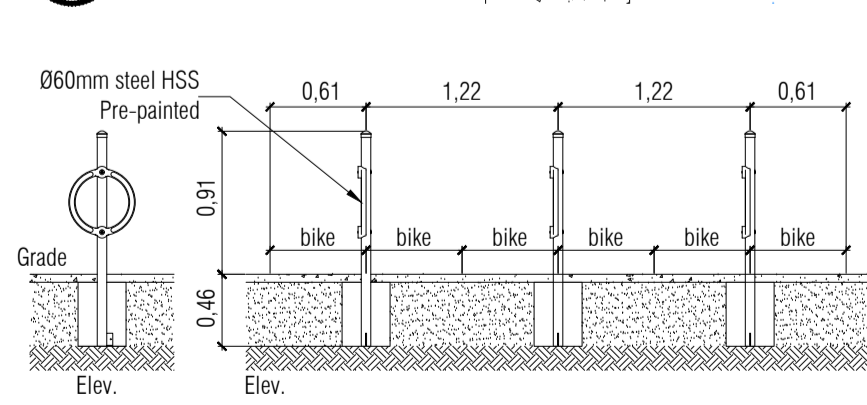

③ Bicycle Rack  
1:50

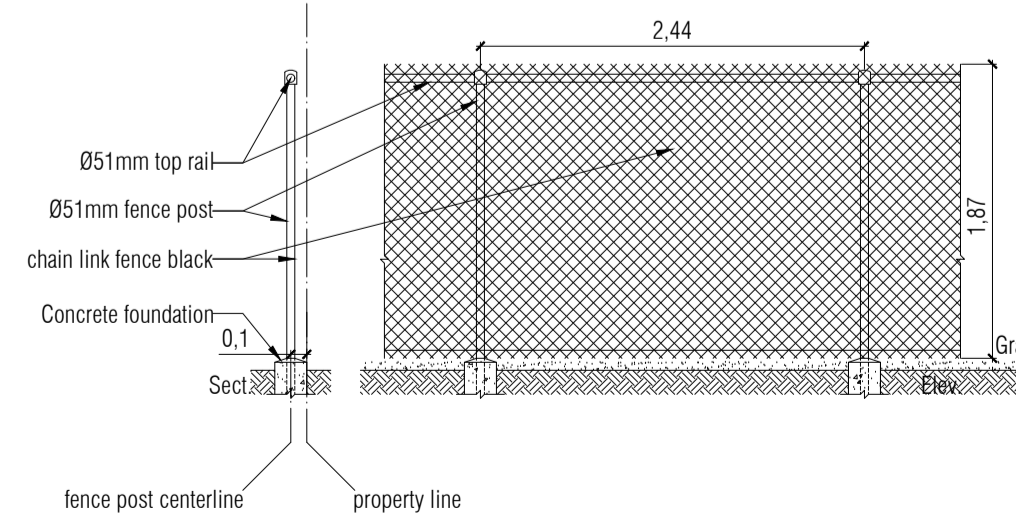

② Chainlink fence  
1:50

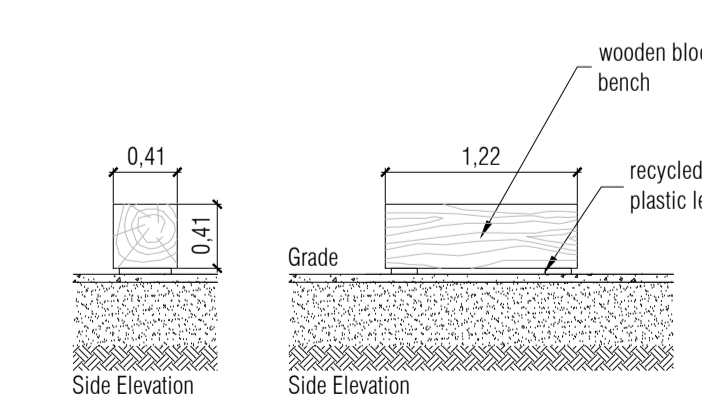

⑥ Double orientation bench  
1:50