



CLIENT : BÂTIMO DÉVELOPPEMENT INC.

PROJECT : LIB ORLÉANS - 500 Famille-Côté Avenue

ÉQUIPE LAURENCE PROJECT NUMBER: 601401

135, boul. de Sainte-Adèle
Sainte-Adèle (Qc)
J8B 0J4

20845, chemin de la Côte Nord
Bureau 204
Boisbriand (Qc) J7E 4H5

474, rue de la Madone
Mont-Laurier (Qc)
J9L 1S5

284, rue Beaudry Nord
Joliette (Qc)
J6E 6A6

117, avenue Lépine
Bureau 202
Gatineau (Qc) J8L 3G1

Le Vieux-Moulin
991, rue Richelieu
Bureau 302
Beloil (Qc) J3G 4P8

T 450 227-1857
info@equipelaurence.ca
equipelaurence.ca

Sainte-Adèle
Boisbriand
Mont-Laurier
Joliette
Gatineau
Beloil

Design report – Stormwater management and serviceability, rev 02

For Site Plan Application

Prepared under supervision by : Valérie Mercier, ing.

Prepared / Verified by : Benoit Bray. Ing. PEO : 100568973



Équipe Laurence inc.

May 2026

EMISSION REGISTER		
#	Date	Emission
A	2025-09-15	For URPD
B	2025-12-09	For Site Plan Application
C	2026-01-29	For Site Plan Application, Rev 01
D	2026-05-20	For Site Plan Application, Rev 02

PROJECT TEAM
L-C. Tellier, tech.
V.Mercier, ing
B.Bray, ing

Table of contents

1	Introduction.....	1
2	Stormwater management	1
2.1	Design criteria for post-developpment flows.....	1
2.2	catch basin sub-areas	2
2.3	Post-developpment: uncontrolled flows.....	3
2.4	Post-development: controlled flows and storage requirements	4
2.5	Stormwater quality.....	5
2.6	Erosion and sediment control	5
3	Sanitary sewer design flows.....	6
3.1	Population density.....	6
3.2	Average wastewater flows and peaking factors	7
3.3	Extraneous flows.....	7
3.4	Total sanitary sewer design flow	7
3.5	SANITArY DOWNSTREAM CAPACITY	7
4	Domestic water demand	8
4.1	Water demands.....	8
4.2	Boundary conditions.....	9
5	Required fire demand	10
6	Références	12

List of appendices

Appendix A – Civil Engineering Plans

Appendix B – Background Documents

Appendix C – Stormwater Flows and Storage Requirements, Detailed Calculations, Storage tank drawing, Quality Control System

Appendix D – Sanitary Sewer Design Flows, Detailed Calculations

Appendix E – Domestic Water Demand, Detailed Calculations, Watermain Pressure

Appendix F – Required Fire Demand, Detailed Calculations

1 INTRODUCTION

This project consists of the residential development located at 500 Famille-Côté Avenue in Ottawa ON. Équipe Laurence Inc. was mandated to carry out the design of the drinking water, storm and sanitary sewer systems that serve the proposed building as well as the stormwater management report. The civil engineering plans depicting the general features of the site, such as the parking areas, sewer structures and landscaping is attached to this report in appendix A.

In this report, the design and calculations of the sanitary sewer, domestic water and stormwater management systems will be discussed. The design was completed in accordance with the following design guidelines and regulations:

- Ottawa Sewer Design Guidelines (2012);
- *Pre-Consultation Preliminary Assessment* written by Kelsey Charie, Infrastructure Project Manager, Development Review- Central. File No. PC2024-0522
- Ottawa Design Guidelines – Water Distribution (2010);
- Ottawa Technical Bulletin ISTB-2018-02 (2018);
- Water Supply for Public Fire Protection, Fire Underwriters Survey (2020).

2 STORMWATER MANAGEMENT

As part of the stormwater management system, the flow of water will be controlled on-site and discharged through a 250 mm diameter service connection. This pipe will be connected to the existing 450 mm diameter storm sewer below De la Famille-Côté Avenue as shown on the attached plans.

According to a complementary land survey completed by *Annis, O'Sullivan, Vollebakk Ltd.* on September 9th, 2025, attached in appendix B, the subject site is primarily occupied by a grassed area.

For the design of the stormwater management system, the calculations were done to ensure that the post-development flows are equivalent to or lesser than the allocated stormwater release rate of 26.1 L/s stated in the *pre-consultation memo*. Hence, the stormwater flows for the developed site as well as the storage requirements will be explored in the following sections.

2.1 DESIGN CRITERIA FOR POST-DEVELOPMENT FLOWS

According to the *pre-consultation memo*, the allowable release rate for the proposed site is 26.1 L/s. Flows in excess the allowable release rate, up to and including the 100-yr storm event, must be retained on site. Hence, these storm events must be considered for the post-development storage requirements calculations.

The post-development storage requirements were determined using the criteria outlined in the *Ottawa Sewer Design Guidelines* as well as the following site information:

- The proposed site area of 0.90 hectares.
- The Rational Method for the calculation of flow as indicated in Section 5.4.4.1 of the design guideline;
- The IDF curves and equations as indicated in Section 5.4.2 of the design guideline;
- The runoff coefficients as shown in Table 5.7 of the design guideline.

In addition, to account for the effects of climate change, a 20% increase will be added to the rainfall intensities of the 100-yr storm event, as per the *Ottawa Sewer Design Guideline*.

2.2 CATCH BASIN SUB-AREAS

The catch basins sub-areas are used to collect the stormwater from its associated area. The areas of impervious and pervious surfaces are determined for each catch basin. The catch basin sub-areas are depicted in Appendix C.

For post-development flow calculations corresponding to the 100-year storm event, a runoff coefficient of 1.00 is applied to roof and concrete surfaces, while a coefficient of 0.313 is used for grassed areas. In accordance with the City of Ottawa *Sewer Design Guidelines*, the 100-year runoff coefficient is determined by increasing the minor system coefficient by 25%.

Using this information, the average runoff coefficient corresponding to a 100-yr storm event is calculated. The results are shown in Table 1 and the detailed calculations are presented in Appendix C.

Table 1: Average Runoff Coefficients for the Various Catch Basin Sub-Areas

Drainage area	Total area (m ²)	Impervious surfaces		Grass surfaces		100-year runoff coefficient
		Area (m ²)	Runoff coefficient	Area (m ²)	Runoff coefficient	
CB-01	296,0	56,6	1,0	239,4	0,313	0,4
CB-02	122,2	122,2	1,0	0,0	0,313	1,0
CB-03	116,9	116,9	1,0	0,0	0,313	1,0
CB-04	1079,6	322,8	1,0	756,8	0,313	0,5
CB-05	1101,8	638,7	1,0	463,1	0,313	0,7
CB-06	623,4	353,0	1,0	270,4	0,313	0,7
MEC-01	457,5	457,5	1,0	0,0	0,313	1,0
MEC-02	522,5	522,5	1,0	0,0	0,313	1,0
UNR	475,0	94,3	1,0	334,6	0,313	0,5
RAMP	135,7	135,7	1,0	0,0	0,313	1,0
DRAIN-TRENCH	517,7	138,4	1,0	379,3	0,313	0,5
ROOF	3456,5	3456,5	1,0	0,0	0,313	1,0
Total	8904,8	6415,1	-	2443,6	-	0,809

* The 100-year runoff coefficients are determined by increasing the 5-year runoff coefficients by 25% as per the city of Ottawa sewer design guidelines.

2.3 POST-DEVELOPPMENT: UNCONTROLLED FLOWS

For the proposed stormwater management system, there is an uncontrolled flow on the corner of the building near Jeanne d'Arc boulevard and Bilberry Drive. The total uncontrolled surface is of 428.8 m², and the calculated time of concentration is of 10 minutes. Therefore, the uncontrolled flows for the 100-year storm events are 11.8 L/s. The detailed calculations are described in the appendix C.

The uncontrolled flow will be subtracted from the allowable release rate for the proposed site to determine the allowable flowrate for the controlled flow as well as the storage requirements.

2.4 POST-DEVELOPMENT: CONTROLLED FLOWS AND STORAGE REQUIREMENTS

The outflow to the storm sewers will be the subtraction of the 100-year uncontrolled flow to the allowable release rate of 26.1L/s, resulting in an allowable controlled flowrate of 14.3 L/s for the whole site. The required storage for the developed site was calculated using the Rational Method. According to the Ottawa Sewer Design Guidelines, the City of Ottawa requires an average release rate equal to 50% of the peak allowable rate to estimate the necessary storage volume.

Water collected from the roof drains will be conveyed to an underground concrete tank equipped with an inlet control device (ICD) located at the outlet, regulating the discharge to a maximum flow rate of 4.0 L/s. Therefore, the roof subcatchment has a retention requirement of 291.3 m³. A portion of this volume will be retained on the roof, while the remainder will be stored in the tank.

Runoff of the remaining of the site will be directed through the storm sewer structures and pipes, to a second underground concrete tank, also equipped with an inlet control device (ICD), which will control a maximum flowrate of 3.1 L/s. The corresponding site subcatchment requires a storage volume of 345 m³.

The combined regulated outflow from both systems is 7.1 L/s (4.0 + 3.1 L/s), which represents 50% of the allowable controlled flow rate of 14.3 L/s for the entire site. The storage volume provided by both subcatchments represents the total required retention requirement including the 20% increase for the climate change as required by the city and using the average release rate and a 10% increase to the volume as a safety factor. The detailed calculations are found in Appendix C.

Furthermore, an overflow pipe will be incorporated into both retention tanks with an invert at the water retention elevation, preventing flooding if a blockage or malfunction occurs. The proposed stormwater storage distribution is shown in Table 1.

Table 2 - Proposed Stormwater Storage – 500 Famille-Côté Avenue

Parameters	Values	Units
100-year required storage of the project ^{1,2}	636.3	m ³
Volume retained in storm pipes and structures	10	m ³
Volume retained on the roof (to be validated by mechanical ing)	138.3	m ³
Volume retained in underground concrete tank #1 (from roof drainage)	153	m ³
Volume retained in underground concrete tank #2 (from surface water)	345	m ³
Total storage volume available	646.3	m³

1 - A 10% increase was included in the volume requirement as an extra safety measure

2 - A 20% increase to rainfall was included for the climate change effects

The following items related to rooftop drainage will need to be completed by the mechanical and structural engineer responsible for the design:

- Flow Control Roof Drainage Declaration;
- Design of the underground concrete tank. See appendix C.

The proposed Inlet control devices (ICD) are both a vortex flow regulator model 50 VHV-1 by the company John Meunier. The water head is 1.6 m, see Appendix C. The ICD will have an overflow, see plans for more details.

2.5 STORMWATER QUALITY

Stormwater quality control is mandatory for all sites. As mentioned in the *pre-consultation memo*, the site must reach 80% Total Suspended Solids (TSS) removal prior to discharge into the storm sewer. Low Impact Development (LID) Best Management Practices (BMPs) should be used wherever possible as part of the proposed development. LID measures such as bioretention, permeable pavement, tree conservation and green roofs are intended to address water quality and quantity concerns. Many of these measures can't be provided for this project due to development requirements and site constraints.

Thus, to meet this requirement, a stormwater quality control system capable of 80% TSS removal, as per the Jellyfish Filter JF4-2-1 from Imbrium Systems Inc., will be installed upstream of the connection point between the proposed storm network and the existing storm sewer. See Appendix C for details and unit specifications.

2.6 EROSION AND SEDIMENT CONTROL

Prior to, during and after construction, the following erosion and sediment control measures should be implemented to avoid the sediment transfer to existing streams and storm sewer systems.

Pre-Construction

- Installation of a silt fence (geotextile)
- Installation of inserts inside all existing manholes adjacent to construction zone
- Control measures to be inspected once installed
- Installation of a mud mat at the site access point

Construction

- Minimize the extent of disturbed areas
- Protect disturbed areas of runoff
- Provide cover if disturbed areas will not be reinstated within a reasonable period.
- Inspect silt fence regularly during construction. Clean and repair, as required.
- Control dust during construction

After Construction

- Provide permanent cover to disturbed areas (i.e. topsoil and seed)
- Remove all temporary erosion and sediment control items (silt fence and filter cloths) once disturbed areas have been reinstated

Inspections

- Erosion and sediment control measures will be inspected upon completion
- Control measures are to be inspected weekly

All control measures are to be inspected once installed as well as during construction.

3 SANITARY SEWER DESIGN FLOWS

The proposed sanitary sewer service connection for the new building is 250 mm in diameter and made of PVC. The pipe will be connected on the existing 250 mm diameter municipal sewer pipe under De La Famille-Côté Avenue, via a new manhole.

The proposed sanitary system is designed in accordance with the *Ottawa Sewer Design Guidelines*. The calculations for the proposed development flows are shown in the following sections.

3.1 POPULATION DENSITY

The population density of the proposed development is calculated using the number and type of housing units within this development. The detailed calculations are shown in table below and in the appendix D.

Table 3 – Population Density Calculation

Unit Types	Number of Units	Persons Per Unit	Population Density
1-bedroom	196	1.4	274
2-bedroom	158	2.1	332
Total =			606

Using the values in Table 4.2 of the *Ottawa Sewer Design Guidelines* for per unit populations, the population densities of the proposed development are found to be 606 persons. This value will be used in the following sections to determine the sewer design flows.

3.2 AVERAGE WASTEWATER FLOWS AND PEAKING FACTORS

The average wastewater flow for residential developments of 280 L/c/d is used to determine the average day demand for residential use. The new building will not include commercial areas. Using this information, the total average wastewater flow for the proposed development is calculated below.

Average wastewater flow per capita for residential use: 280 L/c/d

Average wastewater flow for residential use: 169 736 L/d

The Harmon equation is then used to calculate the residential peak factor.

$$P.F. = 1 + \left(\frac{14}{4 + \left(\frac{P}{1000} \right)^{1/2}} \right) \times K, \quad \text{where } K = 1$$

Hence, the peak factor for residential use is of 3.93.

3.3 EXTRANEIOUS FLOWS

In accordance with Article 4.4.1.4 of the *Ottawa Sewer Design Guidelines*, an allowance for flows from extraneous sources must be considered in the calculation of the peak design flow.

The average infiltration allowance is of 0.28 L/s/gross ha for wet-weather inflow into the manholes and pipes. Therefore, with a total site area of 0.90 ha, the infiltration flow is 0.25 L/s.

3.4 TOTAL SANITARY SEWER DESIGN FLOW

Combining the results from the above calculations, the total sanitary sewer design flow is calculated as follows:

$$Q_{design} = [(3.93 \times 169\,736\text{ L/d})] \times \frac{1}{86\,400\text{ sec/d}} + 0.25\text{ L/s}$$

$$Q_{design} = 7.97\text{ L/s}$$

The summary of this calculation is shown in appendix D.

3.5 SANITARY DOWNSTREAM CAPACITY

As per the pre-consultation memo, the original subdivision servicing report allocated a sanitary peak design flow of 5,18 L/s for this site, corresponding to approximately to 302 persons or 168 residential units. It was also noted

that, following the 2018 update to the City of Ottawa Sewer Design guidelines, the same peak design flow of 5.18 L/s would instead correspond to approximately 440 persons or 244 residential units for this property.

An assessment of the available capacity in the existing municipal downstream sanitary sewers was subsequently prepared by *Novatech – Engineers, Planners & Landscape Architects* (January 21, 2025). This analysis indicates that the 2018 update to the Sewer Design Guidelines reduced the unit sanitary flow rate from 350 L/p/s to 280 L/p/s to better reflect real-world change. This adjustment resulted in a reduction in calculated design flows for both existing and proposed developments, thereby increasing the residual capacity within the sewer system.

Based on this revised capacity assessment, the permissible development density for the subject site was increased to approximately 400 residential units, corresponding to a peak design flow of 8.1 L/s. Thus, proposed development, consisting of 354 units with a total sanitary peak design flow of 7.97 L/s, remains within the available municipal sewer capacity of 8.1 L/s.

The full capacity assessment is provided in appendix D.

4 DOMESTIC WATER DEMAND

The proposed water service connection for the new building will consist of two separate branch connections, both on De la Famille-Côté Avenue. Each connection will be 150 mm in diameter and made of PVC. Both connections will be connected to the existing 203 mm diameter municipal watermain on De la Famille-Côté Avenue. Two shutoff valves will be installed at the property line for each connection as per the City guidelines. Additionally, both connections will be looped at the service entry inside the building, and an isolation valve will be placed between the two water service connections. Isolation valves allow the shutdown of specific sections of the water pipeline during repairs, maintenance or emergencies, without disturbing the entire flow system.

The proposed water system is designed in accordance with the *Ottawa Design Guidelines – Water Distribution*. The calculations for the proposed water demand are shown in the following sections.

4.1 WATER DEMANDS

We can determine the average day demand for the proposed development using the values found in Table 4.2 of the *Ottawa Design Guidelines – Water Distribution* as the population density of the development was determined to be 607 people. Hence, an average day demand of 280 L/c/d is used for the residential spaces.

Average day demand per capita for residential use: 280 L/c/d

Average day demand for residential use: 169 736 L/d

Therefore, the total average day demand is:

$$Q_{avg,day} = \left(169\,736 \frac{L}{d}\right) \times \frac{1}{86,400} \text{sec}/d = 1.96 \text{ L/s}$$

The maximum daily demand and the maximum hour demand are calculated using the factors found in Table 4.2 of the *Ottawa Design Guidelines – Water Distribution*.

$$Q_{max,day} = \left(2.5 \times 169\,736 \frac{L}{d}\right) \times \frac{1}{86,400} \text{sec}/d = 4.91 \text{ L/s}$$

$$Q_{max,hr} = \left(2.2 \times 2.5 \times 169\,736 \frac{L}{d}\right) \times \frac{1}{86,400} \text{sec}/d = 10.80 \text{ L/s}$$

The detailed calculations for domestic water demand are found in appendix E.

4.2 BOUNDARY CONDITIONS

This section presents the existing boundary conditions for the water distribution system for the connection sites. Note, this information is based on current operation of the city's water distribution system. The results from the City of Ottawa are provided in the appendix E.



Figure 1 : Service connection location for the water distribution system (City of Ottawa)

Table 4 : Connection on Albert Street (City of Ottawa)

Demand Scenario	Head (m)
Maximum HGL	115.1
Minimum HGL	107.7
Max Day + Fire Demand (88.2 L/s)	107.7

The pressure at the service points on La Famille-Côté Avenue has been calculated, with detailed calculations provided in Appendix E of this report.

It must be noted that the static pressure at any fixture shall not exceed 552 kPa (80 psi) according to the Ontario Building Code for areas that may be occupied. Hence, the following pressure control measures shall be considered:

1. If possible, the systems are to be designed to residual pressures 345 to 552 kPa (50 to 80 psi) for all occupied areas outside of the public right-of-way without special pressure control equipment.
2. Pressure reducing valves are to be installed immediately downstream of the isolation valve in the building, located downstream of the meter so that it is maintained by the owner.

These pressure control measures are presented in order of preference.

5 REQUIRED FIRE DEMAND

The flow rates required for fire protection vary according to the zoning, the type of units, the fire resistivity of the construction materials, the ground floor area as well as many other factors. The method described in *Water Supply for Public Fire Protection*, written by the Fire Underwriters Survey (FUS) (2020) is used to estimate the fire demand required for fire protection, as per the City Guidelines.

Essentially, the required flow rate (F), expressed in liters per minute, is calculated based on the floor area of the building (A) in square meters and the type of construction (C), using the following equation.

$$F = 220 \times C\sqrt{A}$$

The value of C used is 0.8 for a non-combustible construction. According to the FUS, a non-combustible construction is "any structure having all structural members including walls, columns, piers, beams, girders, trusses, floors and roofs made of non-combustible material and not qualifying as fire-resistive construction." In this case, the building will be full non-combustible construction both for the construction type and exterior cladding.

The value of A represents the gross floor area of the building, that is, the sum of the surface area of all floors. See in the table below that surface area of each floor. The effective area is to be calculated as per the 2020 regulations for the *Water Supply for Public Fire Protection in Canada*, the total effective area is to be calculated as the largest floor with the addition of 25% of the next 2 adjacent floors.

Table 5 – Gross Floor Area for the Proposed Development

Floor	Surface Area Per Floor (m ²)	Number of Floors	Floor Area (m ²)
Ground Floor	3 301	1	3 301
Level 2	3 105	1	3 105
Level 3	3 106	1	3 106
Level 4	3 104	1	3 104
Level 5	1 960	1	1 960
Levels 6-12	2 045	7	14 315
Levels 13-14	1 153	2	2 306
Total =			31 197

Finally, according to the FUS method, certain reductions and increases may be applied depending on a variety of factors such as the combustibility of the occupying materials or furniture, the presence of automatic sprinklers systems as well as the development's distance from neighbouring buildings. For example, for buildings protected by automatic sprinklers designed in accordance with the NPFA 13, the flow rate required for fire protection, F, can be reduced by 50%.

Using this method, the total fire demand was determined to be 5000 L/min. Moreover, for a duration of water supply of 2 hours, the required volume of water is 600 m³. The details of the fire flow calculations are shown in the appendix F.

6 RÉFÉRENCES

CITY OF OTTAWA. *Ottawa Design Guidelines – Water Distribution*, 2010.

CITY OF OTTAWA. *Ottawa Sewer Design Guidelines*, 2012.

CITY OF OTTAWA. *Technical Bulletin ISTB-2018-02*, 2018.

FIRE UNDERWRITERS SURVEY, *Water Supply for Public Fire Protection*, 2020.

Appendix A – Civil Engineering Plans

Appendix B – Background Documents

Land Survey by Annis, O'Sullivan, Vollebakk Ltd. on September 9th, 2025

Appendix C – Stormwater Flows and Storage Requirements, Detailed Calculations, Storage tank drawing, Quality Control System

STORMWATER CALCULATIONS

IDF CURVES FOR THE CITY OF OTTAWA

IDF curve equations (Intensity in mm/hr)

100 year Intensity	= 1735.688 / (Time in min + 6.014) ^{0.820}
50 year Intensity	= 1569.580 / (Time in min + 6.014) ^{0.820}
25 year Intensity	= 1402.884 / (Time in min + 6.018) ^{0.819}
10 year Intensity	= 1174.184 / (Time in min + 6.014) ^{0.816}
5 year Intensity	= 998.071 / (Time in min + 6.053) ^{0.814}
2 year Intensity	= 732.951 / (Time in min + 6.199) ^{0.810}

WATERSHED

The watersheds of the project are as displayed in the drawing below. The orange zone represent the area that is considered as uncontrolled flow as the water will leave the site without control, and the blue, red and pink zones represent the areas where the runoff is controlled before being directed into the municipal sewer system.

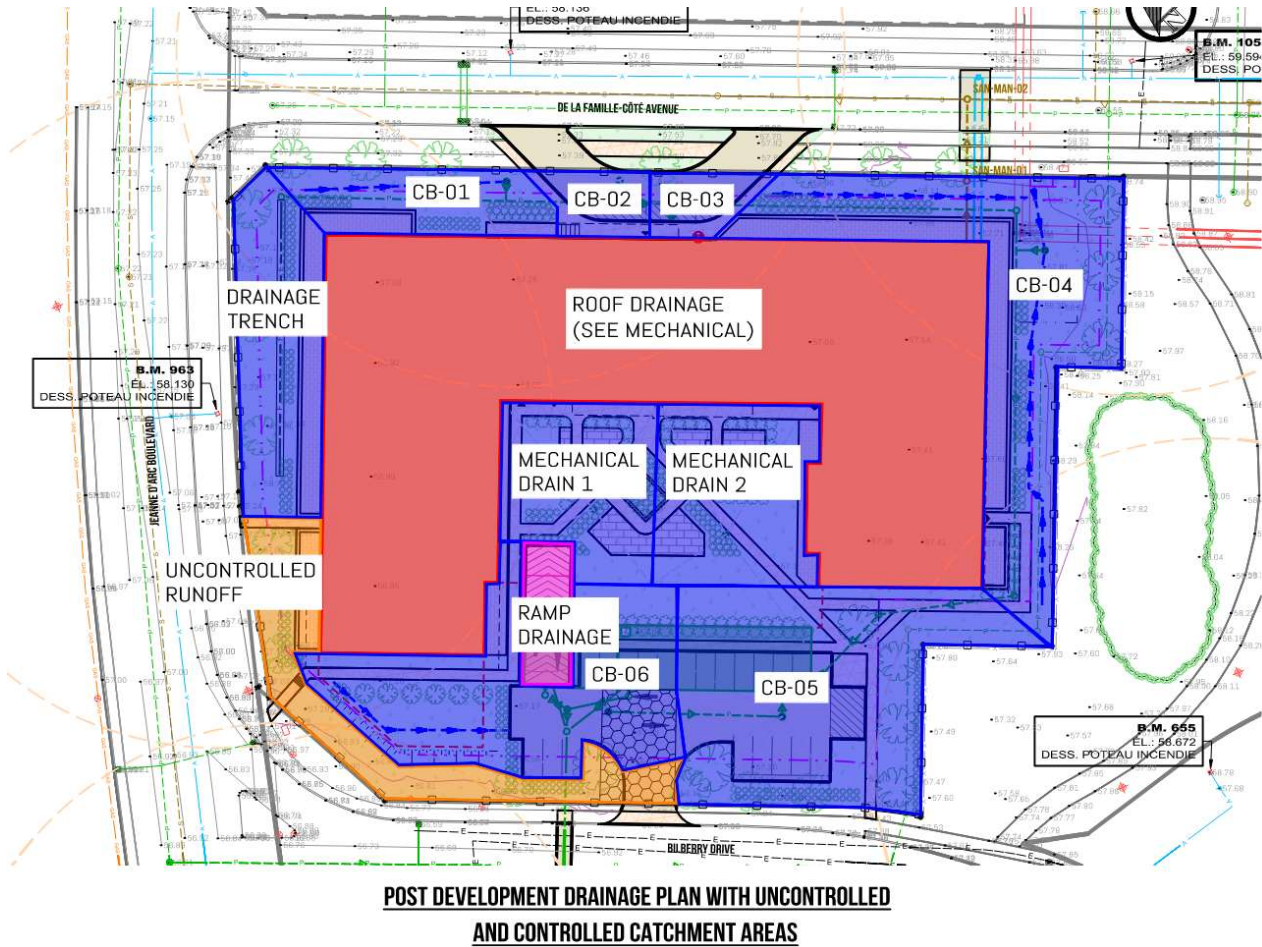

HYPOTHESE

- The roof is a part of the drainage areas draining downstream of on of the underground tanks.

Here are the calculations for the post-development flowrate as asked by the city.

TABLE 1 – PROPOSED POST-DEVELOPMENT CATCHMENT AREAS

Drainage area	Total area (m ²)	Impervious surfaces		Grass surfaces		100-year runoff coefficient
		Area (m ²)	Runoff coefficient	Area (m ²)	Runoff coefficient	
CB-01	296,0	56,6	1,0	239,4	0,313	0,4
CB-02	122,2	122,2	1,0	0,0	0,313	1,0
CB-03	116,9	116,9	1,0	0,0	0,313	1,0
CB-04	1079,6	322,8	1,0	756,8	0,313	0,5
CB-05	1101,8	638,7	1,0	463,1	0,313	0,7
CB-06	623,4	353,0	1,0	270,4	0,313	0,7
MEC-01	457,5	457,5	1,0	0,0	0,313	1,0
MEC-02	522,5	522,5	1,0	0,0	0,313	1,0
UNR	475,0	94,3	1,0	334,6	0,313	0,5
RAMP	135,7	135,7	1,0	0,0	0,313	1,0
DRAIN-TRENCH	517,7	138,4	1,0	379,3	0,313	0,5
ROOF	3456,5	3456,5	1,0	0,0	0,313	1,0
Total	8904,8	6415,1	-	2443,6	-	0,809

RUNOFF COEFFICIENT CALCULATION

$$C = \frac{\sum(A_i \times C_i)}{\sum A}$$

Where A_i is the Area of a certain material type

C_i is the runoff coefficient of a certain material type

Example:

$$C_{CB-04} = \frac{698 \times 0.900 + 186 \times 0.250}{698 + 186} = 0.763$$

TABLE 2 - PROPOSED UNCONTROLLED FLOW

Parameters	Values	Units
Impervious surfaces	94.3	m ²
Grass surfaces	334.6	m ²
Total area	428.8	m ²
100-year Runoff coefficient	0.46	-
Time of concentration	10	min
Uncontrolled 100-year flow	11.8	ℓ/s

* The 100-year runoff coefficients are determined by increasing the 2-year runoff coefficients by 25% as per the city of Ottawa sewer design guidelines.

TABLE 3 - PROPOSED CONTROLLED FLOW

Parameters	Values	Units
Allowable release rate / total flow	26.1	ℓ/s
100-year uncontrolled flow	11.8	ℓ/s
Allowable release rate / Controlled flow	14.3	ℓ/s
Release rate controlled by ICD 1 (50% of allowable flow)	4.0	ℓ/s
Release rate controlled by ICD 2 (50% of allowable flow)	3.1	ℓ/s
100-year storage requirement *	636.2	m ³

*Storage requirement calculations includes a 20% increase in rainfall

*Storage requirement calculations includes a 10% increase in volume

TABLE 4 - PROPOSED STORMWATER STORAGE

Parameters	Values	Units
100-year required storage of the project ^{1,2}	636.2	m ³
Volume retained in storm pipes and structures	10	m ³
Volume retained on the roof (to be validated by mechanical ing)	138.3	m ³
Volume retained in underground concrete tank #1 (from roof drainage)	153	m ³
Volume retained in underground concrete tank #2 (from surface water)	345	m ³
Total storage volume available	646.3	m³

1 - A 10% increase was included in the volume requirement as an extra safety measure

2 - A 20% increase to rainfall was included for the climate change effects

TABLE 5 – INLET CONTROL DEVICE (ICD)

Zone	Pipe	Flowrate (L/s)	Water level	Invert (m)	Water head (m)	Type *
ST-MH-01	300 mm PVC	4.0	56.5	54.9	1.6	Vortex 50 VHV-1 from Veolia or equivalent approved
ST-MH-02	300 mm PVC	3.1	56.5	54.9	1.6	Vortex 50 VHV-1 from Veolia or equivalent approved

*The type of ICD and specifications has to be validated with the manufacturer and mechanical engineer

INFORMATION GÉNÉRALE

Application	Eau Pluviale	
Nom du projet	Orléans	
Numéro de projet	601401	
Commentaire		
Identification	ST-MH-01	
Débit de conception (Q)	4	L/s
Charge d'eau de conception (h)	1.6	m
Diamètre de la conduite de sortie (C)	300	mm
Type de conduite	PVC	
Modèle	50 VHV-1,12,OF	
Item #	PRIPHY200266	
Quantité	1	
Dégagement minimum (H)	150	mm
Diamètre minimum du regard (B)	600	mm

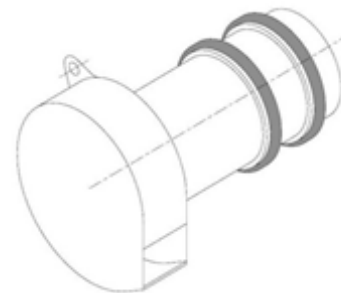

COURBE DE DÉBIT

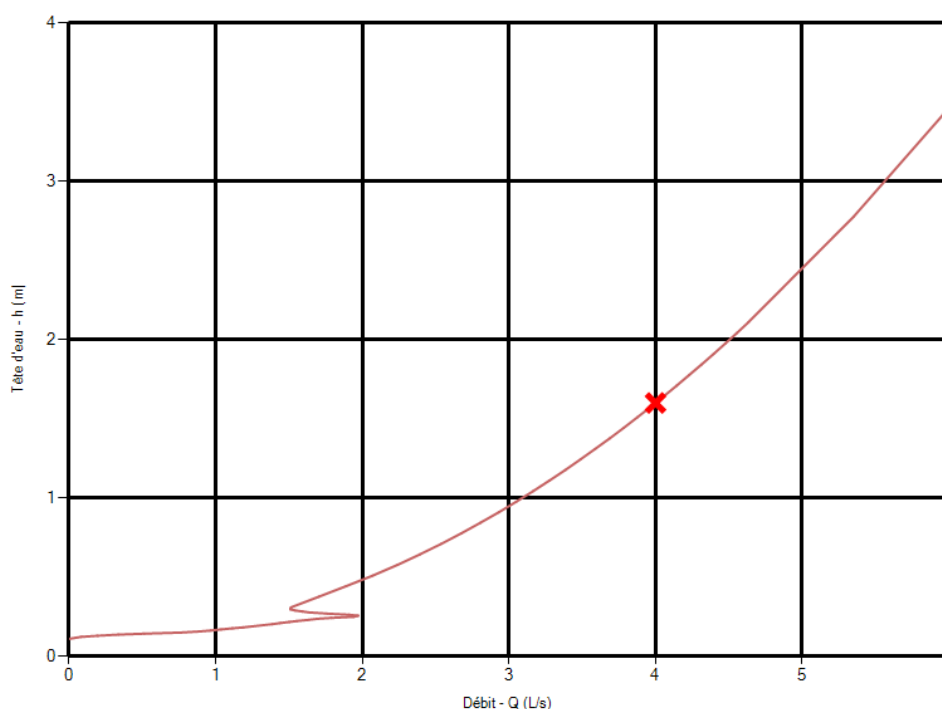

Q (L/s)	h (m)
0.000	0.109
0.514	0.142
1.115	0.176
1.441	0.209
1.790	0.242
1.642	0.276
1.516	0.309
2.392	0.643
3.050	0.976
3.589	1.310
4.057	1.643
4.477	1.977
6.553	4.111
8.459	6.779

INSTALLATION TYPIQUE

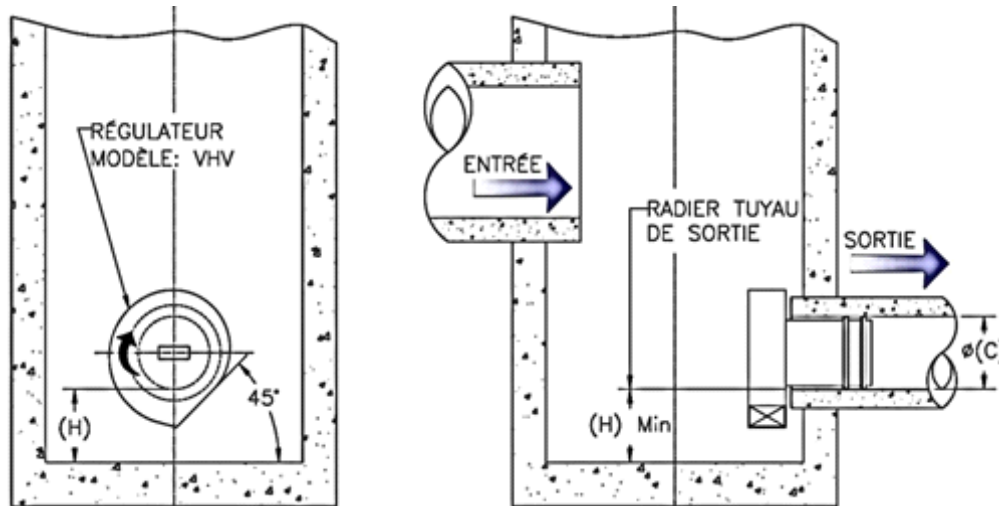

SPÉCIFICATIONS

Le régulateur de débit sera du type statique utilisant le principe du vortex et n'aura aucune partie mobile. Le débit sera régularisé sur toute la charge en utilisant uniquement les propriétés hydrauliques de l'unité. Le régulateur sera auto activé et ne nécessitera pas d'instrumentation ou alimentation externe.

Chaque régulateur de débit est constitué d'un corps à l'intérieur duquel s'effectue le contrôle de débit. Un manchon est soudé au corps pour permettre son insertion convenable à l'intérieur du tuyau de sortie du regard. Deux joints toriques en caoutchouc assurent l'étanchéité et le maintien du manchon dans le tuyau. Deux barres soudées au manchon empêchent les joints toriques de se déplacer durant l'installation et le fonctionnement.

Le régulateur sera construit entièrement à partir d'acier inoxydable 304 avec soudures continues, tel que fabriqué par Veolia Water Technologies Canada Inc. (John Meunier), 514-334-7230, cso@veolia.com.

Nom du projet: Orléans
 Numéro de projet: 601401
 Identification: ST-MH-01
 Débit (Q): 4 L/s
 Charge d'eau (h): 1.6 m
 Modèle: 50 VHV-1,12,OF
 # item: PRIPHY200266
 Quantité: 1

Dimensions (mm)	
A	50
B	42
L1	182
L2	164
L	200
DS	275
O1	38
O2	100
Ø ÉVENT	N/A

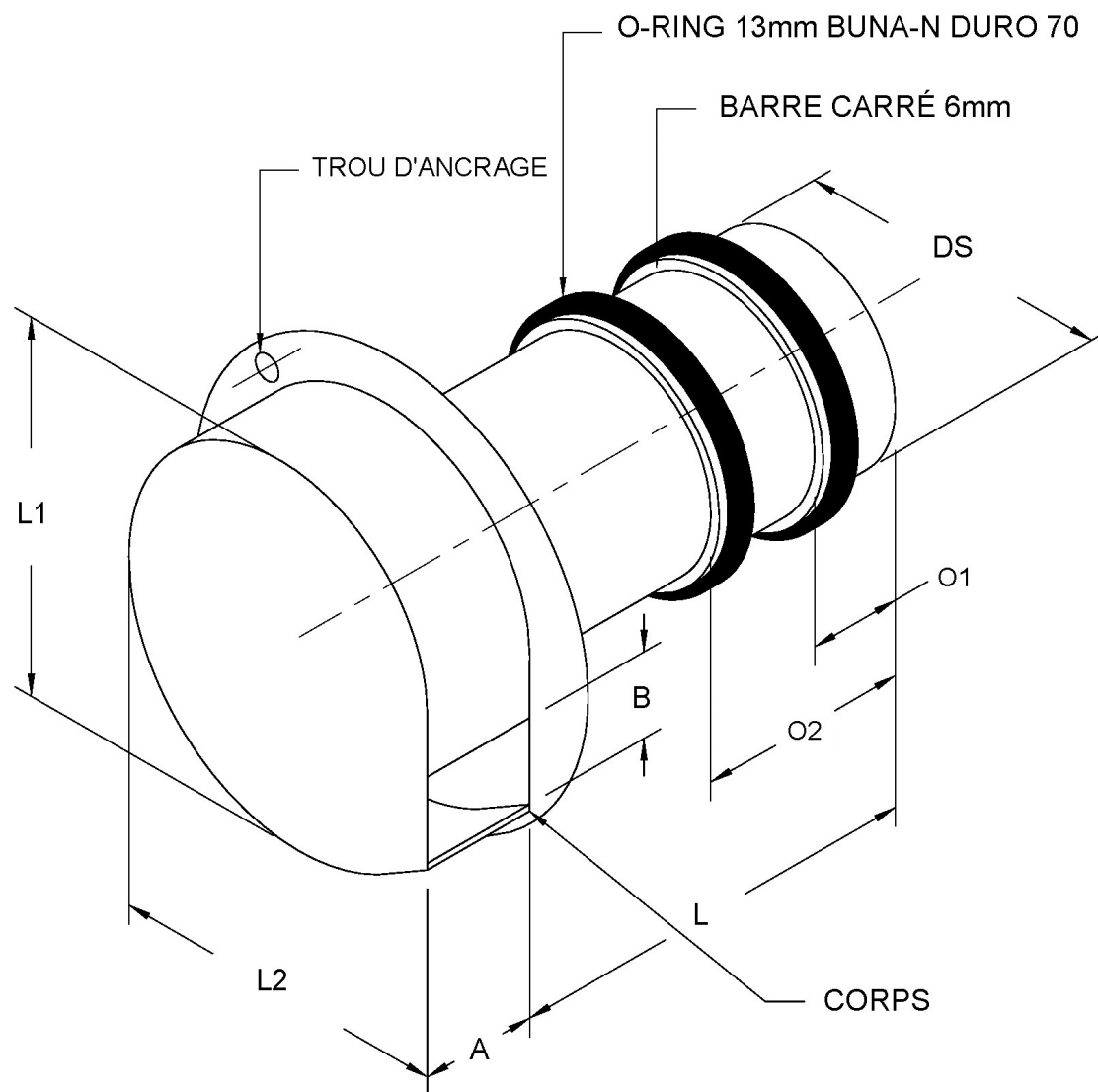

Toutes les dimensions sont en millimètres à moins avis du contraire

INFORMATION GÉNÉRALE

Application	Eau Pluviale	
Nom du projet	Orléans	
Numéro de projet	601401	
Commentaire		
Identification	ST-MH-01	
Débit de conception (Q)	3.1	L/s
Charge d'eau de conception (h)	1.6	m
Diamètre de la conduite de sortie (C)	300	mm
Type de conduite	PVC	
Modèle	50 VHV-1,12,OF	
Item #	PRIPHY200266	
Quantité	1	
Dégagement minimum (H)	150	mm
Diamètre minimum du regard (B)	600	mm

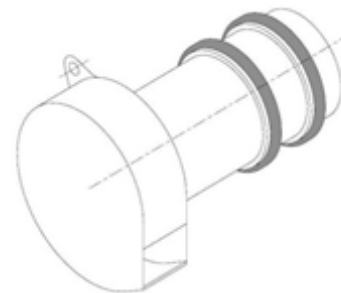

COURBE DE DÉBIT

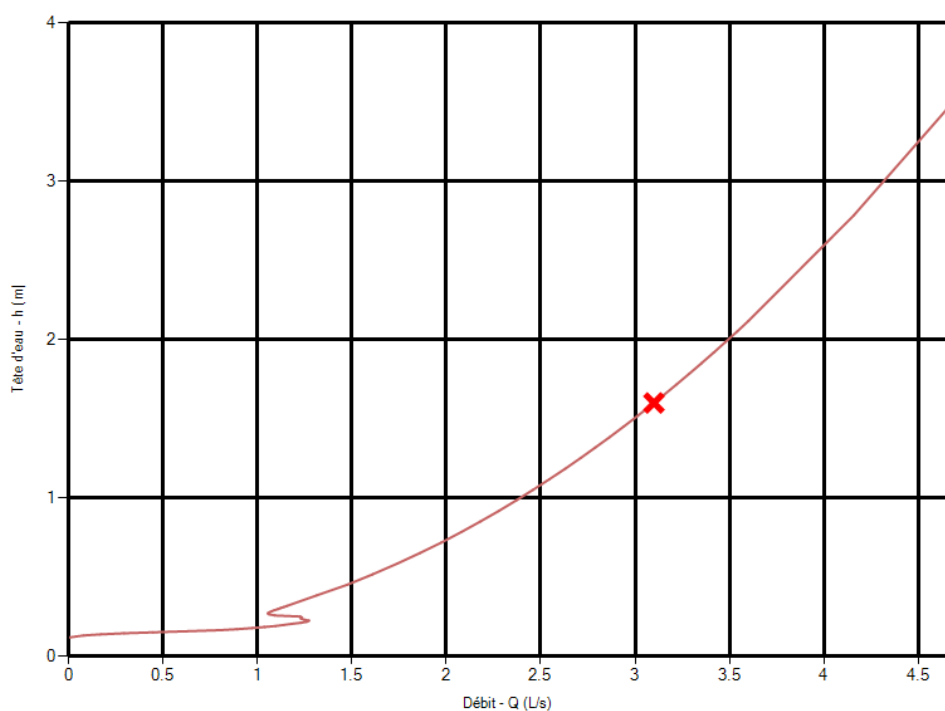

Q (L/s)	h (m)
0.000	0.117
0.446	0.150
1.037	0.184
1.260	0.217
1.225	0.250
1.076	0.284
1.155	0.317
1.860	0.651
2.370	0.984
2.789	1.318
3.153	1.651
3.479	1.985
5.093	4.119
6.574	6.787

INSTALLATION TYPIQUE

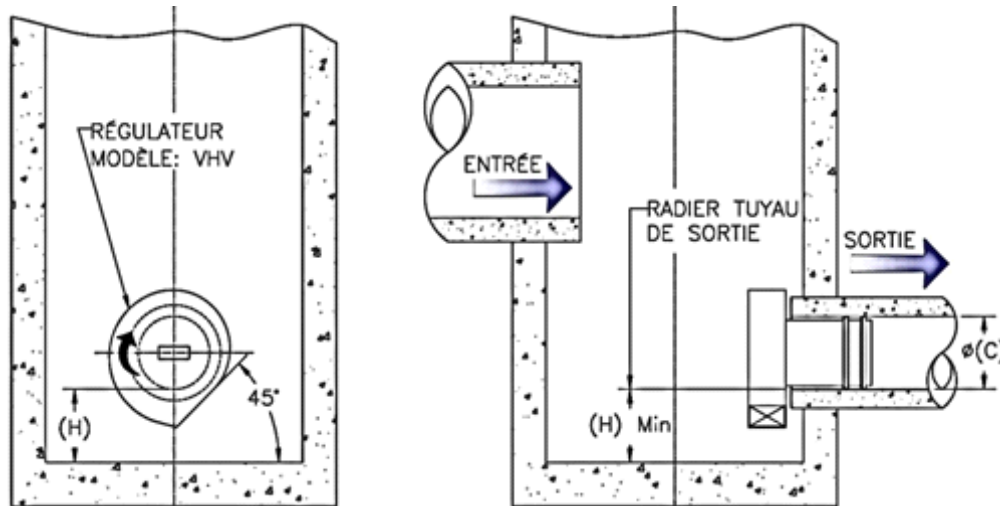

SPÉCIFICATIONS

Le régulateur de débit sera du type statique utilisant le principe du vortex et n'aura aucune partie mobile. Le débit sera régularisé sur toute la charge en utilisant uniquement les propriétés hydrauliques de l'unité. Le régulateur sera auto activé et ne nécessitera pas d'instrumentation ou alimentation externe.

Chaque régulateur de débit est constitué d'un corps à l'intérieur duquel s'effectue le contrôle de débit. Un manchon est soudé au corps pour permettre son insertion convenable à l'intérieur du tuyau de sortie du regard. Deux joints toriques en caoutchouc assurent l'étanchéité et le maintien du manchon dans le tuyau. Deux barres soudées au manchon empêchent les joints toriques de se déplacer durant l'installation et le fonctionnement.

Le régulateur sera construit entièrement à partir d'acier inoxydable 304 avec soudures continues, tel que fabriqué par Veolia Water Technologies Canada Inc. (John Meunier), 514-334-7230, cso@veolia.com.

Nom du projet: Orléans
 Numéro de projet: 601401
 Identification: ST-MH-01
 Débit (Q): 3.1 L/s
 Charge d'eau (h): 1.6 m
 Modèle: 50 VHV-1,12,OF
 # item: PRIPHY200266
 Quantité: 1

Dimensions (mm)	
A	50
B	42
L1	182
L2	164
L	200
DS	275
O1	38
O2	100
Ø ÉVENT	N/A

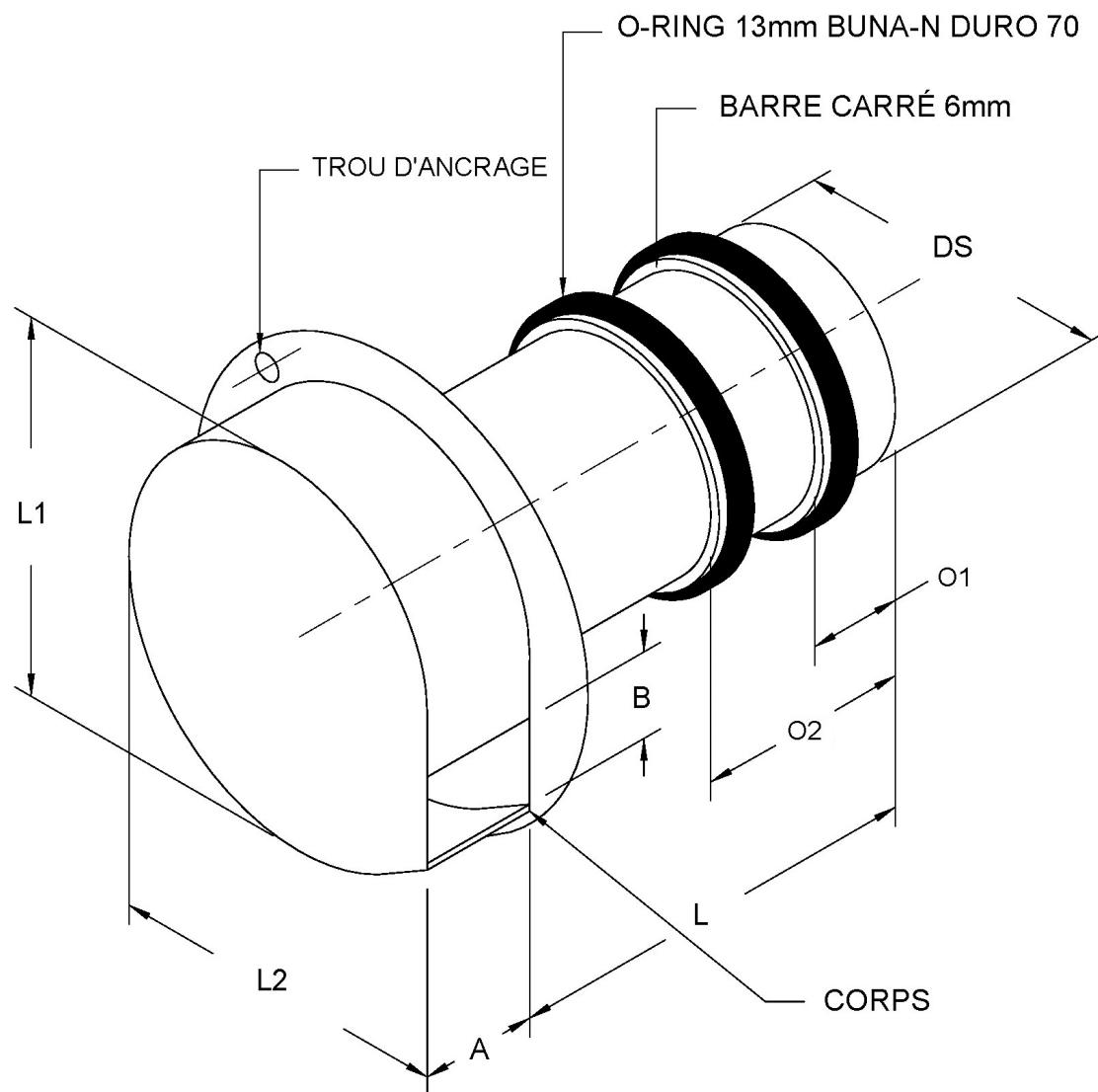

Toutes les dimensions sont en millimètres à moins avis du contraire

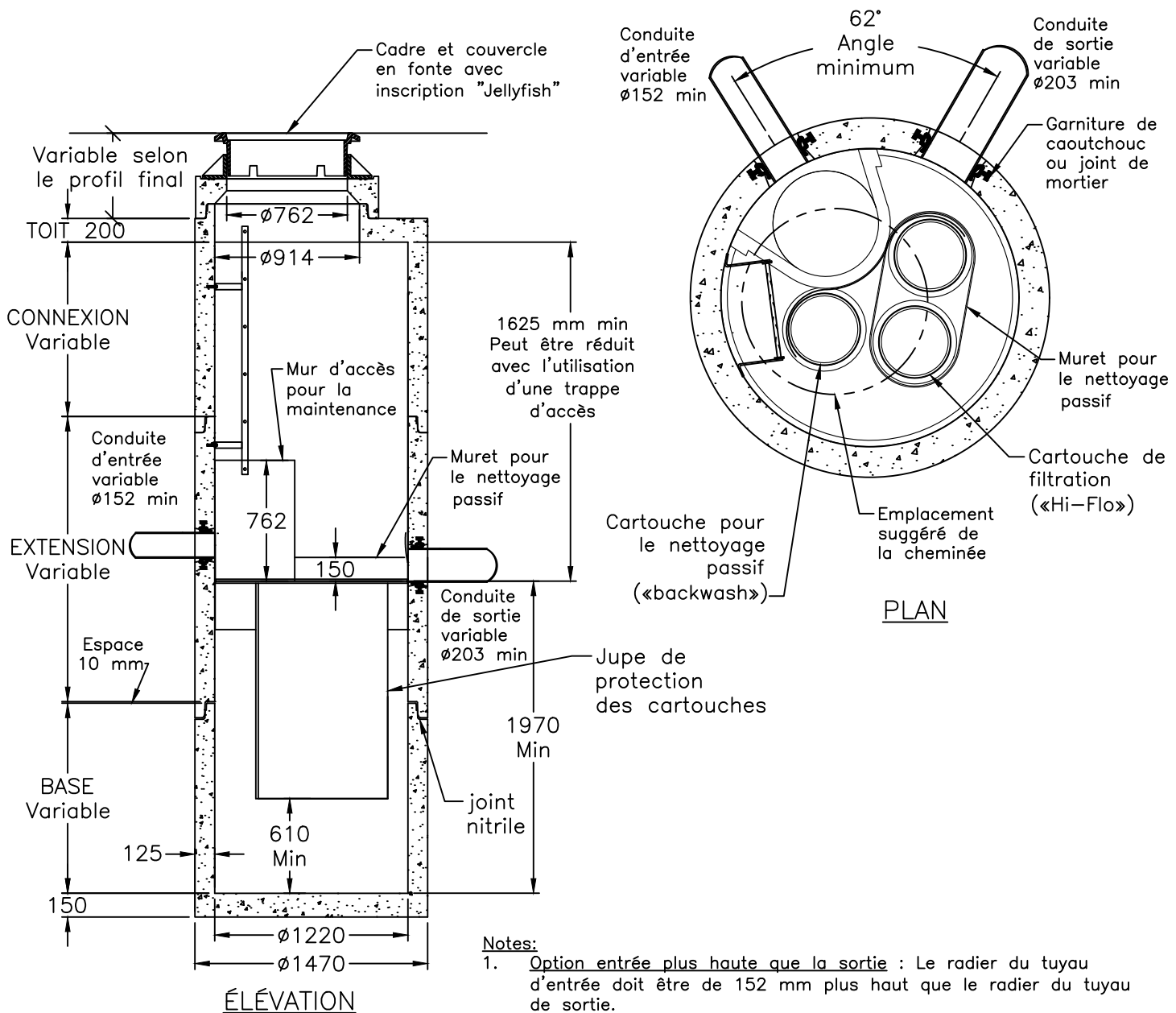

- Notes:**
1. Option entrée plus haute que la sortie : Le radier du tuyau d'entrée doit être de 152 mm plus haut que le radier du tuyau de sortie.
Option entrée plus basse que la sortie : Le radier du tuyau d'entrée doit être de 610 mm plus bas que le radier du tuyau de sortie.
 2. L'échelle et la dalle réductrice peuvent être orientées selon la position désirée par le donneur d'ouvrage. Par contre, prendre note que de changer l'orientation prévue par le manufacturier pourrait empêcher l'entretien d'être exécuté à partir de la surface.
 3. L'étanchéité au raccordement des conduites est faite à l'aide de mortier ou avec une garniture de caoutchouc.
 4. L'utilisation de garniture de caoutchouc au raccordement de la conduite pourrait ne pas être disponible pour toutes les situations. Veuillez contacter Lécuyer et fils ltée pour plus d'informations.
 5. L'installation des cartouches de filtration doit être effectuée à la fin des travaux de construction lors que le site est stabilisé et que l'unité est nettoyée et libre de tout débris.



Brevets no. CA 2696482

Critères de fabrication (pièces de béton) :

1. Selon norme BNQ 2622-420

© 2014 Tous droits de reproduction réservés
2014 All rights reserved

Note: Les dimensions cotées sont en "mm"

LECUYER TM innovation béton 17, rue du Moulin T 450 454.3928 514 861.5623 Saint-Rémi (Québec) J0L 2L0 F 450 454.7254 lecuyerbeton.com	Projet :		Description :					
	JF4		JELLYFISH Préfabriqué en béton armé JF4					
	Date :	2014-02-14	Échelle :	Aucune	Dossier No.:			
	Dessiné par :	C. Henri ing.	Plan No.:		1	18/03/20	Mise à jour fibre	SZ
	Vérifié par :	C. Henri ing.	Fichier dwg :	JF4	Rév.	Date	Description	Par

Appendix D – Sanitary Sewer Design Flows, Detailed Calculations



SANITARY SEWER DESIGN FLOWS - 500 Famille-Côté Ave

Reference : Ottawa Sewer Design Guidelines, *Infrastructure Services Department*, October 2012

A. Population Density

(Article 4.3, Table 4.2)	Number of units	Persons Per Unit	Population Density
Studio	0	1,4	0
1-bedroom	196	1,4	274
2-bedroom	158	2,1	332
3-bedroom	0	3,1	0

Total population density: 606,2

B. Average Wastewater Flows

(Article 4.4.1, Figure 4.3)

Average wastewater flow per capita for residential use: 280 L/c/d

Average wastewater flow for residential use: 169 736 L/d

Average wastewater flow for commercial use: 28 000 L/gross ha/d

Commercial Areas: 0 m² 0 L/d

C. Peaking Factors

(Article 4.4.1, Figure 4.3)

Residential peak factor: Harmon Equation

K=1

$$P.F. = 1 + \left(\frac{14}{4 + \left(\frac{P}{1000} \right)^{1/2}} \right) \times K$$

Residential peak factor: 3,93

Commercial peak factor: 1,50

D. Extraneous Flows

(Article 4.4.1.4)

Infiltration allowance: 0,28 L/s/effective gross ha for 0.90 ha

Infiltration flow: 0,25 L/s

F. Total Wastewater Design Flow

$$Q_{\text{design}} = [(3,93 \times 169\,736 \text{ L/d}) + (1,50 \times 0 \text{ L/d})] \times 1/86\,400 \text{ sec/d} + 0,25 \text{ L/s}$$

$$Q_{\text{design}} = 7,97 \text{ L/s}$$

January 21, 2025

Attention: Ravi Shanghavi

**Reference: 850 Champlain Street – Block 6
Existing Wastewater Capacity
Our File No.: 121273**

This letter provides a review of available capacity in the existing downstream sanitary sewers for the development located at 850 Champlain Street. The prospective buyer of Block 6 is looking to increase the unit density and requires confirmation of sanitary sewer capacity prior to purchase. The following reports are referenced:

- Site Servicing & Storm Water Management Report, 850 Champlain Street, Revera Subdivision, prepared by Ainley Group, dated April 3, 2017.
- Minto Commercial Properties Inc., Champlain Centre – Serviceability Report, prepared by exp Services Inc., dated July 2013.

Minto submitted a plan of subdivision in 2013 for the parcel at 850 Champlain Street wherein exp identified a peak sanitary design flow of 18.9 L/s for the entire development. Block 6 of that plan consisted of 168 apartment units with a peak design flow of 4.8 L/s.

Revera issued an updated concept in 2017 with a Long-Term Care Facility, Retirement Suites, and Office use. Previous retail use was removed from the concept and there was no change to Block 6. Ainley Group calculated a peak sanitary design flow of 22.6 L/s for the new Revera concept.

The City of Ottawa updated their sewer design guidelines in 2018 reducing the population flow from 350 L/s to 280 L/s to reflect real-world changes. This allows a reduction to the design flow from both the existing sewershed and proposed developments, thereby increasing residual sewer capacity. Increasing Block 6 to 400 apartments and applying current Ottawa design parameters yields a peak design flow of 8.1 L/s (an increase of 3.3 L/s from the draft approved flow).

Exp concluded in 2013 there was 14.4 L/s residual capacity due to a constraint in the downstream sewer at Grenoble Crescent (250mm pipe at 0.55%). Using updated design parameters and the approved draft plan, the residual sewer capacity increases to 21.8 L/s. This suggests there is sewer capacity to accommodate increasing the Block 6 density from 168 to 400 apartment units.

The proponent should be aware the City has issued a secondary plan that supports increased density along the LRT corridor and that residual capacity is typically awarded on a first-come, first-served basis. As site plan applications are approved, residual sewer capacity will gradually diminish.

Yours truly,

NOVATECH



Mark Bissett, P.Eng.
Senior Project Manager | Land Development

Appendix E – Domestic Water Demand, Detailed Calculations, Watermain Pressure



DOMESTIC WATER DEMAND CALCULATION

Reference : Ottawa Design Guidelines - Water Distribution, *Infrastructure Services department*, July 2010

A. Population Density

(Article 4.2.8, Table 4.1)	Number of units	Persons Per Unit	Population Density
Studio	0	1,4	0
1-bedroom	196	1,4	274,4
2-bedroom	158	2,1	331,8
3-bedroom	0	3,1	0
Total population density:			606

B. Average Day Demand

(Article 4.2.8, Table 4.2)

Average day demand per capita for residential use:	280 L/c/d		
Average day demand for residential use:	169 736 L/d		
Total average day demand:	169 736 L/d	=	1,96 L/s

C. Maximum Daily Demand

(Article 4.2.8, Table 4.2)

Maximum daily demand = 2.5 x 169 736 L/d			
= 424 340 L/d		=	424 340 L/d
		=	4,91 L/s

D. Maximum Hour Demand

(Article 4.2.8, Table 4.2 and Technical Bulletin ISD-2010-2)

Maximum hour demand = 2.2 x (Max Day _{res}) L/d			
Maximum hour demand = 2.2 x 424 340 L/d		=	933 548 L/d
		=	10,80 L/s

F. Results

Population density =	606	people
Average day demand =	1,96	L/s
Maximum daily demand =	4,91	L/s
Maximum hour demand =	10,80	L/s

Boundary Conditions 500 Famille-Côté

Provided Information

Scenario	Demand	
	L/min	L/s
Average Daily Demand	118.2	1.97
Maximum Daily Demand	295.2	4.92
Peak Hour	649.8	10.83
Fire Flow Demand #1	5,000	83.33

Location



Results

Connections 1 and 2 – Famille-Côté

Demand Scenario	Head (m)	Pressure ¹ (psi)
Maximum HGL	115.1	80.6
Peak Hour	109.7	72.8
Max Day plus Fire Flow #1	107.7	70.0

¹ Ground Elevation = 58.5 m

Notes

1. Any connection to a watermain 400 mm or larger should be approved by DWS as per the Water Design Guidelines Section 2.4 Review by Drinking Water Services.
2. As per the Ontario Building Code in areas that may be occupied, the static pressure at any fixture shall not exceed 552 kPa (80 psi). Pressure control measures to be considered are as follows, in order of preference:
 - If possible, systems to be designed to residual pressures of 345 to 552 kPa (50 to 80 psi) in all occupied areas outside of the public right-of-way without special pressure control equipment.
 - Pressure reducing valves to be installed immediately downstream of the isolation valve in the home/ building, located downstream of the meter so it is owner maintained.

Disclaimer

The boundary condition information is based on current operation of the city water distribution system. The computer model simulation is based on the best information available at the time. The operation of the water distribution system can change on a regular basis, resulting in a variation in boundary conditions. The physical properties of watermains deteriorate over time, as such must be assumed in the absence of actual field test data. The variation in physical watermain properties can therefore alter the results of the computer model simulation. Fire Flow analysis is a reflection of available flow in the watermain; there may be additional restrictions that occur between the watermain and the hydrant that the model cannot take into account.



Name of the project Lib Orleans 500 Côté-Famille Ave.	Project n° 601401
Client Bâtimo développement inc.	Date 2026-05-22

CONTEXT :

A connection to the existing water distribution system will be designed. It will connect the new building to the existing aqueduct pipe located on De la Famille-Côté Avenue.

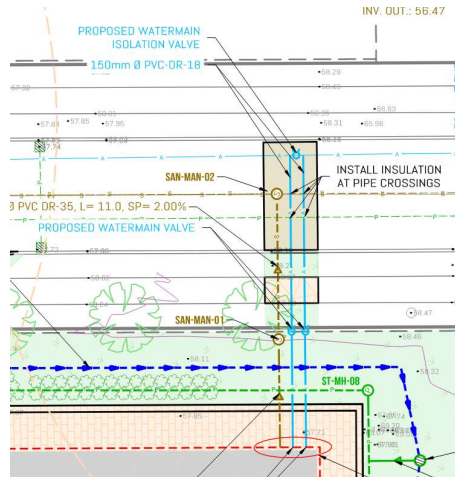

Image retrieved from civil drawings C-204. 601401_20260520_FOR SITE PLAN APPLICATION REV.02

REVISION HISTORY			
n°Rev	Date	Revised by	Reason for the revision
0	2026-05-21	Vincent Guimond	Initial version

This document was prepared by :

Prepared under supervision by :
 Vincent Guimond,
 intern

Signature

Prepared by :
 Benoit Bray, eng.
 OIQ # 100568973

Signature

1. INITIAL DATAS & HYPOTHESIS :

FLOW ¹	
Maximum daily demand :	4,92 L/s
Fire flow demand :	83,33 L/s
Total maximum flow ² :	88,25 L/s

¹Datas given by Kelsey Charie of the city of Ottawa

²This flow rate is the one passing throught the main pipe located in the street, not the one flowing towards the building

PIPING GEOMERTY ³	
Pipe material	PVC
Dimensional ratio	DR18
Pipe nominal diameter	150 mm
Inside diameter	155,00 mm
Lenght of the connection	22,10 m
Hazen-Williams coefficient	130

³Datas retrieved from civil drawings 601401_20260520_FOR SITE PLAN APPLICATION REV.02 sheet C-204.

PRESSURE ⁴	
Maximum Hydraulic grade line (HGL)	115,10 m
Minimum Hydraulic grade line (HGL)	107,70 m
Elevation at the street service point	58,50 m

⁴The HGL value is taken from a computer model simulation of the network. The value was provided by Kelsey Charie of the city of Ottawa

2. PRESSURE AT THE STREET SERVICE POINT (GROUND LEVEL)

$$\text{Maximum flow pressure : } Fp \text{ max} = HGL \text{ min} - \text{elevation} = 49,20 \text{ m} \quad | \quad 69,96 \text{ psi}$$

$$\text{Minimum flow pressure : } Fp \text{ min} = HGL \text{ max} - \text{elevation} = 56,60 \text{ m} \quad | \quad 80,49 \text{ psi}$$

3. PRESSURE AT THE BUILDING

The pressure loss is calculated for the worst case scenario (maximum flow flowing through only one of the two main entry pipes), from the main water valve to the ground level in the building.

Dynamic pressure loss

$$Hd = 10,654 * \left(\frac{Q}{C}\right)^{0,54} * \frac{1}{D^{4,87}} * L$$

$$Q = 0,033 \text{ m}^3/\text{s}$$

Where :

Q = Maximum flow in the building (m³/s)

C = Hazen-Williams coefficient

D = Internal diameter (m)

L = Length of the pipe (m)

$$Hd = 0,45 \text{ m} \quad | \quad 0,65 \text{ psi}$$

Static pressure loss

The static pressure loss is defined by comparing the elevation between two defined locations : the building connection and the service-point connection.

$$\text{Elevation at the street service point} = 56,10 \text{ m}$$

$$\text{Elevation at the building} = 55,31 \text{ m}$$

*Considering a frost depth of 2,4 m as mentioned in the civil plans, sheet C-204.

$$Hs = 0,00 \text{ m} \quad | \quad 0,00 \text{ psi}$$

Singular pressure loss

The singular pressure loss is the result of any change of geometry throughout the connection.

$$Hf_1 = \sum K * \frac{v^2}{2g}$$

$$Hf_2 = \sum \frac{1}{C_v^2} * \frac{1}{1,422} * (Q * 15850)^2$$

Where

K = Constant

v = Speed of the fluid (m/s)

g = Gravitational acceleration

Cv = Constant

Q = flow (m³/s)

$$v = \frac{Q}{\pi * \frac{d^2}{4}} = 1,7489 \text{ m/s}$$

CALCULATION NOTE

Singularity	K or Cv	Value of K or Cv	Pressure loss (m)
Water main valve	Cv	3600 ⁵	0,000
90 ° elbow	K	0,992	0,155
Sum (m) :			0,155
Sum (psi) :			0,220

⁵ Retrieved from Clow valve : <https://www.clowvalve.com/upl/downloads/clva/products/documents/general-specifications-c509.pdf>

Total pressure loss

$$H_{TOTAL} = H_d + H_f + H_s$$

$$H_{total} = 0,61 \text{ m} \quad | \quad 0,87 \text{ psi}$$

Safety factor (Sf) : 10%

$$H_{total} \text{ (with Sf)} = 0,67 \text{ m} \quad | \quad 0,95 \text{ psi}$$

4. RESULTS

$$\text{Dynamic pressure at the water main valve (max flow)} = 48,53 \text{ m} \quad | \quad 69,01 \text{ psi}$$

$$\text{Static pressure at the water main valve (min flow)} = 55,93 \text{ m} \quad | \quad 79,53 \text{ psi}$$

5. CONCLUSION & DISCUSSION

According to the Design Guideline for Drinking-Water Systems, chapter 10, the minimum pressure under maximum day demand plus fire flow is 20 psi and the minimum pressure in normal operation is 40 psi.

The calculated dynamic pressure (48,94 psi) is greater than the minimum of 20 psi and the calculated static pressure (56,34 psi) is greater than the minimum of 40 psi.

The pressure is therefore compliant to the Design guideline for Drinking-Water Systems.

Appendix F – Required Fire Demand, Detailed Calculations



REQUIRED FIRE DEMAND CALCULATION

References : Ottawa Technical Bulletin ISTB-2018-02, March 2018
 Water Supply for Public Fire Protection, *Fire Underwriters Survey*, 1999

A. Type of construction

Non-combustible construction : $C = 0,8$

B. Total Floor Area

	Surface Area Per Floor	Number of Floors	Floor Area
Ground Floor	3 301 m ²	1	3 301 m ²
Level 2	3 105 m ²	1	3 105 m ²
Level 3	3 106 m ²	1	3 106 m ²
Level 4	3 104 m ²	1	3 104 m ²
Level 5	1 960 m ²	1	1 960 m ²
Levels 6-12	2 045 m ²	7	14 315 m ²
Levels 13-14	1 153 m ²	2	2 306 m ²
		<i>Total:</i>	31 197

A = Largest floor area + 25% of each of the two immediately adjoining floors

$$A = 3301\text{m}^2 + 25\% * 3105\text{m}^2 + 25\% * 3105\text{m}^2$$

$$A = 4854\text{m}^2$$

D. Base Fire Flow

$$F = 220 \times C\sqrt{A} = 12\,261 \text{ L/min}$$

The base fire flow must be rounded up to the nearest 1,000 L/min, hence : $F = 13\,000 \text{ L/min}$

E. Fire Flow Adjustments

E.1 Building occupancy (adjustments to the value obtained in D)

Occupancy : Non-combustible -25% $F = 9\,750 \text{ L/min}$ ①

E.2 Automatic sprinkler system (adjustments to the value obtained in E.1)

NPFA 13 Designed system: Yes -30%
 Standard water supply: Yes -10%
 Fully supervised system: Yes -10%



E.3 Exposure surcharge (adjustments to the value obtained in E.1)

Length-Height Factors

North side	No adjacent building
East side	No adjacent building
South side	Height of adjacent building < building height
West side	Height of adjacent building < building height

North side	No adjacent building	0%
East side	No adjacent building	0%
South side	47,3m (> 45m)	0%
West side	52m (> 45m)	0%

Reductions from E.2 = -50% = -4 875 L/min ②

Increases from E.3 = 0% = 0 L/min ③

① + ② + ③ $F = 4\ 875$ L/min

The fire flow must be rounded up to the nearest 1,000 L/min, hence : $F = 5\ 000$ L/min

F. volume of Water Required During the Fire

The duration of water supply for a fire is: 2 hours

Required Volume = 600 000 L = 600 m³

Fire Demand = 5 000 L/min Required Volume = 600 m³

Fire Flow Requirement - OBC

500 de la Famille-Côté Avenue

A. Total Building volume (m3)

	Surface Area Per Floor	Number of Floors	Floor Area	Floors height	Volume Per Floor
Ground Floor	3 301 m ²	1	3 301 m ²	3,66 m	12 082 m ³
Level 2	3 105 m ²	1	3 105 m ²	2,845	8 834 m ³
Level 3	3 106 m ²	1	3 106 m ²	2,845 m	8 837 m ³
Level 4	3 104 m ²	1	3 104 m ²	2,995 m	9 296 m ³
level 5	1 960 m ²	1	1 960 m ²	2,846 m	5 578 m ³
Levels 6-12	2 045 m ²	7	14 315 m ²	2,845 m	40 726 m ³
Level 13	1 153 m ²	1	1 153 m ²	2,845 m	3 280 m ³
Level 14	1 153 m ²	1	1 153 m ²	2,996 m	3 454 m ³
			Total A =		92 087 m³

B. Fire Flow

Q = KVStot

Q Minimum supply of water in litres

K Water supply coefficient from Table 1

V Total building volume in cubic meters

Stot Total of spatial coefficient values from property line exposures on all sides – Refer to Formula associated with A-3.2.5.7 in OBC.

C. Water Supply Coefficient

Building Group: C (Residential Occupancies)

Table 1; K = 10

(Refer to Architect's email for Type of Construction)

D. Spatial Coefficient

Building Face	Exposure Distance	Spatial Coefficient
North	More than 10m	0,0
East	More than 10m	0,0
South	More than 10m	0,0
West	More than 10m	0
Total		0,0

Stot = 1.0 + (Sum of side spatial coefficient)

Stot = 1,0

E. Required Fire Flow

Q = KVStot

Q= 920874,4

Liters

Based on Table 2 of A-3.2.5.7 OBC, the required minimum water supply flow rate is : 9000 Lpm or 150L/s