

Waste Collection Truck

meters

Width : 2.60  
 Track : 2.60  
 Lock to Lock Time : 6.0  
 Steering Angle : 27.7

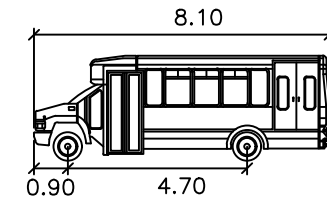

Shuttle Bus

meters

Width : 2.40  
 Track : 2.40  
 Lock to Lock Time : 6.0  
 Steering Angle : 35.5

4.75m x 8m  
LOADING SPACE

4m x 12m  
SHUTTLE BUS PARKING

BAREILLE-SNOW STREET

# Robinson

## Land Development

scale	1:300	WATERIDGE LIFESTYLES	project no.	25117
date	10/06/26		SWEPT PATH ANALYSIS - GARBAGE TRUCK IN	FIG A
drawn by	BLM			

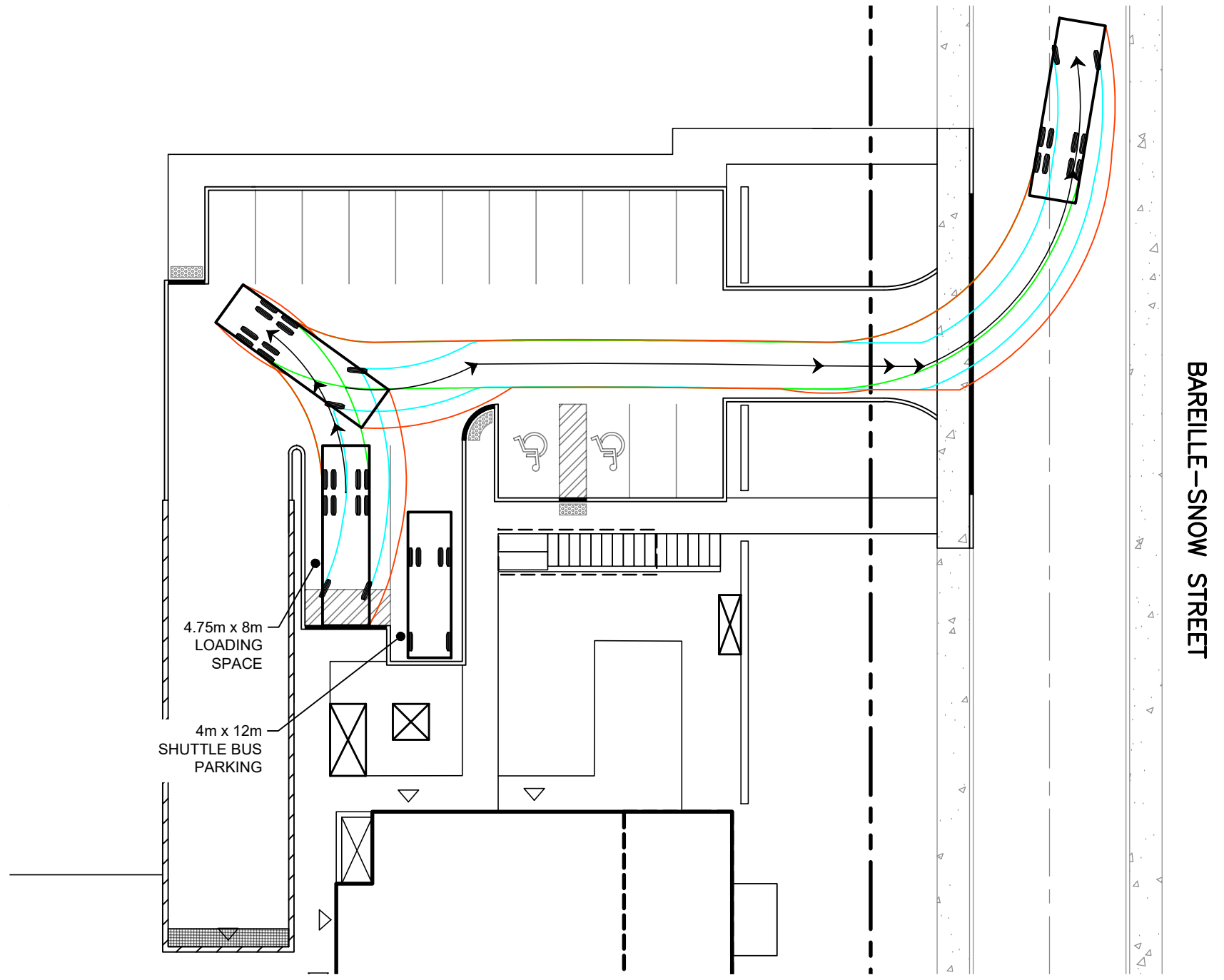

4.75m x 8m  
LOADING  
SPACE

4m x 12m  
SHUTTLE BUS  
PARKING

BAREILLE-SNOW STREET

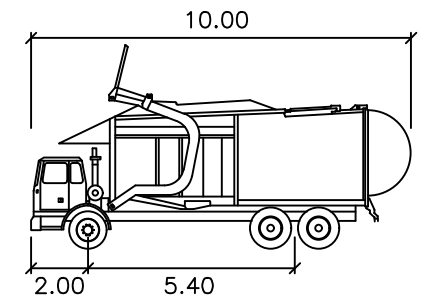

Waste Collection Truck

meters

Width : 2.60  
Track : 2.60  
Lock to Lock Time : 6.0  
Steering Angle : 27.7

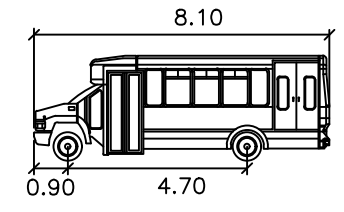

Shuttle Bus

meters

Width : 2.40  
Track : 2.40  
Lock to Lock Time : 6.0  
Steering Angle : 35.5

# Robinson

## Land Development

scale	1:300	WATERIDGE LIFESTYLES	project no.	25117
date	10/06/26		SWEPT PATH ANALYSIS – GARBAGE TRUCK OUT	FIG B
drawn by	BLM			

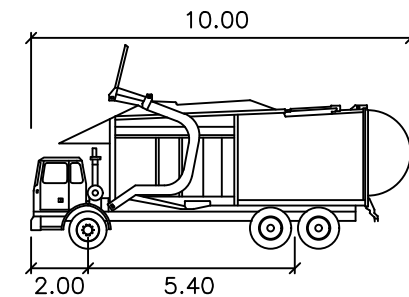
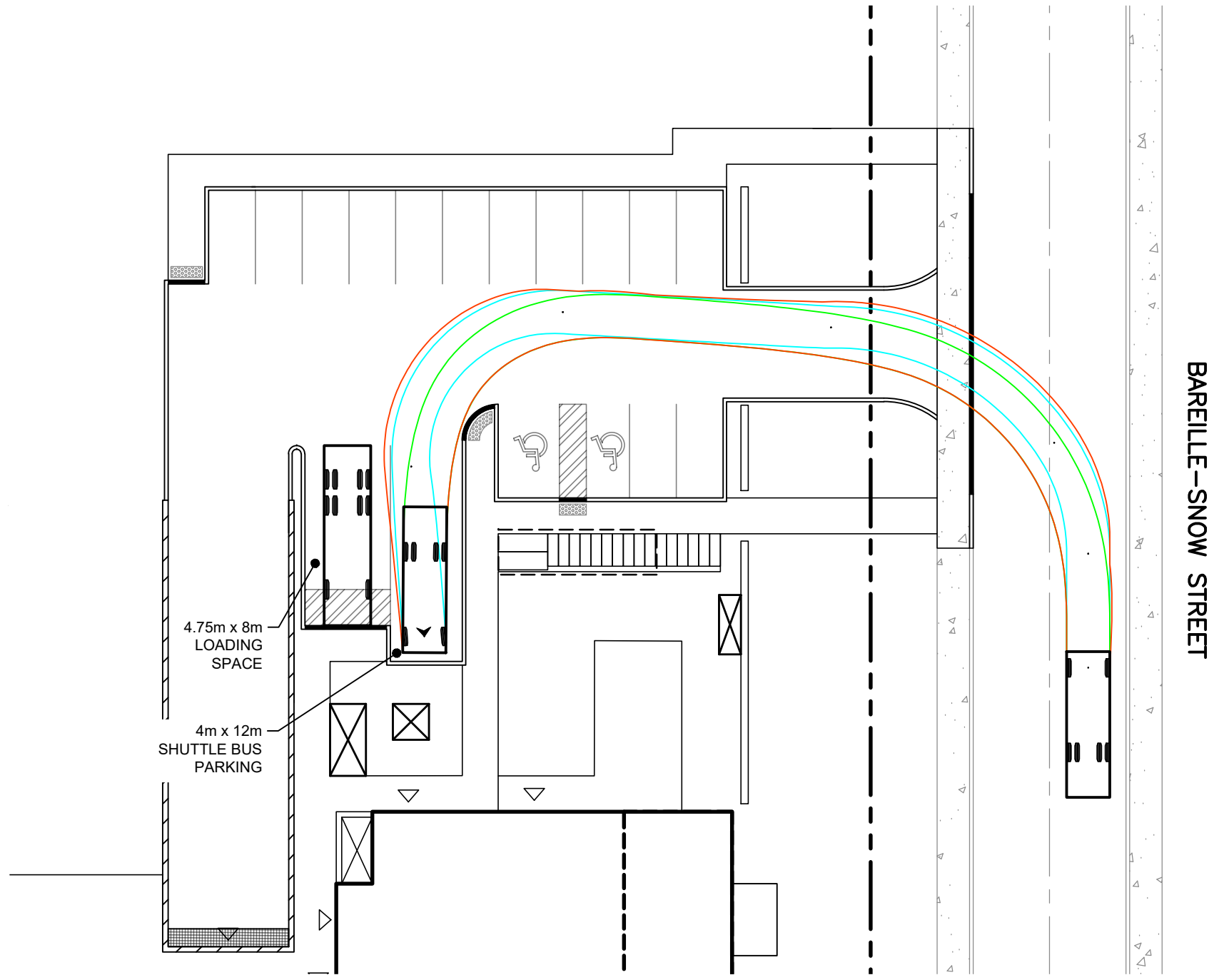

Waste Collection Truck

meters

Width : 2.60  
 Track : 2.60  
 Lock to Lock Time : 6.0  
 Steering Angle : 27.7

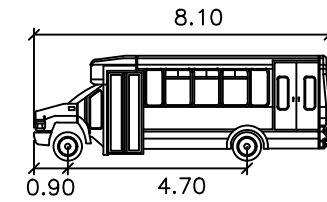

Shuttle Bus

meters

Width : 2.40  
 Track : 2.40  
 Lock to Lock Time : 6.0  
 Steering Angle : 35.5

# Robinson

## Land Development

scale	1:300	WATERIDGE LIFESTYLES	project no.	25117
date	10/06/26		SWEPT PATH ANALYSIS – SHUTTLE BUS IN	FIG C
drawn by	BLM			

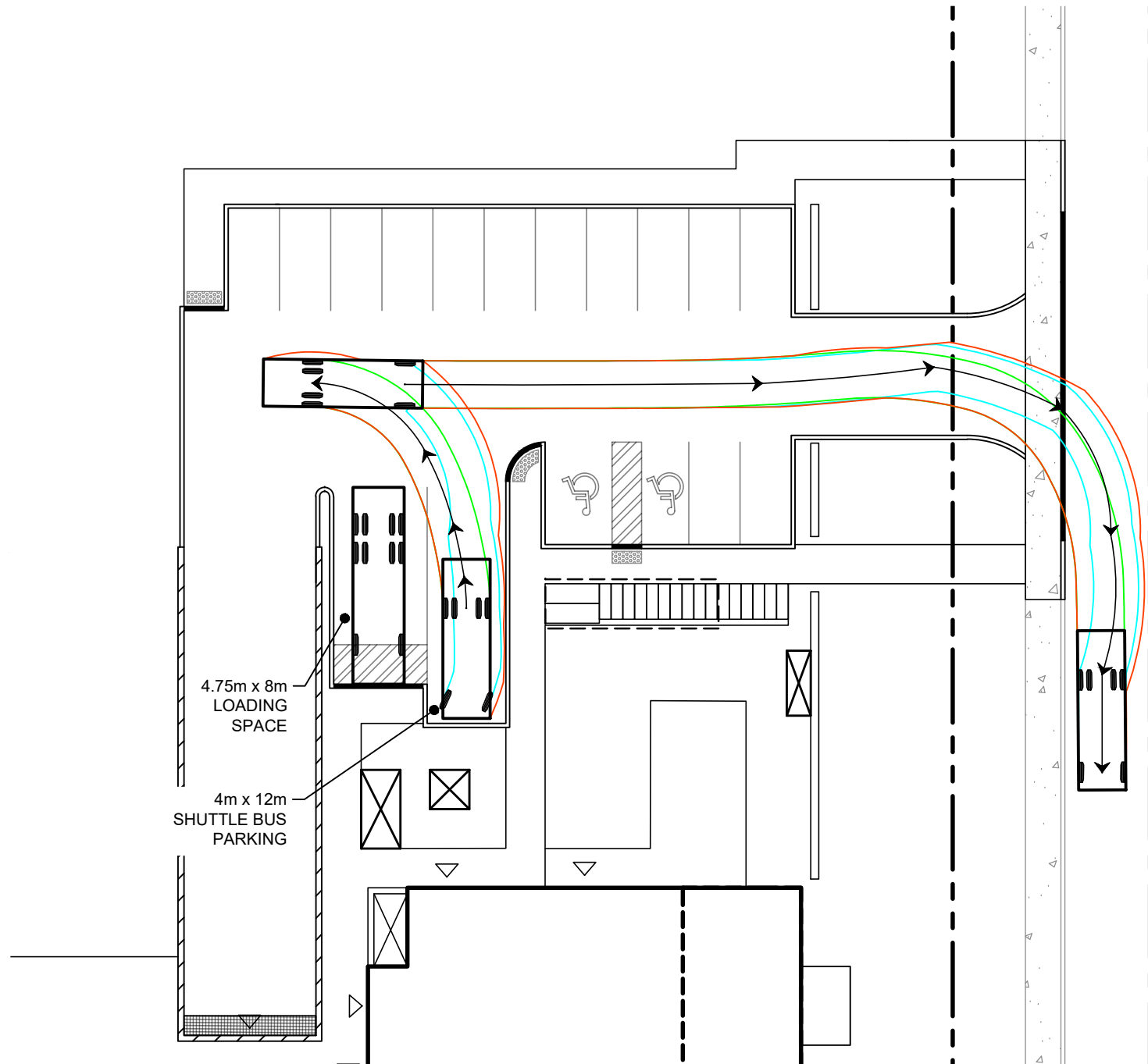

BAREILLE-SNOW STREET

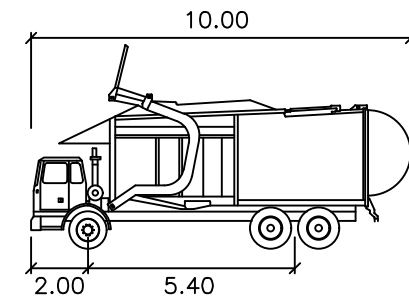

Waste Collection Truck

meters

Width : 2.60  
 Track : 2.60  
 Lock to Lock Time : 6.0  
 Steering Angle : 27.7

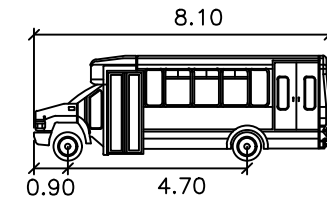

Shuttle Bus

meters

Width : 2.40  
 Track : 2.40  
 Lock to Lock Time : 6.0  
 Steering Angle : 35.5

# Robinson

## Land Development

<small>scale</small>	1:300	<small>project no.</small>	25117
<small>date</small>	10/06/26	WATERIDGE LIFESTYLES	
<small>drawn by</small>	BLM	SWEPT PATH ANALYSIS – SHUTTLE BUS OUT	
			FIG D