

4

LEGISLATION, REGULATION AND CODES:

1. ALL WORK WITHIN THE CITY RIGHT-OF-WAY SHALL BE CONSTRUCTED ACCORDING TO THE LATEST CITY OF OTTAWA STANDARD DRAWINGS AND SPECIFICATIONS, ONTARIO PROVINCIAL STANDARD DRAWINGS AND SPECIFICATIONS MAY, SUBJECT TO THE APPROVAL OF CITY OF OTTAWA, BE USED WHERE NO CITY STANDARD OR SPECIFICATION IS AVAILABLE.
2. ALL WORK SHALL BE COMPLETED ACCORDING TO THE CURRENT OCCUPATIONAL HEALTH AND SAFETY ACT AND REGULATIONS FOR CONSTRUCTION PROJECTS. THE GENERAL CONTRACTOR SHALL BE DEEMED TO BE THE CONSTRUCTOR AS DEFINED IN THE ACT.
3. ALL TEMPORARY TRAFFIC CONTROL AND SIGNAGE DURING CONSTRUCTION SHALL BE ACCORDING TO THE CURRENT ONTARIO TRAFFIC MANUAL BOOK 7: TEMPORARY CONDITIONS FIELD EDITION.
4. ANY PERSON AUTHORIZED TO CARRY OUT WORK ON WATERMANS, SHALL COMPLY WITH THE QUALITY MANAGEMENT SYSTEM (QMS).

CONSTRUCTION NOTES:

1. ALL AREAS DISTURBED DURING CONSTRUCTION WITHIN THE CITY'S RIGHT-OF-WAY SHALL BE RESTORED TO ORIGINAL OR BETTER CONDITION AND TO THE SATISFACTION OF THE CONTRACT ADMINISTRATOR. GRASS AREAS SHALL BE TREATED WITH 100mm OF TOPSOIL AND SHALL BE SOODED ACCORDING TO THE CITY STANDARDS.
2. ALL EXISTING UTILITIES SHOWN ON DRAWINGS (PLAN AND PROFILE) ARE FOR REFERENCE PURPOSES ONLY. THE CONTRACTOR SHALL SATISFY THEMSELVES AS TO THE ACTUAL LOCATION AND DEPTH OF ANY UTILITY AND SHALL BE LIABLE FOR ALL OR ANY DAMAGE.
3. ANY DISCREPANCIES BETWEEN SITE CONDITIONS AND CONSTRUCTION DRAWINGS MUST BE REPORTED TO THE ENGINEER PRIOR TO COMMENCEMENT OF CONSTRUCTION AND APPROPRIATE ACTION TAKEN TO THE SATISFACTION OF THE CONTRACT ADMINISTRATOR.
4. ALL SURVEY STAKE LAYOUT POINTS SHALL BE VERIFIED IN THE FIELD BY THE CONTRACTOR PRIOR TO CONSTRUCTION. ANY DISCREPANCIES BETWEEN THE DRAWINGS AND THE LAYOUT SHALL BE IMMEDIATELY REPORTED TO THE ENGINEER.
5. ATTENTION IS DIRECTED TO THE POSSIBILITY OF EXISTING PRIVATE SPRINKLERS AND LIGHTING SYSTEMS WITHIN THE RIGHT-OF-WAY, WHICH ARE NOT SHOWN ON THE PLANS. LOCATING, WORKING AROUND AND PROTECTING THESE SYSTEMS SHALL BE COMPLETED AT NO EXTRA COST TO THE REGIONAL MUNICIPALITY OF CITY.
6. ALL DIMENSIONS ARE EXPRESSED IN METERS (m) AND PIPE SIZES ARE EXPRESSED IN MILLIMETERS (mm) UNLESS OTHERWISE NOTED.
7. ALL MATERIAL FOR SEWER, FORCEMAIN, WATERMAIN, HYDRANTS AND APPURTENANCES, SHALL BE ACCORDING TO THE CITY OF OTTAWA STANDARDS/ GUIDELINES.
8. SERVICE CONNECTIONS AND UTILITY CUTS MADE IN ROAD PAVEMENTS SHALL BE BACKFILLED WITH UNSHRINKABLE FILL.
9. AT ALL LOCATIONS WHERE THE PROPOSED WATERMAIN CROSSES UNDER OR ABOVE THE EXISTING SEWERS, OR UTILITIES, GRANULAR 'A' NATIVE OR GRANULAR 'A' RCM BEDDING MATERIAL IS TO EXTEND FROM THE LOWER PIPE TO THE TOP OF THE UPPER PIPE. GRANULAR 'A' NATIVE OR GRANULAR 'A' RCM TO BE COMPACTED TO MINIMUM 98% OF MAXIMUM DRY DENSITY.
10. CONTRACTOR TO PROVIDE ADEQUATE SUPPORT DURING CONSTRUCTION BETWEEN THE NEW WATERMAIN AND EXISTING GAS MAINS. MAINTAIN 300mm MINIMUM VERTICAL CLEARANCES BETWEEN THE NEW WATERMAIN AND EXISTING GAS MAINS LESS THAN 300mm IN DIAMETER. MAINTAIN 600mm MINIMUM VERTICAL CLEARANCES BETWEEN THE NEW WATERMAIN AND EXISTING GAS MAINS EQUAL TO OR GREATER THAN 300mm DIAMETER.
11. ALL EXISTING WATERMANS AND SEWER PIPES LARGER THAN 300mm DIAMETER SHALL BE SUPPORTED ACCORDING TO THE CITY OF OTTAWA.

WATERMAIN NOTES:

1. ALL WATERMAIN MATERIALS AND INSTALLATION SHALL CONFORM TO THE LATEST REVISIONS OF THE STANDARDS AND SPECIFICATIONS OF CITY OF OTTAWA, ONTARIO PROVINCIAL STANDARD DRAWINGS (OPSD) AND SPECIFICATIONS (OPSS).
2. PVC WATERMANS SHALL BE MINIMUM DR 18 CLASS 235 (AWWA) C900-07 OR MOLECULARLY ORIENTED POLYVINYL CHLORIDE (PVC) PIPES RANGING IN SIZE FROM 100mm TO 300mm DIA. PRESSURE CLASS 235 AWWA C909-09. PVC PIPES RANGING IN SIZE FROM 350mm THROUGH 600mm DIA., SHALL BE PRESSURE RATING 235, DR 18, ACCORDING TO AWWA C905-10.
3. NO WORK SHALL COMMENCE UNLESS A CITY WATER WORKS INSPECTOR IS ON SITE. WATERMAIN CONNECTIONS BY CITY OF OTTAWA FORCES WITH ALL EXCAVATION BACKFILL AND ROAD REINSTATEMENT BY CONTRACTOR.
4. VALVE BOXES SHALL BE INSTALLED AS PER CITY OF OTTAWA.
5. ALL CURB AND VALVE BOXES TO BE LOCATED AT STREET LINE.
6. ALL FIRE HYDRANTS TO BE CONSTRUCTED, INSTALLED AND LOCATED AS PER CITY OF OTTAWA STANDARDS.
7. HYDRANT LEADS SHALL BE MINIMUM DR 18 CLASS 235 (AWWA) C900-07 OR PRESSURE CLASS 235 AWWA C909-09.
8. EMBEDMENT MATERIAL FOR FLEXIBLE PIPE SHALL BE ACCORDING TO OPSD 802.010 AND USING GRANULAR 'A' NATIVE OR GRANULAR 'A' RCM AND COMPACTED TO MINIMUM 98% OF MAXIMUM DRY DENSITY.
9. ALL WATERMANS TO BE INSTALLED AT MINIMUM COVER OF 1.8m.
10. IF WATERMAIN MUST BE DEFLECTED TO MEET ALIGNMENT, ENSURE THAT THE AMOUNT OF DEFLECTION USED IS LESS THAN HALF THAT RECOMMENDED BY THE MANUFACTURER.
11. DISINFECTION AND TESTING OF WATERMAIN TO BE IN ACCORDANCE WITH CITY OF OTTAWA STANDARDS.
12. WATER METERS TO BE INSTALLED AS PER CITY OF OTTAWA STANDARDS.
13. THE CONTRACTOR SHALL PROVIDE ALL TEMPORARY CAPS, PLUGS AND BLOW-OFFS AND NOZZLES REQUIRED FOR TESTING AND DISINFECTION OF THE WATERMAIN.
14. INSULATION FOR WATERMAIN CROSSING OVER AND BELOW SEWER SHALL BE IN ACCORDANCE WITH CITY OF OTTAWA STANDARDS, WHERE WATERMAIN COVER IS LESS THAN 1.7m.
15. WHERE THE SEPARATION BETWEEN SERVICES AND MANHOLES IS LESS THAN 2.5m, WATER SERVICES ARE TO BE INSULATED AS PER CITY OF OTTAWA STARDS.
16. WATERMANS MUST FOLLOW THE ONTARIO MINISTRY OF THE ENVIRONMENT PROCEDURE F-6-1 THAT GOVERNS THE SEPARATION OF SEWERS AND WATERMANS. A MINIMUM VERTICAL CLEARANCE OF 0.30m WHEN CROSSING OVER AND 0.50m WHEN CROSSING UNDER SEWERS AND ALL OTHER UTILITIES IS REQUIRED. WATERMANS MUST ALSO MAINTAIN 2.5m HORIZONTAL SEPARATION WITH SEWERS. ADEQUATE STRUCTURAL SUPPORT FOR THE SEWERS IS REQUIRED TO PREVENT EXCESSIVE DEFLECTION OF JOINTS AND SETTLING. THE LENGTH OF WATER PIPE SHALL BE CENTERED AT THE POINT OF CROSSING SO THAT THE JOINTS WILL BE EQUIDISTANT AND AS FAR AS POSSIBLE FROM THE SEWER.
17. MECHANICAL THRUST RESTRAINTS SHALL BE INSTALLED AT ALL FITTINGS, BENDS, TEES, CROSSES, REDUCERS, VALVES, CAPS AND PLUGS FOR ALL WATERMAIN SIZES. MECHANICAL RESTRAINTS AT JOINTS SHALL BE INSTALLED AT EVERY PIPE JOINT WITHIN 6.1m OF EITHER SIDE OF ALL FITTINGS FOR WATERMANS 100mm DIA. OR LARGER.
18. CITY IN-SERVICE WATER VALVES, CURB STOPS, FIRE HYDRANTS CAN ONLY BE OPERATED BY CITY STAFF OR REPRESENTATIVES.
19. ALL NEW WATERMANS SHALL BE INSULATED WHERE THE COVER IS LESS THAN 1.65m.

WATERMAIN - FILL AREAS:

1. PIPES ARE NOT TO BE LAID ON FILL UNTIL THE FIELD DENSITY TEST REPORTS HAVE BEEN SUBMITTED AND APPROVED BY THE ENGINEER.
2. FILL TO BE PLACES TO A MINIMUM OF 600mm ABOVE THE WATERMAIN GRADES AND 3m MINIMUM ON EACH SIDE PRIOR TO WATERMAIN LAYING COMPACTED TO A MINIMUM OF 100% OF MAXIMUM DRY DENSITY IN 300mm LIFTS.
3. SOIL DENSITY TESTS SHALL BE TAKEN ALONG CENTERLINE OF THE WATERMAIN AND ON LINES 1.5m ON EITHER SIDE OF SAME AT A MAXIMUM INTERVAL OF 30m. TESTS TO BE TAKEN AT EACH 600mm LIFT.
4. ALL HYDRANTS, TEES, VALVES, BENDS, PLUGS AND EACH PIPE JOINT ARE TO BE MECHANICALLY RESTRAINED.
5. PIPE JOINT DEFLECTIONS ARE NOT ALLOWED.

EROSION AND SEDIMENT CONTROL:

1. EROSION AND SEDIMENT CONTROL (ESC) MEASURES WILL BE IMPLEMENTED PRIOR TO, AND MAINTAINED DURING CONSTRUCTION PHASES, TO PREVENT ENTRY OF SEDIMENT INTO THE WATER. ALL DAMAGED EROSION AND SEDIMENT CONTROL MEASURES SHOULD BE REPAIRED OR REPLACED, OR BOTH, WITHIN 48 HOURS OF INSPECTION.
2. ALL DISTURBED AREAS WILL BE MINIMIZED TO THE EXTENT POSSIBLE, AND TEMPORARILY OR PERMANENTLY STABILIZED OR RESTORED AS THE WORK PROGRESSES.
3. THE EROSION AND SEDIMENT CONTROL STRATEGIES OUTLINED ON THE PLANS ARE NOT STATIC AND MAY NEED TO BE UPGRADED/AMENDED AS SITE CONDITIONS CHANGE TO MINIMIZE SEDIMENT LOADS RUNOFF FROM LEAVING THE WORK AREA. IF THE PRESCRIBED MEASURES ON THE PLANS ARE NOT EFFECTIVE IN PREVENTING RELEASE OF A DELETERIOUS SUBSTANCE, THEN ALTERNATIVE MEASURES MUST BE IMPLEMENTED IMMEDIATELY TO MINIMIZE POTENTIAL ECOLOGICAL IMPACTS AND A TORONTO REGION CONSERVATION AUTHORITY ENFORCEMENT OFFICE SHOULD BE IMMEDIATELY CONTACTED. ADDITIONAL ESC MEASURES TO BE KEPT ON SITE AND USED AS NECESSARY.
4. ALL ACTIVITIES, INCLUDING MAINTENANCE PROCEDURES, WILL BE CONTROLLED TO PREVENT THE ENTRY OF PETROLEUM PRODUCTS, DEBRIS, RUBBLE, CONCRETE OR OTHER DELETERIOUS SUBSTANCES INTO THE WATER. VEHICULAR REFUELING AND MAINTENANCE WILL BE CONDUCTED A MINIMUM OF 30m FROM THE WATER.

5. ALL GRADES WITHIN THE REGULATORY FLOOD PLAN WILL BE MAINTAINED OR MATCHED.

SANITARY SERVICE NOTES:

1. ALL SANITARY SEWER MATERIALS AND INSTALLATION SHALL CONFORM TO THE LATEST REVISIONS OF THE STANDARDS AND SPECIFICATIONS OF THE CITY OF OTTAWA, ONTARIO PROVINCIAL STANDARD DRAWINGS (OPSD) AND SPECIFICATIONS (OPSS).
2. ALL SANITARY SEWERS SHALL BE PVC DR 28, INSTALLED AT 2%, UNLESS OTHERWISE NOTED.
3. SANITARY SERVICE CONNECTIONS SHALL BE SINGLE, 150mm DIA. MINIMUM, PVC DR 28 INSTALLED AT 2%.
4. SANITARY MAINTENANCE HOLES SHALL HAVE WATERTIGHT FRAMES AND COVERS IN PONDING AREAS ACCORDING TO OPSD 401.030.

STORM SERVICE NOTES:

1. ALL STORM SEWER MATERIALS AND INSTALLATION SHALL CONFORM TO THE LATEST REVISIONS OF THE STANDARDS AND SPECIFICATIONS OF THE CITY OF OTTAWA, ONTARIO PROVINCIAL STANDARD DRAWINGS (OPSD) AND SPECIFICATIONS (OPSS).
2. ALL REINFORCED CONCRETE STORM SEWER PIPE SHALL BE IN ACCORDANCE WITH CSA A257.2 (LATEST AMENDMENT), ALL NON-REINFORCED CONCRETE STORM SEWER PIPE SHALL BE IN ACCORDANCE WITH CSA A257.1 (LATEST AMENDMENT), PIPE SHALL BE JOINTED WITH STD. RUBBER GASKETS AS PER CSA A257.3 (LATEST AMENDMENT).
3. EMBEDMENT MATERIAL FOR FLEXIBLE PIPE SHALL BE ACCORDING TO OPSD 802.010 AND USING GRANULAR 'A' NATIVE OR GRANULAR 'A' RCM BEDDING MATERIAL AND COMPACTED TO MINIMUM 98% OF MAXIMUM DRY DENSITY.
4. BEDDING FOR RIGID PIPE SHALL BE CLASS 'B' BEDDING MATERIAL ACCORDING TO OPSD 802.031 AND USING GRANULAR 'A' NATIVE OR GRANULAR 'A' RCM BEDDING MATERIAL ACCORDING TO TS 1010 AND COMPACTED TO MINIMUM 98% OF MAXIMUM DRY DENSITY.
5. MINIMUM SOIL COVER TO BE 1.9m TO PROTECT SEWERS FROM FROST DAMAGE. IN AREAS WHERE ADEQUATE FROST COVER CANNOT BE ACHIEVED, EQUIVALENT THERMAL INSULATION TO BE INSTALLED AS PER DETAIL 1 CS300.
6. STORM MANHOLE FRAME AND COVERS SHALL BE AS PER OPSD 701.010(1200mmØ) AND CBS SHALL BE AS PER OPSD 705.010.
7. SAFETY PLATFORMS SHALL BE IN ACCORDANCE WITH OPSD 404.02.
8. CONTRACTOR SHALL ENSURE THAT CATCHBASINS ARE INSTALLED AT THE LOW POINT OF SAG CURB WORKS.
9. THE STORM SEWER CLASSES HAVE BEEN DESIGNED BASED ON BEDDING CONDITIONS SPECIFIED. WHERE THE SPECIFIED TRENCH WIDTH IS EXCEEDED, THE CONTRACTOR SHALL BE REQUIRED TO PROVIDE ADDITIONAL BEDDING, A DIFFERENT TYPE OF BEDDING OR A HIGHER PIPE STRENGTH AT HIS OWN EXPENSE AND SHALL ALSO BE RESPONSIBLE FOR EXTRA TEMPORARY AND/OR PERMANENT REPAIRS MADE NECESSARY BY THE WIDENED TRENCH.
10. THE CONTRACTOR SHALL CONDUCT CCTV INSPECTION OF ALL NEWLY INSTALLED STORM SEWERS AND EXISTING SEWERS CONNECTED TO. THE TEST SHALL BE PERFORMED IMMEDIATELY AFTER SEWERS INSTALLED.
11. SINGLE CATCHBASINS SHALL BE ACCORDING TO 705.010 COMPLETE WITH GOSS TRAP, WHERE SPECIFIED. FRAME AND COVER SHALL BE ACCORDING TO OPSD 400.070.
12. CATCHBASIN LEADS TO BE 250mm PVC DR 35 FOR SINGLE CATCHBASINS AND 300mm PVC DR 35 FOR DOUBLE CATCHBASINS. THEY ARE TO BE AT A 1.0% SLOPE (MIN) UNLESS OTHERWISE NOTED.
13. CONNECTION DETAIL FOR SEWER PIPE AT CATCHBASINS AND MAINTENANCE HOLES SHALL BE ACCORDING TO OPSD 708.020.

GENERAL NOTES:

1. ALL WORKS AND MATERIALS SHALL CONFORM TO THE LATEST REVISIONS OF THE STANDARDS AND SPECIFICATIONS OF CITY OF OTTAWA, ONTARIO PROVINCIAL STANDARD DRAWINGS (OPSD) AND SPECIFICATIONS (OPSS), WHERE APPLICABLE.
2. THE LOCATION OF UTILITIES IS APPROXIMATE ONLY, AND THE EXACT LOCATION SHOULD BE DETERMINED BY CONSULTING THE MUNICIPAL AUTHORITIES AND UTILITY COMPANIES CONCERNED. THE CONTRACTOR IS RESPONSIBLE TO PROVIDE THE LOCATION AND STATUS OF UTILITIES AND SHALL BE RESPONSIBLE FOR ADEQUATE PROTECTION OF PLANT AND EQUIPMENT FROM DAMAGE. THE CONTRACTOR SHALL BE RESPONSIBLE FOR REPAIR OR REPLACEMENT OF ANY SERVICES OR UTILITIES DISTURBED DURING CONSTRUCTION, TO THE SATISFACTION OF THE AUTHORITY HAVING JURISDICTION.
3. THE CONTRACTOR SHALL VERIFY THE LOCATION AND ELEVATION OF EXISTING SERVICES PRIOR TO ANY CONSTRUCTION. THE CONTRACTOR SHALL CONFIRM LOCATIONS AND ELEVATIONS OF EXISTING SERVICES AND STRUCTURES TO BE CONNECTED TO AND EXISTING SERVICES THAT MAY BE DAMAGED OR CAUSE CONFLICTS PRIOR TO CONSTRUCTION OF ANY NEW SEWER, WATER AND/OR STORM WATER WORKS. ALL DIMENSIONS SHALL BE CHECKED AND VERIFIED IN THE FIELD BY THE CONTRACTOR PRIOR TO THE START OF CONSTRUCTION. ANY DISCREPANCIES, INTERPRETATIONS, CHANGES AND ADDITIONS TO THESE DRAWINGS MUST BE BROUGHT TO THE ATTENTION OF THE ENGINEER, WHEN NOTED AND BEFORE PROCEEDING WITH CONSTRUCTION WORKS. DO NOT CONTINUE CONSTRUCTION IN AREAS WHERE DISCREPANCIES APPEAR UNTIL SUCH DISCREPANCIES HAVE BEEN RESOLVED.
4. ALL ELEVATIONS ARE GEODETIC AND UTILIZE METRIC UNITS. ALL DIMENSIONS ARE IN METRES UNLESS OTHERWISE SPECIFIED. ALL DRAWINGS SHOULD NOT BE SCALED BY THE CONTRACTOR. ANY MISSING OR QUESTIONABLE DIMENSIONS ARE TO BE CONFIRMED WITH THE ENGINEER IN WRITING.
5. THE CONTRACTOR SHALL BE RESPONSIBLE FOR OBTAINING ALL PERMITS REQUIRED AND BEAR COST OF THE SAME.
6. CONTRACTOR SHALL BE RESPONSIBLE FOR ALL EXCAVATION, BACKFILL AND REINSTATEMENT OF ALL AREAS DISTURBED DURING CONSTRUCTION TO THE SATISFACTION OF THE ENGINEER, CITY OF OTTAWA AND THE AUTHORITY HAVING JURISDICTION.
7. ANY AREAS BEYOND THE LIMIT OF THE SITE DISTURBED DURING CONSTRUCTION SHALL BE RESTORED TO ORIGINAL CONDITION OR BETTER TO THE SATISFACTION OF THE AUTHORITY HAVING JURISDICTION AT THE CONTRACTOR'S EXPENSE.
8. THE CONTRACTOR SHALL COMPLY WITH CITY OF OTTAWA REQUIREMENTS FOR TRAFFIC CONTROL WHEN WORKING ON CITY STREETS. ALL CONSTRUCTION SIGNAGE MUST CONFORM TO THE M.T.O. MANUAL OF UNIFORM TRAFFIC CONTROL DEVICES (LATEST AMENDMENT).
9. THE SUPPORT OF ALL UTILITIES SHALL BE IN ACCORDANCE WITH THE REQUIREMENTS OF THE AUTHORITY HAVING JURISDICTION.
10. THERE WILL BE NO SUBSTITUTION OF MATERIALS UNLESS WRITTEN APPROVAL BY THE ENGINEER HAS BEEN OBTAINED.
11. EXCESS EXCAVATED MATERIAL SHALL BE REMOVED FROM THE SITE AS PER OPSS MUNI.180.
12. THE SITE LAYOUT IS THE RESPONSIBILITY OF THE CONTRACTOR. AS-BUILT SITE SERVICING & GRADING DRAWINGS SHALL BE MAINTAINED ON SITE BY THE CONTRACTOR.
13. THE CONTRACTOR WILL BE RESPONSIBLE FOR ADDITIONAL BEDDING OR ADDITIONAL STRENGTH PIPE IF THE MAXIMUM TRENCH WIDTH, AS SPECIFIED BY OPSD, IS EXCEEDED.
14. ALL NECESSARY CLEARING AND GRUBBING SHALL BE COMPLETED BY THE CONTRACTOR. REVIEW WITH ENGINEER AND THE CITY OF OTTAWA PRIOR TO ANY TREE CUTTING.
15. ALL EDGES OF DISTURBED PAVEMENT SHALL BE SAW CUT TO FORM A NEAT AND STRAIGHT LINE PRIOR TO PLACING NEW PAVEMENT. THE GRANULAR BASE COURSES AND ASPHALT LAYERS SHALL BE STEPPED AS PER DETAIL ON THIS DRAWING.
16. THE CONTRACTOR SHALL APPRAISE THEMSELVES OF ALL SURFACE AND SUBSURFACE CONDITIONS TO BE ENCOUNTERED AND SHALL CARRY OUT THEIR OWN TEST PIT'S AS REQUIRED TO MAKE THEIR OWN INDEPENDENT ASSESSMENT OF GROUND CONDITIONS. THE CONTRACTOR SHALL NOT MAKE ANY CLAIM FOR ANY EXTRA COST DUE TO ANY SUCH GROUND CONDITIONS VARYING FROM THOSE ANTICIPATED BY THE CONTRACTOR.
17. DO NOT CONSTRUCT USING DRAWINGS THAT ARE NOT MARKED "ISSUED FOR CONSTRUCTION".
18. CIVIL DRAWINGS TO BE READ IN CONJUNCTION WITH ARCHITECTURAL, LANDSCAPE AND LEGAL DRAWINGS.
19. ALL NECESSARY CLEARING AND GRUBBING SHALL BE COMPLETED BY THE CONTRACTOR. REVIEW WITH CONTRACT ADMINISTRATOR AND THE CITY OF OTTAWA PRIOR TO ANY TREE CUTTING.
20. ALL WORK TO BE DONE BY THE GENERAL CONTRACTOR UNLESS NOTED OTHERWISE.

GENERAL NOTES FOR GRADING:

1. IT SHALL BE THE BUILDER'S RESPONSIBILITY TO ENSURE THAT GRADING AROUND HYDRANTS, TRANSFORMERS, AND UTILITY PEDESTALS, ETC., MEET CURRENT CITY OF OTTAWA, HYDRO AND UTILITY COMPANY REQUIREMENTS.
2. ALL GROUND SURFACES SHALL BE EVENLY GRADED WITHOUT PONDING AREAS AND WITHOUT LOW POINTS EXCEPT WHERE APPROVED SWALE OR CATCH BASIN OUTLETS ARE PROVIDED.
3. CONTRACTOR TO ADJUST EXISTING CATCH BASINS, MANHOLES, FIRE HYDRANTS, VALVE CHAMBERS AND VALVE BOXES TO FINAL GRADE AS REQUIRED.

4. CONTRACTOR SHALL TAKE ALL NECESSARY PRECAUTIONS TO PROTECT EXISTING FOUNDATIONS OF ADJACENT BUILDINGS DURING EXCAVATION AND CONSTRUCTION PERIOD.
5. GRADING IN GRASSED AREAS WILL BE BETWEEN 2% TO 7%. GRADES IN EXCESS OF 7% WILL REQUIRE A MAXIMUM 3:1 TERRACING.

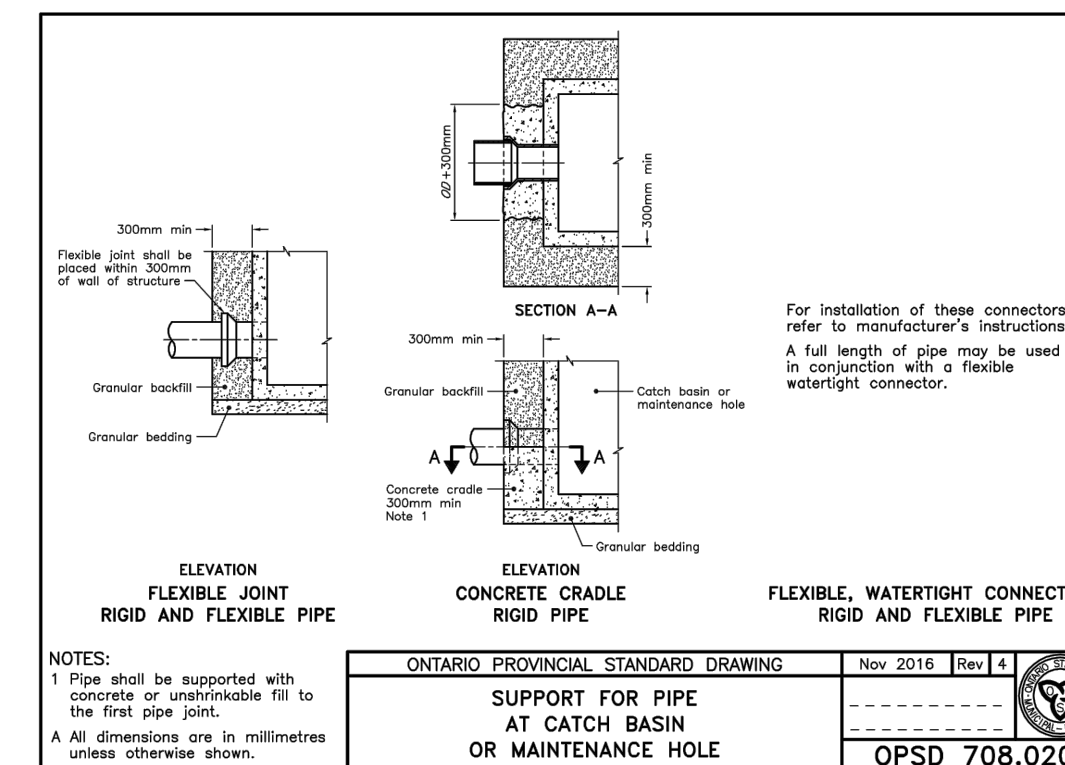
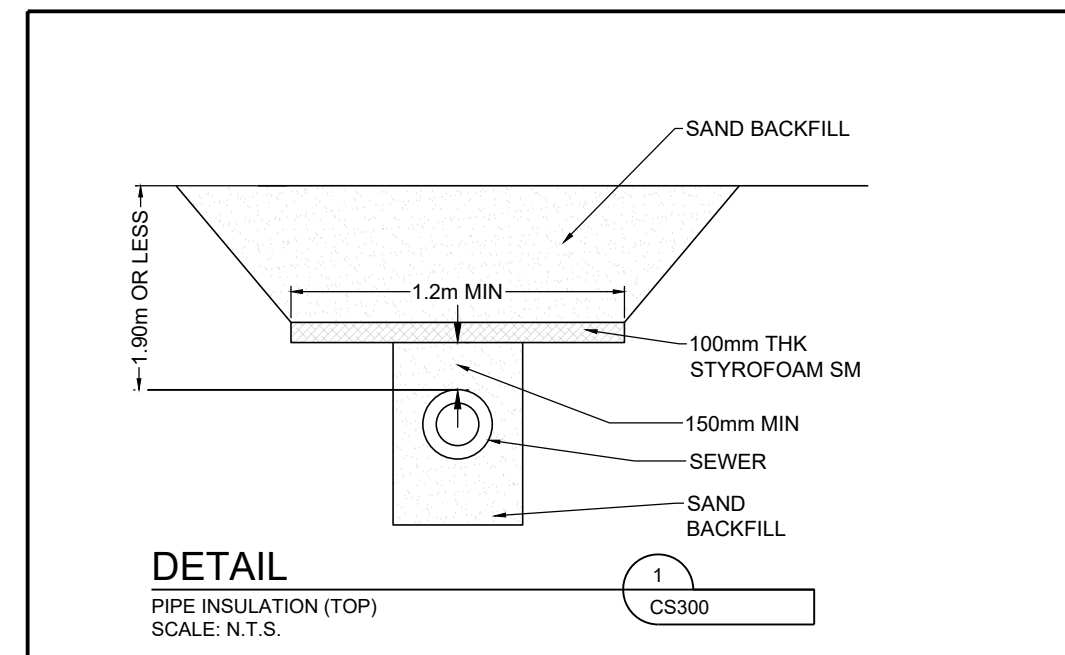

E:\BRM\BRM-23002042-W0160 Execution\01-30096-CS300-RC.dwg
12 May 2026

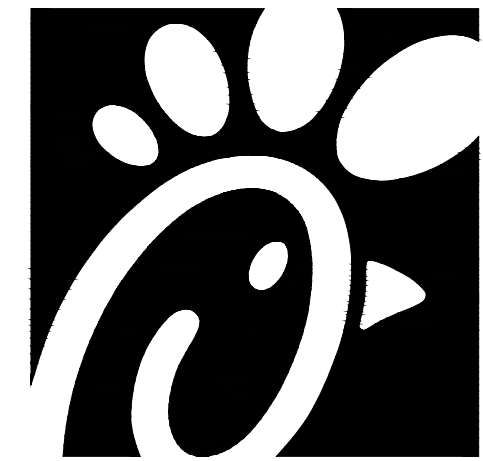

Chick-fil-A

Chick-fil-A
5200 Buffington Road
Atlanta, Georgia 30349-2998

exp Services Inc.
T: +1.905.793.9800 | F: +1.905.793.0641
1595 Clark Boulevard
Brampton, ON L6T 4V1
Canada

www.exp.com



- BUILDINGS • EARTH & ENVIRONMENT • ENERGY •
- INDUSTRIAL • INFRASTRUCTURE • SUSTAINABILITY •



CHICK-FIL-A
COLLEGE SQUARE

1984 Baseline Road
Ottawa, ON

FSR#30088

BUILDING TYPE / SIZE: IP02 SE
RELEASE:

NO.	DATE	DESCRIPTION
A	2025-09-17	ISSUED FOR UTILITY REVIEW
B	2025-09-23	ISSUED FOR SPA
C	2025-11-14	ISSUED FOR SPA
D	2026-05-25	AS PER CITY COMMENT

CONSULTANT PROJECT # BRM0023002042-W0
PROJECT STATUS SPA
DATE SEPTEMBER 2025
DRAWN BY J.K.

Information contained on this drawing and in all digital files produced for above named project may not be reproduced in any manner without express written or verbal consent from authorized project representatives.
SHEET
NOTES & DETAIL

SHEET NUMBER
CS300
FILE NUMBER D07-12-25-0159
PLAN NUMBER 19453

Issued for SPA