

4 3 2 1

WV CL ELEV=86.03 (REGIONAL ROAD 16)

WV CL ELEV=86.03

CHICK-FIL-A

ROAD ALLOWANCE BETWEEN CONCESSION 1 (RIDEAU FRONT) AND CONCESSION 2 (OTTAWA FRONT)

GENERAL NOTES:

- ALL ELEVATIONS ARE IN METRES, UNLESS NOTED OTHERWISE.
- ALL DIMENSIONS ARE IN MILLIMETRES, UNLESS NOTED OTHERWISE.
- DRAWING PRODUCED FROM J. D. BARNES LTD. DRAWING 25-10-063-00 DATED JULY 7, 2025. REFER TO SURVEY FOR BENCHMARK AND GEODETIC INFORMATION.
- ALL DIMENSIONS MUST BE VERIFIED BY THE GC PRIOR TO CONSTRUCTION. ANY DISCREPANCIES MUST BE BROUGHT TO THE ATTENTION OF CHICK-FIL-A'S REPRESENTATIVE.
- ALL WORK TO BE DONE BY THE GC UNLESS NOTED OTHERWISE.
- DRAWINGS ARE TO BE USED IN CONJUNCTION WITH SPECIFICATIONS.
- ALL WORK IS TO BE COMPLETED AS PER PROVINCIAL AND LOCAL REGULATIONS.
- EVERYTHING TO BE CONSIDERED NEW UNLESS NOTED OTHERWISE.
- MAKE GOOD ALL AREA'S DISTURBED DURING CONSTRUCTION.
- GC IS RESPONSIBLE FOR ALL LOCATES BEFORE CONSTRUCTION START.

LEGEND

- HW EX. HANDWELL
- BH EX. BOREHOLE
- SN EX. SIGN
- P EX. POST/BOLLARD
- EX. TELECOMMUNICATION MANHOLE
- EX. TELECOMMUNICATION CHAMBER
- EX. TELECOMMUNICATION MARK
- EX. SHRUB
- CONC EX. CONCRETE
- ELEV EX. ELEVATION
- CB EX. CATCH BASIN
- MH EX. MANHOLE
- SAN EX. SANITARY MANHOLE
- WH EX. WATER KEY
- WH EX. WATER HYDRANT
- HT EX. HYDRO JUNCTION BOX
- HT EX. HYDRO MAN HOLE
- HP EX. HYDRO POLE
- TC EX. TELEPHONE CHAMBER
- GLB EX. GROUND LEVEL BOX

PROPERTY LINE

- SILT FENCING
- SILT TRAP
- NEW CONCRETE CURB
- NEW CURB DEPRESSION
- NEW YARD LIGHT
- NEW STORM MH
- NEW SANITARY MH
- NEW STORM CB
- NEW STORM CBMH
- MAIN ENTRANCE
- ALTERNATE ENTRANCE
- LIGHT DUTY ASPHALT
- HEAVY DUTY CONCRETE
- LIGHT DUTY CONCRETE
- HEAVY DUTY ASPHALT
- INTERLOCKING PAVING STONES
- PONDING
- EX. ELEVATION
- MATCH EX. ELEVATION
- PROP. ELEVATION
- PROP. TOP OF CURB ELEVATION
- PROP. BOTTOM OF CURB ELEVATION
- PROP. SLOPE
- OVERLAND FLOW
- EX. CONTOUR LINE
- DEMOLITION

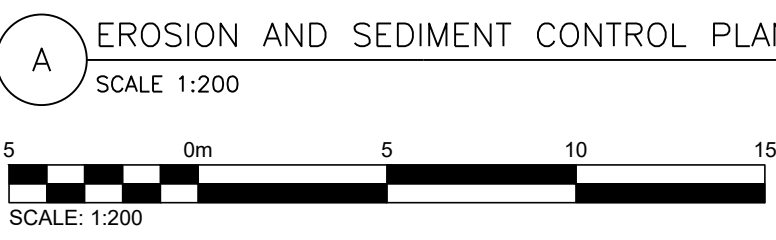
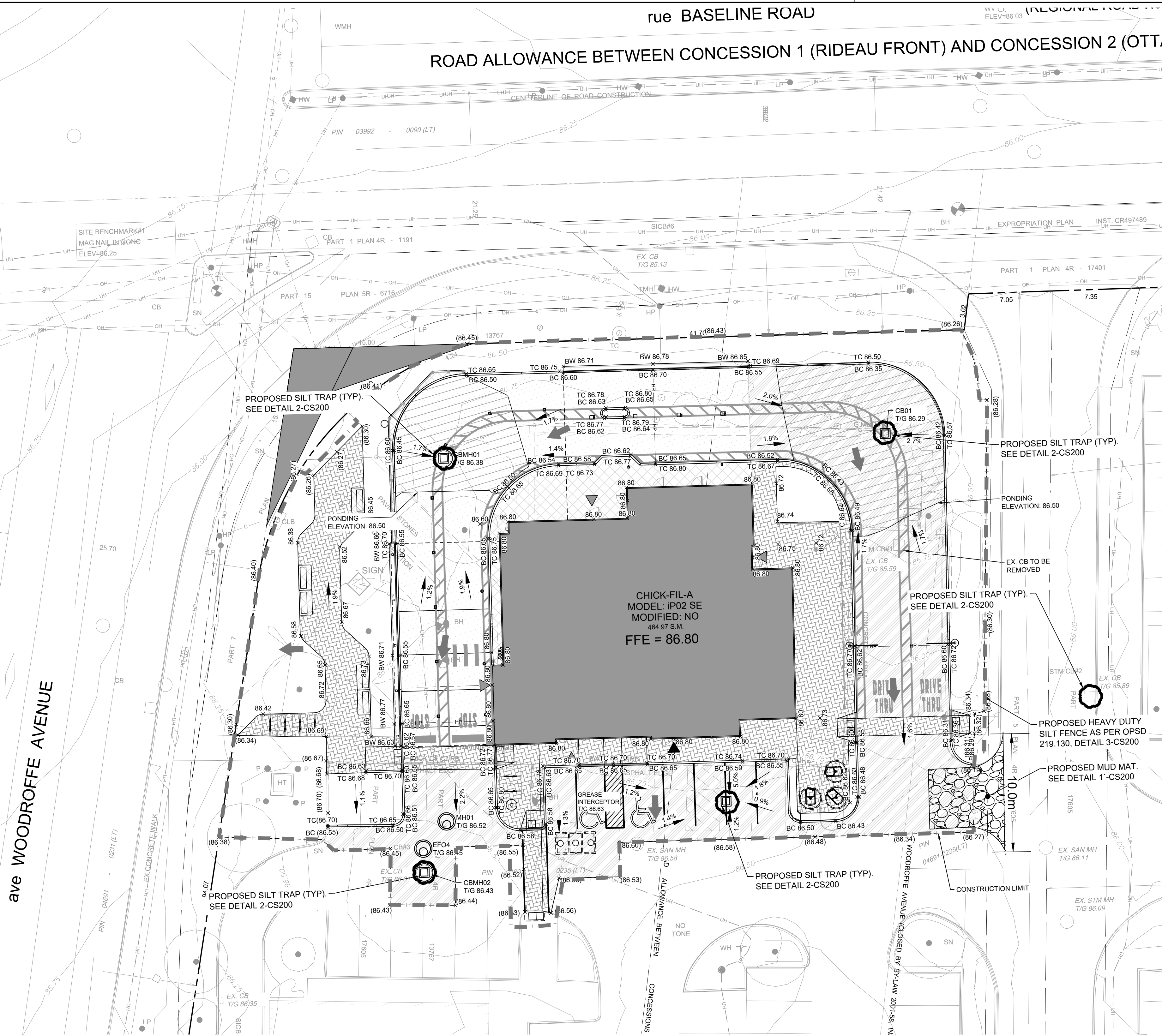
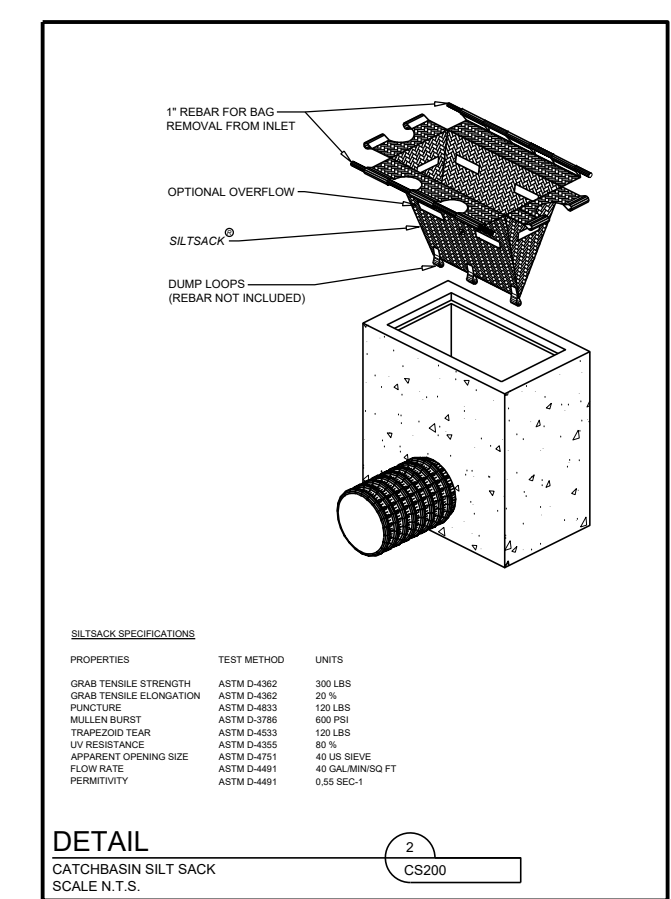
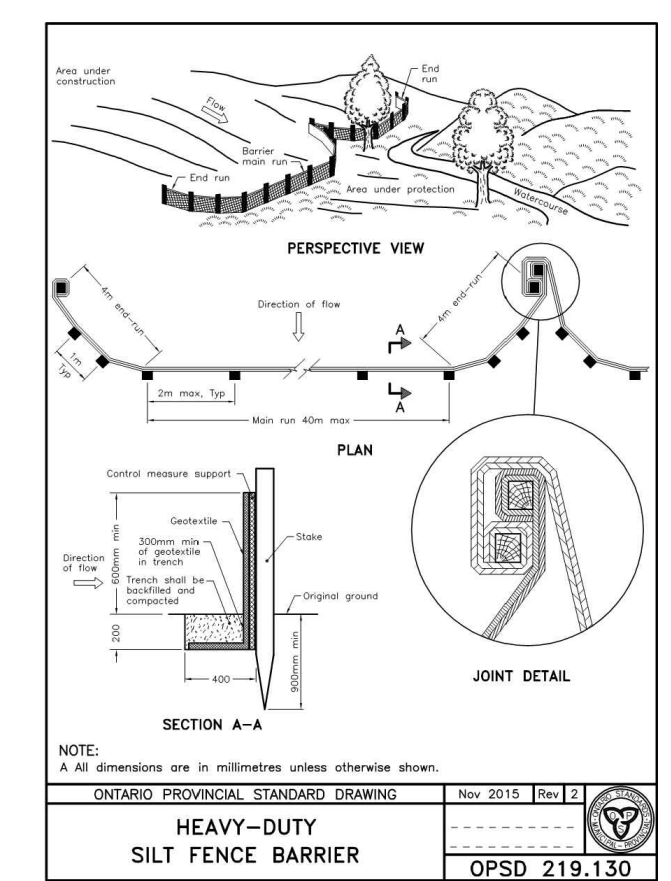
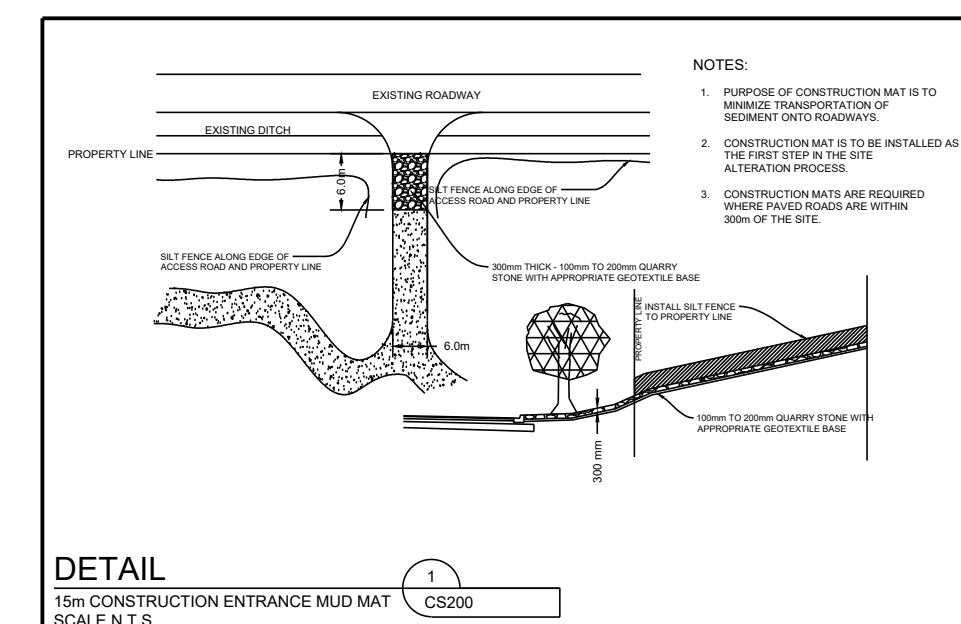

ESCC NOTES:

- THE CONTRACTOR SHALL ENDEAVOR TO PREVENT MUD TRACKING ONTO EXISTING RIGHTS-OF-WAY AND PROVIDE FOR CLEAN UP AT HIS OWN EXPENSE AS DIRECTED BY THE ENGINEER. THE CONTRACTOR SHALL ALSO BE RESPONSIBLE TO CONTROL DUST IN THE PROJECT AND HE SHALL PROVIDE, AT HIS OWN EXPENSE, CONTROLLING MEASURES AS DIRECTED BY THE ENGINEER AND THE CITY.
- ALL EXTERNAL AREAS DISTURBED DUE TO CONSTRUCTION SHALL BE RESTORED TO THEIR ORIGINAL CONDITION OR BETTER TO THE SATISFACTION OF THE CITY. PRIOR TO THE COMMENCEMENT OF SITE GRADING WORKS, ALL SILT CONTROL DEVICES SHALL BE INSTALLED AND OPERATIONAL. THE EXACT LOCATION TO BE DETERMINED IN THE FIELD AND APPROVED BY THE CITY OF OTTAWA. THE CONTRACTOR SHALL MAINTAIN ALL WORKS UNTIL SERVICING CONSTRUCTION IS COMPLETED TO THE SATISFACTION OF THE ENGINEER AND THE CITY OF OTTAWA.
- ALL EROSION AND SEDIMENT CONTROL MEASURES SHALL BE ROUTINELY INSPECTED AND MAINTAINED IN PROPER WORKING ORDER AND CLEANED PERIODICALLY AS REQUIRED BY THE COMMISSIONER OF ENGINEERING.
- ALL CONSTRUCTION VEHICLES SHALL EXIT THIS SITE VIA THE TEMPORARY CONSTRUCTION ACCESS.
- SILT CONTROL FENCE TO REMAIN IN PLACE UNTIL THE WORKING AREA HAS BEEN STABILIZED AND VEGETATED, TO THE SATISFACTION OF THE CITY OF OTTAWA.

- CONTRACTOR TO CLEAN ADJACENT ROADS ON A REGULAR BASIS OF THE SATISFACTION OF THE AFFECTED AUTHORITY.
- THE LOCATION AND ELEVATION OF ALL EXISTING SERVICES AND UTILITIES ARE TO BE VERIFIED IN THE FIELD BY THE CONTRACTOR AT THEIR EXPENSE. THE CONTRACTOR SHALL BE RESPONSIBLE FOR THE RESTORATION AND/ OR REPAIR OF EXISTING UTILITIES DISTURBED DURING CONSTRUCTION.
- ALL WORK SHALL BE COMPLETED IN ACCORDANCE WITH THE "OCCUPATIONAL HEALTH AND SAFETY ACT AND REGULATIONS FOR CONSTRUCTION PROJECTS" - THE GENERAL CONTRACTOR SHALL BE DESIGNATED AS THE CONTRACTOR AS IN THE ACT.
- IF ANY AREA OF THE SITE IS SCHEDULED TO REMAIN UNTOUCHED FOR THE MORE THAN 30 DAYS, IT SHOULD BE SEEDED IMMEDIATELY.
- ALL WORKS TO BE IN ACCORDANCE WITH THE CITY OF OTTAWA.
- THE EROSION AND SEDIMENT CONTROLS SHALL BE MODIFIED AS NECESSARY AND IN AN APPROPRIATE FASHION TO ENSURE ADEQUATE PROTECTION OF THE RECEIVING WATERCOURSE AND NATURAL HERITAGE SYSTEM.
- EROSION AND SEDIMENT CONTROLS WITHIN THE REGULATED AREA MUST BE INSTALLED, MAINTAINED AND REMOVED TO THE SATISFACTION OF CONSERVATION ALTON.
- ALL EROSION AND SEDIMENT CONTROLS ARE TO BE INSTALLED ACCORDING TO THE APPROVED PLANS PRIOR TO COMMENCEMENT OF ANY EARTH MOVING WORK ON THE SITE AND SHALL REMAIN IN PLACE UNTIL ALL DISTURBED AREAS

- ARE STABILIZED WITH THE INTENDED GROUND COVER.
- EROSION AND SEDIMENT CONTROLS SHALL BE INSPECTED BY THE BUILDER/DEVELOPER.
  - WEEKLY
  - BEFORE AND AFTER ANY PREDICTED RAINFALL EVENT.
  - FOLLOWING AN UNPREDICTED RAINFALL EVENT.
  - DAILY, DURING EXTENDED DURATION RAINFALL EVENTS.
  - AFTER SIGNIFICANT SNOW MELT EVENTS.
- EROSION AND SEDIMENT CONTROLS SHALL BE MAINTAINED IN PROPER WORKING ORDER AT ALL TIMES. DAMAGED OR CLOGGED DEVICES SHALL BE REPAIRED WITHIN 48 HOURS.
- WHERE A SITE REQUIRES DEWATERING AND WHERE THE EXPELLED WATER CAN BE FREELY RELEASED TO A SUITABLE RECEIVER, THE EXPELLED WATER SHALL BE TREATED TO CAPTURE SUSPENDED PARTICLES GREATER THAN 40 MICRON IN SIZE. THE CAPTURED SEDIMENT SHALL BE DISPOSED OF PROPERLY PER MOECC GUIDELINES. THE CLEAN EXPELLED WATER SHALL FREELY RELEASE TO A SUITABLE RECEIVER THAT DOES NOT CREATE DOWNSTREAM ISSUES INCLUDING BUT NOT LIMITED TO EROSION, FLOODING - NUISANCE OR OTHERWISE.
- EXISTING STORM SEWER AND DRAINAGE DITCHES ADJACENT TO THE WORKS SHALL BE PROTECTED AT ALL TIMES FROM THE ENTRY OF SEDIMENT/SILT THAT MAY MIGRATE FROM THE SITE. FOR STORM SEWERS: ALL INLETS (REAR LOT CB,

- ROAD CB, PIPE INLETS, ETC.) MUST BE SECURED/FITTED WITH SILT CONTROL MEASURES. FOR DRAINAGE DITCHES: THE INSTALLATION OF ROCK CHECK DAMS, SILT FENCE, SEDIMENT CONTAINMENT DEVICES SHALL BE INSPECTED AND MAINTAINED PER ITEMS 15 AND 16 ABOVE.
- IN THE EVENT OF A SPILL (RELEASE OF DELETERIOUS MATERIAL) ON OR EMANATING FROM THE SITE, THE OWNER OR OWNERS AGENT SHALL IMMEDIATELY NOTIFY THE MOECC AND FOLLOW ANY PRESCRIBED CLEAN UP PROCEDURE. THE OWNER OR OWNERS AGENT WILL ADDITIONALLY IMMEDIATELY NOTIFY THE CITY.
- IT IS CONTRACTOR'S RESPONSIBILITY TO MAINTAIN ADJACENT AND OFF-SITE ROADS FREE OF SEDIMENT DURING CONSTRUCTION. SILT SACK TO BE USED FOR EXISTING ADJACENT CB.



4 3 2 1



Chick-fil-A

Chick-fil-A  
5200 Buffington Road  
Atlanta, Georgia 30349-2998

exp Services Inc.  
T: +1.905.793.8800 | F: +1.905.793.0641  
1595 Clark Boulevard  
Brampton, ON L6T 4V1  
Canada  
www.exp.com

- BUILDINGS • EARTH & ENVIRONMENT • ENERGY •
- INDUSTRIAL • INFRASTRUCTURE • SUSTAINABILITY •



CHICK-FIL-A  
COLLEGE SQUARE

1984 Baseline Road  
Ottawa, ON

FSR#30088

BUILDING TYPE / SIZE: IP02 SE  
RELEASE:

REVISION SCHEDULE

NO.	DATE	DESCRIPTION
A	2025-09-17	ISSUED FOR UTILITY REVIEW
B	2025-09-23	ISSUED FOR SPA
C	2025-11-14	ISSUED FOR SPA
D	2026-05-25	AS PER CITY COMMENT

CONSULTANT PROJECT # BRM0023002042-WO  
PROJECT STATUS SPA  
DATE SEPTEMBER 2025  
DRAWN BY J.K.

Information contained on this drawing and in all digital files produced for above named project may not be reproduced in any manner without express written or verbal consent from authorized project representatives.

SHEET  
EROSION AND SEDIMENT CONTROL PLAN

SHEET NUMBER

CS200

FILE NUMBER 007-12-25-0159  
PLAN NUMBER 19453

E:\BRM\BRM-23002042-WO\60 Execution\65 Drawings\01-30096-CS200-RC.dwg  
22 May 2026