

## Engineering

- Land/Site Development
- Municipal Infrastructure
- Environmental/Water Resources
- Traffic/Transportation
- Recreational

## Planning

- Land/Site Development
- Planning Application Management
- Municipal Planning
- Urban Design
- Expert Witness (OLT)
- Wireless Industry

## Landscape Architecture

- Streetscapes & Public Amenities
- Open Space, Parks & Recreation
- Community & Residential
- Commercial & Institutional
- Environmental Restoration

## 541 SOMME STREET

### Serviceability and Stormwater Management Brief

**541 Somme Street  
City of Ottawa**

**Site Servicing and  
Stormwater Management Report**

Prepared By:

**NOVATECH**

Suite 200, 240 Michael Cowpland Drive  
Ottawa, Ontario  
K2M 1P6

June 03, 2025

September 23, 2025

February 06, 2026

March 13, 2026

**Revised: May 04, 2026**

Novatech File: 124111

Ref: F-2024-116

---

May 04, 2026

City of Ottawa  
Planning, Infrastructure and Economic Development Department  
110 Laurier Avenue West  
Ottawa, Ontario, K1P 1J1

Attention: Derek Kulyk, Project Manager

**Reference: 541 Somme Street  
Ottawa, ON  
Site Servicing and Stormwater Management Report  
Our File No.: 124111**

---

Enclosed is the revised 'Site Servicing and Stormwater Management Report' prepared for the proposed office and warehouse building located at 541 Somme Street in the City of Ottawa.

This report outlines the servicing and stormwater management design for the project and is submitted in support of a Site Plan Control application.

Please contact the undersigned should you have any questions or require additional information.

Yours truly,

**NOVATECH**



Greg MacDonald, P.Eng.  
Director, Land Development

# Table of Contents

<b>1.0</b>	<b>INTRODUCTION</b> .....	<b>1</b>
1.1	Location and Existing Site Description .....	1
1.2	Pre-Consultation Information .....	1
1.3	Proposed Development .....	1
1.4	Reference Material.....	2
1.5	Geotechnical Investigations .....	2
1.6	Approvals.....	3
<b>2.0</b>	<b>SITE GRADING AND SERVICING</b> .....	<b>3</b>
<b>3.0</b>	<b>SANITARY DISPOSAL</b> .....	<b>3</b>
3.1	Source Water Protection .....	4
<b>4.0</b>	<b>WATER SERVICING</b> .....	<b>4</b>
4.1	Domestic Water Supply .....	4
4.2	Fire Protection .....	4
<b>5.0</b>	<b>STORM DRAINAGE AND STORMWATER</b> .....	<b>6</b>
5.1	Stormwater Management Criteria and Objectives .....	6
5.2	Existing Conditions .....	6
5.3	Allowable Flows .....	7
5.4	Post-Development Conditions.....	7
5.4.1	<i>Summary of Post-Development Flows</i> .....	8
5.5	Stormwater Quality Control.....	8
5.6	Entrance Culverts and HGLs .....	10
<b>6.0</b>	<b>SITE GRADING</b> .....	<b>11</b>
6.1	Major System Overflow Route .....	11
<b>7.0</b>	<b>EROSION AND SEDIMENT CONTROL</b> .....	<b>11</b>
<b>8.0</b>	<b>CONCLUSIONS</b> .....	<b>12</b>
<b>9.0</b>	<b>CLOSURE</b> .....	<b>13</b>

## Appendices

- Appendix A: Pre-Consultation Correspondence
- Appendix B: Water Calculations
- Appendix C: Sanitary Design Information
- Appendix D: Stormwater Management Information
- Appendix E: Legal Plans

## List of Engineering Drawings

- 124111-ESC: Erosion and Sediment Control Plan
- 124111-GP: General Plan of Services
- 124111-GR: Grading Plan
- 124111-SWM-PRE: Pre-Storm Drainage Area Plan
- 124111-SWM-POST: Post-Storm Drainage Area Plan
- 124111-SRF: Surface Types Figure

## 1.0 INTRODUCTION

Novatech has been retained to prepare a Site Servicing and Stormwater Management Report for the proposed 541 Somme Street office/warehouse building and outdoor storage area, located on Somme Street within the Hawthorne Industrial Park in the City of Ottawa. This report provides the detailed design for the site servicing, storm drainage and stormwater management for the proposed site, in support of a Site Plan Application for the subject development.

### 1.1 Location and Existing Site Description

The site is located at 541 Somme Street and is legally described as Part 1 and 2, Part of Blocks 2 and Reserve Block 17, registered Plan 4M-1388. Refer to **Appendix E – Legal Plans** for a copy of the Plan of Survey by Annis, O’Sullivan, Vollebekk Ltd. The site location is also shown in **Figure 1 - Key Plan**.

The site is approximately 0.8 hectares (ha) in area and is currently vacant. The site is bordered by Somme Street to the west, the Hawthorne Industrial Park SWMF to the north, a vacant undeveloped lot to the south and a bedrock resource area to the east. The existing ground surface of most of the subject site is relatively flat. The site is zoned Rural Heavy Industrial (RH). **Figure 2 - Existing Conditions** shows the existing site conditions.

### 1.2 Pre-Consultation Information

A pre-consultation meeting was held with the City of Ottawa on July 05, 2024, at which time the client was advised of the general submission requirements. Refer to **Appendix A** for a summary of the correspondence related to the proposed development.

### 1.3 Proposed Development

The proposed development is intended to have a single building on site. The building will be a warehouse and office with a second floor mezzanine. A lean-to will project towards the south lot line. The total building footprint is 416.2 m<sup>2</sup> and the total gross floor area (GFA) of the proposed interior of the building is approximately 401.1 m<sup>2</sup>. The warehouse will be used to store Stormwater Management Products such as plastic parts, polymeric sand, and rolls of geotextile.

An asphalt surface parking lot is proposed in front of the building, with access to the site via two entrances from Somme Street. The back of the property will have a gravel surface used for outdoor storage and product deliveries.

Refer to **Figure 3 – Site Plan**.

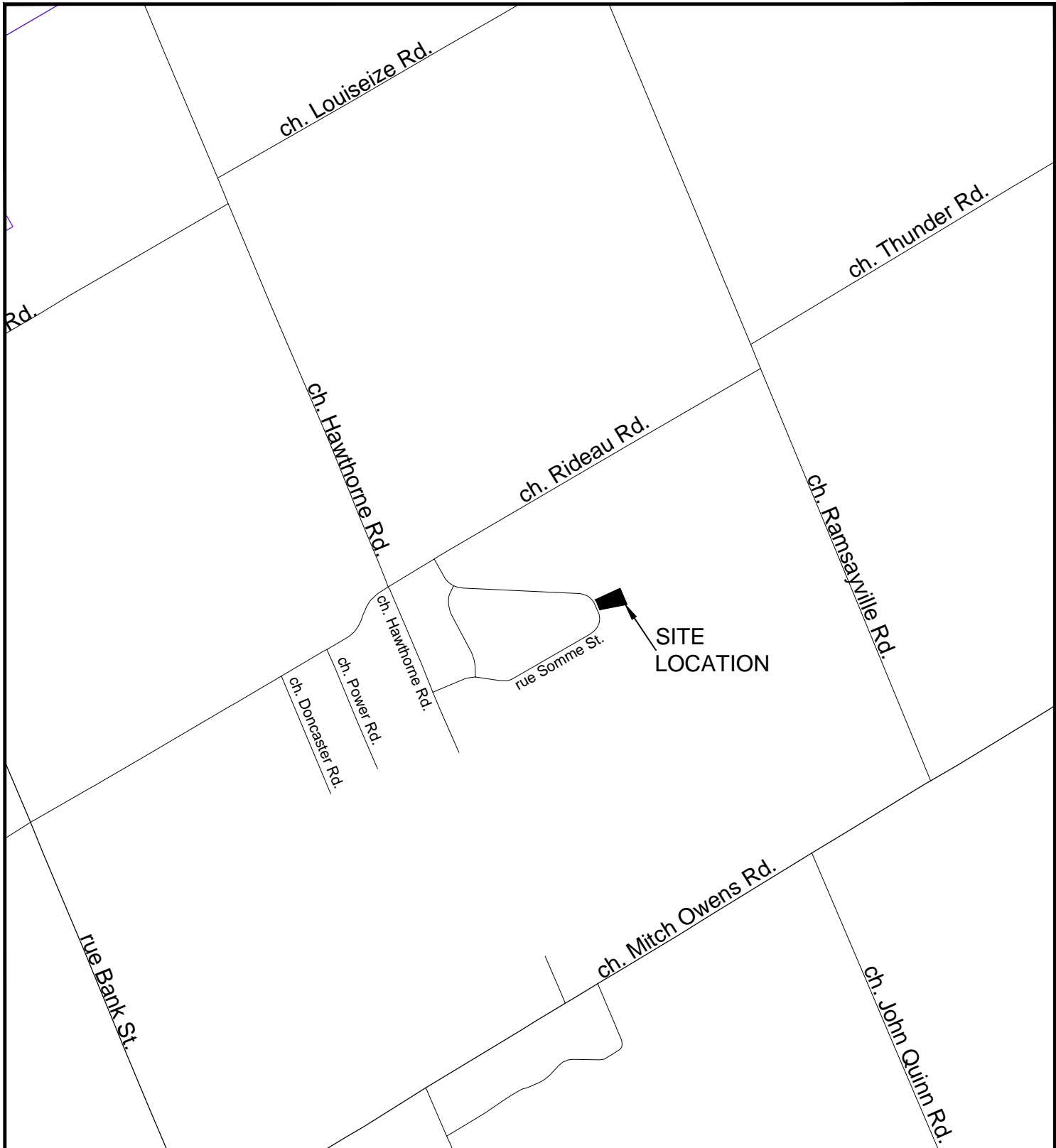

M:\2024\124111\CAD\Civil\Figures\124111-KP.dwg, KP, Oct 21, 2024 - 3:34pm, amusyaju



Engineers, Planners & Landscape Architects  
 Suite 200, 240 Michael Cowpland Drive  
 Ottawa, Ontario, Canada K2M 1P6

Telephone (613) 254-9643  
 Facsimile (613) 254-5867  
 Website [www.novatech-eng.com](http://www.novatech-eng.com)



CITY OF OTTAWA  
 541 SOMME STREET

KEY PLAN

SCALE		N.T.S	
DATE	JOB	FIGURE	
FEB 2025	124111	FIGURE 1	

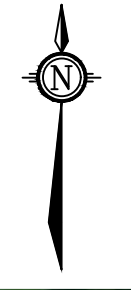

**LEGEND**

--- SITE BOUNDARY

**NOVATECH**

Engineers, Planners & Landscape Architects  
Suite 200, 240 Michael Cowpland Drive  
Ottawa, Ontario, Canada K2M 1P6

Telephone (613) 254-9643  
Facsimile (613) 254-5867  
Website www.novatech-eng.com

CITY OF OTTAWA  
541 SOMME STREET

**EXISTING CONDITIONS**

SCALE 1 : 1250

DATE FEB 2025 JOB 124111 FIGURE FIGURE 2

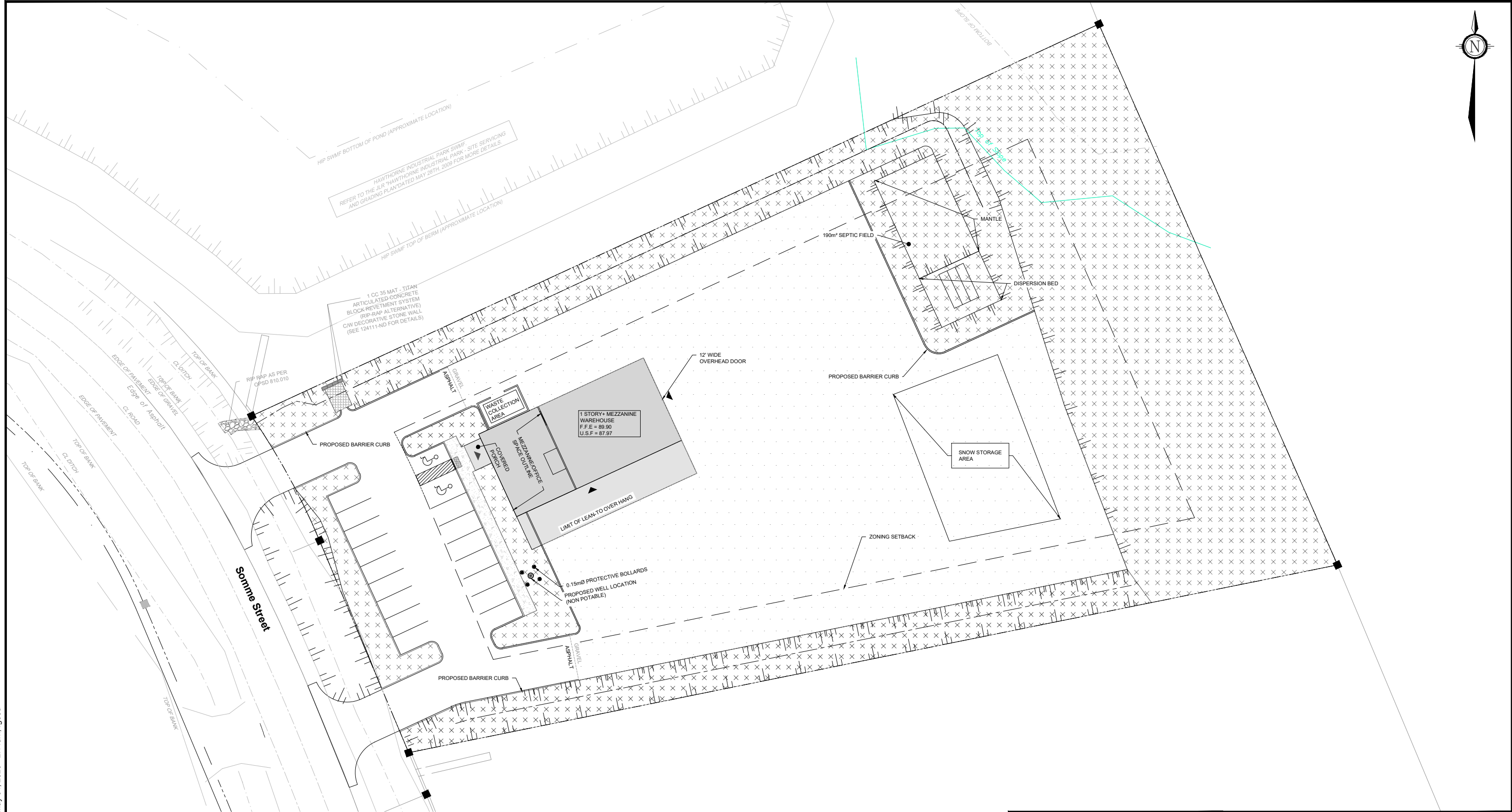

**LEGEND**

- SITE BOUNDARY
- BUILDING
- GRAVEL AREA
- 3:1 (MAX) TERRACING
- PROPOSED SWALE
- GRASS AREA

**NOVATECH**

Engineers, Planners & Landscape Architects  
 Suite 200, 240 Michael Cowpland Drive  
 Ottawa, Ontario, Canada K2M 1P6

Telephone (613) 254-9643  
 Facsimile (613) 254-5867  
 Website www.novatech-eng.com

CITY OF OTTAWA  
 541 SOMME STREET

**SITE PLAN**

SCALE 1 : 500

DATE MAY 2026 JOB 124111 FIGURE 3

M:\2024\124111\CAD\_LBase\124111-BP.dwg, SP, May 04, 2026 - 2:11am, rgood

## 1.4 Reference Material

The following material has been reviewed.

- 1 “Geotechnical Investigation Proposed Commercial Storage Building, 541 Somme Street, Ottawa, Ontario” report (PG7327-1), prepared by Paterson Group Inc., dated August 21, 2025.
- 2 “Hydrogeological Assessment and Terrain Analysis, Proposed Commercial Development, 541 Somme Street, Ottawa, Ontario” report (PH4991-LET.02REV.01 - HATA), prepared by Paterson Group Inc., dated August 01, 2025.
- 3 “Stormwater Management Report Hawthorne Industrial Park”, report (JLR 20983), prepared by J.L. Richards & Associates Limited, dated May 2009.
- 4 “Shields Creek Subwatershed Study”, prepared by City of Ottawa, dated June 2004.

## 1.5 Geotechnical Investigations

A geotechnical investigation was completed for the proposed development, and a report prepared entitled “Geotechnical Investigation Proposed Commercial Storage Building, 541 Somme Street, Ottawa, Ontario” report (PG7327-1), by Paterson Group Inc. dated November 25, 2024. The following is a summary of the findings of the report:

- Boreholes were advanced to practical refusal; depths ranged from 0.86m to 1.27m, and groundwater was not observed at the time of the investigation. It should be noted that groundwater levels are subject to seasonal fluctuations and groundwater levels could vary at the time of construction.
- The on-site soil testing suggests the subsurface profile generally consists of imported fill material which varies from 0.61m to 1.30m in thickness. The fill was generally observed to consist of loose to compact, grey to brown silty sand to sandy silt with occasional traces of topsoil and gravel.
- The subsoil at this site is mainly Type 2 and 3 soil according to the Occupational Health and Safety Act and Regulations for Construction Projects. Excavation side slopes above the groundwater level extending to a maximum depth of 3 m should be cut back at 1H:1V or flatter. The flatter slope is required for excavation below groundwater level.
- It is anticipated that groundwater infiltration into the excavations should be low to moderate and controllable using open sumps.
- The Ministry of the Environment, Conservation and Parks (MECP) stipulate the requirements for Permit to Take Water (PTTW) approvals for construction related activities. Under the requirements, specific construction related water taking activities are eligible for Environmental Activity and Sector Registry (EASR). The trigger volume for EASR is water taking more than 50,000 litres/day. Volumes beyond 400,000 litres/day will require the application of a PTTW.
- As the proposed building does not contain below grade space, and the subsurface conditions consist of relatively shallow bedrock, foundation drainage is not required.

## 1.6 Approvals

The proposed stormwater conveyance and stormwater management design will require approval from the City of Ottawa and the South Nation Conservation Authority (SNCA).

The Ministry of the Environment, Conservation and Parks (MECP) were consulted to confirm the appropriate Environmental Approval process for the development based on the specific site criteria. They confirmed that once the site's Stormwater Management Design has received Municipal Approval, the relevant documents will need to be registered under the Industrial Stormwater Management Environmental Activity and Sector Registry (EASR). Refer to **Appendix D** for a copy of the correspondence.

The proposed septic system design will require approval from the Ottawa Septic System Office (OSSO).

## 2.0 SITE GRADING AND SERVICING

The objective of the site servicing design is to conform to the requirements of the City of Ottawa, to provide suitable sewage outlets and to ensure that a water supply and appropriate fire protection are provided for the proposed development.

Since there are no municipal services available on Somme Street, it is proposed to service the proposed building with a drilled well and septic system.

The site will be graded to facilitate stormwater drainage towards two perimeter swales via overland flow. Stormwater runoff from the proposed perimeter swales will be captured by storm drainage structures and conveyed by pipe networks to an Oil Grit Separator unit at the northwest property line, before discharging to the existing Somme Street roadside ditch.

## 3.0 SANITARY DISPOSAL

The proposed building will be serviced by an individual sewage disposal system (septic system). The septic system location is shown on the Grading and Servicing plans and is proposed to be a tertiary system, complete with a fully raised (Class IV) tile field.

The design flow was calculated based on the Ontario Building Code (OBC) – Code and Guide for Sewage Systems, 2020 - Part 8 - Section 8.2 and the building information on the architectural drawings. Refer to **Appendix C – Sanitary Design Information** for excerpts from the OBC:

Activity	Application	Flow	Total Flow (L/day)
Office Staff + Building Visitors	5 (max)	75L per person	375
Warehouse	1 Water Closet 1 Loading Bay	950L per Water Closet 150L Per loading bay	950+150
<b>Total</b>			<b>1,475</b>

The maximum theoretical design flow based on the above scenario is 1,475 L/day.

The warehouse component of the building is required to have a floor drain (complete with an OGS unit). No vehicle washing or water use is intended within the warehouse. The floor drain is in place for emergency purposes (spills, snow melt, etc.) and does not introduce additional flows to those accounted for in the 1,100L/day from the warehouse. The floor drain flows will be conveyed to the sanitary service lateral and onto the septic tanks and then the septic field.

### 3.1 Source Water Protection

The site is located within the South Nation Source Protection Area and is not situated in Significant Groundwater Recharge Area, Wellhead Protection Area, or an Intake Protection Zone. However, it is located within a Highly Vulnerable Aquifer (HVA) with a Vulnerability Score of 6. Refer to Appendix A for a copy of the MECP Source Protection Information Atlas output for the proposed development's location.

The private on-site septic system can present a threat to the HVA and therefore mitigation measures will be implemented in accordance with the development's Hydrogeological report prepared by Paterson Group (Report # PH4991-LET.02). The recommended mitigating measures include locating the sewage system a minimum of 30m from the water supply well and lining the sewage system with a 100mm clay seal.

## 4.0 WATER SERVICING

### 4.1 Domestic Water Supply

The domestic water demand for the development is equal to the sanitary demand (1,005L/day) in Section 3.0. The building will be serviced by a new drilled well; the approximate location of the well is shown on the General Plan of Services (124111-GP).

Paterson Group has conducted water testing on the proposed well to verify water quantity and quality for the domestic usage. The results demonstrated that the test well has a high yield to support the quantity demand; however, the quality results indicated the well supply cannot be used for drinking water and can only be used for non-potable uses. Paterson held discussions with the City of Ottawa's Hydrogeology Team and confirmed the City would accept the well supply to be used for non-potable site use. Refer to **Appendix B** for a copy of the correspondence and refer to the Hydrogeological Report by Paterson for further details.

Potable water will be brought to site and provided for staff and site visitor consumption. Non-Potable Water Signage shall be provided at all water supply taps at the proposed building. The signage shall be consistent with the Ontario Building Code requirements.

### 4.2 Fire Protection

The following requirements for assessing the site's fire flow were defined in the pre-consultation with the City of Ottawa:

- It is the responsibility of the Owner to ensure that an adequate water supply for firefighting is provided.
- Structures with a footprint of less than 600m<sup>2</sup>, and not containing medium/high hazard occupancy, can proceed with OBC method for determining fire flows. Otherwise, the FUS in conjunction with the NFPA 1142 methodologies will need to be considered and the Ottawa Fire Services support of the proposed finding will be required.

- Enhanced review will be invoked, should the construction coefficient be chosen less than 1. The total effective floor area needs to be carefully considered. The applicant can contact Allan Evans with the Ottawa Fire Services to discuss operational issues.
- If FUS calculations are required, and the demands/water storage requirements are significant, the applicable costs will not be an acceptable cause for deviation from the requirements.
- Fire routes need to be designated through the site plan process.

The following building design specifications were provided on Elevate Home Design's plans and were utilized in the fire flow calculations and design approach:

- The building has a footprint of 416.2m<sup>2</sup>
- The Major Occupancy Classification is "Group F, Division 3 – Low Hazard Industrial."
  - Combustible content, stored inside, shall not be more than 50kg/m<sup>2</sup> or 1,200 MJ/m<sup>2</sup> of floor area.
- No sprinklers are proposed.

Refer to **Appendix B** for a copy of the building design drawings.

In accordance with the pre-consultation minutes, and the applicable building design provided by Elevate, the fire flow has been assessed based on the OBC; the required Minimum Water Supply Flow Rate is 2,700L/minute. Refer to **Appendix B** for a copy of the OBC Water Supply for Firefighting Calculations.

As the proposed building is less than 600 m<sup>2</sup>, and combustible content will either be stored outside or in quantities not more than 50kg/m<sup>2</sup> (as outlined in OBC for "Low-hazard industrial occupancy – Group F, Division 3"), on-site fire storage tanks should not be required. In addition, it is suggested that the building be provided with a fully monitored fire alarm system which will notify the Ottawa Fire Services (OFS) immediately upon triggering of the alarm.

City of Ottawa Fire Services was consulted on the above approach. Refer to **Appendix B** for a copy of the correspondence.

The OFS also noted that the ultimate determination for the need of an on-site water supply will be at discretion of the City of Ottawa's Building Code Services during the Building Permit process.

## 5.0 STORM DRAINAGE AND STORMWATER

### 5.1 Stormwater Management Criteria and Objectives

The site is located within the Hawthorne Industrial Subdivision. Thus, the Hawthorne Industrial Park Stormwater Management (SWM) Report <sup>2</sup> prepared by J.L. Richards & Associates was consulted for the applicable stormwater management criteria.

The subject site is located within the catchment area of the stormwater management facility (SWMF) designed and constructed for the Hawthorne Industrial Park. This SWMF is a dry pond, designed to provide water quantity control for all sites within its catchment area assuming 70% site imperviousness.

Based on the Hawthorne Industrial Park SWM Report <sup>2</sup> and the current City of Ottawa Sewer Guidelines, the stormwater management criteria and objectives for the site are as follows:

- Stormwater quantity control is provided in the existing downstream dry pond for storms up to and including the 100-year storm event. Should the runoff coefficient of the entire site exceed 0.70 then individual sites shall provide storage to attenuate post-development peak flows to the equivalent runoff coefficient of 0.70.
- To provide post-development erosion control the Hawthorne Industrial Park's 2-year post development flow should be controlled to 50% of the 2-year pre-development peak flow rate. This control is provided by the Hawthorne Industrial Park's dry pond. Refer to **Appendix D** for excerpts from the report.
- Design the storm drainage system to convey post-development flows for all storms up-to and including the 100-year storm event.
- Provide an on-site oil/grit separator to achieve a *normal* level of stormwater quality treatment (corresponding to 80% long term removal of total suspended solids (TSS)) for all flows to the roadside drainage ditch system.
- Provide guidelines to ensure that site preparation and construction is in accordance with the current Best Management Practices for Erosion and Sediment Control.
- There are no specific water balance and infiltration requirements for the site due to existing site conditions.

### 5.2 Existing Conditions

Under existing conditions, the 0.8 ha site is undeveloped. As per the Hawthorne Industrial Park SWM Report <sup>2</sup>, the site has previously been used to dispose of fill materials resulting from construction activities. As such, the existing condition of the site does not represent typical 'pre-development' conditions. Due to presence of fill, we have used a runoff coefficient of 0.25 for the site.

Stormwater flows from the site currently drain either to the existing Somme Street roadside storm drainage ditch or to the eastern and southern sides of the site.

### 5.3 Allowable Flows

The quantity control criteria for the subject site are to control post-development flows from the site to the allowable flows per the JL Richards report prepared for the industrial subdivision for all storm events up to and including the 100-year design event. The allowable flows correspond to an overall Rational Method runoff coefficient ( $C_w$ ) of 0.70 for the subject site. The City's current requirement to consider the 1:100-year (plus 25%) was reviewed and used to calculate the 100-year design flows for on-site stormwater infrastructure sizing.

The weighted runoff coefficient was calculated as follows:

**Table 2: Runoff Coefficient**

Surface Types	Area (ha)	Runoff Coefficient
Building	0.043	1.00
Asphalt Parking	0.085	0.90
Gravel Surface	0.320	0.70
Grass	0.354	0.25
<b>Total</b>	<b>0.801</b>	<b><math>C_w = 0.54</math></b>

As the proposed Runoff Coefficient does not exceed 0.70, no additional stormwater quantity control is required. Refer to **Appendix D** for a plan showing the Surface Types (124111- SRF) and runoff coefficient calculations.

### 5.4 Post-Development Conditions

The proposed storm drainage system will consist of grass swales along the perimeter of the lot, landscape drains and catch basin manholes located in the swales, and a catch basin in the paved parking area. The flow collected in the stormwater system will be conveyed to the OGS unit located at the northwest property corner, before discharging to the municipal ditch system.

During heavy rainfall events, excess flow will be directed to the roadside ditch and the Hawthorne SWMF, via the overland flow routes defined in the grassed swales. The spillways will be used for storm events which exceed the on-site storm system's capacity. The naturalized area at the back of the property will drain as it does under pre-development conditions. Refer to the Grading Plan(124111-GR) and the Post Storm Water Management Plan (124111-SWM-POST) for details.

The proposed development will consist of six (6) main drainage sub-catchment areas. A brief description of these areas is as follows:

- D-01: Direct Runoff Areas - Runoff from the treed and grassed area at the rear of the property will flow as per existing drainage pattern.
- D-02, D-03: Direct Runoff Area -Runoff from the grass areas at front of the property will flow freely towards the existing the Somme Street roadside ditch as per existing drainage patterns.
- A-01: Uncontrolled Runoff Area - Runoff from the south side of the building, including half of the building roof and its overhang will drain to the southern perimeter swale, via overland flow.

- A-02: Uncontrolled Runoff Area - Runoff from the north side of the building, including half of the building roof will drain to the northern perimeter swale, via overland flow.
- A-03: Uncontrolled Runoff Area- Runoff from the area in front of the building will be drained towards the catch basin located at the parking lot.

As recommended in the Geotechnical Investigation Report prepared by Paterson Group and dated August 21, 2025, no foundation drain is required for the proposed building. Please refer to **Appendix D** for an excerpt of the geotechnical report's foundation drain recommendation.

#### 5.4.1 Summary of Post-Development Flows

The post-development flows from the site for the 2-year, 5-year, and 100-year design events were calculated using the Rational Method. Table 5.4-A summarizes the total post-development flows from the site; refer to **Appendix D** for detailed SWM calculations

**Table 5.4-A: Stormwater Flow Summary Table**

Design Event	Allowable Development Flows (L/s)*	Post-Development Flows						Total Site Flow (L/s)
		D-01 (L/s)	D-02 (L/s)	D-03 (L/s)	A-01 (L/s)	A-02 (L/s)	A-03 (L/s)	
2-Year	119.8	9.7	0.1	0.1	39.8	31.0	11.3	92.0
5-Year	162.5	13.1	0.1	0.1	53.9	42.0	15.3	124.5
100-Year	278.5	28.1	0.1	0.3	111.6	85.3	26.8	252.2

\* Allowable flows based on the JLR Report and an assumed coefficient of 0.70

Based on Manning's Equation, a 375mm dia. gravity storm sewer at a minimum slope of 0.4% has a full flow conveyance capacity of approximately 115.7 L/s, which is sufficient to convey the typical storm events. In more significant events, the pipe will surcharge and spill overland to the ditch fronting the development.

The post-development flows are less than the allowable flows for the site for the 2-year, 5-year, and 100-year design storm events.

#### 5.5 Stormwater Quality Control

The Hawthorne Industrial Park SWM Report <sup>2</sup> indicates the subject site requires a *normal* level of stormwater quality treatment (70% long-term TSS removal) provided using an oil/grit separator unit. However, since the report was issued, the City has changed the water quality criteria to the enhanced level treatment. As requested within the pre-consultation minutes, the site will be designed to meet the improved 80% TSS removal criteria. This will be achieved with an on-site OGS unit, and an upstream treatment train approach.

### 5.5.1 OGS Unit Details

Rinker Materials was retained to model and analyze the tributary area and provide an OGS unit capable of meeting the TSS removal requirements. As a result, a 1200mm diameter EFO4 Stormceptor unit has been included in the Civil design at the Stormwater outlet location from the site. The following are key details regarding the unit's specifications which can also be found within the supplier's product details found in **Appendix D**:

- Sediment Storage Capacity = 1,190 L
- Oil Storage Capacity = 265 L
- Sediment Maintenance Depth = 203mm
- Maximum Treatment Flow Rate = 10.4 L/s
- Maximum Conveyance Flow Rate = 425 L/s

### 5.5.2 Tailwater Impacts on OGS Unit

The design of the proposed OGS unit has been adjusted to ensure that it will meet the performance targets in the event of elevated tailwater elevations in the Somme Street outlet ditch. Under normal operating conditions, flows up to 10.4 L/s are routed through the settling chamber using a bypass weir with a crest elevation set 0.28m above the inlet to the settling chamber. During larger storm events, the outlet from the OGS will be partially submerged due to backwater from the SWM facility.

To address potential impacts on the performance of the OGS unit, the crest elevation of the bypass weir has been raised to be 0.28m above the 2-year water level in the outlet ditch to ensure that there is no reduction in the treatment capacity of the unit.

2yr Water Level in Somme Street Ditch:	88.23m
Design Head required for OGS treatment:	0.28m
OGS Unit Bypass Weir Crest Elevation:	$88.23\text{m} + 0.28\text{m} = 88.51\text{m}$

The increase in weir height will ensure that the maximum treatment flow rate of 10.4 L/s can still be routed through settling chamber even under elevated tailwater conditions. The increased height of the bypass weir will increase the maximum treatment flow rate through the settling chamber to approximately 15 L/s under normal (no tailwater) conditions.

There will be minimal to no backflow into the OGS unit, even during large storm events. The water levels in the on-site storm sewers and the upstream ditches both on-site and within the Somme Street ditch may periodically rise above the invert of the OGS unit outlet pipe, but water levels in the ditches will rise more quickly than the water levels in the SWMF as the flows from the subject site and other sites within the industrial park are what contributes to the water levels in the SWMF. As such, the slope of the HGL and the flow of water from the site will continually be towards the SWMF and there should be no significant backflow through the OGS unit. The water levels on site and in the downstream ditches will draw down at the same time as the SWMF but will never be lower than the water levels in the SWMF.

The design has been reviewed to ensure that the increase to the on-site HGL will not have any adverse impacts on the proposed storm drainage design. Drainage from the site is initially collected by perimeter swales which inlet to the storm sewers and therefore there will be no backwater impacts on building services.

### 5.5.3 OGS Unit Operation and Maintenance

To ensure the OGS continues to function properly, regular inspection and maintenance is required. A copy of the Stormceptor Owners Manual is included in Appendix D; the recommended inspection and maintenance requirements are provided within that document and summarized below:

- A post-construction inspection of the unit is required prior to putting it into service.
- The Stormceptor shall be inspected every month during the first year to assess the sediment accumulation. The duration of time to reach the sediment maintenance depth (203mm) shall be recorded.
- An annual inspection and maintenance schedule is to be prepared based on the results observed during the first year of operation. Once established, that schedule is to be registered on the Ministry of Environment EASR in addition to this report.

Inspection of the unit should be performed immediately after an oil, fuel, or chemical spill.

Upstream of the OGS unit, the grassed swales are designed with the following features to further promote sediment removal:

- The storm drain top of grates are raised 5cm above the bottom of swale.
- The swales will include a sand filtering layer, perforated subdrain surrounded in clear stone, and a geotextile fabric.

### 5.6 Entrance Culverts and HGLs

The entrance driveway culverts are required to convey the Hawthorne Industrial Park's (HIP) upstream stormwater flows, for the 10-year storm event, without overtopping the driveways. This design criterion was established in the JL Richards SWM Report and is consistent with the MTO - Highway Drainage Design Standards (January 2008).

The JL Richards report calculated the ditch flow (10-year) directly downstream of the 541 Somme Street location, which included the flow from 541 Somme Street, to be 1,310 L/s. The proposed entrance culverts for the 541 Somme Street development are dual 700mm diameter CSP and have been sized utilizing culvert sizing nomographs from the MTO Drainage Management Manual to convey this flow.

The flows and corresponding water elevations in the ditch fronting 541 Somme Street have been calculated for the 2, 5, 10, and 100-year storm events:

- The 10-year and 100-year peak flows have been taken directly from the JLR SWM Report.
- The 2-year and 5-year flows were calculated using the Rational Method using the same Time of Concentration and 2.78AR value as the 10-year event (which will provide conservative results for the more frequent storm events).

The flows and water elevations are summarized in **Table 5.4-B**.

**Table 5.4-B: Somme Street Ditch – Design Flow and Water Levels Table**

Design Event	Flow (L/s)	HGL
2-Year	833.7	88.23
5-Year	1,121.3	88.28
10-year*	1,310.1*	88.30
100-Year*	3,059.5*	88.54

\*Value provided in JLR Hawthorne Industrial Park SWM Report

Refer to **Appendix D** for a copy of the JL Richards Storm Drawing (D-ST1), the 1:10yr & 1:100yr Storm Design Sheet, the MTO Design Standards excerpts, and the approximated ditch flow calculations.

## 6.0 SITE GRADING

Most of existing site is generally flat at elevations between approximately  $\pm 88.8\text{m}$  and  $\pm 90.4\text{m}$ . The bottom of ditch elevation of the existing storm drainage ditch along Somme Street on the western side of the site is approximately  $\pm 87.8\text{m}$  to  $\pm 88.3\text{m}$ . Refer to plan **124111-GR** for details.

The proposed stormwater outlet has been set at an invert level of 87.95m. This is based on providing 0.15m clearance above the existing storm drainage ditch.

### 6.1 Major System Overflow Route

In the case of a major rainfall event exceeding the design storms, stormwater from the proposed development will overflow towards the existing storm drainage ditch along Somme Street and towards the Hawthorne Industrial Park's SWMF. The finished floor elevation (FFE) of the proposed building has been set to be a minimum of 0.3m above the major system overflow points. The major system spill points are shown on plan **124111-GR**.

## 7.0 EROSION AND SEDIMENT CONTROL

To mitigate erosion and to prevent sediment from entering the municipal drainage system, temporary erosion and sediment control measures will be implemented on-site during construction in accordance with the Best Management Practices for Erosion and Sediment Control. This includes the following temporary measures:

- Silt fencing will be placed per OPSS 577 and OPSD 219.110 along the surrounding construction limits, where applicable.
- Filter socks will be placed under the grates of the ditch inlet catch basins and swale catch basins and will remain in place until construction is completed.
- Light duty straw bales will be placed at key locations in the swales;
- Mud mats will be installed at the site entrances.

- Street sweeping and cleaning will be performed, as required, to suppress dust and to provide safe and clean roadways adjacent to the construction site.
- On-site dewatering is to be directed to a sediment trap and/or gravel splash pad and discharged safely to an approved outlet as directed by the engineer.

The temporary erosion and sediment control measures will be implemented prior to construction and will remain in place during all phases of construction. Regular inspection and maintenance of the erosion control measures will be undertaken.

## 8.0 CONCLUSIONS

This report has been prepared in support of a site plan control application for the proposed 541 Somme Street in the City of Ottawa.

The conclusions are as follows:

- The proposed development is intended to be an office / warehouse building with a total gross floor area (GFA) of approximately 401.1 m<sup>2</sup>.
- A new drilled well will supply the site with water for non-potable use (such as hand washing and toilets), potable water will be brought to site and supplied via water supply/refill stations.
- Water for fire protection will not be stored onsite since the building is less than 600m<sup>2</sup> and is classified as Low hazardous Industrial occupancy as per the OBC. A monitored fire alarm system will be included for immediate notification of a fire event to the Ottawa Fire Services department.
  - The City of Ottawa Building Code Services will make the final determination if onsite water supply for fire fighting is required during the Building Permit process.
- The proposed septic system is based on a design flow of 1,475 L/day and will be treated with a Tertiary Septic system and Class IV septic field. A Sewage System Permit application will be required from the Ottawa Septic System Office.
- Storm drainage will be provided via overland flow draining to a grassed perimeter swale.
- On-site quantity control of storm runoff prior to discharge into the Somme Street roadside drainage ditch system is not required as the total post-development flows from the site are less than the allowable release rates for the site. The Hawthorne Industrial Park end-of-pipe stormwater management facility (SWMF) will provide quantity control for storm runoff from the site.
- On-site stormwater quality control will be provided using oil-grit separator unit (OGS). It will provide a normal level of water quality treatment corresponding to 80% long-term total suspended solids removal.

The OGS unit will require regular inspection and maintenance as outlined in the Stormceptor Owners Manual.
- Temporary erosion and sediment control will be provided during construction.

## 9.0 CLOSURE

The preceding report is respectfully submitted for review and approval. Please contact the undersigned should you have questions or require additional information.

### NOVATECH

Prepared by:



**Ryan Good, C.E.T**  
Design Technologist, Land Development  
and Public Sector Infrastructure

Reviewed by:

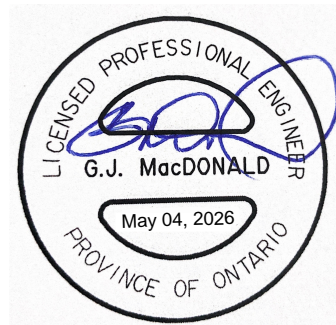

**Greg MacDonald, P.Eng**  
Director, Land Development and Public  
Sector Infrastructure

SWM Design by:

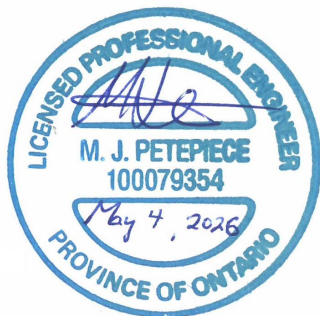

**Michael Petepiece, P.Eng**  
Senior Project Manager I  
Water Resources

## Appendix A

### Pre-Consultation Correspondance



July 11, 2024

Jeff Kelly  
NOVATECH Engineers, Planners & Landscape Architects  
Via email: j.kelly@novatech-eng.com

**Subject: Pre-Consultation: Meeting Feedback  
Proposed Site Plan Control Application – 541 Somme Street**

Please find below information regarding next steps as well as consolidated comments from the above-noted pre-consultation meeting held on July 5, 2024.

**Pre-Consultation Preliminary Assessment**

1 <input type="checkbox"/>	2 <input type="checkbox"/>	3 <input type="checkbox"/>	4 <input type="checkbox"/>	5 <input checked="" type="checkbox"/>
----------------------------	----------------------------	----------------------------	----------------------------	---------------------------------------

One (1) indicates that considerable major revisions are required while five (5) suggests that the proposal appears to meet the City’s key land use policies and guidelines. This assessment is purely advisory and does not consider technical aspects of the proposal or in any way guarantee application approval.

**Next Steps**

1. As a result of Bill 185, you are no longer required to go through a pre-consultation process. However, it is recommended that you apply for a pre-consultation prior to submitting the Site Plan Control application to ensure a complete submission.

**Supporting Information and Material Requirements**

1. The attached **Study and Plan Identification List** outlines the information and material that has been identified, during this phase of pre-consultation, as either required (R) or advised (A) as part of a future complete application submission.
  - a. The required plans and studies must meet the City’s Terms of Reference (ToR) and/or Guidelines, as available on [Ottawa.ca](http://Ottawa.ca). These ToR and Guidelines outline the specific requirements that must be met for each plan or study to be deemed adequate.

**Consultation with Technical Agencies**

1. You are encouraged to consult with technical agencies early in the development process and throughout the development of your project concept. A list of technical agencies and their contact information is enclosed.

## **Planning**

### Comments:

#### 1. Official Plan

- a. The subject property is designated Rural Industrial and Logistics as per *Schedule B9 – Rural Transect* of the Official Plan.
  - i. 9.3.1 (2) Development on lands designated as Rural Industrial and Logistics shall consider the following:
    1. Building design, Site layout and landscape in a way that maintains and enhances the rural identity and feel of the area in which such development takes place;
    2. Appropriate screening from public roads and adjacent properties using natural vegetation, preferably existing vegetation where possible;
    3. Outdoor amenity areas for employees and landscaping that supports the City's tree canopy targets; and
    4. Accesses are designed to minimize hazards between the road on which the development fronts and its vehicular points of access, such as freight transfer.
  - ii. 9.3.2 (1) The following uses are permitted in the Rural industrial and Logistics Area
    1. (b) Transportation, distribution, warehouse and large-scale storage operations
- b. Adjacent to Bedrock Resource Area Overlay
- c. Adjacent to mineral aggregate operations to the south and west of the parcel operated by Lafarge Canada and Tomlinson Group.
- d. Site of former Gloucester Concession 6 Dump
  - i. Years of operation and closure – 1920 -1991

#### 2. City of Ottawa Zoning By-law

- a. The subject property is zoned RH - Rural Heavy Industrial Zone.
  - i. A warehouse is a permitted use.

- ii. An office is permitted as accessory use.
- iii. Refuse collection areas must be screened from the street in accordance with Section 110(3) of the Zoning By-law.
- iv. Ensure all parking spaces, loading spaces, drive aisles conform with the requirements of Section [101](#), [107](#), [113](#) of the Zoning By-law.

### 3. Parking requirements

- a. N59 - Warehouse – Area D (Rural) – 0.8 parking spaces per 100m<sup>2</sup> of the first 5000 m<sup>2</sup> of gross floor area.
- b. N59 – Office – Area D (Rural) – 2.4 parking spaces per 100m<sup>2</sup> of gross floor area.

### 4. Discussion

- a. There is a 30 cm reserve that was placed during the establishment of the industrial subdivision agreement. It can be lifted as per requirements in clause 18 of Schedule F, Section D, of the subdivision agreement.
- b. Show the extent of the storage yards on the plans, including fencing, landscaping to buffer and screen parking and the storage yard. Snow storage needs to be identified as well as any exterior lights and ground-mounted signs (Sign Permit is separate from site plan).
- c. The severance needs to be perfected before the site plan can be registered. The 30 cm reserve would also need to be lifted.
- d. Fence off the rear area that is still treed.
- e. Provide bollards around septic system, well, and other sensitive facilities (eg fuel tanks).

### 5. Submission requirements

All Plans and Studies must meet the requirements of the [City's Terms of Reference](#).

- a. Plan of Survey
- b. Site plan
- c. Landscape plan
- d. Zoning confirmation report

- e. Preliminary construction management plan

Feel free to contact Jasdeep Brar ([jasdeep.brar@ottawa.ca](mailto:jasdeep.brar@ottawa.ca)), Planner I, for follow up questions.

### **Urban Design**

Comments:

- 6. Additional drawings and studies are required as shown on the SPIL. Please follow the terms of references ( [Planning application submission information and materials | City of Ottawa](#)) the prepare these drawings and studies. These include:
  - a. Site Plan
  - b. Concept Plan
  - c. Landscape Plan
  - d. Elevations
  - e. *Floor Plan (conceptual)*
- 7. **Comments on Preliminary Design** Applicants are to provide a response to these comments with the submission.
  - a. Please provide a concept plan illustrating ultimate build out of the property. Please ensure that storage is screened from the public road and that there is adequate space for truck turning to the rear of the building.
  - b. For building elevations facing the street, include architectural elements that provide some interest or engagement. The goal is to prevent blank facades facing public streets. Please ensure that entrances face the street.
  - c. Consider rotating the building by 90 degrees to increase frontage towards the public street.
  - d. Please provide tree planting can be provided in the Somme Street ROW.
  - e. Please provide additional screening landscaping and decorative elements (such as low fencing) along the site frontage as well as between the parking and the building.

Feel free to contact Lisa Stern ([lisa.stern@ottawa.ca](mailto:lisa.stern@ottawa.ca)), Urban Designer, for follow up questions.

## Engineering

### Comments:

#### 8. Site specific information:

- a. The proposal is within former unknown landfill and therefore Impact Assessment Study (Waste Disposal Sites/Formal landfills) will be required to ensure that issues of public health and safety are addressed.
- b. In accordance with the Schedule "F" (Special Conditions) of the Subdivision Agreement, the proposal is subject to the Area Specific Development Charge for the Osgoode Greely Erosion Control, By-law No. 2004-315, or as amended, at the time of the building permit application.
- c. It is understood that the identified property, on the concept plan, is subject to Severance Conditions and that the shown severance has not been approved yet.

Severance process needs to be completed, before the Application can proceed.

#### 9. Topographic plan of survey

- a. The Survey needs to identify all representative elevation points, currently existing features, including all property lines, bodies of water, vegetation, easements etc. It needs to provide a note that references the horizontal and vertical datums that were used and tied into to complete the project, including the local benchmarks. The survey should show the municipal road ROW and dimension the distance between the road centre line and the site property line.

#### 10. Servicing Study and Report (water/sanitary/SWM)

(There are no municipal services adjacent the proposal)

- a. Servicing Study and Plans will need to be submitted for review and they need to demonstrate that the site can be adequately serviced by private servicing. The report should provide the available water quantity and quality information. It should also identify the required projected water demand for the proposal and the expected well capacity (sustainably to be in excess of the demand) and make direct references to the source of the information used in the reporting (i.e.: Hydrogeological and Terrain Analysis or other, if applicable).
- b. The septic bed sizing needs to be provided, to demonstrate that it will be able to accommodate the generated flows and there is an adequate lot area to provide required nitrate dilution. Rationale will need to be provided,

which will allow to conclude that the existing hydrogeological and geotechnical conditions were considered.

- c. Please also note that thin soils are anticipated on site, with the overburden thickness less than 2 meters.
- d. Please also note that this site is near Findlay Creek Municipal Drain and within the boundaries of the Shield's Creek and North Castor River, therefore applicable Subwatershed Studies and contamination prevention measures need to be considered.
- e. Fire-fighting considerations should also be included in the report to determine fire-fighting flows (volume of water) and potential property area allocation requirements, if water storage tanks need to be implemented (supported by calculations).
- f. The report needs to provide all pertinent calculations and justifications to support any claims made in the report. Any reliance on relevant studies should be clearly stated. The report should be completed exceeding the minimum requirements laid out in the Site Servicing Study Terms of Reference.

## 11. Fire Services

- a. It is the responsibility of the owner to ensure that an adequate water supply for firefighting is provided. Proposed structures with a footprint of less than 600 sq.m., and not containing a medium or high hazard occupancy can elect to proceed with the Ontario Building Code method for determining required fire flows. Otherwise, the FUS in conjunction with the NFPA 1142 methodologies will need to be considered and OFS support of the proposed findings will be required.
- b. Enhanced review will be invoked, should the construction coefficient be chosen less than 1. Total effective floor area needs to be carefully considered. The applicant can contact Allan Evans (Allan.Evans@ottawa.ca) with Ottawa Fire Services to discuss operational issues.
- c. It needs to be noted that, if required, the FUS firefighting water demands are significant, and this will require substantial water storage on site. The cost of such tanks will not be accepted as cause for deviation.
- d. Fire Routes now require designation with By-law through the Site Plan process by contacting fireroutes@ottawa.ca. and the City engineering needs to be cc'd on the communication.

## 12. Stormwater

- a. A Stormwater management (SWM) report and Pre- and Post-development drainage plans will be required, to confirm that the surface run-off can be controlled on site. All stormwater management determinations shall have supporting rationale and should adequately address the site conditions, while considering concurrence with the applicable guidelines, such as, but not necessarily limited to "*Sewer Design Guidelines, Second Edition, document no. SDG002, October 2012, City of Ottawa, including technical bulletins*," Stormwater Management Report – Hawthorne Industrial Park 2009", "*City of Ottawa – Shields Creek – June 2004*" Subwatershed study and North Castor River Subwatershed Study.
- b. The proposal will need to show Legal and sufficient storm outlet from site for both release rate and volume. Stormwater cannot be directed to the adjacent properties; it can only be directed to the road ROW. The ditches will need to be shown to provide continuous flow to an outlet.
- c. Capacity of the downstream systems needs to be investigated in detail.
- d. Since it is a commercial development proposal, within a Rural Heavy Industrial Zoning, on-site SWM measures need to be applied.
- e. The SWM quantity criteria should be such, as per existing Subdivision agreement, which states that each site needs to provide a SWM control in accordance with the " Stormwater Management Report – Hawthorne Industrial Park, prepared by J.L Richards & Associates, revised May 2009", which specified that the post-development flows must be controlled to the pre-development levels for storms ranging from 1:2 Year to a 1:100 year recurrence.
- f. Stormwater Management approach, runoff volume control should proceed in the following hierarchical order, with each step exhausted before proceeding to the next:
  - i. Retention (infiltration, reuse, or evapotranspiration),
  - ii. Low Impact Development (LID) filtration, and
  - iii. Conventional Stormwater management. Conventional stormwater management should proceed only once Maximum Extent Possible has been attained for Steps 1 and 2 for retention and filtration.
- g. The pre-development surface run-off coefficient for the site needs to be determined using the smaller of a run-off coefficient (maximum equivalent 'C' of 0.5 [0.4 in combined areas] or the actual existing run-off coefficient) as per § 8.3.7.3 of the City of Ottawa Sewer Design Guidelines, Second Edition, October 2012, with bulletins.

- h. While calculating post-construction composite C coefficient, 25% needs to be added to the C value, to incorporate statistical changes in different event frequencies. The run-off calculation coefficients need to be performed, as per OSDG (second edition, October 2012), section 5.4.5
- i. A calculated time of concentration (cannot be less than 10 minutes) is required and it needs to be justified.
- j. Any existing stormwater runoff from adjacent site(s) that crosses the property must be accommodated by the proposed stormwater management design. No adverse effect can be created to the surrounding properties.
- k. Please note that Findlay Creek Municipal Drain in near the proposal and potential surface run-off impacts from the site need to be investigated.
- l. The water quality control should be an enhanced level treatment with 80% (not 70%, as originally specified) long term suspended sediment removal, in part, due to environmental issues in the area; more information is provided below in sub-point (m) in the bullet addressing the Hawthorne Industrial Park below. Reporting of TSS removal shall be extensive and, if peer reviewed and published papers are relied on for conclusions, the conclusions shall be clear, and the report shall show overwhelming agreement.
- m. This site is part of the Hawthorne Industrial Park, that was accepted in 2009, and is subject to the conditions of the subdivision agreement. A stormwater management pond was constructed as part as the development of this park. The pond was designed to provide 70% TSS removal, however the current requirement for water quality treatment is an enhanced level of protection which corresponds to 80% TSS removal.
  - i. The subdivision agreement, in schedule F, section C, covenant 7 requires an oil/grit separator to be provided on each lot. "Each site will be required to install and maintain, at the Transferee's expense, an oil/grit separator to provide quality treatment of surface runoff before entering the roadside open ditch/culvert system."
  - ii. A stormwater management report – Hawthorne Industrial Park (2009), appears to show a design runoff coefficient of 0.7, though the consultant should satisfy themselves of such; the quantity control design may merely need to be the difference between the proposed and 0.7. It is suggested that the consultant procure a copy of the stormwater management report for Hawthorne Industrial Park for coordination. The stormwater management report was prepared by J.L. Richards & Associates Limited (J.L.R.

Project #: JLR 20983; City Index #: R-2973) Revision date May 2009.

- iii. Stormwater Management Report – Hawthorne Industrial Park (2009) also notes that to control erosion potential, per the Shield’s Creek Subwatershed Study, to current levels, the 2-yr post development peak flow rate should be controlled to 50% of the 2-yr pre-development peak flow rate. The consultant should perform this control in addition to the criteria noted above.
- n. Snow Storage area should be separated from the septic field locations so there is no snow melt impacting the septic field. In addition, the snow storage areas should drain into the SWM system for discharge from the site.
- o. Supported by hydrogeological and geotechnical conditions, Low Impact Development (LID) needs to be implemented.
  - i. Low Impact Development (LID) is a stormwater management strategy that seeks to mitigate the impacts of increased runoff and stormwater pollution using practices that help to preserve or to restore pre-development hydrological and ecological functions. LID is a requirement as per the bulletin from the former MOECC (now Ministry of Environment, Conservation and Parks/ “MECP”) titled Expectations RE: Stormwater Management released in February 2015. Prior to implementing infiltration style measures there are site characteristics that must be determined. Supporting data collection will involve groundwater monitoring (long term or limited date with a conservative assumption), soil classification, and measured infiltration/percolation testing which will aid the consultant in determining what measures are, or are not, suitable for the site. The infiltration target for sites can at times be determined from an applicable higher-level study, which will also require confirmation through on-site infiltration/percolation testing.
  - ii. The reporting should identify the treatment train of processes proposed for the development. The Official Plan defines LID as a stormwater management strategy that seeks to mitigate the impacts of increased runoff and stormwater pollution by managing runoff as close to its source as possible. LID comprises a set of site design strategies that minimize runoff through distributed, small scale structural practices that mimic natural or predevelopment hydrology through the processes of infiltration, evapotranspiration, harvesting, filtration and detention of stormwater. These practices can effectively remove nutrients, pathogens and metals from runoff, and they reduce the volume and intensity of stormwater flows.

- iii. The City has released a document titled 'Low Impact Development Technical Guidance Report – Implementation in Areas with Potential Hydrogeological Constraints' which aids the consultant on options for sites which may have constraints such as low permeability or high groundwater, which are common constraints for the Ottawa area.
  
- p. Please also note that thin soils are anticipated on site, with the overburden thickness less than 2 meters.
  
- q. Note that the site is within South Nation Conservation Authority Source Water Protection Area with highly vulnerable aquifer on site and Unevaluated Wetlands identified directly to the south of the proposal. The site is also surrounded to the north, south and east with a Significant Groundwater Recharge Area, therefore, given the industrial nature of the site, surface water and groundwater protection measures should be considered in the SWM process.
  
- r. OGS application will likely require ECA approval. Note that oil/grit separators also require Environmental Technology Verification (ETV) protocol for ECA approval.
  
- s. Erosion and sediment control measures need to be provided in the report.
  
- t. As the site is within the boundaries of the Shield's Creek and North Castor River Subwatershed Studies. The following sections are provided for context, but do not reflect all the requirements of the study, which should be read in full by the consultant preparing the design of the works:
  - i. Shield's Creek Subwatershed Study:
    1. Low-capacity Issues – Section 4.7 (p. 4-26, sheet 46), Table 4.7.1 identifies hydraulic capacities of structures with the study area.
    2. Water Quality – Section 6.3.2 and 6.3.4.6 (p. 6-15, sheet 116), \* "Provide stormwater management to Provincial Policy – Level 2 (MOEE Guidelines, 1999) or Normal Level of Protection (MOE, 2003). This will provide for the control of TSS and generally provides similar control for metals and nutrients."
    3. SWM pond canopy – Section 5.6.4/5.6.5 and table 6.2.3 referencing section 95 of Figure 4.10.1, and providing 70% canopy effect surrounding SWM ponds could reduce temperature impacts on downstream receivers.

4. Stormwater Management Measures – Section 6.3.4.4 “At-source controls are generally the most effective means of providing water quality protection. This includes measures such as lot layout, using grassed areas for stormwater, at-source infiltration. These types are typically the most effective controls since they prevent pollutants from entering the drainage system and provide for flow retention at-source, which best replicates headwater systems in a pre-development condition. In addition, at-source and conveyance controls that include infiltration, go towards meeting other objectives such as baseflow protection and temperature reduction.”
5. Infiltration rates - Section 6.3.4.7 (p.6-16, sheet 117)
  - a. Table 6.3.2 – Infiltration Targets which provides anticipated infiltration rate depending on the soil types noted.
  - b. Figure 5.5.1 – Infiltration Rates provides a map of anticipated infiltration rates.
  - c. Figure 5.5.1 seems the site has a range of 50 - 250 mm/hr (paleozoic bedrock) anticipated infiltration rate, based on the shading type in the Hawthorne Industrial Park.
- ii. North Castor River Subwatershed Study.
  1. Action 6, provides that sites must make efforts to ensure that stormwater or other sources of water contamination be safely discharged to minimize their impact on the water quality of the North Castor River. The report notes that if care is not taken in land-use planning and development, water quality deterioration will be unavoidable, and the ecosystem biota components of the North Castor River could suffer severe degradation.
- iii. IMPORTANT:

\* Where the Shields Creek Subwatershed Study, North Castor River Subwatershed Study, and the City’s provided quantity and quality criteria do not agree, the more stringent criteria shall be applied.

### 13. Grading and Drainage.

- a. Grading and Drainage Plans (pre-development and post-development) will be required to identify the existing and proposed drainage patterns and their relationship with the surface runoff control.  
The Grading and Drainage Plan should propose site, grading, building, and servicing design measures to protect new development from flooding as per policy 6, section 4.7.1 of the Official Plan. The Grading and Drainage Plan forms part of the requirements for Site Plan Control applications noted in the Studies and Plan Identification List, provided with the feedback documents and should be prepared according to the City's Terms of Reference.
- b. There is an existing Grading Plan (Site Servicing and Grading) provided for the subdivision, which should be considered in the development of the proposed lot grading.
- c. The Plan should have a note that references the horizontal and vertical datums that were used and tied into to complete the project. The drawing should also make reference (on the face of the plan) to a satisfactory site benchmark that can be used by anyone with a level to carry out checks on the particular project.

#### 14. Erosion and Sediment Control.

- a. An Erosion and Sediment Control Plan will be required with the Site Plan Control Application, typically included as an addendum to the Site Servicing Study. The plan serves to identify erosion risks and determine controls to be put in place in order to reduce the amount of erosion and sediment deposition that occurs as part of a project. Erosion and sediment control plans shall have regard to Canadian Standards Association (CSA) W202 Erosion and Sediment Control Inspection and Monitoring Standard (as amended).

#### 15. Geotechnical Investigation.

- a. A Geotechnical Study Report will be required. The report should provide sufficient soils and engineering information to confirm that the site is suitable or can be made suitable for development based on the requirements of the Geotechnical Investigation and Reporting Guidelines for Development Applications in the City of Ottawa.
- b. Please note that available mapping indicates a potential for shallow overburden or thin soils over paleozoic bedrock (Sandstone & dolostone). Fill is possible on site, as the property is within former unnamed landfill.
- c. If sensitive marine clays are found on site, then an enhanced geotechnical investigation and exhaustive analysis will be necessary. Investigation of clays should be undertaken with; vane shear testing, Atterberg limits

testing (from a number of depths in each column), shrinkage, grain size, grade raise restriction, consolidation, compaction sensitivity, remolded strength and liquefaction analysis - amongst others.

- d. Earthquake analysis and potential for seismic liquefaction, rapid lowering of shear strength or liquefaction-like behaviour, of any soil type, analysis is also required to be undertaken and details, with clear conclusions, provided in the report.
- e. In sensitive marine clays, trees in proximity to foundations can cause foundation damage. The requirements of the City's Tree Planting in Sensitive Marine Clay Soils – 2017 Guidelines should be contemplated.
- f. If infiltration measures are proposed onsite (LID), the study should also include infiltration/percolation testing for SWM design within the area proposed for the infiltration features (this investigation might need to be coordinated with the Hydrogeological and Terrain analysis).
- g. The groundwater level is to be investigated and the level needs to be derived from spring-time investigation (or longer). Based on policy, estimates of groundwater level will be dismissed and instead actual recordings are required. Potential ground water table fluctuations need to be identified and their effect on the soil's behaviour needs to be studied and reported. Clear conclusions need to be provided.

The foundation drainage needs to be addressed. All conclusions and determinations shall have supporting rationale.

- h. The Geotechnical Study will need to include rationalization for the gravel or pavement structure design, including vehicle numbers and loading specific to the proposed uses. The study should contemplate/investigate at a minimum the pavement structure for light-duty and heavy-duty areas and the foundation design. Any improvements required to the potentially existing granular structure on site should be noted in the report and demonstrated clearly on the Grading & Drainage Plan.
- i. It appears from the City mapping that the site might have raised slopes near the property lines, towards the back of the property, therefore the Geotechnical study will need to address the overall slope stability on site. The Geotechnical Consultant needs to determine if a separate dedicated Slope Stability Study will be required or provide an adequate justification if it is not required. Please note that there is known importation of fill material, of unknown quality and of historically questionable origin, on site.

## 16. Hydrogeological and Terrain Analysis.

- a. There are no municipal watermains near the proposed development. A Hydrogeological and Terrain Analysis Report will be required to establish

that there is an adequate quantity and quality of groundwater to support the proposed development (in excess of the design demand) and it needs to provide assurance of its sustainability. The requirements for the Hydrogeological and Terrain Analysis Report are outlined in the [City of Ottawa Hydrogeological and Terrain Analysis Guidelines](#), Section 5.0: Site Plans.

- b. All proposed wells must be tested to confirm water quantity and quality suitability, prior to the site plan approval. Support must be provided for the pump test rate, which should be the maximum day rate (not average weekly use) for the development (conducted for 8 hours or more). The rate should consider the cumulative use (total demand on the entire site). If multiple wells will be in use, then each well must be tested individually. Pump test rate must be justified.
- c. The site is located at a bedrock aquifer fault/intersection between multiple bedrock aquifers and therefore the anticipated quantity/quality of groundwater is unknown or could be variable.
- d. A **30cm reserve** was placed on the lot based on recommendations made in the Subdivision Hydrogeological Report (December 2008) and Letter to the SNCA prepared by Golder Associates (April 2009).
  - i. Extended Well Casing: “All wells drilled on the property should be equipped with a minimum of two lengths (approximately 12 metres) of steel well casing or with casing extending a minimum of one metre into competent bedrock, whichever is greater.” (Page 6, Golder response letter to SNCA, 2009)
  - ii. Site Specific Investigation:
    1. “A site specific investigation should be conducted on each building lot prior to construction. The investigation should note the type of materials present in the area proposed for the sewage disposal bed, the depth to impervious material or water table and an estimate of the hydraulic conductivity of the material. Depending on the specific characteristics of the lot, shallow buried trenches or area beds may be appropriate. On others, a fully raised bed constructed on imported material may be required. It is recommended that sewage disposal systems be located in areas with a minimum of 0.3 metres of soil” (Page 6, Golder response letter to SNCA, 2009)
    2. “Due to the heterogeneity of the fill material, it was not felt that testing of the material would provide useful information that could be extrapolated to the entire site. For that reason,

Golder recommended that a site specific investigation be conducted prior to construction of a septic system on each lot.” (Page 3, Golder response letter to SNCA, 2009)

- e. Site will likely require an ECA for the SWM.
- f. The parameters of water quality that will be tested will be the “subdivision suite” known to local well testing companies, as well as trace metals, VOCs, and PAHs. Requirements are outlined in the City of Ottawa Hydrogeological and Terrain Analysis Guidelines. The report should also provide an assessment of adjacent land uses and, if available, the ESA for concerns and determine if any other parameters need to be tested (i.e. petroleum hydrocarbons, etc.). The subdivision agreement, in schedule F, section C, covenant 10, identifies that testing of Polycyclic Aromatic Hydrocarbons (PAHs) be provided as an additional parameter(s), at a minimum.

The water quality sampling and testing needs to be performed on all wells proposed on site.

If concerns are identified on site and/or on the adjacent properties, testing for additional contaminants might be required.

- g. If water quality above the MCCRT (Maximum Concentration Considered Treatable) is detected in the supply well/s, then the consultant should contact the reviewer to discuss potential options through a technical consultation, prior to any further field work.
- h. If well water is mineralized, then approval from the MECP will be needed to not abandon the well, as required in Ontario Regulation 903 (Section 21). The consultant should also consider the other issues associated with the mineralized water including corrosivity of the water and shortened lifespan of plumbing fixtures and the septic system. Specialized plumbing and fixtures may be beneficial to reduce the long-term issues.
- i. Any water table measurements needed to support the design must be derived from spring-time investigation to assess seasonally high levels.
- j. The report needs to discuss the proposed activities and provide multiple lines of evidence to demonstrate how the aquifer, the existing well users, and the surface water run-off will be protected from any potentially contaminating activities in the long-term, given that the site is surrounded to the north, south and east with a Significant Groundwater Recharge Area. This may include a discussion on how the site activities will be managed through the future ECAs.
- k. The report needs to investigate if the site is hydrogeologically sensitive. If the site is hydrogeologically sensitive, then mitigative measures are to be

recommended, to protect the underlying supply aquifer in the long term. This can include increased casing depth for any new drilled wells, increased separation distance between wells and SWM and septic systems, strategic placement and protection of wells and septic system, based on direction of groundwater flow and existing soil thickness, and additional protective construction measures for the septic systems such as a clay seal or advanced septic treatment (advance treatments are only applicable in SPA, not in the ZBLA considerations).

- l. Note that thin soils are anticipated on site, with the overburden thickness less than 2 meters, hence enhanced discussion and mitigation of the thin soils will be required in the Terrain Analysis.
- m. If a SWM pond, infiltration trench or similar stormwater management infrastructure is proposed, then supporting information needs to be harmonized and included in the Hydrogeological and Terrain Analysis Report and infiltration, percolation testing needs to be undertaken at the location of the proposed infiltration facility.
- n. A Septic System Impact Risk Assessment must be completed as part of the Hydrogeological and Terrain Analysis Report, as per the City's Hydrogeological and Terrain Analysis Report Guidelines and MECP Guideline D-5-4. Please refer to the City of Ottawa HGTA Guidelines for the predictive assessment for commercial/industrial developments (not residential developments). A septic impact assessment is required to confirm that there is sufficient septic dilution to not contaminate the underlying aquifer, as a result of the proposed activities.
- o. Since this application is a site plan (not lot creation or zoning) septic treatment (i.e. tertiary treatment with nitrate dilution) may be considered as part of the septic impact assessment calculations. A system certified though NSF or BNQ should be recommended.
- p. The subdivision agreement, in schedule F, section C, covenant 15, identifies that the investigation for sewage systems should include the types of materials present, depth to impervious material or the water table and an estimate of the hydraulic conductivity of the material.
- q. If system isolation is contemplated, the technical pre-consultation with the reviewer is required to ensure the assessment meets the minimum requirements identified in City Guidelines, and to confirm the minimum onsite testing requirements.
- r. If the expected daily design flow is less than 10,000 L/d, the septic permit from the Ottawa Septic System Office must be issued prior to Site Plan Approval being granted.

- s. If the sum of the septic flows from all the septic systems onsite is 10,000 L/day or greater, then an ECA will be required from the MECP for the septic system. If design is 10,000 L/day or greater but mitigation measures are proposed (i.e. balancing tanks, etc.) to reduce the daily discharge, a copy of communication with the MECP needs to be provided to the City to confirm if the ECA is required.
- t. If the total water taking from onsite wells will be more than the provincial 50,000 L/day threshold, a PTTW from the MECP will be required.
- u. Note that compact gravel will be considered impermeable in the septic impact assessment unless accompanied by field testing to confirm infiltration rates.
- v. Bollards, or other means of preventing vehicle access, will need to be provided between areas with vehicle access and the existing or proposed well(s). The well location should be shown on all plans; the grading plan should indicate that grading around the well meets O.Reg. 903 requirements, i.e. minimum well casing height above ground surface and the land around the well must slope away from the well to prevent pooling.
- w. OSSO septic system permit and the applicable MECP permits will be required prior to SPA approval.
- x. Technical consultation with the hydrogeological report reviewer is encouraged prior to commencing the field work program. Please provide a detailed work plan to the assigned Infrastructure Project Manager for comment in advance of the hydrogeological technical consultation.
- y. All minimum requirements outlined in the subdivision agreement must be considered. This may include recommendations related the wells, septic systems, stormwater management and fire protection which should be considered should they exceed City and MECP requirements.

#### 17. Phase 1 ESA report.

- a. Phase 1 Environmental Site Assessment (ESA) will be required, completed in accordance with Ontario Regulation (O.Reg.) 153/04.
  - i. The City's Historic Land Use Inventory identifies that the subdivision lies on the site of a former landfill, known as Gloucester Concession 6 dump.
  - ii. There is known Importation of Fill Material of Unknown Quality. Soil may be imported fill of questionable origin historically.

- iii. There is a private fuel outlet at 3500 Rideau which could be a potential contaminant dependent on groundwater flow direction.
- b. A Phase 2 ESA may be required, depending on the outcome of the Phase 1 ESA.

#### 18. Site Lighting.

- a. Exterior site lighting will require certification by a licensed professional engineer confirming the design complies with the following:
  - i. The location of the fixtures, fixture type (make, model, part number and the mounting height) is shown on one of the approved plans.
  - ii. Lighting must be designed only using fixtures that meet the criteria for Full Cut-off classification, as recognized by the Illuminating Engineering Society of North America (IESNA or IES), and
  - iii. It must result in minimal light spillage onto adjacent properties and road ROW. As a guideline, 0.5 foot-candle is normally the maximum allowable spillage.
  - iv. Lighting Certificate will need to be submitted to the City.

#### 19. Additional observations.

- a. Concept plan shows the property lines that are subject to severance process, which has not been yet completed.
- b. The Concept plan does not show the design of the entire property. Access driveways are shown discontinued.
- c. Peripheral edges of the property might have very steep slopes – subject to potential slope stability issues.
- d. Proposed water well/s and the septic bed/s locations are not shown on the plans.
- e. Snow storage areas need to be shown.
- f. Curbs, if proposed, should not extend to the road ROW with granular shoulders.
- g. Driveways appear to be too close to the property lines.

- h. Driveway corner radii are not shown at the interface with the road edge of pavement. They need to end at the road pavement, a minimum of 3m from the extension of the property lines to the edge of pavement and the corner radii intercept point.
- i. Fire routes around the building are not shown.

#### 20. Environmental Compliance Approval (ECA)

- a. Based on the information provided during the pre-consultation submission package, it is anticipated that an ECA would be required given the industrial use located on industrial land.
- b. Please note: Once the development application has been submitted, a request can be made to the City to consider a Transfer of Review (ToR) ECA for SWM works (ponds, ditches, culverts, etc.) for private property, instead of the direct submission ECA. This is subject to approval by the City and MECP. Note that the ECA requirements are currently in transition towards the linear ECA process and more details may become available depending on application submission timeline. It is recommended to check with the City when the development application is submitted to confirm the ECA process at that time. Direct submission remains an option for other application types that do not meet the CLI ECA process and are not reviewed through Transfer of Review
- c. More information can be determined by contacting the Ministry of the Environment, Conservation and Parks, Ottawa District Office to arrange a pre-submission consultation. Patrick Lalonde at [patrick.lalonde@ontario.ca](mailto:patrick.lalonde@ontario.ca) (Site Plan Control).
- d. Note that oil/grit separators require Environmental Technology Verification (ETV) protocol for ECA approval.

#### 21. Easements/ROW.

- a. Easements and rights-of-ways must be shown on the plans. Information on any existing easements details (who involved parties are, registration number, versions of the document including the latest, related by-laws etc.) with all supporting documentation need to be provided with the application.

#### 22. Energy conservation.

- a. Energy conservation is required to be demonstrated throughout design as per section 2.2.3 of the Official Plan (reduction of urban heat, renewable energy, mitigation of climate change impacts) and others.

#### 23. Construction Constraints.

- a. Any proposed fuel storage tanks will require protection and mitigation measures as they create a potential hazard on the site. A Spill Response and Contingency Plan, in addition to any provincial or federal requirements, will be required to ensure that risks are determined, and mitigation measures put in place.
- b. The design should contemplate locations of heavy traffic flow and movement on the site as it relates to the site layout and pavement design requirements.

#### 24. Roads.

- a. Please refer to the City of Ottawa Private Approach By-Law 2003-447 for the entrance design and reach out to the City Transportation department for the acceptable entrance locations and distance.
- b. It appears that the placement of the access driveways is too close to the property lines and the driveway corner radii are missing at the driveway/road edge of pavement interface.
- c. Please refer for more details to the City Transportation comments.

#### 25. Permits and Approvals.

- a. Please contact the South Nation Conservation Authority (SNCA), MECP, OSSO, etc., amongst other federal and provincial departments/agencies, to identify all the necessary permits and approvals required to facilitate the development. Responsibility rests with the developer and their consultant for determining which approvals are needed and for obtaining all external agency approvals. The address shall be in good standing with all approval agencies, for example SNCA, MECP, OSSO, etc., prior to site plan application approval. Copies of confirmation of correspondence will be required by the City of Ottawa from all approval agencies that a form of assent is given.
- b. An MECP ECA application is not submitted until after City of Ottawa Engineering is satisfied that components directly or indirectly aligned with the ECA process concur with standards, directives, and guidelines of the MECP.
- c. No construction shall commence until after a commence work notification is given by Development Review.

#### 26. Clarification on Using Historical Reports.

- a. It is unlikely that historical reports could be used to support the current application. Some studies, such as those prepared during the plan of subdivision application, may inform the studies prepared as part of this

application, but the focus should be on what information the study provides to the current proposal. Note that many studies remain valid for a period of time or may have been superseded by new regulations, guidelines, etc.

## 27. Background studies and/or subwatershed studies.

- a. Shield's Creek Subwatershed Study, as detailed in the Site Servicing Study section above, contains but is not limited to the following sections:
  - i. Stormwater Design Criteria – Section 4.6.1 (p.4-18, sheet 38),
  - ii. Low-capacity Issues – Section 4.7 (p. 4-26, sheet 46),
  - iii. Water Quality – Section 6.3.4.6 (p. 6-15, sheet 116),
  - iv. SWM pond canopy – Section 5.6.4/5.6.5 and table 6.2.3 referencing section 95 of Figure 4.10.1, and
  - v. Infiltration rate - Table 6.3.2 (depending on overburden), Section 6.3.4.7 (p.6-16, sheet 117), shown as Figure 5.5.1 (sheet 213), and required as per Table 7.5.1
- b. North Castor River Subwatershed Study.
  - i. Action 6, provides that sites must make efforts to ensure that stormwater or other sources of water contamination be safely discharged to minimize their impact on the water quality of the North Castor River. The report notes that if care is not taken in land-use planning and development, water quality deterioration will be unavoidable, and the ecosystem biota components of the North Castor River could suffer severe degradation.
- c. Where the Shields Creek Subwatershed Study, North Castor River Subwatershed Study, and the City's Sewer Design Guidelines have different criteria, the more stringent criteria should be applied.

## 28. Plan submission requirements.

- a. Topographic plan of survey.
- b. Site Servicing Plan.
- c. Site Grading Plan.
- d. Site Drainage Area Plans (pre- and post-development).
- e. Site Erosion and Sediment Control Plan.

- f. Lighting Plan Certificate (not required at submission, but for registration).

All identified required plans are to be submitted on standard A1 or Arch D size sheets as per City of Ottawa Servicing and Grading Plan Requirements.

29. Report submission requirements.

- a. Site Servicing Study/Report (Water & Sanitary; including firefighting considerations).
- b. Storm Water Management Report (including Erosion and Sediment Control Measures).
- c. Hydrogeological and Terrain Analysis Report.
- d. Geotechnical Report - Earthquake analysis and Seismic liquefaction and liquefaction-like potential (including rapid lowering of any soil's shear strength) is required to be provided in the report.
- e. Slope Stability Study (may be required)
- f. Phase 1 ESA report (Phase 2, if required).
- g. Impact Assessment Study (Waste Disposal Sites/Former landfills).

Feel free to contact Derek Kulyk (derek.kulyk@ottawa.ca), Project Manager, for follow-up questions.

**Noise**

Comments:

- 30. Not required.

Feel free to contact Mike Giampa (mike.giampa@ottawa.ca), TPM, for follow-up questions.

**Transportation**

Comments:

- 31. Because the proposed access must be in a curve, please ensure that sightline obstructions are minimized.

- 32. Right-of-way protection (Rural local).

- a. See [Schedule C16 of the Official Plan](#).

- b. Any requests for exceptions to ROW protection requirements must be discussed with Transportation Planning and concurrence provided by Transportation Planning management.

33. A TIA is not required.

Feel free to contact Mike Giampa (mike.giampa@ottawa.ca), Transportation Project Manager, for follow-up questions.

### **Environment**

Comments:

- 34. A Tree Conservation Report (TCR) is not required for this application, so long as the applicant confirms that there is no intention of removing the trees along the back of the site. If that is the case, then the site plan should be updated to show the trees on site and demonstrate that they are to remain untouched by development.

Feel free to contact Mark Elliot (mark.elliott@ottawa.ca), Environmental Planner, for follow-up questions.

### **Forestry**

Comments:

- 35. Tree Conservation Report requirements - The following Tree Conservation Report (TCR) requirements have been adapted from the Schedule E of the Urban Tree Protection Guidelines – for more information on these requirements please contact hayley.murray@ottawa.ca
  - a. A Tree Conservation Report (TCR) must be supplied for review along with the suite of other plans/reports required by the City
  - b. City-owned trees of any diameter requires a tree permit issued under the Tree Protection Bylaw (Bylaw 2020 – 340); the permit will be based on an approved TCR and made available at or near plan approval.
  - c. The TCR must contain 2 separate plans:
    - i. Plan/Map 1 - show existing conditions with tree cover information.
    - ii. Plan/Map 2 - show proposed development with tree cover information.
  - d. The TCR must list all trees on site, as well as off-site trees if the CRZ (critical root zone) extends into the developed area, by species, diameter,

and health condition. Please note that averages can be used if there are forested areas.

- e. Please identify trees by ownership – private onsite, private on adjoining site, city owned, co-owned (trees on a property line)
- f. If trees are to be removed, the TCR must clearly show where they are, and document the reason they cannot be retained.
- g. The removal of trees on a property line will require the permission of both property owners.
- h. All retained trees must be shown, and all retained trees within the area impacted by the development process must be protected as per City guidelines available at Tree Protection Specification or by searching Ottawa.ca
- i. The city encourages the retention of healthy trees; if possible, please seek opportunities for retention of trees that will contribute to the design/function of the site.
- j. Removal of a City tree is not permitted unless justified. If justified, monetary compensation for the value of the tree must be paid before a tree removal permit is issued.

36. Landscape Plan Terms of Reference Requirements for Planting on Private and City Property:

- a. Landscape Plan Terms of Reference must be adhered to: ([https://documents.ottawa.ca/sites/documents/files/landscape\\_tor\\_en.pdf](https://documents.ottawa.ca/sites/documents/files/landscape_tor_en.pdf)).

37. Additional Elements for Tree Planting in the Right of Way:

- a. Please ensure any retained trees are shown on the LP
- b. Sensitive Marine Clay - Please follow the City's 2017 Tree Planting in Sensitive Marine Clay guidelines.
- c. The city requests that consideration be given to planting native species wherever there is a high probability of survival to maturity.
- d. Efforts shall be made to provide as much future canopy cover as possible at a site level, through tree planting and tree retention. The Landscape Plan shall show/document that the proposed tree planting and retention will contribute to the City's overall canopy cover over time. Please provide a projection of the future canopy cover for the site to 40 years.
- e. Minimum Setbacks

- i. Maintain 1.5m from sidewalk or MUP/cycle track or water service laterals.
  - ii. Maintain 2.5m from curb
  - iii. Coniferous species require a minimum 4.5m setback from curb, sidewalk, or MUP/cycle track/pathway.
  - iv. Maintain 7.5m between large growing trees, and 4m between small growing trees. Park or open space planting should consider 10m spacing, except where otherwise approved in naturalization / afforestation areas.
  - v. Adhere to Ottawa Hydro's planting guidelines (species and setbacks) when planting around overhead primary conductors.
- f. Tree specifications
- i. Minimum stock size: 50mm tree caliper for deciduous, 200cm height for coniferous.
  - i. Maximize the use of large deciduous species wherever possible to maximize future canopy coverage.
  - ii. Tree planting on city property shall be in accordance with the City of Ottawa's Tree Planting Specification; and if possible, include watering and warranty as described in the specification.
  - iii. No root barriers, dead-man anchor systems, or planters are permitted.
  - iv. No tree stakes unless necessary (and only 1 on the prevailing winds side of the tree)
- g. Hard surface planting
- i. If there are hard surface plantings, a planting detail must be provided.
  - ii. Curb style planter is highly recommended.
  - iii. No grates are to be used and if guards are required, City of Ottawa standard (which can be provided) shall be used.
  - iv. Trees are to be planted at grade.
  - v. Soil Volume - Please demonstrate as per the Landscape Plan Terms of Reference that the available soil volumes for new plantings will meet or exceed the minimum soil volumes requested.



Feel free to contact Hayley Murray (hayley.murray@ottawa.ca), Planning Forester, for follow-up questions.

### **Parkland**

Comments:

38. Payment of cash-in-lieu of conveyance of parkland has been previously satisfied for this site.

39. Should there be a change in use to residential then additional CIL would apply.

Feel free to contact Warren Bedford (warren.bedford@ottawa.ca), Parks Planner, for follow-up questions.

### **Conservation Authority**

Please contact James Holland (jholland@nation.on.ca), Planner, South Nations Conservation Authority, for comments.

Should there be any questions, please do not hesitate to contact myself or the contact identified for the above areas / disciplines.

Yours Truly,  
Jasdeep Brar and Cheryl McWilliams

Encl. Study and Plan Identification List  
List of Technical Agencies to Consult  
Supplementary Development Information Sheet

c.c. Leah Dykstra, Student Planner  
Derek Kulyk, Project Manager  
Damien Whittaker, Engineer  
Mark Elliot, Environmental Planner  
Lisa Stern, Urban Designer  
Hayley Murray, Forester  
Mike Giampa, Transportation Project Manager  
Warren Bedford, Parks Planner

## Appendix B

### Water Calculations

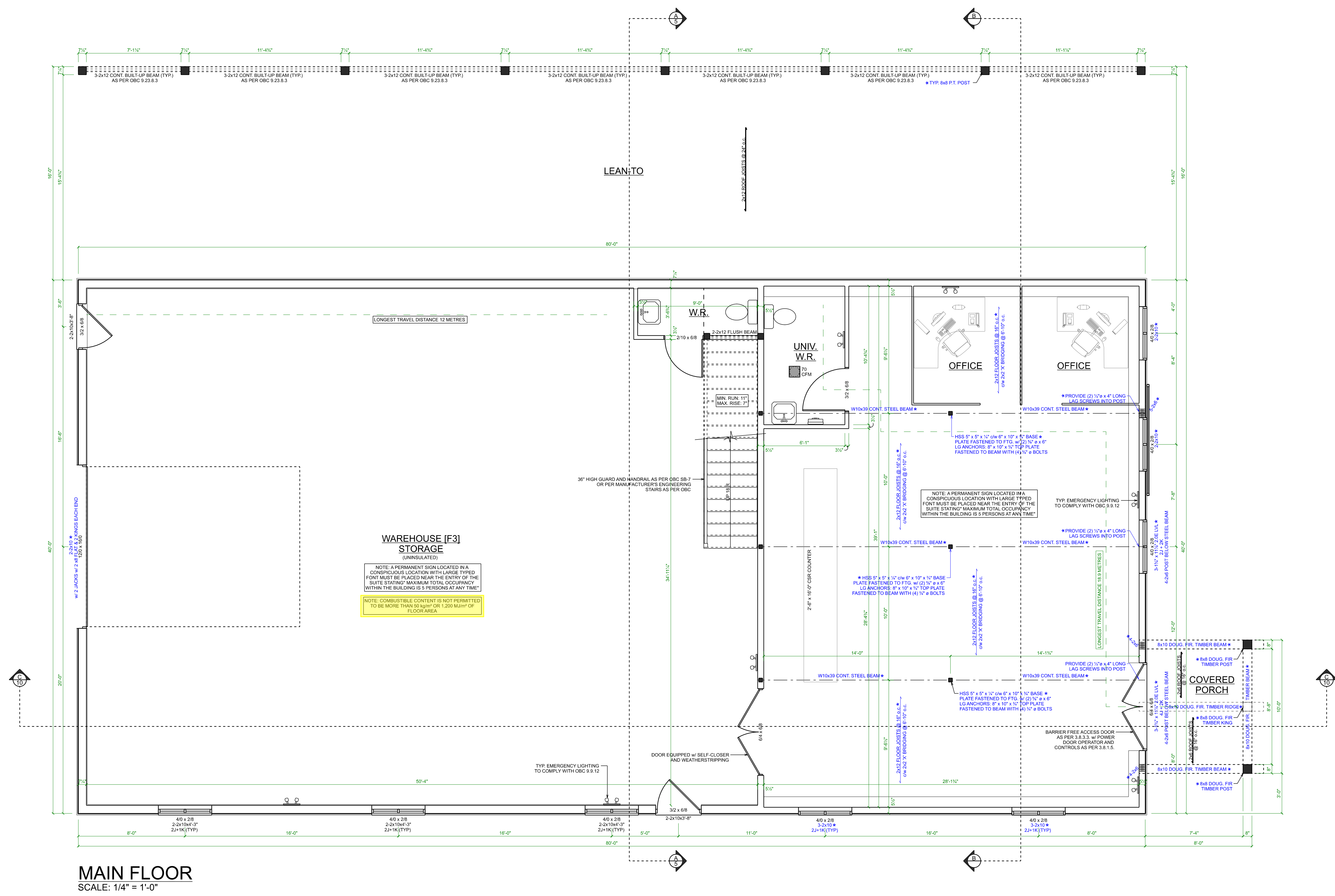

**MAIN FLOOR**  
SCALE: 1/4" = 1'-0"

**QUALIFICATION INFORMATION**

REQUIRED UNLESS DESIGN IS EXEMPT UNDER DIVISION C-3.2.4.1 OF THE 2012 O.B.C.

*J. Faber*

JAKOB FABER, BCIN 114291  
ELEVATE HOME DESIGN INC., BCIN 118456  
THE UNDERSIGNED HAS REVIEWED AND TAKES RESPONSIBILITY FOR THIS DESIGN AND HAS THE QUALIFICATIONS AND MEETS THE REQUIREMENTS SET OUT IN THE ONTARIO BUILDING CODE TO BE A DESIGNER.



BEATTY LINE N • FERGUS • ON  
WWW.ELEVATEHOMEDSIGN.CA  
JAKE@ELEVATEHOMEDSIGN.CA • 519-572-4561

**40 x 80 WAREHOUSE**  
TITAN ENVIRONMENTAL  
SOMME STREET, BLOCK 2, PART 1  
OTTAWA, ON

**MAIN FLOOR PLAN**

PROJECT NO: 24-001  
STARTING DATE: Jan 2, 2024  
LAST REVISION DATE: Apr 24, 2026  
DRAWN BY: J.F.

**2**

SCALE: 1/4" = 1'-0"

THESE DRAWINGS ARE COPYRIGHT PROTECTED AND MAY NOT BE COPIED OR REPRODUCED IN WHOLE OR IN PART WITHOUT EXPRESS WRITTEN CONSENT OF ELEVATE HOME DESIGN INC. ALL DIMENSIONS ARE TO BE VERIFIED BY ON-SITE CONTRACTOR AND ANY DISCREPANCIES TO BE REPORTED IMMEDIATELY TO THE ELEVATE HOME DESIGN INC. ALL CONSTRUCTION IS TO CONFORM TO THE ONTARIO BUILDING CODE AS AMENDED, REGARDLESS OF DRAWING DETAILS. FILE # D07-12-25-0077 PLAN # 19398

3.8.3.12. Universal Washrooms

(1) A universal washroom room shall... (a) be served by a barrier-free path of travel... (b) have a door that is capable of being locked from the inside and released from the outside in case of emergency and that has...

Appendix A

A-3.8.3.8.(3) Additional Grab Bars.

Designers may exceed the minimum requirements found in the Building Code and specify the installation of additional grab bars in other locations. These additional grab bars may be of different configurations and can be installed in other orientations.

A-3.8.3.8.(5) L-Shaped Grab Bar.

L-shaped grab bars provide greater support for people who rely on grab bars to assist them in transferring to and from a standing or seated position. Diagonally mounted grab bars may not be suitable for the downward force necessary for support or for pulling upward.

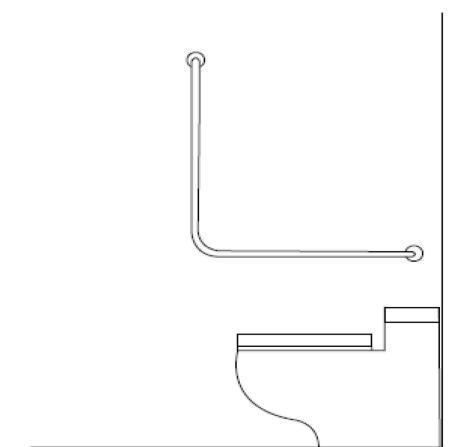

Permitted Continuous L-Shaped Grab Bar

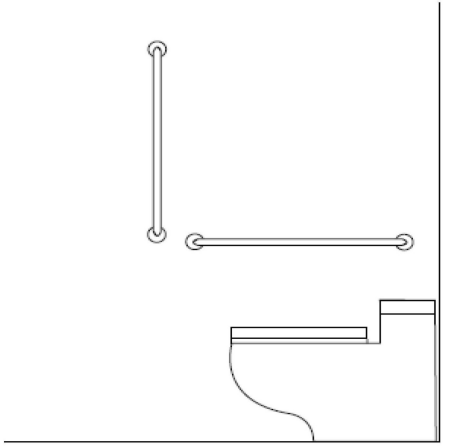

Not Permitted Discontinuous L-Shaped Grab Bar

3.8.3.11. Lavatories (See Appendix A.)

(1) A washroom described in Sentence 3.8.3.12.(1)(c) shall be provided with a lavatory that shall... (a) be located so that the distance between the centre line of the lavatory and the side wall is not less than 460 mm...

A-3.8.3.9. Water Closets.

Article 7.2.2.5. applies to water closets referenced in Articles 3.8.3.3., 3.8.3.9. and 3.8.3.12. A shelf or projection should not be located behind a water closet such that it could present a hazard.

A-3.8.3.9.(1)(c) Back Support at Water Closets.

The purpose of the back support is to reduce the chance of imbalance or injury caused by a user leaning against exposed flush valves or pipes. A toilet seat lid, where provided, may be a suitable back support.

A-3.8.3.9.(1) Water Closets.

Wall-mounted water closets or floor models with receding bases are preferable because they provide the least amount of obstruction.

A-3.8.3.11. Washroom Accessories.

Washroom accessories for barrier-free water closets and lavatories must be located within arm's reach of a person in a seated position. Placement of towel dispensers and hand dryers should not require that a person seated in a wheelchair must travel beyond the reach range of the lavatory to dry his or her hands.

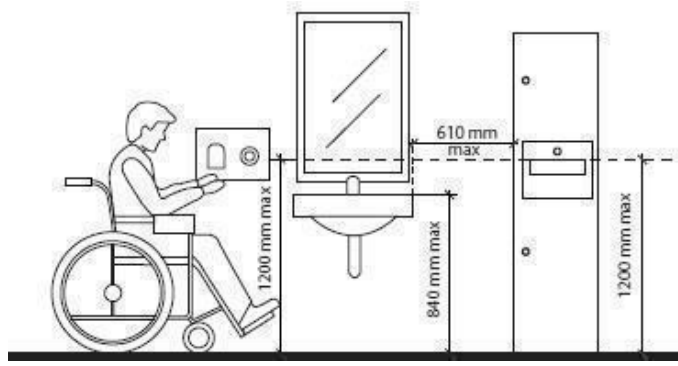

3.8.3.9. Water Closets (See Appendix A.)

(1) A water closet described in Clause 3.8.3.12.(1)(d) shall... (a) be equipped with a seat located at not less than 430 mm and not more than 465 mm above the finished floor...

3.8.3.3.(17) POWER DOOR OPERATORS

(17) The control for a power door operator shall... (a) have a face dimension of not less than 150 mm in diameter where the control is circular, or (i) 50mm by 100mm where the control is rectangular...

A-3.8.3.11.(1)(c) Clearances Beneath a Lavatory.

Barrier-free lavatories require sufficient knee and toe clearance below to permit a person in a wheelchair to move close enough to the faucet to easily use the water stream.

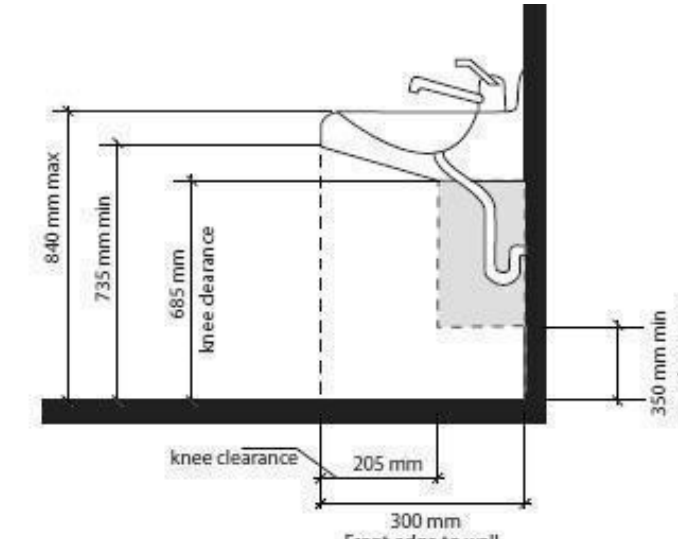

A-3.8.3.11.(1)(d) Pipe Protection.

The pipes referred to in Clause 3.8.3.11.(1)(d) include both supply and waste pipes. The hazard can be prevented by insulating the pipes, by locating the pipes in enclosures, or avoided by limiting the temperature of the hot water to a maximum of 43°C.

A-3.8.3.11.(1)(f) Clear Space at Lavatory.

The clear space required for the wheelchair user to pull into the fountain may overlap with an adjacent barrier-free path of travel but should not prevent other building users from passing when the barrier-free lavatory is in use.

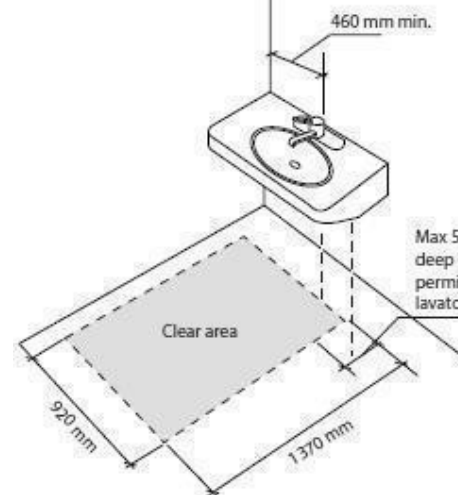

A-3.8.3.12.(1)(d) Transfer Space.

The transfer space beside a water closet or the approach space at a lavatory must be a clear space with no obstruction or potential obstruction of the space from adjacent elements such as a fold-down change table, or other fixture.

A-3.8.3.12.(1) and (3) Universal Washroom.

Unobstructed areas in front of the lavatory, in front of the water closet and on one side of the water closet are necessary for manoeuvrability of a wheelchair. The door swing may overlap the turning circle within the universal washroom as long as there is sufficient space for a wheelchair user to manoeuvre to clear the door and close the door from a front approach position.

A-3.8.3.12.(2) Emergency Call System.

The purpose of the emergency call system is to notify other building occupants that a person using the universal washroom requires assistance. The visual signal and alarm should be different from the building fire and smoke alarms and visual signals, where installed, as this call system is for personal, not building, emergencies.

12.2.4.1. Motion Sensors

(1) Lighting installed to provide the minimum illumination levels required by this Code may be controlled by motion sensors except where the lighting... (a) is installed in an exit, (b) is installed in a corridor serving patients or residents in a Group B, Division 2 or Division 3 occupancy, or (c) is required to conform to Sentence 3.2.7.1.(6).

ENGINEER'S STRUCTURAL NOTES:

GENERAL
1. THE STRUCTURE IS TO BE BUILT IN ACCORDANCE WITH THE REQUIREMENTS OF THE 2012 OBC, AND ANY APPLICABLE REQUIREMENTS OR BY LAWS OF THE AUTHORITY HAVING JURISDICTION.
2. THE CONTRACTOR SHALL ENSURE THE STABILITY AND THE INTEGRITY OF THE STRUCTURE AT ALL STAGES OF CONSTRUCTION.
3. THE CONTRACTOR IS RESPONSIBLE FOR LOCATING AND PROTECTING UTILITIES DURING ALL STAGES OF THE WORK.

CONCRETE
1. CONCRETE SHALL CONFORM TO THE REQUIREMENTS OF CSA A23.1.2.3 FOR MATERIALS AND WORKMANSHIP.
LOCATION CLASS STRENGTH
EXTERIOR WALLS F-2 25 MPa
FOOTINGS F-2 25 MPa
PIERS F-2 25 MPa
INTERIOR SLAB ON GRADE N 32 MPa

FOUNDATION
1. CONSTRUCT ALL FOOTINGS ON UNDISTURBED SOIL. EARTH BOTTOMS OF EXCAVATIONS TO BE DRY UNDISTURBED SOIL, LEVEL, FREE FROM LOOSE OR ORGANIC MATERIAL. REPLACE UNSUITABLE MATERIAL WITH GRANULAR MATERIAL COMPACTED TO 98% S.P.D.
2. AN ALLOWABLE BEARING PRESSURE CAPACITY OF 15 kPa SHALL BE CONFIRMED DURING CONSTRUCTION AT STRIP FOOTINGS, SPREAD FOOTINGS WITH AND WITHOUT PIERS, AND LEAN-TO PIERS.

STRUCTURAL STEEL
1. STRUCTURAL WIDE FLANGE SHAPES SHALL CONFORM TO CAN/CSA G40.20/G40.21 GRADE 350W OR ASTM A992/992M GRADE 50
2. ANGLE AND PLATES SHALL CONFORM TO CAN/CSA G40.20/G40.21 GRADE 350W.
3. HOLLOW STRUCTURAL SECTIONS TO CONFORM TO ASTM A500 GRADE C.

FOUNDATION
1. CONSTRUCT ALL FOOTINGS ON UNDISTURBED SOIL. EARTH BOTTOMS OF EXCAVATIONS TO BE DRY UNDISTURBED SOIL, LEVEL, FREE FROM LOOSE OR ORGANIC MATERIAL. REPLACE UNSUITABLE MATERIAL WITH GRANULAR MATERIAL COMPACTED TO 98% S.P.D.
2. AN ALLOWABLE BEARING PRESSURE CAPACITY OF 15 kPa SHALL BE CONFIRMED DURING CONSTRUCTION AT STRIP FOOTINGS, SPREAD FOOTINGS WITH AND WITHOUT PIERS, AND LEAN-TO PIERS.

FOUNDATION
1. CONSTRUCT ALL FOOTINGS ON UNDISTURBED SOIL. EARTH BOTTOMS OF EXCAVATIONS TO BE DRY UNDISTURBED SOIL, LEVEL, FREE FROM LOOSE OR ORGANIC MATERIAL. REPLACE UNSUITABLE MATERIAL WITH GRANULAR MATERIAL COMPACTED TO 98% S.P.D.
2. AN ALLOWABLE BEARING PRESSURE CAPACITY OF 15 kPa SHALL BE CONFIRMED DURING CONSTRUCTION AT STRIP FOOTINGS, SPREAD FOOTINGS WITH AND WITHOUT PIERS, AND LEAN-TO PIERS.

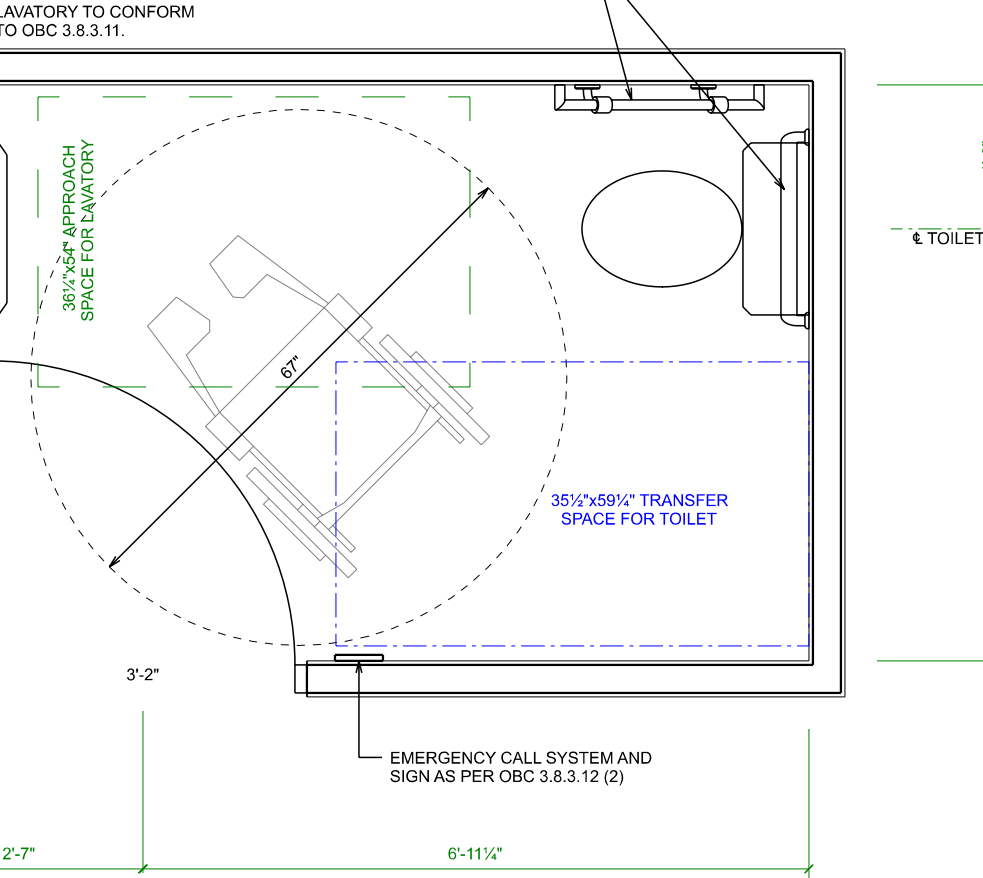

UNIVERSAL WASHROOM DETAIL SCALE: 1/2" = 1'-0"

TABLE SB 5.5-6-2017 (See Appendix A.) (Supersedes Table 5.5-6 in 2013 ANS/ASHRAE/IES 90.1) Building Envelope Requirements for Climate Zone 6 (A, B) (I-P)

Table with columns for Opaque Elements, Nonresidential, Residential, and Semihatched, and sub-columns for Assembly, Insulation, Max. U-Value, and Min. R-Value.

The following definitions apply: ci = continuous insulation, La = liner system, NR = no (insulation) requirement. \* When using the R-value compliance method for metal building roofs, a thermal spacer block is required.

ONTARIO BUILDING CODE MATRIX - PART 9

Table listing building code requirements for Warehouse (F3) with columns for Item, Description, and Code Reference.

ONTARIO FIRE CODE

Table listing fire code requirements for fire extinguishers with columns for Item, Description, and Code Reference.

QUALIFICATION INFORMATION section with signature of Jakob Faber and contact details for Elevate Home Design Inc.

ONTARIO OUTBUILDING logo and branding.

ELEVATE HOME DESIGN logo and contact information for Beatty Line N, Fergus, ON.

40 x 80 WAREHOUSE advertisement for Titan Environmental, Somme Street, Block 2, Part 1, Ottawa, ON.

OBC NOTES & UNIVERSAL W.R. section header.

Project information including Project No: 24-001, Start Date: Jan 2, 2024, and Scale: As Noted.

### 1.3.3.2. Application of Parts 3, 4, 5 and 6

- (1) Subject to Articles 1.3.3.1A., 1.3.3.3B., Parts 3, 4, 5, and 6 of Division B apply to all *buildings* described in Article 1.1.1.1. and
  - (a) classified as *post-disaster buildings*,
  - (b) used for *major occupancies* classified as
    - (i) Group A, *assembly occupancies*,
    - (ii) Group B, *care, care and treatment or detention occupancies*, or
    - (iii) Group F, Division 1, *high-hazard industrial occupancies*, or
  - (c) exceeding 600 m<sup>2</sup> in *building area* or exceeding 3 *storeys* in *building height* used for *major occupancies* classified as
    - (i) Group C, *residential occupancies*,
    - (ii) Group D, *business and personal services occupancies*,
    - (iii) Group E, *mercantile occupancies*, or
    - (iv) Group F, Divisions 2 and 3, *medium- and low-hazard industrial occupancies*.
- (2) Subject to Articles 1.3.3.1A. and 1.3.3.3B., Part 4 of Division B applies to
  - (a) a retaining wall exceeding 1 000 mm in exposed height adjacent to
    - (i) public property,
    - (ii) access to a *building*, or
    - (iii) private property to which the public is admitted,
  - (b) a pedestrian bridge appurtenant to a *building*,
  - (c) a crane runway,
  - (d) an exterior storage tank and its supporting structure that is not regulated by the *Technical Standards and Safety Act, 2000*,
  - (e) signs regulated by Section 3.15. of Division B that are not structurally supported by a *building*,
  - (f) a structure that supports a wind turbine generator having a rated output of more than 3 kW,
  - (g) an *outdoor pool* that has a water depth greater than 3.5 m at any point, and
  - (h) a *permanent solid nutrient storage facility* with supporting walls exceeding 1 000 mm in exposed height.
- (3) Section 3.11. of Division B applies to *public pools*.
- (4) Section 3.12. of Division B applies to *public spas*.
- (5) Section 3.15. of Division B applies to signs.
- (6) Section 3.17. of Division B applies to *demountable stages* and *demountable support structures*.

### 1.3.3.2A. Application of Part 8

- (1) Subject to Article 1.3.3.3B., Part 8 of Division B applies to the design, *construction*, operation and maintenance of all *sewage systems* and to the *construction of buildings* in the vicinity of *sewage systems*.

### 1.3.3.3. Application of Part 9

- (1) Subject to Article 1.3.3.3B., Part 9 of Division B applies to all *buildings* described in Article 1.1.1.1. of 3 *storeys* or less in *building height*, having a *building area* not exceeding 600 m<sup>2</sup>, and used for *major occupancies* classified as
  - (a) reserved,
  - (b) Group C, *residential occupancies* other than *buildings* used for *retirement homes*, (See Note A-9.1.1.1.(1) of Division B)
  - (c) Group D, *business and personal services occupancies*,
  - (d) Group E, *mercantile occupancies*, or
  - (e) Group F, Divisions 2 and 3, *medium- and low-hazard industrial occupancies*.

- (4) Illumination from lighting required in Sentence (1) shall be provided to average levels of not less than 10 lx at floor or tread level.
- (5) The minimum value of the illumination required by Sentence (4) shall be not less than 1 lx.
- (6) Where incandescent lighting is provided, lighting equal to 1 W/m<sup>2</sup> of *floor area* shall be considered to meet the requirement in Sentence (4).
- (7) Where self-contained emergency lighting units are used, they shall conform to CSA C22.2 No. 141, “Emergency lighting equipment.”

## Section 9.10. Fire Protection

### 9.10.1. Definitions and Application

#### 9.10.1.1. Sloped Roofs

- (1) For the purposes of this Section, roofs with slopes of 60° or more to the horizontal and that are adjacent to a room or space intended for *occupancy* shall be considered as a wall.

#### 9.10.1.2. Testing of Integrated Fire Protection and Life Safety Systems

- (1) Where life safety and fire protection systems and systems with fire protection and life safety functions are integrated with each other, they shall be tested as a whole in accordance with CAN/ULC-S1001, “Standard for Integrated Systems Testing of Fire Protection and Life Safety Systems,” to verify that they have been properly integrated. (See Note A-3.2.9.1.(1))
- (2) Sentence (1) does not apply to a *building* that contains only *dwelling units* and has no *dwelling unit* above another *dwelling unit*.

#### 9.10.1.3. Items Under Part 3 Jurisdiction

- (1) Tents, *air-supported structures*, transformer vaults, *walkways*, elevators and escalators shall conform to Part 3.
- (2) Where rooms or spaces are intended for an *assembly occupancy*, such rooms or spaces shall conform to Part 3.
- (3) *Basements* containing more than 1 *storey* or exceeding 600 m<sup>2</sup> in area shall conform to Part 3.
- (4) Where rooms or spaces are intended for the storage, manufacture or use of hazardous or explosive material, such rooms or spaces shall conform to Part 3.
- (5) Reserved.
- (6) Openings through floors that are not protected by shafts or  *closures* shall be protected in conformance with Subsection 3.2.8. (See also Sentence 9.9.4.7.(1))
- (7) Chutes and shafts shall conform to Subsection 3.6.3. except where they are entirely contained within a *dwelling unit*.
- (8) Sprinkler systems shall be designed, constructed and installed in conformance with Articles 3.2.5.12. to 3.2.5.15. and 3.2.5.17. (See Note A-9.10.1.3.(8) and (9))

- (9) Standpipe and hose systems shall be designed, constructed and installed in conformance with Articles 3.2.5.8. to 3.2.5.11. and 3.2.5.17. (See Note A-9.10.1.3.(8) and (9))
- (10) Fire pumps shall be installed in conformance with Articles 3.2.5.17. and 3.2.5.18.
- (11) Where fuel-fired appliances are installed on a roof, such *appliances* shall be installed in conformance with Article 3.6.1.5.

#### 9.10.1.4. Items Under Part 6 Jurisdiction

- (1) In kitchens containing commercial cooking equipment used in processes producing grease-laden vapours, the equipment shall be designed and installed in conformance with Article 6.3.1.6. (See Note A-9.10.1.4.(1))

### 9.10.2. Occupancy Classification

#### 9.10.2.1. Occupancy Classification

- (1) Every *building* or part of it shall be classified according to its *major occupancy* as belonging to one of the groups or divisions described in Table 9.10.2.1.

Table 9.10.2.1.  
Occupancy Classifications  
Forming Part of Sentence 9.10.2.1.(1)

Group	Division	Description of <i>Major Occupancies</i> <sup>(1)</sup>
C	—	<i>Residential occupancies</i>
D	—	<i>Business and personal services occupancies</i>
E	—	<i>Mercantile occupancies</i>
F	2	<i>Medium-hazard industrial occupancies</i>
F	3	<i>Low-hazard industrial occupancies</i> (Does not include <i>storage garages serving houses or individual dwelling units</i> )

#### Notes to Table 9.10.2.1.:

- (1) See Note A-3.1.2.1.(1).

#### 9.10.2.2. Reserved

#### 9.10.2.3. Major Occupancies Above Other Major Occupancies

- (1) Except as permitted in Article 9.10.2.4., in any *building* containing more than one *major occupancy* in which one *major occupancy* is located entirely above another, the requirements of Article 9.10.8.1. for each portion of the *building* containing a *major occupancy* shall be applied to that portion as if the entire *building* was of that *major occupancy*.

#### 9.10.2.4. Buildings Containing More Than One Major Occupancy

- (1) In a *building* containing more than one *major occupancy*, where the aggregate area of all *major occupancies* in a particular group or division does not exceed 10% of the *floor area* on the *storey* on which they are located, they need not be considered as *major occupancies* for the purposes of Articles 9.10.2.3. and 9.10.8.1. provided they are not classified as Group F, Division 2 *occupancies*.

the fire alarm panel, which would provide notification to the supervisory personnel and be inspected as per CAN/ULC-S524, “Standard for Installation of Fire Alarm Systems.” It is not intended that smoke detectors used in lieu of smoke alarms will activate the fire alarm panel to send a signal to the fire department.

#### **A-3.2.4.20.(17) Smoke Alarms with a Visual Signalling Component.**

Smoke alarms with a visual signaling component can alert people who are deaf, deafened or hard of hearing to the presence of smoke in the dwelling just as the alarm sound provides an alert to people with no or low vision or who are sighted. The visual signal provides an extra level of safety alerts to building residents.

#### **A-3.2.4.22.(1)(b) Voice Messages.**

The concept of intelligibility expressed in Clause 3.2.4.22.(1)(b) is intended to mean that a person with average hearing and cognitive abilities is able to understand the messages that are transmitted into the space occupied by the person. There is no absolute measure to predetermine the effect of loudspeakers and it may be necessary, once the building has been furnished and occupied, to increase to the number of loudspeakers to improve the quality of the messages.

The intelligibility of the message depends on the speech level, the background level, and the reverberation time of the space. ISO 7731, “Ergonomics - Danger Signals for Public and Work Areas - Auditory Danger Signals”, addresses audibility. The standard suggests that an A-weighted sound level at least 15 dBA above the ambient is required for audibility, but allows for more precise calculations using octave or ½ octave band frequencies to tailor the alarm signal for particular ambient noise conditions. Design of the alarm system is limited to ensuring that all areas receive an adequately loud alarm signal.

If a public address system is to be used to convey instructions during an emergency, then the requirements of the system are less straightforward. In general, however, a larger number of speakers operating at lower sound levels would be required.

Additional guidance on how to design and evaluate the intelligibility of a communication system can be found in the following documents

- IEC 60268-16, Sound System Equipment — Part 16: Objective Rating of Speech Intelligibility by Speech Transmission Index
- ISO 7240-19, Fire Detection and Alarm Systems — Part 19: Design, Installation, “Commissioning and Service of Sound Systems for Emergency Purposes”
- NEMA SB 50, “Emergency Communications Audio Intelligibility Applications Guide”
- Annex D of NFPA 72, “National Fire Alarm and Signaling Code”.

#### **A-3.2.5.4.(1) Fire Department Access for Detention Buildings.**

Buildings of Group B, Division 1 used for housing persons who are under restraint include security measures that would prevent normal access by local fire departments. These security measures include fencing around the building site, exterior walls without openings or openings which are either very small or fitted with bars, and doors that are equipped with security hardware that would prevent easy entry. These buildings would have firefighting equipment installed and the staff would be trained to handle any small incipient fires. It is expected that appropriate fire safety planning would be undertaken in conjunction with local fire departments in order that special emergencies could be handled in a cooperative manner.

#### **A-3.2.5.6.(1) Fire Department Access Route.**

The design and construction of fire department access routes involves the consideration of many variables, some of which are specified in the requirements in the Building Code. All these variables should be considered in relation to the type and size of fire department vehicles available in the municipality or area where the building will be constructed. It is appropriate, therefore, that the local fire department be consulted prior to the design and construction of access routes.

#### **A-3.2.5.7. Water Supply.**

This Article requires that an adequate water supply for firefighting is to be provided for every building. However, farm buildings of low human occupancy under the National Farm Building Code of Canada 1995 are exempted. The water supply requirements for interior fire suppression systems such as sprinkler systems and standpipe and hose systems are contained in other standards, for example, NFPA Standard 13, “Standard for the Installation of Sprinkler Systems”, and NFPA Standard

14, “Standard for the Installation of Standpipe and Hose Systems”. This Appendix note focuses only on water supplies that are considered essential to firefighting by fire department or other trained personnel using fire hoses.

Minimum requirements for water supply for firefighting are relevant mainly to building sites not serviced by municipal water supply systems. For building sites serviced by municipal water supply systems where the water supply duration is not a concern, water supply flow rates at minimum pressures would be the main focus of this Appendix note. However, where municipal water supply capacities are limited, it would be necessary for buildings to have on-site supplemental water supply.

An adequate water supply for firefighting should be an immediately available and accessible water supply with sufficient volume and/or flow to enable fire department personnel using fire hoses to control fire growth until the building is safely evacuated, prevent the fire from spreading to adjacent buildings, limit environmental impact of the fire, and provide a limited measure of property protection.

The sources of water supply for firefighting purposes may be natural or man-made. Natural sources may include ponds, lakes, rivers, streams, bays, creeks, springs, artesian wells, and irrigation canals. Man-made sources may include aboveground tanks, elevated gravity tanks, cisterns, swimming pools, wells, reservoirs, aqueducts, tankers, and hydrants served by a public or private water system. It is imperative that such sources of water be accessible to fire department equipment under all climate conditions.

The available water supply would allow arriving fire department personnel to use the water at their discretion when entering a burning building with hose lines. During the search and evacuation operation, hose streams may be needed for fire suppression to limit fire spread. The duration of the water supply should be sufficient to allow complete search and evacuation of the building. Once the search and rescue operations are complete, additional water may be required for exposure protection or fire suppression to limit property damage.

Fire departments serving remote or rural areas often have to respond to a fire with a transportable water supply of sufficient volume for approximately 5 to 10 minutes when using one or two 38 mm hose lines. This would provide minimal hose streams allowing immediate search and rescue operations in small buildings with simple layouts but limited fire suppression capabilities, especially if a fire is already well-established.

For larger more complex buildings, an on-site water supply for firefighting would be needed to provide an extended duration of hose stream use by the fire department to allow search and evacuation of the building, exposure protection and fire suppression. The volume of this on-site water supply would be dependent on the building size, construction, occupancy, exposure and environmental impact potential, and should be sufficient to allow at least 30 minutes of fire department hose stream use.

The recommendations of this Appendix note are predicated on prompt response by a well-equipped fire department using modern firefighting techniques, and buildings being evacuated in accordance with established building fire safety plans and fire department pre-fire plans. For buildings constructed in areas where fire department response is not expected at all or in a reasonable time, sprinkler protection should be considered to ensure safe evacuation.

Elementary and secondary schools usually have a record of well-established and practiced fire safety plans which would allow complete evacuations within 4 minutes. Because of this and the inherent high level of supervision in these buildings, a reduction of the water supply for firefighting may be considered. It is suggested that the level of reduction should be determined by the local enforcement authority based on the resources and response time of the fire department, and the size and complexity of the buildings.

When designing open, unheated reservoirs as sources of fire protection water, a 600 mm ice depth allowance should be included in the water volume calculations, except where local winter temperature conditions result in a greater ice depth (as typically found on local lakes or ponds). As well, make-up water supplies should be provided to maintain the design volumes, taking into account volume loss due to evaporation during drought periods.

#### 1. Buildings not Requiring an On-Site Water Supply

- (a) A building would not require an on-site water supply for firefighting if the building satisfies the criteria set out in Item 1(b) or Item 1(c) provided that:
  - (i) the building is serviced by a municipal water supply system that satisfies Item 3(b), or

- (ii) the fire department can respond with a transportable water supply of sufficient quantity to allow them to conduct an effective search and evacuation of the building, determined on the basis of other guidelines or standards (such as, NFPA 1142, “Standard on Water Supplies for Suburban and Rural Fire Fighting”).
- (b) A building would not require an on-site water supply for firefighting where all of the following criteria are met:
  - (i) the building area is 200 m<sup>2</sup> or less,
  - (ii) the building height is 2 storeys or less,
  - (iii) the building does not contain a care or detention occupancy,
  - (iv) the building does not require a sprinkler system or a standpipe and hose system,
  - (v) the limiting distance from the property line is at least 13 m if the building contains a high hazard industrial occupancy, and
  - (vi) the building constitutes no significant environmental contamination potential due to fire.
- (c) A building that exceeds 200 m<sup>2</sup> in building area or 2 storeys in building height and that contains a low hazard industrial occupancy may not require an on-site water supply for firefighting if the combustible loading in the building is insignificant (such as that found in cement plants, steel stock storage sheds, etc.), as determined by the chief building official.

## 2. Sprinklered Buildings

For sprinklered buildings, water supply additional to that required by the sprinkler systems should be provided for firefighting using fire hoses in accordance with the hose stream demands and water supply durations for different hazard classifications as specified in NFPA 13, “Installation of Sprinkler Systems”.

## 3. Buildings Requiring On-Site Water Supply

- (a) Except for sprinklered buildings and as required by Items 3(c) and 3(e), buildings should have a supply of water available for firefighting purposes not less than the quantity derived from the following formula:

$$Q = K \cdot V \cdot S_{\text{tot}}$$

where

Q = minimum supply of water in litres

K = water supply coefficient from Table 1

V = total building volume in cubic metres

S<sub>tot</sub> = total of spatial coefficient values from property line exposures on all sides as obtained from the formula:

$$S_{\text{tot}} = 1.0 + [S_{\text{side1}} + S_{\text{side2}} + S_{\text{side3}} + \dots \text{ etc.}]$$

where

S<sub>side</sub> values are established from Figure 1, as modified by Items 3(d) and 3(f), and

S<sub>tot</sub> need not exceed 2.0.

- (b) Water supply flow rates should not be less than that specified in Table 2. Where the water supply is from a municipal or industrial water supply system, the required flow rate should be available at a minimum pressure of 140 kPa.
- (c) The water supply as required in Item 3(a) should not be less than that needed to provide the minimum flow rate specified in Table 2 for a minimum duration of 30 minutes.
- (d) Where a masonry wall with a minimum fire-resistance rating of 2 h, and no unprotected openings is provided as an exterior wall, the spatial coefficient (S<sub>side</sub>) for this side of the building may be considered equal to 0. This masonry wall should be provided with a minimum 150 mm parapet. Firewalls that divide a structure into two or more buildings may be given similar consideration when evaluating the exposure of the buildings to each other.
- (e) In elementary or secondary schools, the water supply determined in accordance with Items 3(a) and 3(b) may be reduced. The level of reduction to be applied would be at the discretion of the local enforcement authority, and should not exceed 30 percent.
- (f) The spatial coefficient S<sub>side</sub> may be considered equal to 0 when the exposed building is on the same property and is less than 10 m<sup>2</sup> in building area.

4. Additions to Existing Buildings

- (a) Except as permitted in Items 4(b) and 4(c), additions to existing buildings should be provided with a water supply for firefighting as required in Items 3(a) to 3(c). Although under Part 11, Renovation, the required water supply is to be based only on the building volume of the addition, it is recommended that the entire building volume of the expanded facility be used to ensure complete evacuation and safety of all the occupants.
- (b) Buildings with new additions falling within any one of the following criteria would not require an additional water supply for firefighting where:
  - (i) the expanded building complies with all the requirements of Item 1(a),
  - (ii) the new addition does not exceed 100 m<sup>2</sup> in building area, or
  - (iii) the new addition exceeds 100 m<sup>2</sup> but does not exceed 400 m<sup>2</sup> in building area, contains an assembly, business and personal services, mercantile or low hazard industrial occupancy, is of noncombustible construction, does not result in a significant increase in exposure to other existing buildings, has no combustible storage or process, and is separated from the existing building by a fire separation with a fire-resistance rating of at least 1 h.
- (c) Where a firewall is provided between the new addition and the existing building, the water supply for firefighting may be determined in accordance with Items 1(a) and 3(a), using only the building volume of the new addition.

Table 1					
Water Supply Coefficient - K					
Type of Construction	Classification by Group or Division in Accordance with Table 3.1.2.1. of the Building Code				
	A-2 B-1 B-2 B-3 C D	A-4 F-3	A-1 A-3	E F-2	F-1
Building is of noncombustible construction with fire separations and fire-resistance ratings provided in accordance with Subsection 3.2.2., including loadbearing walls, columns and arches.	10	12	14	17	23
Building is of noncombustible construction or of heavy timber construction conforming to Article 3.1.4.6. Floor assemblies are fire separations but with no fire-resistance rating. Roof assemblies, mezzanines, loadbearing walls, columns and arches do not have a fire-resistance rating.	16	19	22	27	37
Building is of combustible construction with fire separations and fire-resistance ratings provided in accordance with Subsection 3.2.2., including loadbearing walls, columns and arches. Noncombustible construction may be used in lieu of fire-resistance rating where permitted in Subsection 3.2.2.	18	22	25	31	41
Building is of combustible construction. Floor assemblies are fire separations but with no fire-resistance rating. Roof assemblies, mezzanines, loadbearing walls, columns and arches do not have a fire-resistance rating.	23	28	32	39	53
Column 1	2	3	4	5	6

# OBC Water Supply for Firefighting Calculation

Based on OBC 2012 (Div. B, Article 3.2.5.7)

References: [Ontario Fire Marshal - OBC Fire Fighting Water Supply](#)  
[Ontario Building Code 2012, Appendix A, Vol 2., A-3.2.5.7](#)



**Novatech Project #:** 124111  
**Project Name:** 541 Somme Street  
**Date:** 2/3/2025  
**Input By:** Ryan Good  
**Reviewed By:** Anthony Mestwarp

**Legend**  
 Input by User  
 No Input Required

**Building Description:** Single Storey Industrial - F-3 Classification - Combustible Construction  
 Unsprinklered

Step	Calculation Inputs	Calculation Notes	Value
<b>Minimum Fire Protection Water Supply Volume</b>			
<b>Water Supply Coefficient</b>			
1	Building Classification = F-3 <b>Water Supply Coefficient - K =</b>	From Table 3.1.2.1 From Table 1 (A3.2.5.7)	<b>28</b>
<b>Total Building Volume</b>			
2	Building Width - W	17.00 m	Area (W * L) = 415 m <sup>2</sup>
	Building Length - L	24.40 m	
	Building Height - H	6 m	
	<b>Total Building Volume - V =</b>	W * L * H	<b>2489 m<sup>3</sup></b>
<b>Spatial Coefficient Value</b>			
3	<b>Exposure Distances:</b> (Exterior building face to property/lot line, to street centre, or to mid-point between proposed building and another building on same lot)		<b>Spatial Coefficients:</b> From Figure 1 (Spatial Coefficient vs Exposure Distance)
	North	15.00 m	Sside 1 = 0.00
	East	73.86 m	Sside 2 = 0.00
	South	23.43 m	Sside 3 = 0.00
	West	25.52 m	Sside 4 = 0.00
	<b>Total of Spatial Coefficient Values - S-Tot</b> as obtained from the formula =	1.0 + (Sside 1 + Sside 2 + Sside 3 + Sside 4) (Max. value = 2.0)	<b>1.00</b>
<b>Minimum Fire Protection Water Supply Volume</b>			
4	<b>Q =</b>	$K * V * S_{Tot}$	<b>69,686 L</b>
<b>Required Minimum Water Supply Flow Rate</b>			
5	<b>Minimum Water Supply Flow Rate =</b>	From Table 2 (For water supply from a municipal or industrial water supply system, min. pressure is 140 kPa)	<b>2,700 L/min</b> or <b>45 L/s</b>
<b>Minimum Fire Protection Water Supply Volume for 30 minutes</b>			
6	<b>Q =</b>	= Minimum Water Supply Flow Rate (L/min) * 30 minutes	<b>81,000 L</b>
<b>Required Fire Protection Water Supply Volume</b>			
7	<b>Q =</b>	Highest volume out of (4) and (6)	<b>81,000 L</b>
Notes			

**From:** Evans, Allan <Allan.Evans@ottawa.ca>

**Sent:** Thursday, February 27, 2025 9:46 AM

**To:** Ryan Good <r.good@novatech-eng.com>

**Cc:** Greg MacDonald <g.Macdonald@novatech-eng.com>; Anthony Mestwarp <a.mestwarp@novatech-eng.com>; Whittaker, Damien <Damien.Whittaker@ottawa.ca>

**Subject:** RE: 541 Somme Street - On-Site Fire Supply Coordination

Hi Ryan – I concur that OFS will not request a fire water storage tank based upon the information provided.

Building code services is the AHJ so ultimately it will be their final decision. I have cc'd Damien so that he has my comments on record – this may not be his file however so I am hoping he can forward to the appropriate person within his division as needed.

A

**Allan Evans**

**Fire Protection Engineer / Ingénieur de Protection d'Incendies**

**Prevention Division / Prévention des Incendies**

**Ottawa Fire Services / Service des Incendies d'Ottawa**

**1445 Carling Avenue / 1445 Avenue Carling**

**Ottawa, ON K1Z 7L9**

**Allan.Evans@[Ottawa.ca](mailto:Ottawa.ca)**

**(( 613) 913-2747 | (( 613) 580-2424 x24119 | 6 (613) 580-2866 | + Mail Code: 25-102 | @OFSFPE**



An internationally accredited agency 2019-2024



**OTTAWA FIRE SERVICES**  
**SERVICE DES INCENDIES D'OTTAWA**

*Protecting Our Nation's Capital With Honour*  
*Protéger notre capitale nationale avec honneur*

Classified as City of Ottawa - Internal / Ville d'Ottawa - classé interne

**From:** Ryan Good <[r.good@novatech-eng.com](mailto:r.good@novatech-eng.com)>

**Sent:** February 27, 2025 9:38 AM

**To:** Evans, Allan <[Allan.Evans@ottawa.ca](mailto:Allan.Evans@ottawa.ca)>

**Cc:** Greg MacDonald <[g.Macdonald@novatech-eng.com](mailto:g.Macdonald@novatech-eng.com)>; Anthony Mestwarp <[a.mestwarp@novatech-eng.com](mailto:a.mestwarp@novatech-eng.com)>

**Subject:** 541 Somme Street - On-Site Fire Supply Coordination

Hi Allan,

Please note we are working on an Industrial Site Plan development at 541 Somme Street, in the Hawthorne Industrial Park; the City identified you as the OFS contact for coordination. The following are details relating to the project (see attached building plans which include the building statistics and Siteplan for general site layout):

- The intended building use is an office space at the front of the building and a warehouse at the back of the building
- Building Area = 416.2m<sup>2</sup>
- Major Occupancy Classifications are Group D (107.95m<sup>2</sup>) and Group F3 (293.1m<sup>2</sup>)

We are currently proposing that no on-site water supply storage is required for firefighting purposes, on the basis that the building is less than 600m<sup>2</sup> and Low Hazardous Industrial occupancy. This is consistent with the approach our team coordinated with you the Techo Bloc development (also <600m<sup>2</sup> and Low Industrial occupancy) located at 581 Somme Street.

Let us know if you have any comments or concerns with the details above. If a meeting would be helpful to discuss any details, please confirm a time you are available and we can schedule a Teams meeting.

Thank you,

**Ryan Good**, C.E.T., Design Technologist | Land Development and Public Sector Infrastructure

**NOVATECH**

Engineers, Planners & Landscape Architects

240 Michael Cowpland Drive, Suite 200, Ottawa, ON, K2M 1P6 | Tel: 613.254.9643 Ext: 284 | Cell: 343-364-2246

**From:** Erik Ardley <EArdley@patersongroup.ca>

**Sent:** Thursday, May 1, 2025 2:14 PM

**To:** Michael Killam <MKillam@patersongroup.ca>; Ryan Good <r.good@novatech-eng.com>; Alex Schopf <aschopf@patersongroup.ca>

**Cc:** Jeffrey Kelly <j.kelly@novatech-eng.com>; Anthony Mestwarp <a.mestwarp@novatech-eng.com>; Lucky Montierro <lucky.montierro@titanenviro.com>; Greg MacDonald <g.Macdonald@novatech-eng.com>

**Subject:** RE: PH4991 - 541 Somme Street - Well location survey and Water Requirements

Good afternoon Ryan,

We were able to complete the meeting with the City Hydrogeologist today. They agree with the approach of using the well as a non-drinkable water source and have not asked for anything further. As such, we are wrapping up the report and anticipate having it to you for the end of next week.

Please do not hesitate to reach out should you have any questions or concerns,

Thanks,

Erik



**ERIK ARDLEY, P.Geo.**

Project Manager – Hydrogeology

TEL: (613) 808-9776

9 AURIGA DRIVE

OTTAWA ON K2E 7T9

[patersongroup.ca](http://patersongroup.ca)

**From:** Alex Schopf <aschopf@patersongroup.ca>  
**Sent:** Wednesday, March 26, 2025 10:49 AM  
**To:** Greg MacDonald <g.Macdonald@novatech-eng.com>; Juice Lambert <juice.lambert@titanenviro.com>; Lucky Montierro <lucky.montierro@titanenviro.com>; Ryan Good <r.good@novatech-eng.com>; Michael Killam <MKillam@patersongroup.ca>  
**Cc:** Jeffrey Kelly <j.kelly@novatech-eng.com>; Anthony Mestwarp <a.mestwarp@novatech-eng.com>; Erik Ardley <Eardley@patersongroup.ca>  
**Subject:** RE: PH4991 – 541 Somme Street – Well location survey and Water Requirements

Hi Greg,

While it has been accepted in the past, the City has indicated that it is on a case-by-case basis and therefore it would need to be confirmed with the City before having potable water brought in is proposed in the report. With the clients permission we will reach out to the City to initiate the discussion.

Cheers,



**Alexander Schopf, E.I.T, PhD**

Hydrogeology Department

TEL: (613) 226-7381 ext. 136

DIRECT: (613) 912-3490

CELL: (613) 807-4147

9 AURIGA DRIVE

OTTAWA ON K2E 7T9

[patersongroup.ca](http://patersongroup.ca)

**From:** Greg MacDonald <g.Macdonald@novatech-eng.com>  
**Sent:** Wednesday, March 26, 2025 9:27 AM  
**To:** Alex Schopf <aschopf@patersongroup.ca>; Juice Lambert <juice.lambert@titanenviro.com>; Lucky Montierro <lucky.montierro@titanenviro.com>; Ryan Good <r.good@novatech-eng.com>; Michael Killam <MKillam@patersongroup.ca>  
**Cc:** Jeffrey Kelly <j.kelly@novatech-eng.com>; Anthony Mestwarp <a.mestwarp@novatech-eng.com>; Erik Ardley <Eardley@patersongroup.ca>  
**Subject:** RE: PH4991 - 541 Somme Street - Well location survey and Water Requirements

Thanks Alex. Will the City accept this, e.g. potable water brought in?

**Greg MacDonald, P. Eng.**

Director, Land Development and Public Sector Infrastructure

**NOVATECH**

Engineers, Planners & Landscape Architects

240 Michael Cowpland Drive, Suite 200, Ottawa, ON, K2M 1P6 | Tel: 613.254.9643 x279 | Cell: 613.890.9705 | Fax: 613.254.5867

**From:** Alex Schopf <[aschopf@patersongroup.ca](mailto:aschopf@patersongroup.ca)>

**Sent:** Wednesday, March 26, 2025 9:20 AM

**To:** Juice Lambert <[juice.lambert@titanenviro.com](mailto:juice.lambert@titanenviro.com)>; Lucky Montierro

<[lucky.montierro@titanenviro.com](mailto:lucky.montierro@titanenviro.com)>; Ryan Good <[r.good@novatech-eng.com](mailto:r.good@novatech-eng.com)>; Greg MacDonald <[g.Macdonald@novatech-eng.com](mailto:g.Macdonald@novatech-eng.com)>; Michael Killam <[MKillam@patersongroup.ca](mailto:MKillam@patersongroup.ca)>

**Cc:** Jeffrey Kelly <[j.kelly@novatech-eng.com](mailto:j.kelly@novatech-eng.com)>; Anthony Mestwarp <[a.mestwarp@novatech-eng.com](mailto:a.mestwarp@novatech-eng.com)>; Erik Ardley <[EArdley@patersongroup.ca](mailto:EArdley@patersongroup.ca)>

**Subject:** RE: PH4991 - 541 Somme Street - Well location survey and Water Requirements

Good morning Juice and Lucky,

We received the geochemical results from the pumping test. Unfortunately the geochemical results indicate that the water supply encountered by the well is non potable and has encountered potential surficial impacts. The most significant issues are the presence of total coliforms, a dissolved organic carbon concentration of 7.7 mg/L, and a manganese concentration of approximately 2.9 mg/L.

The presence of total coliforms and dissolved organic carbon is typically associated with surficial impacts, however can be associated with potential impacts during the well installation process. In order to determine if the total coliforms are associated with the well installation or with the aquifer, the well will need to be disinfected and purged, after which a resample will need to be collected. This will require renting a pump trailer from Air Rock for two days, one to chlorinate the well and one to purge it. Prior to completing any further work, we recommend that we complete a Hydrogeological consultation with the City Hydrogeologists to ensure that they will accept our proposed approach. We can complete the work on a time and materials basis to keep costs down.

Under the City of Ottawa Hydrogeological Assessment and Terrain Analysis Guidelines (HTAG) annotated Ministry of the Environment, Conservation and Parks (MECP) Procedure D-5-5, the Maximum Concentration Considered Reasonably Treatable (MCCRT) for manganese is 1.0 mg/L. Under the current Federal Guidelines, manganese has a Maximum Acceptable Concentration (MAC) of 0.12 mg/L. The manganese concentration which was measured is approximately 2.89 mg/L, which is approximately 24 times higher than the federal MAC of 0.12 mg/L and approximately 2.5 times the provincial MCCRT. As the manganese concentration is greater than the MCCRT, the Hydrogeological Assessment in support of the Site Plan application would indicate that the water supply could not be used for potable uses (i.e drinking water).

Assuming that the potential surficial impacts are associated with the well installation process, we would still need to address the elevated manganese concentration in the aquifer. This means that regardless of the bacteria presence, the water source cannot be used for drinking water purposes. Additional drinking water (i.e water coolers) would need to be brought in from off site, however the well water can still be used for non-potable uses such as toilets.

Please let us know when you are available to discuss.



**Alexander Schopf, E.I.T, PhD**

Hydrogeology Department

TEL: (613) 226-7381 ext. 136

DIRECT: (613) 912-3490

CELL: (613) 807-4147

9 AURIGA DRIVE

OTTAWA ON K2E 7T9

[patersongroup.ca](http://patersongroup.ca)

## Appendix C

### Sanitary Design Information

(6) Water softener and iron filter discharge may be directed to the *sewage system* provided the system has been designed to accept such discharges.

(7) *Storm sewage* shall not be discharged into a *sewage system*.

- (8) The *interceptor* required in Sentence (4) shall,
- (a) have a minimum flow rate as required by Sentence 7.4.4.3.(8) using a 60 second drain down time, and
  - (b) conform to,
    - (i) CSA B481.1, “Testing and Rating of Grease Interceptors Using Lard”, or
    - (ii) CSA B481.2, “Testing and Rating of Grease Interceptors Using Oil”.

## Section 8.2. Design Standards

### 8.2.1. General Requirements

#### 8.2.1.1. Scope

- (1) This Subsection applies to the design of *sewage systems*.

#### 8.2.1.2. Site Evaluation

(1) A site evaluation shall be conducted on every site where a new or replacement *sewage system* is to be installed. (See Appendix A.)

- (2) The *percolation time* shall be determined by,
- (a) conducting percolation tests, or
  - (b) classifying the *soil* according to one of the following methods,
    - (i) the Unified Soil Classification System as described in MMAH Supplementary Standard SB-6, “Percolation Time and Soil Descriptions”, or

- (ii) the Soil Texture Classification as described in Chapter 3 of USDA, "Soil Survey Manual". (See Appendix A.)

(3) Where the *percolation time* is determined by a percolation test, there shall be a minimum of 3 locations selected, suitably spaced to accurately evaluate the *leaching bed* area, with the highest *percolation time* of the tests being used. (See Appendix A.)

### 8.2.1.3. Sewage System Design Flows

(1) For *residential occupancies*, the total daily design *sanitary sewage* flow shall be at least the value in Column 2 as determined from Table 8.2.1.3.A. (See Appendix A.)

(2) For all other *occupancies*, the total daily design *sanitary sewage* flow shall be at least the value in Column 2 as determined from Table 8.2.1.3.B. (See Appendix A.)

(3) Where a *building* contains more than one establishment, the total daily design *sanitary sewage* flow shall be the sum of the total daily design *sanitary sewage* flow for each establishment.

(4) Where an *occupancy* is not listed in Table 8.2.1.3.B., the highest of metered flow data from at least 3 similar establishments shall be acceptable for determining the total daily design *sanitary sewage* flow.

**Table 8.2.1.3.A.**  
**Residential Occupancy**  
 Forming Part of Sentence 8.2.1.3.(1)

<i>Residential Occupancy</i>	Volume, litres
Apartments, Condominiums, Other Multi-family Dwellings - per person <sup>(1)</sup>	275
Boarding Houses	
(a) Per person,	
(i) with meals and laundry facilities, or,	200
(ii) without meal or laundry facilities, and	150
(b) Per non-resident staff per 8 hour shift	40
Boarding School - per person	300
Dwellings	
(a) 1 bedroom dwelling	750
(b) 2 bedroom dwelling	1 100
(c) 3 bedroom dwelling	1 600
(d) 4 bedroom dwelling	2 000
(e) 5 bedroom dwelling	2 500
(f) Additional flow for <sup>(2)</sup>	
(i) each bedroom over 5,	500
(ii) (A) each 10 m <sup>2</sup> (or part of it) over 200 m <sup>2</sup> up to 400 m <sup>2</sup> <sup>(3)</sup> ,	100
(B) each 10 m <sup>2</sup> (or part of it) over 400 m <sup>2</sup> up to 600 m <sup>2</sup> <sup>(3)</sup> , and	75
(C) each 10 m <sup>2</sup> (or part of it) over 600 m <sup>2</sup> <sup>(3)</sup> , or	50
(iii) each fixture unit over 20 fixture units	50
Hotels and Motels (excluding bars and restaurants)	
(a) Regular, per room	250
(b) Resort hotel, cottage, per person	500
(c) Self service laundry, add per machine	2 500
Work Camp/Construction Camp, semi-permanent per worker	250
Column 1	2

**Notes to Table 8.2.1.3.A.:**

- (1) The *occupant load* shall be calculated using Subsection 3.1.17.
- (2) Where multiple calculations of *sanitary sewage* volume is permitted, the calculation resulting in the highest flow shall be used in determining the design daily *sanitary sewage* flow.
- (3) Total finished area, excluding the area of the finished *basement*.

**Table 8.2.1.3.B.**  
**Other Occupancies**  
 Forming Part of Sentence 8.2.1.3.(2)

Establishments <sup>(1)</sup>	Volume, litres
Airports, Bus Terminals, Train Stations, Dock/Port Facilities (Food Services excluded)	
(a) Per passenger, and	20
(b) Per employee per 8 hour shift	40
Assembly Hall - per seat	
(a) No food service, or	8
(b) Food service provided	36
Barber Shop/Beauty Salon - per service chair	650
Bowling Alleys (Food Service not included) - per lane	400
Churches and Similar Places of Worship - per seat	
(a) No kitchen facilities, or	8
(b) Kitchen facilities provided	36
Country Club (excluding Food Service)	
(a) Per resident,	375
(b) Per employee per 8 hour shift, and	50
(c) Per member or patron	40
Day Care Facility per person (staff and children)	75
Dentist Office	
(a) Per wet service chair, and	275
(b) Per dry service chair	190
Doctors Office	
(a) Per practitioner, and	275
(b) Per employee per 8 hour shift	75
Factory (excluding process or cleaning waters) - per employee per 8 hour shift	
(a) No showers, or	75
(b) Including showers	125
Flea Markets <sup>(2)</sup> (open not more than 3 days per week)	
(a) Per non-food service vendor space,	60
(b) Per food service establishment / 9.25 m <sup>2</sup> of floor space, and	190
(c) Per limited food service outlet	95
Column 1	2

**Table 8.2.1.3.B. (Cont'd)**  
**Other Occupancies**  
 Forming Part of Sentence 8.2.1.3.(2)

Establishments <sup>(1)</sup>	Volume, litres
<b>Food Service Operations</b>	
(a) Restaurant (not 24 hour), per seat	125
(b) Restaurant (24 hour), per seat	200
(c) Restaurant on controlled-access highway, per seat	400
(d) Paper service restaurant, per seat	60
(e) Donut shop, per seat	400
(f) Bar and cocktail lounge, per seat	125
(g) Drive-in restaurant per parking space	60
(h) Take-out restaurant (no seating area)	
(i) per 9.25 m <sup>2</sup> of floor area, and	190
(ii) per employee per 8 hour shift	75
(i) Cafeteria - per meal	12
(j) Food outlet	
(i) excluding delicatessen, bakery and meat department, per 9.25 m <sup>2</sup> of floor space,	40
(ii) per 9.25 m <sup>2</sup> of delicatessen floor space,	190
(iii) per 9.25 m <sup>2</sup> of bakery floor space,	190
(iv) per 9.25 m <sup>2</sup> of meat department floor space, and	380
(v) per water closet	950
<b>Hospitals - per bed</b>	
(a) Including laundry facilities, or	750
(b) Excluding laundry facilities	550
<b>Long-Term Care Homes, etc. - per bed</b>	450
<b>Office Building<sup>(3)</sup></b>	
(a) Per employee per 8 hour shift, or	75
(b) Per each 9.3 m <sup>2</sup> of floor space	75
<b>Public Parks</b>	
(a) With toilets only per person, or	20
(b) With bathhouse, showers, and toilets per person	50
Column 1	2

**Table 8.2.1.3.B. (Cont'd)**  
**Other Occupancies**  
 Forming Part of Sentence 8.2.1.3.(2)

Establishments <sup>(1)</sup>	Volume, litres
Recreational Vehicle or Campground Park	
(a) Per site without water or sewer hook-up, or	275
(b) Per site with water and sewer hook-up	425
Schools - per student	
(a) Day school,	30
(b) With showers,	30
(c) With cafeteria, and	30
(d) Per non-teaching employee per 8 hour shift	50
Service Stations (no vehicle washing) <sup>(3)</sup>	
(a) Per water closet, and	950
(i) per fuel outlet <sup>(4)</sup> , or	560
(ii) per vehicle served	20
Shopping Centre (excluding food and laundry) - per 1.0 m <sup>2</sup> of floor space	5
Stadiums, Race Tracks, Ball Parks - per seat	20
Stores <sup>(3)</sup>	
(a) Per 1.0 m <sup>2</sup> of floor area, or	5
(b) Per water closet	1 230
Swimming and Bathing Facilities (Public) - per person	40
<i>Theatres</i>	
(a) Indoor, auditoriums per seat,	20
(b) Outdoor, drive-ins per space, or	40
(c) Movie theatres per seat	15
Veterinary Clinics	
(a) Per practitioner,	275
(b) Per employee per 8 hour shift, and	75
(c) Per stall, kennel or cage if floor drain connected	75
Warehouse	
(a) Per water closet, and	950
(b) Per loading bay	150
Column 1	2

**Notes to Table 8.2.1.3.B.:**

- (1) The *occupant load* shall be calculated using Subsection 3.1.17.
- (2) Flea markets open more than 3 days per week shall be assessed using the volumes stated under the heading "Stores".
- (3) Where multiple calculations of *sanitary sewage* volume is permitted, the calculation resulting in the highest flow shall be used in determining the design daily *sanitary sewage* flow.
- (4) The number of fuel outlets is considered the maximum number of fuel nozzles that could be in use at the same time.

**8.2.1.4. Clearances (See Appendix A.)**

(1) Unless it can be shown to be unnecessary, where the *percolation time* is 10 minutes or greater, the location of all components within a *sewage system* shall be in conformance with the clearances listed in Article 8.2.1.5. or 8.2.1.6.

(2) Unless it can be shown to be unnecessary, where the *percolation time* is less than 10 minutes, the clearances listed in Articles 8.2.1.5. and 8.2.1.6. for wells, lakes, ponds, reservoirs, rivers, springs or streams shall be increased to compensate for the lower *percolation time*.

(3) No *building* shall be *constructed* closer to any part of a *sewage system* than the clearances listed in Article 8.2.1.5. or 8.2.1.6.

(4) If more than one *sewage system* is located on a lot or parcel of land, there shall be no overlap of any part of the systems.

**8.2.1.5. Clearance Distances for Class 1, 2 and 3 Sewage Systems**

(1) Except as provided in Sentences 8.2.1.4.(1) and (2), no Class 1, 2 or 3 *sewage system* shall have a horizontal distance of less than that permitted by Table 8.2.1.5.

**Table 8.2.1.5.**  
**Clearance Distances for Class 1, 2 and 3 Sewage Systems**  
 Forming Part of Sentence 8.2.1.5.(1)

<i>Sewage System</i>	Minimum horizontal distance in metres from a well with watertight casing to a depth of at least 6 m	Minimum horizontal distance in metres from a spring used as a source of <i>potable water</i> , or well other than a well with a watertight casing to a depth of at least 6 m	Minimum horizontal distance in metres from a lake, river, pond, stream, reservoir, or a spring not used as a source of <i>potable water</i>	Minimum horizontal distance in metres from a property line
<i>Earth Pit Privy</i>	15	30	15	3
<i>Privy Vault Pail Privy</i>	10	15	10	3
<i>Greywater System</i>	10	15	15	3
<i>Cesspool</i>	30	60	15	3
Column 1	2	3	4	5

### 8.2.1.6. Clearances for a Class 4 or 5 Sewage System

- (1) Except as provided in Sentences 8.2.1.4.(1) and (2), a *treatment unit* shall not be located closer than the minimum horizontal distances set out in Table 8.2.1.6.A.
- (2) Except as provided in Sentences 8.2.1.4.(1) and (2), the centreline of a *distribution pipe* or *leaching chamber* shall not be located closer than the minimum horizontal distances set out in Table 8.2.1.6.B. and these distances shall be increased when required by Sentence 8.7.4.2.(11).
- (3) Except as provided in Sentences 8.2.1.4.(1) and (2), a *holding tank* shall not be located closer than the minimum horizontal distances set out in Table 8.2.1.6.C.

**Table 8.2.1.6.A.**  
**Minimum Clearances for Treatment Units**  
 Forming Part of Sentence 8.2.1.6.(1)

Object	Minimum Clearance, m
Structure	1.5
Well	15
Lake	15
Pond	15
Reservoir	15
River	15
Spring	15
Stream	15
Property Line	3
Column 1	2

**Table 8.2.1.6.B.**  
**Minimum Clearances for Distribution Piping and Leaching Chambers**  
 Forming Part of Sentence 8.2.1.6.(2)

Object	Minimum Clearance, m
Structure	5
Well with a watertight casing to a depth of at least 6 m	15
Any other well	30
Lake	15
Pond	15
Reservoir	15
River	15
Spring not used as a source of <i>potable water</i>	15
Stream	15
Property Line	3
Column 1	2

Division B / Part 8

**Table 8.2.1.6.C.**  
**Minimum Clearances for Holding Tanks**  
 Forming Part of Sentence 8.2.1.6.(3)

Object	Minimum Clearance, m
Structure	1.5
Well with a watertight casing to a depth of at least 6 m	15
Any other well	15
Spring	15
Property Line	3
Column 1	2

## **8.2.2. Treatment and Holding Tanks**

### **8.2.2.1. Application**

(1) This Subsection applies to any tank used in a *sewage system* for collecting, treating, holding or storing *sanitary sewage*.

### **8.2.2.2. Tanks**

(1) Subject to Sentence (3), a tank that is used as a *treatment unit* in a Class 4 *sewage system* or a *holding tank* in a Class 5 *sewage system* shall conform to the requirements of CSA B66, “Design, Material, and Manufacturing Requirements for Prefabricated Septic Tanks and Sewage Holding Tanks”.

(2) Subject to Sentence (3), material standards, access and construction methods and practices for a tank used for other Classes of *sewage systems* shall conform to the requirements of CSA B66, “Design, Material, and Manufacturing Requirements for Prefabricated Septic Tanks and Sewage Holding Tanks”.

- (3) Tanks referred to in Sentences (1) and (2) are not required to conform to the requirements of Clause 10.2.(j) of CSA B66 “Design, Material, and Manufacturing Requirements for Prefabricated Septic Tanks and Sewage Holding Tanks”.
- (4) Sentence (2) does not apply to a tank that is an integral part of a prefabricated Class 1 *sewage system*.
- (5) Access openings shall be located to facilitate the pumping of all compartments and the servicing of the inlet and outlet of each compartment not accessible by removal of the tank top or part of it.
- (6) A tank shall not be covered by *soil* or *leaching bed fill* having a depth greater than the maximum depth of burial that the tank is designed to withstand.
- (7) A tank shall be securely anchored when located in an area subject to flooding or where *ground water* levels may cause hydrostatic pressures.

### 8.2.2.3. Septic Tanks

- (1) The minimum *working capacity* of a *septic tank* shall be the greater of 3 600 L and,
- (a) in *residential occupancies*, twice the daily design *sanitary sewage* flow, or
  - (b) in *non-residential occupancies*, three times the daily design *sanitary sewage* flow.
- (2) Every *septic tank* shall be constructed in such a manner that any *sanitary sewage* flowing through the tank will pass through at least 2 compartments.
- (3) The *working capacity* of the compartments required in Sentence (2) shall be sized such that,
- (a) the first compartment is at least 1.3 times the daily design *sanitary sewage* flow but in no case less than 2 400 L, and

- (b) each subsequent compartment shall be at least 50% of the first compartment.
- (4)** Where multiple tanks are to be used to meet the requirements of Sentences (2) and (3), the tanks shall be connected in series such that,
- (a) the first tank in the series shall have at least a capacity as calculated in Clause (3)(a), however at no time shall a tank having a *working capacity* of less than 3 600 L be used,
  - (b) all additional tanks after the first tank, excluding pump or dosing tanks shall have at least a *working capacity* equal to the volume required by Clause (3)(b),
  - (c) the pipe between the outlet of one tank and the inlet of the next tank in the series shall have a minimum slope of 2 percent,
  - (d) there shall be no partitions in the tank except where a partition is required to maintain the structural integrity of the tank, in which case openings within the partition shall be provided to allow the free movement of *sanitary sewage* throughout the tank, and
  - (e) all piping between tanks shall be continuous and shall be connected to the tank through the use of flexible watertight seals that will permit differential movement between the tanks.
- (5)** Partitions separating the *septic tank* into compartments shall extend at least 150 mm above the liquid level at the outlet, and there shall be one or more openings through or above the partition.
- (6)** The openings required between compartments referred to in Sentence (2) shall have a total cross-sectional area of at least three times the area of the inlet pipe and be located between the top and a level 150 mm above the liquid level at the outlet to provide for the free flow of air between compartments.

- (7)** *Sanitary sewage* shall pass from one compartment to another of the *septic tank* as follows:
- (a) by means of a device similar to that described in CSA B66, “Design, Material, and Manufacturing Requirements for Prefabricated Septic Tanks and Sewage Holding Tanks” for outlet devices, or
  - (b) through two or more openings through the partition located in a horizontal line, and evenly spaced across the width of the partition, centred at approximately 40% of the liquid depth below the surface of the liquid, and having a total area of between three and five times that of the cross-sectional area of the inlet pipe.
- (8)** A *septic tank* shall be of such design and construction as will permit the collection and holding of *sanitary sewage* in it to a depth of not less than 1 000 mm, except that a depth of not less than 900 mm is permitted where the excavation is in rock, or to avoid rupture or displacement of the tank due to *ground water* pressure.
- (9)** Except as provided in Sentences (10) and (11), every *septic tank* shall be installed in such a manner that the access openings are located not more than 300 mm below the ground surface.
- (10)** Where the top of the *septic tank* is located more than 300 mm below the ground surface, it shall be equipped with risers that extend from the access opening of the *septic tank* to within 300 mm of the ground surface.
- (11)** Where risers are used they shall conform to the requirements of CSA B66, “Design, Material, and Manufacturing Requirements for Prefabricated Septic Tanks and Sewage Holding Tanks”, and shall have adequate access openings to allow for regular maintenance of the *septic tank*.

### 8.2.2.4. Holding Tanks

- (1) All *holding tanks* shall be of such design and construction as will allow the complete removal of solid matter that can be expected to settle in the *holding tank* through an apparatus or device suitable for allowing the contents of the *holding tank* to be removed from the *holding tank*.
- (2) A *holding tank* shall have a *working capacity* of not less than 9 000 L.
- (3) Where two or more tanks are used to meet the requirement of Sentence (2), they shall be deemed to be one *holding tank* provided they are connected in such a manner as will allow the *sanitary sewage* contained in them to flow between the tanks.
- (4) The *working capacity* of the tanks described in Sentence (3) shall not include any portion of any tank that cannot be completely drained due to the manner in which the connections are made.

## Section 8.3. Class 1 Sewage Systems

### 8.3.1. General Requirements

#### 8.3.1.1. Scope

- (1) This Section applies to the *construction* of a Class 1 *sewage system*.

#### 8.3.1.2. Application

- (1) Except as provided in Sentence (2), a Class 1 *sewage system* shall be designed to receive only human body waste for disposal.

**Table 8.6.2.2.**  
**Other Treatment Unit Effluent Quality Criteria**  
 Forming Part of Sentences 8.6.2.2.(1) and (2)

Classification of <i>Treatment Unit</i> <sup>(1)</sup>	Suspended Solids <sup>(2)</sup>	CBOD <sub>5</sub> <sup>(2)</sup>
Level II	30	25
Level III	15	15
Level IV	10	10
Column 1	2	3

**Notes to Table 8.6.2.2.:**

(1) The classifications of *treatment units* specified in Column 1 correspond to the levels of treatment described in CAN/BNQ 3680-600, "Onsite Residential Wastewater Treatment Technologies".

(2) Maximum concentration in mg/L based on a 30 day average.

**(3)** All *treatment units* referred to in Sentences (1) and (2) that contain mechanical components shall be equipped with an audible and visual warning alarm so located to warn the occupants of the *building* served or the operator of the *treatment unit* of a malfunction in the operation of the *treatment unit*.

**(4)** All *treatment units* referred to in Sentences (1) and (2) shall permit the sampling of the *effluent*.

**(5)** A *treatment unit* is deemed to comply with Sentences (1) and (2) if it has been certified to CAN/BNQ 3680-600, "Onsite Residential Wastewater Treatment Technologies" using a temperature condition listed under option a) or b) of Clause 8.2.2. of that standard. (See Appendix A.)

**(6)** Every operator of a *treatment unit* shall obtain, from the manufacturer or distributor of the *treatment unit*, literature that describes the unit in detail and provides complete instructions regarding the operation, servicing, and maintenance requirements of the unit and its related components necessary to ensure the continued proper operation in accordance with the original design and specifications.

## 8.7.7. Type A Dispersal Beds

### 8.7.7.1. Construction Requirements

- (1) The *treatment unit* used in conjunction with a *leaching bed constructed as a Type A dispersal bed* shall provide an *effluent* quality that does not exceed the maximum concentrations set out opposite a Level IV *treatment unit* in Columns 2 and 3 of Table 8.6.2.2.
- (2) A *Type A dispersal bed* shall be backfilled with *leaching bed fill* so as to ensure that, after the *leaching bed fill* settles, the surface of the *leaching bed* will not form any depressions.
- (3) The combined thickness of the sand layer and the stone layer if utilized of a *Type A dispersal bed* shall not be less than 500 mm.
- (4) Except as provided in Sentence (5), the sand layer shall,
- (a) be comprised of sand that has,
    - (i) a *percolation time* of at least 6 and not more than 10 min, and
    - (ii) not more than 5% fines passing through a 0.074 mm (No. 200) sieve,
  - (b) have a minimum thickness of 300 mm, and
  - (c) have an area that is not less than the lesser of,
    - (i) the area of the stone layer determined in accordance with Sentence (6) or, if *leaching chambers* are used, the area over which the *leaching chambers* are spaced determined in accordance with Sentence (6.1), and
    - (ii) the value determined by the formula,

$$A = \frac{QT}{850}$$

where,

A = the area of contact in square metres between the base of the sand and the underlying *soil*,

Q = the total daily design *sanitary sewage* flow in litres, and

T = the lesser of 50 and the *percolation time* of the underlying *soil*.

**(5)** Where the underlying *soil* has a *percolation time* of more than 15 min, the sand layer referred to in Sentence (4) shall,

- (a) extend to at least 15 m beyond the perimeter of the *treatment unit*, or the centrelines of the outer *distribution pipes* or or *leaching chambers* if utilized, in any direction in which the *effluent* entering the *soil* or *leaching bed fill* will move horizontally, and
- (b) have an area that is not less than the value determined by the formula,

$$A = \frac{QT}{400}$$

where,

A = the area of contact in square metres between the base of the sand and the underlying *soil*, or *leaching bed fill* if utilized,

Q = the total daily design *sanitary sewage* flow in litres, and

T = the lesser of 50 and the *percolation time* of the underlying *soil*.

(See Appendix A.)

**(6)** Where a stone layer is used, the stone layer shall,

- (a) be rectangular in shape with the long dimension parallel to the site contours,
- (b) have a minimum thickness of 200 mm,
- (c) be protected in the manner described in Sentence 8.7.3.3.(2), and
- (d) be *constructed* such that the bottom of the stone layer is at least 600 mm above the *high ground water table*, rock or *soil* with a *percolation time* of 1 min or less or greater than 50 min.

- (e) have a minimum area not less than the value determined by the formula,

$$A = Q/B$$

where,

A = the area of the stone layer in square metres,

B = the following amount,

- (i) 50, if the total daily design *sanitary sewage* flow exceeds 3 000 litres, or
- (ii) 75, if the total daily design *sanitary sewage* flow does not exceed 3 000 litres, and

Q = the total daily design *sanitary sewage* flow in litres.

**(6.1)** Where *leaching chambers* are used,

- (a) the *Type A dispersal bed* shall be rectangular in shape with the long dimension parallel to the site contours, and
- (b) the *leaching chambers* shall,
  - (i) be evenly spaced over the area calculated in Subclause (iv), with a maximum distance of 200 mm between the exterior edges of the lines of *leaching chamber*,
  - (ii) be protected in the manner described in Clause 8.7.3.4.(1)(f),
  - (iii) be *constructed* such that the bottom of the *leaching chambers* is at least 600 mm above the *high ground water table*, rock or soil with a *percolation time* of 1 min or less or greater than 50 min, and
  - (iv) have a minimum area not less than the value determined by the formula,

$$A = Q/B$$

where,

A = the area over which the *leaching chambers* are spaced, in square metres,

- B = the following amount,
- (i) 50, if the total daily design *sanitary sewage* flow exceeds 3 000 litres, or
  - (ii) 75, if the total daily design *sanitary sewage* flow does not exceed 3 000 litres, and

Q = the total daily design *sanitary sewage* flow in litres.

(7) *Leaching bed fill* with a *percolation time* not exceeding 15 min may be used to satisfy the vertical separation requirements of Clause (6)(d) or Subclause (6.1)(b)(iii), provided that the *leaching bed fill* conforms to the requirements specified in Sentence (5) regardless of the *percolation time* of the underlying *soil*.

(8) Where a stone layer is used, the *effluent* shall be evenly distributed within the stone layer to within 600 mm of the perimeter of the stone layer. (See Appendix A.)

(8.1) Where *leaching chambers* are used, the *effluent* shall be evenly distributed within the area over which the *leaching chambers* are spaced to within 600 mm of the perimeter of that area.

(9) The stone layer or area over which the *leaching chambers* are spaced shall not be located closer than the minimum horizontal distances set out in Table 8.2.1.6.B. and these distances shall be increased when required by Sentence 8.7.4.2.(11).

## 8.7.8. Type B Dispersal Beds

### 8.7.8.1. General Requirements

(1) Except as provided in Sentence (2) and Sentence 8.7.8.2.(2), a *Type B dispersal bed* shall conform to the requirements of Article 8.7.2.1.

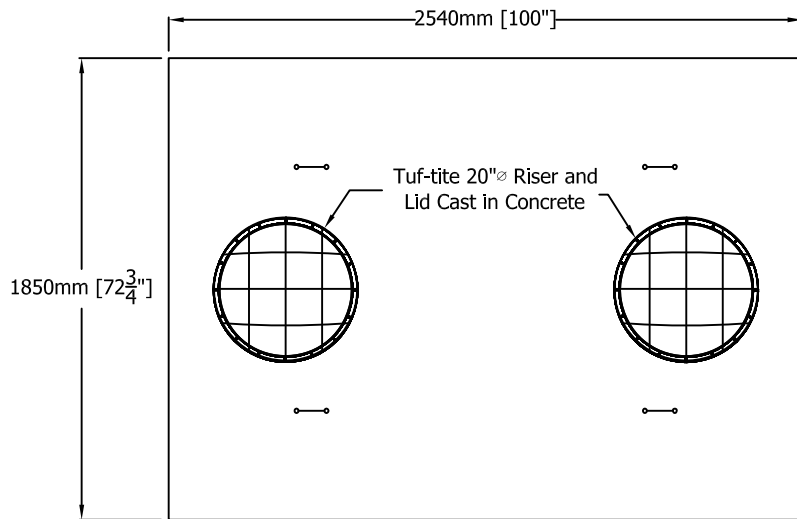

WORKING VOLUME to liquid depth: 4800L (1050 GAL)  
 TOTAL VOLUME to underside of lid: 5700L (1250 GAL)

CONCRETE: 32MPa @ 28 DAYS WITH 5-8% AIR-ENTRAINMENT  
 NON-SULPHATE RESISTANT

REINFORCEMENT: 10M DEFORMED BAR W/MIN 25mm (1\") COVER  
 WALLS AND BASE 2- 10M bar horizontal and vertical spaced evenly  
 LID @ 375mm O/C EW

WEIGHT: TANK BODY: 3770 KG (8,450 LBS)  
 LID: 1030 KG (2,300 LBS)  
 TOTAL: 4800 KG (10,750 LBS)

BURIAL DEPTH: 600mm (24\") MAXIMUM EARTH COVER - NON-VEHICULAR TRAFFIC

WATER TIGHTNESS: CON-SEAL CS-102 MASTIC SEALANT BETWEEN LID AND BOTTOM SECTION  
 APPLIED IN FACTORY ACCORDING TO MANUFACTURER'S RECOMMENDED METHOD

CENTRE WALL MONOLITHIC WITH TANK BODY

PIPE/WALL CONNECTIONS:

INLET - POLYLOK IV HIGH PRESSURE SEAL CAST IN CONCRETE FITTED WITH 100mm (4\")

OPEN-TOPPED TEE BAFFLE EXTENDING INTO LIQUID LEVEL 100mm (4\").

OUTLET - POLYLOK IV HIGH PRESSURE SEAL CAST IN CONCRETE FITTED WITH  
 TUF-TITE EF-6 EFFLUENT FILTER (1.6mm (1/16\") FILTRATION) EXTENDING INTO LIQUID  
 LEVEL 400mm (16\")

ACCESS OPENINGS: TUF-TITE 600mm $\varnothing$  ACCESS RISERS AND LID CAST IN CONCRETE. LID SECURED  
 WITH STAINLESS STEEL HARDWARE. LID EXTENDS 150mm ABOVE TOP OF TANK. ADDITIONAL  
 RISERS CAN BE ADDED TO BRING ACCESS TO GRADE.

TANK BODY AND LID LIFTED USING BOYD BROTHERS LTD SUPPLIED RIGGING

CONFORMS TO CSA STANDARD B66-10

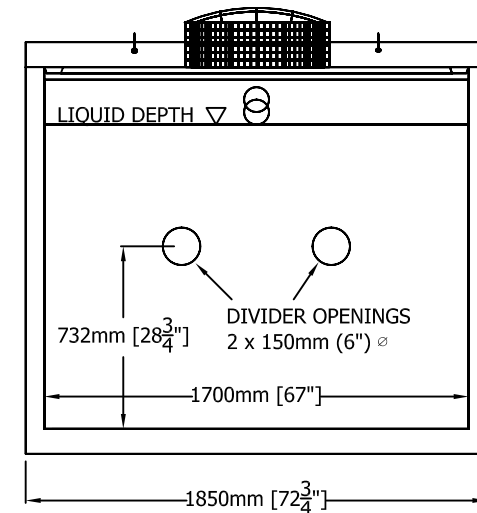
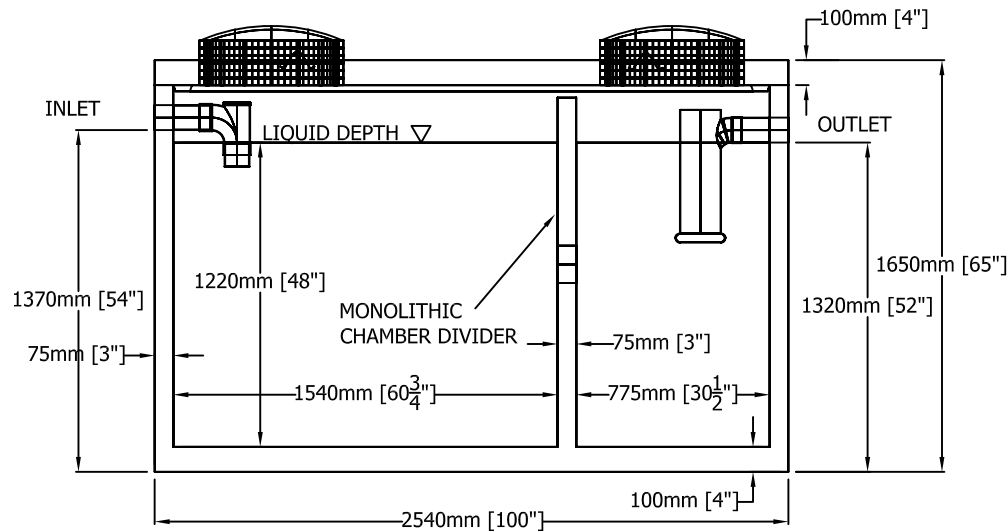

**BOYD BROTHERS**  
 5450 CUDDY ST, OSGOODE, ONT, K0A 2W0  
 tel (613) 826-2318 fax (613) 826-3679  
 toll free 888-846-6664  
 website www.boydbrosconcrete.ca  
 e-mail info@boydbrosconcrete.ca

PRODUCT		
4800L (1050 GAL) REGULAR SEPTIC TANK		
SERIES NO	MODEL NO	MODELS IN SERIES
4800	4800R	4800R, 3600L
SCALE	REV	DATE
1:30	1.0	MARCH 1, 2011

## Bulk-Filled Concrete Tank Diagram

Anaerobic Digester (AD), Pump Tank (PT) and Bulk-Filled Concrete Tank

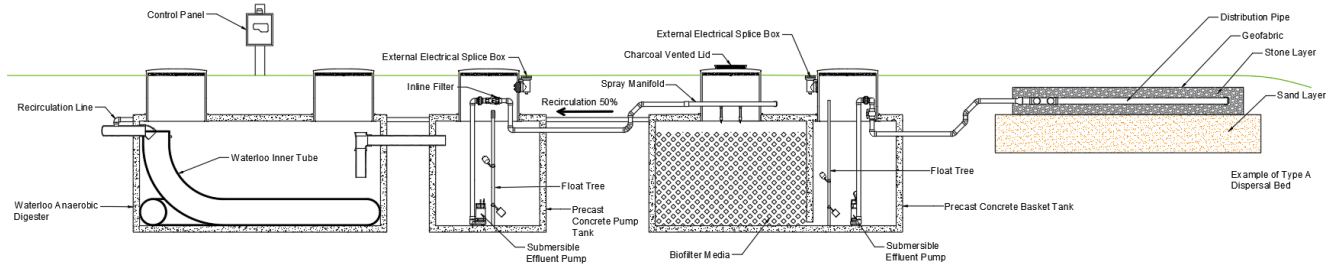

## Anaerobic Digester with Internal Pump Chamber (ADIPC) and Bulk-Filled Concrete Tank

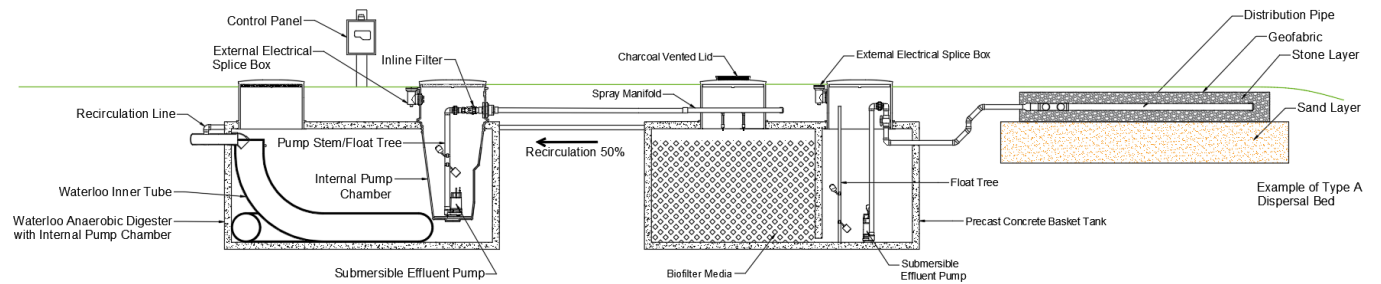

**From:** Ryan Good <[r.good@novatech-eng.com](mailto:r.good@novatech-eng.com)>  
**Sent:** Thursday, October 23, 2025 2:29 PM  
**To:** Tarundeep Gill <[tgill@waterloo-biofilter.com](mailto:tgill@waterloo-biofilter.com)>  
**Cc:** Lisa Bowley <[l.bowley@novatech-eng.com](mailto:l.bowley@novatech-eng.com)>; Anjush Musyaju <[a.musyaju@novatech-eng.com](mailto:a.musyaju@novatech-eng.com)>; Greg MacDonald <[g.Macdonald@novatech-eng.com](mailto:g.Macdonald@novatech-eng.com)>  
**Subject:** 541 Somme Street - Septic System Design - (124111)

Good morning Tarundeep,

Please note we are assisting a client with an industrial site plan development that requires a private, on-site septic system. We have specified Waterloo products in the past and I was hoping to propose one of your systems for this site.

My manager Lisa Bowley shared your contact information with me, and we were hoping you might be available next week to schedule a Teams call/meeting to review the project details. Can you please confirm if you have any availability and if so, please suggest a couple options (days/times) that work best for you?

I have attached a copy of our current Servicing Design drawing for your reference and the current Sanitary Design Flow based on our OBC calculation is 1005L/day. Let me know if you require any additional information at this time.

Thanks,

**Ryan Good**, C.E.T., Design Technologist | Land Development and Public Sector Infrastructure

## **NOVATECH**

Engineers, Planners & Landscape Architects

240 Michael Cowpland Drive, Suite 200, Ottawa, ON, K2M 1P6 | Tel: 613.254.9643 Ext: 284 | Cell: 343-364-2246

The information contained in this email message is confidential and is for exclusive use of the addressee.

**From:** Tarundeep Gill <[tgill@waterloo-biofilter.com](mailto:tgill@waterloo-biofilter.com)>

**Sent:** Friday, October 24, 2025 3:03 PM

**To:** Ryan Good <[r.good@novatech-eng.com](mailto:r.good@novatech-eng.com)>

**Cc:** Lisa Bowley <[l.bowley@novatech-eng.com](mailto:l.bowley@novatech-eng.com)>; Anjush Musyaju <[a.musyaju@novatech-eng.com](mailto:a.musyaju@novatech-eng.com)>; Greg MacDonald <[g.Macdonald@novatech-eng.com](mailto:g.Macdonald@novatech-eng.com)>; Emma Deyo <[edeyo@waterloo-biofilter.com](mailto:edeyo@waterloo-biofilter.com)>; Brady Straw <[Brady@waterloo-biofilter.com](mailto:Brady@waterloo-biofilter.com)>

**Subject:** Re: 541 Somme Street - Septic System Design - (124111)

Hello Ryan,

As per our records, Kyle was previously assigned to this project and, according to his notes, there are specific nitrogen removal requirements. Kindly confirm whether these requirements are still applicable. Additionally, we would appreciate it if you could provide details regarding the required percentage of nitrogen removal, as well as any associated monitoring or sampling requirements.

Regards,

Tarundeep Gill, MTech  
Wastewater Treatment System Designer



**Waterloo Biofilter Systems Inc.**

65 Massey Road, Suite C

Guelph, ON N1H 7M6

Office: 519-856-0757 x 205

Fax: 519-856-0759

[www.waterloo-biofilter.com](http://www.waterloo-biofilter.com)

***Is Yours a Waterloo?***

*Notice:*

This electronic transmission and any accompanying attachments are provided for convenience only and should be considered privileged and confidential. Waterloo Biofilter Systems Inc. assumes no liability or responsibility for the data supplied in this transmission, and the accuracy and completeness of data herein is the full responsibility of the user. Furthermore, the content in this electronic mail is only intended for the recipient(s) named above, and may not be copied, distributed, or disseminated. Please notify the sender immediately if you have received this message in error and delete the message and its contents from your computer.

**From:** Ryan Good <[r.good@novatech-eng.com](mailto:r.good@novatech-eng.com)>  
**Sent:** Friday, October 24, 2025 3:56 PM  
**To:** Tarundeep Gill <[tgill@waterloo-biofilter.com](mailto:tgill@waterloo-biofilter.com)>  
**Cc:** Lisa Bowley <[l.bowley@novatech-eng.com](mailto:l.bowley@novatech-eng.com)>; Anjush Musyaju <[a.musyaju@novatech-eng.com](mailto:a.musyaju@novatech-eng.com)>; Greg MacDonald <[g.Macdonald@novatech-eng.com](mailto:g.Macdonald@novatech-eng.com)>; Emma Deyo <[edeyo@waterloo-biofilter.com](mailto:edeyo@waterloo-biofilter.com)>; Brady Straw <[Brady@waterloo-biofilter.com](mailto:Brady@waterloo-biofilter.com)>  
**Subject:** RE: 541 Somme Street - Septic System Design - (124111)

Hi Tarundeep, thanks for returning my call. Please note the following based on your email below and the discussion we had:

### Nitrate Requirements

Paterson Group completed a Preliminary Nitrate Assessment for the site due to the Development being an Industrial project with a proposed private septic system. The results of that report suggested that the maximum allowable design flow for a Conventional Septic System would be 830L/day. The maximum allowable design flow for a Tertiary System (50% nitrate Reduction) would be 2500L/day. Our design flow is 1005L/day and therefore a tertiary System is required. Paterson's Nitrate Impact Assessment has been attached to this email for your reference.

The clip below is from the City of Ottawa Pre-consult where they indicate a Tertiary System may be considered if a Conventional System will not suffice.

- o. Since this application is a site plan (not lot creation or zoning) septic treatment (i.e. tertiary treatment with nitrate dilution) may be considered as part of the septic impact assessment calculations. A system certified though NSF or BNQ should be recommended.

### Monitoring Requirements

You also noted Kyle's records suggested requirements for maintenance and monitoring. Paterson's Nitrate Impact Assessment states "a Tertiary Septic System will require an annual maintenance contract" (see the first paragraph of Section 6.0). As discussed, I believe this is something Waterloo offers on a contractual basis. When the Waterloo design is developed, please include the maintenance contract details so we can include them in our Septic report and inform the Client (re. costs and what the program provides).

Let me know if you need anything further at this time.

**Ryan Good**, C.E.T., Design Technologist | Land Development and Public Sector Infrastructure

## **NOVATECH**

Engineers, Planners & Landscape Architects

240 Michael Cowpland Drive, Suite 200, Ottawa, ON, K2M 1P6 | Tel: 613.254.9643 Ext: 284 | Cell: 343-364-2246

The information contained in this email message is confidential and is for exclusive use of the addressee.

**From:** Tarundeep Gill <[tgill@waterloo-biofilter.com](mailto:tgill@waterloo-biofilter.com)>  
**Sent:** Tuesday, November 04, 2025 8:42 AM  
**To:** Ryan Good <[r.good@novatech-eng.com](mailto:r.good@novatech-eng.com)>; Lisa Bowley <[l.bowley@novatech-eng.com](mailto:l.bowley@novatech-eng.com)>  
**Cc:** Emma Deyo <[edevo@waterloo-biofilter.com](mailto:edevo@waterloo-biofilter.com)>  
**Subject:** Re: 541 Somme Street - Septic System Design - (124111)

Hello Ryan & Lisa,

It was a pleasure speaking with you both during our Teams meeting on October 29th.

As discussed, I am now working on the preliminary schematic design and reviewing our conversation to ensure everything is aligned before moving forward.

I have two quick questions regarding the floor drains:

- **Floor Drain Contents:** Could you confirm what typically goes into the floor drains? We'd like to know if this water can be sent to our treatment system, provided it is safe for the bacterial culture.
- **Flow Rate Inclusion:** The design flow rate is listed as 1,005 L/day. Does this include the floor drain flow, or that is required to be added separately?

Your clarification will help us finalize the system capacity and layout accurately.

Regards,

Tarundeep Gill, MTech  
Wastewater Treatment System Designer



**Waterloo Biofilter Systems Inc.**

65 Massey Road, Suite C  
Guelph, ON N1H 7M6  
Office: 519-856-0757 x 205  
Fax: 519-856-0759  
[www.waterloo-biofilter.com](http://www.waterloo-biofilter.com)

***Is Yours a Waterloo?***

*Notice:*

This electronic transmission and any accompanying attachments are provided for convenience only and should be considered privileged and confidential. Waterloo Biofilter Systems Inc. assumes no liability or responsibility for the data supplied in this transmission, and the accuracy and completeness of data herein is the full responsibility of the user. Furthermore, the content in this electronic mail is only intended for the recipient(s) named above, and may not be copied, distributed, or disseminated. Please notify the sender immediately if you have received this message in error and delete the message and its contents from your computer.

**From:** Ryan Good <[r.good@novatech-eng.com](mailto:r.good@novatech-eng.com)>  
**Sent:** Thursday, November 06, 2025 10:33 AM  
**To:** Tarundeep Gill <[tgill@waterloo-biofilter.com](mailto:tgill@waterloo-biofilter.com)>; Lisa Bowley <[l.bowley@novatech-eng.com](mailto:l.bowley@novatech-eng.com)>  
**Cc:** Emma Deyo <[edevo@waterloo-biofilter.com](mailto:edevo@waterloo-biofilter.com)>  
**Subject:** RE: 541 Somme Street - Septic System Design - (124111)

Hi Tarundeep,

The warehouse area is intended to store stormwater management items such as plastic geogrid, polymeric sand, and bulk drainage parts.

Also, there will be a forklift operating inside the warehouse at times; the water entering the drain is anticipated to be limited and the result of snow melt from the forklifts tires during the winter months. An oil grit separator will be proposed by the buildings mechanical consultant to capture any possible oil (presumably from the forklift in a rare accident/spill event) that may find its way into the drain.

Regarding the flow, the floor drain's flow is accounted for within the 1005L/day design flow.

Lisa please let Tarundeep know if you have anything to add to my response.

Thanks,

**Ryan Good**, C.E.T., Design Technologist | Land Development and Public Sector Infrastructure

**NOVATECH**

Engineers, Planners & Landscape Architects

240 Michael Cowpland Drive, Suite 200, Ottawa, ON, K2M 1P6 | Tel: 613.254.9643 Ext: 284 | Cell: 343-364-2246

The information contained in this email message is confidential and is for exclusive use of the addressee.

**From:** Tarundeep Gill <[tgill@waterloo-biofilter.com](mailto:tgill@waterloo-biofilter.com)>

**Sent:** Tuesday, November 11, 2025 8:41 AM

**To:** Ryan Good <[r.good@novatech-eng.com](mailto:r.good@novatech-eng.com)>

**Cc:** Lisa Bowley <[l.bowley@novatech-eng.com](mailto:l.bowley@novatech-eng.com)>; Emma Deyo <[edeyo@waterloo-biofilter.com](mailto:edeyo@waterloo-biofilter.com)>;  
Brady Straw <[Brady@waterloo-biofilter.com](mailto:Brady@waterloo-biofilter.com)>

**Subject:** Re: 541 Somme Street - Septic System Design - (124111)

Hello Ryan,

As discussed in the meeting, please find attached the preliminary schematic along with the tank drawings for this project.

Let me know if you need anything else.

Regards,

Tarundeep Gill, MTech  
Wastewater Treatment System Designer



**Waterloo Biofilter Systems Inc.**

65 Massey Road, Suite C

Guelph, ON N1H 7M6

Office: 519-856-0757 x 205

Fax: 519-856-0759

[www.waterloo-biofilter.com](http://www.waterloo-biofilter.com)

***Is Yours a Waterloo?***

*Notice:*

This electronic transmission and any accompanying attachments are provided for convenience only and should be considered privileged and confidential. Waterloo Biofilter Systems Inc. assumes no liability or responsibility for the data supplied in this transmission, and the accuracy and completeness of data herein is the full responsibility of the user. Furthermore, the content in this electronic mail is only intended for the recipient(s) named above, and may not be copied, distributed, or disseminated. Please notify the sender immediately if you have received this message in error and delete the message and its contents from your computer.

**From:** Ryan Good <[r.good@novatech-eng.com](mailto:r.good@novatech-eng.com)>  
**Sent:** Tuesday, November 18, 2025 12:57 PM  
**To:** Tarundeep Gill <[tgill@waterloo-biofilter.com](mailto:tgill@waterloo-biofilter.com)>  
**Cc:** Emma Deyo <[edeyo@waterloo-biofilter.com](mailto:edeyo@waterloo-biofilter.com)>; Brady Straw <[Brady@waterloo-biofilter.com](mailto:Brady@waterloo-biofilter.com)>; Lisa Bowley <[l.bowley@novatech-eng.com](mailto:l.bowley@novatech-eng.com)>; Anjush Musyaju <[a.musyaju@novatech-eng.com](mailto:a.musyaju@novatech-eng.com)>; Greg MacDonald <[g.Macdonald@novatech-eng.com](mailto:g.Macdonald@novatech-eng.com)>  
**Subject:** RE: 541 Somme Street - Septic System Design - (124111)

Hi Tarundeep,

I am hoping to clarify the details regarding the Floor Drain component of the buildings design (based on our Teams meeting and the emails below).

Can you please verify if the floor drain flows are acceptable to be directed into the Waterloo System or do we need to revise our layout to discharge the flow to the ditch?

Thanks,

**Ryan Good**, C.E.T., Design Technologist | Land Development and Public Sector Infrastructure

**NOVATECH**

Engineers, Planners & Landscape Architects

240 Michael Cowpland Drive, Suite 200, Ottawa, ON, K2M 1P6 | Tel: 613.254.9643 Ext: 284 | Cell: 343-364-2246

The information contained in this email message is confidential and is for exclusive use of the addressee.

**From:** Tarundeep Gill <tgill@waterloo-biofilter.com>

**Sent:** Tuesday, November 18, 2025 1:42 PM

**To:** Ryan Good <r.good@novatech-eng.com>

**Cc:** Emma Deyo <edeyo@waterloo-biofilter.com>; Brady Straw <Brady@waterloo-biofilter.com>; Lisa Bowley <l.bowley@novatech-eng.com>; Anjush Musyaju <a.musyaju@novatech-eng.com>; Greg MacDonald <g.Macdonald@novatech-eng.com>

**Subject:** Re: 541 Somme Street - Septic System Design - (124111)

Hello Ryan,

As discussed in our meeting, it is generally preferable that this type of water not enter the onsite sewage system. In similar cases, we have observed such water being directed to an oil/grit separator and subsequently discharged into dedicated infiltration trenches - essentially a Class 2 system

However, provided that the flows are properly accounted for—and as you noted in your email dated November 6th, the water entering the system will primarily result from snowmelt off forklift tires during the winter months—we do not anticipate any issues with this discharge into our system for this site.

Please ensure that appropriate care is taken regarding the substances allowed to enter these drains. Additionally, the oil/grit interceptor must be properly maintained.

**Regards,**

Tarundeep Gill, MTech

Wastewater Treatment System Designer



**Waterloo Biofilter Systems Inc.**

65 Massey Road, Suite C

Guelph, ON N1H 7M6

Office: 519-856-0757 x 205

Fax: 519-856-0759

[www.waterloo-biofilter.com](http://www.waterloo-biofilter.com)

***Is Yours a Waterloo?***

*Notice:*

This electronic transmission and any accompanying attachments are provided for convenience only and should be considered privileged and confidential. Waterloo Biofilter Systems Inc. assumes no liability or responsibility for the data supplied in this transmission, and the accuracy and completeness of data herein is the full responsibility of the user. Furthermore, the content in this electronic mail is only intended for the recipient(s) named above, and may not be copied, distributed, or disseminated. Please notify the sender immediately if you have received this message in error and delete the message and its contents from your computer.

**From:** Ryan Good <[r.good@novatech-eng.com](mailto:r.good@novatech-eng.com)>

**Sent:** Monday, March 16, 2026 10:31 AM

**To:** Tarundeep Gill <[tgill@waterloo-biofilter.com](mailto:tgill@waterloo-biofilter.com)>

**Cc:** Emma Deyo <[edevo@waterloo-biofilter.com](mailto:edevo@waterloo-biofilter.com)>; Brady Straw <[Brady@waterloo-biofilter.com](mailto:Brady@waterloo-biofilter.com)>; Lisa Bowley <[l.bowley@novatech-eng.com](mailto:l.bowley@novatech-eng.com)>; Greg MacDonald <[g.Macdonald@novatech-eng.com](mailto:g.Macdonald@novatech-eng.com)>; Anthony Mestwarp <[a.mestwarp@novatech-eng.com](mailto:a.mestwarp@novatech-eng.com)>

**Subject:** 541 Somme Street - Increased Demand - (124111)

Good morning Tarundeep,

We have revised our sanitary demand calculations for the development at 541 Somme Street based on changes to the Clients building design. The building has been updated to include one additional water closet in the warehouse and the addition changes our sanitary demand from 1100L/day to 1500L/day based on the OBC criteria.

Can you please confirm if there are any concerns with this increased demand in regard to the Waterloo system being proposed? The tanks are 4800L per our previous coordination.

Thanks,

**Ryan Good**, C.E.T., Design Technologist | Land Development and Public Sector Infrastructure

**NOVATECH**

Engineers, Planners & Landscape Architects

240 Michael Cowpland Drive, Suite 200, Ottawa, ON, K2M 1P6 | Tel: 613.254.9643 Ext: 284 | Cell: 343-364-2246

The information contained in this email message is confidential and is for exclusive use of the addressee.

**From:** Brady Straw <Brady@waterloo-biofilter.com>

**Sent:** Monday, March 16, 2026 1:56 PM

**To:** Ryan Good <r.good@novatech-eng.com>; Tarundeep Gill <tgill@waterloo-biofilter.com>

**Cc:** Emma Deyo <edeyo@waterloo-biofilter.com>; Lisa Bowley <l.bowley@novatech-eng.com>; Greg MacDonald <g.Macdonald@novatech-eng.com>; Anthony Mestwarp <a.mestwarp@novatech-eng.com>

**Subject:** Re: 541 Somme Street - Increased Demand - (124111)

Hi Ryan,

The ADIPC-4800 and BFCN-4800 are still the correct tanks for 1,500 L/day.

Regards,

Brady Straw, B.Sc.  
Head of Engineering



**Waterloo Biofilter Systems Inc.**

65 Massey Road, Suite C

Guelph ON N1H 7M6

Office: 519-856-0757 x180

Mobile: 519-546-6693

[www.waterloo-biofilter.com](http://www.waterloo-biofilter.com)

***Is Yours a Waterloo?***

---



## Appendix D

### Stormwater Management Information

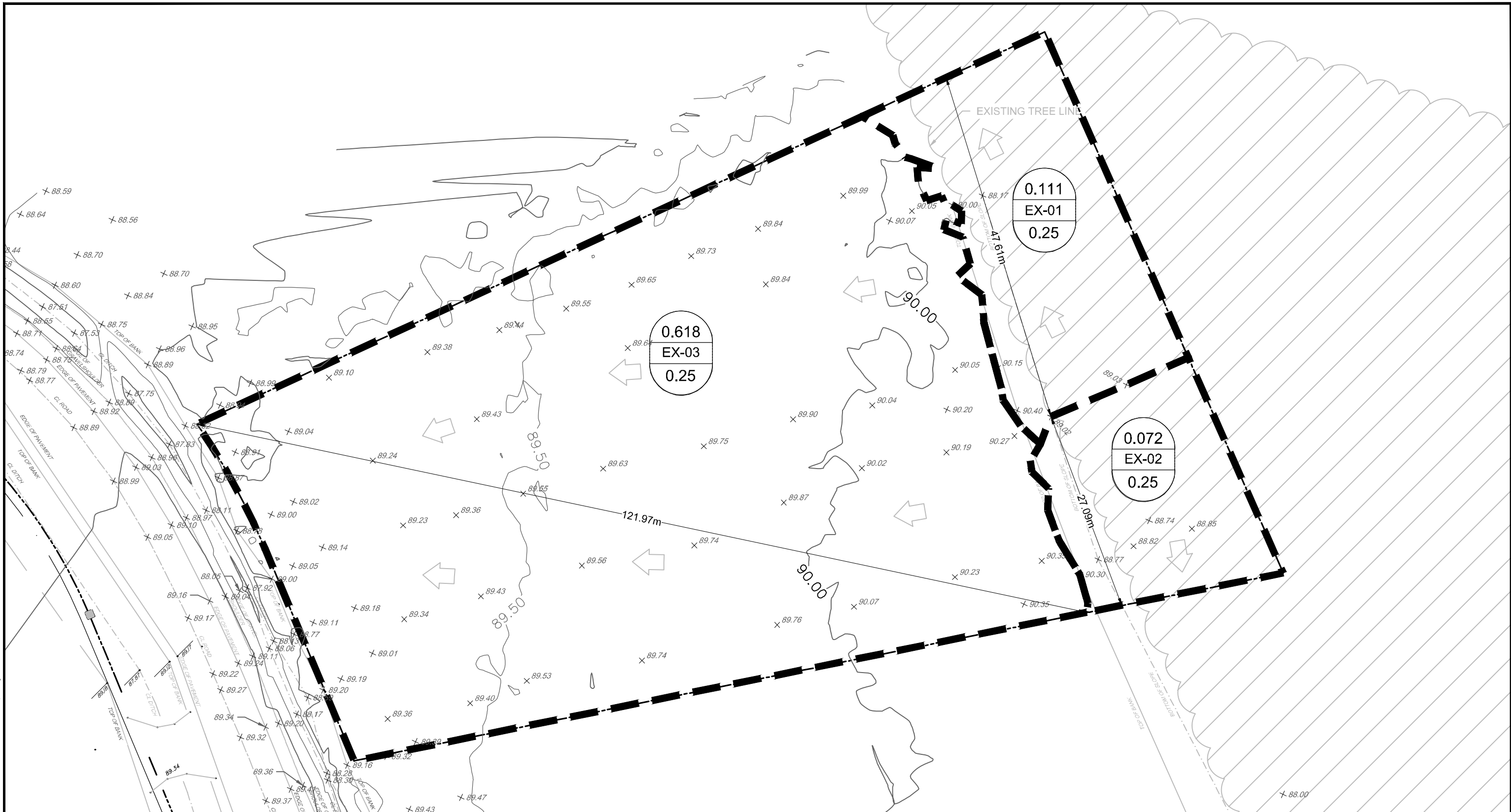
M:\2024\12411\CAD\Civil\12411-SWM-PRE.dwg, SWM Pre, Jan 28, 2025 - 10:53pm, rgood

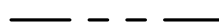

**LEGEND**

-  PROPOSED PROPERTY LINE
-  PROPOSED STORM DRAINAGE AREA

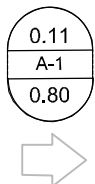

DRAINAGE AREA (HECTARES)  
DRAINAGE AREA ID

DIRECTION OF EXISTING MAJOR  
OVERLAND FLOW ROUTE



**NOVATECH**

Engineers, Planners & Landscape Architects  
Suite 200, 240 Michael Cowpland Drive  
Ottawa, Ontario, Canada K2M 1P6

Telephone (613) 254-9643  
Facsimile (613) 254-5867  
Website www.novatech-eng.com

**CITY OF OTTAWA**  
**541 SOMME STREET**

**SWM PLAN**  
**(PRE- DEVELOPMENT)**



SCALE 1 : 500 

DATE FEB, 2025 JOB 124111 FIGURE SWM-1

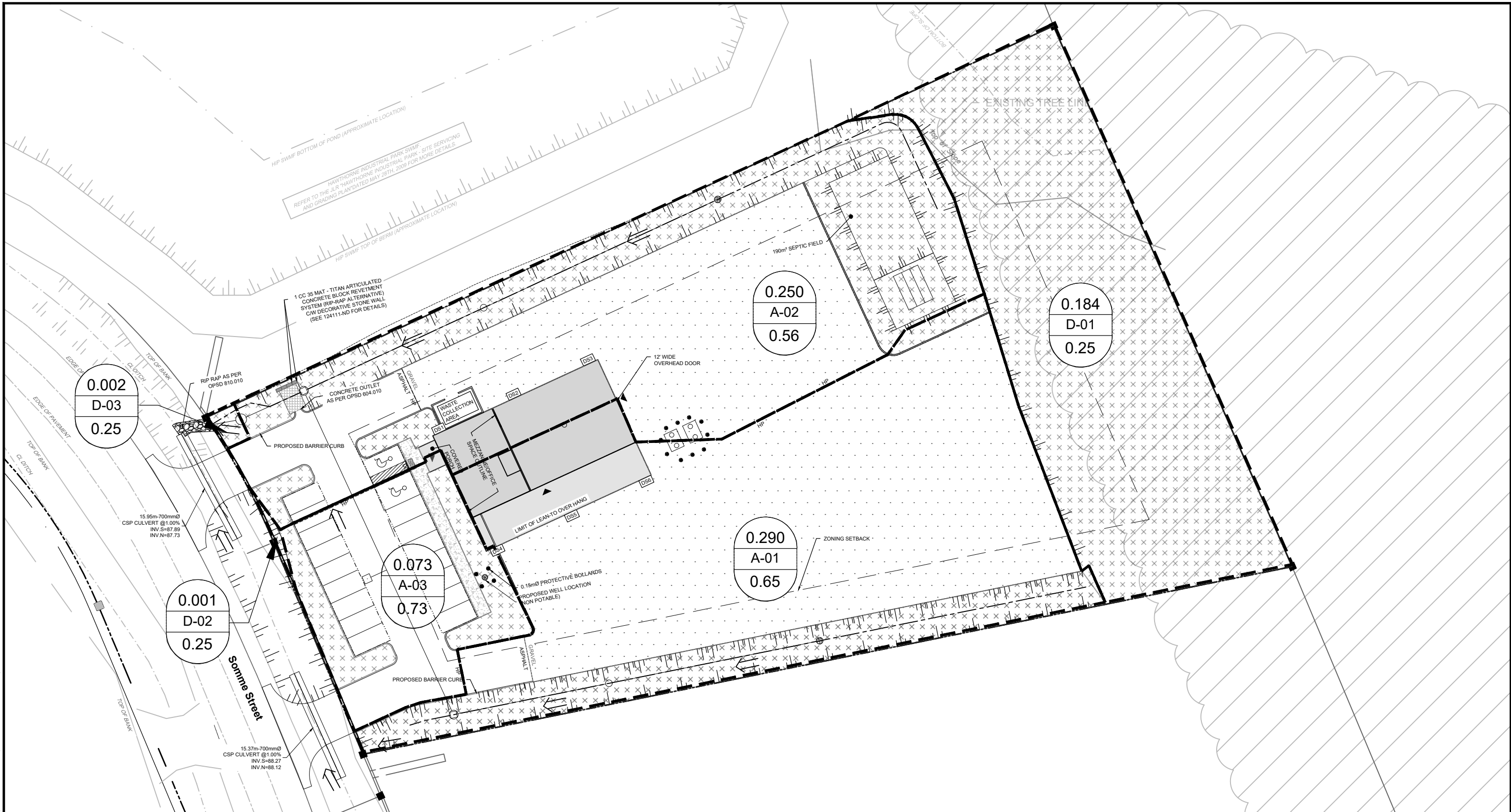
M:\2024\124111\CAD\Civil\124111-SWM-POST.dwg, Post SWM, May 04, 2026 - 1:19am, rgood



**LEGEND**

-  PROPOSED PROPERTY LINE
-  PROPOSED STORM DRAINAGE AREA

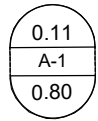

DRAINAGE AREA (HECTARES)  
DRAINAGE AREA ID



DIRECTION OF EXISTING MAJOR  
OVERLAND FLOW ROUTE



**NOVATECH**

Engineers, Planners & Landscape Architects  
Suite 200, 240 Michael Cowpland Drive  
Ottawa, Ontario, Canada K2M 1P6

Telephone (613) 254-9643  
Facsimile (613) 254-5867  
Website www.novatech-eng.com

**CITY OF OTTAWA**  
**541 SOMME STREET**

**SWM PLAN**  
**POST- DEVELOPMENT)**

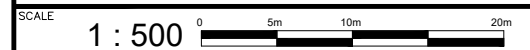

DATE	JOB	FIGURE
MAY 2026	124111	SWM-2

**TABLE 1A: Allowable Runoff Coefficient "C"**

Area	"C"
Total	0.25
0.801	

**TABLE 1B: Allowable Flows**

Outlet Options	Area (ha)	"C"	Tc (min)	Q <sub>2</sub> Year (L/s)	Q <sub>5</sub> Year (L/s)	Q <sub>100</sub> Year (L/s)
Hawthorne Industrial Park SWMF	0.801	0.70	10	119.8	162.5	278.5

Time of Concentration T<sub>c</sub>= 10 min  
 Intensity (2 Year Event) I<sub>2</sub>= 76.81 mm/hr  
 Intensity (5 Year Event) I<sub>5</sub>= 104.19 mm/hr  
 Intensity (100 Year Event) I<sub>100</sub>= 178.56 mm/hr

Equations:  
 Flow Equation  
 $Q = 2.78 \times C \times I \times A$

Where:  
 C is the runoff coefficient  
 I is the rainfall intensity, City of Ottawa IDF  
 A is the total drainage area

100 year Intensity =  $1735.688 / (\text{Time in min} + 6.014)^{0.820}$   
 5 year Intensity =  $998.071 / (\text{Time in min} + 6.053)^{0.814}$   
 2 year Intensity =  $732.951 / (\text{Time in min} + 6.199)^{0.810}$

### Time of Concentration - Existing Conditions

#### Uplands Overland Flow Method

TABLE 2A: Existing Conditions Time of Concentration

Area ID	Overland Flow						Overall Time of Concentration (min)
	Length (m)	Elevation U/S (m)	Elevation D/S (m)	Slope (%)	Velocity (m/s)	Travel Time (min)	
EX 01	47.61	89.02	87.10	4.0%	0.60	1.32	5
EX 02	27.09	89.02	88.77	0.9%	0.30	1.51	
EX 03	121.97	90.36	89.16	1.0%	0.34	5.98	

#### Uplands Velocity Chart

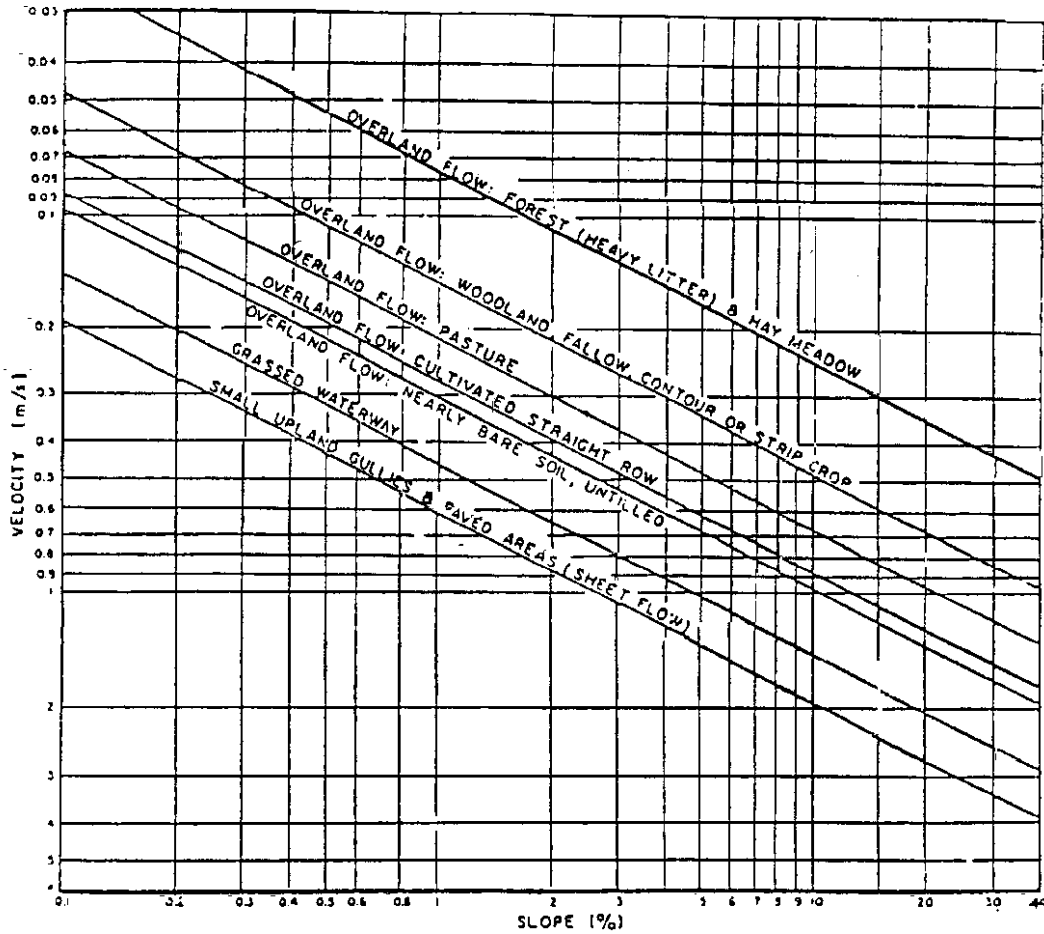

Figure A.5.2: Upland Method for Estimating Time of Concentration (SCS National Engineering Handbook, 1971)

**TABLE 3A: Post-Development Runoff Coefficient "C" - D-01**

Area	Surface	Ha	"C"	C <sub>avg</sub>	*C <sub>100</sub>	Runoff Coefficient Equation $C = (A_{hard} \times 0.9 + A_{soft} \times 0.2) / A_{Tot}$ * Runoff
Total	Hard	0.000	0.90	0.25	0.31	
0.182	Soft	0.181	0.25			

**TABLE 3B: Post-Development D-01 Flows**

Outlet Options	Area (ha)	C <sub>avg</sub>	Tc (min)	Q <sub>2 Year</sub> (L/s)	Q <sub>5 Year</sub> (L/s)	Q <sub>100 Year</sub> (L/s)
Ditch	0.182	0.25	10	9.7	13.1	28.1

Time of Concentration    Tc= 10    min  
 Intensity (2 Year Event)    I<sub>2</sub>= 76.81    mm/hr  
 Intensity (5 Year Event)    I<sub>5</sub>= 104.19    mm/hr  
 Intensity (100 Year Event)    I<sub>100</sub>= 178.56    mm/hr

Equations:  
 Flow Equation  
 $Q = 2.78 \times C \times I \times A$

Where:  
 C is the runoff coefficient  
 I is the rainfall intensity, City of Ottawa IDF  
 A is the total drainage area

100 year Intensity =  $1735.688 / (\text{Time in min} + 6.014)^{0.820}$   
 5 year Intensity =  $998.071 / (\text{Time in min} + 6.053)^{0.814}$   
 2 year Intensity =  $732.951 / (\text{Time in min} + 6.199)^{0.810}$

**TABLE 4A: Post-Development Runoff Coefficient "C" - D-02**

Area	Surface	Ha	"C"	C <sub>avg</sub>	*C <sub>100</sub>	Runoff Coefficient Equation $C = (A_{hard} \times 0.9 + A_{soft} \times 0.2) / A_{Tot}$ * Runoff
Total	Hard	0.000	0.90	0.25	0.31	
0.001	Soft	0.001	0.25			

**TABLE 4B: Post-Development D-02 Flows**

Outlet Options	Area (ha)	C <sub>avg</sub>	Tc (min)	Q <sub>2 Year</sub> (L/s)	Q <sub>5 Year</sub> (L/s)	Q <sub>100 Year</sub> (L/s)
Ditch	0.001	0.25	10	0.1	0.1	0.1

Time of Concentration Tc= 10 min  
 Intensity (2 Year Event) I<sub>2</sub>= 76.81 mm/hr  
 Intensity (5 Year Event) I<sub>5</sub>= 104.19 mm/hr  
 Intensity (100 Year Event) I<sub>100</sub>= 178.56 mm/hr

Equations:  
 Flow Equation  
 $Q = 2.78 \times C \times I \times A$

Where:  
 C is the runoff coefficient  
 I is the rainfall intensity, City of Ottawa IDF  
 A is the total drainage area

100 year Intensity =  $1735.688 / (\text{Time in min} + 6.014)^{0.820}$   
 5 year Intensity =  $998.071 / (\text{Time in min} + 6.053)^{0.814}$   
 2 year Intensity =  $732.951 / (\text{Time in min} + 6.199)^{0.810}$

**TABLE 5A: Post-Development Runoff Coefficient "C" - D-03**

Area	Surface	Ha	"C"	C <sub>avg</sub>	*C <sub>100</sub>	Runoff Coefficient Equation $C = (A_{hard} \times 0.9 + A_{soft} \times 0.2) / A_{Tot}$ * Runoff
Total	Hard	0.000	0.90	0.25	0.31	
0.002	Soft	0.002	0.25			

**TABLE 5B: Post-Development D-03 Flows**

Outlet Options	Area (ha)	C <sub>avg</sub>	Tc (min)	Q <sub>2 Year</sub> (L/s)	Q <sub>5 Year</sub> (L/s)	Q <sub>100 Year</sub> (L/s)
Ditch	0.002	0.25	10	0.1	0.1	0.3

Time of Concentration Tc= 10 min  
 Intensity (2 Year Event) I<sub>2</sub>= 76.81 mm/hr  
 Intensity (5 Year Event) I<sub>5</sub>= 104.19 mm/hr  
 Intensity (100 Year Event) I<sub>100</sub>= 178.56 mm/hr

Equations:  
 Flow Equation  
 $Q = 2.78 \times C \times I \times A$

Where:  
 C is the runoff coefficient  
 I is the rainfall intensity, City of Ottawa IDF  
 A is the total drainage area

100 year Intensity =  $1735.688 / (\text{Time in min} + 6.014)^{0.820}$   
 5 year Intensity =  $998.071 / (\text{Time in min} + 6.053)^{0.814}$   
 2 year Intensity =  $732.951 / (\text{Time in min} + 6.199)^{0.810}$

**TABLE 6A: Post-Development Runoff Coefficient "C" -A-01**

Area	Surface	Ha	"C"	C <sub>avg</sub>	*C <sub>100</sub>	Runoff Coefficient Equation $C = (A_{hard} \times 0.9 + A_{soft} \times 0.2) / A_{Tot}$ * Runoff
Total	Building	0.027	1.00	0.64	0.78	
0.290	Asphalt	0.006	0.90			
	Gravel	0.199	0.70			
	Grass	0.058	0.25			

**TABLE 6B: Post-Development A-01 Flows**

Outlet Options	Area (ha)	C <sub>avg</sub>	Tc (min)	Q <sub>2 Year</sub> (L/s)	Q <sub>5 Year</sub> (L/s)	Q <sub>100 Year</sub> (L/s)
Ditch	0.290	0.64	10	39.8	53.9	111.6

Time of Concentration Tc= 10 min  
 Intensity (2 Year Event) I<sub>2</sub>= 76.81 mm/hr  
 Intensity (5 Year Event) I<sub>5</sub>= 104.19 mm/hr  
 Intensity (100 Year Event) I<sub>100</sub>= 178.56 mm/hr

Equations:  
 Flow Equation  
 $Q = 2.78 \times C \times I \times A$

Where:  
 C is the runoff coefficient  
 I is the rainfall intensity, City of Ottawa IDF  
 A is the total drainage area

100 year Intensity =  $1735.688 / (\text{Time in min} + 6.014)^{0.820}$   
 5 year Intensity =  $998.071 / (\text{Time in min} + 6.053)^{0.814}$   
 2 year Intensity =  $732.951 / (\text{Time in min} + 6.199)^{0.810}$

**TABLE 7A: Post-Development Runoff Coefficient "C" -A-02**

Area	Surface	Ha	"C"	C <sub>avg</sub>	*C <sub>100</sub>	Runoff Coefficient Equation $C = (A_{hard} \times 0.9 + A_{soft} \times 0.2) / A_{Tot}$ * Runoff
Total	Building	0.015	1.00	0.57	0.68	
0.253	Asphalt	0.025	0.90			
	Gravel	0.120	0.70			
	Grass	0.093	0.25			

**TABLE 7B: Post-Development A-02 Flows**

Outlet Options	Area (ha)	C <sub>avg</sub>	Tc (min)	Q <sub>2 Year</sub> (L/s)	Q <sub>5 Year</sub> (L/s)	Q <sub>100 Year</sub> (L/s)
Ditch	0.253	0.57	10	31.0	42.0	85.3

Time of Concentration Tc= 10 min  
 Intensity (2 Year Event) I<sub>2</sub>= 76.81 mm/hr  
 Intensity (5 Year Event) I<sub>5</sub>= 104.19 mm/hr  
 Intensity (100 Year Event) I<sub>100</sub>= 178.56 mm/hr

Equations:  
 Flow Equation  
 $Q = 2.78 \times C \times I \times A$

Where:  
 C is the runoff coefficient  
 I is the rainfall intensity, City of Ottawa IDF  
 A is the total drainage area

100 year Intensity =  $1735.688 / (\text{Time in min} + 6.014)^{0.820}$   
 5 year Intensity =  $998.071 / (\text{Time in min} + 6.053)^{0.814}$   
 2 year Intensity =  $732.951 / (\text{Time in min} + 6.199)^{0.810}$

**TABLE 8A: Post-Development Runoff Coefficient "C" -A-03**

Area	Surface	Ha	"C"	C <sub>avg</sub>	*C <sub>100</sub>	Runoff Coefficient Equation $C = (A_{hard} \times 0.9 + A_{soft} \times 0.2) / A_{Tot}$ * Runoff
Total	Building	0.001	1.00	0.72	0.74	
0.073	Asphalt	0.052	0.90			
	Gravel	0.000	0.70			
	Grass	0.020	0.25			

**TABLE 8B: Post-Development A-03 Flows**

Outlet Options	Area (ha)	C <sub>avg</sub>	Tc (min)	Q <sub>2 Year</sub> (L/s)	Q <sub>5 Year</sub> (L/s)	Q <sub>100 Year</sub> (L/s)
Ditch	0.073	0.72	10	11.3	15.3	26.8

Time of Concentration Tc= 10 min  
 Intensity (2 Year Event) I<sub>2</sub>= 76.81 mm/hr  
 Intensity (5 Year Event) I<sub>5</sub>= 104.19 mm/hr  
 Intensity (100 Year Event) I<sub>100</sub>= 178.56 mm/hr

Equations:  
 Flow Equation  
 $Q = 2.78 \times C \times I \times A$

Where:  
 C is the runoff coefficient  
 I is the rainfall intensity, City of Ottawa IDF  
 A is the total drainage area

100 year Intensity =  $1735.688 / (\text{Time in min} + 6.014)^{0.820}$   
 5 year Intensity =  $998.071 / (\text{Time in min} + 6.053)^{0.814}$   
 2 year Intensity =  $732.951 / (\text{Time in min} + 6.199)^{0.810}$

**Table 9A: Post-Development Stormwater Management Summary**

Area ID	Area (ha)	1:2 / 1:5 Year Weighted Cw	1:100 Year Weighted Cw	Control Device	Outlet Location	2 Year Storm Event				5 Year Storm Event				100 Year Storm Event			
						Release (L/s)	Head (m)	Req'd Vol (cu.m)	Max. Vol. Provided (cu.m.)	Release (L/s)	Head (m)	Req'd Vol (cu.m)	Max. Vol. Provided (cu.m.)	Release (L/s)	Head (m)	Req'd Vol (cu.m)	Max. Vol. Provided (cu.m.)
D-01	0.182	0.25	0.31	N/A	Ditch	9.70	N/A	N/A	N/A	13.10	N/A	N/A	N/A	28.10	N/A	N/A	N/A
D-02	0.001	0.25	0.31	N/A	Ditch	0.10	N/A	N/A	N/A	0.10	N/A	N/A	N/A	0.10	N/A	N/A	N/A
D-03	0.002	0.25	0.31	N/A	Ditch	0.10	N/A	N/A	N/A	0.10	N/A	N/A	N/A	0.30	N/A	N/A	N/A
A-01	0.290	0.64	0.78	N/A	Ditch	39.80	N/A	N/A	N/A	53.90	N/A	N/A	N/A	111.60	N/A	N/A	N/A
A-02	0.253	0.57	0.68	N/A	Ditch	31.00	N/A	N/A	N/A	42.00	N/A	N/A	N/A	85.30	N/A	N/A	N/A
A-03	0.073	0.72	0.74	N/A	Ditch	11.30	N/A	N/A	N/A	15.30	N/A	N/A	N/A	26.80	N/A	N/A	N/A
<b>Post-Development Flow</b>						<b>92.0</b>				<b>124.5</b>				<b>252.2</b>			
<b>Total Allowable Release Rate</b>						<b>119.8</b>				<b>162.5</b>				<b>278.5</b>			

**Table 10A: Post-Development Weighted Runoff Coefficient**

Surface	Area (Ha)	C
Building	0.043	1.00
Asphalt	0.084	0.90
Gravel	0.320	0.70
Grass	0.355	0.25
Total	0.801	0.54

**WEIGHTED C VALUE CALCULATIONS:**

TOTAL SITE AREA = 0.801 HECTARES  
 BUILDING AREA = 0.043 HECTARES C = 1.00  
 ASPHALT AREA = 0.085 HECTARES C = 0.90  
 GRAVEL AREA = 0.320 HECTARES C = 0.70  
 GRASS AREA = 0.354 HECTARES C = 0.25  
 WEIGHTED RUNOFF COEFFICIENT (C) =  $((0.043*1)+(0.085*0.90)+(0.320*0.70)+(0.354*0.25))/0.801$   
 WEIGHTED RUNOFF COEFFICIENT (C) = 0.54

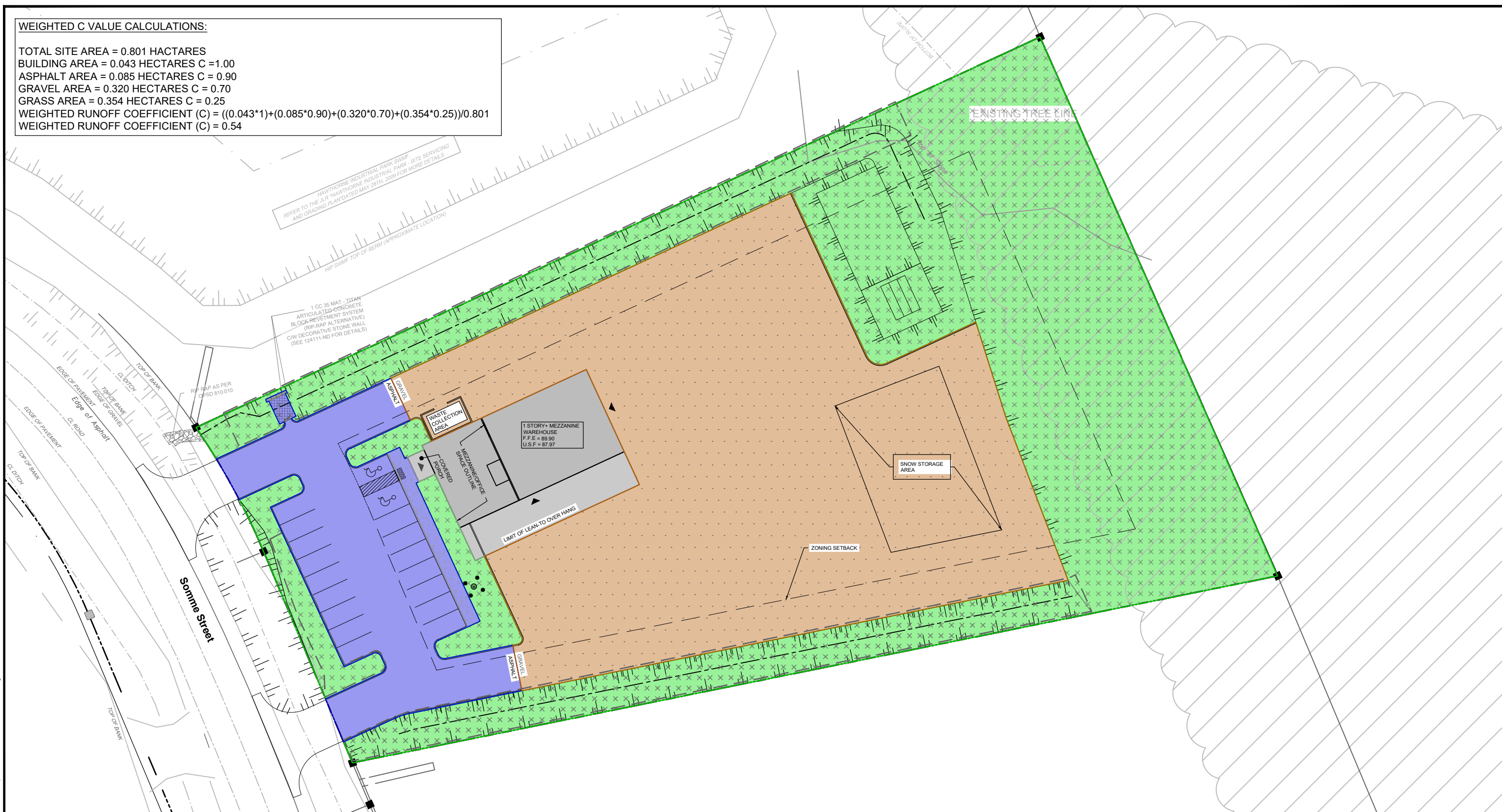

**LEGEND**

	BUILDING = 0.043 HECTARES		GRASS = 0.355 HECTARES
	ASPHALT = 0.084 HECTARES		
	GRAVEL = 0.320 HECTARES		



**NOVATECH**

Engineers, Planners & Landscape Architects  
 Suite 200, 240 Michael Cowpland Drive  
 Ottawa, Ontario, Canada K2M 1P6

Telephone (613) 254-9643  
 Facsimile (613) 254-5867  
 Website www.novatech-eng.com

**CITY OF OTTAWA**  
**541 SOMME STREET**

**SURFACE TYPES**

SCALE 1 : 500

DATE MAY 2026 JOB 124111 FIGURE SRF

EXCERPTS FROM "STORMWATER MANAGEMENT REPORT  
HAWTHORNE INDUSTRIAL PARK" JL RICHARDS  
(MAY 2009)

to provide aggregate wash water management to Tomlinson's existing quarry operations on the west side of Hawthorne Road (refer to Appendix 'I' for a copy of the Ministry of the Environment (MOE) Certificate of Approval (C of A) related to these works). In addition to the existing aggregate wash treatment facility, it is proposed to construct separate stormwater management facilities to service water quantity and quality requirements for the HIP.

### 1.3 Objectives

This Stormwater Management Report (SWMR) was prepared to demonstrate that the subject lands can be developed as an Industrial Park Subdivision in compliance with the current surface water objectives of the watershed. Since the subject lands drain to Findlay Creek, which is tributary to the North Castor River, storm runoff criteria for this development must be in accordance with the recommendations of the document entitled "Shield's Creek Subwatershed Study, Totten Sims Hubicki Associates, June, 2004", referred throughout this Report as SCSS. More specifically, the above Report provided the following design criteria with regard to stormwater:

#### Water Quantity

<u>Peak Flow</u>	Post-development peak flows must be controlled to pre-development levels for storm events ranging from a 1:2 year to a 1:100 year recurrence.
<u>Infiltration</u>	Section 5.5 of the SCSS recommends that the quantity and quality of groundwater infiltration be maintained to pre-development rates.
<u>Erosion</u>	The stormwater management strategy for the proposed HIP must be developed to maintain the erosion potential to current levels.

#### Water Quality

The proposed stormwater management strategy for HIP must be developed to meet a Normal Level of Protection (as per the MOE's publication entitled "Stormwater Management Planning and Design Manual, March, 2003", referred throughout this Report as SWMPDM, which corresponds to a standard approach used in urban development to obtain a targeted total suspended solids (TSS) removal rate of 70%.

## 2.0 STORM DRAINAGE

### 2.1 General

Storm servicing for the HIP was designed using the dual drainage concept, also known as the minor/major drainage system. The minor drainage system is mainly comprised of an on-site open ditch and culvert system. The minor system was designed to capture and convey runoff during frequent storm events up to a 1:10 year recurrence. The major system formed by swales/ditches, streets, etc. was sized to accommodate runoff during storm events exceeding 1:10 year up to the 1:100 year recurrence.

The open ditches, culverts and swales were sized using the Rational Method. An inlet time of 15 minutes and runoff coefficients (C-factors) ranging from 0.20 to 0.90 were used in the sizing of the conveyance systems. It should be noted, however, that C-factors used were increased by 10% for the 1:25 year peak flow calculations and by 25% for the 1:100 year recurrence, as per Section 5.4.5.2.1 of the City of Ottawa's Sewer Design Guidelines (November 2004). Rainfall intensities (i.e., Intensity-Duration-Frequency curves (IDF)) required by the Rational Method were also extracted from the City of Ottawa's Sewer Design Guidelines. Peak flow rates for the HIP and Hawthorne Road and Rideau Road are summarized in Table 1 (refer to Appendix 'A' for copies of the Rational Method Design Sheets for the 1:10 year and 1:100 year storm events).

**Table 1 - Summary of Peak Flow Rates**

Description	Peak Flows (L/s)	
	10 Year	100 Year
Hawthorne Industrial Park (HIP)	5,422	12,814
Hawthorne Road / Rideau Road	3,192	5,417

### 2.2 Design Criteria

The municipal infrastructure associated with the HIP was designed using the following criteria:

- The HIP open ditch system was sized with sufficient capacity to convey, under free-flowing conditions, the 1:100 year peak flow rate, as calculated by the Rational Method (refer to Appendix 'A' for a copy of the 1:100 year Design Sheet).
- The Hawthorne Road open ditch system was sized with sufficient capacity to convey, under free-flowing conditions, the 1:100 year peak flow rate, as calculated by the Rational Method (refer to Appendix 'A' for a copy of the 1:100 year Design Sheet).
- The existing downstream ditch system along Rideau Road was evaluated to ensure sufficient capacity to convey, under free-flowing conditions, the 1:100 year peak flow rate, as calculated by the Rational Method (refer to Appendix 'A' for a copy of the 1:100 year Design Sheet).
- The culverts included in the HIP and along Hawthorne Road/Rideau Road were sized with sufficient capacity to convey the 1:10 year peak flow rate without overtopping the roadway embankment (refer to Appendix 'A' for a copy of the 1:10 year Design Sheet).

- Given that the receiving watercourse was found to shelter fisheries, the SCSS recommended that a "normal" level of protection be achieved for quality control. To fulfill this requirement, industrial sites must direct runoff to an appropriately sized oil/grit separator unit before stormwater can be conveyed off site to the open roadside ditch/culvert system. To achieve quality control for the internal roads, it is proposed to provide infiltration storage volume in the roadside open ditch system, as per the requirements presented in Table 3.2 of the SWMPDM.
- The SCSS recommended that the erosion potential be maintained to current levels for the receiving water course. To fulfill the above requirement, the two year post-development peak flow will be controlled to 50% of the pre-development peak flow rate.

- Storage volume is to be implemented for the control of the post-development peak flows to pre-development levels for storm events ranging from a 1:2 year to a 1:100 year recurrence to comply with the recommendations of the SCSS.

This Stormwater Management Report (SWMR) has been written to demonstrate that the subject land could be developed in compliance with the above surface water criteria and also prepared in accordance with the SWMPDM. The proposed stormwater management strategy for the HIP was developed to meet a "normal" level of protection, which corresponds to a standard approach used in land development to obtain a targeted TSS removal rate of 70%.

### **3.0 STORM SERVICING**

#### **3.1 General**

Peak flow estimation is an important task that is carried out for any proposed development. There are several reasons that explain why flood flow rates are computed as part of site development. The main purpose of these calculations, however, is to allow for the proper configuration and sizing of the proposed conveyance systems to minimize the risk of flooding.

Drainage works are designed for a real or hypothetical storm event that may or may not happen during the lifetime of the facilities. At the onset of the design process, design criteria are adopted that may vary with the type of project, in recognition of the impacts of failure. For this particular project, the level of protection adopted (storm events up to a 1:100 year recurrence) was based on design storm characteristics of an infrequent storm event having a low probability to occur.

#### **3.2 Description of Conveyance Systems and Design Basis**

Flowing water can be conveyed to an outlet by either open-channel flow or pipe flow. Storm runoff generated by the subject lands is to be collected and conveyed by a roadside ditch/culvert system before discharging to Findlay Creek via an end-of-pipe stormwater management facility (SWMF).

Sizing of the conveyance systems was carried out using various levels of service. The open ditch system was sized with sufficient capacity to convey, under free-flowing conditions, storm runoff up to the 1:100 year recurrence, while roadway culverts were sized to provide conveyance of the 1:10 year peak flow rates without overtopping the roadway embankments.

As part of this sizing exercise, Storm Drainage Area Plans were prepared and included in this Report (refer to Drawing D-ST1 for the HIP and Drawing D-ST2 for Hawthorne and Rideau Road) that show the delineated area for each of the conveyance segments (i.e., from node location to node location), along with its assigned runoff coefficient (C-factor) based on the type of surface. Since the final development of Hawthorne Industrial Park is unknown at this time, a conservative on-site runoff coefficient (C-factor) of 0.70 was used. Table 2 illustrates the breakdown of a typical site that would generate a weighted runoff coefficient of 0.70.

**Table 2 - Typical Potential Land Use Breakdown**

Type of Surface	Area (%)	C-Factor
Building	10	1.0
Asphalt Parking	35	0.90
Gravel	35	0.70
Grass	20	0.20
Overall	100	<b>0.70</b>

It should be noted that the C-factors shown on the Storm Drainage Area Plans denote those associated with 1:10 year peak flow calculations. As recommended in Section 5.4.5.2.1 of the City of Ottawa's Sewer Design Guidelines, C-factors shown on drawings were increased by 10% and 25% for the 1:25 year and 1:100 year peak flow calculations, respectively (refer to Appendix 'A' for copies of the Rational Method Design Sheets).

### 3.2.1 Open Ditch System

An open ditch channel is a conduit used to convey flowing water from one location to another, with a free surface. A channel can be classified as either artificial (i.e., manmade) or natural. Artificial channels are those constructed or developed as a result of human activity. This type of conveyance system is usually implemented as a long and mild-sloped channel built in the ground, which provides conveyance of water between two points, with sections of regular geometry and shape. An open ditch system is generally designed to follow site topography and the vertical profile of the adjacent roadway. The most commonly used shapes for open channel ditches are trapezoidal and triangular, with the latter shape utilized mainly for ditches servicing small drainage areas.

The open ditches associated with the HIP and Hawthorne Road were sized with sufficient capacity to convey 1:100 year peak flow rates. As previously noted, the Rational Method Design Sheets (refer to Appendix 'A' for copy of the 1:100 year design sheet) were used to quantify the 1:100 year peak flow rates. The open ditch configuration was carried out utilizing Manning's relationship, along with the proposed geometry and slope of the channel. Two Storm Drainage Area Plans were prepared (refer to Drawings D-ST1 and D-ST2) showing proposed ditch inverts that match those shown on the Rational Method Design Sheets. Based on the ditch sizing exercise, it was determined that triangular shape ditches with 3:1 side slopes and variable depths provided the necessary conveyance of the 1:100 year peak flow rate. The Site Servicing and Grading Plan (refer to Drawing SG) was developed to provide the configuration of open ditch segments.

The existing open ditches along Rideau Road were also evaluated to ensure sufficient capacity was able to convey the 1:100 year peak flow rates resulting from upstream construction works (i.e., construction of Hawthorne Road). The Rational Method Design Sheets (refer to Appendix 'A' for copy of the 1:100 year design sheet) were used to quantify the 1:100 year peak flow rates. An existing 900 mm diameter culvert crossing under Hawthorne Road conveys flow along the north side of Rideau Road (refer to Drawing D-ST2). The capacity of this existing culvert was estimated at 1,400 L/s under a 1.5 m headwater (refer to Appendix 'B' for Culvert Design Summary Table). Upon the review of existing topography, any headwater depths greater than 1.5 m resulted in runoff being directed northerly along Hawthorne Road towards Findlay Creek. In light of the above, the existing open ditches along Rideau Road were evaluated using a conservative plug flow of 1,400 L/s in addition to surface runoff generated by the contributing areas.

### **3.2.2 Culvert System**

The principal function of a culvert is to convey water through an embankment while, at the same time, supporting the weight of the overlying fill and vehicular movement. Culverts can be made of many different materials; steel, polyvinylchloride (PVC), high density polyethylene (HDPE) and concrete. Culverts selected for the HIP and Hawthorne Road are made of corrugated steel, in either round or arch shape. Field observations have shown that there are two major types of culvert flow conditions: inlet control and outlet control.

### 1. Flow Under Inlet Control

Flow with inlet control means that the discharge capacity of a culvert is controlled at the culvert entrance by the depth of headwater and by the entrance geometry, including the barrel shape, cross sectional area and the type of inlet edge. The roughness and length of the culvert barrel, and the outlet conditions are not factors in determining the culvert capacity. The longitudinal slope reduces headwater only to a small degree and can normally be neglected for conventional culverts flowing in inlet control.

### 2. Flow Under Outlet Control

Flow with outlet control means that the discharge capacity of a culvert is controlled by the depth of tailwater, including the velocity head within the barrel, the entrance and friction losses. The roughness, length of the culvert barrel, and slope are factors in determining the culvert capacity; the inlet geometry is of lesser importance.

To avoid having to conduct detailed hydraulic computations that would determine the type of flow under which a culvert will probably operate, the procedure recommended by the MTO (refer to MTO's Drainage Management Manual) was utilized. This methodology, referred to as the Conventional Culvert Design procedure, requires that MTO's Design Charts and Design Nomographs be used for both inlet and outlet control conditions. The higher headwater depth that is calculated from those two operating conditions would indicate the type of control and would provide the governing headwater depth. This methodology was utilized to size each culvert crossing, along with the 1:10 year peak flow rates calculated by the Rational Method Design Sheets (refer to Appendix 'A') for each of the conveyance segments. Furthermore, this calculation sheet also provides proposed culvert sizes, along with the type of control and governing depth found when using the conventional culvert design procedure. A summary of the various parameters estimated using MTO's nomographs at each of the culverts has been tabulated using MTO's Form D4-1 (refer to Appendix 'B' for Conventional Culvert Design Sheet). This analysis shows that the proposed culvert crossings within the HIP and along Hawthorne Road are capable of conveying the 1:10 year peak flow rates as a minimum, without overtopping any of the roadway embankments. The hydraulic calculations were carried out assuming a roughness coefficient of 0.024 for any of the CSP and CSPA culverts. The Site Servicing and Grading Plan (Drawing SG) shows proposed culvert sizes, lengths and invert elevations at each of the crossings.

The proposed 1030 x 740 mm CSPA culvert crossing under the entrance of the pond access road was of concern due to the high flow rate during the 1:100 year storm event.

There was a possibility that the excess flow overtopping this culvert could short circuit into SWMF via the pond access road. Therefore, an analysis of the flow overtopping the proposed entrance culvert was conducted and the results confirmed that the residual flow would indeed be contained within the right-of-way corridor (refer to Appendix 'J' for desktop calculation).

#### 4.0 WATER BALANCE

Water balance analyses are typically carried out to assess any changes in infiltration to subsurface water-bearing zones as a result of the urbanization (i.e., increase of hard surfaces) of land. The SCSS has identified the need to maintain a necessary level of quantity and quality groundwater recharge via infiltration. Groundwater recharge is required to maintain subsurface base flow to streams and wetlands in addition to maintaining groundwater levels for private and municipal wells. The Hydrogeological Study completed by Golder Associates Limited in 2008 for the HIP identified the site as being underlain by a shallow and deep aquifer separated by an impermeable rock layer. The upper aquifer provided subsurface groundwater flow to streams, while the lower aquifer was the main source for well water supply. Therefore, groundwater recharge for this site was intended to provide subsurface base flow into the receiving Findlay Creek.

Construction fill operations have been active for the HIP since 1994. The results of the geotechnical field investigation conducted by Inspec-Sol Incorporated in 2008 indicates that as much as 5.5 m of fill material (MW7-08) has been placed on parts of the site. The non-native heterogenous fill material is comprised mainly of silty clay and contains trace amounts of road and construction materials. Although the soil component of the fill material exhibits the characteristics of silty clay, the varying composition and density of the remaining portion of the fill affects its permeability in localized areas. Given the above existing conditions, it is difficult to determine how groundwater recharge will behave as subsurface flow in the existing fill matrix, particularly from individual sites within the HIP. The MOE expressed concerns about the use of infiltration strategies on the individual sites given the past history as a construction fill site. Furthermore, the MOE SWMPDM does not endorse the use of infiltration basins on lands zoned for industrial use as there is an increased risk of groundwater contamination should a spill occur on site.

An option was considered to provide infiltration for the entire site at the base of the end-of-pipe Dry Pond facility. Upon further investigation, the geotechnical report indicated

that there was a high groundwater table at the proposed pond location. In addition, in-situ soils in the area exhibited poor drainage properties which would have resulted in long retention times at the base of the pond, making it difficult to meet the water balance deficit requirements for the entire site while attempting to mimic the pre-development hydrological cycle.

Representatives from the City and SNC were consulted, and it was concluded that the SCSS groundwater balance targets for this site would be difficult to meet. It was also recognized that on-site infiltration strategies for this industrial subdivision could have a detrimental effect on groundwater quality and jeopardize the natural ecological integrity of receiving waters. In light of the above, it was decided by the approval authorities that the requirement for the water balance would be waived for the HIP development.

## **5.0 WATER QUALITY**

### **5.1 General**

Urbanization has been found to modify the hydrological regime of a receiving stream if inadequate stormwater management measures are implemented. The potential impacts associated with runoff arise primarily from the amount of urban area that is impervious to rain and snowmelt water. These impervious surfaces increase the amount of direct surface runoff that is generated and is conveyed more efficiently to the receiving stream. As part of the SCSS, fisheries resources have been inventoried along this watercourse, along with its associated tributaries. Given that the receiving watercourses were found to shelter fisheries, the approved document recommended that a "normal" level of protection be achieved. To fulfil this requirement, it is proposed that each individual site provide an oil/grit separator and infiltration storage be provided within the roadside open ditch system, as per the requirements presented in the SWMPDM.

### **5.2 Water Quality Requirement**

Stormwater servicing for the HIP has been developed in accordance with the water quality recommendations of the SCSS (70% TSS removal). To fulfil this requirement, individual sites will be required to provide an oil/grit separator be installed to provide quality treatment (i.e., 70% TSS removal) of surface runoff before entering the roadside open ditch/culvert system. In addition, the oil/grit separator will be able to capture and contain hydrocarbons in the event of an on-site accidental spill.

To fulfill the water quality objectives for the paved portion of the HIP internal roads, it is proposed to provide infiltration within the open roadside ditch system to meet the storage volume requirements presented in Table 3.2 of the SWMPDM. Based on the normal level of service required and an imperviousness of 100% for the internal roads, Table 3.2 yields an extrapolated storage volume requirement of 35 m<sup>3</sup>/ha. To achieve this storage volume, a clear stone envelope complete with a 200 mm diameter perforated pipe will be installed at the base of the roadside ditches to meet the required storage volume (Refer to Appendix C for calculations).

The following table presents the calculated infiltration volume required for water quality control and those provided by the roadside open ditch system to meet the recommended MOE Design Guidelines.

**Table 3 - Water Quality Infiltration Requirements**

Phase	Area (ha)	Infiltration Volume Requirement (m <sup>3</sup> )	Infiltration Method	Length of 200 mm diameter Perf. Pipe (m)	Infiltration Volume Provided (m <sup>3</sup> )
1	1.58	55.1	Open Ditch	1760	55.3
2	0.21	7.4	Open Ditch	240	7.5
Total	1.79	62.5	Open Ditch	2000	62.8

As shown in the above Table, the infiltration volume provided by the proposed open roadside ditch network (62.8 m<sup>3</sup>) exceeds that obtained from Table 3.2 (62.5 m<sup>3</sup>) of the SWMPDM. It should be noted that additional storage within the void space of the clear stone envelope was not accounted for and would increase the actual infiltration storage volume shown in Table 3.

## 6.0 HYDROLOGICAL ANALYSIS

### 6.1 General

To satisfy the surface water objectives presented in Subsections 1.3 and 2.2, a hydrological analysis was carried out to quantify peak flow rate variations resulting from the development of the proposed HIP. To quantify this variation, the SWMHYMO Stormwater Management Hydrological Model (Version 4.02, July, 1999) was utilized to calculate peak flows during severe storm events.

To carry out the hydrological analysis, three storm drainage plans were developed; one representing the pre-development drainage conditions, one representing the post-development conditions for the current study area, Phase 1, and the other for the post-development drainage conditions, including future development, Phase 2. For each of these plans, subwatershed boundaries were delineated based on existing topography of the site and the proposed overland flow direction following development of the site (refer to Figures 2, 3 and 4 for details).

## **6.2 Synthetic Design Storm Simulation and Hydrological Parameters**

Peak runoff rates were calculated for both pre- and post-development conditions using synthetic design storm event modelling. Peak flow rates were estimated using the 3-hour Chicago Design Storm Event, as this synthetic storm event has been recognized as the most critical event for urban runoff applications (refer to Section 5.4.3.1 of the City of Ottawa's Sewer Design Guidelines). The design storm analysis was completed using volumes derived from the Intensity-Duration-Frequency (IDF) curve equation shown in Section 5.4.2 of the City of Ottawa Sewer Design Guidelines compiled using data from 1967 to 1997.

A SWMHYMO data file was developed to represent both pre- and post-development conditions of the subject area. Simulation of surficial runoff generated from undeveloped subwatersheds was carried out using the "DESIGN NASHYD" command along with the SCS procedure to compute rainfall losses. The SCS procedure uses the Curve Number (CN) method to compute rainfall losses and the Nash unit hydrograph to simulate the hydrological response from undeveloped watersheds. To simulate surface runoff from urban subwatersheds, the "CALIB STANDHYD" command was utilized. Hydrological parameter selection and methodology is described below:

### **Curve Number (CN)**

In order to estimate a Curve Number that represents pre-development conditions, the geotechnical investigation completed by Inspec-Sol, entitled "Geotechnical Study Subdivision Plan, Hawthorne Industrial Park, Lots 26 and 27 Concession 6, Southeast of Hawthorne and Rideau Roads, Ottawa, Ontario" dated December 19, 2008 was used. At the time of this investigation, large amounts of fill material were encountered over the majority of the site, which does not reflect the pre-development conditions. As such, only native soils encountered below fill material were used to establish pre-development condition Curve Numbers. The review of the geotechnical investigation shows native

FIGURE 3.dwg

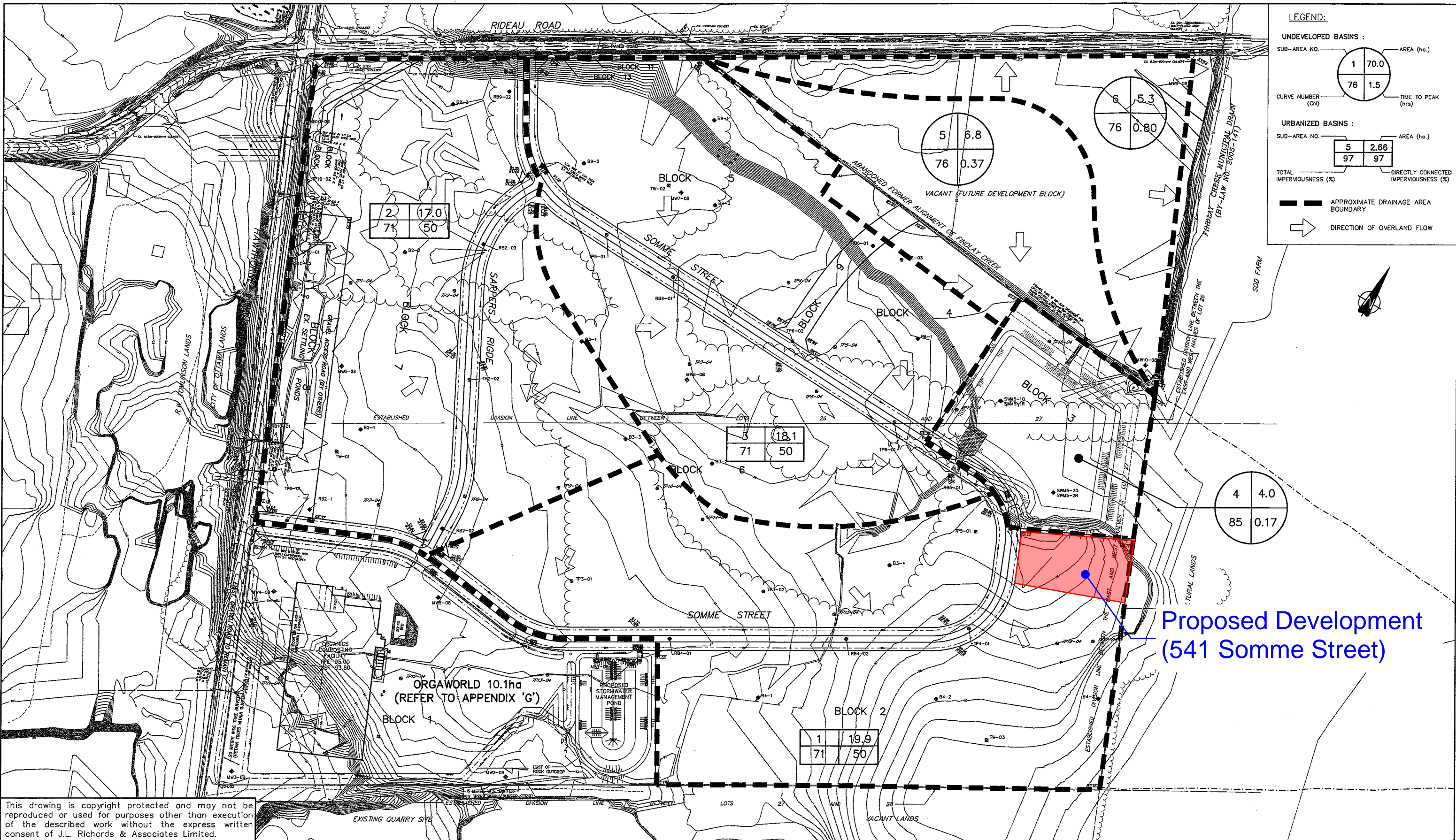

This drawing is copyright protected and may not be reproduced or used for purposes other than execution of the described work without the express written consent of J.L. Richards & Associates Limited.

PROJECT: **HAWTHORNE INDUSTRIAL PARK**

DRAWING: **POST DEVELOPMENT – PHASE 1 STORM DRAINAGE AREA PLAN**

**J.L. Richards & Associates Limited**  
 864 Lady Ellen Place  
 Ottawa, ON Canada  
 K1Z 5M2  
 Tel: 613 728 3571  
 Fax: 613 728 6012

DESIGN: M.B.  
 DRAWN: ARM  
 CHECKED: G.F.  
 PLOTTED: Apr 30, 2009

DRAWING NO.: **FIGURE 3**  
 JLR NO.: 20983

soils ranging from silty sand in Blocks 4 and 5, to silty clay in Blocks 3, 5, 7 and 8, to sandstone and limestone in parts of Blocks 2 and 3. These soils have been classified by Inspec-Sol as being associated with hydrologic soil groups (HSG), ranging from "B" to "D" for silty sand to silty clay, respectively. Areas where rock was encountered (i.e., Sandstone and Limestone) were classified as "Rockland." Based on this information and current land usage, as interpreted from aerial photography, a pre-development Curve Number (CN) of 76 has been calculated using the Ministry of Transportation of Ontario (MTO) Chart H2-8. Detailed calculations for the HIP have been included in Appendix 'D'.

Under post-development conditions, it is proposed to provide sufficient grade differential to allow for positive drainage to meet City of Ottawa Design Standards. As the subject lands are to be developed as an Industrial Park with a significant increase in hard surfaces (i.e., buildings, asphalt and gravel), the post-development conditions were, therefore, analysed taking into consideration the low potential of these surfaces to infiltrate storm runoff.

### **Imperviousness**

Surface runoff under post-development conditions is greatly impacted by the imperviousness of its tributary area. Since the final development of the HIP is unknown, a conservative assumption for typical surfaces encountered in similar industrial parks was developed, as illustrated in Table 2. To determine the imperviousness based on the assumed breakdown presented in Table 2, an imperviousness calculation was carried out and is presented in Appendix 'D'. The imperviousness calculation was based on the following assumptions:

- an imperviousness of 100% was assigned for building footprints;
- an imperviousness of 100% was assigned for all asphalt parking surfaces.
- an imperviousness of 70% was assigned for all gravel surfaces; and
- it was assumed that 50% of the total imperviousness (TIMP) 50 % was modelled as directly connected imperviousness (XIMP).

Based on the above, a total imperviousness of 70% was calculated, which is equivalent to a runoff coefficient of 0.7. The hydrological analysis was, therefore, carried out using

a total imperviousness of 70%, consistent with the runoff coefficient used for sizing the open ditch/culvert system.

### **Time to Peak ( $T_p$ )**

Time to peak calculations were carried out under pre-development conditions. Time of concentration was first estimated using the Uplands Method Chart based on the various flow paths. Once calculated, the times to peak were set to 67% (i.e., 2/3) of the time of concentration ( $T_c$ ). Under pre-development conditions, a 90 minute time to peak was calculated (refer to Appendix 'D' for calculations). When modelling post-development conditions, the "CALIB STANDHYD" command was used to calculate the time to peak associated with the proposed site surfaces and grades (refer to Appendix 'E' for SWMHYMO outputs).

### **6.3 Simulation of Pre- and Post-Development (Uncontrolled) Conditions**

The hydrological analysis was carried over the entire HIP under both the pre- and post-development conditions. As stated in Section 6.1, two post-development conditions were investigated, namely, Phase 1 and Phase 2. Phase 1 evaluates servicing for the current Study area, while Phase 2 includes the current Study area along with servicing of an additional 11.2 ha of land to the north east, shown on drawings as "Future Development Block."

Peak flow rates were computed with SWMHYMO using the procedure and parameters described in Subsection 6.2. Table 4 presents the simulated peak runoff rates under a 3 hour Chicago design storm event for both the pre- and post- (uncontrolled) development conditions for the HIP (refer to Appendix 'E' for SWMHYMO data input and output files), along with those under a 4 hour - 25 mm storm.

**Table 4 - SWMHYMO Simulation Results**

Return Period or Storm Depth	Peak Flow Rates (L/s)		
	Pre-Development	Phase 1 Post-Development (Uncontrolled)	Phase 2 Post-Development (Uncontrolled)
25 mm	252	1,941	2,231
2	467	3,077	3,548
5	826	4,812	5,554
10	1,097	6,135	7,029
25	1,468	7,772	9,013
50	1,767	9,240	10,588
100	2,093	10,662	12,132

Simulation results presented in the above table show that uncontrolled post-development peak flows substantially exceed those obtained under pre-development conditions. Based on the design criterion for water quantity (refer to Subsections 1.3 and 2.2 for details), post-development peak flows should be maintained to their pre-development levels for storm events ranging from a 1:5 year to a 1:100 year recurrence. In addition, the 2-year post-development peak flow should be controlled to 50% of the 2-year pre-development peak flow to satisfy the erosion criterion. Water quantity control measures were, therefore, found to be necessary for the development of this site. Details and stormwater servicing approaches proposed to fulfil the design criteria listed in Subsections 1.3 and 2.2 are presented in the following Subsections.

#### **6.4 Simulation of Phase 1 Post-Development (Controlled) Conditions**

Development of the subject lands (i.e., 70 ha, as illustrated on Figure 3) will increase the imperviousness of the subject area. To achieve the surface water objectives listed in Subsections 1.3 and 2.2, it is proposed that an end-of-pipe facility be constructed that would provide storage volume for retention of runoff.

The stormwater management criteria for the development of the HIP consist of maintaining erosion potential and peak flow rates at the pre-development levels. Storm servicing of the Subdivision was, therefore, developed such that all of these requirements were fulfilled, along with the achievement of a "normal" protection level. It

is proposed to implement the following stormwater management servicing approach for the development of the HIP:

### **End-of-Pipe SWMF (Block 3)**

Based on the proposed grading, the end-of-pipe facility was found to generate a volume of 37,240 m<sup>3</sup> (3.25 m depth). A low flow ditch sized for 2 year storm events was also included in the bottom of the end-of-pipe facility to convey flows to the outlet structure. The configuration of the outlet structure would be as follows:

- 1 x 150 mm diameter orifice within a 200 mm diameter Polyvinyl Chloride (PVC) pipe at elevation 82.90 m, which serves as outlet to the facility;
- 2 x 600 mm diameter Corrugated Steel Pipe culvert at elevation 84.80 m, which also serves as outlet to the facility;
- One (1) emergency overflow spillway (6.0 m wide) at elevation 86.15 m, which serves as outlet to the facility during a storm event greater than 1:100 year.

The above configuration was used to develop a Stage-Storage-Discharge relationship that relates the storativity and outlet capabilities of the proposed facility at various geodetic elevations (refer to Appendix 'F' for copy of this Table). This data (storage-discharge table) was then used as input to the SWMHYMO's ROUTE RESERVOIR command.

A SWMHYMO file, representing the post-development controlled conditions of the HIP, was developed incorporating the storage volume and the outflow capability of the proposed end-of-pipe facility. The following table presents the simulated peak runoff rates for the three (3) hour Chicago design storm under the post-development controlled conditions (refer to Appendix 'G' for SWMHYMO data input and output files), along with those under the four (4) hour - 25 mm storm.

**Table 5 - SWMHYMO Simulation Results  
(Post-Development - Phase 1 Controlled Conditions)**

Return Period or Storm Depth	Peak Flow Rates (L/s)	
	Pre-Development	Phase 1 Post-Development (Controlled) <sup>(1)</sup>
25 mm	252	127
2 year	467	194 <sup>(2)</sup>
5 year	826	359
10 year	1,097	589
25 year	1,468	939
50 year	1,767	1,191
100 year	2,093	1,531

Note: (1) Post-development flow is the sum of flows from the end-of-pipe facility and two uncontrolled Sub-Areas totalling 12.1 ha.

(2) 2 year post-development peak flow less than half the 2-year pre-development peak flow (233 L/s).

Simulation results presented in Table 5 show that the Phase 1 post-development controlled peak flows will be maintained below pre-development levels for the HIP. Consequently, the water quantity objective defined in Subsections 1.3 and 2.2 will be met under Phase 1.

### 6.5 Simulation of Phase 2 Post-Development (Controlled) Conditions

Development of Phase 2, as depicted on Figure 4, includes the Future Development Block located in the northeast corner of the HIP. This additional land could be serviced by the previously proposed end-of-pipe facility, without any modifications to facility size or outlet structure. However, a second inlet would be required in the northeast corner of the facility, which could be designed during the detailed design stage of the Future Development Block.

A SWMHYMO file, representing the Phase 2 post-development controlled conditions of the HIP, was developed incorporating the storage volume and the outflow capability of the proposed end-of-pipe facility. The following table presents the simulated peak runoff rates for the three (3) hour Chicago design storm under the Phase 2 post-development

controlled conditions (refer to Appendix 'H' for SWMHYMO data input and output files), along with those under the four (4) hour - 25 mm storm.

**Table 6 - SWMHYMO Simulation Results  
(Post-Development - Phase 2 Controlled Conditions)**

Return Period or Storm Depth	Peak Flow Rates (L/s)	
	Pre-Development	Phase 2 Post-Development (Controlled) <sup>(1)</sup>
25 mm	252	73
2 year	467	156 <sup>(2)</sup>
5 year	826	457
10 year	1,097	729
25 year	1,468	1,051
50 year	1,767	1,348
100 year	2,093	1,515

Note: (1) Post-development flow is the sum of flows from the end-of-pipe facility and one uncontrolled Sub-Area totalling 2.7 ha.

(2) 2-year post-development peak flow less than half the 2 year pre-development peak flow (233 L/s).

Simulation results presented in Table 6 show that the Phase 2 post-development controlled peak flows will be maintained below pre-development levels for the HIP. Consequently, the water quantity objective defined in Subsections 1.3 and 2.2 will also be met under Phase 2.

## 6.6 Simulation of the July 1, 1979 Historical Storm Event and Flood Potential

### 6.6.1 Simulation of the July 1, 1979 Historical Storm Event

In addition to designing the major drainage system to convey the 1:100 year storm event, the performance of both the open ditch system and SWMF was also assessed under the July 1, 1979 historical storm event. This historical storm event is defined as a high volume / low intensity storm event (when compared to the 1:100 year event) which

occurred mostly over a three hour period (refer to Table 5.6 in the Ottawa Sewer Design Guidelines). As shown in Table 5.6, the maximum intensity of 106.7 mm/hr only occurred for a 10 minute period (i.e., between the 85 to 95 minute time interval). The 1:100 year storm event intensities used to size the open ditch system were found to exceed the highest intensity of 106.7 mm/hr (refer to Appendix 'A' for 1:100 year Rational Method Sheet) with the exception of the most downstream ditch section (i.e., from Node 19 to Pond) where an intensity of 101.69 mm/hr was rather utilized. If an intensity of 106.7 mm/hr was used, the overall peak flow would increase from 12,814 L/s to 13,430 L/s substantially less than the free-flowing capacity of 52,735 L/s for the proposed ditch configuration. Consequently, the proposed open ditch system has the ability to convey flows generated by the July 1, 1979 storm event.

To supplement the above open ditch analysis, a hydrological analysis was also conducted to assess the performance of the SWMF under the July 1, 1979 storm event. A SWMHYMO file was, therefore, developed for the controlled Phase 2 post-development conditions of the HIP. Simulation results show that the Phase 2 post-development runoff during the July 1, 1979 storm event will be contained within the SWMF with all three of the outlet culverts flowing full in addition to approximately 210 mm of flow depth over the emergency overflow channel (refer to Appendix 'K' for SWMHYMO data input and output files). Therefore, the outlet of the SWMF has sufficient capacity to convey the July 1, 1979 historical storm event via the designated overland flow route without overtopping the banks.

### 6.6.2 Flood Potential

Draft approval Condition 12 of the draft subdivision conditions by the former Region of Ottawa-Carleton requires that "The owner shall complete a study indicating the extent of potential flooding on the property from Findlay Creek. The study including all models and assumptions shall be to the satisfaction of the South Nation River Conservation Authority." This condition was included as part of the original February 10, 1998 draft conditions (Gloucester File: S-RU-94-03).

Many changes have occurred on-site and adjacent to the site since Condition 12 was included in the draft approval for this site. Improvements to the roadside ditch were made along Rideau Road, immediately adjacent to the site. Surface runoff generated by the lands north of Rideau Road and conveyed to the small tributary located within the HIP site has now been re-directed toward the northeast corner of the site where the existing 3.8 m wide x 2.8 m high multi plate arch culvert crosses Rideau Road. A

municipal drainage report was prepared by Stantec Consulting in 2004 for this section of Findlay Creek which assessed the overall geomorphological conditions and provided recommendations for future maintenance. In addition, the SCSS conducted a flood hazard analysis. The 100 year flows from the Stantec model were plotted along the creeks modelled. Floodlines were shown in Figure 6.2.3 of the report. No floodlines were indicated for the section of Findlay Creek adjacent to the HIP site.

As indicated previously in the Section 4 of this Report, as much as 5.5 m of construction fill has been added to the site since 1994. The placed fill material on the site has eliminated the natural low lying areas and raised the site grade approximately 4.5 m above the top of creek bank. The current site grades will be maintained as a minimum for the development of the HIP subdivision. Therefore, we have no concerns about flooding on the property from Findlay Creek given the above changes to the site and improvements to the adjacent drainage network. Consequently, Condition 12 of the draft approval should be considered as being satisfied on the basis that this condition is out of date based on the current site conditions.

## **7.0 EROSION AND SEDIMENT CONTROL MEASURES DURING CONSTRUCTION**

During construction of the roadway, the collection systems (i.e., ditches, culverts, sewers, etc.) and end-of-pipe facility, appropriate erosion and sediment control measures, as outlined in MNR's "Guidelines on Erosion and Sediment Control for Urban Construction Sites," will be implemented to trap sediment on site. To ensure proper implementation, the proposed measures have been incorporated onto Drawing ESC (Drawing entitled "Erosion and Sedimentation Control Plan"). The measures shown on this Drawing were developed based on topography and site constraints. As a minimum, the following measures will be implemented during construction:

- Supply and installation of straw bale flow check dams (as per OPSD 219.180) at the upstream end of each culvert. Proposed locations of straw bale barriers are indicated on Drawing ESC.
- Supply and installation of topsoil and hydroseed along the entire open ditch system once grading has been completed for a section. Mulching will be carried out immediately after hydroseeding. This will allow for immediate bank stabilization of the system and will prevent sediment laden from occurring from exposed ditch surfaces.

- Supply and installation of light duty silt fences (as per OPSD 219.110) at the toe of slope surrounding the proposed stormwater management pond (refer to Drawing ESC for details). It is recommended that silt fences also be used to enclose borrow and stockpile areas resulting from topsoil stripping activities or any excavating activities; locations to be determined in the field during grading operations.
- If dewatering and pumping operations become necessary, filtration is proposed using sediment dewatering bags prior to discharge off-site.

All control measures will be carried out in accordance with the following documents:

- i) "Guidelines on Erosion and Sediment Control for Urban Construction Sites" published by Ontario Ministries of Natural Resources, Environment, Municipal Affairs and Housing, and Transportation and Communication, Association of Construction Authorities of Ontario, and Urban Development Institute, Ontario, May 1987.
- ii) "Erosion and Sediment Control" Training Manual by Ministry of Environment, Spring 1998.
- iii) Applicable Regulations and Guidelines of the Ministry of Natural Resources. As a minimum, during the construction of the conveyance systems, the following Stormwater Management Practices will be used:

Any stockpiled material will be kept on flat areas during construction, well away from any natural flow paths. In the event that the stockpile is placed in other areas where potential washoff to the conveyance system is expected, silt fences will be installed to enclose the materials and prevent any washoff to the conveyance system.

## 8.0 SUMMARY AND CONCLUSION

1. This Stormwater Management Report has been prepared to present a complete approach in achieving the stormwater criteria developed as part of the approved document entitled "Shields Creek Subwatershed Study."
2. Stormwater servicing for the proposed HIP has been designed using the dual drainage concept. Storm servicing will be carried out with the use of an open ditch/culvert system. The open ditch system has been designed to convey the 1:00 year peak flow rates. Similarly, the culverts have been sized to convey the 1:10 year flow without any overtopping.
3. To fulfil the design criteria associated with water quality (as per the SCSS), it is proposed to provide both on-site oil/grit separators and infiltration storage volume within the roadside open ditch system. As per the requirements set out in Table 3.2 of the MOE SWMPDM, a total infiltration volume of 62.5 m<sup>3</sup> is required under Phase 2 to achieve a "normal" level of protection (i.e., TSS removal of 70%).
4. Water balance and infiltration requirements were not implemented due to existing site conditions and proposed industrial use development.
5. The 2-year post-development peak flow will be controlled to 50% of the 2-year pre-development peak flow. Therefore, meeting the SCSS recommendations associated with erosion potential.
6. Simulation results presented in Tables 5 and 6 show that proposed infrastructure will maintain peak flows below pre-development levels for both Phase 1 and Phase 2 of the HIP. Consequently, this design criterion (peak flow control) will be fulfilled.
7. A detailed Erosion and Sedimentation Control Plan has been prepared to reduce the impact of construction activities on Findlay Creek.

Rinker Materials  
EFO4 Stormceptor and ETV Documents



Stormceptor®EF Sizing Report

<b>Imbrium® Systems</b>		<b>ESTIMATED NET ANNUAL SEDIMENT (TSS) LOAD REDUCTION</b>		08/19/2025																
Province:	Ontario	Project Name:	541 Somme St.																	
City:	Ottawa	Project Number:	124111																	
Nearest Rainfall Station:	OTTAWA CDA RCS	Designer Name:	Brandon O'Leary																	
Climate Station Id:	6105978	Designer Company:	Rinker Pipe																	
Years of Rainfall Data:	20	Designer Email:	brandon.oleary@RinkerPipe.com																	
Site Name:	541 Somme St.	Designer Phone:	905-630-0359																	
Drainage Area (ha):	0.618	EOR Name:	Ryan Good																	
Runoff Coefficient 'c':	0.62	EOR Company:	Novatech Engineering Consultants Ltd.																	
Particle Size Distribution:	Fine	EOR Email:																		
Target TSS Removal (%):	80.0	EOR Phone:																		
Required Water Quality Runoff Volume Capture (%):	90.0																			
Oil / Fuel Spill Risk Site?	Yes	<table border="1" style="width: 100%; border-collapse: collapse;"> <thead> <tr> <th colspan="2" style="text-align: center;"><b>Net Annual Sediment (TSS) Load Reduction Sizing Summary</b></th> </tr> <tr> <th style="width: 50%;">Stormceptor Model</th> <th style="width: 50%;">TSS Removal Provided (%)</th> </tr> </thead> <tbody> <tr> <td style="text-align: center;">EFO4</td> <td style="text-align: center;">86</td> </tr> <tr> <td style="text-align: center;">EFO5</td> <td style="text-align: center;">91</td> </tr> <tr> <td style="text-align: center;">EFO6</td> <td style="text-align: center;">94</td> </tr> <tr> <td style="text-align: center;">EFO8</td> <td style="text-align: center;">97</td> </tr> <tr> <td style="text-align: center;">EFO10</td> <td style="text-align: center;">99</td> </tr> <tr> <td style="text-align: center;">EFO12</td> <td style="text-align: center;">100</td> </tr> </tbody> </table>			<b>Net Annual Sediment (TSS) Load Reduction Sizing Summary</b>		Stormceptor Model	TSS Removal Provided (%)	EFO4	86	EFO5	91	EFO6	94	EFO8	97	EFO10	99	EFO12	100
<b>Net Annual Sediment (TSS) Load Reduction Sizing Summary</b>																				
Stormceptor Model	TSS Removal Provided (%)																			
EFO4	86																			
EFO5	91																			
EFO6	94																			
EFO8	97																			
EFO10	99																			
EFO12	100																			
Upstream Flow Control?	Yes																			
Upstream Orifice Control Flow Rate to Stormceptor (L/s):	252.3																			
Peak Conveyance (maximum) Flow Rate (L/s):	252.3																			
		<p><b>Recommended Stormceptor EFO Model: EFO4</b></p> <p><b>Estimated Net Annual Sediment (TSS) Load Reduction (%): 86</b></p> <p><b>Water Quality Runoff Volume Capture (%): &gt; 90</b></p>																		



## Stormceptor® EF Sizing Report

### THIRD-PARTY TESTING AND VERIFICATION

► **Stormceptor® EF and Stormceptor® EFO** are the latest evolutions in the Stormceptor® oil-grit separator (OGS) technology series, and are designed to remove a wide variety of pollutants from stormwater and snowmelt runoff. These technologies have been third-party tested in accordance with the Canadian ETV **Procedure for Laboratory Testing of Oil-Grit Separators** and performance has been third-party verified in accordance with the **ISO 14034 Environmental Technology Verification (ETV)** protocol.

### PERFORMANCE

► **Stormceptor® EF and EFO** remove stormwater pollutants through gravity separation and floatation, and feature a patent-pending design that generates positive removal of total suspended solids (TSS) throughout each storm event, including high-intensity storms. Captured pollutants include sediment, free oils, and sediment-bound pollutants such as nutrients, heavy metals, and petroleum hydrocarbons. Stormceptor is sized to remove a high level of TSS from the frequent rainfall events that contribute the vast majority of annual runoff volume and pollutant load. The technology incorporates an internal bypass to convey excessive stormwater flows from high-intensity storms through the device without resuspension and washout (scour) of previously captured pollutants. Proper routine maintenance ensures high pollutant removal performance and protection of downstream waterways.

### PARTICLE SIZE DISTRIBUTION (PSD)

► The **Canadian ETV PSD** shown in the table below was used, or in part, for this sizing. This is the identical PSD that is referenced in the Canadian ETV **Procedure for Laboratory Testing of Oil-Grit Separators** for both sediment removal testing and scour testing. The Canadian ETV PSD contains a wide range of particle sizes in the sand and silt fractions, and is considered reasonably representative of the particle size fractions found in typical urban stormwater runoff.

Particle Size (µm)	Percent Less Than	Particle Size Fraction (µm)	Percent
1000	100	500-1000	5
500	95	250-500	5
250	90	150-250	15
150	75	100-150	15
100	60	75-100	10
75	50	50-75	5
50	45	20-50	10
20	35	8-20	15
8	20	5-8	10
5	10	2-5	5
2	5	<2	5

Stormceptor®EF Sizing Report

Upstream Flow Controlled Results

Rainfall Intensity (mm / hr)	Percent Rainfall Volume (%)	Cumulative Rainfall Volume (%)	Flow Rate (L/s)	Flow Rate (L/min)	Surface Loading Rate (L/min/m²)	Removal Efficiency (%)	Incremental Removal (%)	Cumulative Removal (%)
0.50	8.6	8.6	0.53	32.0	27.0	100	8.6	8.6
1.00	20.3	29.0	1.07	64.0	53.0	100	20.3	29.0
2.00	16.2	45.2	2.14	128.0	107.0	96	15.6	44.5
3.00	12.0	57.2	3.21	192.0	160.0	88	10.6	55.1
4.00	8.4	65.6	4.27	256.0	214.0	83	7.0	62.1
5.00	5.9	71.6	5.34	321.0	267.0	80	4.8	66.8
6.00	4.6	76.2	6.41	385.0	321.0	78	3.6	70.4
7.00	3.1	79.3	7.48	449.0	374.0	75	2.3	72.7
8.00	2.7	82.0	8.55	513.0	427.0	73	2.0	74.7
9.00	3.3	85.3	9.62	577.0	481.0	70	2.3	77.1
10.00	2.3	87.6	10.69	641.0	534.0	68	1.6	78.6
11.00	1.6	89.2	11.75	705.0	588.0	66	1.0	79.7
12.00	1.3	90.5	12.82	769.0	641.0	64	0.8	80.5
13.00	1.7	92.2	13.89	834.0	695.0	64	1.1	81.6
14.00	1.2	93.5	14.96	898.0	748.0	64	0.8	82.4
15.00	1.2	94.6	16.03	962.0	801.0	63	0.7	83.1
16.00	0.7	95.3	17.10	1026.0	855.0	63	0.4	83.6
17.00	0.7	96.1	18.17	1090.0	908.0	62	0.5	84.0
18.00	0.4	96.5	19.24	1154.0	962.0	62	0.2	84.3
19.00	0.4	96.9	20.30	1218.0	1015.0	61	0.3	84.5
20.00	0.2	97.1	21.37	1282.0	1069.0	60	0.1	84.6
21.00	0.5	97.5	22.44	1346.0	1122.0	59	0.3	84.9
22.00	0.2	97.8	23.51	1411.0	1175.0	58	0.1	85.1
23.00	1.0	98.8	24.58	1475.0	1229.0	56	0.6	85.6
24.00	0.3	99.1	25.65	1539.0	1282.0	55	0.1	85.8
25.00	0.9	100.0	26.72	1603.0	1336.0	54	0.5	86.3
30.00	0.9	100.9	32.06	1924.0	1603.0	46	0.4	86.7
35.00	-0.9	100.0	37.40	2244.0	1870.0	39	0.0	86.3
40.00	0.0	100.0	42.75	2565.0	2137.0	34	0.0	86.3
45.00	0.0	100.0	48.09	2885.0	2404.0	31	0.0	86.3
<b>Estimated Net Annual Sediment (TSS) Load Reduction =</b>								<b>86 %</b>

Climate Station ID: 6105978 Years of Rainfall Data: 20



Stormceptor® EF Sizing Report

RAINFALL DATA FROM OTTAWA CDA RCS RAINFALL STATION

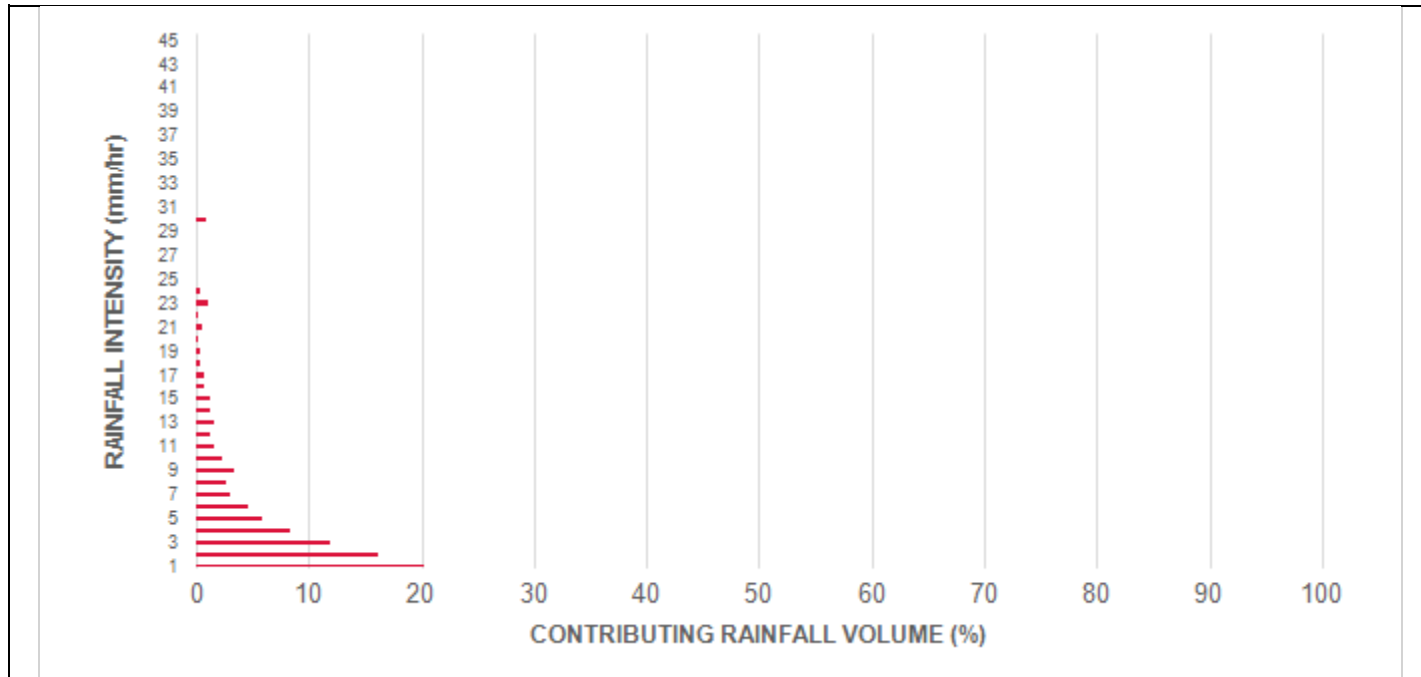

INCREMENTAL AND CUMULATIVE TSS REMOVAL FOR THE RECOMMENDED STORMCEPTOR® MODEL

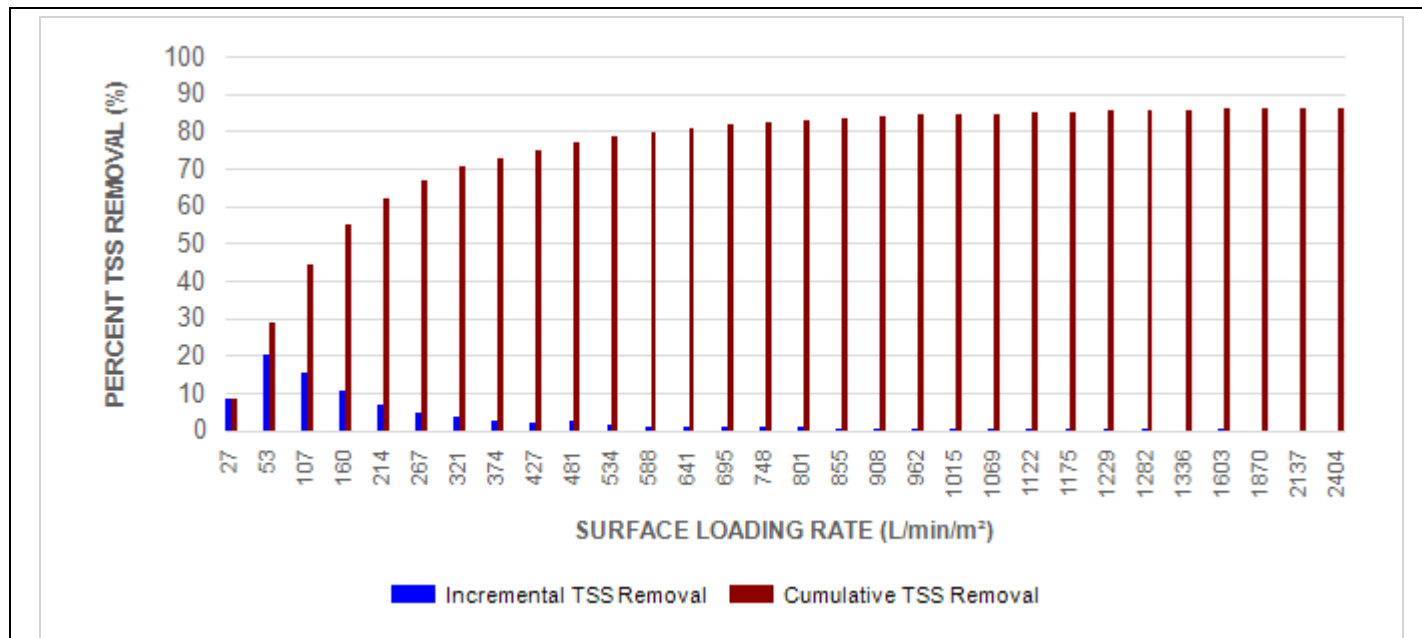

## Stormceptor® EF Sizing Report

### Maximum Pipe Diameter / Peak Conveyance

Stormceptor EF / EFO	Model Diameter		Min Angle Inlet / Outlet Pipes	Max Inlet Pipe Diameter		Max Outlet Pipe Diameter		Peak Conveyance Flow Rate	
	(m)	(ft)		(mm)	(in)	(mm)	(in)	(L/s)	(cfs)
EF4 / EFO4	1.2	4	90	609	24	609	24	425	15
EF5 / EFO5	1.5	5	90	762	30	762	30	710	25
EF6 / EFO6	1.8	6	90	914	36	914	36	990	35
EF8 / EFO8	2.4	8	90	1219	48	1219	48	1700	60
EF10 / EFO10	3.0	10	90	1828	72	1828	72	2830	100
EF12 / EFO12	3.6	12	90	1828	72	1828	72	2830	100

### SCOUR PREVENTION AND ONLINE CONFIGURATION

► **Stormceptor® EF and EFO** feature an internal bypass and superior scour prevention technology that have been demonstrated in third-party testing according to the scour testing provisions of the Canadian ETV **Procedure for Laboratory Testing of Oil-Grit Separators**, and the exceptional scour test performance has been third-party verified in accordance with the ISO 14034 ETV protocol. As a result, Stormceptor EF and EFO are approved for online installation, eliminating the need for costly additional bypass structures, piping, and installation expense.

### DESIGN FLEXIBILITY

► **Stormceptor® EF and EFO** offers design flexibility in one simplified platform, accepting stormwater flow from a single inlet pipe or multiple inlet pipes, and/or surface runoff through an inlet grate. The device can also serve as a junction structure, accommodate a 90-degree inlet-to-outlet bend angle, and can be modified to ensure performance in submerged conditions.

### OIL CAPTURE AND RETENTION

► While Stormceptor® EF will capture and retain oil from dry weather spills and low intensity runoff, **Stormceptor® EFO** has demonstrated superior oil capture and greater than 99% oil retention in third-party testing according to the light liquid re-entrainment testing provisions of the Canadian ETV **Procedure for Laboratory Testing of Oil-Grit Separators**. Stormceptor EFO is recommended for sites where oil capture and retention is a requirement.

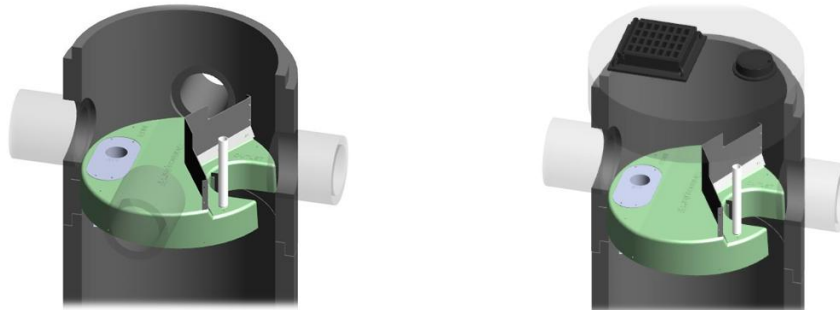

Stormceptor®EF Sizing Report

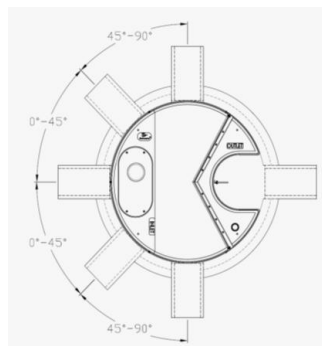

**INLET-TO-OUTLET DROP**

Elevation differential between inlet and outlet pipe inverts is dictated by the angle at which the inlet pipe(s) enters the unit.

0° - 45° : The inlet pipe is 1-inch (25mm) higher than the outlet pipe.

45° - 90° : The inlet pipe is 2-inches (50mm) higher than the outlet pipe.

**HEAD LOSS**

The head loss through Stormceptor EF is similar to that of a 60-degree bend structure. The applicable K value for calculating minor losses through the unit is 1.1. For submerged conditions the applicable K value is 3.0.

**Pollutant Capacity**

Stormceptor EF / EFO	Model Diameter		Depth (Outlet Pipe Invert to Sump Floor)		Oil Volume		Recommended Sediment Maintenance Depth *		Maximum Sediment Volume *		Maximum Sediment Mass **	
	(m)	(ft)	(m)	(ft)	(L)	(Gal)	(mm)	(in)	(L)	(ft³)	(kg)	(lb)
EF4 / EFO4	1.2	4	1.52	5.0	265	70	203	8	1190	42	1904	5250
EF5 / EFO5	1.5	5	1.62	5.3	420	111	305	10	2124	75	2612	5758
EF6 / EFO6	1.8	6	1.93	6.3	610	160	305	12	3470	123	5552	15375
EF8 / EFO8	2.4	8	2.59	8.5	1070	280	610	24	8780	310	14048	38750
EF10 / EFO10	3.0	10	3.25	10.7	1670	440	610	24	17790	628	28464	78500
EF12 / EFO12	3.6	12	3.89	12.8	2475	655	610	24	31220	1103	49952	137875

\*Increased sump depth may be added to increase sediment storage capacity

\*\* Average density of wet packed sediment in sump = 1.6 kg/L (100 lb/ft³ )

Feature	Benefit	Feature Appeals To
Patent-pending enhanced flow treatment and scour prevention technology	Superior, verified third-party performance	Regulator, Specifying & Design Engineer
Third-party verified light liquid capture and retention for EFO version	Proven performance for fuel/oil hotspot locations	Regulator, Specifying & Design Engineer, Site Owner
Functions as bend, junction or inlet structure	Design flexibility	Specifying & Design Engineer
Minimal drop between inlet and outlet	Site installation ease	Contractor
Large diameter outlet riser for inspection and maintenance	Easy maintenance access from grade	Maintenance Contractor & Site Owner

**STANDARD STORMCEPTOR EF/EFO DRAWINGS**

For standard details, please visit <http://www.imbriumsystems.com/stormwater-treatment-solutions/stormceptor-ef>

**STANDARD STORMCEPTOR EF/EFO SPECIFICATION**

For specifications, please visit <http://www.imbriumsystems.com/stormwater-treatment-solutions/stormceptor-ef>

## STANDARD PERFORMANCE SPECIFICATION FOR “OIL GRIT SEPARATOR” (OGS) STORMWATER QUALITY TREATMENT DEVICE

### PART 1 – GENERAL

#### 1.1 WORK INCLUDED

This section specifies requirements for selecting, sizing, and designing an underground Oil Grit Separator (OGS) device for stormwater quality treatment, with third-party testing results and a Statement of Verification in accordance with ISO 14034 Environmental Management – Environmental Technology Verification (ETV).

#### 1.2 REFERENCE STANDARDS & PROCEDURES

ISO 14034:2016 Environmental management – Environmental technology verification (ETV)

Canadian Environmental Technology Verification (ETV) Program's **Procedure for Laboratory Testing of Oil-Grit Separators**

#### 1.3 SUBMITTALS

1.3.1 All submittals, including sizing reports & shop drawings, shall be submitted upon request with each order to the contractor then forwarded to the Engineer of Record for review and acceptance. Shop drawings shall detail all OGS components, elevations, and sequence of construction.

1.3.2 Alternative devices shall have features identical to or greater than the specified device, including: treatment chamber diameter, treatment chamber wet volume, sediment storage volume, and oil storage volume.

1.3.3 Unless directed otherwise by the Engineer of Record, OGS stormwater quality treatment product substitutions or alternatives submitted within ten days prior to project bid shall not be accepted. All alternatives or substitutions submitted shall be signed and sealed by a local registered Professional Engineer, based on the exact same criteria detailed in Section 3, in entirety, subject to review and approval by the Engineer of Record.

### PART 2 – PRODUCTS

#### 2.1 OGS POLLUTANT STORAGE

The OGS device shall include a sump for sediment storage, and a protected volume for the capture and storage of petroleum hydrocarbons and buoyant gross pollutants. The minimum sediment & petroleum hydrocarbon storage capacity shall be as follows:

2.1.1	4 ft (1219 mm) Diameter OGS Units:	1.19 m <sup>3</sup> sediment / 265 L oil
	5 ft (1524 mm) Diameter OGS Units:	1.95 m <sup>3</sup> sediment / 420 L oil
	6 ft (1829 mm) Diameter OGS Units:	3.48 m <sup>3</sup> sediment / 609 L oil
	8 ft (2438 mm) Diameter OGS Units:	8.78 m <sup>3</sup> sediment / 1,071 L oil
	10 ft (3048 mm) Diameter OGS Units:	17.78 m <sup>3</sup> sediment / 1,673 L oil
	12 ft (3657 mm) Diameter OGS Units:	31.23 m <sup>3</sup> sediment / 2,476 L oil

### PART 3 – PERFORMANCE & DESIGN

#### 3.1 GENERAL

The OGS stormwater quality treatment device shall be verified in accordance with ISO 14034:2016 Environmental

## Stormceptor® EF Sizing Report

management – Environmental technology verification (ETV). The OGS stormwater quality treatment device shall remove oil, sediment and gross pollutants from stormwater runoff during frequent wet weather events, and retain these pollutants during less frequent high flow wet weather events below the insert within the OGS for later removal during maintenance. The Manufacturer shall have at least ten (10) years of local experience, history and success in engineering design, manufacturing and production and supply of OGS stormwater quality treatment device systems, acceptable to the Engineer of Record.

### 3.2 SIZING METHODOLOGY

The OGS device shall be engineered, designed and sized to provide stormwater quality treatment based on treating a minimum of 90 percent of the average annual runoff volume and a minimum removal of an annual average 60% of the sediment (TSS) load based on the Particle Size Distribution (PSD) specified in the sizing report for the specified device. Sizing of the OGS shall be determined by use of a minimum ten (10) years of local historical rainfall data provided by Environment Canada. Sizing shall also be determined by use of the sediment removal performance data derived from the ISO 14034 ETV third-party verified laboratory testing data from testing conducted in accordance with the Canadian ETV protocol Procedure for Laboratory Testing of Oil-Grit Separators, as follows:

3.2.1 Sediment removal efficiency for a given surface loading rate and its associated flow rate shall be based on sediment removal efficiency demonstrated at the seven (7) tested surface loading rates specified in the protocol, ranging 40 L/min/m<sup>2</sup> to 1400 L/min/m<sup>2</sup>, and as stated in the ISO 14034 ETV Verification Statement for the OGS device.

3.2.2 Sediment removal efficiency for surface loading rates between 40 L/min/m<sup>2</sup> and 1400 L/min/m<sup>2</sup> shall be based on linear interpolation of data between consecutive tested surface loading rates.

3.2.3 Sediment removal efficiency for surface loading rates less than the lowest tested surface loading rate of 40 L/min/m<sup>2</sup> shall be assumed to be identical to the sediment removal efficiency at 40 L/min/m<sup>2</sup>. No extrapolation shall be allowed that results in a sediment removal efficiency that is greater than that demonstrated at 40 L/min/m<sup>2</sup>.

3.2.4 Sediment removal efficiency for surface loading rates greater than the highest tested surface loading rate of 1400 L/min/m<sup>2</sup> shall assume zero sediment removal for the portion of flow that exceeds 1400 L/min/m<sup>2</sup>, and shall be calculated using a simple proportioning formula, with 1400 L/min/m<sup>2</sup> in the numerator and the higher surface loading rate in the denominator, and multiplying the resulting fraction times the sediment removal efficiency at 1400 L/min/m<sup>2</sup>.

The OGS device shall also have sufficient annual sediment storage capacity as specified and calculated in Section 2.1.

### 3.3 CANADIAN ETV or ISO 14034 ETV VERIFICATION OF SCOUR TESTING

The OGS device shall have Canadian ETV or ISO 14034 ETV Verification of third-party scour testing conducted in accordance with the Canadian ETV Program's **Procedure for Laboratory Testing of Oil-Grit Separators**.

3.3.1 To be acceptable for on-line installation, the OGS device must demonstrate an average scour test effluent concentration less than 10 mg/L at each surface loading rate tested, up to and including 2600 L/min/m<sup>2</sup>.

### 3.4 LIGHT LIQUID RE-ENTRAINMENT SIMULATION TESTING

The OGS device shall have Canadian ETV or ISO 14034 ETV Verification of completed third-party Light Liquid Re-entrainment Simulation Testing in accordance with the Canadian ETV **Program's Procedure for Laboratory Testing of Oil-Grit Separators**, with results reported within the Canadian ETV or ISO 14034 ETV verification. This re-entrainment testing is conducted with the device pre-loaded with low density polyethylene (LDPE) plastic beads as a surrogate for light liquids such as oil and fuel. Testing is conducted on the same OGS unit tested for sediment removal to assess whether light liquids captured after a spill are effectively retained at high flow rates.

Stormceptor®**EF** Sizing Report

3.4.1 For an OGS device to be an acceptable stormwater treatment device on a site where vehicular traffic occurs and the potential for an oil or fuel spill exists, the OGS device must have reported verified performance results of greater than 99% cumulative retention of LDPE plastic beads for the five specified surface loading rates (ranging 200 L/min/m<sup>2</sup> to 2600 L/min/m<sup>2</sup>) in accordance with the Light Liquid Re-entrainment Simulation Testing within the Canadian ETV Program's **Procedure for Laboratory Testing of Oil-Grit Separators**. However, an OGS device shall not be allowed if the Light Liquid Re-entrainment Simulation Testing was performed with screening components within the OGS device that are effective at retaining the LDPE plastic beads, but would not be expected to retain light liquids such as oil and fuel.

# VERIFICATION STATEMENT

## GLOBE Performance Solutions

Verifies the performance of

### Stormceptor® EF and EFO Oil-Grit Separators

Developed by Imbrium Systems, Inc.,  
Whitby, Ontario, Canada

**Registration: GPS-ETV\_VR2023-11-15\_Imbrium-SC**

In accordance with

**ISO 14034:2016**

**Environmental management —  
Environmental technology verification (ETV)**



John D. Wiebe, PhD  
Executive Chairman  
GLOBE Performance Solutions

November 15, 2023  
Vancouver, BC, Canada



Verification Body  
GLOBE Performance Solutions  
404 – 999 Canada Place | Vancouver, B.C | Canada |V6C 3E2

## Technology description and application

The Stormceptor® EF and EFO are treatment devices designed to remove oil, sediment, trash, debris, and pollutants attached to particulates from Stormwater and snowmelt runoff. The device takes the place of a conventional manhole within a storm drain system and offers design flexibility that works with various site constraints. The EFO is designed with a shorter bypass weir height, which accepts lower surface loading rate into the sump, thereby reducing re-entrainment of captured free floating light liquids.

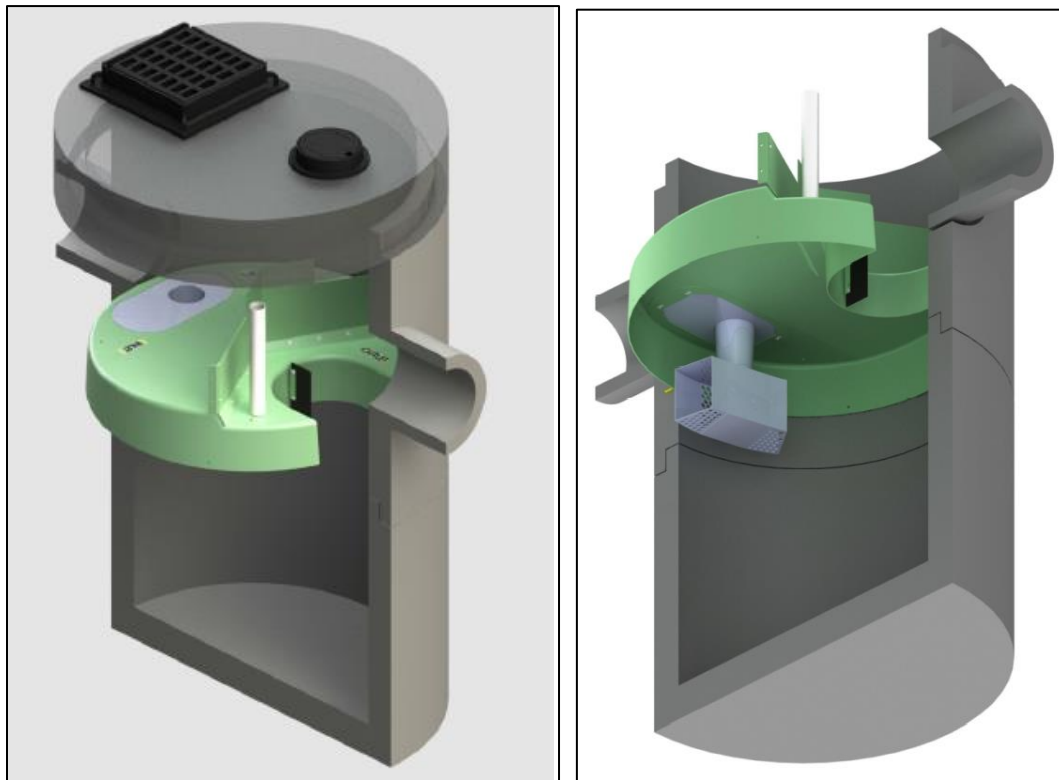

Figure 1. Graphic of typical inline Stormceptor® unit and core components.

Stormwater and snowmelt runoff enters the Stormceptor® EF/EFO's upper chamber through the inlet pipe(s) or a surface inlet grate. An insert divides the unit into lower and upper chambers and incorporates a weir to reduce influent velocity and separate influent (untreated) from effluent (treated) flows. Influent water ponds upstream of the insert's weir providing driving head for the water flowing downwards into the drop pipe where a vortex pulls the water into the lower chamber. The water diffuses at lower velocities in multiple directions through the drop pipe outlet openings. Oil and other floatables rise up and are trapped beneath the insert, while sediments undergo gravitational settling to the sump's bottom. Water from the sump can exit by flowing upward to the outlet riser onto the top side of the insert and downstream of the weir, where it discharges through the outlet pipe.

Maximum flow rate into the lower chamber is a function of weir height and drop pipe orifice diameter. The Stormceptor® EF and EFO are designed to allow a surface loading rate of 1135 L/min/m<sup>2</sup> (27.9 gal/min/ft<sup>2</sup>) and 535 L/min/m<sup>2</sup> (13.1 gal/min/ft<sup>2</sup>) into the lower chamber, respectively. When prescribed surface loading rates are exceeded, ponding water can overtop the weir height and bypass the lower treatment chamber, exiting directly through the outlet pipe. Hydraulic testing and scour testing demonstrate that the internal bypass effectively prevents scour at all bypass flow rates. Increasing the bypass flow rate does not increase the orifice-controlled flow rate into the lower treatment chamber where sediment is stored. This internal bypass feature allows for in-line installation, avoiding the cost of

additional bypass structures. During bypass, treatment continues in the lower chamber at the maximum flow rate. The Stormceptor® EFO's lower design surface loading rate is favorable for minimizing re-entrainment and washout of captured light liquids. Inspection of Stormceptor® EF and EFO devices is performed from grade by inserting a sediment probe through the outlet riser and an oil dipstick through the oil inspection pipe. The unit can be maintained by using a vacuum hose through the outlet riser.

## Performance conditions

The data and results published in this Technology Fact Sheet were obtained from the testing program conducted on the Imbrium Systems Inc.'s Stormceptor® EF4 and EFO4 Oil-Grit Separators, in accordance with the Procedure for Laboratory Testing of Oil-Grit Separators (Version 3.0, June 2014). The Procedure was prepared by the Toronto and Region Conservation Authority (TRCA) for Environment Canada's Environmental Technology Verification (ETV) Program. A copy of the Procedure may be accessed on the Canadian ETV website at [www.etvcanada.ca](http://www.etvcanada.ca).

## Performance claim(s)

### Capture test<sup>a</sup>:

During the capture test, the Stormceptor® EF4 OGS device, with a false floor set to 50% of the manufacturer's recommended maximum sediment storage depth and a constant influent test sediment concentration of 200 mg/L, removes 70, 64, 54, 48, 46, 44, and 49 percent of influent sediment by mass at surface loading rates of 40, 80, 200, 400, 600, 1000, and 1400 L/min/m<sup>2</sup>, respectively.

Stormceptor® EFO4, with a false floor set to 50% of the manufacturer's recommended maximum sediment storage depth and a constant influent test sediment concentration of 200 mg/L, removes 70, 64, 54, 48, 42, 40, and 34 percent of influent sediment by mass at surface loading rates of 40, 80, 200, 400, 600, 1000, and 1400 L/min/m<sup>2</sup>, respectively.

### Scour test<sup>a</sup>:

During the scour test, the Stormceptor® EF4 and Stormceptor® EFO4 OGS devices, with 10.2 cm (4 inches) of test sediment pre-loaded onto a false floor reaching 50% of the manufacturer's recommended maximum sediment storage depth, generate corrected effluent concentrations of 4.6, 0.7, 0, 0.2, and 0.4 mg/L at 5-minute duration surface loading rates of 200, 800, 1400, 2000, and 2600 L/min/m<sup>2</sup>, respectively.

### Light liquid re-entrainment test<sup>a</sup>:

During the light liquid re-entrainment test, the Stormceptor® EFO4 OGS device with surrogate low-density polyethylene beads preloaded within the lower chamber oil collection zone, representing a floating light liquid volume equal to a depth of 50.8 mm over the sedimentation area, retained 100, 99.5, 99.8, 99.8, and 99.9 percent of loaded beads by mass during the 5-minute duration surface loading rates of 200, 800, 1400, 2000, and 2600 L/min/m<sup>2</sup>.

---

<sup>a</sup> The claim can be applied to other units smaller or larger than the tested unit as long as the untested units meet the scaling rule specified in the Procedure for Laboratory of Testing of Oil Grit Separators (Version 3.0, June 2014)

## Performance results

The test sediment consisted of ground silica (1 – 1000 micron) with a specific gravity of 2.65, uniformly mixed to meet the particle size distribution specified in the testing procedure. The *Procedure for Laboratory Testing of Oil Grit Separators* requires that the three sample average of the test sediment particle size distribution (PSD) meet the specified PSD percent less than values within a boundary threshold of 6%. The comparison of the average test sediment PSD to the CETV specified PSD in Figure 2 indicates that the test sediment used for the capture and scour tests met this condition.

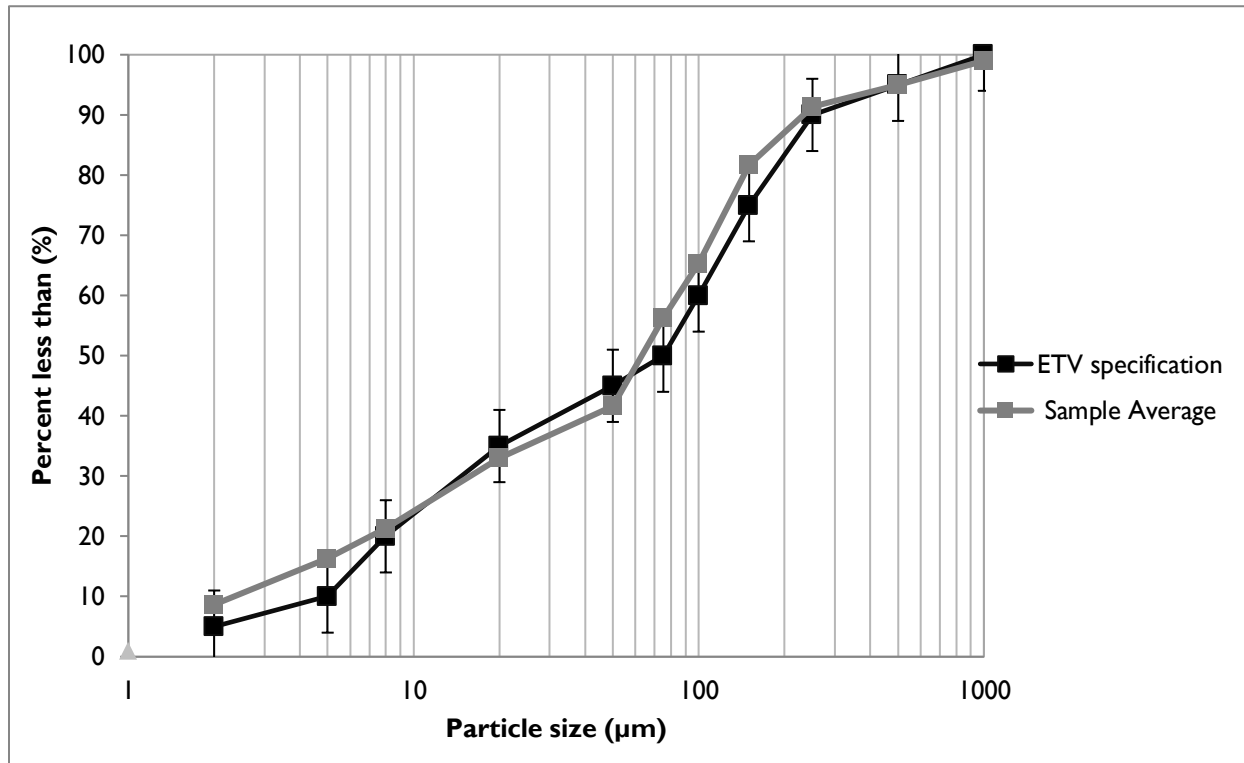

Figure 2. The three sample average particle size distribution (PSD) of the test sediment used for the capture and scour test compared to the specified PSD.

The capacity of the device to retain sediment was determined at seven surface loading rates using the modified mass balance method. This method involved measuring the mass and particle size distribution of the injected and retained sediment for each test run. Performance was evaluated with a false floor simulating the technology filled to 50% of the manufacturer’s recommended maximum sediment storage depth. The test was carried out with clean water that maintained a sediment concentration below 20 mg/L. Based on these conditions, removal efficiencies for individual particle size classes and for the test sediment as a whole were determined for each of the tested surface loading rates (Table 1). Since the EF and EFO models are identical except for the weir height, which bypasses flows from the EFO model at a surface loading rate of 535 L/min/m<sup>2</sup> (13.1 gpm/ft<sup>2</sup>), sediment capture tests at surface loading rates from 40 to 400 L/min/m<sup>2</sup> were only performed on the EF unit. Surface loading rates of 600, 1000, and 1400 L/min/m<sup>2</sup> were tested on both units separately. Results for the EFO model at these higher flow rates are presented in Table 2.

In some instances, the removal efficiencies were above 100% for certain particle size fractions. These discrepancies are not unique to any one test laboratory and may be attributed to errors relating to the blending of sediment, collection of representative samples for laboratory submission, and laboratory

analysis of PSD. Due to these errors, caution should be exercised in applying the removal efficiencies by particle size fraction for the purposes of sizing the tested device (see [Bulletin # CETV 2016-11-0001](#)). The results for “all particle sizes by mass balance” (see Table 1 and 2) are based on measurements of the total injected and retained sediment mass, and are therefore not subject to blending, sampling or PSD analysis errors.

Table 1. Removal efficiencies (%) of the EF4 at specified surface loading rates

Particle size fraction (µm)	Surface loading rate (L/min/m <sup>2</sup> )						
	40	80	200	400	600	1000	1400
>500	90	58	58	100*	86	72	100*
250 - 500	100*	100*	100	100*	100*	100*	100*
150 - 250	90	82	26	100*	100*	67	90
105 - 150	100*	100*	100*	100*	100*	100*	100
75 - 105	100*	92	74	82	77	68	76
53 - 75	Undefined <sup>a</sup>	56	100*	72	69	50	80
20 - 53	54	100*	54	33	36	40	31
8 - 20	67	52	25	21	17	20	20
5 – 8	33	29	11	12	9	7	19
<5	13	0	0	0	0	0	4
<b>All particle sizes by mass balance</b>	<b>70.4</b>	<b>63.8</b>	<b>53.9</b>	<b>47.5</b>	<b>46.0</b>	<b>43.7</b>	<b>49.0</b>

<sup>a</sup> An outlier in the feed sample sieve data resulted in a negative removal efficiency for this size fraction.

\* Removal efficiencies were calculated to be above 100%. Calculated values ranged between 101 and 171% (average 128%). See text and [Bulletin # CETV 2016-11-0001](#) for more information.

Table 2. Removal efficiencies (%) of the EFO4 at surface loading rates above the bypass rate of 535 L/min/m<sup>2</sup>

Particle size fraction (µm)	Surface loading rate (L/min/m <sup>2</sup> )		
	600	1000	1400
>500	89	83	100*
250 - 500	90	100*	92
150 - 250	90	67	100*
105 - 150	85	92	77
75 - 105	80	71	65
53 - 75	60	31	36
20 - 53	33	43	23
8 - 20	17	23	15
5 – 8	10	3	3
<5	0	0	0
<b>All particle sizes by mass balance</b>	<b>41.7</b>	<b>39.7</b>	<b>34.2</b>

\* Removal efficiencies were calculated to be above 100%. Calculated values ranged between 103 and 111% (average 107%). See text and [Bulletin # CETV 2016-11-0001](#) for more information.

Figure 3 compares the particle size distribution (PSD) of the three sample average of the test sediment to the PSD of the sediment retained by the EF4 at each of the tested surface loading rates. Figure 4 shows the same graph for the EFO4 unit at surface loading rates above the bypass rate of 535 L/min/m<sup>2</sup>.

As expected, the capture efficiency for fine particles in both units was generally found to decrease as surface loading rates increased.

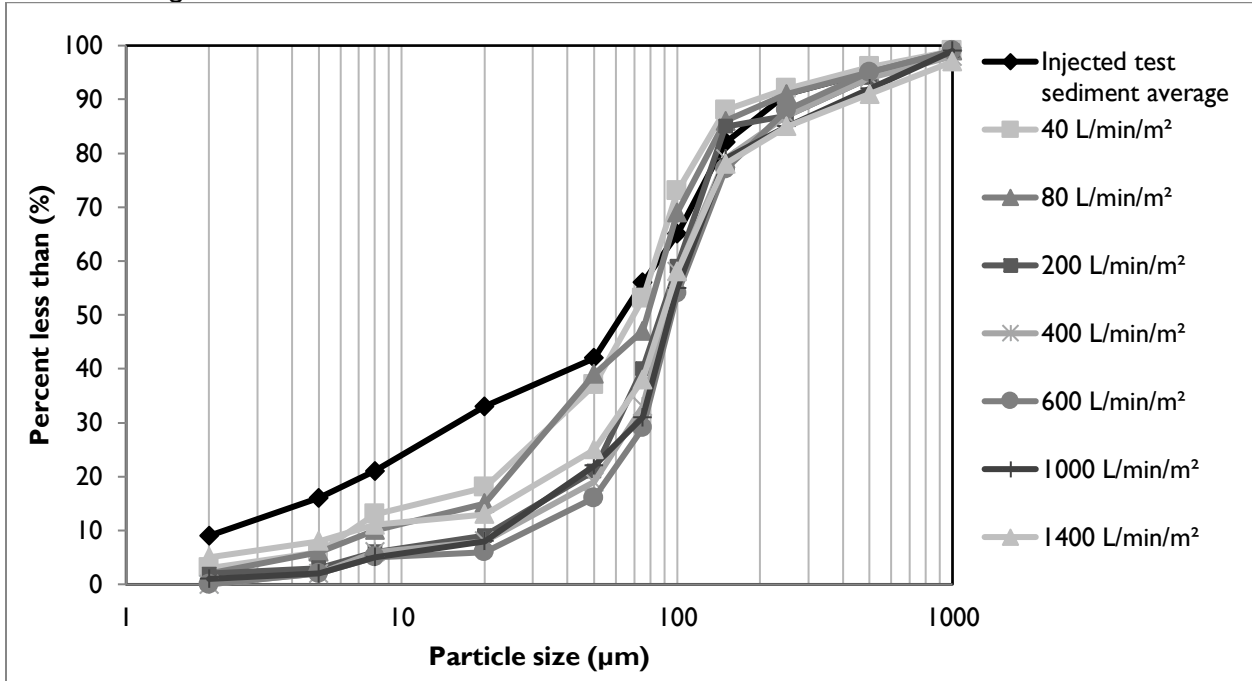

Figure 3. Particle size distribution of sediment retained in the EF4 in relation to the injected test sediment average.

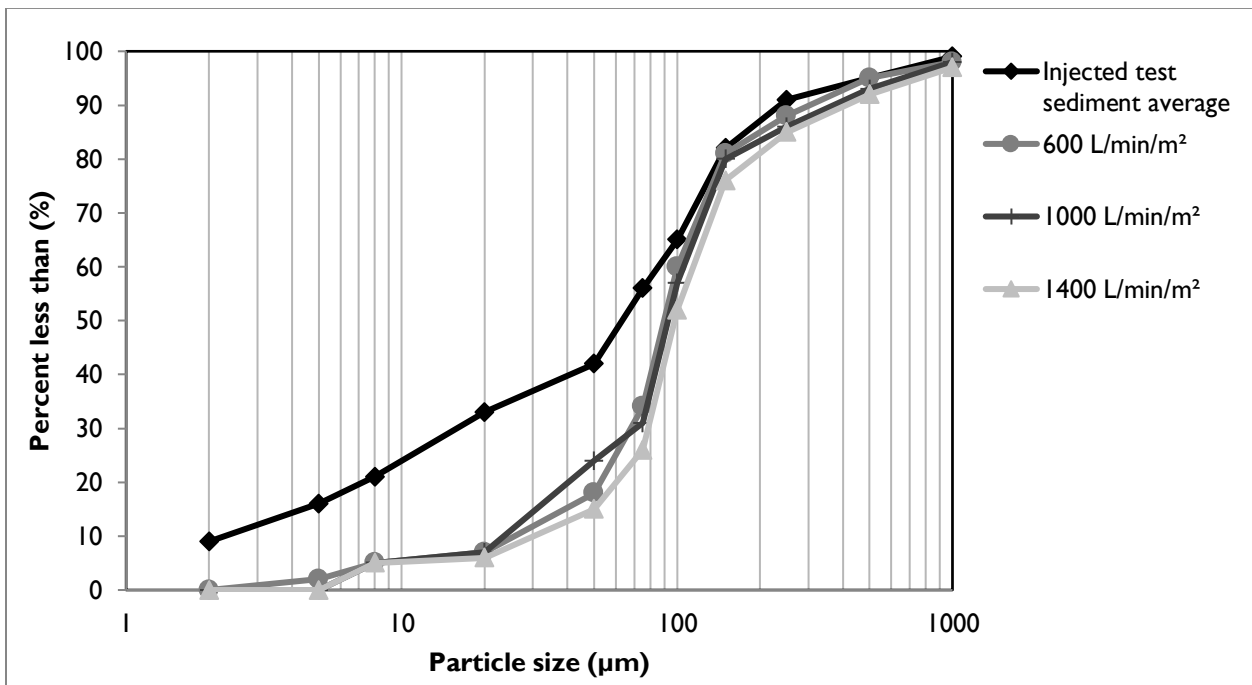

Figure 4. Particle size distribution of sediment retained in the EFO4 in relation to the injected test sediment average at surface loading rates above the bypass rate of 535 L/min/m<sup>2</sup>

Table 4 shows the results of the sediment scour and re-suspension test for the EF4 unit. The EFO4 was not tested as it was reasonably assumed that scour rates would be lower given that flow bypass occurs at a lower surface loading rate. The scour test involved preloading 10.2 cm of fresh test sediment into

the sedimentation sump of the device. The sediment was placed on a false floor to mimic a device filled to 50% of the maximum recommended sediment storage depth. Clean water was run through the device at five surface loading rates over a 30 minute period. Each flow rate was maintained for 5 minutes with a one minute transition time between flow rates. Effluent samples were collected at one minute sampling intervals and analyzed for Suspended Sediment Concentration (SSC) and PSD by recognized methods. The effluent samples were subsequently adjusted based on the background concentration of the influent water. Typically, the smallest 5% of particles captured during the 40 L/min/m<sup>2</sup> sediment capture test is also used to adjust the concentration, as per the method described in [Bulletin # CETV 2016-09-0001](#). However, since the composites of effluent concentrations were below the Reporting Detection Limit of the Laser Diffraction PSD methodology, this adjustment was not made. Results showed average adjusted effluent sediment concentrations below 5 mg/L at all tested surface loading rates.

It should be noted that the EF4 starts to internally bypass water at 1135 L/min/m<sup>2</sup>, potentially resulting in the dilution of effluent concentrations, which would not normally occur under typical field conditions because the field influent concentration would contain a much higher sediment concentration than during the lab test. Recalculation of effluent concentrations to account for dilution at surface loading rates above the bypass rate showed sediment effluent concentrations to be below 1.6 mg/L.

Table 4. Scour test adjusted effluent sediment concentration.

Run	Surface loading rate (L/min/m <sup>2</sup> )	Run time (min)	Background sample concentration (mg/L)	Adjusted effluent suspended sediment concentration (mg/L) <sup>a</sup>	Average (mg/L)
1	200	1:00	<RDL	11.9	4.6
		2:00		7.0	
		3:00		4.4	
		4:00		2.2	
		5:00		1.0	
		6:00		1.2	
2	800	7:00	<RDL	1.1	0.7
		8:00		0.9	
		9:00		0.6	
		10:00		1.4	
		11:00		0.1	
		12:00		0	
3	1400	13:00	<RDL	0	0
		14:00		0.1	
		15:00		0	
		16:00		0	
		17:00		0	
		18:00		0	
4	2000	19:00	1.2	0.2	0.2
		20:00		0	
		21:00		0	
		22:00		0.7	
		23:00		0	
		24:00		0.4	

5	2600	25:00	1.6	0.3	0.4
		26:00		0.4	
		27:00		0.7	
		28:00		0.4	
		29:00		0.2	
		30:00		0.4	

<sup>a</sup> The adjusted effluent suspended sediment concentration represents the actual measured effluent concentration minus the background concentration. For more information see [Bulletin # CETV 2016-09-0001](#).

The results of the light liquid re-entrainment test used to evaluate the unit’s capacity to prevent re-entrainment of light liquids are reported in Table 5. The test involved preloading 58.3 L (corresponding to a 5 cm depth over the collection sump area of 1.17m<sup>2</sup>) of surrogate low-density polyethylene beads within the oil collection skirt and running clean water through the device continuously at five surface loading rates (200, 800, 1400, 2000, and 2600 L/min/m<sup>2</sup>). Each flow rate was maintained for 5 minutes with approximately 1 minute transition time between flow rates. The effluent flow was screened to capture all re-entrained pellets throughout the test.

Table 5. Light liquid re-entrainment test results for the EFO4.

Surface Loading Rate (L/min/m <sup>2</sup> )	Time Stamp	Amount of Beads Re-entrained			
		Mass (g)	Volume (L) <sup>a</sup>	% of Pre-loaded Mass Re-entrained	% of Pre-loaded Mass Retained
200	62	0	0	0.00	100
800	247	168.45	0.3	0.52	99.48
1400	432	51.88	0.09	0.16	99.83
2000	617	55.54	0.1	0.17	99.84
2600	802	19.73	0.035	0.06	99.94
Total Re-entrained		295.60	0.525	0.91	--
Total Retained		32403	57.78	--	99.09
Total Loaded		32699	58.3	--	--

<sup>a</sup> Determined from bead bulk density of 0.56074 g/cm<sup>3</sup>

## Variations from testing Procedure

The following minor deviations from the *Procedure for Laboratory Testing of Oil-Grit Separators* (Version 3.0, June 2014) have been noted:

1. During the capture test, the 40 L/min/m<sup>2</sup> and 80 L/min/m<sup>2</sup> surface loading rates were evaluated over 3 and 2 days respectively due to the long duration needed to feed the required minimum of 11.3 kg of test sediment into the unit at these lower flow rates. Pumps were shut down at the end of each intermediate day, and turned on again the following morning. The target flow rate was re-established within 30 seconds of switching on the pump. This procedure may have allowed sediments to be captured that otherwise may have exited the unit if the test was continuous. On the basis of practical considerations, this variance was approved by the verifier prior to testing.

2. During the scour test, the coefficient of variation (COV) for the lowest flow rate tested (200 L/min/m<sup>2</sup>) was 0.07, which exceeded the specified limit of 0.04 target specified in the OGS Procedure. A pump capable of attaining the highest flow rate of 3036 L/min had difficulty maintaining the lowest flow of 234 L/min but still remained within +/- 10% of the target flow and is viewed as having very little impact on the observed results. Similarly, for the light liquid re-entrainment test the COV for the flow rate of the 200 L/min/m<sup>2</sup> run was 0.049, exceeding the limit of 0.04, but is believed to introduce negligible bias.
3. Due to pressure build up in the filters, the runs at 1000 L/min/m<sup>2</sup> for the Stormceptor® EF4 and 1000 and 1400 L/min/m<sup>2</sup> for the Stormceptor® EFO4 were slightly shorter than the target. The run times were 54, 59 and 43 minutes respectively, versus targets of 60 and 50 minutes. The final feed samples were timed to coincide with the end of the run. Since >25 lbs of sediment was fed, the shortened time did not invalidate the runs.

## Verification

The verification was completed by the Verification Expert, Toronto and Region Conservation Authority, contracted by GLOBE Performance Solutions, using the International Standard **ISO 14034:2016 Environmental management – Environmental technology verification (ETV)**. Data and information provided by Imbrium Systems Inc. to support the performance claim included the following: Performance test report prepared by Good Harbour Laboratories, and dated September 8, 2017; the report is based on testing completed in accordance with the Procedure for Laboratory Testing of Oil-Grit Separators (Version 3.0, June 2014).

## What is ISO 14034:2016 Environmental management – Environmental technology verification (ETV)?

ISO 14034:2016 specifies principles, procedures and requirements for environmental technology verification (ETV), and was developed and published by the *International Organization for Standardization (ISO)*. The objective of ETV is to provide credible, reliable and independent verification of the performance of environmental technologies. An environmental technology is a technology that either results in an environmental added value or measures parameters that indicate an environmental impact. Such technologies have an increasingly important role in addressing environmental challenges and achieving sustainable development.

**For more information on the Stormceptor® EF and EFO OGS please contact:**

Imbrium Systems, Inc.  
407 Fairview Drive  
Whitby, ON  
L1N 3A9, Canada  
Tel: 416-960-9900  
info@imbriumsystems.com

**For more information on ISO 14034:2016 / ETV please contact:**

GLOBE Performance Solutions  
World Trade Centre  
404 – 999 Canada Place  
Vancouver, BC  
V6C 3E2 Canada  
Tel: 604-695-5018 / Toll Free: 1-855-695-5018  
etv@globeperformance.com

### **Limitation of verification - Registration: GPS-ETV\_VR2023-11-15\_Imbrium-SC**

GLOBE Performance Solutions and the Verification Expert provide the verification services solely on the basis of the information supplied by the applicant or vendor and assume no liability thereafter. The responsibility for the information supplied remains solely with the applicant or vendor and the liability for the purchase, installation, and operation (whether consequential or otherwise) is not transferred to any other party as a result of the verification.

# *Stormceptor*<sup>®</sup>

## **Owner's Manual**

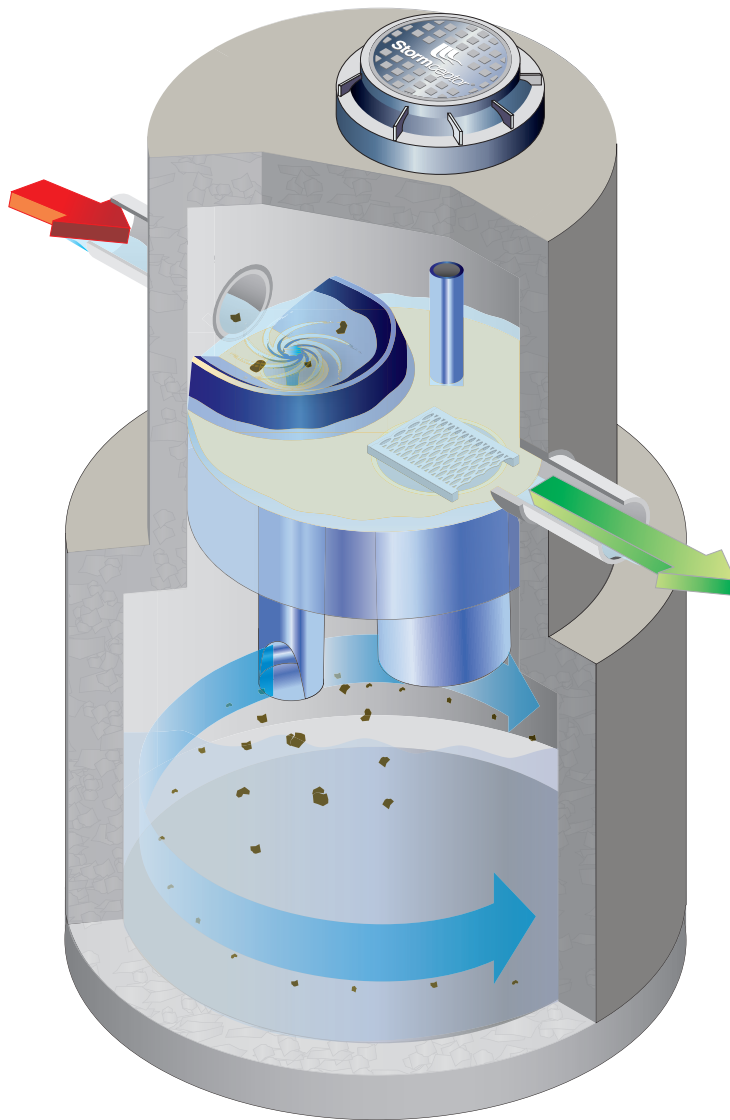

Stormceptor is protected by one or more of the following patents:

Canadian Patent No. 2,137,942  
Canadian Patent No. 2,175,277  
Canadian Patent No. 2,180,305  
Canadian Patent No. 2,180,338  
Canadian Patent No. 2,206,338  
Canadian Patent No. 2,327,768  
U.S. Patent No. 5,753,115  
U.S. Patent No. 5,849,181  
U.S. Patent No. 6,068,765  
U.S. Patent No. 6,371,690  
U.S. Patent No. 7,582,216  
U.S. Patent No. 7,666,303  
Australia Patent No. 693.164  
Australia Patent No. 707,133  
Australia Patent No. 729,096  
Australia Patent No. 779,401  
Australia Patent No. 2008,279,378  
Australia Patent No. 2008,288,900  
Indonesia Patent No. 0007058  
Japan Patent No. 3581233  
Japan Patent No. 9-11476  
Korean Patent No. 0519212  
Malaysia Patent No. 118987  
New Zealand Patent No. 314,646  
New Zealand Patent No. 583,008  
New Zealand Patent No. 583,583  
South African Patent No. 2010/00682  
South African Patent No. 2010/01796  
Other Patents Pending

## **Table of Contents**

1 – Stormceptor Overview

2 – Stormceptor Operation & Components

3 – Stormceptor Identification

4 – Stormceptor Inspection & Maintenance

    Recommended Stormceptor Inspection Procedure

    Recommended Stormceptor Maintenance Procedure

5 – Contact Information (Stormceptor Licensees)

Congratulations!

Your selection of a Stormceptor® means that you have chosen the most recognized and efficient stormwater oil/sediment separator available for protecting the environment. Stormceptor is a pollution control device often referred to as a “Hydrodynamic Separator (HDS)” or an “Oil Grit Separator (OGS)”, engineered to remove and retain pollutants from stormwater runoff to protect our lakes, rivers and streams from the harmful effects of non-point source pollution.

## 1 – Stormceptor Overview

Stormceptor is a patented stormwater quality structure most often utilized as a treatment component of the underground storm drain network for stormwater pollution prevention. Stormceptor is designed to remove sediment, total suspended solids (TSS), other pollutants attached to sediment, hydrocarbons and free oil from stormwater runoff. Collectively the Stormceptor provides spill protection and prevents non-point source pollution from entering downstream waterways.

### Key benefits of Stormceptor include:

- Removes sediment, suspended solids, debris, nutrients, heavy metals, and hydrocarbons (oil and grease) from runoff and snowmelt.
- Will not scour or re-suspend trapped pollutants.
- Provides sediment and oil storage.
- Provides spill control for accidents, commercial and industrial developments.
- Easy to inspect and maintain (vacuum truck).
- “STORMCEPTOR” is *clearly* marked on the access cover (excluding inlet designs).
- Relatively small footprint.
- 3<sup>rd</sup> Party tested and independently verified.
- Dedicated team of experts available to provide support.

### Model Types:

- STC (Standard)
- STF (Fiberglass)
- EOS (Extended Oil Storage)
- OSR (Oil and Sand Removal)
- MAX (Custom designed unit, specific to site)

### Configuration Types:

- Inlet unit (accommodates inlet flow entry, and multi-pipe entry)
- In-Line (accommodates multi-pipe entry)
- Submerged Unit (accommodates the site’s tailwater conditions)
- Series Unit (combines treatment in two systems)

## **Please Maintain Your Stormceptor**

To ensure long-term environmental protection through continued performance as originally designed for your site, **Stormceptor must be maintained**, as any stormwater treatment practice does. The need for maintenance is determined through inspection of the Stormceptor. Procedures for inspection are provided within this document. Maintenance of the Stormceptor is performed from the surface via vacuum truck.

If you require information about Stormceptor, or assistance in finding resources to facilitate inspections or maintenance of your Stormceptor please call your local Stormceptor Licensee or Imbrium® Systems.

## **2 – Stormceptor Operation & Components**

Stormceptor is a flexibly designed underground stormwater quality treatment device that is unparalleled in its effectiveness for pollutant capture and retention using patented flow separation technology.

Stormceptor creates a non-turbulent treatment environment below the insert platform within the system. The insert diverts water into the lower chamber, allowing free oils and debris to rise, and sediment to settle under relatively low velocity conditions. These pollutants are trapped and stored below the insert and protected from large runoff events for later removal during the maintenance procedure.

With thousands of units operating worldwide, Stormceptor delivers reliable protection every day, in every storm. The patented Stormceptor design prohibits the scour and release of captured pollutants, ensuring superior water quality treatment and protection during even the most extreme storm events. Stormceptor's proven performance is backed by the longest record of lab and field verification in the industry.

## Stormceptor Schematic and Component Functions

Below are schematics of two common Stormceptor configurations with key components identified and their functions briefly described.

Figure 1.

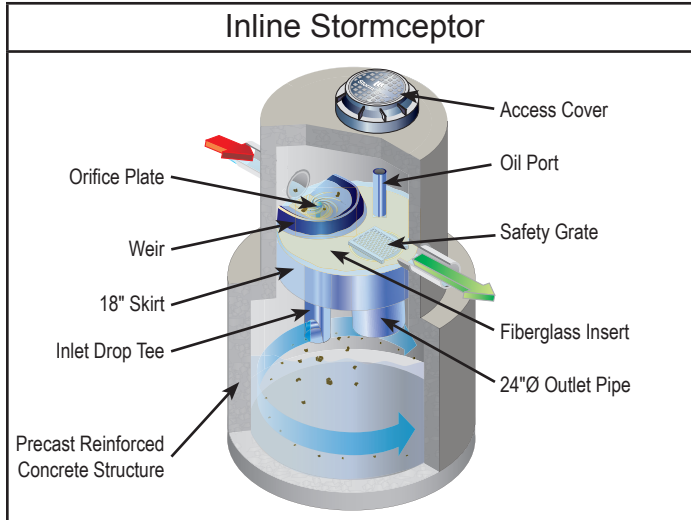
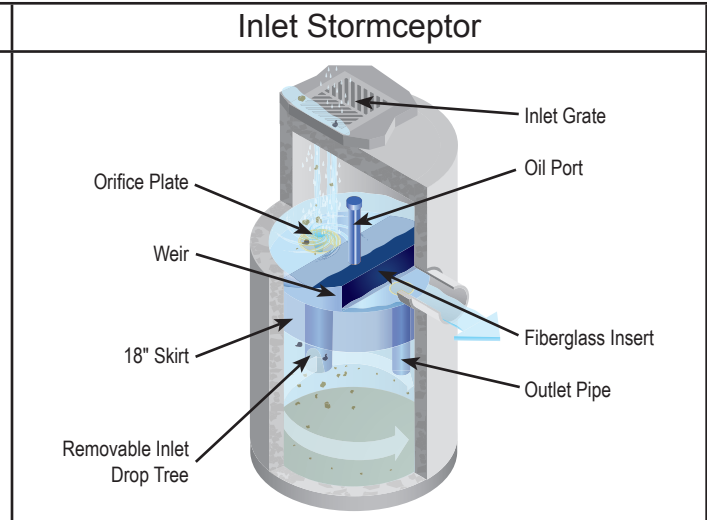

Figure 2.



- **Manhole access cover** – provides access to the subsurface components
- **Precast reinforced concrete structure** – provides the vessel's watertight structural support
- **Fiberglass insert** – separates vessel into upper and lower chambers
- **Weir** – directs incoming stormwater and oil spills into the lower chamber
- **Orifice plate** – prevents scour of accumulated pollutants
- **Inlet drop tee** – conveys stormwater into the lower chamber
- **Fiberglass skirt** – provides double-wall containment of hydrocarbons
- **Outlet riser pipe** – conveys treated water to the upper chamber; primary vacuum line access port for sediment removal
- **Oil inspection port** – primary access for measuring oil depth and oil removal
- **Safety grate** – safety measure to cover riser pipe in the event of manned entry into vessel

### 3 – Stormceptor Identification

Stormceptor is available in both precast concrete and fiberglass vessels, with precast concrete often being the dominant material of construction.

In the Stormceptor, a patented, engineered fiberglass insert separates the structure into an upper chamber and lower chamber. The lower chamber will remain full of water, as this is where the pollutants are sequestered for later removal. Multiple Stormceptor model (STC, OSR, EOS, MAX and STF) configurations exist, each to be inspected and maintained in a similar fashion.

Each unit is easily identifiable as a Stormceptor by the trade name “Stormceptor” embossed on each access cover at the surface. To determine the location of “inlet” Stormceptor units with horizontal catch basin inlet, look down into the grate as the Stormceptor insert will be visible. The name “Stormceptor” is not embossed on inlet models due to the variability of inlet grates used/ approved across North America.

Once the location of the Stormceptor is determined, the model number may be identified by comparing the measured depth from the fiberglass insert level at the outlet pipe's invert (water level) to the bottom of the tank using **Table 1**.

In addition, starting in 1996 a metal serial number tag containing the model number has been affixed to the inside of the unit, on the fiberglass insert. If the unit does not have a serial number, or if there is any uncertainty regarding the size of the unit using depth measurements, please contact your local Stormceptor Representative for assistance.

**Sizes/Models**

Typical general dimensions and capacities of the standard precast STC, EOS & OSR Stormceptor models in both USA and Canada/International (excluding South East Asia and Australia) are provided in **Tables 1 and 2**. Typical rim to invert measurements are provided later in this document. The total depth for cleaning will be the sum of the depth from outlet pipe invert (generally the water level) to rim (grade) and the depth from outlet pipe invert to the precast bottom of the unit. Note that depths and capacities may vary slightly between regions.

**Table 1A. (US) Stormceptor Dimensions – Insert to Base of Structure**

STC Model	Insert to Base (in.)	EOS Model	Insert to Base (in.)	OSR Model	Insert to Base (in.)	Typical STF m (in.)
450	60	4-175	60	65	60	1.5 (60)
900	55	9-365	55	140	55	1.5 (61)
1200	71	12-590	71			1.8 (73)
1800	105	18-1000	105			2.9 (115)
2400	94	24-1400	94	250	94	2.3 (89)
3600	134	36-1700	134			3.2 (127)
4800	128	48-2000	128	390	128	2.9 (113)
6000	150	60-2500	150			3.5 (138)
7200	134	72-3400	134	560	134	3.3 (128)
11000*	128	110-5000*	128	780*	128	
13000*	150	130-6000*	150			
16000*	134	160-7800*	134	1125*	134	

**Notes:**

1. Depth Below Pipe Inlet Invert to the Bottom of Base Slab can vary slightly by manufacturing facility, and can be modified to accommodate specific site designs, pollutant loads or site conditions. Contact your local representative for assistance.

\*Consist of two chamber structures in series.

**Table 1B. (CA & Int'l) Stormceptor Dimensions – Insert to Base of Structure**

STC Model	Insert to Base (m)	EOS Model	Insert to Base (m)	OSR Model	Insert to Base (m)	Typical STF m (in.)
300	1.5	300	1.5	300	1.7	1.5 (60)
750	1.5	750	1.5	750	1.6	1.5 (61)
1000	1.8	1000	1.8			1.8 (73)
1500	2.8					2.9 (115)
2000	2.8	2000	2.8	2000	2.6	2.3 (89)
3000	3.7	3000	3.7			3.2 (127)
4000	3.4	4000	3.4	4000	3.6	2.9 (113)
5000	4.0	5000	4.0			3.5 (138)
6000	3.7	6000	3.7	6000	3.7	3.3 (128)
9000*	3.4	9000*	3.4	9000*	3.6	
11000*	4.0	10000*	4.0			
14000*	3.7	14000*	3.7	14000*	3.7	

**Notes:**

1. Depth Below Pipe Inlet Invert to the Bottom of Base Slab can vary slightly by manufacturing facility, and can be modified to accommodate specific site designs, pollutant loads or site conditions. Contact your local representative for assistance.

*\*Consist of two chamber structures in series.*

**Table 2A. (US) Storage Capacities**

STC Model	Hydrocarbon Storage Capacity gal	Sediment Capacity ft <sup>3</sup>	EOS Model	Hydrocarbon Storage Capacity gal	OSR Model	Hydrocarbon Storage Capacity gal	Sediment Capacity ft <sup>3</sup>
<b>450</b>	86	46	<b>4-175</b>	175	<b>065</b>	115	46
<b>900</b>	251	89	<b>9-365</b>	365	<b>140</b>	233	58
<b>1200</b>	251	127	<b>12-590</b>	591			
<b>1800</b>	251	207	<b>18-1000</b>	1198			
<b>2400</b>	840	205	<b>24-1400</b>	1457	<b>250</b>	792	156
<b>3600</b>	840	373	<b>36-1700</b>	1773			
<b>4800</b>	909	543	<b>48-2000</b>	2005	<b>390</b>	1233	465
<b>6000</b>	909	687	<b>60-2500</b>	2514			
<b>7200</b>	1059	839	<b>72-3400</b>	3418	<b>560</b>	1384	690
<b>11000*</b>	2797	1089	<b>110-5000*</b>	5023	<b>780*</b>	2430	930
<b>13000*</b>	2797	1374	<b>130-6000*</b>	6041			
<b>16000*</b>	3055	1677	<b>160-7800*</b>	7850	<b>1125*</b>	2689	1378

**Notes:**

1. Hydrocarbon & Sediment capacities can be modified to accommodate specific site design requirements, contact your local representative for assistance.

*\*Consist of two chamber structures in series.*

**Table 2B. (CA & Int'l) Storage Capacities**

STC Model	Hydrocarbon Storage Capacity	Sediment Capacity	EOS Model	Hydrocarbon Storage Capacity	OSR Model	Hydrocarbon Storage Capacity	Sediment Capacity
	L	L		L		L	L
<b>300</b>	300	1450	<b>300</b>	662	<b>300</b>	300	1500
<b>750</b>	915	3000	<b>750</b>	1380	<b>750</b>	900	3000
<b>1000</b>	915	3800	<b>1000</b>	2235			
<b>1500</b>	915	6205					
<b>2000</b>	2890	7700	<b>2000</b>	5515	<b>2000</b>	2790	7700
<b>3000</b>	2890	11965	<b>3000</b>	6710			
<b>4000</b>	3360	16490	<b>4000</b>	7585	<b>4000</b>	4700	22200
<b>5000</b>	3360	20940	<b>5000</b>	9515			
<b>6000</b>	3930	26945	<b>6000</b>	12940	<b>6000</b>	5200	26900
<b>9000*</b>	10555	32980	<b>9000*</b>	19010	<b>9000*</b>	9300	33000
<b>11000*</b>	10555	37415	<b>10000*</b>	22865			
<b>14000*</b>	11700	53890	<b>14000*</b>	29715	<b>14000*</b>	10500	53900

*Notes:*

1. Hydrocarbon & Sediment capacities can be modified to accommodate specific site design requirements, contact your local representative for assistance.

*\*Consist of two chamber structures in series.*

## 4 – Stormceptor Inspection & Maintenance

Regular inspection and maintenance is a proven, cost-effective way to maximize water resource protection for all stormwater pollution control practices, and is required to insure proper functioning of the Stormceptor. Both inspection and maintenance of the Stormceptor is easily performed from the surface. Stormceptor’s patented technology has no moving parts, simplifying the inspection and maintenance process.

Please refer to the following information and guidelines before conducting inspection and maintenance activities.

### ***When is inspection needed?***

- Post-construction inspection is required prior to putting the Stormceptor into service.
- Routine inspections are recommended during the first year of operation to accurately assess the sediment accumulation.
- Inspection frequency in subsequent years is based on the maintenance plan developed in the first year.
- Inspections should also be performed immediately after oil, fuel, or other chemical spills.

### ***When is maintenance cleaning needed?***

- For optimum performance, the unit should be cleaned out once the sediment depth reaches the recommended maintenance sediment depth, which is approximately 15% of the unit’s total storage capacity (see **Table 2**). The frequency should be adjusted based on historical inspection results due to variable site pollutant loading.

- Sediment removal is easier when removed on a regular basis at or prior to the recommended maintenance sediment depths, as sediment build-up can compact making removal more difficult.
- The unit should be cleaned out immediately after an oil, fuel or chemical spill.

### ***What conditions can compromise Stormceptor performance?***

- If construction sediment and debris is not removed prior to activating the Stormceptor unit, maintenance frequency may be reduced.
- If the system is not maintained regularly and fills with sediment and debris beyond the capacity as indicated in **Table 2**, pollutant removal efficiency may be reduced.
- If an oil spill(s) exceeds the oil capacity of the system, subsequent spills may not be captured.
- If debris clogs the inlet of the system, removal efficiency of sediment and hydrocarbons may be reduced.
- If a downstream blockage occurs, a backwater condition may occur for the Stormceptor and removal efficiency of sediment and hydrocarbons may be reduced.

### ***What training is required?***

The Stormceptor is to be inspected and maintained by professional vacuum cleaning service providers with experience in the maintenance of underground tanks, sewers and catch basins. For typical inspection and maintenance activities, no specific supplemental training is required for the Stormceptor. Information provided within this Manual (provided to the site owner) contains sufficient guidance to maintain the system properly.

In unusual circumstances, such as if a damaged component needs replacement or some other condition requires manned entry into the vessel, confined space entry procedures must be followed. Only professional maintenance service providers trained in these procedures should enter the vessel. Service provider companies typically have personnel who are trained and certified in confined space entry procedures according to local, state, and federal standards.

### ***What equipment is typically required for inspection?***

- Manhole access cover lifting tool
- Oil dipstick / Sediment probe with ball valve (typically ¾-inch to 1-inch diameter)
- Flashlight
- Camera
- Data log / Inspection Report
- Safety cones and caution tape
- Hard hat, safety shoes, safety glasses, and chemical-resistant gloves

## Recommended Stormceptor Inspection Procedure:

- Stormceptor is to be inspected from grade through a standard surface manhole access cover.
- Sediment and oil depth inspections are performed with a sediment probe and oil dipstick.
- Oil depth is measured through the oil inspection port, either a 4-inch (100 mm) or 6-inch (150 mm) diameter port.
- Sediment depth can be measured through the oil inspection port or the 24-inch (610 mm) diameter outlet riser pipe.
- Inspections also involve a visual inspection of the internal components of the system.

Figure 3.

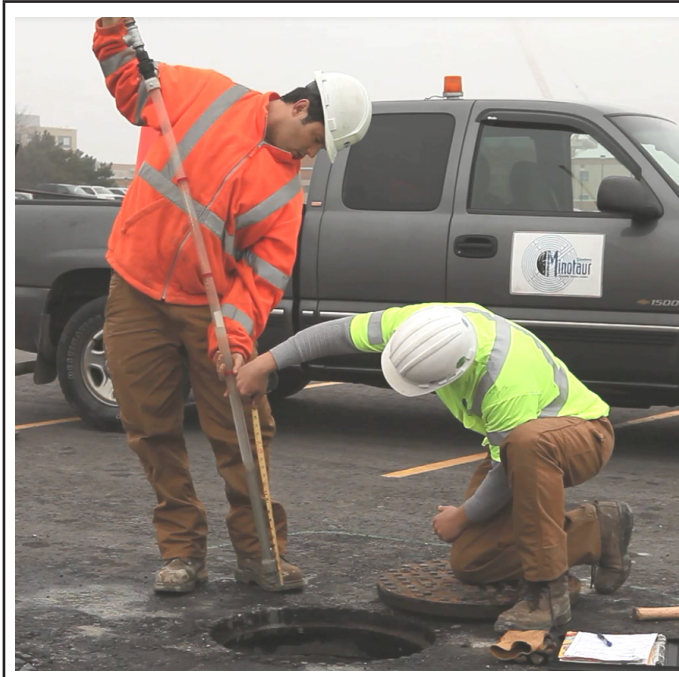
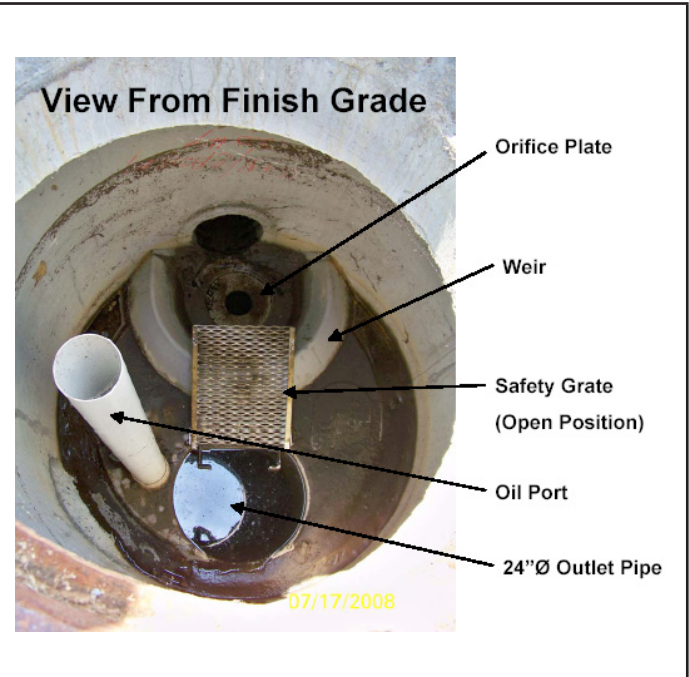

Figure 4.



## What equipment is typically required for maintenance?

- Vacuum truck equipped with water hose and jet nozzle
- Small pump and tubing for oil removal
- Manhole access cover lifting tool
- Oil dipstick / Sediment probe with ball valve (typically 3/4-inch to 1-inch diameter)
- Flashlight
- Camera
- Data log / Inspection Report
- Safety cones
- Hard hats, safety shoes, safety glasses, chemical-resistant gloves, and hearing protection for service providers
- Gas analyzer, respiratory gear, and safety harness for specially trained personnel if confined space entry is required

## Recommended Stormceptor Maintenance Procedure

Maintenance of Stormceptor is performed using a vacuum truck.

No entry into the unit is required for maintenance. **DO NOT ENTER THE STORMCEPTOR CHAMBER** unless you have the proper personal safety equipment, have been trained and are qualified to enter a confined space, as identified by local Occupational Safety and Health Regulations (e.g. 29 CFR 1910.146 or Canada Occupational Safety and Health Regulations – SOR/86-304). Without the proper equipment, training and permit, entry into confined spaces can result in serious bodily harm and potentially death. Consult local, provincial, and/or state regulations to determine the requirements for confined space entry. Be aware, and take precaution that the Stormceptor fiberglass insert may be slippery. In addition, be aware that some units do not have a safety grate to cover the outlet riser pipe that leads to the submerged, lower chamber.

- Ideally maintenance should be conducted during dry weather conditions when no flow is entering the unit.
- Stormceptor is to be maintained through a standard surface manhole access cover.
- Insert the oil dipstick into the oil inspection port. If oil is present, pump off the oil layer into separate containment using a small pump and tubing.
- Maintenance cleaning of accumulated sediment is performed with a vacuum truck.
  - For 6-ft (1800 mm) diameter models and larger, the vacuum hose is inserted into the lower chamber via the 24-inch (610 mm) outlet riser pipe.
  - For 4-ft (1200 mm) diameter model, the removable drop tee is lifted out, and the vacuum hose is inserted into the lower chamber via the 12-inch (305 mm) drop tee hole.

Figure 5.

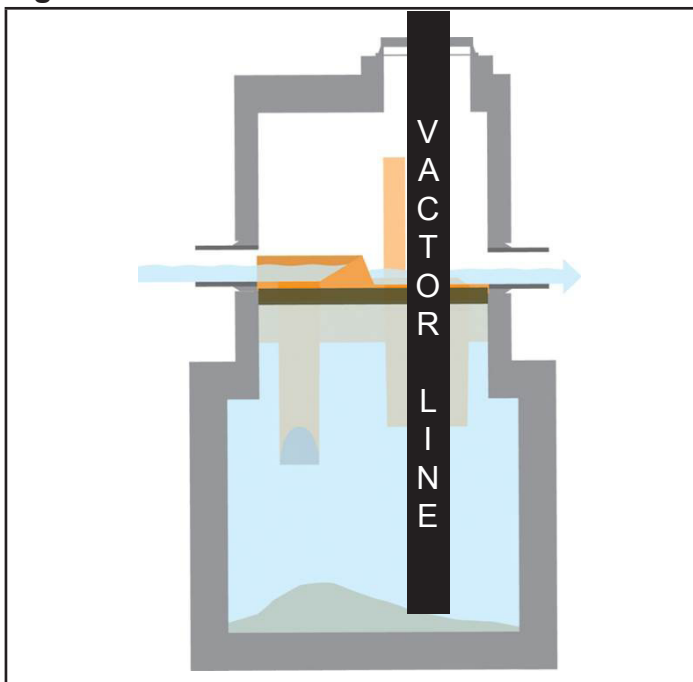
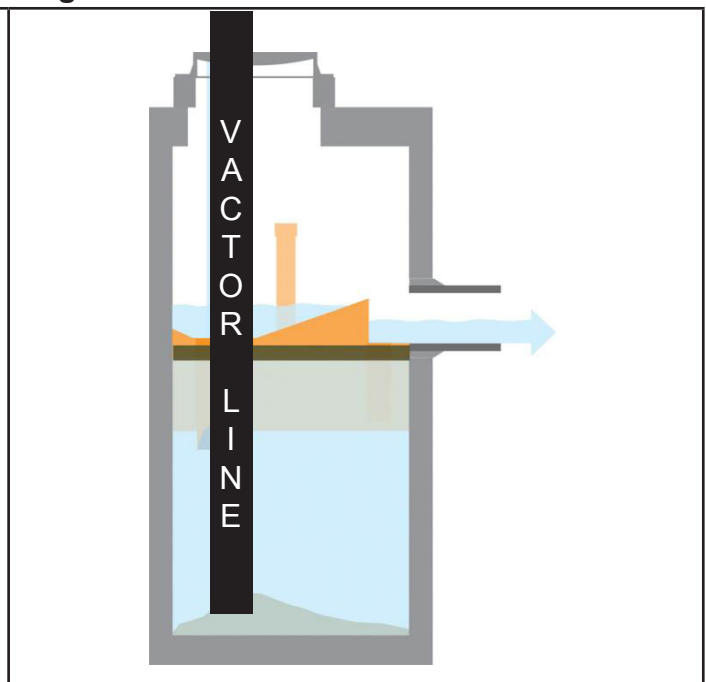

Figure 6.



- Using the vacuum hose, decant the water from the lower chamber into a separate containment tank or to the sanitary sewer, if permitted by the local regulating authority.
- Remove the sediment sludge from the bottom of the unit using the vacuum hose. For large Stormceptor units, a flexible hose is often connected to the primary vacuum line for ease of movement in the lower chamber.
- Units that have not been maintained regularly, have surpassed the maximum recommended sediment capacity, or contain damaged components may require manned entry by trained personnel using safe and proper confined space entry procedures.

**Figure 7.**



**Figure 8.**



*A maintenance worker stationed at the above ground surface uses a vacuum hose to evacuate water, sediment, and debris from the system.*

### ***What is required for proper disposal?***

The requirements for the disposal of material removed from Stormceptor units are similar to that of any other stormwater treatment Best Management Practices (BMP). Local guidelines should be consulted prior to disposal of the separator contents. In most areas the sediment, once dewatered, can be disposed of in a sanitary landfill. It is not anticipated that the sediment would be classified as hazardous waste. This could be site and pollutant dependent. In some cases, approval from the disposal facility operator/agency may be required.

### ***What about oil spills?***

Stormceptor is often implemented in areas where there is high potential for oil, fuel or other hydrocarbon or chemical spills. Stormceptor units should be cleaned immediately after a spill occurs by a licensed liquid waste hauler. You should also notify the appropriate regulatory agencies as required in the event of a spill.

### ***What if I see an oil rainbow or sheen at the Stormceptor outlet?***

With a steady influx of water with high concentrations of oil, a sheen may be noticeable at the Stormceptor outlet. This may occur because a hydrocarbon rainbow or sheen can be seen at

very small oil concentrations (< 10 ppm). Stormceptor is effective at removing 95% of free oil, and the appearance of a sheen at the outlet with high influent oil concentrations does not mean that the unit is not working to this level of removal. In addition, if the influent oil is emulsified, the Stormceptor will not be able to remove it. The Stormceptor is designed for free oil removal and not emulsified or dissolved oil conditions.

**What factors affect the costs involved with inspection/maintenance?**

The Vacuum Service Industry for stormwater drainage and sewer systems is a well-established sector of the service industry that cleans underground tanks, sewers and catch basins. Costs to clean Stormceptor units will vary. Inspection and maintenance costs are most often based on unit size, the number of units on a site, sediment/oil/hazardous material loads, transportation distances, tipping fees, disposal requirements and other local regulations.

**What factors predict maintenance frequency?**

Maintenance frequency will vary with the amount of pollution on your site (number of hydrocarbon spills, amount of sediment, site activity and use, etc.). It is recommended that the frequency of maintenance be increased or reduced based on local conditions. If the sediment load is high from an unstable site or sediment loads transported from upstream catchments, maintenance may be required semi-annually. Conversely once a site has stabilized, maintenance may be required less frequently (for example: two to seven year, site and situation dependent). Maintenance should be performed immediately after an oil spill or once the sediment depth in Stormceptor reaches the value specified in **Table 3** based on the unit size.

**Table 3A. (US) Recommended Sediment Depths Indicating Maintenance**

STC Model	Maintenance Sediment depth (in)	EOS Model	Maintenance Sediment depth (in)	Oil Storage Depth (in)	OSR Model	Maintenance Sediment depth (in)
450	8	4-175	9	24	065	8
900	8	9-365	9	24	140	8
1200	10	12-590	11	39		
1800	15					
2400	12	24-1400	14	68	250	12
3600	17	36-1700	19	79		
4800	15	48-2000	16	68	390	17
6000	18	60-2500	20	79		
7200	15	72-3400	17	79	560	17
11000*	17	110-5000*	16	68	780*	17
13000*	20	130-6000*	20	79		
16000*	17	160-7800*	17	79	1125*	17

Note:

1. The values above are for typical standard units.

\*Per structure.

**Table 3B. (CA & Int'l) Recommended Sediment Depths Indicating Maintenance**

STC Model	Maintenance Sediment depth (mm)	EOS Model	Maintenance Sediment depth (mm)	Oil Storage Depth (mm)	OSR Model	Maintenance Sediment depth (mm)
300	225	300	225	610	300	200
750	230	750	230	610	750	200
1000	275	1000	275	990		
1500	400					
2000	350	2000	350	1727	2000	300
3000	475	3000	475	2006		
4000	400	4000	400	1727	4000	375
5000	500	5000	500	2006		
6000	425	6000	425	2006	6000	375
9000*	400	9000*	400	1727	9000*	425
11000*	500	10000*	500	2006		
14000*	425	14000*	425	2006	14000*	425

Note:

1. The values above are for typical standard units.

\*Per structure.

### **Replacement parts**

Since there are no moving parts during operation in a Stormceptor, broken, damaged, or worn parts are not typically encountered. Therefore, inspection and maintenance activities are generally focused on pollutant removal. However, if replacements parts are necessary, they may be purchased by contacting your local Stormceptor Representative, or Imbrium Systems.

**The benefits of regular inspection and maintenance are many – from ensuring maximum operation efficiency, to keeping maintenance costs low, to the continued protection of natural waterways – and provide the key to Stormceptor’s long and effective service life.**

### **Stormceptor Inspection and Maintenance Log**

Stormceptor Model No: \_\_\_\_\_

Allowable Sediment Depth: \_\_\_\_\_

Serial Number: \_\_\_\_\_

Installation Date: \_\_\_\_\_

Location Description of Unit: \_\_\_\_\_

Other Comments: \_\_\_\_\_

## **Contact Information**

Questions regarding the Stormceptor can be addressed by contacting your area Stormceptor Licensee, Imbrium Systems, or visit our website at [www.stormceptor.com](http://www.stormceptor.com).

### **Stormceptor Licensees:**

#### **CANADA**

Lafarge Canada Inc.  
[www.lafargepipe.com](http://www.lafargepipe.com)  
403-292-9502 / 1-888-422-4022  
780-468-5910  
204-958-6348

Calgary, AB  
Edmonton, AB  
Winnipeg, MB, NW. ON, SK

Langley Concrete Group  
[www.langleyconcretigroup.com](http://www.langleyconcretigroup.com)  
604-502-5236

BC

Hanson Pipe & Precast Inc.  
[www.hansonpipeandprecast.com](http://www.hansonpipeandprecast.com)  
519-622-7574 / 1-888-888-3222

ON

Lécuyer et Fils Ltée.  
[www.lecuyerbeton.com](http://www.lecuyerbeton.com)  
450-454-3928 / 1-800-561-0970

QC

Strescon Limited  
[www.strescon.com](http://www.strescon.com)  
902-494-7400  
506-633-8877

NS, NF  
NB, PE

#### **UNITED STATES**

Rinker Materials  
[www.rinkerstormceptor.com](http://www.rinkerstormceptor.com)  
1-800-909-7763

#### **AUSTRALIA & SOUTHEAST ASIA, including New Zealand & Japan**

Humes Water Solutions  
[www.humes.com.au](http://www.humes.com.au)  
+61 7 3364 2894

#### **Imbrium Systems Inc. & Imbrium Systems LLC**

Canada 1-416-960-9900 / 1-800-565-4801  
United States 1-301-279-8827 / 1-888-279-8826  
International +1-416-960-9900 / +1-301-279-8827  
Email [info@imbriumsystems.com](mailto:info@imbriumsystems.com)

[www.imbriumsystems.com](http://www.imbriumsystems.com)  
[www.stormceptor.com](http://www.stormceptor.com)

**From:** Ryan Good <[r.good@novatech-eng.com](mailto:r.good@novatech-eng.com)>

**Sent:** Tuesday, September 16, 2025 3:38 PM

**To:** Brandon O'Leary <[brandon.oleary@RinkerPipe.com](mailto:brandon.oleary@RinkerPipe.com)>

**Cc:** Anthony Mestwarp <[a.mestwarp@novatech-eng.com](mailto:a.mestwarp@novatech-eng.com)>; Greg MacDonald <[g.Macdonald@novatech-eng.com](mailto:g.Macdonald@novatech-eng.com)>; Mike Petepiece <[m.petepiece@novatech-eng.com](mailto:m.petepiece@novatech-eng.com)>

**Subject:** RE: [EXTERNAL] 541 Somme Street - OGS Unit - (124111)

Hi Brandon,

Regarding the EFO4 Stormceptor, is backflow of stormwater during storm events a concern? One City comment we received was to provide a backflow prevention device for when the ditch fronting the site surcharges above the outlet (which will occur in the 10yr + storm events).

If backflow is a concern which will affect performance, we can specify a flap gate at the outlet. If it is not a concern for the unit's performance, we will respond accordingly to the City.

Thanks,

**Ryan Good**, C.E.T., Design Technologist | Land Development and Public Sector Infrastructure

**NOVATECH**

Engineers, Planners & Landscape Architects

240 Michael Cowpland Drive, Suite 200, Ottawa, ON, K2M 1P6 | Tel: 613.254.9643 Ext: 284 | Cell: 343-364-2246

The information contained in this email message is confidential and is for exclusive use of the addressee.

**From:** Brandon O'Leary <[brandon.oleary@RinkerPipe.com](mailto:brandon.oleary@RinkerPipe.com)>  
**Sent:** Tuesday, September 16, 2025 3:30 PM  
**To:** Ryan Good <[r.good@novatech-eng.com](mailto:r.good@novatech-eng.com)>  
**Cc:** Anthony Mestwarp <[a.mestwarp@novatech-eng.com](mailto:a.mestwarp@novatech-eng.com)>; Greg MacDonald <[g.Macdonald@novatech-eng.com](mailto:g.Macdonald@novatech-eng.com)>; Mike Petepiece <[m.petepiece@novatech-eng.com](mailto:m.petepiece@novatech-eng.com)>  
**Subject:** RE: [EXTERNAL] 541 Somme Street - OGS Unit - (124111)

Hello Ryan,

Backwater for the 10-year event is not an issue for the performance of the unit as the unit would be bypassing internally during this event anyway.

Best Regards,

Brandon O'Leary, P.Eng., B.A.Sc.  
Stormwater Specialist  
Bowmanville/Cambridge Plant  
Cell: (905) 630-0359



We are excited to announce that Forterra is now Rinker Materials

***Stormceptor***

*Protecting the water for future generations*

*Our Online Sizing Tool for the Stormceptor EFO:*

<https://www.imbriumsystems.com/login?returnurl=%2flaunch-pcswmm-for-stormceptor>

**From:** Ryan Good <[r.good@novatech-eng.com](mailto:r.good@novatech-eng.com)>

**Sent:** Wednesday, December 10, 2025 12:21 PM

**To:** Brandon O'Leary <[brandon.oleary@RinkerPipe.com](mailto:brandon.oleary@RinkerPipe.com)>

**Cc:** Anthony Mestwarp <[a.mestwarp@novatech-eng.com](mailto:a.mestwarp@novatech-eng.com)>; Greg MacDonald <[g.Macdonald@novatech-eng.com](mailto:g.Macdonald@novatech-eng.com)>; Mike Petepiece <[m.petepiece@novatech-eng.com](mailto:m.petepiece@novatech-eng.com)>; Anjush Musyaju <[a.musyaju@novatech-eng.com](mailto:a.musyaju@novatech-eng.com)>

**Subject:** RE: [EXTERNAL] 541 Somme Street - OGS Unit - (124111)

Hi Brandon, thanks for the response below regarding the backflow and OGS impact at 541 Somme Street. After further evaluation on our end it appears the 5yr and the 2yr event, in the ditch where we outlet, will be above the outlet's invert. The 5 yr event will be above the overflow weir (the 2yr will not be). Can you please confirm if this is a concern or does the same principle apply?

We have received comments from the City on our latest submission. I have included copies of the comments below (in blue) that relate to our SWM outlet and the OGS unit. These comments are related to the details I noted above, can you please provide input from Rinker's perspective to the impact/operation of the storm event water levels and the OGS? I have attached a copy of our Notes and Details plan as well, please see section E-E for the outlet location.

- Table 5.4-B (Somme Street Ditch-Design Flow and Water Levels Table) sets the 2-year return water elevation in the municipal ditch at 88.23 m (up to 88.54 for a 100-year), while the OGS outlet is at 87.97 m, which indicates that the ditch stormwater will likely backflow into the OGS, and upstream of it, frequently and the OGS will not operate as designed. Please also see the related comment, under the "Notes and Details Plan (124111-ND)" section and contemplate a viable solution.
- Given the provided, 2-year to 100-year return periods, with ditch water levels elevations (88.23 m to 88.54 m), it is evident that, with the site SWM outlet invert elevation of 87.95 m and the OGS outlet invert of 87.97 m, the ditch stormwater will be backflowing into the OGS, under less than 2-year return period condition. Also, under a 5-year return flow condition, the stormwater will overflow the top of the OGS overflow weir and backflow beyond the OGS inlet. This condition will lead to backflow of sedimentation from the ditch, into the outlet pipe and into the OGS itself, thereby likely defeating its intended function. The response to the last City comment, from Novatech, concerning this matter, stated that communication from Rinker Materials was attached, in the SWM report, and assured that this condition will not have an impact on the OGS operation. Such communication was not found in the stated report. The response from Rinker, if such is deemed satisfactory by the Civil engineer endorsing the SWM operations on-site, should be provided in the report, and it should be clear in the assertions of a proper OGS operation under the described conditions (anticipated backflow of water for majority of storm events), and it should also address the OGS servicing requirements, if they are anticipated to be different than the standard operating procedures.

Thank you,

**Ryan Good**, C.E.T., Design Technologist | Land Development and Public Sector Infrastructure

**NOVATECH**

Engineers, Planners & Landscape Architects

240 Michael Cowpland Drive, Suite 200, Ottawa, ON, K2M 1P6 | Tel: 613.254.9643 Ext: 284 | Cell: 343-364-2246

**From:** Brandon O'Leary <brandon.oleary@RinkerPipe.com>  
**Sent:** Wednesday, December 10, 2025 4:14 PM  
**To:** Ryan Good <r.good@novatech-eng.com>  
**Cc:** Anthony Mestwarp <a.mestwarp@novatech-eng.com>; Greg MacDonald <g.Macdonald@novatech-eng.com>; Mike Petepiece <m.petepiece@novatech-eng.com>  
**Subject:** RE: [EXTERNAL] 541 Somme Street - OGS Unit - (124111)

Hello Ryan,

I have reviewed the provided comments. The lower chamber treatment flow rate for the EFO4 is 10.4 L/s, which means that once the conveyed flow reaches 10.4 L/s, any excess flow will begin bypassing over the internal weir. Our general rule of thumb is that if there is no permanent tailwater conditions, then it would not be necessary to adjust the design as generally the lower chamber treatment flow is well below even the 2-year peak flow. The more exact answer would be that if no backwater occurs at the beginning of the water quality event until the conveyed flow is in excess of 10.4 L/s, then it would not impact the TSS removal calculations as it would not impact the average annual volume of runoff directed through the lower chamber. I am unsure if there would be a way for you to calculate if the backwater surface water elevation would be in excess of 87.97 m for flows at the beginning of the water quality event up to 10.4 L/s. If you can calculate, this, then it would demonstrate there would not be an issue during normal operation of the unit.

Other than the relocation of the unit, we can extend the height of the weir to compensate for backwater; however, we would only want to implement this design change if there is backwater prior to excess flow bypass as described above. An extended weir when there is no backwater in the unit can result in higher velocities going through the lower chamber than were tested during ETV scour testing, which could cause re-suspension of previously captured sediment.

I would also reference our third-party ETV test scour results, attached, that demonstrates the EFO has been designed to prevent this re-suspension for the standard design (our recommended scour limit is 10 mg/L, 25 mg/L is the MECP scour limit based on their standard CLI-ECA conditions).

Best Regards,

Brandon O'Leary, P.Eng., B.A.Sc.  
Stormwater Specialist  
Bowmanville/Cambridge Plant  
Cell: (905) 630-0359



**We are excited to announce that Forterra is now Rinker Materials**

***Stormceptor***

*Protecting the water for future generations*

*Our Online Sizing Tool for the Stormceptor EFO:*

<https://www.imbriumsystems.com/login?returnurl=%2flaunch-pcswmm-for-stormceptor>

**From:** Ryan Good <[r.good@novatech-eng.com](mailto:r.good@novatech-eng.com)>  
**Sent:** Tuesday, December 23, 2025 2:54 PM  
**To:** Brandon O'Leary <[brandon.oleary@RinkerPipe.com](mailto:brandon.oleary@RinkerPipe.com)>  
**Cc:** Anthony Mestwarp <[a.mestwarp@novatech-eng.com](mailto:a.mestwarp@novatech-eng.com)>; Greg MacDonald <[g.Macdonald@novatech-eng.com](mailto:g.Macdonald@novatech-eng.com)>; Mike Petepiece <[m.petepiece@novatech-eng.com](mailto:m.petepiece@novatech-eng.com)>; Anjush Musyaju <[a.musyaju@novatech-eng.com](mailto:a.musyaju@novatech-eng.com)>; Kent Campbell <[stanley.campbell@rinkerpipe.com](mailto:stanley.campbell@rinkerpipe.com)>; Jessica Steffler <[jessica.steffler@RinkerPipe.com](mailto:jessica.steffler@RinkerPipe.com)>; Miriam Epp <[Miriam.Epp@rinkerpipe.com](mailto:Miriam.Epp@rinkerpipe.com)>  
**Subject:** RE: [EXTERNAL] 541 Somme Street - OGS Unit - (124111)

Thanks Brandon, I provided you response below to Mike Petepiece (our lead SWM Engineer) and he will be assisting with the response to the City's latest SWM comments.

We also had a meeting with the City's Engineer (Derek Kulyk) to review comments and ensure we are moving forward with an approach they deemed adequate to prevent further comments. Regarding the OGS Unit, its treatment abilities, and the backflow concerns, Derrek indicated if the individual from Rinker was an Engineering Professional who was comfortable standing behind their response it would help the City accept the response. I informed Derek that you were an Engineer with your P.Eng designation; can you please confirm if you are comfortable standing behind your responses from a professional perspective (and if so, this correspondence will be included within the SWM report for support of the design).

Let me know if you need any further details or wish to discuss the information above.

Thanks,

**Ryan Good**, C.E.T., Design Technologist | Land Development and Public Sector Infrastructure

**NOVATECH**

Engineers, Planners & Landscape Architects

240 Michael Cowpland Drive, Suite 200, Ottawa, ON, K2M 1P6 | Tel: 613.254.9643 Ext: 284 | Cell: 343-364-2246

The information contained in this email message is confidential and is for exclusive use of the addressee.

**From:** Brandon O'Leary <brandon.oleary@RinkerPipe.com>  
**Sent:** Monday, January 5, 2026 3:05 PM  
**To:** Ryan Good <r.good@novatech-eng.com>  
**Cc:** Anthony Mestwarp <a.mestwarp@novatech-eng.com>; Greg MacDonald <g.Macdonald@novatech-eng.com>; Mike Petepiece <m.petepiece@novatech-eng.com>; Anjush Musyaju <a.musyaju@novatech-eng.com>; Kent Campbell <stanley.campbell@rinkerpipe.com>; Jessica Steffler <jessica.steffler@RinkerPipe.com>; Miriam Epp <Miriam.Epp@rinkerpipe.com>  
**Subject:** RE: [EXTERNAL] 541 Somme Street - OGS Unit - (124111)

Hello Ryan,

Happy New Year!

I can confirm that I am comfortable standing behind my response on December 10<sup>th</sup> in regards to the impact of backwater on the unit.

If you need anything else, please let me know.

Best Regards,

Brandon O'Leary, P.Eng., B.A.Sc.  
Stormwater Specialist  
Bowmanville/Cambridge Plant  
Cell: (905) 630-0359



We are excited to announce that Forterra is now Rinker Materials

***Stormceptor***

*Protecting the water for future generations*

*Our Online Sizing Tool for the Stormceptor EFO:*

<https://www.imbriumsystems.com/login?returnurl=%2flaunch-pcswmm-for-stormceptor>

541 Somme Street  
Entrance Culvert - Sizing Details

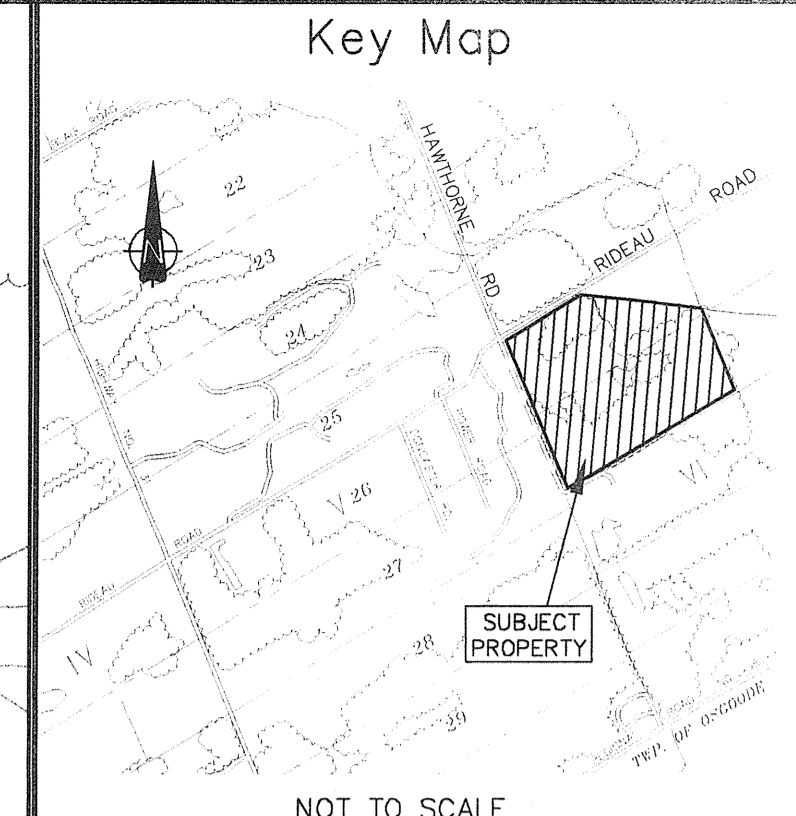
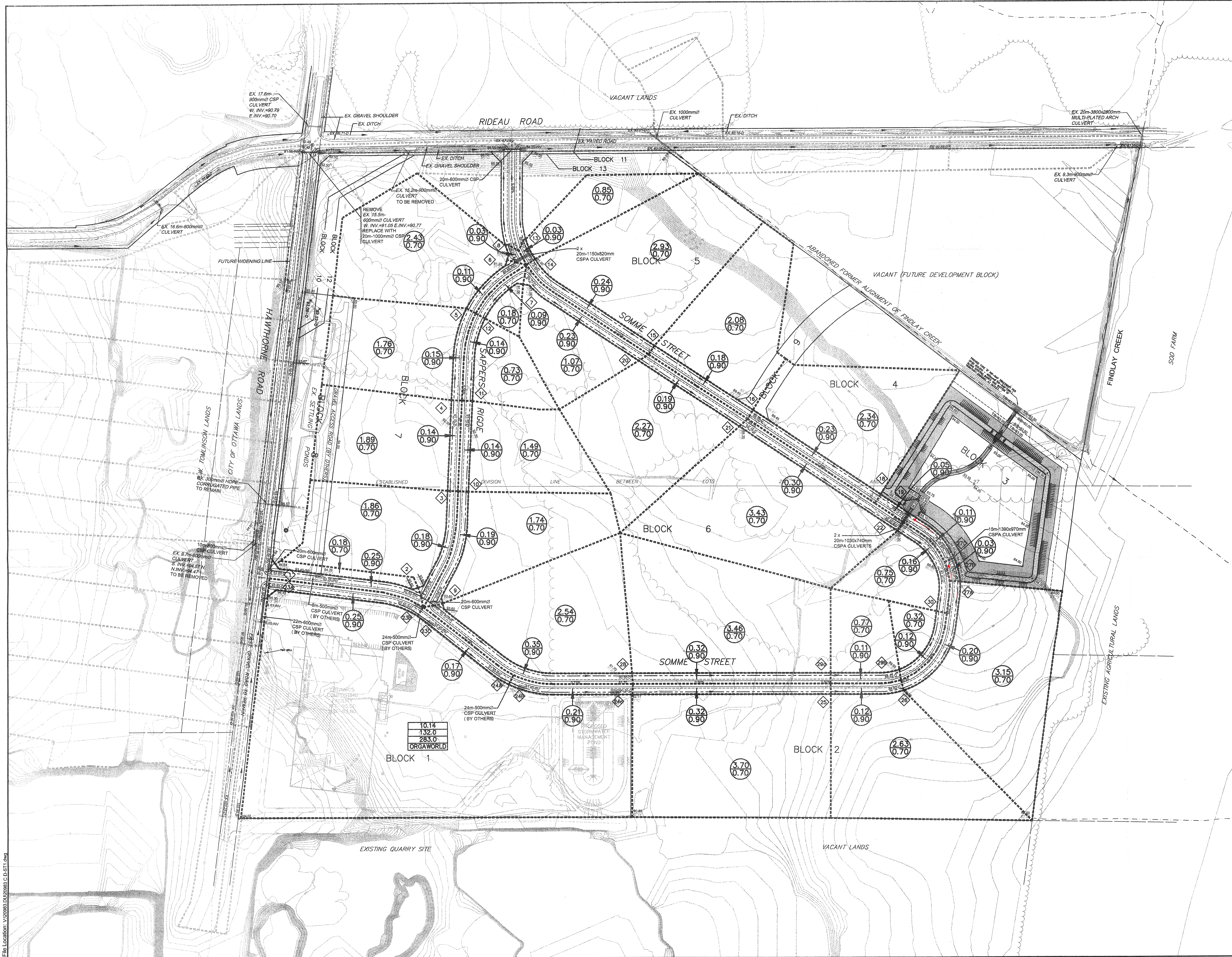

**LEGEND**

----- DRAINAGE BOUNDARY  
 (C) AREA IN HECTARES  
 \* RUNOFF COEFFICIENT (C)

10.14	DRAINAGE AREA (ha)
132.0	10 YEAR PEAK FLOW (l/s)
283.0	100 YEAR PEAK FLOW (l/s)
ORGAWORLD	ORGAWORLD SITE

28 NODE LOCATION NUMBER  
 -> PROPOSED DITCH AND FLOW DIRECTION

\* NOTE: RUNOFF COEFFICIENT (C) FOR DEVELOPMENT AREA IS BASED ON A WEIGHTED AVERAGE OF 0.70, WHILE ROADWAYS ARE 0.90.

NO.	ISSUE	DATE
03	ISSUED FOR M.O.E. APPROVAL	28/05/09
02	REVISED PER CITY COMMENTS	30/04/09
01	ISSUED FOR CITY APPROVAL	12/02/09

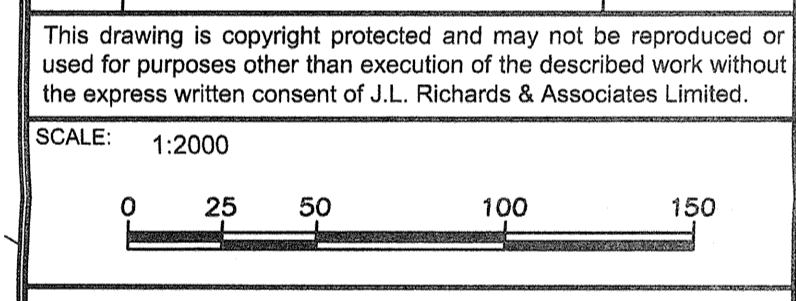

**J.L. Richards & Associates Limited**  
 203-863 Princess Street  
 Kingston, ON Canada  
 K7L 5N4  
 Tel: 613 544 1424  
 Fax: 613 544 5679

ENGINEERS ARCHITECTS-PLANNERS

PROFESSIONAL STAMP  
  
 D. P. UPTON  
 PROVINCE OF ONTARIO

PROJECT NORTH

PROJECT:  
**HAWTHORNE INDUSTRIAL PARK**

DRAWING:  
**STORM DRAINAGE AREA PLAN**

DESIGN: M.B.	DRAWING NO: <b>D-ST1</b>
DRAWN: T.S.	JLR NO:
CHECKED: D.U.	20983
PLOTTED: May 28, 2009	

Hawthorne Industrial Park

OPEN DITCH/CULVERT DESIGN SHEET

City of Ottawa

Prepared by: M. Buchanan, E.I.T.

JLR 20983

February 2009 (Revised April 2009)

Checked by: G. Forget, P.Eng.

1:10 year Ottawa International Airport IDF Curve

Increase Runoff Coefficient by 0.0%

DETAILS	NODES		DRAINAGE AREA					PEAK FLOW GENERATION					OPEN DITCH/SWALE DATA							CULVERTS SIZED UNDER 1:10 YEAR STORM EVENT					FLOW TIME (min)	U/S Inv (m)	D/S Inv (m)					
	FROM	TO	Area at C of		SUM(A)	SUM(A°C)	TOTAL A°C	2.78AR	2.78AR CUM	TIME min.	INTENS. mm/hr	PEAK FL. l/s	BW m	D <sub>10yr</sub> m	D <sub>max</sub> m	SS X:1	SLOPE %	Q <sub>10yr</sub> l/s	Q <sub>100yr</sub> l/s	VEL. m/s	LENGTH m	No. of Barrels	DIA (mm)	B x D (m)				INLET CONTROL	OUTLET CONTROL	HW 1:10 (m)		
<b>NORTHERN CATCHMENT AREA</b>																																
WEST SIDE SAPPERS RIDGE	2	3	1.86	0.18	2.04	1.46	1.46	4.07	4.07	15.00	97.85	398.2	0.00	0.42	1.20	3.00	0.50	424.2	6973.0	0.80	136.80								2.84	92.50	91.82	
WEST SIDE SAPPERS RIDGE	3	4	1.89	0.14	2.03	1.45	2.92	4.04	8.11	17.84	88.22	715.4	0.00	0.51	1.20	3.00	0.80	904.2	8856.1	1.16	111.00								1.60	91.82	90.93	
WEST SIDE SAPPERS RIDGE	4	5	1.76	0.15	1.91	1.36	4.28	3.79	11.90	19.44	83.68	995.9	0.00	0.58	1.20	3.00	0.51	1011.3	7029.1	1.00	112.85								1.88	90.93	90.36	
WEST SIDE SAPPERS RIDGE	5	6	2.43	0.11	2.54	1.80	6.08	5.00	16.90	21.32	78.96	1334.4	0.00	0.65	1.20	3.00	0.62	1513.4	7762.6	1.19	82.79								1.16	90.36	89.85	
										22.47																						
NORTH ENTRANCE TO SOMME STREET	8	6		0.03	0.03	0.03	0.03	0.08	0.08	15.00	97.85	7.3	0.00	0.20	1.20	3.00	1.30	94.9	11276.7	0.79	10.00								0.21	89.98	89.85	
										15.21																						
CULVERT CROSSING	6	14		0.00	0.00	0.00	6.11	0.00	16.97	22.47	76.34	1295.8					0.50				20.00	2	----	1.15 x 0.82	NO	YES	0.75	0.38	89.85	89.75		
										22.85																						
NORTH PORTION SOMME STREET	13	14	0.85	0.03	0.88	0.62	0.62	1.73	1.73	15.00	97.85	169.2	0.00	0.30	1.20	3.00	2.30	372.0	14999.4	1.38	10.00								0.12	89.98	89.75	
										15.12																						
NORTH PORTION SOMME STREET	14	15	2.93	0.24	3.17	2.27	8.99	6.30	25.00	22.85	75.52	1888.2	0.00	0.74	1.20	3.00	0.50	1926.6	6992.8	1.17	184.04								2.62	89.75	88.83	
NORTH PORTION SOMME STREET	15	16	2.08	0.18	2.26	1.62	10.61	4.50	29.50	25.47	70.36	2075.4	0.00	0.77	1.20	3.00	0.57	2291.4	7480.8	1.29	145.08								1.88	88.83	88.00	
NORTH PORTION SOMME STREET	16	18	2.34	0.23	2.57	1.85	12.46	5.13	34.63	27.35	67.11	2323.9	0.00	0.80	1.20	3.00	0.51	2399.6	7074.8	1.25	185.66								2.48	88.00	87.05	
NORTH PORTION SOMME STREET	18	19	0.00	0.05	0.05	0.05	12.50	0.13	34.75	29.82	63.30	2199.9	0.00	0.76	1.20	3.00	0.72	2476.8	8372.8	1.43	41.86								0.49	87.05	86.75	
										30.31																						
EAST SIDE SAPPERS RIDGE	9	10	1.74	0.19	1.93	1.39	1.39	3.86	3.86	15.00	97.85	378.0	0.00	0.41	1.20	3.00	0.50	399.2	6996.6	0.79	147.87								3.11	92.40	91.66	
EAST SIDE SAPPERS RIDGE	10	11	1.49	0.14	1.63	1.17	2.56	3.25	7.11	18.11	87.42	622.0	0.00	0.49	1.20	3.00	0.66	735.9	8019.2	1.02	111.04								1.81	91.66	90.93	
EAST SIDE SAPPERS RIDGE	11	12	0.73	0.14	0.87	0.64	3.20	1.77	8.88	19.92	82.40	732.0	0.00	0.52	1.20	3.00	0.55	785.5	7304.8	0.97	104.49								1.80	90.93	90.36	
EAST SIDE SAPPERS RIDGE	12	7	0.18	0.09	0.27	0.21	3.40	0.58	9.46	21.72	78.02	738.2	0.00	0.49	1.20	3.00	0.81	818.5	8919.0	1.14	72.55							1.06	90.36	89.77		
NORTH PORTION SOMME STREET	7	20	1.07	0.23	1.30	0.96	4.36	2.66	12.12	22.79	75.66	916.9	0.00	0.57	1.20	3.00	0.50	956.8	6966.1	0.98	177.39								3.01	89.77	88.89	
NORTH PORTION SOMME STREET	20	21	2.27	0.19	2.46	1.76	6.12	4.89	17.01	25.80	69.76	1186.8	0.00	0.62	1.20	3.00	0.50	1200.1	6981.9	1.04	147.49								2.36	88.89	88.16	
NORTH PORTION SOMME STREET	21	22	3.43	0.30	3.73	2.67	8.79	7.43	24.44	28.16	65.80	1608.1	0.00	0.70	1.20	3.00	0.56	1759.0	7404.4	1.20	232.84								3.24	88.16	86.85	
										31.40																						
<b>SOUTHERN CATCHMENT AREA</b>																																
SOUTH PORTION SOMME STREET	23A	23B	0.00	0.25	0.25	0.23	0.23	0.63	0.63	15.00	97.85	61.2	0.00	0.20	1.20	3.00	0.64	66.3	7883.5	0.55	181.00								5.46	93.65	92.50	
CULVERT CROSSING	23B	23C		0.00	0.00	0.00	0.23	0.00	0.63	20.46	81.05	50.7					0.42				24.00	1	500	----	NO	YES	0.33	1.55	92.50	92.40		
SOUTH PORTION SOMME STREET	23C	24A	0.00	0.17	0.17	0.15	0.38	0.43	1.05	22.00	77.38	81.3	0.00	0.22	1.20	3.00	0.82	97.0	8946.1	0.67	110.00								2.74	92.40	91.50	
CULVERT CROSSING	24A	24B		0.00	0.00	0.00	0.38	0.00	1.05	24.75	71.70	75.3					0.42				24.00	1	500	----	NO	YES	0.34	1.04	91.50	91.40		
SOUTH PORTION SOMME STREET	24B	24C	0.00	0.21	0.21	0.19	0.57	0.53	1.58	25.79	69.78	110.0	0.00	0.25	1.20	3.00	0.70	126.0	8258.2	0.67	142.00								3.52	91.40	90.41	
ORGAWORLD - SITE	U/S	24C	1:10 year peak flow = 132 L/s, see Table 4 of Orgaworld Stormwater Site Management Plan, Sept. 2008																													
SOUTH PORTION SOMME STREET	24C	25	3.70	0.32	4.02	2.88	3.44	8.00	9.58	29.31	64.05	745.3	0.00	0.52	1.20	3.00	0.54	783.8	7289.5	0.97	244.84								4.22	90.41	89.08	
SOUTH PORTION SOMME STREET	25	26	2.63	0.12	2.75	1.95	5.39	5.42	14.99	33.53	58.41	1007.7	0.00	0.58	1.20	3.00	0.51	1013.1	7041.5	1.00	90.75								1.51	89.08	88.62	
SOUTH PORTION SOMME STREET	26	27A	3.15	0.20	3.35	2.39	7.78	6.63	21.63	35.04	56.65	1357.2	0.00	0.62	1.20	3.00	0.65	1370.0	7970.4	1.19	157.06								2.20	88.62	87.60	
SOUTH PORTION SOMME STREET	27A	27B	0.00	0.03	0.03	0.03	7.81	0.08	21.70	37.24	54.29	1310.1	0.00	0.61	1.20	3.00	0.65	1312.4	7973.8	1.18	20.00								0.28	87.60	87.47	
CULVERT CROSSING	27B	27C		0.00	0.00	0.00	7.81	0.00	21.70	37.53	54.00	1303.8					0.73				15.00	1	----	1.39 X 0.97	YES	NO	0.87	0.20	87.47	87.36		
CORNER OF POND	27C	19	0.00	0.11	0.11	0.10	7.88	0.28	21.98	37.73	53.79	1314.2	0.00	0.65	1.20	3.00	0.71	1622.9	8324.0	1.28	72.00								0.94	87.36	86.85	
										38.67																						

**Design Chart 2.32: Inlet Control: Circular CSP and SPCSP Culverts**

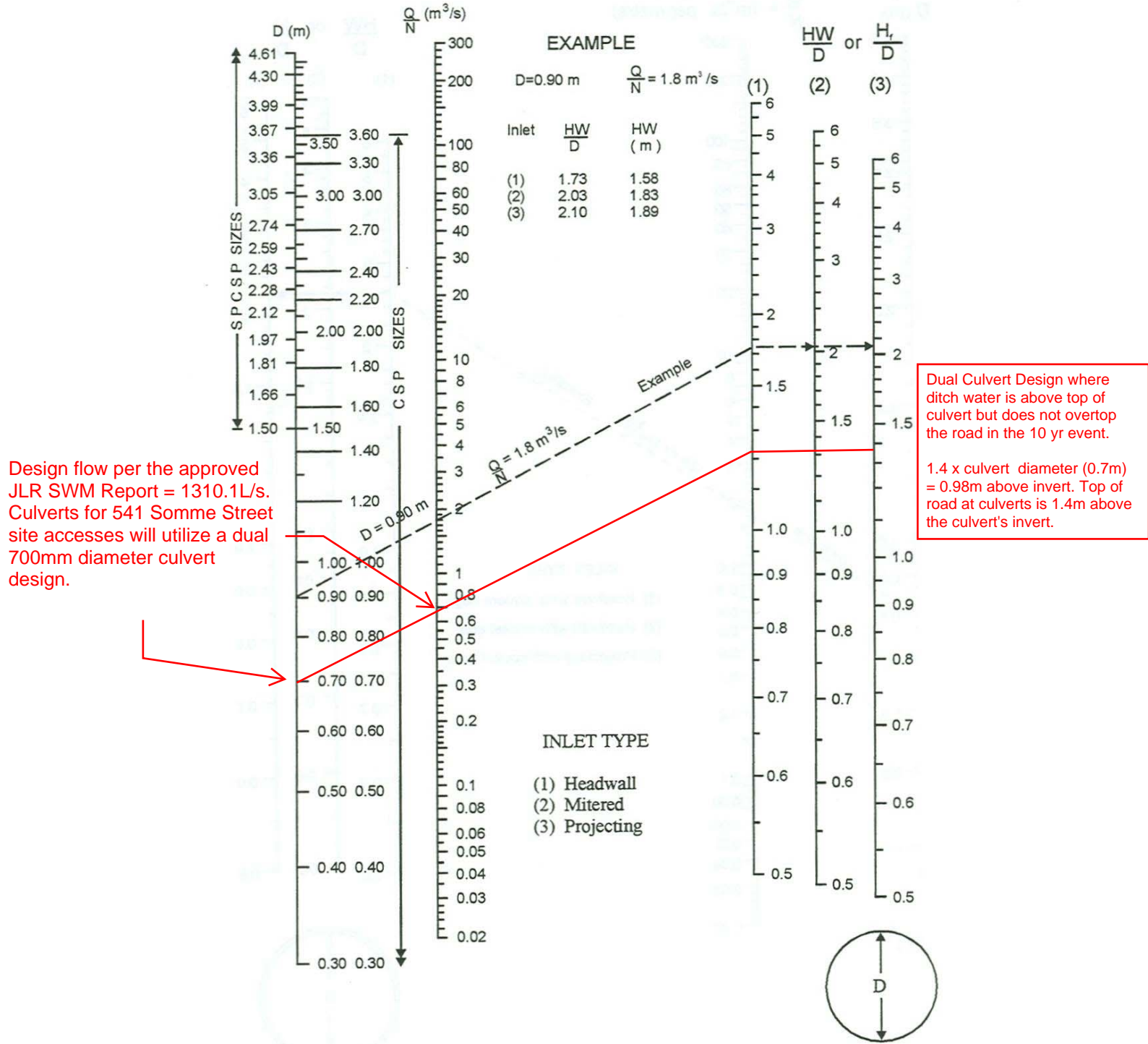

Source: Herr (1977)

541 Somme Street  
Municipal Ditch Water Level  
Calculations

Hawthorne Industrial Park

OPEN DITCH/CULVERT DESIGN SHEET

City of Ottawa

Prepared by: M. Buchanan, E.I.T.

JLR 20983

February 2009 (Revised April 2009)

Checked by: G. Forget, P.Eng.

1:100 year Ottawa International Airport IDF Curve

Increase Runoff Coefficient by 25.0%

DETAILS	NODES		DRAINAGE AREA					PEAK FLOW GENERATION					OPEN DITCH/SWALE DATA							CULVERTS SIZED UNDER 1:10 YEAR STORM EVENT				FLOW TIME (min)	U/S Inv (m)	D/S Inv (m)				
	FROM	TO	Area at C of		SUM(A)	SUM(A*1.25°C) 25% increase in C factor	TOTAL A*°C	2.78AR	2.78AR CUM	TIME min.	INTENS. mm/hr	PEAK FL. l/s	BW m	D m	SS X:1	SLOPE %	CAPAC. l/s	VEL. m/s	LENGTH m	No. of Barrels	DIA (mm)	B x D (m)	INLET CONTROL				OUTLET CONTROL			
			0.70 (ha)	0.90 (ha)																										
<b>NORTHERN CATCHMENT AREA</b>																														
WEST SIDE SAPPERS RIDGE	2	3	1.86	0.18	2.04	1.81	1.81	5.02	5.02	15.00	142.89	718.0	0.00	1.20	3.00	0.50	6973.0	1.61	136.80									1.41	92.50	91.82
WEST SIDE SAPPERS RIDGE	3	4	1.89	0.14	2.03	1.80	3.61	5.00	10.02	16.41	135.47	1357.9	0.00	1.20	3.00	0.80	8856.1	2.05	111.00								0.90	91.82	90.93	
WEST SIDE SAPPERS RIDGE	4	5	1.76	0.15	1.91	1.69	5.29	4.69	14.71	17.31	131.16	1929.7	0.00	1.20	3.00	0.51	7029.1	1.63	112.85								1.16	90.93	90.36	
WEST SIDE SAPPERS RIDGE	5	6	2.43	0.11	2.54	2.23	7.53	6.21	20.92	18.47	126.06	2637.5	0.00	1.20	3.00	0.62	7762.6	1.80	82.79								0.77	90.36	89.85	
										19.24																				
NORTH ENTRANCE TO SOMME STREET	8	6		0.03	0.03	0.03	0.03	0.08	0.08	15.00	142.89	11.9	0.00	1.20	3.00	1.30	11276.7	2.61	10.00								0.06	89.98	89.85	
										15.06																				
CULVERT CROSSING	6	14		0.00	0.00	0.00	7.56	0.00	21.01	19.24	122.91	2581.8				0.50			20.00	2	----	1.15 x 0.82	NO	YES			0.19	89.85	89.75	
										19.43																				
NORTH PORTION SOMME STREET	13	14	0.85	0.03	0.88	0.77	0.77	2.15	2.15	15.00	142.89	307.4	0.00	1.20	3.00	2.30	14999.4	3.47	10.00								0.05	89.98	89.75	
										15.05																				
NORTH PORTION SOMME STREET	14	15	2.93	0.24	3.17	2.80	11.13	7.79	30.95	19.43	122.15	3780.5	0.00	1.20	3.00	0.50	6992.8	1.62	184.04								1.89	89.75	88.83	
NORTH PORTION SOMME STREET	15	16	2.08	0.18	2.26	2.00	13.13	5.56	36.51	21.32	115.16	4204.4	0.00	1.20	3.00	0.57	7480.8	1.73	145.08								1.40	88.83	88.00	
NORTH PORTION SOMME STREET	16	18	2.34	0.23	2.57	2.28	15.41	6.33	42.84	22.72	110.55	4736.0	0.00	1.20	3.00	0.51	7074.8	1.64	185.66								1.89	88.00	87.05	
NORTH PORTION SOMME STREET	18	19	0.00	0.05	0.05	0.05	15.46	0.14	42.98	24.61	104.93	4509.7	0.00	1.20	3.00	0.72	8372.8	1.94	41.86								0.36	87.05	86.75	
										24.97																				
EAST SIDE SAPPERS RIDGE	9	10	1.74	0.19	1.93	1.71	1.71	4.76	4.76	15.00	142.89	680.4	0.00	1.20	3.00	0.50	6996.6	1.62	147.87								1.52	92.40	91.66	
EAST SIDE SAPPERS RIDGE	10	11	1.49	0.14	1.63	1.44	3.16	4.02	8.78	16.52	134.93	1184.3	0.00	1.20	3.00	0.66	8019.2	1.86	111.04								1.00	91.66	90.93	
EAST SIDE SAPPERS RIDGE	11	12	0.73	0.14	0.87	0.78	3.94	2.16	10.94	17.52	130.23	1424.7	0.00	1.20	3.00	0.55	7304.8	1.69	104.49								1.03	90.93	90.36	
EAST SIDE SAPPERS RIDGE	12	7	0.18	0.09	0.27	0.25	4.18	0.69	11.63	18.55	125.73	1462.2	0.00	1.20	3.00	0.81	8919.0	2.06	72.55								0.59	90.36	89.77	
NORTH PORTION SOMME STREET	7	20	1.07	0.23	1.30	1.17	5.35	3.24	14.87	19.13	123.33	1834.1	0.00	1.20	3.00	0.50	6966.1	1.61	177.39								1.83	89.77	88.89	
NORTH PORTION SOMME STREET	20	21	2.27	0.19	2.46	2.18	7.53	6.05	20.92	20.97	116.41	2435.6	0.00	1.20	3.00	0.50	6981.9	1.62	147.49								1.52	88.89	88.16	
NORTH PORTION SOMME STREET	21	22	3.43	0.30	3.73	3.30	10.83	9.18	30.10	22.49	111.29	3350.0	0.00	1.20	3.00	0.56	7404.4	1.71	232.84								2.26	88.16	86.85	
										24.75																				
<b>SOUTHERN CATCHMENT AREA</b>																														
SOUTH PORTION SOMME STREET	23A	23B	0.00	0.25	0.25	0.25	0.25	0.70	0.70	15.00	142.89	99.3	0.00	1.20	3.00	0.64	7883.5	1.82	181.00									1.65	93.65	92.50
CULVERT CROSSING	23B	23C		0.00	0.00	0.00	0.25	0.00	0.70	16.65	134.29	93.3				0.42			24.00	1	500	----	NO	YES			0.84	92.50	92.40	
SOUTH PORTION SOMME STREET	23C	24A	0.00	0.17	0.17	0.17	0.42	0.47	1.17	17.49	130.34	152.2	0.00	1.20	3.00	0.82	8946.1	2.07	110.00									0.89	92.40	91.50
CULVERT CROSSING	24A	24B		0.00	0.00	0.00	0.42	0.00	1.17	18.38	126.45	147.6				0.42			24.00	1	500	----	NO	YES			0.53	91.50	91.40	
SOUTH PORTION SOMME STREET	24B	24C	0.00	0.21	0.21	0.21	0.63	0.58	1.75	18.91	124.24	217.6	0.00	1.20	3.00	0.70	8258.2	1.91	142.00								1.24	91.40	90.41	
ORGAWORLD - SITE	U/S	24C	1:100 year peak flow = 283 l/s, see Table 4 of Orgaworld Stormwater Site Management Plan, Sept. 2008										283.0																	
SOUTH PORTION SOMME STREET	24C	25	3.70	0.32	4.02	3.56	4.19	9.89	11.64	20.15	119.40	1672.8	0.00	1.20	3.00	0.54	7289.5	1.69	244.84								2.42	90.41	89.08	
SOUTH PORTION SOMME STREET	25	26	2.63	0.12	2.75	2.42	6.61	6.73	18.37	22.57	111.05	2323.0	0.00	1.20	3.00	0.51	7041.5	1.63	90.75								0.93	89.08	88.62	
SOUTH PORTION SOMME STREET	26	27A	3.15	0.20	3.35	2.96	9.57	8.22	26.59	23.49	108.17	3159.5	0.00	1.20	3.00	0.65	7970.4	1.84	157.06								1.42	88.62	87.60	
SOUTH PORTION SOMME STREET	27A	27B	0.00	0.03	0.03	0.03	9.60	0.08	26.67	24.91	104.09	3059.5	0.00	1.20	3.00	0.65	7973.8	1.85	20.00								0.18	87.60	87.47	
CULVERT CROSSING	27B	27C		0.00	0.00	0.00	9.60	0.00	26.67	25.09	103.59	3046.2				0.73			15.00	1	----	1.39 X 0.97	YES	NO			0.09	87.47	87.36	
CORNER OF POND	27C	19	0.00	0.11	0.11	0.11	9.71	0.31	26.98	25.18	103.36	3071.7	0.00	1.20	3.00	0.71	8324.0	1.93	72.00								0.62	87.36	86.85	
										25.80																				

JLR - Hawthorne Industrial Park Storm Design Sheet Data (Report Dated May 2009)						
TABLE 11A: 1:100 Year Open Ditch/Culvert Design Sheet						
Nodes		Peak Flow Generation				
From	To	2.78AR CUM	TC (min)	I <sub>10</sub> (mm/hr)	OrgWorld SWMF (L/s)	Peak Flow (L/s)
27A	27B	21.7	37.53	54.00	132	1303.8

JLR - Hawthorne Industrial Park Storm Design Sheet Data (Report Dated May 2009)						
TABLE 11B: 1:100 Year Open Ditch/Culvert Design Sheet						
Nodes		Peak Flow Generation				
From	To	2.78AR CUM	TC (min)	I <sub>10</sub> (mm/hr)	OrgWorld SWMF (L/s)	Peak Flow (L/s)
27A	27B	26.67	24.91	104.09	283	3059.5

- a) The JLR Hawthorne Industrial Park SWM Report only analyzed the 10yr and 100yr storm events (see above for Nodes which reflect immediately downstream of the 541 Somme Street Development).
- b) The Intensity value of the 2yr (I<sub>2</sub>) and 5yr (I<sub>5</sub>) storm event have been approximated based on a percentage of variance of the rainfall intensity utilizing the TC from the JLR assessed 10yr storm event. (see below)
- c) Also, the flows for the 2yr and 5yr storm events has been assessed below based on the approximated Intensities and the Time of Concentration (TC) used in the 10yr storm event peak flow calculation. (see

TABLE 11C: I <sub>2</sub> and I <sub>5</sub> Approximation				
Design Item	Abbrev.			% of I <sub>10</sub>
Time of Concentration	Tc=	37.53	min	
Intensity (10 Year Event)	I <sub>10</sub> =	54.00	mm/hr	1.00
Intensity (5 Year Event)	I <sub>5</sub> =	46.22	mm/hr	0.86
Intensity (2 Year Event)	I <sub>2</sub> =	34.36	mm/hr	0.64

Table 11D: 2yr and 5yr Approximate Flows				
Outlet Options	2.78AR	Tc (min)	Q <sub>2</sub> Year (L/s)	Q <sub>5</sub> Year (L/s)
27C	21.70	37.53	829.7	1115.9

Equations:  
 Flow Equation  
 $Q = 2.78AR \times I$

Where:  
 R is the runoff coefficient  
 I is the rainfall intensity, City of Ottawa IDF

A is the total drainage area

100 year Intensity =  $1735.688 / (\text{Time in min} + 6.014)^{0.820}$   
 10 year Intensity =  $1174.184 / (\text{Time in min} + 6.014)^{0.816}$   
 5 year Intensity =  $998.071 / (\text{Time in min} + 6.053)^{0.814}$   
 2 year Intensity =  $732.951 / (\text{Time in min} + 6.199)^{0.810}$

**Design Chart 5.43: Inlet Control: Steel Pipe Arch Culverts**

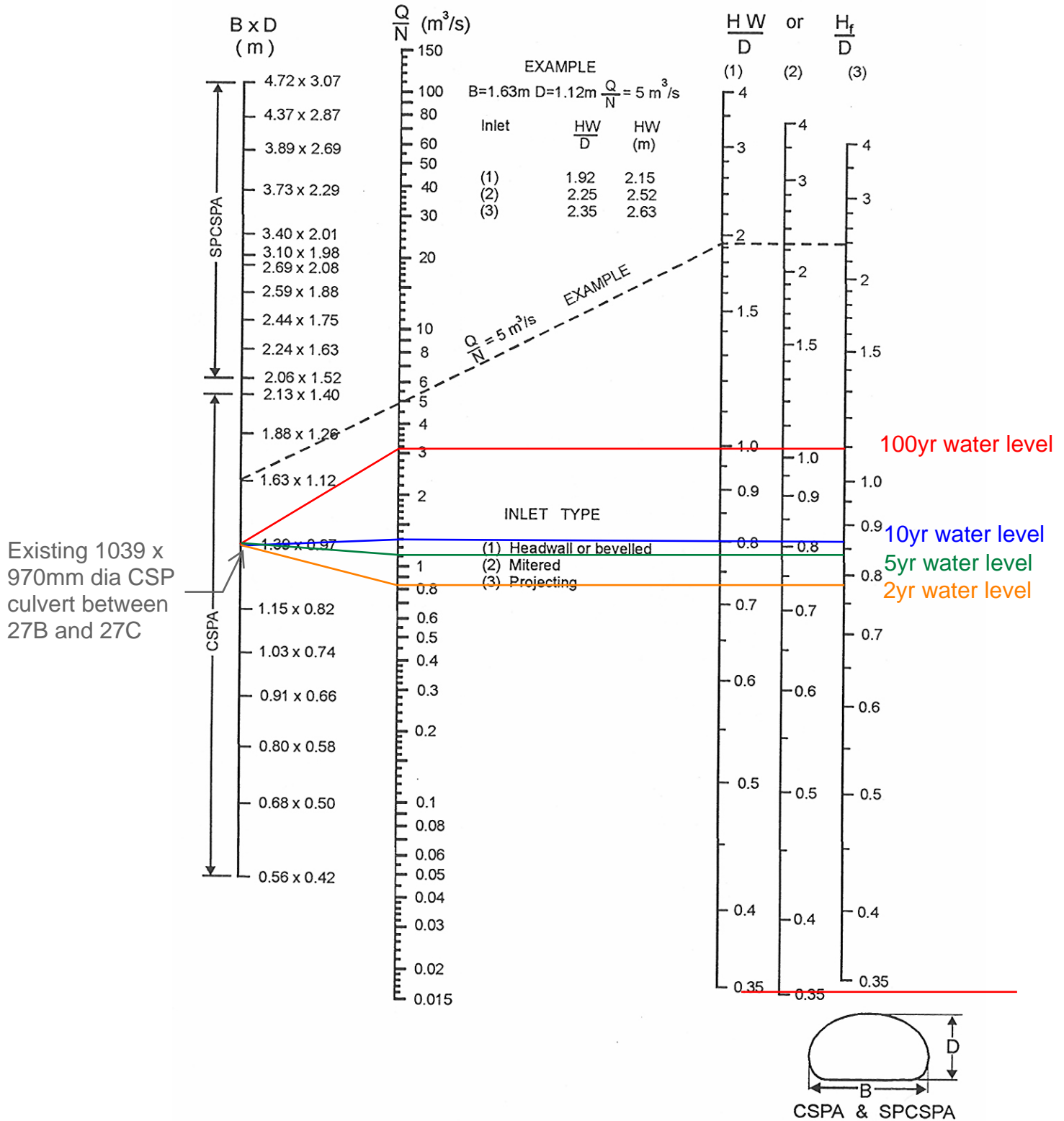

Source: Herr (1977)

## Geotechnical Foundation Drain Recommendation

---

## **6.0 Design and Construction Precautions**

### **6.1 Foundation Drainage and Backfill**

#### **Foundation Drainage and Backfill**

As the proposed building will not contain below-grade space, and the subsurface conditions consist of relatively shallow bedrock, foundation drainage is not required for the proposed building.

However, since the proposed building will be immediately surrounded by walkways, it is recommended that the exterior of the foundation walls be backfilled with free-draining, non frost susceptible fill such as OPSS Granular B Type I or II granular material.

### **6.2 Protection of Footings Against Frost Action**

Perimeter footings of heated structures are recommended to be insulated against the deleterious effects of frost action. Generally, a minimum 1.5 m thick soil cover, or an equivalent combination of soil cover and foundation insulation, should be provided in this regard.

Exterior unheated footings, such as isolated piers, are more prone to deleterious movement associated with frost action than the exterior walls of the structure, and generally require additional protection, such as soil cover of 2.1 m, or an equivalent combination of soil cover and foundation insulation.

However, foundations which are founded directly on clean, surface-sounded bedrock with no cracks or fissures, and which is approved by Paterson at the time of construction, is not considered frost susceptible and does not require soil cover.

### **6.3 Excavation Side Slopes**

The side slopes of the excavations in the soil and fill overburden materials should either be cut back at acceptable slopes or should be retained by shoring systems from the start of the excavation until the structure is backfilled. It is expected that sufficient room will be available for the greater part of the excavation to be undertaken by open-cut methods (i.e. unsupported excavations).

**From:** Ryan Good <[r.good@novatech-eng.com](mailto:r.good@novatech-eng.com)>  
**Sent:** December 22, 2025 1:10 PM  
**To:** Lalonde, Patrick (MECP) <[Patrick.Lalonde@ontario.ca](mailto:Patrick.Lalonde@ontario.ca)>  
**Cc:** Greg MacDonald <[g.Macdonald@novatech-eng.com](mailto:g.Macdonald@novatech-eng.com)>; Anthony Mestwarp <[a.mestwarp@novatech-eng.com](mailto:a.mestwarp@novatech-eng.com)>  
**Subject:** 541 Somme Street - Industrial Site ECA - (124111)

**CAUTION -- EXTERNAL E-MAIL - Do not click links or open attachments unless you recognize the sender.**

Good afternoon Patrick,

Please note we have a client who is looking to develop within the Hawthorne Industrial Park in Ottawa. The development proposes a building with office space in the front and a warehouse in the back. As part of the development, and in accordance with the Industrial Park's approved SWM Report (by JLR, dated May 2009), our development requires an OGS unit to provide on-site stormwater quality control.

In the Pre-consultation with the City, they noted the need for an ECA due to the Industrial designation of the property and provided your name as a contact for the MECP. I have attached a copy of the Pre-consultation minutes, as well as our latest Servicing Plan which shows the site and SWM infrastructure layout.

Would you be available to meet and discuss the development and the applicable ECA process (CLI-ECA, EASR, ToR, etc.)? Let me know if you need anything else from me to support this request.

Thanks,

**Ryan Good, C.E.T., Design Technologist | Land Development and Public Sector  
Infrastructure**

**NOVATECH**

Engineers, Planners & Landscape Architects

240 Michael Cowpland Drive, Suite 200, Ottawa, ON, K2M 1P6 | Tel: 613.254.9643 Ext: 284  
| Cell: 343-364-2246

**From:** Lalonde, Patrick (MECP) <[Patrick.Lalonde@ontario.ca](mailto:Patrick.Lalonde@ontario.ca)>  
**Sent:** Monday, December 22, 2025 1:21 PM  
**To:** Ryan Good <[r.good@novatech-eng.com](mailto:r.good@novatech-eng.com)>; Cote, Joff (MECP) <[Joff.Cote@ontario.ca](mailto:Joff.Cote@ontario.ca)>  
**Subject:** FW: 541 Somme Street - Industrial Site ECA - (124111)

Hi Ryan,

I've included Environmental Officer Joff Cote in this correspondence. Joff will be your primary point of contact regarding your request and can provide guidance related to this site and the application process.

Pat Lalonde

(A) Compliance Supervisor | Ottawa District Office | Eastern Region

(P.I.) Superviseur de district | Bureau de district d'Ottawa | Région de l'Est

Ministry of the Environment, Conservation and Parks | Government of Ontario

Ministère de l'Environnement, de la Protection de la nature et des Parcs | Gouvernement de l'Ontario

Tel: 613-363-1652 | Email: [Patrick.Lalonde@ontario.ca](mailto:Patrick.Lalonde@ontario.ca)

2430 Don Reid Drive, Unit 103

Ottawa, ON, K1H 1E1

**Ontario** 

**From:** Ryan Good <[r.good@novatech-eng.com](mailto:r.good@novatech-eng.com)>

**Sent:** December 22, 2025 1:24 PM

**To:** Lalonde, Patrick (MECP) <[Patrick.Lalonde@ontario.ca](mailto:Patrick.Lalonde@ontario.ca)>; Cote, Joff (MECP) <[Joff.Cote@ontario.ca](mailto:Joff.Cote@ontario.ca)>

**Subject:** RE: 541 Somme Street - Industrial Site ECA - (124111)

**CAUTION -- EXTERNAL E-MAIL - Do not click links or open attachments unless you recognize the sender.**

Great, thanks Patrick.

Hi Joff, the details of my request can be seen in the emails below. Please let me know if you require anything further to support my request.

Thanks,

**Ryan Good**, C.E.T., Design Technologist | Land Development and Public Sector  
Infrastructure

**NOVATECH**

Engineers, Planners & Landscape Architects

240 Michael Cowpland Drive, Suite 200, Ottawa, ON, K2M 1P6 | Tel: 613.254.9643 Ext: 284  
| Cell: 343-364-2246

240 Michael Cowpland Drive, Suite 200, Ottawa, ON, K2M 1P6 | Tel: 613.254.9643 Ext: 284  
| Cell: 343-364-2246

**From:** Cote, Joff (MECP) <[Joff.Cote@ontario.ca](mailto:Joff.Cote@ontario.ca)>  
**Sent:** Monday, December 22, 2025 3:28 PM  
**To:** Ryan Good <[r.good@novatech-eng.com](mailto:r.good@novatech-eng.com)>  
**Cc:** Cote, Joff (MECP) <[Joff.Cote@ontario.ca](mailto:Joff.Cote@ontario.ca)>  
**Subject:** RE: 541 Somme Street - Industrial Site ECA - (124111)

Good afternoon Ryan,

I will need more information on the land use and the type of warehousing before I can provide more direction.

Can you please provide responses to the following questions:

- What type of materials/goods will be stored in the warehouse?
- Will any transformation of materials/good occur in the warehouse?
- Will any materials/goods be stored (for any length of time) outside the warehouse? And if so, what type(s) and for up to how long?
- Will any heavy equipment (e.g., forklift and bigger, including transport trucks) be stored/parked outside? And if so, will they also be serviced outside the warehouse?
- Will any heavy equipment (e.g., forklift and bigger, including transport trucks) be serviced inside the warehouse?

FYI, I'm heading on vacation for the holiday season but will respond to you first thing upon my return on January 5<sup>th</sup>, 2026.

Thanks,

Joffre Côté  
Environmental Compliance Officer, Badge # P1555  
Ottawa District Office  
Drinking Water and Environmental Compliance Division  
Ministry of the Environment, Conservation and Parks, Government of Ontario  
Tel: 613-410-9217  
[joff.cote@ontario.ca](mailto:joff.cote@ontario.ca)  
2430 Don Reid Drive, Unit 103  
Ottawa, ON K1H 1E1

**Ontario** 

**From:** Ryan Good <[r.good@novatech-eng.com](mailto:r.good@novatech-eng.com)>  
**Sent:** December 22, 2025 4:26 PM  
**To:** Cote, Joff (MECP) <[Joff.Cote@ontario.ca](mailto:Joff.Cote@ontario.ca)>  
**Cc:** Greg MacDonald <[g.Macdonald@novatech-eng.com](mailto:g.Macdonald@novatech-eng.com)>; Anthony Mestwarp <[a.mestwarp@novatech-eng.com](mailto:a.mestwarp@novatech-eng.com)>; Juice Lambert <[juice.lambert@titanenviro.com](mailto:juice.lambert@titanenviro.com)>; Lucky Montierro <[lucky.montierro@titanenviro.com](mailto:lucky.montierro@titanenviro.com)>  
**Subject:** RE: 541 Somme Street - Industrial Site ECA - (124111)

Hi Joff,

Please see below (in blue) for additional project/site/storage details. I have included the developers from Titan Environmental (Juice Lambert and Lucky Montierro) to this email as well; Juice and Lucky please let me know if I get any details wrong in my responses.

- What type of materials/goods will be stored in the warehouse?

The warehouse will be used to store stormwater management products (Plastic Drainage Parts, Polymeric Sand, Landscaping Edging, etc.

- Will any transformation of materials/good occur in the warehouse?

The warehouse will not be used to manufacture or transform any materials or goods. The warehouse is intended for storage

- Will any materials/goods be stored (for any length of time) outside the warehouse? And if so, what type(s) and for up to how long?

Some products are planned for outdoor storage. These products include items such as plastic pipes, burlap, silt socks, woven and unwoven geotextile.

- Will any heavy equipment (e.g., forklift and bigger, including transport trucks) be stored/parked outside? And if so, will they also be serviced outside the warehouse?

Transport vehicles will attend the site periodically to deliver material; no transports will be stored on site. A forklift is intended to be kept on-site and when parked outside, it will be stored under the lean to shown on the south side of the building.

- Will any heavy equipment (e.g., forklift and bigger, including transport trucks) be serviced inside the warehouse?

I believe the Forklift would be serviced on-site when required. (Juice or Lucky, can you please confirm?)

Enjoy your holidays! We will look forward to picking this up in the New Year.

Thanks,

**Ryan Good**, C.E.T., Design Technologist | Land Development and Public Sector  
Infrastructure  
**NOVATECH**  
Engineers, Planners & Landscape Architects

**From:** Cote, Joff (MECP) <[Joff.Cote@ontario.ca](mailto:Joff.Cote@ontario.ca)>  
**Sent:** Monday, January 5, 2026 8:37 AM  
**To:** Ryan Good <[r.good@novatech-eng.com](mailto:r.good@novatech-eng.com)>  
**Cc:** Greg MacDonald <[g.Macdonald@novatech-eng.com](mailto:g.Macdonald@novatech-eng.com)>; Anthony Mestwarp <[a.mestwarp@novatech-eng.com](mailto:a.mestwarp@novatech-eng.com)>; Juice Lambert <[juice.lambert@titanenviro.com](mailto:juice.lambert@titanenviro.com)>; Lucky Montierro <[lucky.montierro@titanenviro.com](mailto:lucky.montierro@titanenviro.com)>; Cote, Joff (MECP) <[Joff.Cote@ontario.ca](mailto:Joff.Cote@ontario.ca)>  
**Subject:** RE: 541 Somme Street - Industrial Site ECA - (124111)

Good morning Ryan,

Based on the information provided, this site qualifies for registration under the Industrial Stormwater Management Environmental Activity and Sector Registry (EASR): [Storm water management works guidance for the Environmental Activity and Sector Registry | ontario.ca](#)

Please let me know if you have any follow up questions after reviewing the guidance documentation in the above-noted webpage(s).

Thanks,

Joffre Côté  
Environmental Compliance Officer, Badge # P1555  
Ottawa District Office  
Drinking Water and Environmental Compliance Division  
Ministry of the Environment, Conservation and Parks, Government of Ontario  
Tel: 613-410-9217  
[joff.cote@ontario.ca](mailto:joff.cote@ontario.ca)  
2430 Don Reid Drive, Unit 103  
Ottawa, ON K1H 1E1

**Ontario** 

**From:** Ryan Good <[r.good@novatech-eng.com](mailto:r.good@novatech-eng.com)>  
**Sent:** January 21, 2026 1:09 PM  
**To:** Cote, Joff (MECP) <[Joff.Cote@ontario.ca](mailto:Joff.Cote@ontario.ca)>  
**Cc:** Greg MacDonald <[g.Macdonald@novatech-eng.com](mailto:g.Macdonald@novatech-eng.com)>; Anthony Mestwarp <[a.mestwarp@novatech-eng.com](mailto:a.mestwarp@novatech-eng.com)>; Juice Lambert <[juice.lambert@titanenviro.com](mailto:juice.lambert@titanenviro.com)>; Lucky Montierro <[lucky.montierro@titanenviro.com](mailto:lucky.montierro@titanenviro.com)>  
**Subject:** RE: 541 Somme Street - Industrial Site ECA - (124111)

**CAUTION -- EXTERNAL E-MAIL - Do not click links or open attachments unless you recognize the sender.**

Hi Joff,

Thanks for confirming the development falls under the EASR registration process. We have registered the site under the My Ontario Portal and once the Servicing/SWM Report receives City approval we will upload the file.

Also, the warehouse portion of the building is required to have a floor drain as per standard practices. It is proposed that the floor drain will be provided with an OGS unit and connected to the buildings internal sanitary plumbing network. The floor drain flows will then be discharged into the Tertiary Septic System which include a Waterloo Anerobic Digester, a Bulk Filled Concrete Tank, and a Septic Bed (See Attachment #1 for Septic details).

Can you please confirm if from the MECP's perspective, the floor drain's OGS unit fall under the EASR scope? Will it need to be addressed in the same capacity as the Storm system's OGS Unit (ETV protocol, Maintenance and Operation details, etc)?

Thanks,

**Ryan Good**, C.E.T., Design Technologist | Land Development and Public Sector  
Infrastructure

**NOVATECH**

Engineers, Planners & Landscape Architects

240 Michael Cowpland Drive, Suite 200, Ottawa, ON, K2M 1P6 | Tel: 613.254.9643 Ext: 284  
| Cell: 343-364-2246

**From:** Cote, Joff (MECP) <Joff.Cote@ontario.ca>  
**Sent:** Wednesday, January 21, 2026 1:35 PM  
**To:** Ryan Good <r.good@novatech-eng.com>  
**Cc:** Greg MacDonald <g.Macdonald@novatech-eng.com>; Anthony Mestwarp <a.mestwarp@novatech-eng.com>; Juice Lambert <juice.lambert@titanenviro.com>; Lucky Montierro <lucky.montierro@titanenviro.com>; Cote, Joff (MECP) <Joff.Cote@ontario.ca>  
**Subject:** RE: 541 Somme Street - Industrial Site ECA - (124111)

Hi Ryan,

Since the floor drain's OGS unit is unrelated to Stormwater Management (SW) given that it will be draining to the sanitary treatment, it does not fall under the scope of the SW EASR.

However, I'm thinking that it should probably be approved by the municipality under the Ontario Building Code.

I hope this helps, let me know if you have any other questions.

Joffre Côté  
Environmental Compliance Officer, Badge # P1555  
Ottawa District Office  
Drinking Water and Environmental Compliance Division  
Ministry of the Environment, Conservation and Parks, Government of Ontario  
Tel: 613-410-9217  
[joff.cote@ontario.ca](mailto:joff.cote@ontario.ca)  
2430 Don Reid Drive, Unit 103  
Ottawa, ON K1H 1E1

**Ontario** 

## Appendix E

### Legal Plan

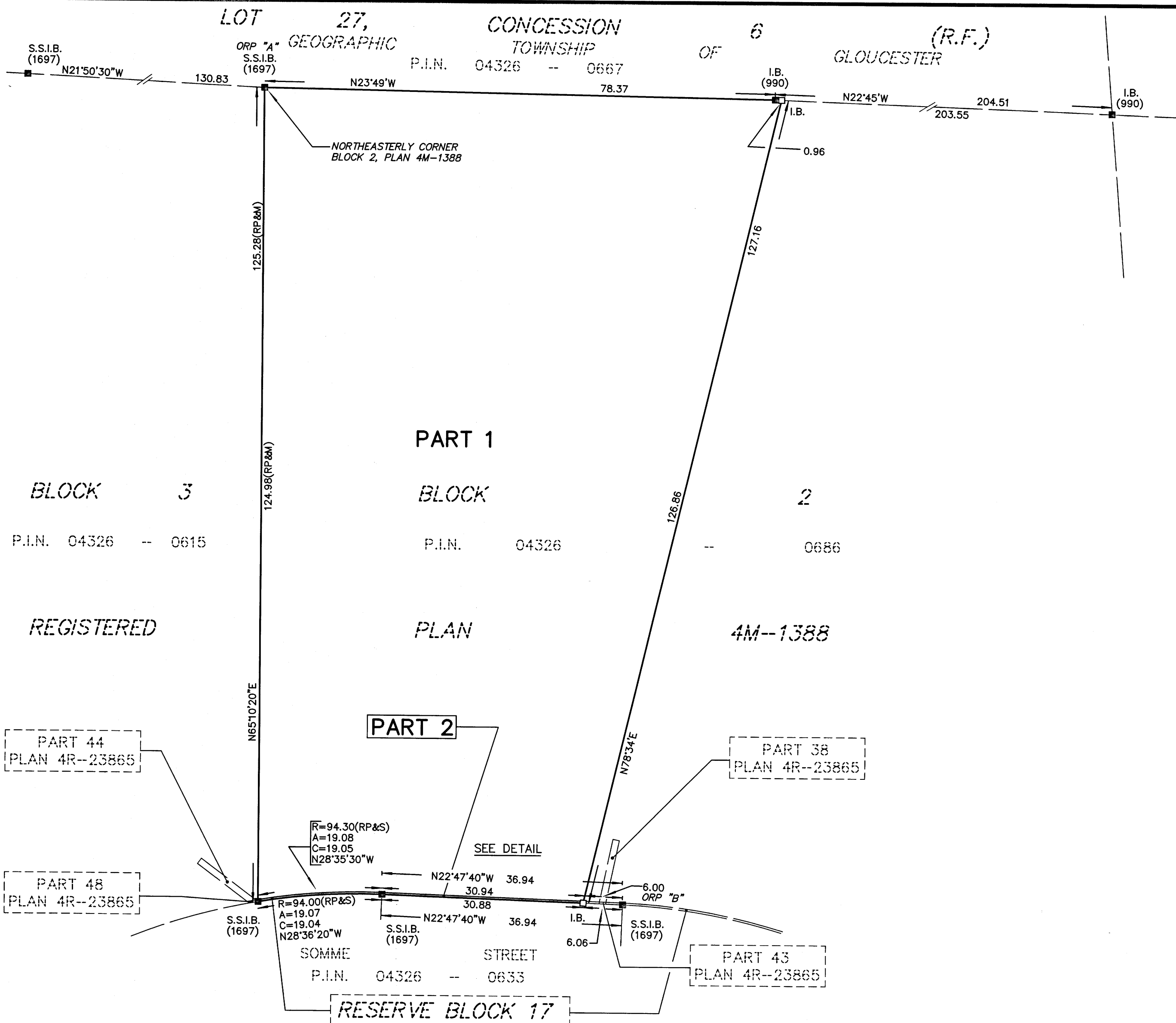

I REQUIRE THIS PLAN TO BE DEPOSITED UNDER THE LAND TITLES ACT.  
 DATE OCTOBER 3, 2024  
 J.P. SHIPMAN

**PLAN 4R-36431**  
 RECEIVED AND DEPOSITED  
 DATE October 7, 2024  
 Yang Liu  
 REPRESENTATIVE FOR THE LAND TITLES DIVISION OF OTTAWA-CARLETON (No.4)

PLAN OF SURVEY OF  
**PART OF BLOCKS 2 AND RESERVE BLOCK 17**  
**REGISTERED PLAN 4M-1388**  
 CITY OF OTTAWA  
 SCALE 1:500



SCHEDULE			
PART	BLOCK	PLAN	P.I.N.
1	PART OF 2	4M-1388	PART OF 04326-0686
2	PART OF RESERVE BLOCK 17		PART OF 04326-0682

**METRIC**  
 DISTANCES AND COORDINATES SHOWN ON THIS PLAN ARE IN METRES AND CAN BE CONVERTED TO FEET BY DIVIDING BY 0.3048

**NOTES**  
 BEARINGS SHOWN ON THIS PLAN ARE GRID BEARINGS, DERIVED FROM CAN-NET 2016 REAL TIME NETWORK OBSERVATIONS ON OBSERVED REFERENCE POINTS (ORP "A" AND ORP "B") SHOWN HEREON, HAVING A BEARING BETWEEN THEM OF N41°08'10"E AND ARE REFERENCED TO THE CENTRAL MERIDIAN OF MTM ZONE 9 (76° 30' WEST LONGITUDE), NAD 83 (CSRS)(2010)

DISTANCES SHOWN ON THIS PLAN ARE HORIZONTAL GROUND DISTANCES AND CAN BE CONVERTED TO GRID DISTANCES BY MULTIPLYING BY THE COMBINED SCALE FACTOR OF 0.999954.

- S.I.B. DENOTES 0.025 SQ., 1.2 LONG, STANDARD IRON BAR
- S.S.I.B. DENOTES 0.025 SQ., 0.6 LONG, SHORT STANDARD IRON BAR
- I.B. DENOTES 0.016 SQ., 0.6 LONG, IRON BAR
- R.I.B. DENOTES ROUND IRON BAR
- DENOTES SURVEY MONUMENT FOUND
- DENOTES SURVEY MONUMENT PLANTED
- WIT. DENOTES WITNESS
- S.U. DENOTES SOURCE UNKNOWN
- 990 DENOTES J.G. PAYETTE, O.L.S.
- 1697 DENOTES J.P. SHIPMAN, O.L.S.
- RP DENOTES REGISTERED PLAN 4M-1388
- M DENOTES MEASURED
- S DENOTES SET

OBSERVED REFERENCE POINTS (ORP): MTM ZONE 9, NAD 83(CSRS)(2010)		
POINT IDENTIFICATION	NORTHING	EASTING
ORP A	5018932.24	379697.87
ORP B	5018828.88	379607.59

COORDINATES SHOWN TO URBAN ACCURACY IN ACCORDANCE WITH O.REG 216/10, SECTIONS 14, AND 31 TO 35 (BOTH INCLUSIVE).  
 COORDINATES CANNOT, IN THEMSELVES, BE USED TO RE-ESTABLISH CORNERS OR BOUNDARIES SHOWN ON THIS PLAN

**SURVEYOR'S CERTIFICATE**

I CERTIFY THAT:  
 (1) THIS SURVEY AND PLAN ARE CORRECT AND IN ACCORDANCE WITH THE SURVEYS ACT, THE SURVEYORS ACT AND THE LAND TITLES ACT AND THE REGULATIONS MADE UNDER THEM;  
 (2) THE SURVEY WAS COMPLETED ON THE 12th DAY OF SEPTEMBER, 2024.

DATE OCTOBER 3, 2024  
 J.P. SHIPMAN  
 ONTARIO LAND SURVEYOR

THIS PLAN OF SURVEY RELATES TO AOLS PLAN SUBMISSION FORM NUMBER 2218812

**ANNIS, O'SULLIVAN, VOLLEBEKK LTD.**  
 113 Prescott Street, Box 1340  
 Kemptville, Ontario K0G 1J0  
 Phone: (613) 258-1717  
 Email: Kemptville@aosvtt.com

Ontario Land Surveyors  
 FILE No.: K-13653-24

