

PLOT DATE: 2025/09/19 2:05:08 PM

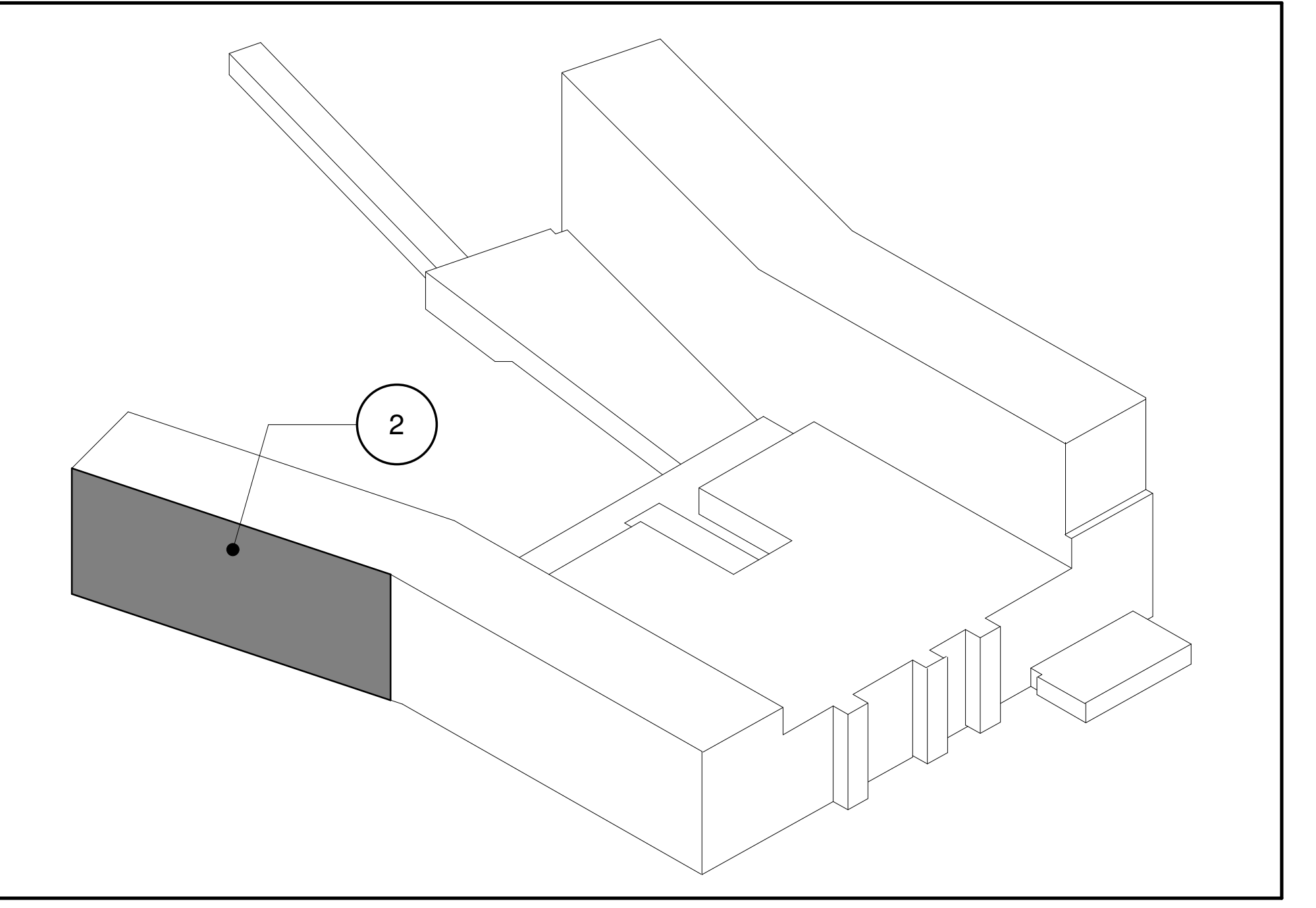
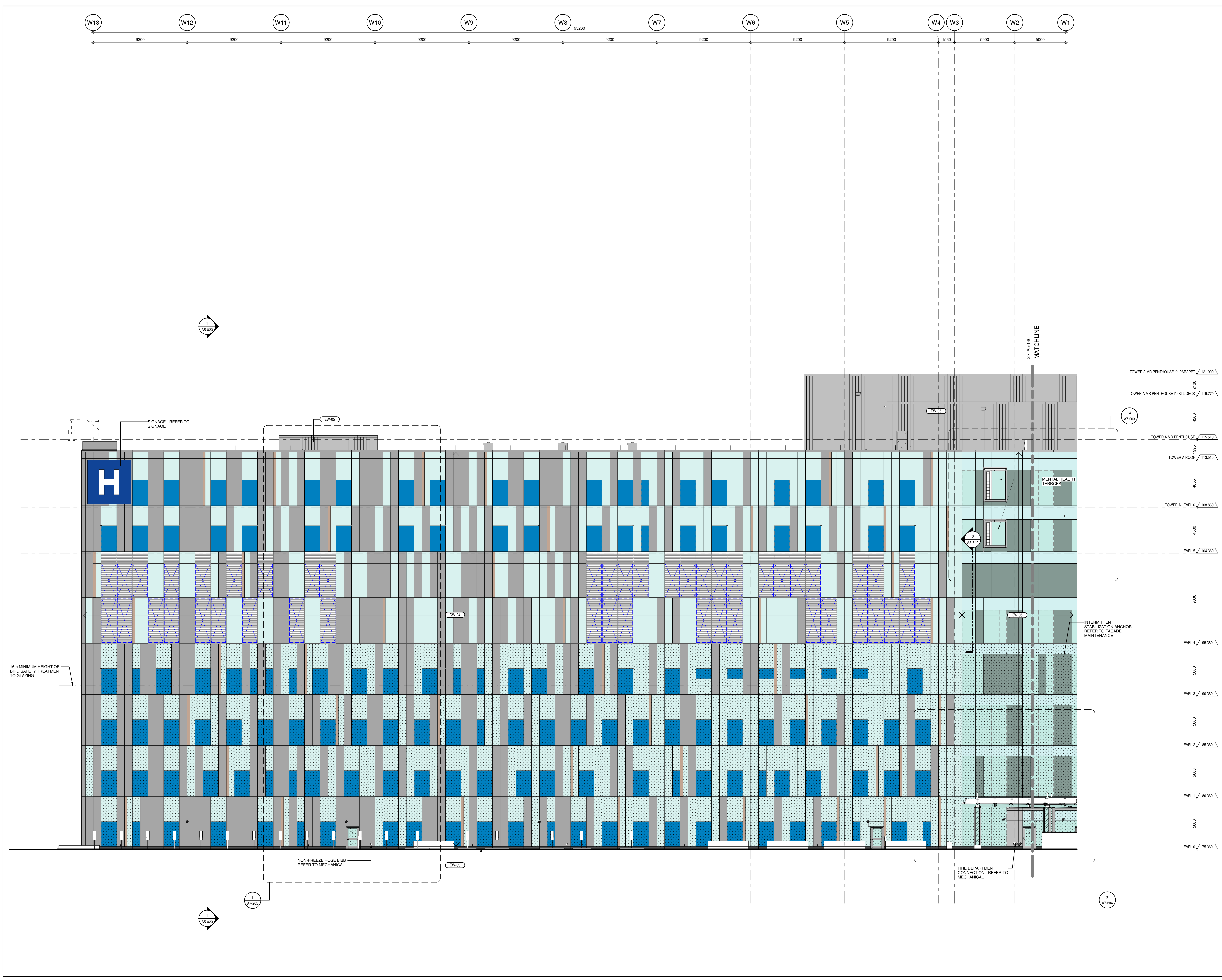

3D KEY 1

GENERAL NOTES
FOR CLADDING GENERAL NOTES, REFER TO A5-110

ELEVATION - WEST TRUE ELEVATION TOWER A
A5-110
1-100

File Number:
D07-12-26-0008 (Revision)
D07-12-23-0168 (Original)
Plan Number: 19424

PROJECT
THE OTTAWA HOSPITAL
NEW CAMPUS
DEVELOPMENT -
PHASE 4 MAIN HOSPITAL
BUILDING
900 CARLING AVE. OTTAWA, ONTARIO

CLIENT
The Ottawa Hospital | L'Hôpital d'Ottawa

Infrastructure Ontario

PCL CONSTRUCTION | **EllisDon**

CLIENT PROJECT NO.
1070002

KEY PLAN
TRUE NORTH | PROJECT NORTH

REVISIONS

NO.	DESCRIPTION	DATE
01	ISSUE FOR PERMIT	2024-03-01
02	DESIGN BUILD BASELINE SUBMISSION	2024-03-05
03	95% DD SUBMISSION	2025-09-19

DRAWING STATUS
NOT FOR CONSTRUCTION
DISCREPANCIES MUST BE REPORTED IMMEDIATELY TO THE ARCHITECT BEFORE PROCEEDING. ONLY PLOTTED DIMENSIONS ARE TO BE USED. CONTRACTORS MUST CHECK ALL DIMENSIONS ON SITE. THIS DRAWING IS PROTECTED BY COPYRIGHT.
ALL DIMENSIONS ARE SHOWN IN METRIC.

AUTHOR
adamson ASSOCIATES ARCHITECTS
A Partnership of Corporations

PROJECT TEAM
DESIGN-BUILDER PCL/ED A JOINT VENTURE
ARCHITECTURAL PARON ARCHITECTS LIMITED, JOSHUA LAMARIE PRATTE ARCHITECTS, ADAMSON ASSOCIATES ARCHITECTS, 888 ARCHITECTS OTTAWA INC.
STRUCTURAL SIMAS OPEN CANADA INC., BOUTHILLETTE PARIZEAU INC.
MECHANICAL HH ANGUS & ASSOCIATES LTD., SIMAS OPEN CANADA INC.
ELECTRICAL MELVEY SIMAN INTERNATIONAL INC.
CIVIL WSP | SIMAS INC.
LANDSCAPE VERDECO DESIGN INC., PWP LANDSCAPE ARCHITECTURE
BUILDING CODE UMOG BUILDING CODE CONSULTANTS LTD.
AUTHOR PROJECT NO. 2233-00

STAMP | **STAMP**

DRAWING TITLE
PARTIAL TRUE ELEVATIONS WEST

DRAWN	CHECKED
AAA-PT	JM

SCALE AT 4" x 6" | DATE 19 SEP 2025
AS NOTED

GRAPHIC SCALE | SCALE IN METERS

A5-141 | **03**