

Stormwater Management - Grading & Drainage - Storm & Sanitary Sewers - Watermains

700 Long Point Circle
Ottawa, Ontario K1T 4E9

613-425-8044
d.gray@dbgrayengineering.com

SITE SERVICING & STORMWATER MANAGEMENT REPORT

1770 HEATHERINGTON ROAD
BUILDING 1
OTTAWA, ONTARIO

REPORT No. 24135-1

MARCH 5, 2026

CONTENTS

- 1.0 INTRODUCTION
- 2.0 WATER SERVICING
 - 2.1 WATER SUPPLY FOR FIREFIGHTING
 - 2.2 DOMESTIC WATER SUPPLY
- 3.0 SANITARY SERVICING
- 4.0 STORMWATER MANAGEMENT
 - 4.1 QUANTITY CONTROL
 - 4.2 QUALITY CONTROL
 - 4.3 STORM SERVICING
- 5.0 CONCLUSIONS

LIST OF APPENDICES

- A WATER SERVICING
- B SANITARY SERVICING
- C STORMWATER MANAGEMENT

1.0 INTRODUCTION

This report has been prepared in support of the Site Plan Control application for the proposed 4-storey, 45-unit apartment building (Building 1) located at 1770 Heatherington Road in Ottawa, Ontario. This report describes the servicing for the proposed building and stormwater management for the 1,890 sq.m property.

This report forms part of the site servicing and stormwater management design for the proposed development. Also refer to drawings C-1 to C-22 prepared by D.B. Gray Engineering Inc.

2.0 WATER SERVICING

2.1 WATER SUPPLY FOR FIREFIGHTING

The proposed building will have a fully supervised sprinkler system with the fire department connection located on the Heatherington Road facade. The sprinkler system is to be designed, installed and maintained in accordance with NFPA standards and the Fire Underwriters Survey. Refer to Appendix A. There is an existing municipal Class AA fire hydrant located at the NE corner of the subject property. It is 30 m unobstructed distance to the proposed fire department connection, which is less than the maximum 45 m required by the Ontario Building Code.

When calculating the required fire flow where municipal pipe sizing is affected, the Fire Underwriters Survey Method is to be used. Using the Fire Underwriters Survey Method, the required fire flow is calculated to be 11,000 L/min (183.3 L/s). Refer to calculations in Appendix A.

The City of Ottawa indicated that 250 L/s will be available at Connection 1 once the existing 150 mm Heatherington Road municipal watermain is upgraded to 250 mm. Refer to Appendix A. Therefore, there will be an adequate water supply for firefighting.

The aggregate flow of all contributing fire hydrants within 150 m of the building shall not be less than the required fire flow. The existing municipal Class AA fire hydrant discussed above can contribute 5,700 L/min (95 L/s). The next two closest existing municipal fire hydrants are Class AA and are within between 75 m and 150 m of the proposed building; one is located in front of 2920 Fairlea Crescent; and the other is located at the SE corner of the subject property. Each can contribute 3,800 L/min (63.3 L/s). The aggregate flow of the three contributing fire hydrants is 13,300 L/min (221.7 L/s), which is greater than the required fire flow of 11,000 L/min (183.3 L/s).

2.2 DOMESTIC WATER SUPPLY

Based on the 31 – 1 bedroom apartment units and 14 – 2 bedroom apartment units, the average daily demand is calculated to be 0.2 L/s, the maximum daily demand is calculated to be 1.9 L/s and the maximum hourly demand is calculated to be 2.8 L/s. Refer to calculations in Appendix A.

A 150 mm water service connecting to the upgraded 250 mm Heatherington Road municipal watermain is proposed to service the sprinkler system. The same 150 mm water service will provide an adequate domestic water supply.

3.0 SANITARY SERVICING

Based on the 31 – 1 bedroom apartment units and 14 – 2 bedroom apartment units, the post-development sanitary flow rate is calculated to be 0.82 L/s. A 150 mm sanitary sewer service at 2% slope (21.54 L/s capacity) and private sanitary sewer at 0.48% slope (10.55 L/s capacity) are proposed to service the development. At the design flow rates the private sanitary sewer system will only be at up to 8% capacity. The proposed 150 mm private sanitary sewer will connect to the existing 250 mm Heatherington Road municipal sanitary sewer, which at 0.3% slope has a capacity of 32.57 L/s. Refer to calculations in Appendix B. The post-development increase in flow is expected to have an acceptable impact on the 250 mm Heatherington Road municipal sanitary sewer.

4.0 STORMWATER MANAGEMENT

4.1 QUANTITY CONTROL

The stormwater quantity control criterion is to control the post-development 100-year peak flow rate to the pre-development 2-year peak flow rate using a calculated pre-development runoff coefficient not more than 0.50. It is calculated that the pre-development conditions reflect a 2-year runoff coefficient of 0.43. The 2-year runoff coefficients are increased by 25% to a maximum of 1.00 to calculate the 100-year runoff coefficient. It is calculated that the pre-development conditions reflect a 100-year runoff coefficient of 0.50. Using the Rational Method with a time of concentration of 10 minutes, the pre-development flow rates are calculated to be 46.72 L/s during the 100-year event and 17.41 L/s during the 2-year event. The Rational and Modified Rational Methods are used to calculate the post-development flow rates and corresponding storage volumes. Refer to calculations in Appendix C.

Drainage Area I (Uncontrolled Flow Off Site – 300 sq.m)

Areas to the east and south of the property will drain uncontrolled off site. The flow rates are calculated at a time of concentration of 10 minutes.

	100-Year Event	2-Year Event
Maximum Flow Rate	6.52 L/s	2.40 L/s

Drainage Area II (Roof – 940 sq.m)

The 4 roof drains are to be flow control type roof drains, which will restrict the flow of stormwater and cause it to pond on the roof. Roof drains are to be Watts RD-100 c/w a Watts Adjustable Accutrol Weir in the ½ open position and release 1.26 L/s at 150 mm (20 USgpm at 6”). The opening at the top of the flow control weir is to be a minimum 50 mm in diameter. A minimum of 6 scuppers each a minimum 450 mm wide are to be installed 150 mm above the roof drains. Refer to architectural for exact locations and details. The roof is to be designed to carry the load of water having a 50 mm depth at the scuppers (i.e. 200 mm depth at the roof drains). Refer to structural.

	100-Year Event	2-Year Event
Maximum Release Rate	4.93 L/s	3.70 L/s
Maximum Depth at Roof Drains	147 mm	97 mm
Maximum Volume Stored	35.42 cu.m	10.38 cu.m

Drainage Area III (650 sq.m)

An inlet control device (ICD) located in the outlet pipe of CB/MH-A4 will restrict the flow of stormwater and cause it to backup into the upstream infrastructure and pond above CB/MH-A1, CB-A2 and CB/MH-A4. The ICD will be a vortex style manufactured by Hydrovex or approved equivalent sized by the manufacturer for a release rate of 5.97 L/s at 1.29 m. It is determined that a 75 VHV-1 will restrict the maximum flow rate to 5.97 L/s at 1.29 m. Based on this orifice, the maximum flow rate during the 2-year event is calculated to be 5.77 L/s at 1.21 m.

	100-Year Event	2-Year Event
Maximum Release Rate	5.97 L/s	5.77 L/s
Maximum Water Elevation	87.39 m	87.31 m
Maximum Volume Stored	15.14 cu.m	2.91 cu.m

Summary

The maximum post-development release rate during the 100-year event is calculated to be 17.41 L/s, which is 63% less than the pre-development flow rate during the 100-year event and equal to the maximum allowable release rate. To achieve the maximum allowable release rate, a maximum storage volume of 50.55 cu.m is required and provided during the 100-year event. The maximum post-development release rate during the 2-year event is calculated to be 11.88 L/s, which is 32% less than the pre-development flow rate during the 2-year event. A maximum storage volume of 13.29 cu.m is required and provided during the 2-year event.

	100-Year Event	2-Year Event
Pre-Development Flow Rate	46.72 L/s	17.41 L/s
Maximum Allowable Release Rate	17.41 L/s	17.41 L/s
Maximum Release Rate	17.41 L/s	11.88 L/s
Maximum Volume Required	50.55 cu.m	13.29 cu.m
Maximum Volume Stored	50.55 cu.m	13.29 cu.m

4.2 QUALITY CONTROL

The stormwater quality control criterion is to provide an enhanced (80% TSS removal) level of protection. An oil grit separator manhole (OGS MH-A5) is proposed to be located downstream of the ICD. Calculations by the manufacturer indicate that the CDS PMSU-2015-4 OGS will remove 95% of total suspended solids. Refer to calculations in Appendix C.

An Erosion & Sediment Control Plan has been developed to be implemented during construction. Refer to drawing C-8 and C-9, and notes on drawing C-22.

- i. Sediment capture filter sock inserts are to be installed in all existing and proposed catch-basins and catch-basin/manholes adjacent to and within the site.
- ii. A silt fence barrier is to be installed along the perimeter of the site.
- iii. Any material deposited on the public road is to be removed.

4.3 STORM SERVICING

The peak unrestricted roof flow rate during the 2-year event is calculated to be 18.06 L/s. A 250 mm storm sewer service at 2% slope (84.10 L/s capacity) is proposed to service the building. At the peak unrestricted 2-year flow rate the storm sewer service would be at 21% capacity. The peak restricted roof flow rate during the 2-year event is calculated to be 3.70 L/s. At the peak restricted 2-year flow rate the storm sewer service will only be at 4% capacity. Refer to calculations in Appendix C. The proposed 250 mm storm sewer service will connect to the proposed private storm sewer system downstream of the ICD.

The peak unrestricted flow rate draining into the last sewer segment of the private storm sewer system during the 2-year event is calculated to be 26.71 L/s. A 250 mm storm sewer at 0.432% slope (39.09 L/s capacity) is proposed to connect to the existing 300 mm Heatherington Road municipal storm sewer, which at 0.55% slope has a capacity of 71.72 L/s. At the peak unrestricted 2-year flow rate the proposed 250 mm storm sewer would be at 68% capacity. The peak restricted flow rate draining into the last sewer

segment of the private storm sewer system during the 2-year event is calculated to be 9.47 L/s. At the peak restricted 2-year flow rate the proposed 250 mm storm sewer will only be at 24% capacity. Refer to calculations in Appendix C.

The rainwater leaders inside the building are to be constructed to withstand the pressure from a water column the height of the rainwater leader. Pressure tests are to be performed on the systems in accordance with the mechanical engineer's instructions.

The foundation drain will drain to a storm sump and be pumped to a storm drain. Refer to mechanical.

5.0 CONCLUSIONS

1. There will be an adequate water supply for firefighting once the existing 150 mm Heatherington Road municipal watermain is upgraded to 250 mm.
2. The post-development sanitary flow rates will be adequately handled by the proposed private sanitary sewer system.
3. The post-development increase in sanitary flow is expected to have an acceptable impact on the existing municipal sanitary sewer.
4. The maximum post-development release rate during the 100-year event will be equal to the maximum allowable release rate.
5. The proposed OGS will provide an enhanced (80% TSS removal) level of protection.
6. An Erosion & Sediment Control Plan has been developed to be implemented during construction.
7. The peak unrestricted flow rates during the 2-year event will be adequately handled by the proposed private storm sewer system.
8. The rainwater leaders inside the building are to be constructed to withstand the pressure from a water column the height of the rainwater leader. Pressure tests are to be performed on the systems in accordance with the mechanical engineer's instructions.

Prepared by D.B. Gray Engineering Inc.



APPENDIX A

WATER SERVICING

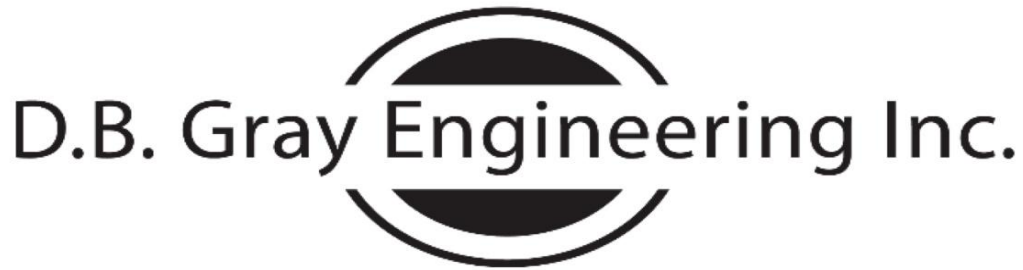

Stormwater Management - Grading & Drainage - Storm & Sanitary Sewers - Watermains

700 Long Point Circle
Ottawa, Ontario K1T 4E9

613-425-8044
d.gray@dbgrayengineering.com

March 5, 2026

1770 Heatherington Road
4-Storey Apartment Building 1
Ottawa, Ontario

FIRE FLOW CALCULATIONS FUS Method

RFF = Required Fire Flow in litres per minute
= $220CA^{0.5}$

C = Construction Coefficient related to the type of construction of the building
= 1.5 Type V Wood Frame Construction

A = Total Effective Floor Area in square meters of the building

4th Floor:	940	sq.m
3rd Floor:	940	sq.m
2nd Floor:	940	sq.m
1st Floor:	940	sq.m

3,760 sq.m

RFF = 20,235 L/min
= 20,000 L/min (rounded to nearest 1,000 L/min)

Occupancy and Contents Adjustment Factor
-15% Limited Combustible Contents

= -3,000 L/min Occupancy and Contents Adjustment Factor

RFF = 17,000 L/min

Automatic Sprinkler Protection Credit

- 30% Sprinkler system designed, installed and maintained in accordance with NFPA standards
- 10% Standard water supply for both the sprinkler system and fire department hose lines
- 10% Fully supervised sprinkler system

= 8,500 L/min Automatic Sprinkler Protection Credit

Exposure Adjustment Charge

Side	Charge	Distance	Construction	Length	Storeys	Factor
North	6%	10.1 m to 20 m	Type III	23	1	23
East	0%	over 30 m				
South	0%	over 30 m				
West	11%	10.1 m to 20 m	Type V	16	2	32

17% Exposure Adjustment Charge

= 2,890 L/min Exposure Adjustment Charge

RFF = 11,390 L/min

= 11,000 L/min (rounded to nearest 1,000 L/min)

= 183.3 L/s

WATER SUPPLY
FOR
PUBLIC FIRE PROTECTION

*A Guide to Recommended Practice
in Canada*

2020



Fire Underwriters Survey

Automatic Sprinkler Protection

The required fire flow may be reduced by up to 50 percent for complete Automatic Sprinkler Protection depending upon adequacy of the system. Where only part of a building is protected by Automatic Sprinkler Protection, credit should be interpolated by determining the percentage of the Total Floor Area being protected by the automatic sprinkler system.

To be able to apply the full 50 percent reduction, the following areas should be reviewed to determine the appropriate level of credit for having Automatic Sprinkler Protection as per the table below:

Table 4 Sprinkler Credits

Automatic Sprinkler System Design	Credit	
	With complete building coverage	With partial building coverage of X%
Automatic sprinkler protection designed and installed in accordance with NFPA 13	30%	$30\% \times \text{Percentage of Total Floor Area Served by Sprinkler System}$
Water supply is standard for both the system and Fire Department hose lines	10%	$10\% \times \text{Percentage of Total Floor Area Served by Sprinkler System}$
Fully supervised system	10%	$10\% \times \text{Percentage of Total Floor Area Served by Sprinkler System}$

Automatic Sprinkler Protection Designed and Installed in Accordance with Applicable NFPA Standards (30%)

The initial credit for Automatic Sprinkler Protection is a maximum of 30% based on the system being designed and installed in accordance with the applicable criteria of NFPA 13, *Standard for Installation of Sprinkler Systems*, NFPA 13R, *Standard for the Installation of Sprinkler Systems in Low-Rise Residential Occupancies*, or NFPA 13D, *Standard for the Installation of Sprinkler Systems in One- and Two-Family Dwellings and Manufactured Homes* and being maintained in accordance with the applicable criteria of NFPA 25, *Standard for the Inspections, Testing and Maintenance of Water-Based Fire* (see Recognition of Automatic Sprinkler Protection).

Water Supply is Standard for both the Sprinkler System and Fire Department Hose Lines (10%)

To qualify to apply an additional 10% reduction, a water supply that is standard for both the sprinkler system and fire department hose lines is required, to qualify the following conditions should be satisfied:

- a) Sprinkler system is supplied by a pressurized water supply system (public or private) that is designed and built with no major non-conformance issues (i.e. water supply system is designed in accordance with Part 1 of the Water Supply for Public Fire Protection to qualify for fire insurance grading recognition).
- b) Calculated demand for maximum sprinkler design area operation in addition to hose stream requirements are below the available water supply curve (at the corresponding flow rate and pressure). An appropriate safety margin is used to take into account the difference between the available water supply curve at the time of hydrant flow testing as compared to the available water supply curve during Maximum Day Demand.

- c) Volume of water available is adequate for the total flow rate including the maximum sprinkler design area operation plus required hose streams plus Maximum Day Demand for the full duration of the design fire event.
- d) Residual pressure at all points in the water supply system can be maintained at not less than 150 kPa during the flowing of the sprinkler and required hose streams (plus Maximum Day Demand).

Fully Supervised System (10%)

To qualify to apply an additional 10% reduction, an automatic sprinkler system should be fully supervised. The purpose of the supervisory signal is to ensure that malfunctions of the automatic sprinkler system will be discovered and corrected promptly, while the water flow alarm serves to notify emergency services of the fire as soon as the automatic sprinkler system activates.

- a distinctive supervisory signal to indicate conditions that could impair the satisfactory operation of the sprinkler system (a fault alarm), which is to sound and be displayed, either at a location within the building that is constantly attended by qualified personnel (such as a security room), or at an approved remotely located receiving facility (such as a monitoring facility of the sprinkler system manufacturer); and
- a water flow alarm to indicate that the sprinkler system has been activated, which is to be transmitted to an approved, proprietary alarm-receiving facility, a remote station, a central station or the fire department.

Additional Reductions for Community Level Automatic Sprinkler Protection of Area

Buildings located within communities or subdivisions that are completely sprinkler protected may apply up to a maximum additional 25% reduction in required fire flows beyond the normal maximum of 50% reduction for sprinkler protection of an individual building.

This additional reduction may be applied where all the following conditions are met:

- a) the community has a bylaw requiring all buildings that may be built within 30 m of the subject building to be fully sprinkler protected. I.e. future development will not create unsprinklered buildings within 30 m of the subject building, and
- b) all buildings within 30 meters of the subject building are fully sprinkler protected with systems that are designed and installed in accordance with the applicable criteria of NFPA 13, *Standard for Installation of Sprinkler Systems*, NFPA 13R, *Standard for the Installation of Sprinkler Systems in Low-Rise Residential Occupancies*, or NFPA 13D, *Standard for the Installation of Sprinkler Systems in One- and Two-Family Dwellings and Manufactured Homes*, and
- c) the community has in place a Fire Prevention Program that provides a system of ensuring that installed fire sprinkler systems are inspected, tested, and maintained in accordance with NFPA 25: *Standard for the Inspection, Testing, and Maintenance of Water-Based Fire Protection Systems*, and
- d) the community maintains the pressure and flow rate requirements for fire sprinkler installations. I.e. the community does not make significant reductions to the operating pressures or flows across the distribution network.

Adjustment of Sprinkler Reductions for Community Level Oversight of Sprinkler Maintenance, Testing and Water Supply Requirements

The reduction in required fire flows for sprinkler protection may be reduced or eliminated if

- a) the community does not have a Fire Prevention Program that provides a system of ensuring that installed fire sprinkler systems are inspected, tested, and maintained in accordance with NFPA 25: *Standard for the Inspection, Testing, and Maintenance of Water-Based Fire Protection Systems*, or
- b) the community does not maintain the pressure and flow rate requirements for fire sprinkler installations, or otherwise allows the flow rates and pressure levels that were available during sprinkler system design to significantly degrade, increasing the probability of inadequate water supply for effective sprinkler operation.

Recognition of Automatic Sprinkler Protection

A property should be considered as “sprinkler protected” for the purposes of determining required fire flows, if the building has an automatic fire sprinkler system:

- designed and installed throughout all areas in accordance with NFPA 13, *Standard for Installation of Sprinkler Systems*, and maintained in accordance with the NFPA 25, *Standard for the Inspections, Testing and Maintenance of Water-Based Fire Protection Systems*, and
- supplied by water infrastructure capable of meeting all pressure and flow requirements of the sprinkler system concurrently with Max Day Demand (if connected to a domestic system)

Evidence of the sprinkler system design, installation should be acquired from the party responsible for the building (the owner, building engineer or property manager) or the municipal fire prevention office.

On site, the sprinkler system should carry test tags verifying that a qualified person has conducted tests including:

- flushing and hydrostatic tests of both the underground and overhead piping in accordance with NFPA 13;
- full-flow main drain test within the previous 48 months.
- dry-pipe trip test (if applicable) conducted within the last 48 months
- fire-pump test (if applicable) conducted within the last 48 months

Items of Note for Sprinkler Systems

- i. It is important to note that installation of automatic sprinkler systems provides a highly effective and reliable system of fire protection however, this does not preclude the need for manual fire flows entirely as some fires, for various reasons, grow beyond the capability of sprinkler protection to be effective, and in these cases, manual fire fighting intervention is required.

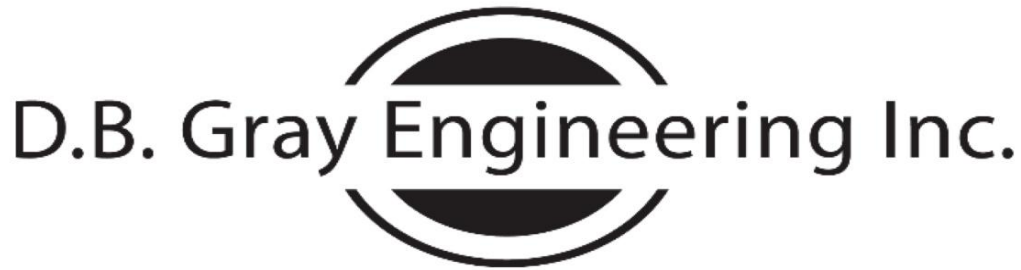

Stormwater Management - Grading & Drainage - Storm & Sanitary Sewers - Watermains

700 Long Point Circle
Ottawa, Ontario K1T 4E9

613-425-8044
d.gray@dbgrayengineering.com

March 5, 2026

1770 Heatherington Road
4-Storey Apartment Building 1
Ottawa, Ontario

WATER DEMAND CALCULATIONS

	Number of Units	Persons per Unit	Population
1 Bedroom:	31	1.4	43.4
2 Bedroom:	14	2.1	29.4
3 Bedroom:	0	3.1	0
Average:	0	1.8	0
Total:	45		72.8

Average Daily Demand: 280 L/capita/day
 14.2 L/min 0.2 L/s 3.7 USgpm

Maximum Daily Demand: 7.9 (Peaking factor for a population of 72.8 interpolated from MOE Design Guidelines for Drinking Water Systems Table 3-3)
 111.3 L/min 1.9 L/s 29.4 USgpm

Maximum Hourly Demand: 11.8 (Peaking factor for a population of 72.8 interpolated from MOE Design Guidelines for Drinking Water Systems Table 3-3)
 167.6 L/min 2.8 L/s 44.3 USgpm

Boundary Conditions for 1770 Heatherington Road

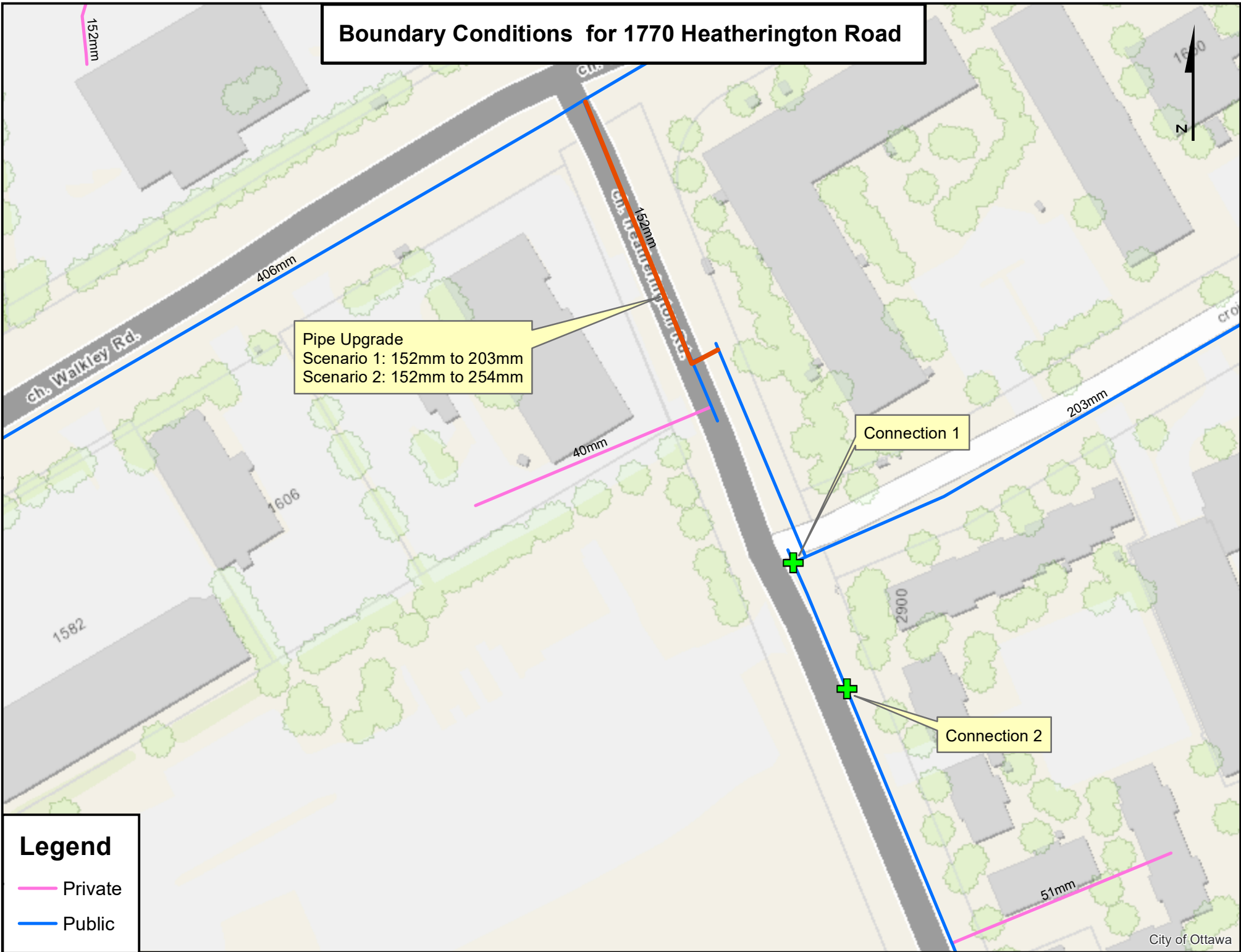

Legend

- Private
- Public

APPENDIX B

SANITARY SERVICING

APPENDIX C

STORMWATER MANAGEMENT

SUMMARY TABLES

100-YEAR EVENT					
Drainage Area	Pre-Development Flow Rate (L/s)	Maximum Allowable Release Rate (L/s)	Maximum Release Rate (L/s)	Maximum Volume Required (cu.m)	Maximum Volume Stored (cu.m)
AREA I (Uncontrolled Flow Off Site)	-	-	6.52	-	-
AREA II (Roof)	-	-	4.93	35.42	35.42
AREA III	-	-	5.97	15.14	15.14
TOTAL	46.72	17.41	17.41	50.55	50.55

2-YEAR EVENT					
Drainage Area	Pre-Development Flow Rate (L/s)	Maximum Allowable Release Rate (L/s)	Maximum Release Rate (L/s)	Maximum Volume Required (cu.m)	Maximum Volume Stored (cu.m)
AREA I (Uncontrolled Flow Off Site)	-	-	2.40	-	-
AREA II (Roof)	-	-	3.70	10.38	10.38
AREA III	-	-	5.77	2.91	2.91
TOTAL	17.41	17.41	11.88	13.29	13.29

1770 Heatherington Road
 4-Storey Apartment Building 1
 Ottawa, Ontario

STORMWATER MANAGEMENT CALCULATIONS
 Modified Rational Method

PRE-DEVELOPMENT CONDITIONS

100-YEAR EVENT

			C
Roof Area:	325	sq.m	1.00
Hard Area:	300	sq.m	1.00
Gravel Area:	0	sq.m	1.00
Soft Area:	<u>1,265</u>	<u>sq.m</u>	<u>0.25</u>
Total Catchment Area:	1,890	sq.m	0.50
Area (A):	1,890	sq.m	
Time of Concentration:	10	min	
Rainfall Intensity (i):	179	mm/hr	
Runoff Coefficient (C):	0.50		
100-Year Pre-Development Flow Rate (2.78AiC):	46.72	L/s	

2-YEAR EVENT

			C
Roof Area:	325	sq.m	0.90
Hard Area:	300	sq.m	0.90
Gravel Area:	0	sq.m	0.80
Soft Area:	<u>1,265</u>	<u>sq.m</u>	<u>0.20</u>
Total Catchment Area:	1,890	sq.m	0.43
Area (A):	1,890	sq.m	
Time of Concentration:	10	min	
Rainfall Intensity (i):	77	mm/hr	
Runoff Coeficient (C):	0.43		
2-Year Pre-Development Flow Rate (2.78AiC):	17.41	L/s	

100-YEAR EVENT

DRAINAGE AREA I (Uncontrolled Flow Off Site)

(100-YEAR EVENT)

			C
Roof Area:	0	sq.m	1.00
Hard Area:	75	sq.m	1.00
Gravel Area:	0	sq.m	1.00
Soft Area:	225	sq.m	0.25
	<hr/>		<hr/>
Total Catchment Area:	300	sq.m	0.44
Area (A):	300	sq.m	
Time of Concentration:	10	min	
Rainfall Intensity (i):	179	mm/hr	
Runoff Coefficient (C):	0.44		
Flow Rate (2.78AiC):	6.52	L/s	

DRAINAGE AREA II (Roof)

(100-YEAR EVENT)

Total Catchment Area:	940	sq.m	C	1.00
No. of Roof Drains:	4			
Wier Opening:	1/2			
Depth at Roof Drains:	147	mm		
Maximum Release Rate:	4.93	L/s	Pond Area:	724 sq.m
			Maximum Volume Stored:	35.42 cu.m
			Maximum Volume Required:	35.42 cu.m

Time (min)	i (mm/hr)	2.78AiC (L/s)	Release Rate (L/s)	Stored Rate (L/s)	Required Storage Volume (cu.m)
10	179	46.66	4.93	41.73	25.04
15	143	37.34	4.93	32.41	29.17
20	120	31.35	4.93	26.42	31.70
25	104	27.14	4.93	22.21	33.31
30	92	24.01	4.93	19.08	34.34
35	83	21.58	4.93	16.65	34.97
40	75	19.64	4.93	14.71	35.30
45	69	18.04	4.93	13.12	35.42
50	64	16.71	4.93	11.79	35.36
55	60	15.58	4.93	10.65	35.16
60	56	14.61	4.93	9.68	34.84
65	53	13.76	4.93	8.83	34.44
70	50	13.01	4.93	8.08	33.95
75	47	12.35	4.93	7.42	33.40
80	45	11.76	4.93	6.83	32.78
85	43	11.22	4.93	6.30	32.12
90	41	10.74	4.93	5.82	31.41
95	39	10.31	4.93	5.38	30.65
100	38	9.90	4.93	4.98	29.86
105	36	9.54	4.93	4.61	29.04
110	35	9.20	4.93	4.27	28.19
115	34	8.89	4.93	3.96	27.32
120	33	8.60	4.93	3.67	26.41
125	32	8.33	4.93	3.40	25.49
130	31	8.07	4.93	3.15	24.55
135	30	7.84	4.93	2.91	23.58
140	29	7.62	4.93	2.69	22.60
145	28	7.41	4.93	2.48	21.60

DRAINAGE AREA III

(100-YEAR EVENT)

			C
Roof Area:	0	sq.m	1.00
Hard Area:	525	sq.m	1.00
Gravel Area:	0	sq.m	1.00
Soft Area:	125	sq.m	0.25

Total Catchment Area:	650	sq.m	0.86
-----------------------	-----	------	------

Water Elevation: 87.39 m

Head: 1.29 m

Centroid of ICD Orifice: 86.10 m

Invert of Outlet Pipe of CB/MH-A4: 86.06 m

Orifice Diameter: 75 mm

Orifice Area: 4,418 sq.mm

Discharge Coefficient: 0.27

Maximum Release Rate: 5.97 L/s

CB/MH	Top Area	Depth	Volume	
CB/MH-A1	204	0.20	13.69	cu.m
CB/MH-A4	31	0.14	1.45	cu.m

Maximum Volume Stored: 15.14 cu.m

Maximum Volume Required: 15.14 cu.m

DRAINAGE AREA III (Continued)

(100-YEAR EVENT)

Time (min)	i (mm/hr)	2.78AiC (L/s)	Release Rate (L/s)	Stored Rate (L/s)	Required Storage Volume (cu.m)
10	179	27.61	5.97	21.65	12.99
15	143	22.10	5.97	16.13	14.52
20	120	18.55	5.97	12.58	15.10
25	104	16.06	5.97	10.09	15.14
30	92	14.21	5.97	8.24	14.83
35	83	12.77	5.97	6.80	14.29
40	75	11.62	5.97	5.65	13.57
45	69	10.68	5.97	4.71	12.72
50	64	9.89	5.97	3.92	11.77
55	60	9.22	5.97	3.25	10.74
60	56	8.64	5.97	2.68	9.64
65	53	8.14	5.97	2.17	8.48
70	50	7.70	5.97	1.73	7.28
75	47	7.31	5.97	1.34	6.04
80	45	6.96	5.97	0.99	4.76
85	43	6.64	5.97	0.68	3.45
90	41	6.36	5.97	0.39	2.11
95	39	6.10	5.97	0.13	0.75
100	38	5.86	5.86	0.00	0.00
105	36	5.64	5.64	0.00	0.00
110	35	5.44	5.44	0.00	0.00
115	34	5.26	5.26	0.00	0.00
120	33	5.09	5.09	0.00	0.00
125	32	4.93	4.93	0.00	0.00
130	31	4.78	4.78	0.00	0.00
135	30	4.64	4.64	0.00	0.00
140	29	4.51	4.51	0.00	0.00
145	28	4.39	4.39	0.00	0.00

2-YEAR EVENT

DRAINAGE AREA I (Uncontrolled Flow Off Site)

(2-YEAR EVENT)

			C
Roof Area:	0	sq.m	0.90
Hard Area:	75	sq.m	0.90
Gravel Area:	0	sq.m	0.80
Soft Area:	<u>225</u>	<u>sq.m</u>	<u>0.20</u>
Total Catchment Area:	300	sq.m	0.38
Area (A):	300	sq.m	
Time of Concentration:	10	min	
Rainfall Intensity (i):	77	mm/hr	
Runoff Coefficient (C):	0.38		
Flow Rate (2.78AiC):	2.40	L/s	

DRAINAGE AREA II (Roof)

(2-YEAR EVENT)

Total Catchment Area:	940	sq.m	C	0.90
No. of Roof Drains:	4			
Wier Opening:	1/2			
Depth at Roof Drains:	97	mm		
Maximum Release Rate:	3.70	L/s	Pond Area:	319 sq.m
			Maximum Volume Stored:	10.38 cu.m
			Maximum Volume Required:	10.38 cu.m

Time (min)	i (mm/hr)	2.78AiC (L/s)	Release Rate (L/s)	Stored Rate (L/s)	Required Storage Volume (cu.m)
10	77	18.06	3.70	14.36	8.62
15	62	14.53	3.70	10.82	9.74
20	52	12.24	3.70	8.53	10.24
25	45	10.62	3.70	6.92	10.38
30	40	9.42	3.70	5.71	10.29
35	36	8.48	3.70	4.78	10.03
40	33	7.73	3.70	4.03	9.66
45	30	7.11	3.70	3.41	9.20
50	28	6.59	3.70	2.89	8.68
55	26	6.15	3.70	2.45	8.09
60	25	5.78	3.70	2.07	7.46
65	23	5.44	3.70	1.74	6.79
70	22	5.15	3.70	1.45	6.09
75	21	4.90	3.70	1.19	5.36
80	20	4.66	3.70	0.96	4.61
85	19	4.46	3.70	0.75	3.84
90	18	4.27	3.70	0.56	3.04
95	17	4.10	3.70	0.39	2.24
100	17	3.94	3.70	0.24	1.41
105	16	3.79	3.70	0.09	0.57
110	16	3.66	3.66	0.00	0.00
115	15	3.54	3.54	0.00	0.00
120	15	3.42	3.42	0.00	0.00
125	14	3.32	3.32	0.00	0.00
130	14	3.22	3.22	0.00	0.00
135	13	3.13	3.13	0.00	0.00
140	13	3.04	3.04	0.00	0.00
145	13	2.96	2.96	0.00	0.00

DRAINAGE AREA III

(2-YEAR EVENT)

			C
Roof Area:	0	sq.m	0.90
Hard Area:	525	sq.m	0.90
Gravel Area:	0	sq.m	0.80
Soft Area:	<u>125</u>	<u>sq.m</u>	<u>0.20</u>

Total Catchment Area: 650 sq.m 0.77

Water Elevation: 87.31 m

Head: 1.21 m

Centroid of ICD Orifice: 86.10 m

Invert of Outlet Pipe of CB/MH-A4: 86.06 m

Orifice Diameter: 75 mm

Orifice Area: 4,418 sq.mm

Discharge Coefficient: 0.27

Maximum Release Rate: 5.77 L/s

CB/MH	Top Area	Depth	Volume	
CB/MH-A1	71	0.12	2.81	cu.m
CB/MH-A4	5	0.06	0.10	cu.m

Maximum Volume Stored: 2.91 cu.m

Maximum Volume Required: 2.91 cu.m

DRAINAGE AREA III (Continued)

(2-YEAR EVENT)

Time (min)	i (mm/hr)	2.78AiC (L/s)	Release Rate (L/s)	Stored Rate (L/s)	Required Storage Volume (cu.m)
10	77	10.62	5.77	4.85	2.91
15	62	8.54	5.77	2.77	2.49
20	52	7.20	5.77	1.42	1.71
25	45	6.25	5.77	0.47	0.71
30	40	5.54	5.54	0.00	0.00
35	36	4.99	4.99	0.00	0.00
40	33	4.55	4.55	0.00	0.00
45	30	4.18	4.18	0.00	0.00
50	28	3.88	3.88	0.00	0.00
55	26	3.62	3.62	0.00	0.00
60	25	3.40	3.40	0.00	0.00
65	23	3.20	3.20	0.00	0.00
70	22	3.03	3.03	0.00	0.00
75	21	2.88	2.88	0.00	0.00
80	20	2.74	2.74	0.00	0.00
85	19	2.62	2.62	0.00	0.00
90	18	2.51	2.51	0.00	0.00
95	17	2.41	2.41	0.00	0.00
100	17	2.32	2.32	0.00	0.00
105	16	2.23	2.23	0.00	0.00
110	16	2.15	2.15	0.00	0.00
115	15	2.08	2.08	0.00	0.00
120	15	2.01	2.01	0.00	0.00
125	14	1.95	1.95	0.00	0.00
130	14	1.89	1.89	0.00	0.00
135	13	1.84	1.84	0.00	0.00
140	13	1.79	1.79	0.00	0.00
145	13	1.74	1.74	0.00	0.00

**CDS ESTIMATED NET ANNUAL TSS LOAD REDUCTION
BASED ON THE RATIONAL RAINFALL METHOD
AND A FINE PARTICLE SIZE DISTRIBUTION**



Echelon Environmental

55 Albert Street, Suite #200 | Markham, ON, L3P 2T4

www.echelonenvironmental.ca

info@echelonenvironmental.ca

[905-948-0000](tel:905-948-0000)

Project Name: 1770 Heatherington Rd.	Engineer: D. B. Gray Engineering
Location: Ottawa, ON	Contact: Ryan Faith
OGS ID: Lot 1	Report Date: 4-Mar-26

Area: 0.159 ha	Rainfall Station # 215
C Value: 0.85	Particle Size Distribution FINE
CDS Model: PMSU2015-4	CDS Treatment Capacity: 20 l/s

<u>Rainfall Intensity¹</u> <u>(mm/hr)</u>	<u>Percent Rainfall Volume¹</u>	<u>Cumulative Rainfall Volume</u>	<u>Total Flowrate (l/s)</u>	<u>Treated Flowrate (l/s)</u>	<u>Operating Rate (%)</u>	<u>Removal Efficiency (%)</u>	<u>Incremental Removal (%)</u>
0.5	9.2%	9.2%	0.2	0.2	0.9	96.6	8.9
1.0	10.6%	19.8%	0.4	0.4	1.9	96.4	10.2
1.5	9.9%	29.7%	0.6	0.6	2.8	96.2	9.5
2.0	8.4%	38.1%	0.7	0.7	3.7	96.1	8.0
2.5	7.7%	45.8%	0.9	0.9	4.6	95.9	7.4
3.0	5.9%	51.7%	1.1	1.1	5.6	95.7	5.7
3.5	4.4%	56.1%	1.3	1.3	6.5	95.5	4.2
4.0	4.7%	60.7%	1.5	1.5	7.4	95.3	4.4
4.5	3.3%	64.0%	1.7	1.7	8.4	95.1	3.2
5.0	3.0%	67.1%	1.9	1.9	9.3	94.9	2.9
6.0	5.4%	72.4%	2.2	2.2	11.1	94.5	5.1
7.0	4.4%	76.8%	2.6	2.6	13.0	94.2	4.1
8.0	3.5%	80.3%	3.0	3.0	14.9	93.8	3.3
9.0	2.8%	83.2%	3.4	3.4	16.7	93.4	2.6
10.0	2.2%	85.3%	3.7	3.7	18.6	93.0	2.0
15.0	7.0%	92.3%	5.6	5.6	27.9	91.1	6.4
20.0	4.5%	96.9%	7.5	7.5	37.2	89.2	4.1
25.0	1.4%	98.3%	9.3	9.3	46.4	87.3	1.3
30.0	0.7%	99.0%	11.2	11.2	55.7	85.4	0.6
35.0	0.5%	99.5%	13.1	13.1	65.0	83.5	0.4
40.0	0.5%	100.0%	14.9	14.9	74.3	81.6	0.4
45.0	0.0%	100.0%	16.8	16.8	83.6	79.7	0.0
50.0	0.0%	100.0%	18.7	18.7	92.9	77.8	0.0

Predicted Net Annual TSS Removal Efficiency = 95%

Predicted Annual Rainfall Treated = 99%

1 - Based on 42 years of hourly rainfall data from Canadian Station 6105976, Ottawa ON

2 - CDS Efficiency based on testing conducted at the University of Central Florida

3 - CDS design flowrate and scaling based on standard manufacturer model & product specifications

CDS PMSU 2015-4-C DESIGN NOTES

THE STANDARD CDS PMSU 2015-4-C CONFIGURATION IS SHOWN.
 ANTI-BUOYANCY SLAB MAY BE INCLUDED (NOT SHOWN).
 SUMP DEPTH SHOWN IS TYPICAL, CAN BE EXTENDED AS REQUIRED.
 HYDRAULIC CHARACTERISTICS VARY BASED ON PIPE SIZE, MATERIAL, AND CDS UNIT SELECTION. FOR CUSTOM HYDRAULIC ANALYSIS PLEASE CONTACT ECHELON ENVIRONMENTAL.
 FOR SITE SPECIFIC DRAWINGS PLEASE CONTACT ECHELON ENVIRONMENTAL.

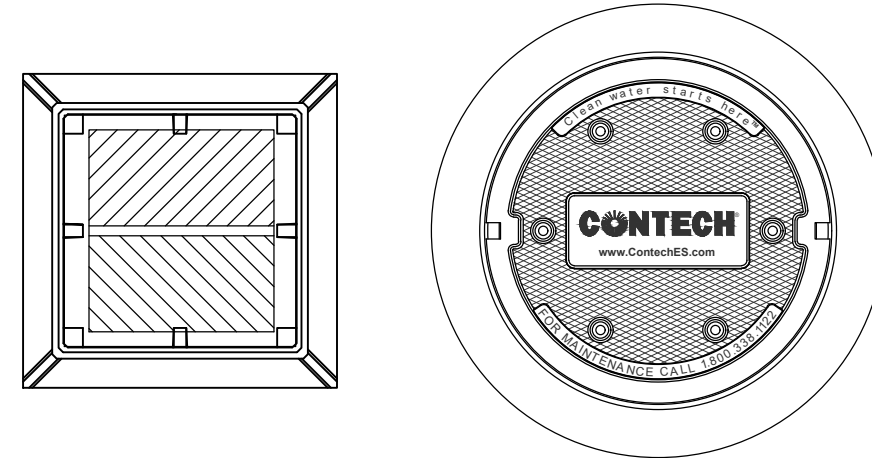
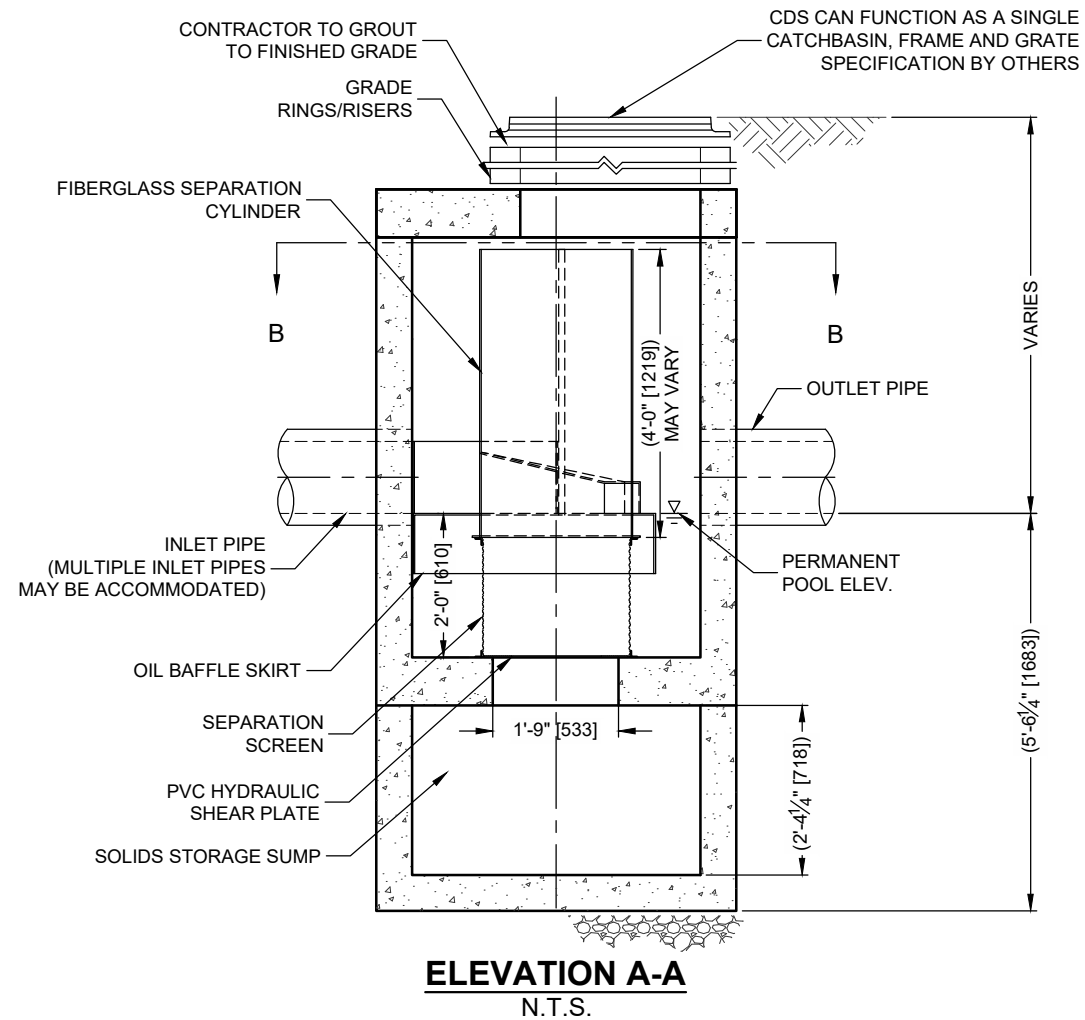
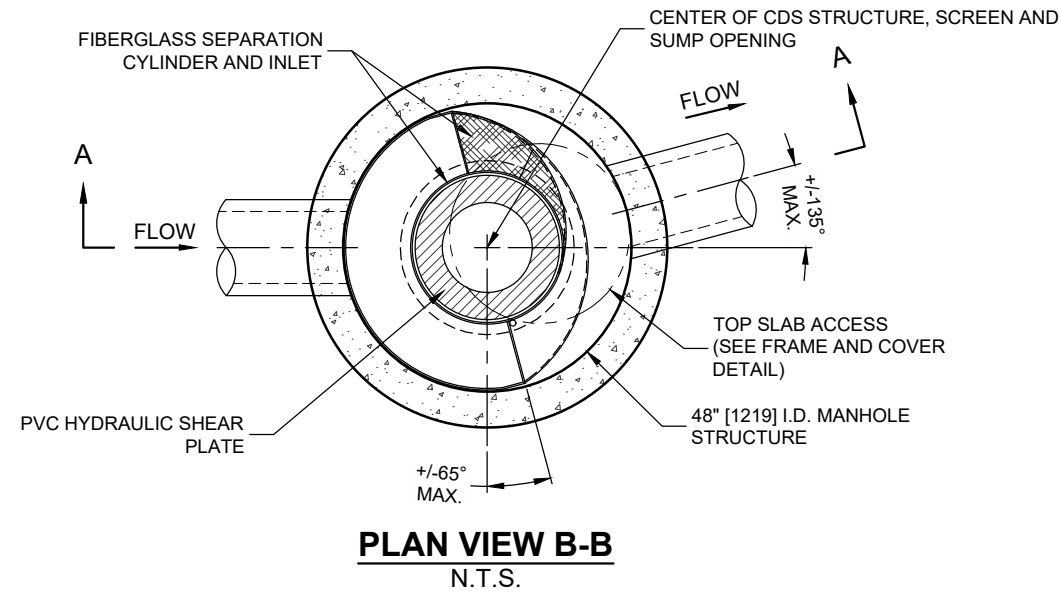

FRAME AND GRATE
(DIMENSIONS VARIES)
N.T.S.

FRAME AND COVER
(DIAMETER VARIES)
N.T.S.

GENERAL NOTES

1. CONTECH TO PROVIDE ALL MATERIALS UNLESS NOTED OTHERWISE.
2. DIMENSIONS MARKED WITH () ARE REFERENCE DIMENSIONS. ACTUAL DIMENSIONS MAY VARY.
3. FOR FABRICATION DRAWINGS WITH DETAILED STRUCTURE DIMENSIONS AND WEIGHTS, PLEASE CONTACT YOUR CONTECH ENGINEERED SOLUTIONS LLC REPRESENTATIVE. www.ContechES.com
4. CDS WATER QUALITY STRUCTURE SHALL BE IN ACCORDANCE WITH ALL DESIGN DATA AND INFORMATION CONTAINED IN THIS DRAWING.
5. STRUCTURE SHALL MEET AASHTO HS20 LOAD RATING, ASSUMING GROUNDWATER ELEVATION AT, OR BELOW, THE OUTLET PIPE INVERT ELEVATION. ENGINEER OF RECORD TO CONFIRM ACTUAL GROUNDWATER ELEVATION. CASTINGS SHALL MEET HS20 (AASHTO M 306) AND BE CAST WITH THE CONTECH LOGO.
6. IF REQUIRED, PVC HYDRAULIC SHEAR PLATE IS PLACED ON SHELF AT BOTTOM OF SCREEN CYLINDER. REMOVE AND REPLACE AS NECESSARY DURING MAINTENANCE CLEANING.

INSTALLATION NOTES

- A. ANY SUB-BASE, BACKFILL DEPTH, AND/OR ANTI-FLOTATION PROVISIONS ARE SITE-SPECIFIC DESIGN CONSIDERATIONS AND SHALL BE SPECIFIED BY ENGINEER OF RECORD.
- B. CONTRACTOR TO PROVIDE EQUIPMENT WITH SUFFICIENT LIFTING AND REACH CAPACITY TO LIFT AND SET THE CDS MANHOLE STRUCTURE (LIFTING CLUTCHES PROVIDED).
- C. CONTRACTOR TO ADD JOINT SEALANT BETWEEN ALL STRUCTURE SECTIONS, AND ASSEMBLE STRUCTURE.
- D. CONTRACTOR TO PROVIDE, INSTALL, AND GROUT PIPES. MATCH PIPE INVERTS WITH ELEVATIONS SHOWN.
- E. CONTRACTOR TO TAKE APPROPRIATE MEASURES TO ASSURE UNIT IS WATER TIGHT, HOLDING WATER TO FLOWLINE INVERT MINIMUM. IT IS SUGGESTED THAT ALL JOINTS BELOW PIPE INVERTS ARE GROUTED.

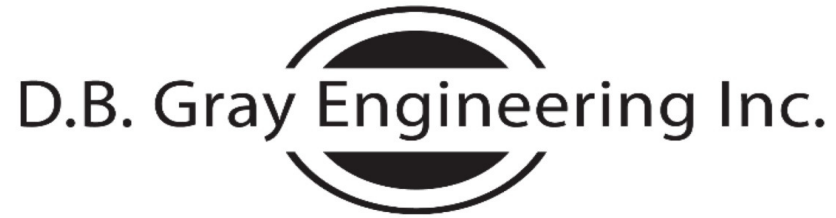

STORM SEWER CALCULATIONS

Rational Method

2-YEAR EVENT

Stormwater Management - Grading & Drainage - Storm & Sanitary Sewers - Watermains

700 Long Point Circle
Ottawa, Ontario K1T 4E9

613-425-8044
d.gray@dbgrayengineering.com

Project: 1770 Heatherington Road
4-Storey Apartment Building 1
Ottawa, Ontario

Date: March 5, 2026

Manning's Roughness Coefficient: 0.013

Location		Individual				Cumulative				Sewer Data									
		Roof C = 0.90 (ha)	Hard C = 0.90 (ha)	Gravel C = 0.80 (ha)	Soft C = 0.20 (ha)	2.78AC	2.78AC	Time (min)	Rainfall Intensity (mm/hr)	Q Flow Rate (L/s)	Length (m)	Nominal Diameter (mm)	Actual Diameter (mm)	Slope (%)	Velocity (m/s)	Q _{Full} Capacity (L/s)	Time (min)	Q / Q _{Full}	
From	To																		
CB/MH-A1	MH-A3		0.0325		0.0075	0.0855	0.0855	10.00	77	6.57	18.7	250	250	0.432	0.80	39.09	0.39	17%	
CB-A2	MH-A3		0.0050			0.0125	0.0125	10.00	77	0.96	2	250	250	0.432	0.80	39.09	0.04	2%	
MH-A3	CB/MH-A4					0.0000	0.0980	10.39	75	7.38	14.5	250	250	0.432	0.80	39.09	0.30	19%	
Roof Drains	CB/MH-A4	0.0940				0.2352	0.2352	10.00	77	18.06	2.9	250	250	2	1.71	84.10	0.03	21%	
							Flow through flow control roof drains:			3.70	2.9	250	250	2	1.71	84.10	0.03	4%	
CB/MH-A4	MH-A5		0.0150		0.0050	0.0403	0.3735	10.69	74	27.73	38.1	250	250	0.432	0.80	39.09	0.80	71%	
							Restricted upstream flow:			9.47	38.1	250	250	0.432	0.80	39.09	0.80	24%	
MH-A5	ST MH-A					0.0000	0.3735	11.49	72	26.71	14.8	250	250	0.432	0.80	39.09	0.31	68%	
							Restricted upstream flow:			9.47	14.8	250	250	0.432	0.80	39.09	0.31	24%	
Existing 300 mm Heatherington Road Municipal Storm Sewer:											300	300	0.55	1.01	71.72				