

PLAN VIEW

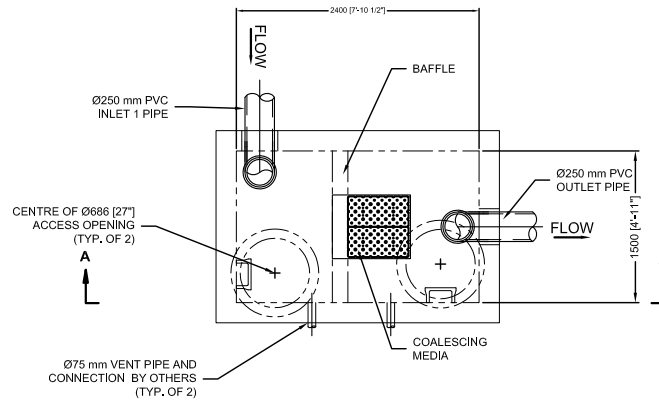

SECTION A-A

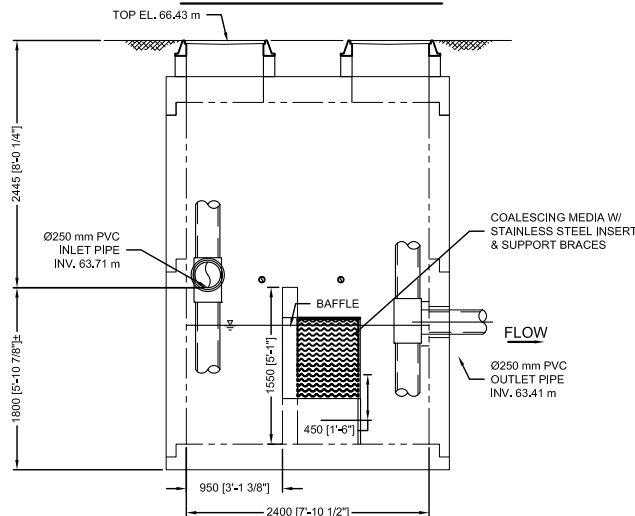

GENERAL NOTES:

- | | |
|------------------------------------------------------------------------------------------------------------------------------------------------------------------------------------------------------------------------------------------------------------------------------------------------------------------------------------------------------------------------------------------------------------------------------------------------------------------|-----------------------------------------------------------------------------------------------------------------------------------------------------------------------------------------------------------------------------------------------------------------------------------------------------------------------------------------------------------------------------------------------------------------------------------------------------|
| <p>A. OIL WATER SEPARATOR MANUFACTURED TO MEET CHBDC CL-625 ONT.</p> <p>B. UNIT DIMENSIONS VARIES: PENDING FINAL DESIGN.</p> <p>C. UNIT C/W INLET/OUTLET CORING AS SHOWN. PIPE CONFIGURATION MAY VARY.</p> <p>D. UNIT C/W 2-Ø686 mm OPENINGS FOR ACCESS AS SHOWN.</p> <p>E. UNIT C/W LIFTING INSERTS AS REQUIRED.</p> <p>F. UNIT C/W HOLLOW ALUMINUM STEPS AS PER OPSD 405.010.</p> <p>G. CONTRACTOR TO CONNECT PIPE(S) TO PIPE TEE(S) (SUPPLIED BY OTHERS).</p> | <p>H. CONTRACTOR TO GROUT ALL INTERIOR EDGES AND JOINTS.</p> <p>I. DESIGN CAN BE MODIFIED FOR SPECIFIC APPLICATIONS, PLEASE CONTACT ECHELON ENVIRONMENTAL.</p> <p>J. EST. HEAVIEST LIFT: 12 TONNES</p> <p>K. STANDARD DESIGN PARAMETERS:</p> <ul style="list-style-type: none"> • TEMPERATURE: 0.0°C • OIL S.G.: 0.85 • INFLUENT OIL: 100 mg/L • EFFLUENT OIL: 10-15 mg/L (AS PER MUNICIPAL REQUIREMENTS) |
|------------------------------------------------------------------------------------------------------------------------------------------------------------------------------------------------------------------------------------------------------------------------------------------------------------------------------------------------------------------------------------------------------------------------------------------------------------------|-----------------------------------------------------------------------------------------------------------------------------------------------------------------------------------------------------------------------------------------------------------------------------------------------------------------------------------------------------------------------------------------------------------------------------------------------------|

ALL UNITS IN mm UNLESS NOTED OTHERWISE.



1278 FM 407 Suite 109A25 Lewisville, TX 75055 USA
Tel: 918-299-9290 Fax: 866-910-5912

MSR HSD22

COSTCO GLOUCESTER GAS BAR
GLOUCESTER, ON

DESIGN FLOWRATE: 39.6 USGPM

JOB No.: 11500-001

DATE: 28/04/2025

DRAWN: SJ

APPROV.:

SCALE: 1:45

SHEET:

1



Mohr Separations Research, Inc.

Coalescing Plate Analysis
Rev 2: August 2010

Customer: Echelon Costco Ottawa
Customer Ref:

MSR Ref: Q25 3784 rev 1
Date: 28-Apr-25

Continuous Fluid

Fluid: Water
Flow Rate: US gpm = 105
Temperature, Deg. F.= 32
Viscosity Used, Cp = 1.792
Specific Gravity Used = 1.001

Flow Rate, m3 / hour = 23.85
Temperature, Deg. C = 0.0

Immiscible Phase

Material: Oil
Specific Gravity: 0.85
Measured at Deg. F. 60
Specific Gravity at Temp.= 0.862

Log Normal Distribution
Concentration, mg/l 100
Mean size, microns 120
Standard Deviation 2

Plate Pack Configuration

Packs Wide =	2	Number of Rows	1
Total Width, inches =	23.6	Flow Path, Inches =	23.6
Total Width, mm =	600	Flow Path, mm	600
Height, inches =	31.5	Plates / Stack foot =	30
Height, mm =	800		

Plates / Fluid Characteristics

Flow Rate, gpm 105.0
Stack Feet provided 5.25
gpm / stack foot 20.00
Frontal Area, ft² 5.167
Plate Volume, ft³ 10.172
gpm/ft² frontal area 20.320
Velocity in plates, ft/min 3.394
Res. time in plates, min 0.589
Plates / stack foot 30.0
Plate spacing nominal 8 mm NOM.
Plate Surface area, ft² 915
Pressure drop, in H₂O 0.06
Reynolds No. in plates 101.4
Percent of Laminar Limit 5.1

Effluent Characteristics

Oil
Effluent mg/l 11.3
Percent Reduction 88.7
Size 100% collected, microns 73.2
Collection rate, lbs / hour 4.66
Gallons / hour 0.65
Collection rate, kg/hour 2.12
l / hour 2.45