



Site Servicing and Stormwater Management Report 1015 Tweddle Road, Ottawa, ON

Client:

Trim 1 GP Inc.
7 de Tellier
Gatineau, QC J8T 8C2

Submitted for:

Site Plan Application (SPA)

Project Name:

1015 Tweddle Road

Project Number:

OTT-00259629-A0

Prepared By:

EXP
2650 Queensview Drive
Ottawa, ON K2B 8H8
t: +1.613.688.1899
f: +1.613.225.7337

Date Submitted:

May 30, 2025
Rev 1 September 25, 2025
Rev 2 November 18, 2025
Rev 3 March 13, 2026

Site Servicing and Stormwater Management Report 1015 Tweddle Road, Ottawa, ON

Client:

Trim 1 GP Inc.
7 de Tellier
Gatineau, QC J8T 8C2

Submitted for:

Site Plan Application (SPA)

Project Name:

1015 Tweddle Road

Project Number:

OTT-00259629-A0

Prepared By:

EXP
2650 Queensview Drive
Ottawa, ON K2B 8H8
t: +1.613.688.1899
f: +1.613.225.7337

Prepared by:

Approved by:

Jason Fitzpatrick, P.Eng.
Project Engineer

Bruce Thomas, P.Eng.
Senior Project Manager

Date Submitted:

May 30, 2025
Rev 1 September 25, 2025
Rev 2 November 18, 2025
Rev 3 March 13, 2026

Table of Contents

1	Introduction	1
1.1	Overview	1
2	Existing Conditions.....	2
2.1	Site Topography.....	2
3	Existing Infrastructure.....	3
4	Pre-Consultation / Permits / Approvals.....	4
5	Water Servicing.....	5
5.1	Water Servicing Design Criteria	5
5.2	Water Servicing Proposal.....	5
5.3	Estimated Water Demands.....	6
5.4	Boundary Conditions	6
5.5	Fire Flow Requirements.....	7
5.6	Review of Hydrant Spacing	7
5.7	Water Servicing Design	8
6	Sanitary Sewage Servicing	10
6.1	Sanitary Sewage Design Criteria	10
6.2	Proposed Sewage Conditions	10
6.3	Offsite Sanitary Sewer Review	11
7	Storm Servicing & Stormwater Management.....	13
7.1	Design Criteria.....	13
7.1.1	Minor System Design Criteria	13
7.1.2	Major System Design Criteria	13
7.2	Runoff Coefficients	13
7.3	Pre-Development Release Rate	14
7.4	Post-Development Stormwater Management Scheme.....	14
7.5	Stormwater Model Development.....	14
7.6	Rainfall Data.....	15
7.7	Proposed Stormwater System	16
7.8	Stormwater Model Results	17
7.9	Quality Control.....	17
7.10	Jeanne-d’Arc Blvd Drainage Catchment	17

7.11 Tweddle Road Drainage Catchment	20
8 Erosion & Sediment Control	22
9 Conclusions and Recommendations.....	23

List of Figures

Figure 1-1 - Site Location	1
Figure 2-1 - Site Topography.....	2
Figure 5-1 – Review of Hydrant Spacing	9
Figure 7-1: Hydraulic Grade Lines of 2-yr and 100-yr Storms of Jeanne-d’Arc Storm Sewers	19
Figure 7-2: Flows and Water Depths at 500mm Culvert	21
Figure A1 – Post-Development Subcatchments	A
Figure A2 – JDA Subcatchments	A
Figure A3 – Tweddle Subcatchments.....	A

List of Tables

Table 5-1 - Summary of Water Supply Design Criteria	5
Table 5-2 : Water Demand Summary	6
Table 5-3 - Summary of Design Parameters Used in Calculating Required Fire Flows (RFF) Using FUS.....	7
Table 5-4 –Fire Flows Based on Hydrant Spacing	8
Table 6-1 – Summary of Wastewater Design Criteria / Parameters.....	10
Table 6-2 – Summary of Anticipated Sewage Rates	11
Table 7-1 – Summary of Stormwater Peak Flows.....	14
Table 7-2 : Subcatchment Parameters	14
Table 7-3 : Summary of Rainfall Data (From City of Ottawa SDG002).....	16
Table 7-4 : Summary of Post-Development Flows at Outfall #1.....	17
Table 7-5 – Design Parameters Used for Oil Grit Separator Sizing.....	17
Table 7-6 : Discharge Rates for Standard IPEX Tempests Type A	18
Table 7-7 : Summary of Post-Development Flows at Outfall #2.....	19
Table 7-8 : Summary of Post-Development Flows at Outfalls #1A, 3, and 4.....	20
Table B1 – Water Demand Chart	B
Table B2 – Summary of Required Fire Flows (RFFs)	B
Table B3 – Fire Flow Requirements Based on Fire Underwriters Survey (FUS) – Tower B1.....	B
Table B4 – Fire Flow Requirements Based on Fire Underwriters Survey (FUS) – Tower B2.....	B
Table B5 – Fire Flow Requirements Based on Fire Underwriters Survey (FUS) – Tower B3.....	B
Table B6 – Fire Flow Requirements Based on Fire Underwriters Survey (FUS) – Tower B4.....	B
Table B7 – Fire Flow Requirements Based on Hydrant Spacing	B

Table B8 – Sanitary Sewer Design Sheet..... B
Table B9 – Storm Sewer Design Sheet B
Table B10 – Calculation of Average Runoff Coefficients for Pre-Development Conditions B
Table B11 – Calculation of Catchment Time of Concentration for Pre-Development Conditions B
Table B12 – Calculation of Peak Runoff for Pre-Development Conditions..... B

List of Appendices

Appendix A – Figures A
Appendix B – Design Tables B
Appendix C – Manufacturers Information C
Appendix D – Consultation / Correspondence D
Appendix E – Drawings E
Appendix F – PCSWMM Results..... F

1 Introduction

1.1 Overview

EXP Services Inc. (EXP) was retained by Trim 1 GP Inc. to prepare a Site Servicing and Stormwater Management Report for the proposed development of 1015 Tweddle Road in support of the Site Plan Application.

The site is situated at the north-east corner of Tweddle Road and Jeanne D'Arc Boulevard North as illustrated in **Figure 1-1** below. The site is within the City of Ottawa urban boundary and situated in Orleans Ward (Ward 1).



Figure 1-1 - Site Location

The overall property area is 3.42 ha. The proposed development will occupy 1.28 ha of the total property parcel. The proposed development will consist of four high-rise buildings. Tower B1 and B3 both will be 28 storey, tower B2 will be 32 storey and tower B4 will be 24 storeys high. All four towers will be constructed above underground parking. Proposed development will have total 1,258 residential units and around 2,471 m² of commercial/retail space. Tower B1 will have 326 units, Tower B2 will have 372 units, Tower B3 will have 324 units and Tower B4 will have 2236 units.

This report will discuss the adequacy of the adjacent municipal watermain, sanitary sewers and storm sewers to provide the required water supply, convey the sewage and stormwater flows that will result from the proposed development.

2 Existing Conditions

2.1 Site Topography

The site is currently undeveloped. The site is bounded to the west by Tweddle Road, to the south by Jeanne-D'Arc Boulevard North to the east by undeveloped land, and to the north by the Ottawa River. **Figure 2-1** below illustrates the topography of the site which slopes in a northerly direction towards the Ottawa River.

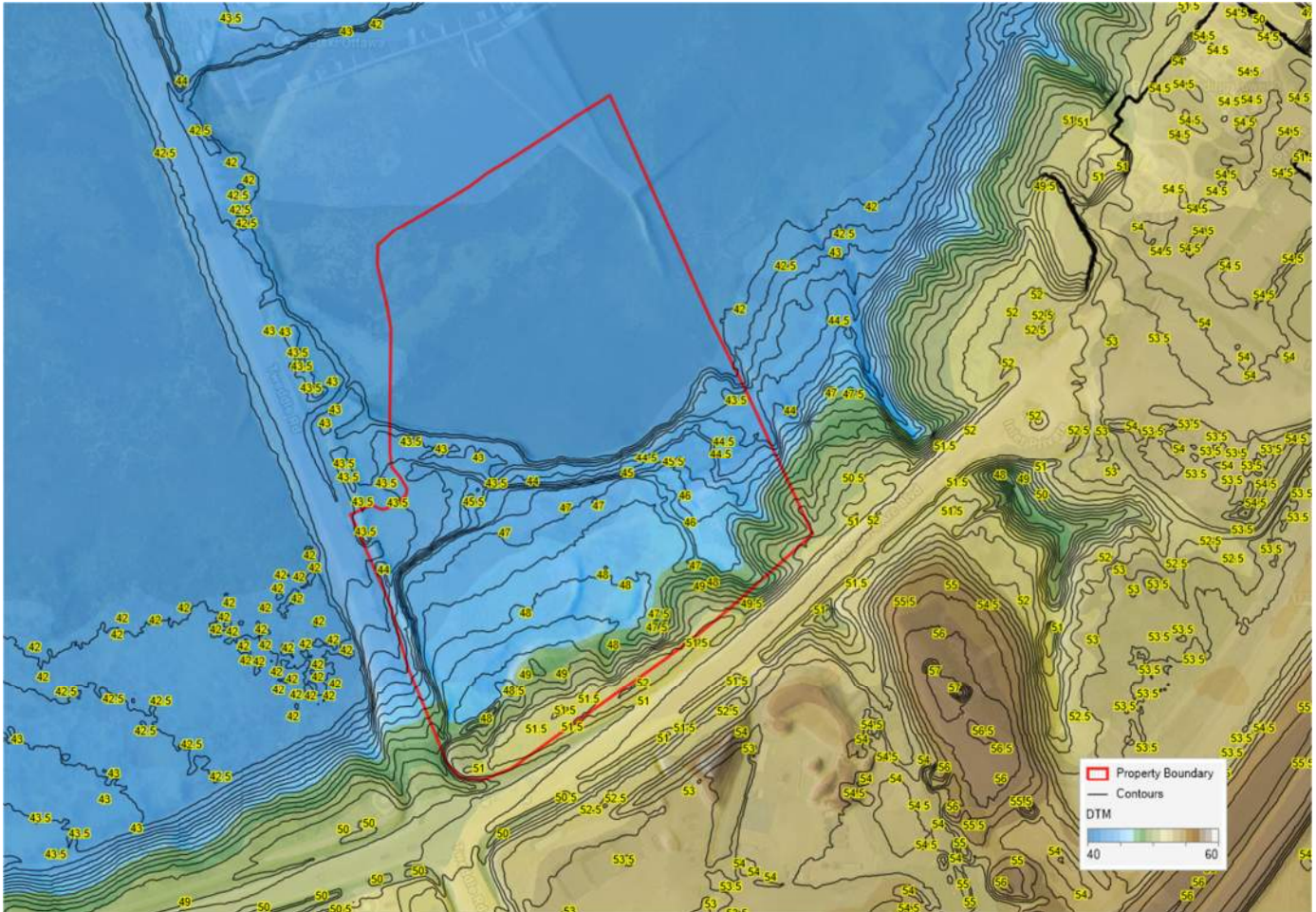

Figure 2-1 - Site Topography

Within the site the topography ranges from $\pm 52\text{m}$ down to $\pm 42\text{m}$. A digital terrain model (DTM) was derived from 2019-2020 Ottawa Gatienau LIDAR Derived DTM (Land Inventory Ontario) and is shown in **Figure 2-1**. The normal water surface elevation within the adjacent Ottawa River is approximately $\pm 42.0\text{m}$, with a 100-year flood elevation being 45.0m . The Topographic Survey in **Appendix E** shows Ottawa River Normal High Water Mark, Edge of Wetlands, Ottawa River 100-Yr Regulatory Floodplain, Limit of Hazard Lands, Top of Slope Line, 15m Setback from Top of Slope and 30m Setback from Wetlands.

3 Existing Infrastructure

From review of the sewer and watermain mapping, as-built drawings and the City's GeoOttawa mapping, the following summarizes the onsite and adjacent offsite infrastructure:

Within property

- Subject property is currently undeveloped with no services or utilities

Within Jeanne-D'Arc Boulevard North, opposite the site

- 406 mm watermain and fire hydrants
- 300mm sanitary sewer
- Open drainage ditches on east side of Trim Road and along the north side of Jeanne D'Arc Boulevard North
- Enbridge Consumers Gas
- Overhead hydro lines and communication cables

Within Tweddle Road

- 75 mm watermain
- 75mm sewage forcemain
- Overhead Hydro and communication

4 Pre-Consultation / Permits / Approvals

A pre-consultation meeting was held with the City prior to design commencement. This meeting, held August 1, 2024, outlined the submission requirements and provided information to assist with the development proposal.

The proposed site is located within the Rideau Valley Conservation Authority (RVCA) jurisdiction, therefore signoff from the RVCA will be required. From previous development consultation on the property, the RVCA has noted that enhanced protection (80% TSS removal) is required. The RVCA has been contacted to confirm the stormwater management quality control requirements.

Stormwater management quantity control will not be required for the portion of the development that will be discharging directly to the Ottawa River. Additional information on this will be provided in proceeding sections.

An Environmental Compliance Approval (ECA) will be required from the Ministry of Environment, Conservation and Parks (MECP), for the upsizing of the sanitary sewer and the proposed storm sewer within Jeanne D'Arc Boulevard. A MECP ECA will also be required for the stormwater discharge from the site to the Ottawa River. Design Guidelines

Various design guidelines were referred to in preparing the current report including:

- Bulletin ISDTB-2012-4 (20 June 2012)
 - Technical Bulletin ISDTB-2012-04
 - Technical Bulletin ISDTB-2014-01
 - Technical Bulletin PIEDTB-2016-01
 - Technical Bulletin ISDTB-2018-01
 - Technical Bulletin ISDTB-2018-03
 - Technical Bulletin ISDTB-2018-04
 - Technical Bulletin ISDTB-2019-02
 -
- Ottawa Design Guidelines – Water Distribution, July 2010 (WDG001), including:
 - Technical Bulletin ISDTB-2010-02
 - Technical Bulletin ISDTB-2014-02
 - Technical Bulletin ISTB-2018-02
 - Technical Bulletin ISTB-2021-03
- Stormwater Management Planning and Design Manual, Ontario Ministry of the Environment and Climate Change, March 2003 (SMPDM).
- Design Guidelines for Drinking-Water Systems, Ontario Ministry of the Environment and Climate Change, 2008 (GDWS).
- Fire Underwriters Survey, Water Supply for Public Fire Protection (FUS), 2020.
- Ontario Building Code 2012, Ministry of Municipal Affairs and Housing.

5 Water Servicing

5.1 Water Servicing Design Criteria

Table 5-1 below summarizes the Design Criteria that was used to establish the water demands and the required fire flows, based on the proposed building uses. The design parameters that apply to this project and used for calculations are identified below.

Table 5-1 - Summary of Water Supply Design Criteria

Design Parameter	Value	Applies
Population Density – Single-family Home	3.4 persons/unit	
Population Density – Semi-detached Home	2.7 persons/unit	
Population Density – Townhome or Terrace Flat	1.8 persons/unit	
Population Density – Bachelor Apartment	1.4 persons/unit	
Population Density – Bachelor + Den Apartment	1.4 persons/unit	
Population Density – One Bedroom Apartment	1.4 persons/unit	✓
Population Density – One Bedroom plus Den Apartment	1.4 persons/unit	✓
Population Density – Two Bedroom Apartment	2.1 persons/unit	✓
Population Density – Two Bedroom plus Den Apartment	2.1 persons/unit	
Population Density – Three Bedroom Apartment	3.1 persons/unit	✓
Average Day Demands – Residential	280 L/person/day	✓
Average Day Demands – Commercial / Institutional	5 L/m ² floor area/day	✓
Average Day Demands – Light Industrial / Heavy Industrial	35,000 or 55,000 L/gross ha/day	
Maximum Day Demands – Residential	2.5 x Average Day Demands	✓
Maximum Day Demands – Commercial / Institutional	1.5 x Average Day Demands	✓
Peak Hour Demands – Residential	5.5 x Average Day Demands	✓
Peak Hour Demands – Commercial / Institutional	2.7 x Average Day Demands	✓
Fire Flow Requirements Calculation	FUS	✓
Depth of Cover Required	2.4m	✓
Maximum Allowable Pressure	551.6 kPa (80 psi)	✓
Minimum Allowable Pressure	275.8 kPa (40 psi)	✓
Minimum Allowable Pressure during fire flow conditions	137.9 kPa (20 psi)	✓

5.2 Water Servicing Proposal

The proposed development will include 1,257 residential units and 4,200 square meters of level 1 and level 2 retail space housed within the four towers.

Architectural plans and rendering of the proposed building along with building statistics are provided in **Appendix E**.

It is proposed that the water supply for the site will be provided by two twin 200mm watermains supplied from the existing 406mm watermain on Jeanne D’Arc Boulevard North. The development will require independent and twin watermain services, which is the result of the average day water demands exceeding 50 m³/day. The watermain feeds from the underground parking level will connect directly to the existing 406mm watermain on Jeanne D’Arc Boulevard and will have an isolation valve between them, consistent with City of Ottawa Water Design Guidelines.

The buildings will be protected by an automatic sprinkler system. Fire department connections (or siamese) will be located within 45 metres of existing adjacent municipally owned fire hydrants for towers B2, B3 and B4. In existing conditions there are no fire hydrants within Tweddle Road in near proximity of Tower B1. A new fire hydrant and lead are required on Tweddle Road to service Tower B1. Hence, it is proposed to extend a municipal 200mm diameter watermain within Tweddle Road to be capped north of the new fire hydrant.

5.3 Estimated Water Demands

The following **Table 5-2** below summarizes the anticipated water demands for the proposed development based on following:

- 4 towers having total 1,257 residential units. Estimated residential population of 2,002 persons.
- Commercial & Amenity spaces on level 1 and 2. Estimated area of 4,027 m².

Table 5-2 : Water Demand Summary

Water Demand Conditions	Tower B1 Water Demands (L/sec)	Tower B2 Water Demands (L/sec)	Tower B3 Water Demands (L/sec)	Tower B4 Water Demands (L/sec)	Total Water Demands (L/sec)
Average Day	1.79	2.01	1.75	1.07	6.62
Max Day	4.42	4.99	4.33	2.68	16.42
Peak Hour	9.65	10.92	9.46	5.89	35.92

5.4 Boundary Conditions

Hydraulic Grade Line (HGL) boundary conditions were obtained from the City for design purposes. A copy of the correspondence received from the City is provided in **Appendix D**.

The following hydraulic grade line (HGL) boundary conditions were provided:

- Maximum HGL (Average Day) = 113.6 m
- Peak Hour HGL = 106.7 m
- Max Day Plus Fire Flow 1 = 112.0 m (100 L/sec)
- Max Day Plus Fire Flow 2 = 102.9 m (167 L/sec)

The provided HGL ranges of 106.7 m – 113.6 m were used to estimate pressures at the building. Under Max Day Plus fire flow conditions, the lower HGL of 102.9 m was used, whereas for Peak Hour conditions the HGL of 106.7 m was used. Based on a ground elevation of approximately 51.9 m at the boundary condition location this results in a system water pressure of 54.8 m or 78.0 psi during peak hour conditions, and 61.7 m or 87.8 psi at a maximum value (Average Day demand). Therefore, the use of pressure reducing valves should be considered by the mechanical consultant during the design of interior water systems of each new proposed tower.

5.5 Fire Flow Requirements

Water for fire protection will be available utilizing the proposed fire hydrants located along on Jeanne D’Arc Boulevard. The required fire flows for the proposed buildings were calculated based on typical values as established by the Fire Underwriters Survey 2020 (FUS).

The following equation from the Fire Underwriters document “Water Supply for Public Fire Protection”, 2020, was used for calculation of the on-site supply rates required to be supplied by the hydrants:

$$F = 200 * C * \sqrt{A}$$

where:

F	=	Required Fire flow in Litres per minute
C	=	Coefficient related to type of Construction
A	=	Total Floor Area in square metres

The proceeding **Table 5-3** summarizes the parameters used for estimating the Required Fire Flows (RFF) based on the Fire Underwriters Survey (FUS) and the latest City of Ottawa Technical Bulletins. The RFFs were estimated in accordance with ISTB-2018-02, and based on floor areas provided by the architect, which are illustrates in **Appendix E**.

Detailed calculation of Required Fire Flow (RFF) for proposed buildings can be found in **Table B3** to **Table B6** in **Appendix B**.

Table 5-3 - Summary of Design Parameters Used in Calculating Required Fire Flows (RFF) Using FUS

Building #	No of Storeys	Fire Flow, F (L/min)	Type of Constr. Coeff, C	Reduction Due to Occupancy (%)	Reduction Due to Sprinklers (%)	Total Increase due to Exposures (%)	Required Fire Flow in	
							(L/min)	(L/sec)
Tower B1	28	15,000	0.8	-15%	-50%	5%	7,000	117
Tower B2	32	14,000	0.8	-15%	-50%	10%	7,000	117
Tower B3	28	14,000	0.8	-15%	-50%	10%	7,000	117
Tower B4	24	13,000	0.8	-15%	-50%	5%	6,000	100

5.6 Review of Hydrant Spacing

A review of the hydrant spacing was completed to ensure compliance with Appendix I of Technical Bulletin ISTB-2018-02. As per Section 3 of Appendix I all hydrants within 150 metres were reviewed to assess the total possible available flow from these contributing hydrants. For each hydrant the distance to the proposed building was determined to arrive at the contribution of fire flow from each. All hydrants are expected to be of Class AA as per Section 5.1 of Appendix I. For each hydrant the straight-line distance, distance measured along a fire route or roadway, whether its location is accessible, and its contribution to the required fire flow.

Figure 5-1 below illustrates all the hydrants that are within the 75 metre and 150 metre offsets from the subject property. Fire hydrants that are denoted with a number having a HP versus H represents a PRIVATE hydrant rather than a CITY owned hydrant. All hydrants were reviewed to determine if they were accessible or non-accessible. For example, a hydrant would not be accessible if they were located on the opposite side of a median, limiting fire truck access. A summary table of the total fire flows available versus the required fire flows (RFFs) is presented in **Table 5-4** below.

Table 5-4 –Fire Flows Based on Hydrant Spacing

Building	Required Fire Flow (L/min)	Available Fireflow Based on Hydrant Spacing as per ISTB-2018-02 (L/min)
Tower B1	7,000 (or 100 L/sec)	13,300
Tower B2	7,000 (or 117 L/sec)	19,000
Tower B3	7,000 (or 117 L/sec)	13,300
Tower B4	6,000 (or 100 L/sec)	9,500

Detailed calculations of the available fire flows based on hydrant spacing is provided in **Table B7** found in **Appendix B**. Therefore, the available flows from hydrants exceed each building’s fire flow requirements as identified in Appendix I of Technical Bulletin ISTB-2018-02.

5.7 Water Servicing Design

The water servicing requirements for the proposed building is designed in accordance with the City Design Guidelines (July 2010). The following steps indicate the basic methodology that was used in our analysis:

- Estimated water demands under average day, maximum day and peak hour conditions. As the total population estimate is greater than 500, standard residential peaking factors were used.
- Estimated the required fire flow (RFF) based on the Fire Underwriters Survey (FUS).
- Reviewed the available flows from hydrants within 150m of the buildings, based on the City’s WDG002 and compared to the required fire flows (RFFs) based on the Fire Underwriters Survey (FUS).
- Obtained hydraulic boundary conditions (HGL) from the City, based on the above water demands and required fire flows.
- Boundary condition data and water demands were used to estimate the pressure at the proposed building, and this was compared to the City’s design criteria.

Since the average day demand exceed 50 m³ per day, two watermain feeds for the development will be necessary as per Section 4.31 of the WDG001. Please refer to **Table B1** in **Appendix B** for detailed calculations of the total water demands.

Figure 5-1 – Review of Hydrant Spacing

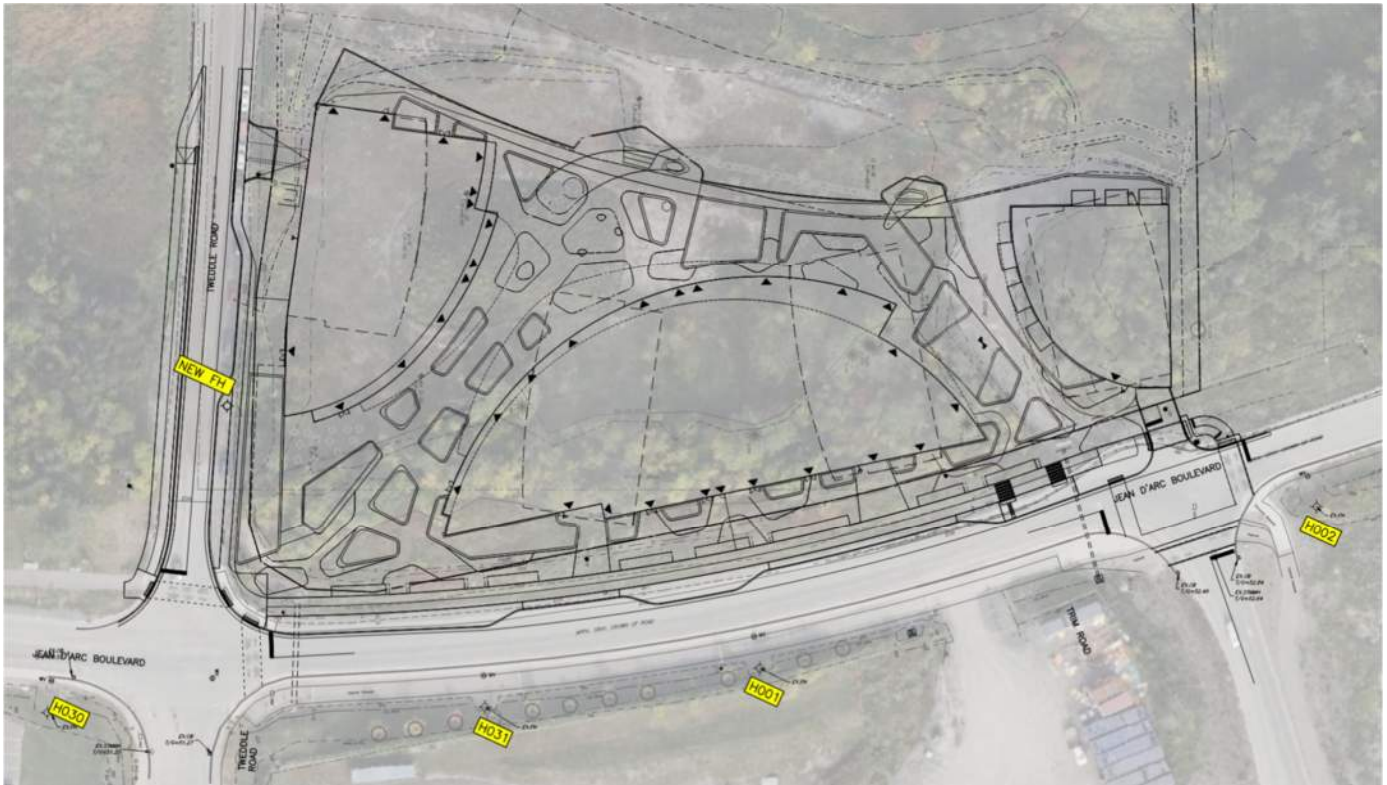

Based on the hydraulic grade line (HGL) provided from the City it is evident that high pressures exist in the water distribution system at the property. Static pressures of ± 70 psi – 90 psi are typically available. This is due to the lower elevation relative to the reservoir.

Based on the results, the installation of three twin 200mm watermains with a shut-off valve between them is proposed. As the maximum hydraulic grade line (HGL) provided by the city indicates pressures greater than 80 psi, pressure reducing measures will be required.

6 Sanitary Sewage Servicing

6.1 Sanitary Sewage Design Criteria

The sanitary sewer system is designed based on a population flow and an area-based infiltration allowance. The flows were calculated using City sewer design guidelines (SDG002). **Table 6-1** below summarizes the design parameters used.

Table 6-1 – Summary of Wastewater Design Criteria / Parameters

Design Parameter	Value	Applies
Population Density – Single-family Home	3.4 persons/unit	
Population Density – Semi-detached Home	2.7 persons/unit	
Population Density – Duplex	2.3 persons/unit	
Population Density – Townhome (row)	2.7 persons/unit	
Population Density – Bachelor Apartment	1.4 persons/unit	
Population Density – Bachelor + Den Apartment	1.4 persons/unit	
Population Density – One Bedroom Apartment	1.4 persons/unit	✓
Population Density – One Bedroom plus Den Apartment	1.4 persons/unit	✓
Population Density – Two Bedroom Apartment	2.1 persons/unit	✓
Population Density – Two Bedroom plus Den Apartment	2.1 persons/unit	✓
Population Density – Three Bedroom Apartment	3.1 persons/unit	✓
Average Daily Residential Sewage Flow	280 L/person/day	✓
Average Daily Commercial / Intuitional Flow	28,000 L/gross ha/day	✓
Average Light / Heavy Industrial Daily Flow	35,000 / 55,000 L/gross ha/day	
Residential Peaking Factor – Harmon Formula (Min = 2.0, Max =4.0, with K=0.8)	$M = 1 + \frac{14}{4 + P^{0.5}} * k$	✓
Commercial Peaking Factor	1.5	✓
Institutional Peaking Factor	1.5	
Industrial Peaking Factor	As per Table 4-B (SDG002)	
Unit of Peak Extraneous Flow (Dry Weather / Wet Weather)	0.05 or 0.28 L/s/gross ha	
Unit of Peak Extraneous Flow (Total I/I)	0.33 L/s/gross ha	✓

6.2 Proposed Sewage Conditions

It is proposed that the mechanical piping from each building discharge into a sanitary manhole onsite, which will then discharge to the existing sanitary sewer on Jeanne-D’Arc Boulevard. This manhole will be installed near the property line and be used as a monitoring manhole.

Three 375mm diameter sanitary service laterals are proposed to service the full development. The estimated peak sanitary flow rate from the proposed property is **20.50/sec** based on City Design Guidelines. Sewage rates include a total infiltration allowance of 0.33 L/ha/sec based on the total gross site area.

Table 6-2 below summarizes the sewage anticipated peak sewage flows for the proposed site.

Table 6-2 – Summary of Anticipated Sewage Rates

Sewage Condition	Sanitary Sewage Flow (L/sec)
Peak Residential Flow (for 2,002 persons)	19.92
Peak Commercial Flow (for 4,027 m ²)	0.20
Infiltration Flow (for 1.16 ha)	0.38
Peak Design Flow	20.50

6.3 Offsite Sanitary Sewer Review

The sanitary sewer run on Jeanne D’Arc Boulevard North (from Tweddle Road easterly to municipal limits) was designed and constructed to allow for the development of Phase I (Tower 1) of Brigil’s Petrie’s Landing II to proceed. Approximately 320 metres of sanitary sewer was extended from the Tweddle Road (Formerly Trim Road) intersection easterly to service Petrie’s Landing II. A review of previous reports by David MacManus (DME) for Phase 1, and EXP Services (EXP) for Phase 2, confirmed that the sanitary sewer system on Jeanne D’Arc Boulevard North was sized, not only for the 3.9-hectare Petrie’s Landing development site, but also for an additional 9.9 hectares of commercial development along Jeanne D’Arc Boulevard North. The commercial flow allowance established was 50,000 L/ha/day and included an additional infiltration allowance at 0.28 L/ha/sec.

As taken from the DME report, the total peak sanitary flows from both Petrie’s Landing development (all 5 phases) and the additional 9.9 hectares was 34.7 L/sec, which included ±23.4 L/sec from Petrie’s Landing and ±11.4 L/sec from the additional area along Jeanne D’Arc Boulevard North. At the time of the design of Tower 1 by DME, this was based on a residential population of 1512 persons.

In 2016, during the design of Tower 2 by EXP Services Inc (EXP), further refinement of the sanitary sewage flows from the Petrie’s II Landing development was completed, based on number of proposed residential units. A revised population of 1822 persons was used and included the same offsite commercial flow allowance for the 9.9-hectares along Jeanne D’Arc Boulevard North. The peak flow was updated to 39.2 L/sec with 27.8 L/sec from Petrie’s Landing development and 11.4 L/sec from the offsite areas.

The review of all sanitary sewer runs on Jean D’Arc Boulevard North were completed based on the most up to date information. A sanitary sewer design sheet was compiled based on data from the Petrie’s Landing II project and based on the City’s most recent Technical Bulletins. It should be noted that March 2018, revisions to the City’s SDG002, were made to residential flow allowances as noted in Technical Bulletin ISTB-2018-01. The per capita flow allowance was lowered from 350 L/p/day to 280 L/p/day, along with the addition of the correction factors of 0.8 to the Harmon Formula Peaking Factors. These revised allowances were used to review sanitary sewer capacities.

Table B8 in **Appendix B** summarizes the anticipated peak sewage flows in all sanitary sewers runs up to the Tweddle Road (formerly Trim Road) intersection, whereas *Sanitary Drainage Area Plan C500* illustrates the sanitary drainage areas tributary to this sewer run.

It should be noted that the developer has proposed to acquire Part 9 of Plan 50R-5818 – Jeanne D’Arc ROW at the north-east corner of Jeanne D’Arc Boulevard North and Tweddle Road (formerly Trim Road), from the City. Sanitary manhole #MHSA22037 is proposed to be relocated outside the property line and sanitary manhole MH#54993 is proposed to be relocated further east. With this relocation, the structures can be used for monitoring sanitary discharge from the development as sanitary laterals are proposed to connect to the relocated structures. It is also

proposed to upsize the pipes between MHSA22037 & MHSA54992 from 300mm dia. to 375mm dia. as shown on *Site Servicing Plan C100*.

Table B8 in **Appendix B** shows that the most restricted proposed 375 sanitary sewer will run at 57% capacity at 0.16% slope, with full flow capacity of ± 77.13 L/sec.

For the site at 1015 Tweddle Road (formerly 1009 Trim Road), three 375mm diameter PVC sewer laterals having a minimum slope of 2.0% are proposed to service the development. The estimated capacity of a 375mm pipe at 2% is ± 272 L/sec. A lateral at this slope would permit 8,300 fixture units as per OBC. Further detail and coordination with mechanical consultant will be advanced as the project progresses.

7 Storm Servicing & Stormwater Management

7.1 Design Criteria

The subject property is located within the Rideau Valley subwatershed; therefore, stormwater works are subject to both the Rideau Valley Conservation Authority (RVCA) and City of Ottawa (COO) approval.

The RVCA has noted that (80% TSS removal) quality control requirements for the site will be required.

Also clarified during the pre-consultation meeting, the requirements related to stormwater quantity control are noted as follows:

- *No quantity control is required for this development ONLY if it is discharging to the river.*
- *Please contact the City if this development will require municipal stormwater servicing.*

The proposed stormwater system is designed in conformance with the latest version of the City of Ottawa Design Guidelines (October 2012). Section 5 “Storm and Combined Sewer Design” and Section 8 “Stormwater Management”. A summary of the design criteria that relates to this design report is the proceeding sections below.

7.1.1 Minor System Design Criteria

- The storm sewer sizing will be based on the Rational Method and Manning’s Equation under free flow conditions for the 2-year storm using a 10-minute inlet time.
- Minimum sewer slopes to be based on minimum velocities for storm sewers of 0.80 m/sec.

7.1.2 Major System Design Criteria

- Any onsite stormwater detention (if used) will be estimated based on the 100-year design storm. It is proposed that roof top storage be incorporated where possible.
- Onsite detention will be estimated using the Modified Rational Method (MRM).
- Emergency overland flow routes are provided.
- The vertical distance from the spill elevation on the street and the ground elevation at the buildings is at least 150mm.
- The emergency overflow spill elevation is at least 30 cm below the lowest building opening.

7.2 Runoff Coefficients

Runoff coefficients used were based on actual areas taken from CAD. Runoff coefficients for impervious surfaces (roofs, asphalt, and concrete) were taken as 0.90, whereas those for pervious surfaces (grass/landscaping) were taken as 0.20. Runoff coefficient for gravel surface was taken as 0.75. Average runoff coefficients were calculated for catchments (or drainage areas) using the area-weighting method in Excel or spatial-weighting in PCSWMM. The runoff coefficients for the pre-development are provided in **Table B10**.

7.3 Pre-Development Release Rate

The proposed development will occupy 1.28 ha out of 3.42 ha of total site area. Pre-development runoff coefficient for 1.28 ha site area was estimated to be 0.29. The calculated time of concentration was 3.58 mins. Therefore, the pre-development discharge rates during 2-year, 5-year and 100-year storm events were estimated with average runoff coefficient of 0.29 and time of concentration of 10 mins as per the City of Ottawa guidelines, summarized in Table 7-1 below. Detailed calculation of pre-development peak runoff rate can be found in **Table B12** in **Appendix B**.

Table 7-1 – Summary of Stormwater Peak Flows

Development	Pre-Development Discharge Rates (L/sec)		
	2-year	5-year	100-year
1015 Tweddle Road (formerly 1009 Trim Road)	79.1	107.3	229.9

7.4 Post-Development Stormwater Management Scheme

As noted above, the City of Ottawa permitted no quantity control of post-development runoff due to the sites proximity to the Ottawa River, if stormwater system is discharging directly into the Ottawa river. The portion of development discharging to the City ROW would be controlled to 5-year pre-development discharge rates with maximum runoff coefficient of 0.5. However, at this stage, the whole site is proposed to discharge via one outlet to the north into the Ottawa River. Therefore, no quantity control has been proposed.

7.5 Stormwater Model Development

PCSWMM was used to create a hydrologic/hydraulic model of the stormwater system. The model includes both the minor system (storm sewer), for estimating peak flows and runoff volumes and the major system (roads and swales, etc.). Calculations of runoff was completed based on the PCSWMM’s EPA SWM 5 engine.

PCSWMM is an advanced software application for stormwater, wastewater, watershed, and water distribution system modelling. PCSWMM was developed by Computational Hydraulics International (CHI) <https://www.chiwater.com/Home> and is based on the EPA storm water management model (SWMM), which is a dynamic rainfall-runoff-routing simulation model used for single event or long-term (continuous) simulation of runoff. PCSWMM was used to determine peak runoff rates and provide hydraulic profiles of the depth of runoff during various storm events. PCSWMM calculates runoff based on the non-linear reservoir model for subcatchments. The model conceptualizes a subcatchment as a rectangular surface that has a uniform slope and a width that drains to a single outlet. The subcatchments receive inflow from precipitation and losses from evaporation and infiltration. The net excess volume ponds atop the subcatchment surface. Pondered water above the depression storage depth, can become runoff outflow. Depression storage accounts for initial rainfall abstractions such as surface ponding, interception by flat roofs and vegetation and surface wetting.

Subcatchment parameters were taken from City of Ottawa’s SDG002 Design parameters. The following design parameters and assumptions are noted in

Table 7-2 below:

Table 7-2 : Subcatchment Parameters

Parameter	PCSWMM Parameter	Value
Infiltration Loss Method		Horton
Maximum Infiltration Rate	Max. Infil. Rate	76 mm/hr
Minimum Infiltration Rate	Min. Infil. Rate	13.2 mm/hr
Decay Constant (1/hr)	Decay Constant	4.14
Manning N (Impervious)	N Impev	0.013
Manning N (Pervious)	N Perv	0.25
Depression Storage – Impervious Surfaces	Dstore Imperv	1.57 mm
Depression Storage – Pervious Surfaces	Dstore Perv	4.67 mm
Zero Percent Impervious	Zero Imper	varies
Subcatchment Slopes	Slope	varies

The following design parameters and assumptions are noted as follows:

- Subcatchment areas were derived tributary to each surface inlet (catchbasin).
- Runoff coefficient for all subcatchments were determined using area weighting routine and based on actual hard and soft surface areas. Runoff coefficients were calculated from the impervious levels using the relationship $C = (IMP \times 0.7) + 0.20$.
- Subcatchment widths are determined using PCSWMM. A Flow-Path layer was created in PCSWMM, and flow paths were created for each subcatchment. The software averages the flow path lengths to calculate the subcatchment widths. The width is equal to the subcatchment area divided by the overland flow path length.
- 2-year, 3-hour Chicago storm used to review minor system design based on Rational Method.
- 3-hr, 2-year, 5-year, 100-year, and 100-year +20% storms were used to assess the impact of major event and determine peak flows and depth of runoff.

7.6 Rainfall Data

Rainfall used for stormwater modelling and calculations were based on data provided in the City of Ottawa’s Sewer Design Guidelines (SDG002). Generation of storm hyetographs for use in hydraulic/hydraulic modelling were derived from the total rainfall depths for various storm durations noted in the **Table 7-3** below. Chicago storm distributions were established using PCSWMM’s Design Storm Creator using a,b,c IDF parameters taken from Section 5.4.2 of the SDG002.

Table 7-3 : Summary of Rainfall Data (From City of Ottawa SDG002)

Duration	Rainfall Amounts (mm) for Specified Return Period					
	2-year	5-year	10-year	25-year	50-year	100-year
5 mins	9.8	13.1	15.2	17.9	19.9	21.8
10 mins	12.1	16.2	18.7	22.1	24.5	26.9
15 mins	13.7	18.3	21.2	24.9	27.7	30.4
30 mins	16.9	22.5	26.1	30.7	34.1	37.4
1 hour	20.8	27.7	32.1	37.8	42.0	46.1
2 hours	25.6	34.2	39.6	46.6	51.8	56.8
6 hours	35.4	47.4	55.2	64.8	72.0	79.2
12 hours	44.4	58.8	68.4	80.4	85.2	97.2
24 hours	55.2	72.0	84.0	98.4	110.4	120.0

Four (4) storm events were modeled including:

- 3-hour 2-year Chicago storm. (10 min timestep), with total rainfall of 31.88mm.
- 3-hour 5-year Chicago storm. (10 min timestep), with total rainfall of 42.54mm.
- 3-hour 100-year Chicago storm. (10 min timestep), with total rainfall of 71.58mm.
- 3-hour 100-year + 20% Chicago storm. (10 min timestep), with total rainfall of 85.9mm.

7.7 Proposed Stormwater System

Stormwater runoff from the proposed site will drain from a combination of controlled and uncontrolled areas. A storm drainage plan is illustrated on Figure A1. A total of eleven (11) subcatchments (or drainage areas) are shown on this drawing with average runoff coefficients calculated for each drainage area. The stormwater works shall consist of the following elements:

- Runoff from Towers B1, B2, B3 and B4 will be collected by roof drains.
- Runoff from surface areas surrounding the proposed towers (S104) will be collected by area drains and discharge to internal drainage piping in the underground parking structure. This in turn discharges directly to an oil-grit separator manhole, prior to discharging to the Ottawa River.
- Runoff from the lower landscaped areas (S015 & S106) along the river front to the north will discharge into the Ottawa River by overland flow.
- Runoff from the lower landscaped areas (S100 & S101) along the Jeanne D' Arc Blvd will be collected by the proposed storm sewer system and discharge into the Ottawa River at new Outfall #2. Detailed discussions of modeled peak runoffs from S100 & S101 are included in **Section 7.11**.
- Runoff from the lower landscaped areas (S102 & S103) along east side of Tweddle Rd will be collected and conveyed by the street gutter on Tweddle Rd and eventually discharge to Ottawa River. Detailed discussions of modeled peak runoffs from S102 & S103 are included in **Section 7.12**.

Drawing C401 shows the existing storm drainage area for the 3 existing culverts along Jeanne D'Arc Boulevard near the proposed site. The existing culvert at the intersection on Jeanne D'Arc Boulevard and Tweddle Road is proposed to be rerouted as shown on servicing plan drawing to allow for the proposed development and to maintain the existing storm drainage pattern.

7.8 Stormwater Model Results

Table 7-4 summarizes the modeled peak flows at Outfall #1, resulting from controlled roof drains (Tower B1, B2, B3, & B4), uncontrolled runoff from low raise roofs and landscaping area (S104), and overland flows from the landscaped area along river front (S105 & S106).

Table 7-4 : Summary of Post-Development Flows at Outfall #1

Storm Event	Peak Flow (L/sec) at Outfall #1
Chicago_3h_2yr	222.4
Chicago_3h_5yr	320.4
Chicago_3h_100yr	572.7
Chicago_3h_100yr + 20%	687.9

7.9 Quality Control

As a total suspended solids (TSS) removal efficiency of 80% is required, it is proposed to provide an oil grit separator for quality control. The following summarizes the design parameters used in the sizing of the Stormceptor manhole.

Table 7-5 – Design Parameters Used for Oil Grit Separator Sizing

Parameter	Value Used
Drainage Area	1.05 hectares
Runoff Coefficient	0.85
Target TSS Removal Requirements	80 %
Target Runoff Volume Capture	90 %
Flow attenuation upstream of OG separator (taken as 100-yr discharge & storage upstream of OG)	none
Particle distribution	fine

Output from the PCSWMM for Stormceptor program is provided in **Appendix E** for reference. A Stormceptor model **EF05** is necessary to meet the required TSS removal of 80%. The EF05 will provide an approximate TSS removal of 83%.

7.10 Jeanne-d’Arc Blvd Drainage Catchment

Urbanization is planned along Jeanne D’Arc Boulevard, as indicated on drawing #EJV-S00174-RWY-DWG-3915 received from the City. As a result of urbanization and proposed development at 1015 Tweddle Road, a storm sewer is proposed under Jeanne D’Arc Boulevard. To allow for the development, the existing culvert and associated upstream drainage area will need to be rerouted to discharge into the proposed storm sewer.

The proposed storm sewer system for Jeanne D’Arc Blvd includes 244 m of storm sewers, with diameter ranging from 300mm to 525 mm. the system also consists of three manholes, three catchbasins, and one outfall structure (Outfall

#2). Additionally, the existing 375mm diameter CSP culvert crossing Jeanne-d’Arc Blvd west of Trim Rd will be connected to the proposed storm sewer.

The contributing drainage subcatchments to the Jeanne D’Arc storm sewer system are illustrated in **Figure A2** of **Appendix A**. Six (6) subcatchments have been identified and analyzed with average runoff coefficients calculated for each drainage area.

- Runoff from Jeanne-d’Arc Blvd Right-Of-Way (S200, S201, &S202).
- Runoff from the development site (S100 & S101).
- Runoff from the existing drainage subcatchments south of Jeanne-d’Arc Blvd (S202 & S203).

Inlet control devices (ICD) will be installed in the proposed catch basins of the Jeanne-d’Arc storm sewer system to manage flows and prevent ponding during the 2-year storm event. There are six (6) primary inlet control devices used in the City of Ottawa for the control of runoff at catchbasins. The standard ICD discharge rates at 1.2 m hydraulic head are 13.4 L/sec, 19.8 L/sec, 28.1 L/sec 36.7 L/sec, 53.2 L/sec and 70.8 L/sec for Pedro Plastics Type X, and IPEX Tempests Type A, B, C, D, and F respectively. Type A was selected for use at most locations based on its suitability for the estimate runoffs and to avoid surface ponding at the ROW and development areas.

Table 7-6 below summarizes the discharge rates of IPEX Tempests Type A inlet control devices used. Please refer to the Storm Drainage Plan and Site Servicing Plans for the ICD types at each catchbasin.

Table 7-6 : Discharge Rates for Standard IPEX Tempests Type A

Head (m)	Discharge (L/s)
0.00	0.0
0.10	5.7
0.20	8.1
0.30	9.9
0.40	11.5
0.50	12.8
0.60	14.0
0.70	15.1
0.80	16.2
0.90	17.2
1.00	18.1
1.20	19.8
1.40	21.4
1.60	22.9
1.80	24.3
2.00	25.6
2.50	28.6
3.00	31.4

The storm sewer system has been designed to convey the runoff up to the 2-year storm event. For larger storm events (e.g. 100-year), excess runoff is managed by the major system. This includes overland flow routes such as swales and streets, which will convey flows toward Tweddle Road and ultimately discharge into the Ottawa River.

The major system was modeled using irregular conduits based on a half-street cross-section. The transect editor in PCSWMM was used to establish this transect, which was applied to the majority of the major system.

Table 7-7 summarizes the modeled peak flows at Outfall #2. These flows include:

- Controlled runoff from Jeanne-d’Arc ROW (S200, S201, & S204),
- Uncontrolled runoffs from existing subcatchments south of Jeanne-d’Arc Blvd (S202 & S203), and
- Overland flows from the development site (S100 & S101).

Table 7-7 : Summary of Post-Development Flows at Outfall #2

Storm Event	Peak Flow (L/sec) at Outfall #2
Chicago_3h_2yr	206.0
Chicago_3h_5yr	282.9
Chicago_3h_100yr	332.6
Chicago_3h_100yr + 20%	354.7

Figure 7-1 below illustrates a profile of the Jeanne-d’Arc storm sewer from its starting point to Outfall #2. Plotted on this figure is the 2-yr and 100-yr HGL.

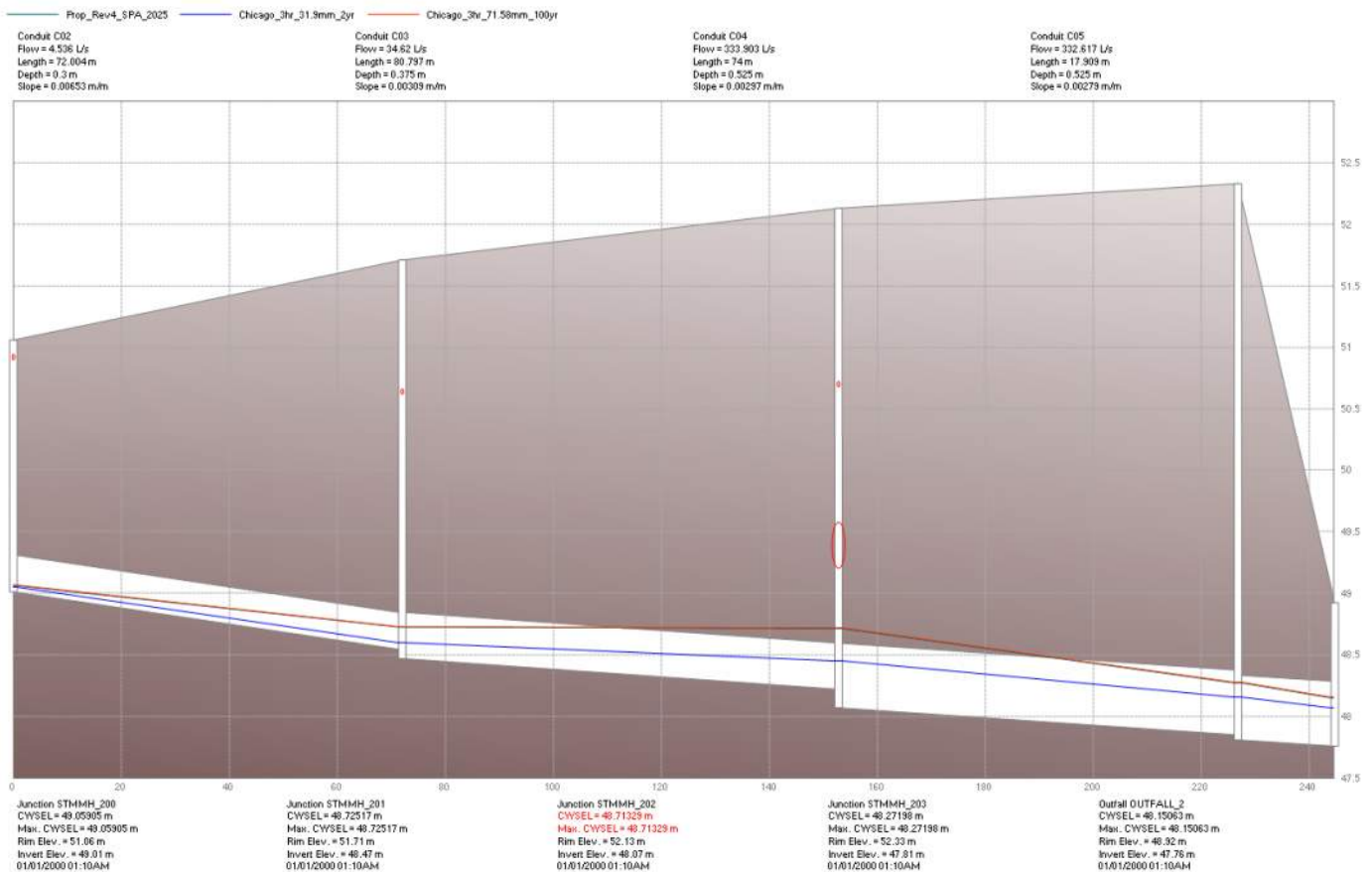

Figure 7-1: Hydraulic Grade Lines of 2-yr and 100-yr Storms of Jeanne-d’Arc Storm Sewers

Based on this analysis, we can confirm that the Jeanne-d’Arc storm sewer system will handle the runoffs from the 2-year storm without surcharging, and the maximum 100-year HGL will increase but no significant impact on the sewer capacity.

7.11 Tweddle Road Drainage Catchment

In response to comments received during the pre-consultation meeting, Tweddle Road north of Jeanne-d’Arc Blvd will be re-constructed to reduce the longitudinal slope and provide access to proposed development at 1015 Tweddle Road.

Additionally, the existing 900 mm diameter culvert crossing Jeanne-d’Arc Blvd near Tweddle Rd will be removed. As a result, runoff from the existing drainage catchment located at the southeast corner of the intersection of Jeanne-d’Arc Blvd and Tweddle Rd will be redirected to the roadside ditch along south of Jeanne-d’Arc Blvd. a new 500mm diameter HDPE culver will be installed to convey this flow across Tweddle Rd to the existing roadside ditch, ultimately discharging to the Ottawa River.

Six (6) subcatchments are shown on **Figure A3** with average runoff coefficients calculated for each drainage area.

- Runoff from the existing drainage subcatchment southeast of the intersection of Jeanne-d’Arc and Tweddle (S205), will be redirected to the existing roadside ditch east of Tweddle Rd and will be discharged to the Ottawa River at Taylor Creek outfall (Outfall #3). This will be facilitated by the installation of a 500 mm diameter HDPE culvert crossing Tweddle Rd.
- Runoff from the development site (S102 & S103) will overflow toward Tweddle Rd and discharge to the Ottawa River at Outfall #1A.
- Runoff from west half of Tweddle Rd (S300) will be collected by the street gutters and discharge to the Ottawa River at Outfall #4.
- Runoff from east half of Tweddle Rd (S301 & S303) will be collected by the street gutters and discharge to the Ottawa River at Outfall #1A.

Table 7-8 summarizes the modeled peak flows at the key outfalls under various design storm events.

Table 7-8 : Summary of Post-Development Flows at Outfalls #1A, 3, and 4

Storm Event	Peak Flow (L/sec)		
	Outfall #1A	Outfall #3	Outfall #4
Chicago_3h_2yr	42.0	50.3	13.9
Chicago_3h_5yr	88.1	74.0	18.9
Chicago_3h_100yr	426.3	153.1	32.3
Chicago_3h_100yr + 20%	636.8	196.4	38.8

Figure 7-2 below illustrates flows and water depths at the proposed 500 mm diameter HDPE culvert crossing Tweddle Rd.

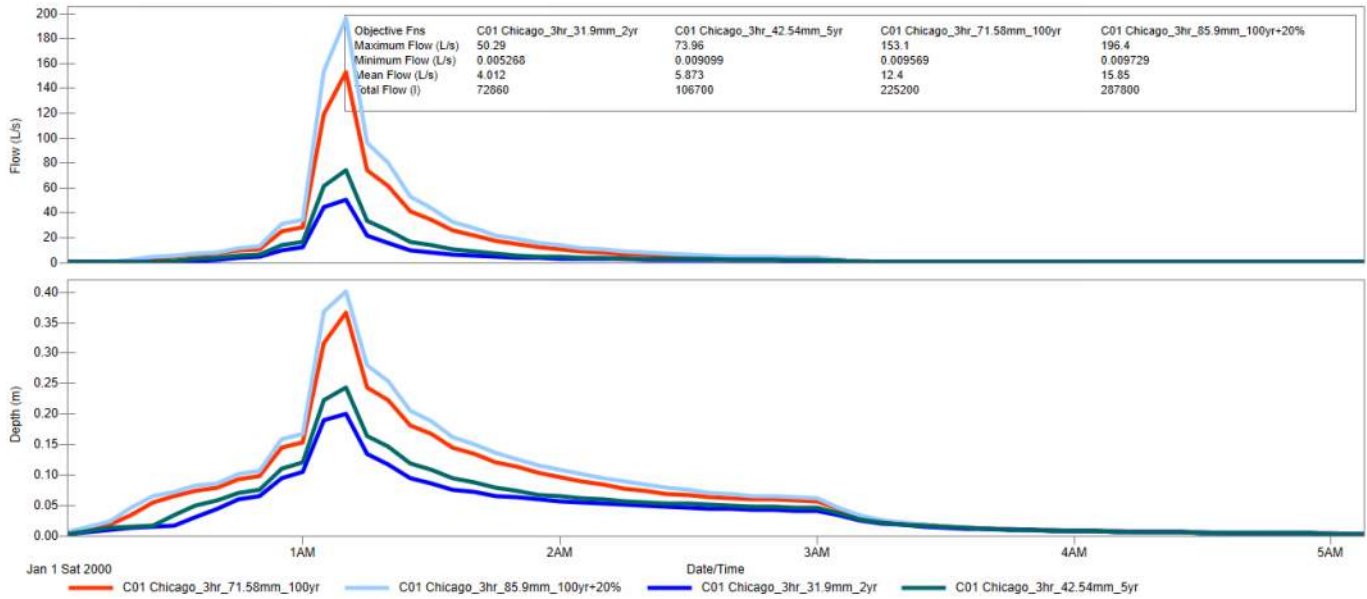

Figure 7-2: Flows and Water Depths at 500mm Culvert

Modeling results indicated that the proposed 500mm diameter HDPE culvert has sufficient capacity to convert runoffs from the drainage subcatchment to the existing road ditch west of Tweddle Rd.

8 Erosion & Sediment Control

During all construction activities, erosion and sedimentation shall be controlled by the following techniques:

- Filter cloth shall be installed between the frame and cover of all adjacent catch basins and catch basin manhole structures.
- Heavy duty silt fencing will be used to control runoff around the construction area. Silt fencing locations are identified on the site grading and erosion control plan.
- A mud mat will be installed at the construction entrance to help avoid mud from being transported to offsite roads.
- Visual inspection shall be completed daily on sediment control barriers and any damage repaired immediately. Care will be taken to prevent damage during construction operations.
- In some cases, barriers may be removed temporarily to accommodate the construction operations. The affected barriers will be reinstated at night when construction is completed.
- Sediment control devices will be cleaned of accumulated silt as required. The deposits will be disposed of as per the requirements of the contract.
- During the course of construction, if the engineer believes that additional prevention methods are required to control erosion and sedimentation, the contractor will install additional silt fences or other methods as required to the satisfaction of the engineer.
- Construction and maintenance requirements for erosion and sediment controls are to comply with Ontario Provincial Standard Specification (OPSS) OPSS 805 and City of Ottawa specifications.

9 Conclusions and Recommendations

This Functional Servicing & Stormwater Report outlines the rationale which will be used to service the proposed development. The following summarizes the servicing requirements for the site:

Water

- Two twin 200mm watermains are proposed to service the development, as the average day demands exceed 50 m³ per day, which is mandatory as per Section 4.31 of the WDG001.
- The Required Fire Flows (RFFs) were estimated at **7,000 L/min** (117 L/sec) for Tower B1, **7,000 L/min** (117 L/sec) for Tower B2, **7,000 L/min** (117 L/sec) for Tower B3 and **6,000 L/min** (100 L/sec) for Tower B4. The total minimum available flows for firefighting purposes, based on the contribution from hydrants, was estimated at **7,600 L/min, 15,200 L/min, 13,300 L/min and 9,500 L/min** for each building, respectively.
- Based on hydraulic boundary conditions (HGL) provided by the City of Ottawa, the maximum HGL indicates pressures greater than 80 psi, exceeding the City's guideline, therefore pressure reducing measures will be required.

Sewage

- Estimated peak sewage flows of **20.50 L/sec** are anticipated. A review of the sanitary sewers on Jeanne D'Arc Boulevard was completed. It was determined that the sanitary main between MHSA 22037 and MHSA 54993 will be re-routed and upsized from 300mm diameter to 375mm diameter pipes to match with the downstream pipes.

Stormwater

- Total pre-development discharge rate from the development area of the site was calculated based on a runoff coefficient of 0.29 and a time of concentration of 10 minutes. Pre-development discharge rates from the 1.28 ha development area were estimated to be **79.1 L/sec, 107.3 L/sec and 229.9 L/sec** during 2-year, 5-year and 100-year storm events, respectively.
- Post-development discharge rates from the development area were estimated to **222.4 L/sec, 320.4 L/sec and 572.7 L/sec** during 2-year, 50-year and 100-year storm events, respectively.
- The City did not impose onsite quantity control due to the proximity to the Ottawa River. This is contingent on using a direct connection to the river rather than discharging to a storm sewer.
- An oil-grit separator (OG) is required to meet the TSS removal efficiency of 80%. A Stormceptor Model EF05 was selected which is estimated to have a removal efficiency of **83%**.

Legal Notification

This report was prepared by EXP Services Inc. for the account of Trim 1 GP Inc.

Any use which a third party makes of this report, or any reliance on or decisions to be made based on it, are the responsibility of such third parties. EXP Services Inc. accepts no responsibility for damages, if any, suffered by any third party as a result of decisions made or actions based on this project.

Appendix A – Figures

Figure A1 – Post-Development Subcatchments

Figure A2 – JDA Subcatchments

Figure A3 – Tweddle Subcatchments



FIG A1: POST-DEVELOPMENT SUBCATCHMENT



FIG A2: JDA SUB-CATCHMENTS



FIG A3: TWEDDLE SUBCATCHMENTS

Appendix B – Design Tables

Table B1 – Water Demand Chart

Table B2 – Summary of Required Fire Flows (RFFs)

Table B3 – Fire Flow Requirements Based on Fire Underwriters Survey (FUS) – Tower B1

Table B4 – Fire Flow Requirements Based on Fire Underwriters Survey (FUS) – Tower B2

Table B5 – Fire Flow Requirements Based on Fire Underwriters Survey (FUS) – Tower B3

Table B6 – Fire Flow Requirements Based on Fire Underwriters Survey (FUS) – Tower B4

Table B7 – Fire Flow Requirements Based on Hydrant Spacing

Table B8 – Sanitary Sewer Design Sheet

Table B9 – Storm Sewer Design Sheet

Table B10 – Calculation of Average Runoff Coefficients for Pre-Development Conditions

Table B11 – Calculation of Catchment Time of Concentration for Pre-Development Conditions

Table B12 – Calculation of Peak Runoff for Pre-Development Conditions



TABLE B1: Water Demand Chart

(Building)	No. of Units									Total Pop	Residential Demands					Commercial				Total Demands in (L/sec)				
	Singles/Semis/Towns				Apartments						Avg Day Demand (L/day)	Max Day Peaking Factor	Max Hour Peaking Factor	Max Day Demand (L/day)	Peak Hourly Demand (L/day)	Area (ha)	Avg Demand (L/day)	Peaking Factors (x Avg Day)		Max Day Demand (L/day)	Peak Hour Demand (L/day)	Avg Day (L/s)	Max Day (L/s)	Peak Hour (L/s)
	Single Family	Semi	Duplex	Townhome	1-Bed Apt	1-Bed+Den Apt	2 Bed Apt	3 Bed Apt	Avg Apt.									Max Day	Peak Hour					
B1					53	163	107	3		536.4	150,192	2.5	5.5	375,480	826,056	0.1459	4,085	1.5	1.8	6127.8	7353.4	1.79	4.42	9.65
B2					62	186	123	1		608.6	170,408	2.5	5.5	426,020	937,244	0.1255	3,514	1.5	1.8	5271.0	6325.2	2.01	4.99	10.92
B3					51	167	104	1		526.7	147,476	2.5	5.5	368,690	811,118	0.1313	3,676	1.5	1.8	5514.6	6617.5	1.75	4.33	9.46
B4					144	92				330.4	92,512	2.5	5.5	231,280	508,816							1.07	2.68	5.89
Totals =					310	608	334	5		2002.1	560,588			1,401,470	3,083,234					16,913	20,296	6.62	16.42	35.92
Unit Densities	Persons/Unit		Residential																					
Singles	3.4		Residential Consumption (L/pers/day) = 280																					
Semi-Detached	2.7		Max Day Peaking Factor (* avg day) = 2.5																					
Duplex	2.3		Peak Hour Factor (* avg day) = 5.5																					
Townhome	2.7																							
Bachelor Apt Unit	1.4		Industrial/Commercial/Institutional Water Consumption																					
1-Bed Apt Unit	1.4		Light Industrial (L/gross ha/day) = 35,000																					
1-Bed + Den Apt Unit	1.4		Heavy Industrial (L/gross ha/day) = 55,000																					
2-Bed Apt Unit	2.1		Commer/Instit (L/gross ha/day) = 28,000																					
3-Bed Apt Unit	3.1		Max Day Peaking Factor (* avg day) = 1.5																					
Avg. Apt Unit	1.8		Peak Hour Factor (* avg day) = 1.8																					
			Project:																					
			249629 - 1015 Tweddle Road																					
			Designed:								Location:													
			A.Salem, P.Eng.								Ottawa, Ontario													
			Checked:																					
			B. Thomas, P.Eng.																					
			File Reference:								Page No:													
			259629 Water Demand Chart, March 2026.xlsx								1 of 1													

TABLE B2

SUMMARY OF REQUIRED FIREFLOWS (RFFs)

Building #	Description	¹ No of Storeys	Fire Flow, F (L/min)	² Type of Constr. Coeff, C	³ Reduction Due to Occupancy (%)	⁴ Reduction Due to Sprinklers (%)	⁵ Total Increase due to Exposures (%)	⁶ Required Fire Flow in	
								(L/min)	(L/sec)
Tower B1	high-rise condo	28	15,000	0.8	-15%	-50%	5%	7,000	117
Tower B2	high-rise condo	32	14,000	0.8	-15%	-50%	10%	7,000	117
Tower B3	high-rise condo	28	14,000	0.8	-15%	-50%	10%	7,000	117
Tower B4	high-rise condo	24	13,000	0.8	-15%	-50%	5%	6,000	100

Notes

1 - If basements are included (<50% below grade) then denoted as +.

2 - Types of constructions: 0.8 for non-combustible, 1.0 for ordinary construction, 1.5 for wood frame construction.

3 - Reductions due to Occupancy are -25% for non-combustible or -15% for limited combustible.

4 - Reductions due to Sprinkler Systems

5 - Increase due to exposures were calculated based on FUS 2020.

6 - Required Fire Flows are rounded to nearest 1,000 L/min.

TABLE B3 (Tower B1)
FIRE FLOW REQUIREMENTS BASED ON FIRE UNDERWRITERS SURVEY(FUS) 2020
 PROJECT: 1015 Tweddle Road
 Building No: **Tower B1**



An estimate of the Fire Flow required for a given fire area may be estimated by:

$$F = 220 * C * \text{SQRT}(A)$$

where:
 F = required fire flow in litres per minute
 A = total floor area in m² (including all storeys, but excluding basements at least 50% below grade)
 C = coefficient related to the type of construction

Task	Options	Multiplier	Input				Value Used	Fire Flow Total (L/min)
Choose Building Frame (C)	Wood Frame	1.5	Non-combustible Construction				0.8	
	Ordinary Construction	1						
	Non-combustible Construction	0.8						
	Fire Resistive Construction	0.6						
Input Building Floor Areas (A)			Area	% Used	Area Used	Comment	6982.0 m ²	
	Floor 11 to 28		928.0	0	0.0	Two largest adjoining floors + 50% of floors above (up to eight)		
	Floor 10		928.0	50%	464.0			
	Floor 9		928.0	50%	464.0			
	Floor 8		928.0	50%	464.0			
	Floor 7		928.0	50%	464.0			
	Floor 6		928.0	50%	464.0			
	Floor 5		928.0	50%	464.0			
	Floor 4		928.0	50%	464.0			
	Floor 3		928.0	50%	464.0			
	Floor 2		1570.0	100%	1570.0			
	Floor 1 (Main Level)		1700.0	100%	1700.0			
Basement (At least 50% below grade, not included)			0%	0.0				
Fire Flow (F)	F = 220 * C * SQRT(A)							14,706
Fire Flow (F)	Rounded to nearest 1,000							15,000

Reductions/Increases Due to Factors Effecting Burning

Task	Options	Multiplier	Input				Value Used	Fire Flow Change (L/min)	Fire Flow Total (L/min)					
Choose Combustibility of Building Contents	Non-combustible	-25%	Limited Combustible				-15%	-2,250	12,750					
	Limited Combustible	-15%												
	Combustible	0%												
	Free Burning	15%												
	Rapid Burning	25%												
Choose Reduction Due to Sprinkler System	Adequate Sprinkler Conforms to NFPA13	-30%	Adequate Sprinkler Conforms to NFPA13				-30%	-3,825	8,925					
	No Sprinkler	0%												
	Standard Water Supply for Fire Department Hose Line and for Sprinkler System	-10%	Standard Water Supply for Fire Department Hose Line and for Sprinkler System				-10%	-1,275	7,650					
	Not Standard Water Supply or Unavailable	0%												
	Fully Supervised Sprinkler System	-10%	Fully Supervised Sprinkler System				-10%	-1,275	6,375					
Choose Structure Exposure Distance			Separation Dist (m)	Cond	Separation Conditon	Exposed Wall type	Exposed Wall Length			Total Charge (%)	Total Exposure Charge (L/min)			
	Exposures					Length (m)	No of Storeys	Length-Height Factor	Sub-Conditon	Charge (%)				
	Side 1 (west)		46	5	30.1 to 45	Type IV-III (U)	0	0	0	6	0%	5%	638	7,013
	Side 2 (east)		25	4	20.1 to 30	Type IV-III (U)	38	28	1064	4F	5%			
	Front (north)		46	5	30.1 to 45	Type IV-III (U)	0	0	0	6	0%			
Back (south)		46	5	30.1 to 45	Type IV-III (U)	0	0	0	6	0%				
Obtain Required Fire Flow	Total Required Fire Flow, Rounded to the Nearest 1,000 L/min =											7,000		
	Total Required Fire Flow, L/s =											117		

Exposure Charges for Exposing Walls of Wood Frame Construcion (from Table G5)

Type V	Wood Frame
Type IV-III (U)	Mass Timber or Ordinary with Unprotected Openings
Type IV-III (P)	Mass Timber or Ordinary with Protected Openings
Type II-I (U)	Noncombustible or Fire Resistive with Unprotected Openings
Type II-I (P)	Noncombustible or Fire Resistive with Protected Openings

Conditons for Separation

Separation Dist	Condition
0m to 3m	1
3.1m to 10m	2
10.1m to 20m	3
20.1m to 30m	4
> 30.1m	5

TABLE B4 (Tower B2)

FIRE FLOW REQUIREMENTS BASED ON FIRE UNDERWRITERS SURVEY(FUS) 2020

PROJECT: 1015 Tweddle Road

Building No: **Tower B2**



An estimate of the Fire Flow required for a given fire area may be estimated by:

$$F = 220 * C * \text{SQRT}(A)$$

where:

F = required fire flow in litres per minute

A = total floor area in m² (including all storeys, but excluding basements at least 50% below grade)

C = coefficient related to the type of construction

Task	Options	Multiplier	Input				Value Used	Fire Flow Total (L/min)
Choose Building Frame (C)	Wood Frame	1.5	Non-combustible Construction				0.8	
	Ordinary Construction	1						
	Non-combustible Construction	0.8						
	Fire Resistive Construction	0.6						
Input Building Floor Areas (A)			Area	% Used	Area Used	Comment	6668.0 m ²	
	Floor 11 to 32		928.0	0	0.0	Two largest adjoining floors + 50% of floors above (up to eight)		
	Floor 10		928.0	50%	464.0			
	Floor 9		928.0	50%	464.0			
	Floor 8		928.0	50%	464.0			
	Floor 7		928.0	50%	464.0			
	Floor 6		928.0	50%	464.0			
	Floor 5		928.0	50%	464.0			
	Floor 4		928.0	50%	464.0			
	Floor 3		928.0	50%	464.0			
	Floor 2		1478.0	100%	1478.0			
	Floor 1 (Main Level)		1478.0	100%	1478.0			
Basement (At least 50% below grade, not included)			0%	0.0				
Fire Flow (F)	F = 220 * C * SQRT(A)						14,372	
Fire Flow (F)	Rounded to nearest 1,000						14,000	

Reductions/Increases Due to Factors Effecting Burning

Task	Options	Multiplier	Input				Value Used	Fire Flow Change (L/min)	Fire Flow Total (L/min)								
Choose Combustibility of Building Contents	Non-combustible	-25%	Limited Combustible				-15%	-2,100	11,900								
	Limited Combustible	-15%															
	Combustible	0%															
	Free Burning	15%															
	Rapid Burning	25%															
Choose Reduction Due to Sprinkler System	Adequate Sprinkler Conforms to NFPA13	-30%	Adequate Sprinkler Conforms to NFPA13				-30%	-3,570	8,330								
	No Sprinkler	0%															
	Standard Water Supply for Fire Department Hose Line and for Sprinkler System	-10%	Standard Water Supply for Fire Department Hose Line and for Sprinkler System				-10%	-1,190	7,140								
	Not Standard Water Supply or Unavailable	0%															
	Fully Supervised Sprinkler System	-10%	Fully Supervised Sprinkler System				-10%	-1,190	5,950								
Choose Structure Exposure Distance	Exposures	Separation Dist (m)	Cond	Separation Conditon	Exposed Wall type	Exposed Wall Length				Total Charge (%)	Total Exposure Charge (L/min)						
						Length (m)	No of Storeys	Length-Height Factor	Sub-Conditon								
						Side 1 (west)	25	4	20.1 to 30			Type IV-III (U)	42	28	1176	4F	5%
						Side 2 (east)	25.6	4	20.1 to 30			Type IV-III (U)	40	28	1120	4F	5%
						Front (north)	46	5	30.1 to 45			Type IV-III (U)	0	0	0	6	0%
Back (south)	46	5	30.1 to 45	Type IV-III (U)	0	0	0	6	0%								
Obtain Required Fire Flow	Total Required Fire Flow, Rounded to the Nearest 1,000 L/min =							7,000									
	Total Required Fire Flow, L/s =							117									

Exposure Charges for Exposing Walls of Wood Frame Constructon (from Table G5)

Type V	Wood Frame
Type IV-III (U)	Mass Timber or Ordinary with Unprotected Openings
Type IV-III (P)	Mass Timber or Ordinary with Protected Openings
Type II-I (U)	Noncombustible or Fire Resistive with Unprotected Openings
Type II-I (P)	Noncombustible or Fire Resistive with Protected Openings

Conditons for Separation

Separation Dist	Condition
0m to 3m	1
3.1m to 10m	2
10.1m to 20m	3
20.1m to 30m	4
> 30.1m	5

TABLE B5 (Tower B3)

FIRE FLOW REQUIREMENTS BASED ON FIRE UNDERWRITERS SURVEY(FUS) 2020

PROJECT: 1015 Tweddle Road

Building No: **Tower B3**



An estimate of the Fire Flow required for a given fire area may be estimated by:

$$F = 220 * C * \text{SQRT}(A)$$

where:

F = required fire flow in litres per minute

A = total floor area in m² (including all storeys, but excluding basements at least 50% below grade)

C = coefficient related to the type of construction

Task	Options	Multiplier	Input				Value Used	Fire Flow Total (L/min)
Choose Building Frame (C)	Wood Frame	1.5	Non-combustible Construction				0.8	
	Ordinary Construction	1						
	Non-combustible Construction	0.8						
	Fire Resistive Construction	0.6						
Input Building Floor Areas (A)			Area	% Used	Area Used	Comment	6730.0 m ²	
	Floor 11 to 28		928.0	0	0.0	Two largest adjoining floors + 50% of floors above (up to eight)		
	Floor 10		928.0	50%	464.0			
	Floor 9		928.0	50%	464.0			
	Floor 8		928.0	50%	464.0			
	Floor 7		928.0	50%	464.0			
	Floor 6		928.0	50%	464.0			
	Floor 5		928.0	50%	464.0			
	Floor 4		928.0	50%	464.0			
	Floor 3		928.0	50%	464.0			
	Floor 2		1405.0	100%	1405.0			
	Floor 1 (Main Level)		1613.0	100%	1613.0			
Basement (At least 50% below grade, not included)			0%	0.0				
Fire Flow (F)	F = 220 * C * SQRT(A)						14,438	
Fire Flow (F)	Rounded to nearest 1,000						14,000	

Reductions/Increases Due to Factors Effecting Burning

Task	Options	Multiplier	Input				Value Used	Fire Flow Change (L/min)	Fire Flow Total (L/min)				
Choose Combustibility of Building Contents	Non-combustible	-25%	Limited Combustible				-15%	-2,100	11,900				
	Limited Combustible	-15%											
	Combustible	0%											
	Free Burning	15%											
	Rapid Burning	25%											
Choose Reduction Due to Sprinkler System	Adequate Sprinkler Conforms to NFPA13	-30%	Adequate Sprinkler Conforms to NFPA13				-30%	-3,570	8,330				
	No Sprinkler	0%											
	Standard Water Supply for Fire Department Hose Line and for Sprinkler System	-10%	Standard Water Supply for Fire Department Hose Line and for Sprinkler System				-10%	-1,190	7,140				
	Not Standard Water Supply or Unavailable	0%											
	Fully Supervised Sprinkler System	-10%	Fully Supervised Sprinkler System				-10%	-1,190	5,950				
Choose Structure Exposure Distance	Exposures	Separation Dist (m)	Cond	Separation Conditon	Exposed Wall type	Exposed Wall Length	Total Charge (%)	Total Exposure Charge (L/min)					
						Length (m)	No of Storeys	Length-Height Factor	Sub-Conditon	Charge (%)			
	Side 1 (west)	25.6	4	20.1 to 30	Type IV-III (U)	31	28	868	4F	5%	10%	1,190	7,140
	Side 2 (east)	22	4	20.1 to 30	Type IV-III (U)	26	24	624	4F	5%			
	Front (north)	46	5	30.1 to 45	Type IV-III (U)	0	0	0	6	0%			
Back (south)	46	5	30.1 to 45	Type IV-III (U)	0	0	0	6	0%				
Obtain Required Fire Flow	Total Required Fire Flow, Rounded to the Nearest 1,000 L/min =											7,000	
	Total Required Fire Flow, L/s =											117	

Exposure Charges for Exposing Walls of Wood Frame Construcion (from Table G5)

Type V	Wood Frame
Type IV-III (U)	Mass Timber or Ordinary with Unprotected Openings
Type IV-III (P)	Mass Timber or Ordinary with Protected Openings
Type II-I (U)	Noncombustible or Fire Resistive with Unprotected Openings
Type II-I (P)	Noncombustible or Fire Resistive with Protected Openings

Conditons for Separation

Separation Dist	Condition
0m to 3m	1
3.1m to 10m	2
10.1m to 20m	3
20.1m to 30m	4
> 30.1m	5

TABLE B6 (Tower B4)

FIRE FLOW REQUIREMENTS BASED ON FIRE UNDERWRITERS SURVEY(FUS) 2020

PROJECT: 1015 Tweddle Road

Building No: **Tower B4**



An estimate of the Fire Flow required for a given fire area may be estimated by:

$$F = 220 * C * \text{SQRT}(A)$$

where:

F = required fire flow in litres per minute

A = total floor area in m² (including all storeys, but excluding basements at least 50% below grade)

C = coefficient related to the type of construction

Task	Options	Multiplier	Input				Value Used	Fire Flow Total (L/min)
Choose Building Frame (C)	Wood Frame	1.5	Non-combustible Construction				0.8	
	Ordinary Construction	1						
	Non-combustible Construction	0.8						
	Fire Resistive Construction	0.6						
Input Building Floor Areas (A)			Area	% Used	Area Used	Comment	5279.0 m ²	
	Floor 11 to 28		900.0	0	0.0	Two largest adjoining floors + 50% of floors above (up to eight)		
	Floor 10		900.0	50%	450.0			
	Floor 9		900.0	50%	450.0			
	Floor 8		900.0	50%	450.0			
	Floor 7		900.0	50%	450.0			
	Floor 6		900.0	50%	450.0			
	Floor 5		900.0	50%	450.0			
	Floor 4		900.0	50%	450.0			
	Floor 3		900.0	50%	450.0			
	Floor 2		897.0	100%	897.0			
	Floor 1 (Main Level)		782.0	100%	782.0			
Basement (At least 50% below grade, not included)			0%	0.0				
Fire Flow (F)	F = 220 * C * SQRT(A)							12,788
Fire Flow (F)	Rounded to nearest 1,000							13,000

Reductions/Increases Due to Factors Effecting Burning

Task	Options	Multiplier	Input				Value Used	Fire Flow Change (L/min)	Fire Flow Total (L/min)				
Choose Combustibility of Building Contents	Non-combustible	-25%	Limited Combustible				-15%	-1,950	11,050				
	Limited Combustible	-15%											
	Combustible	0%											
	Free Burning	15%											
	Rapid Burning	25%											
Choose Reduction Due to Sprinkler System	Adequate Sprinkler Conforms to NFPA13	-30%	Adequate Sprinkler Conforms to NFPA13				-30%	-3,315	7,735				
	No Sprinkler	0%	Standard Water Supply for Fire Department Hose Line and for Sprinkler System				-10%	-1,105	6,630				
	Standard Water Supply for Fire Department Hose Line and for Sprinkler System	-10%											
	Not Standard Water Supply or Unavailable	0%											
	Fully Supervised Sprinkler System	-10%	Fully Supervised Sprinkler System				-10%	-1,105	5,525				
Not Fully Supervised or N/A	0%												
Choose Structure Exposure Distance	Exposures	Separation Dist (m)	Cond	Separation Conditon	Exposed Wall type	Exposed Wall Length	Total Charge (%)	Total Exposure Charge (L/min)					
	Side 1 (west)	46	4	20.1 to 30	Type IV-III (U)	Length (m)	No of Storeys	Length-Height Factor	Sub-Conditon	Charge (%)	5%	553	6,078
	Side 2 (east)	25	5	30.1 to 45	Type IV-III (U)	35	24	840	4F	5%			
	Front (north)	46	5	30.1 to 45	Type IV-III (U)	0	0	0	6	0%			
	Back (south)	46	5	30.1 to 45	Type IV-III (U)	0	0	0	6	0%			
Obtain Required Fire Flow	Total Required Fire Flow, Rounded to the Nearest 1,000 L/min =											6,000	
	Total Required Fire Flow, L/s =											100	

Exposure Charges for Exposing Walls of Wood Frame Construcion (from Table G5)

Type V	Wood Frame
Type IV-III (U)	Mass Timber or Ordinary with Unprotected Openings
Type IV-III (P)	Mass Timber or Ordinary with Protected Openings
Type II-I (U)	Noncombustible or Fire Resistive with Unprotected Openings
Type II-I (P)	Noncombustible or Fire Resistive with Protected Openings

Conditons for Separation

Separation Dist	Condition
0m to 3m	1
3.1m to 10m	2
10.1m to 20m	3
20.1m to 30m	4
> 30.1m	5

TABLE B7

FIRE FLOW REQUIREMENTS BASED ON HYDRANT SPACING

Hydrant #	Tower B1		Tower B2		Tower B3		Tower B4	
	¹ Distance (m)	² Fire Flow Contribution (L/min)	¹ Distance (m)	² Fire Flow Contribution (L/min)	¹ Distance (m)	² Fire Flow Contribution (L/min)	¹ Distance (m)	² Fire Flow Contribution (L/min)
New FH	40	5,700	117	3,800	174	0	231	0
H030	125	3,800	140	3,800	185	0	276	0
H031	146	3,800	40	5,700	101	3,800	160	0
H001	180	0	47	5,700	42	5,700	111	3,800
H002	300	0	170	0	105	3,800	43	5,700
Total (L/min)		13,300		19,000		13,300		9,500
FUS RFF in L/min or (L/sec)		7,000 (117)		7,000 (117)		7,000 (117)		6,000 (100)
Meets Requirement (Yes/No)		Yes		Yes		Yes		Yes
<p><u>Notes:</u> ¹Distance is measured along a road or fire route. ²Fire Flow Contribution for Class AA Hydrant from Table 1 of Appendix I, ISTB-2018-02</p>								

**TABLE B8
SANITARY SEWER CALCULATION SHEET**

LOCATION				RESEDENTIAL AREAS AND POPULAITONS													COMMERCIAL					INFILTRATION			SEWER DATA												
Street	U/S MH	D/S MH	Desc	Area (ha)	ACCU Area (ha)	NUMBER OF UNITS						Total Units	POPULATION		Peak Factor	Peak Flow (L/sec)	AREA (ha)			Comm Peak Factor	Peak Flow (L/sec)	AREA (ha)		INFILT FLOW (L/s)	TOTAL FLOW (L/s)	Nom Dia (mm)	Actual Dia (mm)	Type	Slope (%)	Length (m)	Capacity (L/sec)	Q/Q _{CAP} (%)	Full Velocity (m/s)				
						Single	Semis	Towns	Batch Apt.	1-Bed Apt.	1-Bed + Den Apt.		2-Bed Apt.	3-Bed Apt.			INDIV	ACCU	INDIV			ACCU	% of total											INDIV	ACCU		
Petrie's Landing		MHSA54989	Towers 1-6		3.919					132	721		365	14	1232	2004.1	2004.1	3.07	19.94	0.301	0.301	8%	1.0	0.10	3.92	3.919	1.29	21.33									
Jeane D'Arc Blvd North	MHSA54989	MHSA54990			3.919											2004.1		3.07	19.94		0.301				3.919	1.29	21.23	300	299.36	PVC	0.15	79.36	37.24	0.57	0.52		
	MHSA54990	MHSA54991			3.919											2004.1		3.07	19.94		0.301				3.919	1.29	21.23	300	299.36	PVC	0.29	34.70	51.62	0.41	0.73		
	MHSA54991	MHSA54992			3.919											2004.1		3.07	19.94		0.301				3.919	1.29	21.23	300	299.36	PVC	0.16	85.00	39.02	0.54	0.55		
	MHSA54992	SAMH101	EXT-1	1.1350	5.054											2004.10		3.07	19.94		0.301			1.135	5.054	1.67	21.61										
			EXT-2	4.8806	9.934											2004.10		3.07	19.94	4.881	5.182	49%	1.5	2.52	4.881	9.934	3.28	25.74									
			Towers B4	0.1960	10.1304								144	92	236	330.4	2334.50	3.03	22.92						0.196	10.130	3.34	26.27									
			Towers B3	0.2420	10.3724								51	167	104	1	323	526.7	2.97	27.54	0.131	5.313	54%	1.5	2.58	0.242	10.372	3.42	33.54	375	388.62	PVC	0.16	26.18	77.13	0.43	0.65
	SAMH101	SAMH100	Towers B2	0.3480	10.7204								62	186	123	1	372	608.6	2.91	32.72	0.126	5.438	36%	1.5	2.64	0.348	10.720	3.54	38.90								
			Towers B1	0.3720	11.0924								53	163	107	3	326	536.4	2.87	37.26	0.146	5.584	39%	1.5	2.71	0.372	11.092	3.66	43.64	375	388.62	PVC	0.19	71.30	84.05	0.52	0.70
	SAMH100	MHSA22037			11.0924											4006.20		2.87	37.26		5.584		1.5	2.71		11.092	3.66	43.64	375	388.62	PVC	0.18	24.85	81.81	0.53	0.68	
	MHSA22037	MHSA22036			11.0924											4006.2		2.87	37.26		5.584		1.5	2.71		11.092	3.66	43.64	375	381	CONC	0.30	44.00	100.18	0.44	0.87	
	MHSA22036	MHSA22035			11.0924											4006.2		2.87	37.26		5.584		1.5	2.71		11.092	3.66	43.64	375	381	CONC	0.30	104.40	100.18	0.44	0.87	
	MHSA22035	MHSA22028			11.0924											4006.2		2.87	37.26		5.584		1.5	2.71		11.092	3.66	43.64	375	381	CONC	0.31	104.50	101.84	0.43	0.89	
	MHSA22028	MHSA22027			11.0924											4006.2		2.87	37.26		5.584		1.5	2.71		11.092	3.66	43.64	375	381	CONC	0.38	5.30	112.75	0.39	0.98	
					11.0924											132	1031	608	699	19	2489	4006.2				5.584			11.092								843.9
Residential Avg. Daily Flow, q (L/p/day) =				280	Commercial Peak Factor =				1.5 (when area >20%)	Peak Population Flow, (L/sec) =				Persons/Unit				Designed:				Project:															
Commercial Avg. Daily Flow (L/gross ha/day) =				28,000	Institutional Peak Factor =				1.0 (when area <20%)	Peak Extraneous Flow, (L/sec) =				3.4				Jason Fitzpatrick, P.Eng.				1015 Tweddle Road (Formerly 1009 Trim Road)															
or L/gross ha/sec =				0.324	Residential Correction Factor, K =				0.80	Residential Peaking Factor, M =				2.7				Checked:				Location:															
Institutional Avg. Daily Flow (L/s/ha) =				28,000	Manning N =				0.013	A _c = Cumulative Area (hectares)				2.7				Bruce Thomas, P.Eng.				Ottawa, Ontario															
or L/gross ha/sec =				0.324	Peak extraneous flow, I (L/s/ha) =				0.33 (Total I/I)	P = Population (thousands)				1.4				File Reference:				Page No:															
Light Industrial Flow (L/gross ha/day) =				35,000									1.4				Copy of 259629 Sanitary - Sewer Design				1 of 1																
or L/gross ha/sec =				0.405092593									1.4				Sheet, March 2026.xlsx																				
Light Industrial Flow (L/gross ha/day) =				55,000									2.1																								
or L/gross ha/sec =				0.637									3.1																								

Notes
0.59 Existing sewer runs with velocity less than 0.60 m/sec (Section 6.1.2.2 of SDG002)

TABLE B9
STORM SEWER CALCULATION SHEET

Return Period Storm = 2-year
 Default Inlet Time= 10 (frontyard/row)
 Default Inlet Time= 15 (rearyard)
 Manning Coefficient = 0.013

Street	Storm MH No:		AREA INFO				PEAK FLOWS (UNRESTRICTED - RATIONAL METHOD)							SEWER DATA											
	U/S	D/S	Catchment No:	Area (ha)	Accum. Area (ha)	Runoff Coeff, C	Indiv. 2.78*A*R	Accum. 2.78*A*R	Tc (mins)	I (mm/h)	Indiv. Flow	Return Period	Q (L/s)	Diameter (mm)		Type	Slope (%)	Length (m)	Capacity, Q _{CAP} (L/sec)	Velocity (m/s)		Time in Pipe, Tt (min)	Hydraulic Ratios		
														Act	Nom					Vf	Va		Q/Q _{CAP}	Va/Vf	
Jeane D'Arc Blvd	ndn	201	S200	0.2265	0.2265	0.71	0.4471	0.4471	10.00	76.81	34.3	2-year	34.3												
			S100	0.0691	0.2956	0.63	0.1210	0.5681	10.00	76.81	9.3	2-year	43.6	299.4	300	PVC	0.65	72.00	77.52	1.10	0.78	1.54	0.56	0.71	
	201	202	S201	0.1793	0.4749	0.72	0.3589	0.9270	10.00	76.81	27.6	2-year	71.2												
			S101	0.0372	0.5121	0.65	0.0672	0.9942	11.54	71.37	4.8	2-year	71.0	366.4	375	PVC	0.30	80.78	90.28	0.87	0.85	1.58	0.79	0.98	
	202	203	S202	1.3325	1.8446	0.55	2.0374	3.0316	10.00	76.81	156.5	2-year	232.8												
			S203	0.3195	2.1641	0.44	0.3908	3.4224	10.00	76.81	30.0	2-year	262.9												
			S204	0.0366	2.2007	0.90	0.0916	3.5140	13.12	66.60	6.1	2-year	234.0	533.0	525	CONC	0.30	74.00	245.25	1.09	1.13	1.09	0.95	1.04	
	203	HW 1			2.2007			3.5140	14.21	63.71		2-year	223.9	533.0	525	CONC	0.27	16.61	232.66	1.03	1.07	0.26	0.96	1.04	
TOTALS =				2.2007		0.57	3.514					268.6													

Definitions: Q = 2.78*AIR, where Q = Peak Flow in Litres per second (L/s) A = Watershed Area (hectares) I = Rainfall Intensity (mm/h) R = Runoff Coefficients (dimensionless)	Ottawa Rainfall Intensity Values from Sewer Design Guidelines, SDG002			Designed:	Project:	
		<u>a</u>	<u>b</u>	<u>c</u>	J. Fitzpatrick, P.Eng.	1015 Tweedle Rd
	2-year	732.951	6.199	0.810	Checked:	Location:
	5-year	998.071	6.053	0.814	B. Thomas, P.Eng.	1015 Tweedle Rd
	100-year	1735.688	6.014	0.820	Dwg Reference:	File Ref:
				Drawing C401	259629 Storm - Sewer Design Sheet, Sept 2025.xlsx	Sheet No: 1 of 1

TABLE B10**CALCULATION OF AVERAGE RUNOFF COEFFICIENTS FOR PRE-DEVELOPMENT CONDITIONS**

Area No.	Roof Areas		Asphalt Areas		Concrete / Pavers		Gravel		Grassed Areas		Sum AC	Total Area (m ²)	C _{AVG}
	C=0.90		C=0.90		C=0.90		C=0.75		C=0.20				
	Area (m ²)	A * C	Area (m ²)	A * C	Area (m ²)	A * C	Area (m ²)	A * C	Area (m ²)	A * C			
Site							2091.69	1568.8	10685.32	2137.06	3705.8	12777.01	0.29

TABLE B11**CALCULATION OF CATCHMENT TIME OF CONCENTRATION FOR PRE-DEVELOPMENT CONDITIONS**

Catchment No.	Area (ha)	High Elev (m)	Low Elev (m)	Flow Path Length (m)	Indiv Slope	Avg. C	Time of Conc. Tc (mins)	Description
Site	1.278	48.5	46.2	78.3	2.9	0.29	3.58	See Note 1

Notes
1) For Catchments with Runoff Coefficient less than C=0.40, Time of Concentration Based on Federal Aviation Formula (Airport Method),
2) For Catchments with Runoff Coefficient greater than C=0.40, Time of Concentration Based on Bransby Williams Equation, from MTO

TABLE B12**CALCULATION OF PEAK RUNOFF FOR PRE-DEVELOPMENT CONDITIONS**

Area No	Outlet Location	Area (ha)	Time of Conc, Tc (min)	Storm = 2 yr			Storm = 5 yr			Storm = 100 yr		
				I ₂ (mm/hr)	Cavg	Q ₂ (L/sec)	I ₅ (mm/hr)	Cavg	Q ₅ (L/sec)	I ₁₀₀ (mm/hr)	Cavg	Q ₁₀₀ (L/sec)
Site	Ottawa River	1.278	10	76.81	0.29	79.1	104.19	0.29	107.3	178.56	0.36	229.9

Notes
1) Intensity, $I = 732.951 / (Tc + 6.199)^{0.810}$ (2-year, City of Ottawa)
2) Intensity, $I = 998.071 / (Tc + 6.053)^{0.814}$ (5-year, City of Ottawa)
3) Intensity, $I = 1735.688 / (Tc + 6.014)^{0.820}$ (100-year, City of Ottawa)
4) Cavg for 100-year is increased by 25% to a maximum of 1.0
5) The standard minimum Time of Concentration of 10 minutes was used, rather than the calculated time, since calculated time was less than 10 minutes.

Appendix C – Manufacturers Information

Stormceptor Sizing Report

Stormceptor EF Brochure

Stormceptor EF05 Detail

Stormceptor® EF



Stormceptor® EF Overview

About Imbrium® Systems

Imbrium® Systems is dedicated to protecting Canada's waterways. Based on our knowledge and experience in the Canadian stormwater industry, we have the ability to provide the most effective stormwater treatment technologies that capture and retain harmful pollutants from urban runoff before it enters our streams, rivers, lakes, and oceans.

Imbrium's engineered treatment solutions have been third-party tested and verified in accordance with the ISO 14034 Environmental Technology Verification (ETV) protocol to ensure performance in real-world conditions as designed. Our team of highly skilled engineers and partners provide the highest level of service from design to installation and long-term maintenance.

By working with Imbrium and our partners, you can expect superior treatment technology, unparalleled customer service, compliance with local stormwater regulations, and cleaner water. To find your local representative, please visit www.imbriumsystems.com/localrep.



Learn About the Stormceptor® EF

Go online and watch our animation to learn how the Stormceptor EF works. The animation highlights important features of the Stormceptor EF including:

- Functionality
- Applications
- Inspection and Maintenance

To view the Stormceptor EF animation, visit www.imbriumsystems.com/stormceptoref



Stormceptor® EF

A CONTINUATION AND EVOLUTION OF THE MOST GLOBALLY RECOGNIZED OIL GRIT SEPARATOR (OGS) STORMWATER TREATMENT TECHNOLOGY

Stormceptor EF effectively targets sediment (TSS), free oils, gross pollutants and other pollutants that attach to particles, such as nutrients and metals. Stormceptor EF's independently tested and verified, patent- pending treatment and scour prevention platform ensures pollutants are captured and contained during all rainfall events.

Stormceptor EF also offers design flexibility in one platform, accepting flow from a single inlet pipe, multiple inlet pipes, and from the surface through an inlet grate. Stormceptor EF can also accommodate a 90-degree inlet to outlet bend angle, and tailwater conditions.

Ideal Uses

- Sediment (TSS) removal
- Hydrocarbon control and hotspots (Stormceptor EF)
- Debris and small floatables capture
- Pretreatment for filtration, detention/retention systems, ponds, wetlands, and bioretention
- Retrofit and redevelopment projects

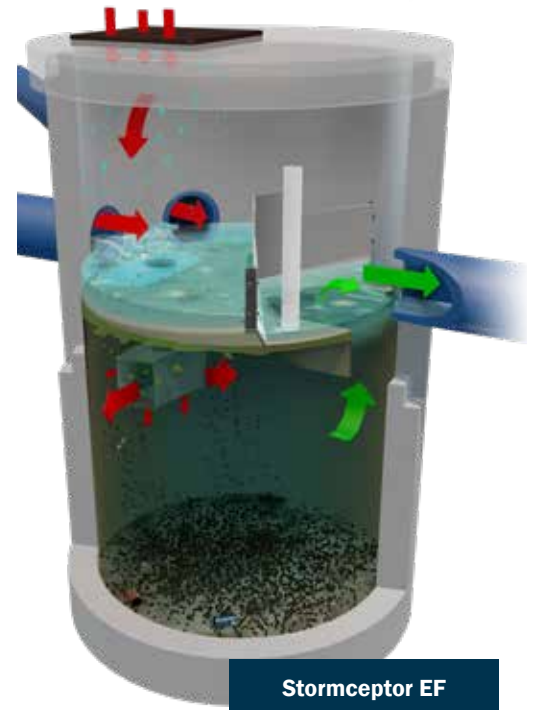

Stormceptor EF and Stormceptor EFO have been verified in accordance with ISO 14034 Environment Management - Environmental Technology Verification (ETV) protocol.

How the Stormceptor® EF Works

- Flow enters the Stormceptor through one or more inlet pipes or an inlet grate.
- A specially designed insert reduces influent velocity by creating a pond upstream of the weir, allowing sediments to begin settling.
- Swirling flow sweeps water and pollutants across the sloped insert surface to the drop pipe, where a strong vortex draws water, sediment, oil, and debris down the drop pipe cone and into the lower chamber.
- Flow exits the drop pipe through two large rectangular openings, while also diffusing through perforations in multiple directions. This reduces stream velocities and increases pollutant removal efficiency while preventing resuspension and washout of previously captured pollutants.
- Floatables, such as oil and gross pollutants, rise up and are trapped beneath the insert.
- Sediment settles to the sump.
- Treated stormwater discharges to the top side of the insert downstream of the weir, where it exits through the outlet pipe.
- During intense storm events excess influent passes over the weir and exits through the outlet pipe. The pond continues to separate sediment from all incoming flows, while full treatment in the lower chamber continues at the maximum flow rate, without scour of previously captured pollutants.

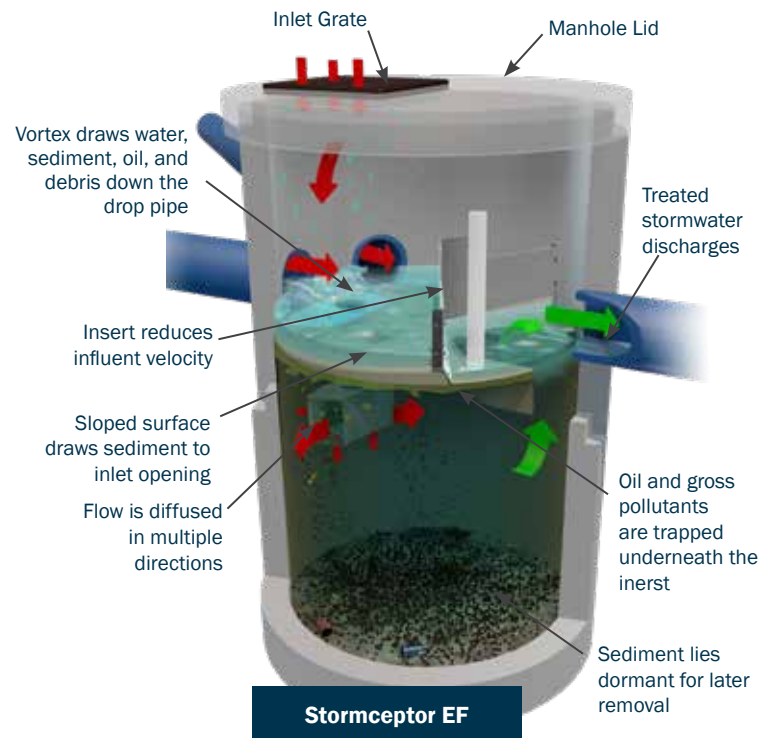

* Fiberglass system is an option

Stormceptor® EF Features & Benefits

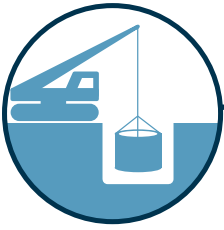

EASY TO INSTALL

Small footprint saves time and money with limited disruption to your site.

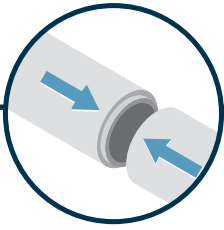

SEAMLESS

Minimal drop between inlet and outlet pipes makes Stormceptor ideal for retrofits and new development projects.

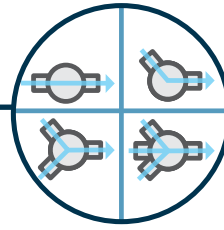

FLEXIBLE

Multiple inlets can connect to a single unit. Can be used as a bend structure.

FEATURES	BENEFITS
Patent-pending enhanced flow treatment and scour prevention technology	Superior, third-party verified performance
Third-party verified light liquid capture and retention (EFO version)	Proven performance for fuel/oil hotspot locations
Functions as bend, junction or inlet structure	Cost savings and design flexibility
Minimal drop between inlet and outlet	Site installation ease
Large diameter outlet riser for inspection and maintenance	Easy maintenance access from grade



Stormceptor® EF Standard Configurations

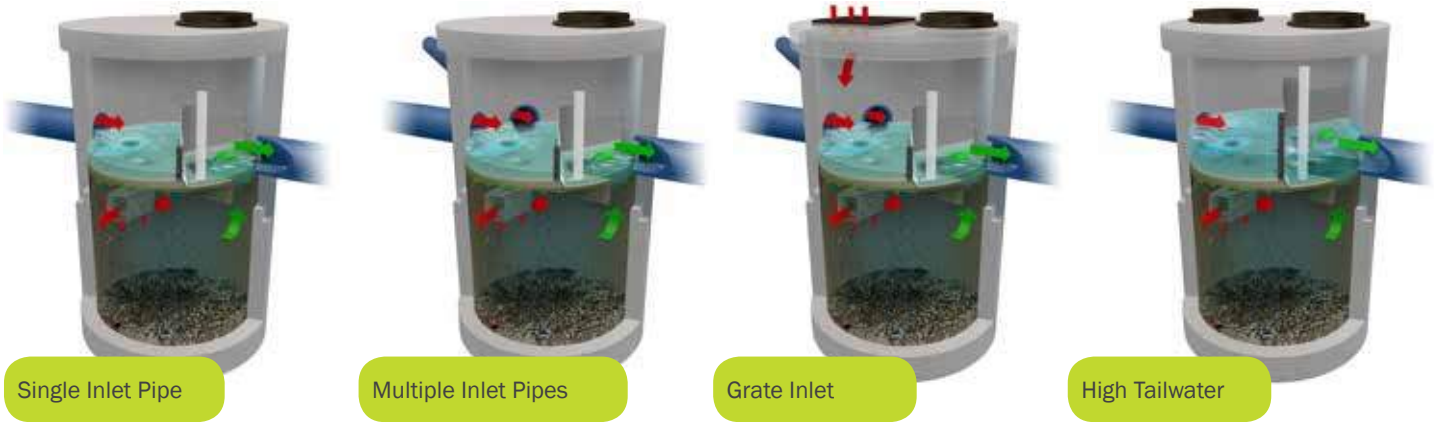

OPTIONS & ACCESSORIES

The following options and accessories are available for specific functions and site conditions:

- **Tailwater/Submerged Site** – For sites with standing water during dry weather periods, weir modifications can be implemented to ensure optimal performance.
- **Additional Sediment Storage Volume** – For sites with high pollutant loads or remote sites, additional sediment storage volume can easily be added.
- **Oil Alarm** – To mitigate spill liability, a monitoring system can be employed to trigger a visual and audible alarm when an oil or fuel spill occurs.
- **Additional Oil Capture** – A draw-off tank can be incorporated to increase spill storage capacity.
- **High Load** – Standard design loading is CHBDC or AASHTO H-20. Specialized loading can be designed to withstand very high loadings typical of airports and port facilities.
- **Lightweight** – Sites that required lightweight or above ground units are available as complete fiberglass systems.



For any of these options or accessories, please contact your Stormceptor representative for design assistance.

Stormceptor® EFO

Accidents and spills happen, whether it is a fueling station, port, industrial site, or general hot spot with daily vehicle traffic. Protect the environment and your site from potentially costly clean-up, remediation, litigation and fines with the Stormceptor EFO configuration.

The Stormceptor EFO has been third-party tested to ensure oil capture, and retention during high flow events. The hydraulics of the Stormceptor EFO have been optimized to enhance oil and hydrocarbon capture.

STORMCEPTOR EFO – HYDROCARBON SPILL PROTECTION

- Stormceptor EFO configuration has been third-party performance tested for safe oil capture and retention.
- Patent-pending technology ensures captured oil and sediment are retained even during the largest rain events, for secure storage, environmental protection and easy removal.
- Stormceptor EFO provides double wall containment for captured hydrocarbons.
- Stormceptor EFO is ideal for gas stations, fuel depots, ports, garages, loading docks, industrial sites, fast food locations, high-collision intersections and other hotspots with spill-prone areas.
- Stormceptor EFO can accommodate an optional oil alarm and additional storage to increase spill storage capacity.

Stormceptor® Inspection & Maintenance

Conducted at grade, the Stormceptor EF design makes inspection and maintenance an easy and inexpensive process. Once maintained, the Stormceptor EF is functionally restored as designed, with full pollutant capture capacity.

MAINTENANCE RECOMMENDATIONS:

- Inspect every six months for the first year to determine the pollutant accumulation rate.
- In subsequent years, inspections can be based on observations or local requirements.
- Inspect the unit immediately after an oil, fuel or chemical spill. A licensed waste management company should remove oil and sediment, and dispose responsibly.



Stormceptor maintenance is performed at grade with a standard vacuum truck



FILTERRA BIORETENTION

The Filterra® Bioretention System is an engineered biofiltration device with components that make it similar to bioretention in pollutant removal and application, but has been optimized for high volume/flow treatment in a compact system.



JELLYFISH FILTER

The Jellyfish® Filter is a stormwater treatment technology featuring pretreatment and membrane filtration in a compact stand-alone treatment system that removes a high level and a wide variety of stormwater pollutants.



LITTATRAP CATCH BASIN

The LittaTrap™ is a simple and effective solution to remove sediment and trash from stormwater systems at its source. The LittaTrap sits inside the storm drain and captures and retains sediment and trash before it enters stormwater infrastructure, effectively pretreating downstream structures and aiding in pollutant removal.

LEARN MORE

- Access project profiles, photos, videos, and more online at www.imbriumsystems.com/stormceptoref.

REQUEST DESIGN ASSISTANCE

- Call us at (888) 279-8826 or 301-279-8827 to talk to one of our engineers for technical support or design assistance.

START A PROJECT

- Submit your system requirements on our product Design Worksheet at www.imbriumsystems.com/pdw.

FIND A LOCAL REPRESENTATIVE

- Visit www.imbrumsystems.com/localrep for contact information for your local Imbrium representative.



© 2019 Imbrium Systems Inc.

+1 416-960-9900

www.imbriumsystems.com

All Rights Reserved. Printed in the USA.

Imbrium® Systems is an engineered stormwater treatment company that designs and manufactures stormwater treatment solutions that protect water resources from harmful pollutants. By developing technologies to address the long-term impact of urban runoff, Imbrium ensures our clients' projects are compliant with government water quality regulations. For information, visit www.imbriumsystems.com or call +1 416-960-9900.

Get Social With Us!



IB-Stormceptor EF Bro 5/19 PDF

NOTHING IN THIS CATALOG SHOULD BE CONSTRUED AS AN EXPRESSED WARRANTY OR AN IMPLIED WARRANTY OF MERCHANTABILITY OR FITNESS FOR ANY PARTICULAR PURPOSE. SEE THE IMBRIUM STANDARD CONDITIONS OF SALE (VIEWABLE AT WWW.IMBRIUMSYSTEMS.COM/TERMS-OF-USE) FOR MORE INFORMATION.



Stormceptor® EF Sizing Report

Imbrium® Systems

ESTIMATED NET ANNUAL SEDIMENT (TSS) LOAD REDUCTION

05/29/2025

Province:	Ontario
City:	Ottawa
Nearest Rainfall Station:	OTTAWA CDA RCS
Climate Station Id:	6105978
Years of Rainfall Data:	20

Project Name:	1015 Tweddle
Project Number:	67908
Designer Name:	amr salem
Designer Company:	exp
Designer Email:	amr.salem@exp.com
Designer Phone:	613-688-1899
EOR Name:	
EOR Company:	
EOR Email:	
EOR Phone:	

Site Name:	1015 Tweddle Road
------------	-------------------

Drainage Area (ha):	1.05
---------------------	------

Runoff Coefficient 'c':	0.85
-------------------------	------

Particle Size Distribution:	Fine
-----------------------------	------

Target TSS Removal (%):	80.0
-------------------------	------

Required Water Quality Runoff Volume Capture (%):	90.00
Estimated Water Quality Flow Rate (L/s):	28.81
Oil / Fuel Spill Risk Site?	No
Upstream Flow Control?	No
Peak Conveyance (maximum) Flow Rate (L/s):	
Influent TSS Concentration (mg/L):	200
Estimated Average Annual Sediment Load (kg/yr):	1087
Estimated Average Annual Sediment Volume (L/yr):	884

Net Annual Sediment (TSS) Load Reduction Sizing Summary	
Stormceptor Model	TSS Removal Provided (%)
EF4	78
EF5	83
EF6	87
EF8	92
EF10	95
EF12	97

Recommended Stormceptor EF Model: EF5
Estimated Net Annual Sediment (TSS) Load Reduction (%): 83
Water Quality Runoff Volume Capture (%): > 90



THIRD-PARTY TESTING AND VERIFICATION

► **Stormceptor® EF and Stormceptor® EFO** are the latest evolutions in the Stormceptor® oil-grit separator (OGS) technology series, and are designed to remove a wide variety of pollutants from stormwater and snowmelt runoff. These technologies have been third-party tested in accordance with the Canadian ETV **Procedure for Laboratory Testing of Oil-Grit Separators** and performance has been third-party verified in accordance with the **ISO 14034 Environmental Technology Verification (ETV)** protocol.

PERFORMANCE

► **Stormceptor® EF and EFO** remove stormwater pollutants through gravity separation and floatation, and feature a patent-pending design that generates positive removal of total suspended solids (TSS) throughout each storm event, including high-intensity storms. Captured pollutants include sediment, free oils, and sediment-bound pollutants such as nutrients, heavy metals, and petroleum hydrocarbons. Stormceptor is sized to remove a high level of TSS from the frequent rainfall events that contribute the vast majority of annual runoff volume and pollutant load. The technology incorporates an internal bypass to convey excessive stormwater flows from high-intensity storms through the device without resuspension and washout (scour) of previously captured pollutants. Proper routine maintenance ensures high pollutant removal performance and protection of downstream waterways.

PARTICLE SIZE DISTRIBUTION (PSD)

► The **Canadian ETV PSD** shown in the table below was used, or in part, for this sizing. This is the identical PSD that is referenced in the Canadian ETV **Procedure for Laboratory Testing of Oil-Grit Separators** for both sediment removal testing and scour testing. The Canadian ETV PSD contains a wide range of particle sizes in the sand and silt fractions, and is considered reasonably representative of the particle size fractions found in typical urban stormwater runoff.

Particle Size (µm)	Percent Less Than	Particle Size Fraction (µm)	Percent
1000	100	500-1000	5
500	95	250-500	5
250	90	150-250	15
150	75	100-150	15
100	60	75-100	10
75	50	50-75	5
50	45	20-50	10
20	35	8-20	15
8	20	5-8	10
5	10	2-5	5
2	5	<2	5

Stormceptor® EF Sizing Report

Rainfall Intensity (mm / hr)	Percent Rainfall Volume (%)	Cumulative Rainfall Volume (%)	Flow Rate (L/s)	Flow Rate (L/min)	Surface Loading Rate (L/min/m ²)	Removal Efficiency (%)	Incremental Removal (%)	Cumulative Removal (%)
0.50	8.6	8.6	1.24	74.0	41.0	100	8.6	8.6
1.00	20.3	29.0	2.48	149.0	82.0	98	20.0	28.6
2.00	16.2	45.2	4.96	298.0	164.0	88	14.3	43.0
3.00	12.0	57.2	7.44	447.0	245.0	81	9.7	52.7
4.00	8.4	65.6	9.92	595.0	327.0	78	6.5	59.2
5.00	5.9	71.6	12.41	744.0	409.0	74	4.4	63.6
6.00	4.6	76.2	14.89	893.0	491.0	72	3.4	67.0
7.00	3.1	79.3	17.37	1042.0	573.0	71	2.2	69.2
8.00	2.7	82.0	19.85	1191.0	654.0	70	1.9	71.1
9.00	3.3	85.3	22.33	1340.0	736.0	70	2.3	73.4
10.00	2.3	87.6	24.81	1489.0	818.0	69	1.6	75.0
11.00	1.6	89.2	27.29	1638.0	900.0	68	1.1	76.1
12.00	1.3	90.5	29.77	1786.0	982.0	68	0.9	77.0
13.00	1.7	92.2	32.25	1935.0	1063.0	69	1.2	78.2
14.00	1.2	93.5	34.74	2084.0	1145.0	70	0.9	79.0
15.00	1.2	94.6	37.22	2233.0	1227.0	72	0.8	79.9
16.00	0.7	95.3	39.70	2382.0	1309.0	73	0.5	80.4
17.00	0.7	96.1	42.18	2531.0	1391.0	75	0.6	80.9
18.00	0.4	96.5	44.66	2680.0	1472.0	72	0.3	81.2
19.00	0.4	96.9	47.14	2829.0	1554.0	68	0.3	81.5
20.00	0.2	97.1	49.62	2977.0	1636.0	65	0.1	81.6
21.00	0.5	97.5	52.10	3126.0	1718.0	62	0.3	81.9
22.00	0.2	97.8	54.59	3275.0	1800.0	59	0.1	82.1
23.00	1.0	98.8	57.07	3424.0	1881.0	56	0.6	82.6
24.00	0.3	99.1	59.55	3573.0	1963.0	54	0.1	82.8
25.00	0.0	99.1	62.03	3722.0	2045.0	52	0.0	82.8
30.00	0.9	100.0	74.43	4466.0	2454.0	43	0.4	83.2
35.00	0.0	100.0	86.84	5210.0	2863.0	38	0.0	83.2
40.00	0.0	100.0	99.25	5955.0	3272.0	33	0.0	83.2
45.00	0.0	100.0	111.65	6699.0	3681.0	29	0.0	83.2
Estimated Net Annual Sediment (TSS) Load Reduction =								83 %

Climate Station ID: 6105978 Years of Rainfall Data: 20

RAINFALL DATA FROM OTTAWA CDA RCS RAINFALL STATION

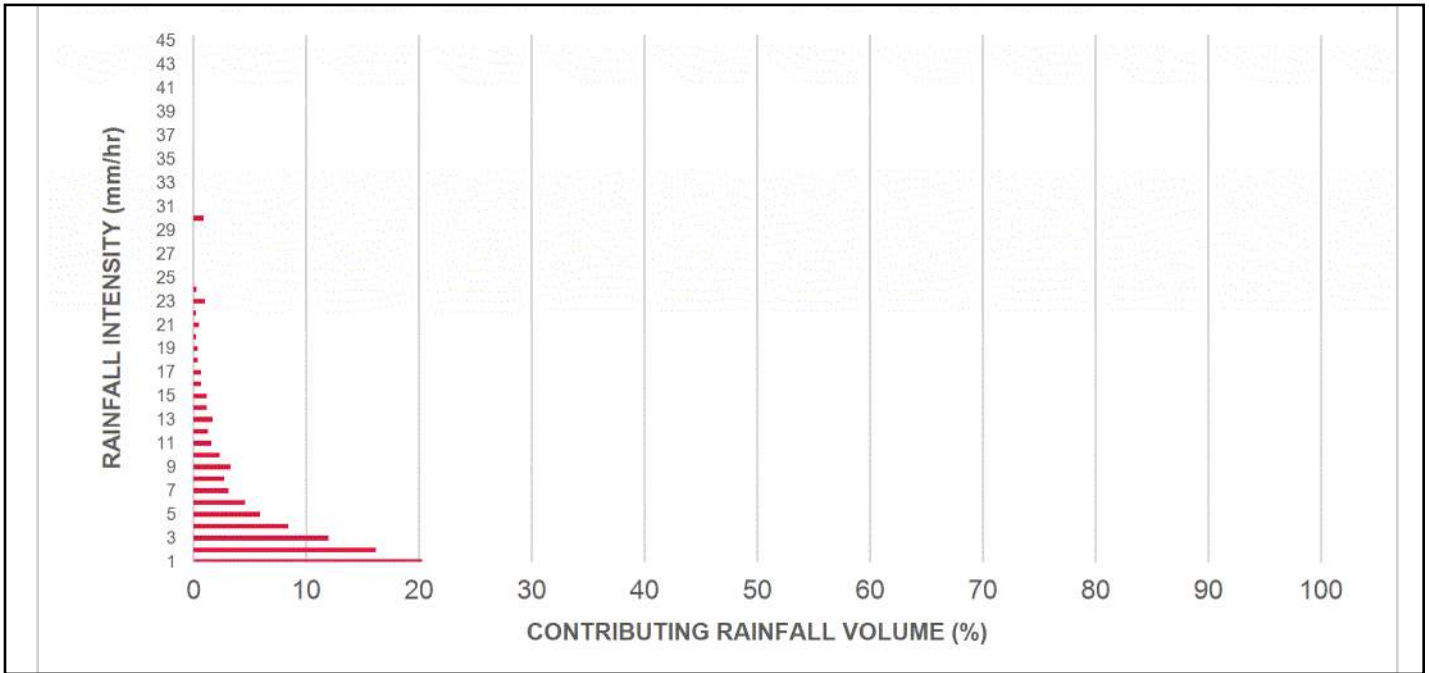

INCREMENTAL AND CUMULATIVE TSS REMOVAL FOR THE RECOMMENDED STORMCEPTOR[®] MODEL

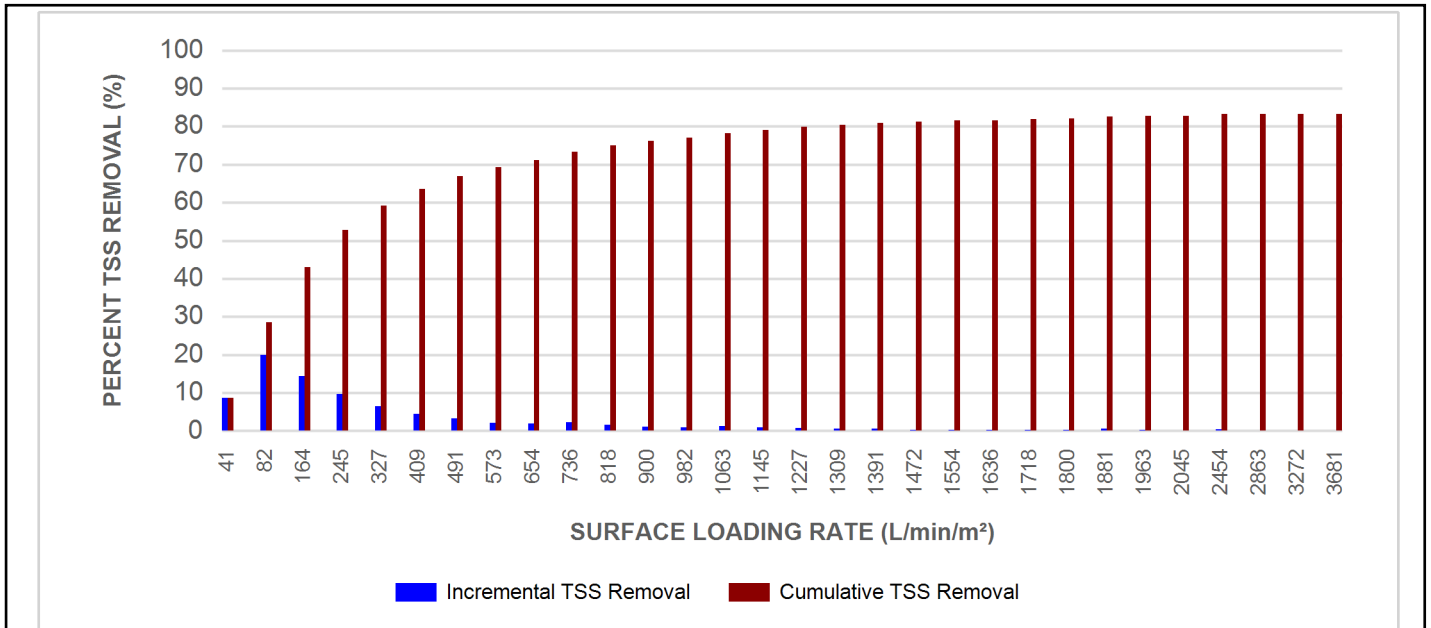

Stormceptor® EF Sizing Report

Maximum Pipe Diameter / Peak Conveyance

Stormceptor EF / EFO	Model Diameter		Min Angle Inlet / Outlet Pipes	Max Inlet Pipe Diameter		Max Outlet Pipe Diameter		Peak Conveyance Flow Rate	
	(m)	(ft)		(mm)	(in)	(mm)	(in)	(L/s)	(cfs)
EF4 / EFO4	1.2	4	90	609	24	609	24	425	15
EF5 / EFO5	1.5	5	90	762	30	762	30	710	25
EF6 / EFO6	1.8	6	90	914	36	914	36	990	35
EF8 / EFO8	2.4	8	90	1219	48	1219	48	1700	60
EF10 / EFO10	3.0	10	90	1828	72	1828	72	2830	100
EF12 / EFO12	3.6	12	90	1828	72	1828	72	2830	100

SCOUR PREVENTION AND ONLINE CONFIGURATION

► Stormceptor® EF and EFO feature an internal bypass and superior scour prevention technology that have been demonstrated in third-party testing according to the scour testing provisions of the Canadian ETV **Procedure for Laboratory Testing of Oil-Grit Separators**, and the exceptional scour test performance has been third-party verified in accordance with the ISO 14034 ETV protocol. As a result, Stormceptor EF and EFO are approved for online installation, eliminating the need for costly additional bypass structures, piping, and installation expense.

DESIGN FLEXIBILITY

► Stormceptor® EF and EFO offers design flexibility in one simplified platform, accepting stormwater flow from a single inlet pipe or multiple inlet pipes, and/or surface runoff through an inlet grate. The device can also serve as a junction structure, accommodate a 90-degree inlet-to-outlet bend angle, and can be modified to ensure performance in submerged conditions.

OIL CAPTURE AND RETENTION

► While Stormceptor® EF will capture and retain oil from dry weather spills and low intensity runoff, Stormceptor® EFO has demonstrated superior oil capture and greater than 99% oil retention in third-party testing according to the light liquid re-entrainment testing provisions of the Canadian ETV **Procedure for Laboratory Testing of Oil-Grit Separators**. Stormceptor EFO is recommended for sites where oil capture and retention is a requirement.

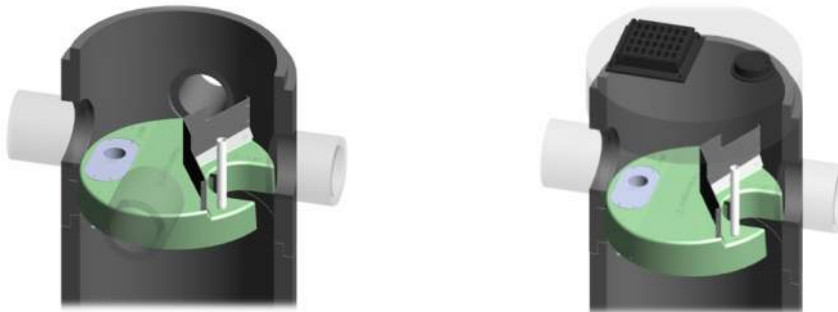

Stormceptor® EF Sizing Report

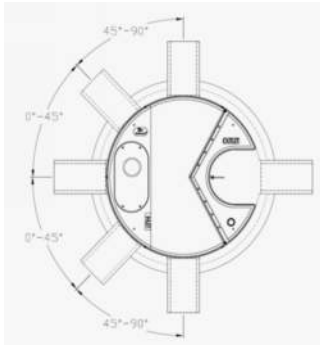

INLET-TO-OUTLET DROP

Elevation differential between inlet and outlet pipe inverts is dictated by the angle at which the inlet pipe(s) enters the unit.

0° - 45° : The inlet pipe is 1-inch (25mm) higher than the outlet pipe.

45° - 90° : The inlet pipe is 2-inches (50mm) higher than the outlet pipe.

HEAD LOSS

The head loss through Stormceptor EF is similar to that of a 60-degree bend structure. The applicable K value for calculating minor losses through the unit is 1.1. For submerged conditions the applicable K value is 3.0.

Pollutant Capacity

Stormceptor EF / EFO	Model Diameter		Depth (Outlet Pipe Invert to Sump Floor)		Oil Volume		Recommended Sediment Maintenance Depth *		Maximum Sediment Volume *		Maximum Sediment Mass **	
	(m)	(ft)	(m)	(ft)	(L)	(Gal)	(mm)	(in)	(L)	(ft³)	(kg)	(lb)
EF4 / EFO4	1.2	4	1.52	5.0	265	70	203	8	1190	42	1904	5250
EF5 / EFO5	1.5	5	1.62	5.3	420	111	305	10	2124	75	2612	5758
EF6 / EFO6	1.8	6	1.93	6.3	610	160	305	12	3470	123	5552	15375
EF8 / EFO8	2.4	8	2.59	8.5	1070	280	610	24	8780	310	14048	38750
EF10 / EFO10	3.0	10	3.25	10.7	1670	440	610	24	17790	628	28464	78500
EF12 / EFO12	3.6	12	3.89	12.8	2475	655	610	24	31220	1103	49952	137875

*Increased sump depth may be added to increase sediment storage capacity

** Average density of wet packed sediment in sump = 1.6 kg/L (100 lb/ft³)

Feature	Benefit	Feature Appeals To
Patent-pending enhanced flow treatment and scour prevention technology	Superior, verified third-party performance	Regulator, Specifying & Design Engineer
Third-party verified light liquid capture and retention for EFO version	Proven performance for fuel/oil hotspot locations	Regulator, Specifying & Design Engineer, Site Owner
Functions as bend, junction or inlet structure	Design flexibility	Specifying & Design Engineer
Minimal drop between inlet and outlet	Site installation ease	Contractor
Large diameter outlet riser for inspection and maintenance	Easy maintenance access from grade	Maintenance Contractor & Site Owner

STANDARD STORMCEPTOR EF/EFO DRAWINGS

For standard details, please visit <http://www.imbriumsystems.com/stormwater-treatment-solutions/stormceptor-ef>

STANDARD STORMCEPTOR EF/EFO SPECIFICATION

For specifications, please visit <http://www.imbriumsystems.com/stormwater-treatment-solutions/stormceptor-ef>

STANDARD PERFORMANCE SPECIFICATION FOR “OIL GRIT SEPARATOR” (OGS) STORMWATER QUALITY TREATMENT DEVICE

PART 1 – GENERAL

1.1 WORK INCLUDED

This section specifies requirements for selecting, sizing, and designing an underground Oil Grit Separator (OGS) device for stormwater quality treatment, with third-party testing results and a Statement of Verification in accordance with ISO 14034 Environmental Management – Environmental Technology Verification (ETV).

1.2 REFERENCE STANDARDS & PROCEDURES

ISO 14034:2016 Environmental management – Environmental technology verification (ETV)

Canadian Environmental Technology Verification (ETV) Program’s **Procedure for Laboratory Testing of Oil-Grit Separators.**

1.3 SUBMITTALS

1.3.1 All submittals, including sizing reports & shop drawings, shall be submitted upon request with each order to the contractor then forwarded to the Engineer of Record for review and acceptance. Shop drawings shall detail all OGS components, elevations, and sequence of construction.

1.3.2 Alternative devices shall have features identical to or greater than the specified device, including: treatment chamber diameter, treatment chamber wet volume, sediment storage volume, and oil storage volume.

1.3.3 Unless directed otherwise by the Engineer of Record, OGS stormwater quality treatment product substitutions or alternatives submitted within ten days prior to project bid shall not be accepted. All alternatives or substitutions submitted shall be signed and sealed by a local registered Professional Engineer, based on the exact same criteria detailed in Section 3, in entirety, subject to review and approval by the Engineer of Record.

PART 2 – PRODUCTS

2.1 OGS POLLUTANT STORAGE

The OGS device shall include a sump for sediment storage, and a protected volume for the capture and storage of petroleum hydrocarbons and buoyant gross pollutants. The **minimum** sediment & petroleum hydrocarbon storage capacity shall be as follows:

2.1.1	4 ft (1219 mm) Diameter OGS Units:	1.19 m ³ sediment / 265 L oil
	5 ft (1524 mm) Diameter OGS Units:	1.95 m ³ sediment / 420L oil
	6 ft (1829 mm) Diameter OGS Units:	3.48 m ³ sediment / 609 L oil
	8 ft (2438 mm) Diameter OGS Units:	8.78 m ³ sediment / 1,071 L oil
	10 ft (3048 mm) Diameter OGS Units:	17.78 m ³ sediment / 1,673 L oil
	12 ft (3657 mm) Diameter OGS Units:	31.23 m ³ sediment / 2,476 L oil

PART 3 – PERFORMANCE & DESIGN

3.1 GENERAL

The OGS stormwater quality treatment device shall be verified in accordance with ISO 14034:2016 Environmental management – Environmental technology verification (ETV). The OGS stormwater quality treatment device shall remove oil, sediment and gross pollutants from stormwater runoff during frequent wet weather events, and retain these pollutants during less frequent high flow wet weather events below the insert within the OGS for later removal during maintenance. The Manufacturer shall have at least ten (10) years of local experience, history and success in engineering design, manufacturing and production and supply of OGS stormwater quality treatment device systems, acceptable to the Engineer of Record.

3.2 SIZING METHODOLOGY

The OGS device shall be engineered, designed and sized to provide stormwater quality treatment based on treating a minimum of 90 percent of the average annual runoff volume and a minimum removal of an annual average 60% of the sediment (TSS) load based on the Particle Size Distribution (PSD) specified in the sizing report for the specified device. Sizing of the OGS shall be determined by use of a minimum ten (10) years of local historical rainfall data provided by Environment Canada. Sizing shall also be determined by use of the sediment removal performance data derived from the ISO 14034 ETV third-party verified laboratory testing data from testing conducted in accordance with the Canadian ETV protocol Procedure for Laboratory Testing of Oil-Grit Separators, as follows:

3.2.1 Sediment removal efficiency for a given surface loading rate and its associated flow rate shall be based on sediment removal efficiency demonstrated at the seven (7) tested surface loading rates specified in the protocol, ranging 40 L/min/m² to 1400 L/min/m², and as stated in the ISO 14034 ETV Verification Statement for the OGS device.

3.2.2 Sediment removal efficiency for surface loading rates between 40 L/min/m² and 1400 L/min/m² shall be based on linear interpolation of data between consecutive tested surface loading rates.

3.2.3 Sediment removal efficiency for surface loading rates less than the lowest tested surface loading rate of 40 L/min/m² shall be assumed to be identical to the sediment removal efficiency at 40 L/min/m². No extrapolation shall be allowed that results in a sediment removal efficiency that is greater than that demonstrated at 40 L/min/m².

3.2.4 Sediment removal efficiency for surface loading rates greater than the highest tested surface loading rate of 1400 L/min/m² shall assume zero sediment removal for the portion of flow that exceeds 1400 L/min/m², and shall be calculated using a simple proportioning formula, with 1400 L/min/m² in the numerator and the higher surface loading rate in the denominator, and multiplying the resulting fraction times the sediment removal efficiency at 1400 L/min/m².

The OGS device shall also have sufficient annual sediment storage capacity as specified and calculated in Section 2.1.

3.3 CANADIAN ETV or ISO 14034 ETV VERIFICATION OF SCOUR TESTING

The OGS device shall have Canadian ETV or ISO 14034 ETV Verification of third-party scour testing conducted in accordance with the Canadian ETV Program's **Procedure for Laboratory Testing of Oil-Grit Separators**.

3.3.1 To be acceptable for on-line installation, the OGS device must demonstrate an average scour test effluent concentration less than 10 mg/L at each surface loading rate tested, up to and including 2600 L/min/m².

Appendix D – Consultation / Correspondence

City of Ottawa Water System Boundary Conditions

Boundary Conditions 1009 Trim Road

Provided Information

Scenario	Demand	
	L/min	L/s
Average Daily Demand	342	5.70
Maximum Daily Demand	852	14.20
Peak Hour	1,866	31.10
Fire Flow Demand #1	6,000	100.00
Fire Flow Demand #2	10,020	167.00

Location



Results

Connection 1 – Jeanne D'Arc Blvd.

Demand Scenario	Head (m)	Pressure ¹ (psi)
Maximum HGL	113.6	88.5
Peak Hour	106.7	78.6
Max Day plus Fire 1	112.0	86.2
Max Day plus Fire 2	102.9	73.3

¹ Ground Elevation = 51.4 m

Connection 2 – Jeanne D’Arc Blvd.

Demand Scenario	Head (m)	Pressure ¹ (psi)
Maximum HGL	113.6	89.2
Peak Hour	106.7	79.3
Max Day plus Fire 1	107.7	80.7
Max Day plus Fire 2	102.9	74.0

¹ Ground Elevation = 50.9 m

Notes

1. A second connection to the watermain is required to decrease vulnerability of the water system in case of breaks.
2. As per the Ontario Building Code in areas that may be occupied, the static pressure at any fixture shall not exceed 552 kPa (80 psi.) Pressure control measures to be considered are as follows, in order of preference:
 - a. If possible, systems to be designed to residual pressures of 345 to 552 kPa (50 to 80 psi) in all occupied areas outside of the public right-of-way without special pressure control equipment.
 - b. Pressure reducing valves to be installed immediately downstream of the isolation valve in the home/ building, located downstream of the meter so it is owner maintained.

Disclaimer

The boundary condition information is based on current operation of the city water distribution system. The computer model simulation is based on the best information available at the time. The operation of the water distribution system can change on a regular basis, resulting in a variation in boundary conditions. The physical properties of watermains deteriorate over time, as such must be assumed in the absence of actual field test data. The variation in physical watermain properties can therefore alter the results of the computer model simulation. Fire Flow analysis is a reflection of available flow in the watermain; there may be additional restrictions that occur between the watermain and the hydrant that the model cannot take into account.



August 1, 2024

Thomas Freeman
Fotenn Planning + Design
Via email: freeman@fotenn.com

Subject: Pre-Consultation Meeting Feedback
Proposed Site Plan Control Application – 1015 Tweddle Road

Please find below information regarding next steps as well as consolidated comments from the above-noted pre-consultation meeting held on July 17, 2024.

1. Pre-Consultation Preliminary Assessment

1 <input type="checkbox"/>	2 <input type="checkbox"/>	3 <input checked="" type="checkbox"/>	4 <input type="checkbox"/>	5 <input type="checkbox"/>
----------------------------	----------------------------	---------------------------------------	----------------------------	----------------------------

One (1) indicates that considerable major revisions are required while five (5) suggests that the proposal appears to meet the City’s key land use policies and guidelines. This assessment is purely advisory and does not consider technical aspects of the proposal or in any way guarantee application approval.

2. Next Steps

1. Thank you for meeting with staff for a pre-application consultation regarding proposed development on this site. We are committed to working with you to flush out concerns and address them before the design and applications proceed.
2. Staff reiterate that a concept plan would benefit from continuing to remain in the Pre-Consultation phase in order to address the comments and issues raised at the meeting and specified in this letter. We will continue to process this under the existing Pre-Consultation application. Please continue to reference the PC2024-0280 in future correspondence.
3. Please find attached all comments or issues detailed herein by staff and ensure that they are addressed. A detailed cover letter stating how each issue has been addressed must be included with the submission materials. Please coordinate the numbering of your responses within the cover letter with the comment number(s) herein and submit it together with the necessary studies and/or plans to planningcirculations@ottawa.ca.
4. If your development proposal changes significantly in scope, design, or density before the next submission, you may need to revisit previous comments.



3. Supporting Information and Material Requirements

1. The attached **Study and Plan Identification List** outlines the information and material that has been identified, during this phase of pre-consultation, as either required (R) or advised (A) as part of a future complete application submission.
 - a. The required plans and studies must meet the City's Terms of Reference (ToR) and/or Guidelines, as available on Ottawa.ca. These ToR and Guidelines outline the specific requirements that must be met for each plan or study to be deemed adequate.

4. Consultation with Technical Agencies

1. You are encouraged to consult with technical agencies early in the development process and throughout the development of your project concept. A list of technical agencies and their contact information is enclosed.

5. Planning

Comments:

1. Official Plan – Neighbourhood, Evolving Neighbourhood Overlay
2. The property is within the Orleans Corridor Secondary Plan and is designated as Station Core. Please have extra consideration for the following CDP Policies:
 - a. Section 4.6 - High-rise Policies
 - b. Section 4.10 - Parks and Privately-Owned Publicly Accessible Spaces Policies
 - c. Section 4.15 – Natural Hazard – Sensitive Marine Clay / Leda Clay
 - d. Section 5.1 – Station Core
 - e. Section 6.5 – Trim Station Area
 - i. 6.5.4
 - ii. 6.5.8
 - iii. 6.5.15-18
3. Lifting of the Holding Zone is required before any development may proceed on the site.
4. Community Benefits Charge
 - a. The former Section 37 regime has been replaced with a “Community Benefits Charge”, [By-law No. 2022-307](#), of 4% of the land value. This



charge will be required for ALL buildings that are 5 or more storeys and 10 or more units and will be required at the time of building permit unless the development is subject to an existing registered Section 37 agreement.

Questions regarding this change can be directed to

Ranbir.Singh@ottawa.ca.

5. Please refer to the City's Urban Design Guidelines for High Rise Buildings.
6. The parking garage entrance off Tweddle Road is in close proximity to the flood plain. Grading and street improvement will be necessary to maintain the proposed location.
7. The parking garage entrance off Jeanne d'Arc Boulevard should be further east in B4 to allow the commercial units in the shared podium of towers B2 and B3 to have an uninterrupted facade.
8. Revise all plans to reflect new property boundary based on acquisition of City lands at the intersection of Tweddle Road and Jeanne d'Arc Boulevard.
9. Planning staff are willing to work with other City staff and the RVCA to investigate the potential locations of formal paths and lookouts to take advantage of the site's location.
10. Landscaping and soil volumes over the parking garage is a concern—will the vegetation and plantings shown on the concept plan be feasible with the proposed soil volumes?
11. Provide more detail about how the areas between the buildings and towards the water will be programmed.
12. Lands to the east of the site are protected and there needs to be more sensitivity with respect to maintaining shared trees and protecting that edge.
13. Pedestrian Easements and Maintenance and Liability Agreements may be required depending on the approval and design.
14. Staff confirmed with the Light Rail Office that this site falls outside of the LRT Development Zone of Influence. An O-Train Proximity Study will not be required for any subsequent Site Plan Control application.
15. The building design needs to be sensitive to existing overhead wires, or burial/ relocation should be considered to improve the public realm.

Please contact Steve Belan, File Lead, for any questions related to Planning comments.

6. Urban Design

Comments:



16. An Urban Design Brief is required. Please see attached customized Terms of Reference to guide the preparation. Here are a few highlights:
 - a. The Urban Design Brief should be structured by generally following the headings highlighted under Section 3 – Contents of these Terms of Reference.
 - b. Please document design evolutions.
 - c. Please document and show natural heritage and assets on the site and in the area.
 - d. It is crucially important to provide very detailed plans and section drawings to illustrate the approach to public realm and the grading relationship between the building ground floors and the abutting public realm.
 - e. The Urban Design Brief will also serve as the submission to the Urban Design Review Panel (UDRP) (see notes below).
17. The site is not in a Design Priority Area; however, per Zoning By-Law Exception 2834, the Site Plan Control application is subject to UDRP review.
18. UDRP review will occur at the pre-consultation stage. Please contact udrp@ottawa.ca for scheduling details. To ensure productivity, it is recommended that the applicant confirm ownership of the entirety of the lands subject to this Site Plan Control application with the City, including lands currently owned by the City, develop the design a little bit further, including the design of the parking garage and the public realm, before submitting a request for UDRP review.
19. The submission of a UDRP report is a requirement for deeming the Site Plan Control application complete. The Terms of Reference of the UDRP report can be found [here](#).
20. Additional drawings and studies are required as indicated in the attached Urban Design Brief and outlines in the Study and Plan Identification List (SPIL). These additional drawings and studies must be included in the Urban Design Brief since the Urban Design Brief will also serve as the UDRP submission:
 - a. Shadow Study
 - b. Wind Study
 - c. Grading Plan
 - d. Site Servicing Plan
 - e. Landscape Plan



- f. Site Plan
- g. Elevations
- h. Site Cross Sections
- i. Floor Plans

Policy:

21. Please ensure that the design brief addresses:

- a. Design Policies of the Official Plan
- b. Orleans Corridor Secondary Plan
- c. Design Guidelines for High Rise Buildings
- d. Bird Friendly Design Guidelines

Design:

22. The concept has changed significantly from the review during the rezoning application and the previous Site Plan Control pre-consultation. Urban Design has concerns with the revised tower floor plates and interface with Jeanne d'Arc Boulevard.

23. Buildings and podiums should be designed in the round. The waterfront area, Privately-Owned Public Spaces (POPS) and public roads should be considered as public realms.

24. The watercourse trail connection has been removed, please work with environmental planners and Rideau Valley Conservation Area (RVCA) to reinstate this connection.

25. The tower floor plates have significantly increased in size from the rezoning application and must be decreased to 750 square metres. Larger tower floor plates for the exterior towers (B1 and B4) may be considered if tower separations are increased and micro-climate impacts are mitigated.

26. Urban Design has some concern with the interface with Jeanne d'Arc Boulevard, the large setbacks and the tower overhanging podiums have the potential to have impact on the public realm and viability of commercial uses. The street appears to be too wide. Please review building massing and setbacks to ensure that wind/shadow impacts are mitigated and reasonable framing of Jeanne d'Arc Boulevard by the podiums can be achieved. Additionally, the programming of the ground floor should be reviewed in tandem with the landscape scheme of the site to ensure viability of the commercial uses, as now they are quite setback and shadowed.

27. The increased tower floor plates and increased front yard setbacks have moved the towers closer to the waterfront and trail, overpower and pinch the public space. Staff have concern with additional wind and shadow impacts on the open space. Please shift the buildings away from the watercourse and ensure that the microclimate is considered in design and a more open waterfront promenade as envisioned in the Secondary Plan and previous design can be achieved.
28. Urban Design questions the 'cookie cutter' tower form. It may improve placemaking at the corner of Tweddle Road and Jeanne d'Arc Boulevard and improve the interface with the public realms and the tower grouping to vary the tower design.
29. The parking garage entrance on Tweddle Road must be incorporated into the building envelope.
30. Per previous comments, the landscape program for the site will be critical for the development's success. Examine the overall site organization, including building placement and ground floor programming, vehicular and pedestrian circulation, servicing, delineation and/or integration of public spaces and private realm in tandem with the landscaping.
 - a. Please ensure that the design and programming of the site reflects wind and shadow conditions.
 - b. Consider the different uses the POPS will serve.
 - c. Please consider views into the POPS. They must be designed as a public space.
 - d. Tweddle Road and Jeanne d'Arc Boulevard have different contexts. Please consider appropriate interface with these roadways including landscape program, building massing and ground floor uses.
 - e. Consider locations for amenity space and lobbies which can activate the public realm
 - f. On the site plan and landscape plan, please show a realistic design of elements within the right-of-way (ROW), including sidewalks and cycle tracks.
 - g. Please confirm arrangement for loading and garbage collection. It appears that such operations will be internalized and located below grade, which are appropriate. Please also confirm management of these operations including phasing.
 - h. Please identify areas for tree planting.



31. How will the grade change be managed on the site? The ground floors of the proposed development must be leveled with the elevation of the abutting public sidewalk. The ground floors must not be seen and must not function as if it is at a different level. Any grade differences must be carefully managed to ensure a seemly transition between the sidewalk, the exterior space, and the ground floor interior space, and meet the City's accessibility standards. Subject to detailed design and accessibility standards, in general, the maximum grade difference that may be accommodated, should be less than 50-60 centimetres, or 3-4 steps

Please contact Lisa Stern, Urban Designer, for any questions related to Urban Design comments.

7. Engineering

Comments:

Retrogressive Landslide Hazard Risk:

32. There are currently no methodologies at the Provincial level to effectively deal with new developments along slopes where retrogressive landslide hazards might exist. As you may be aware, the City has retained a consultant to assist in consulting with subject matter experts from various fields of practice and jurisdictions, with the goal of deriving interim guidance documents to identify and deal with landslide hazard risk.

Landslides Hazard Risk Assessments had historically been reviewed based on an interim technical guidance document produced by the RVCA for landslide hazard risk assessments. The RVCA's interim guidance is based on an approach from Western Canada (Frasier Valley and Town of Canmore); however, there exist other approaches, including those from Quebec and Norway, among others. The City needs to review all the state-of-the-art approaches and produce City-specific guidance documents. Ultimately, it is the City that is responsible for responding to and addressing landslide hazard risk; therefore, the City must ensure that the approach used to evaluate risk is appropriate.

However, in this specific case, as the retrogressive landslide risk was identified and evaluated comprehensively by the RVCA through the rezoning process in 2022, far before the City initiated the derivation of new guidelines, the City will rely on the RVCA's prior review and approval of retrogressive landslide hazard risk as laid out specifically in the ZBLA holding zone for the site.

Water:

33. Frontage charges apply at \$190/m.
 - a. Location of Accessible Water Main: 406mm PVC municipal watermain on Jeanne d'Arc Boulevard.



- b. Submission documents must include:
 - i. Boundary Conditions - civil consultant to request boundary conditions from the City's assigned Project Manager, Development Review. Water boundary conditions request must include the location of the service and the expected loads required by the proposed development. Please provide all the following information:
 - ii. Location of service (show on a plan or map).
 - iii. Type of development.
 - iv. Average daily demand: ___ l/s.
 - v. Maximum daily demand: ___ l/s.
 - vi. Maximum hourly daily demand: ___ l/s.
 - vii. Required fire flow and completed FUS Design Declaration (if applicable).
 - viii. Supporting Calculations for all demands listed above and required fire flow as per Ontario Building Code or Fire Underwriter Surveys (See technical Bulletin ISTB-2021-03)
- c. Watermain system analysis demonstrating adequate pressure as per Section 4.2.2 of the Water Distribution Guidelines.
- d. Demonstrate adequate hydrant coverage for fire protection. Please review Technical Bulletin ISTB-2018-02, Appendix I Table 1 – maximum flow to be considered from a given hydrant.
- e. Any proposed emergency route (to be satisfactory to Fire Services).
- f. Service areas with a basic demand greater than 50 m³/day shall be connected with a minimum of two water services, separated by an isolation valve, to avoid creation of vulnerable service area.
- g. A District Metering Area Chamber (DMA) is required for services 150mm or greater in diameter.

Sanitary Sewers:

- 34. Location of Accessible Sanitary Sewer: 300mm PVC municipal sanitary sewer on Jeanne d'Arc Boulevard (at capacity).



35. A monitoring maintenance hole shall be required just inside the property line for all non-residential and multi residential building connections from a private sewer to a public sewer. See the Sewer Use By-law for details.
36. Please apply the wastewater design flow parameters in Technical Bulletin PIEDTB-2018-01.
37. For laterals connecting to main with 50% pipe diameter or over, provide a manhole.
38. Provide the proposed peak wet weather sanitary flow rate, along with supporting calculations, to our Asset Management team for analysis to demonstrate that there is adequate residual capacity in the receiving and downstream wastewater system to accommodate the proposed development. This information can be provided in an email to the Project Manager, and we will circulate internally.
39. As discussed in the servicing report for the associated rezoning application, the existing sanitary sewer on Jeanne d'Arc Boulevard will have to be upsized from 300mm to 375mm diameter due to existing capacity constraints. An ECA application to the MECP will be required (municipal infrastructure extension) to accommodate this upsizing.

Storm Sewers:

40. Location of Accessible Storm Sewer: direct outlet to Ottawa River.
41. A monitoring maintenance hole shall be required just inside the property line for all non-residential and multi residential building connections from a private sewer to a public sewer. See the Sewer Use By-law for details.
42. For laterals connecting to main with 50% pipe diameter or over, provide a manhole.

Stormwater Management:

43. Quality Control:

- a. **Suspended Solids:** Provide Enhanced level of protection (80%) for suspended solids removal. Demonstrate ISO 14034 Environmental Technology Verification (ETV) protocol if OGS units are used.
- b. Provide a water balance analysis as per the conservation authority guidelines for development applications. Control the recharge to meet pre-development conditions on subject property.

44. Quantity Control:

- a. None if all stormwater is proposed to discharge to the Ottawa River.



b. Ponding Notes

- i. Permissible ponding of 350mm for the 100-year storm event. No spilling to adjacent sites.
- ii. Beyond the 100-year ponding elevation, all drainage must be spilled to the Right-of-Way.
- iii. 100-year spill elevation must be 300mm lower than any building opening or ramp.
- iv. Demonstrate that the stress test spill elevation (100-year +20% event) does not spill onto any permanent structures.

MECP ECA Requirements:

45. An MECP ECA will be required via ToR if stormwater is proposed to discharge to a watercourse. Note that an ECA could also be required (municipal works) if any shared drainage and/or sanitary servicing is proposed among separate properties.

Additional Notes:

46. No Capital Work Project that would impact the application has been identified at this time.

47. No road moratorium that would impact the application has been identified.

48. Any easement identified should be shown on all plans.

49. For any proposed exterior light fixtures, please provide certification from a licensed professional engineer confirming lighting has been designed only using fixtures that meet the criteria for full cut-off classification as recognized by the Illuminating Engineering Society of North America and result in minimal light spillage onto adjacent properties (maximum allowable spillage is 0.5 fc). Additionally, include in the submission the location of the fixtures, fixture type (make, model, part number and mounting height).

50. Sensitive Marine Clay (SMC) is widely found across Ottawa - geotechnical reports should include Atterberg Limits, consolidation testing, sensitivity values, and vane shear testing.

51. A remediation plan must be detailed and executed as outlined in any recommendations identified in the most recent Phase II ESA conducted for the subject site.



52. No work can be done within the limits of hazard lands as identified in the slope stability analysis for the subject site, including but not limited to walkways, structures, stormwater management units (including OGS), etc.
53. The proposed works must remain outside any identified floodplains, including both the 1:100 year and 1:350 year floodplains as outlined in the Official Plan Section 10.1.3 and in accordance with the RVCA's comments.
54. For ease of reference, please see the following list of required supporting plans and studies required for the infrastructure component of your Site Plan Control Approval application:
 - a. Servicing & Stormwater Management Report, including:
 - i. Demonstrated servicing capacity for all of water, sanitary and storm.
 - ii. Pre-development and post-development drainage area plans for both sanitary and storm.
 - iii. Ponding Plan
 - iv. Modeling as needed.
 - b. Geotechnical Investigation
 - c. Environmental Site Assessment(s)
 - d. Water Budget Assessment
 - e. Grading & Drainage Plan
 - f. Servicing Plan
 - g. Erosion & Sediment Control Plan

Please contact Cam Elsby, Project Manager, for follow-up questions related to Engineering comments.

8. Noise

Comments:

55. Road noise study required.

Please contact Mike Giampa, Transportation Project Manager, for follow-up questions related to Noise comments.



9. Transportation

Comments:

56. Paving the section of Tweddle Road from Jeanne d'Arc Boulevard to the proposed parking garage access is recommended.
57. Right-of-Way (ROW) protection:
 - a. See Schedule C16 of the Official Plan.
 - b. Any requests for exceptions to ROW protection requirements must be discussed with Transportation Planning and concurrence provided by Transportation Planning management.
58. The intersection of Tweddle Road and Jeanne d'Arc Boulevard is a future protected intersection with specific ROW and corner sight triangle requirements. Contact Frank McKinney for more information – frank.mckinney@ottawa.ca
59. An updated TIA submission is required.
60. An RMA submission is required for the new urbanized Jeanne d'Arc Boulevard cross section. This consists of a functional plan, delegated authority approval, detailed design and utility circulation.

Please contact Mike Giampa, Transportation Project Manager, for follow-up questions related to Transportation comments.

10. Environment

Comments:

61. An Environmental Impact Statement (EIS) will be required as part of this application. The triggering features are the presence of Provincially Significant Wetlands (PSW), natural heritage system core areas, and species-at-risk habitat.
62. It is recognized that significant work has already been done on the environmental impacts of this development as part of the previous zoning bylaw adjustment prior to site plan control. However, the previously submitted report is not sufficient for the current site plan application.
63. The previous EIS was primarily focused on establishing the extent of the developable area, the limits of the wetlands, and an appropriate buffer between the two.
64. The new EIS for the site plan stage should focus on how the detailed design of the site, the construction processes, and its long-term use all impact the ecological function of the protected features.



65. New field surveys are required for the new EIS. Previous studies were completed largely in 2020 and are no longer recent enough to be accepted. This includes new species at risk surveys for Blanding's turtles, bats, birds, and butternut and black ash trees, as well as any other species that may be necessary as determined by the consultant.
66. The Phase 1 rehabilitation plan, which began in 2022, established new wetland habitat that formed the edges of the PSW. An update on how this rehabilitation is proceeding should be included in the EIS.
67. The EIS should make mention of stormwater servicing and overland runoff and ensure that no harm is being done to the ecological function of the wetlands or buffer zone as a result.
68. Permanent turtle fencing along the perimeter of the naturalized areas, both adjacent to the development itself and along Tweddle Road, were required as part of the approval of the previous EIS. More detail on this fencing and how it relates with the development perimeter, including any plans for access and how that will be integrated with the fence, is required.
69. Phase 2 of the rehabilitation on site involves tree planting and other naturalization efforts in the buffer space between the development and the wetlands. This plan should be detailed in the EIS.
70. Be aware that as part of a multi-stage rehabilitation plan, as well as compensation for tree removals on the east of the site, the City will be seeking detailed information regarding what ecological functions are present and/or removed, how the rehabilitation plan compensates to an adequate degree in scale and function, and how the selection of tree species plantings facilitates this rehabilitation.
71. The Landscape Plan on its own will not be sufficient. The EIS needs to include an in-depth discussion of which decisions were made and why.
72. Please see the City Forester's comments for additional information.
73. This development will need to adhere closely to the mitigation measures in the City's [Bird Safe Design Guidelines](#). Petrie Island is critical bird habitat; it may be the single most important site across all of Ottawa in that regard. Proper implementation of the BSDG's is absolutely fundamental for this development.
74. As discussed in the pre-consultation meeting, the timing for the construction of the underground parking access ramp should be coordinated so that damage to the landscape of the buffer zone does not occur.

Please contact Mark Elliott, Environmental Planner, for follow-up questions related to Environmental comments.



11. Forestry

Comments:

75. A Tree Conservation Report and Landscape Plan are submission requirements of the Site Plan Control Application. The Tree Conservation Report must be updated to reflect the current plans and site conditions.
76. The EIS must provide guidance in preparing the Landscape Plan. There is a significant woodland east of the property. Prioritizing native species on this site is crucial.
77. The parking garage and associated construction must be designed to accommodate space for new trees and retention of existing trees. The TCR must address mitigation measures for adjacent trees. Removal of an adjacent tree would require permission from the adjacent landowner.
78. The City of Ottawa is working towards a 40% canopy cover target (Section 4.8.2 of the Official Plan). The Landscape Plan must show how this site is contributing to this target. Softscape tree planting must be maximized where feasible. This will likely be around the periphery. Reducing the extent of the parking garage to not extend to the lot line will provide a fantastic tree planting opportunity.

Tree Conservation Report requirements:

79. The following Tree Conservation Report (TCR) requirements have been adapted from the Schedule E of the Urban Tree Protection Guidelines:
 - a. A TCR must be supplied for review along with the suite of other plans/reports required by the City
 - b. Any tree 10 centimetres in diameter or greater and City-owned trees of any diameter require a tree permit issued under the Tree Protection Bylaw; the permit will be based on an approved TCR and made available at or near plan approval.
 - c. The TCR must contain 2 separate plans/maps:
 - i. Plan/Map 1 - show existing conditions with tree cover information.
 - ii. Plan/Map 2 - show proposed development with tree cover information.
 - d. The TCR must list all trees on site, as well as off-site trees if the CRZ (critical root zone) extends into the developed area, by species, diameter, and health condition. Averages can be used if there are forested areas.



- e. Please identify trees by ownership – private onsite, private on adjoining site, city owned, co-owned (trees on a property line)
- f. If trees are to be removed, the TCR must clearly show where they are, and document the reason they cannot be retained.
- g. The removal of trees on a property line will require the permission of both property owners.
- h. All retained trees must be shown, and all retained trees within the area impacted by the development process must be protected as per City guidelines available at Tree Protection Specification or by searching Ottawa.ca
- i. The city encourages the retention of healthy trees; if possible, please seek opportunities for retention of trees that will contribute to the design/function of the site.
- j. Removal of a City tree is not permitted unless justified. If justified, monetary compensation for the value of the tree must be paid before a tree removal permit is issued.

Landscape Plan (LP) requirements:

80. Landscape Plan Terms of Reference must be adhered to for all tree planting.

Additional Elements for Tree Planting in the Right of Way:

81. Please ensure any retained trees are shown on the LP

82. Sensitive Marine Clay - Please follow the City's 2017 Tree Planting in Sensitive Marine Clay guidelines.

83. Soil Volume - Please demonstrate as per the Landscape Plan Terms of Reference that the available soil volumes for new plantings will meet or exceed the minimum soil volumes requested.

84. The city requests that consideration be given to planting native species wherever there is a high probability of survival to maturity.

85. Efforts shall be made to provide as much future canopy cover as possible at a site level, through tree planting and tree retention. The Landscape Plan shall show/document that the proposed tree planting and retention will contribute to the City's overall canopy cover over time. Please provide a projection of the future canopy cover for the site to 40 years

86. Minimum Setbacks



- a. Maintain 1.5 metres from sidewalk or MUP/cycle track or water service laterals.
- b. Maintain 2.5 metres from curb
- c. Coniferous species require a minimum 4.5 metres setback from curb, sidewalk, or MUP/cycle track/pathway.
- d. Maintain 7.5m between large growing trees, and 4m between small growing trees. Park or open space planting should consider 10m spacing, except where otherwise approved in naturalization / afforestation areas.
- e. Adhere to Ottawa Hydro's planting guidelines (species and setbacks) when planting around overhead primary conductors.

87. Tree specifications

- a. Minimum stock size: 50mm tree caliper for deciduous, 200cm height for coniferous.
- b. Maximize the use of large deciduous species wherever possible to maximize future canopy coverage.
- c. Tree planting on city property shall be in accordance with the City of Ottawa's Tree Planting Specification; and if possible, include watering and warranty as described in the specification.
- d. No root barriers, dead-man anchor systems, or planters are permitted.
- e. No tree stakes unless necessary (and only 1 on the prevailing winds side of the tree)

88. Hard surface planting

- a. If there are hard surface plantings, a planting detail must be provided.
- b. Curb style planters are highly recommended.
- c. No grates are to be used and if guards are required, City of Ottawa standard (which can be provided) shall be used.
- d. Trees are to be planted at grade.

Please contact Hayley Murray, Forester, for follow-up questions related to Forestry comments.

12. Parkland

Comments:

89. Cash-in-lieu of parkland / parkland dedication:

- a. Parkland Dedication [By-law No. 2022-280](#)

90. Please confirm the area designated as a POPS. Parks and Facilities Planning did not originally request land conveyance for parkland dedication from this site as it was understood the intent was to provide a POPS with public access to the waterfront on this site. In this regard, the POPS spaces shall demonstrate the following:

- a. Development will incorporate privately-owned public space (POPS), including an area at the intersection of Tweddle Road and Jeanne d'Arc Boulevard oriented towards the river shoreline. Public views to the river will be maintained, and a connection to the multi-use pathway along Jeanne d'Arc Boulevard will be provided.
- b. The granting of surface easements over the areas to be developed as POPS in the R5A[2834] zone in a phased manner that follows the sequence of tower build out to provide for 24 Hour access by the public of the areas developed as POPS.
- c. Publicly accessible space providing views of the Ottawa River through the development, and opportunities to link this public space to Tweddle Road with the intent of creating a gateway for pedestrians and cyclists circulating to and from Petrie Island Park. A pedestrian connection along the waterfront to Tweddle Road is required in this regard.
- d. Please confirm there will be a pedestrian easement over the site to ensure the public can access the site, pathways and waterfront and provide a plan showing the extent of public access. Pedestrian easement for the public though the site should be on an accessible route and free from encumbrances (ie gates / fences).
- e. Previous concept plans demonstrated an "overlook" in addition to pathways. Consider additional public spaces as plans are refined.
- f. To maximize the waterfront experience, please re-consider the location of the parking garage access.
- g. As plans are refined, it is essential to consider how all of the above requires will fit within environmental setback requirements and are located outside of hazard lands and natural heritage features.



91. Parkland dedication will be taken through site plan application. Subject to satisfaction of the above POPS requirement, Parkland dedication will be requested in the form of cash in lieu of parkland. Parkland dedication will be in accordance with the Parkland Dedication By-law at time of application.

Please contact Jessica Button, Parks Planner, for follow-up questions related to Parkland comments.

13. Conservation Authority

Comments:

92. The Landslide Hazard Risk Assessment was accepted by the RVCA's consultant as part of the zoning process, except for the need to update the report regarding group risk.
93. The final update with revisions has been received. BGC will continue as the peer reviewer.

Please contact Eric Lalonde, RVCA, for follow-up questions related to Conservation Authority comments.

14. Other

94. The High Performance Development Standard (HPDS) is a collection of voluntary and required standards that raise the performance of new building projects to achieve sustainable and resilient design and will be applicable to Site Plan Control and Plan of Subdivision applications.
 - a. The HPDS was passed by Council on April 13, 2022, but is not in effect at this time, as Council has referred the 2023 HPDS Update Report back to staff with the direction to bring forward an updated report to Committee at a later date. Please be advised that this is expected to occur in Q3 2024.
 - b. Please refer to the HPDS information at ottawa.ca/HPDS for more information.

15. Submission Requirements and Fees

1. Application for a New Complex Site Plan Control application and the associated fees need to be submitted.

Additional information regarding fees related to planning applications can be found [here](#).

2. The attached **Study and Plan Identification List** outlines the information and material that has been identified as either required (R) or advised (A) as part of a future complete application submission.



The required plans and studies must meet the City's Terms of Reference (ToR) and/or Guidelines, as available on Ottawa.ca. These ToR and Guidelines outline the specific requirements that must be met for each plan or study to be deemed adequate.

3. All of the above comments or issues should be addressed to ensure the effectiveness of the application submission review.

Should there be any questions, please do not hesitate to contact myself or the contact identified for the above areas / disciplines.

Regards,

A handwritten signature in blue ink, appearing to read 'Steve Belan', on a light-colored background.

Steve Belan

- Encl. Study and Plan Identification List
Urban Design Brief
Supplementary Development Information
List of Technical Agencies to Consult
HPDS Example Checklist
HPDS Overview for Applicants
ADS Site Plan Checklist

- c.c. Cass Schlauzero
Kelly Livingstone
Cam Elsby
Kris Haynes
Lisa Stern
Mike Giampa
Mark Elliott
Hayley Murray
Jessica Button
Ranbir Singh
Environmental Remediation Unit
Eric Lalande
Thomas Freeman
Miguel Tremblay

Appendix E – Drawings

Architectural Plans

Plan of Topographic Survey

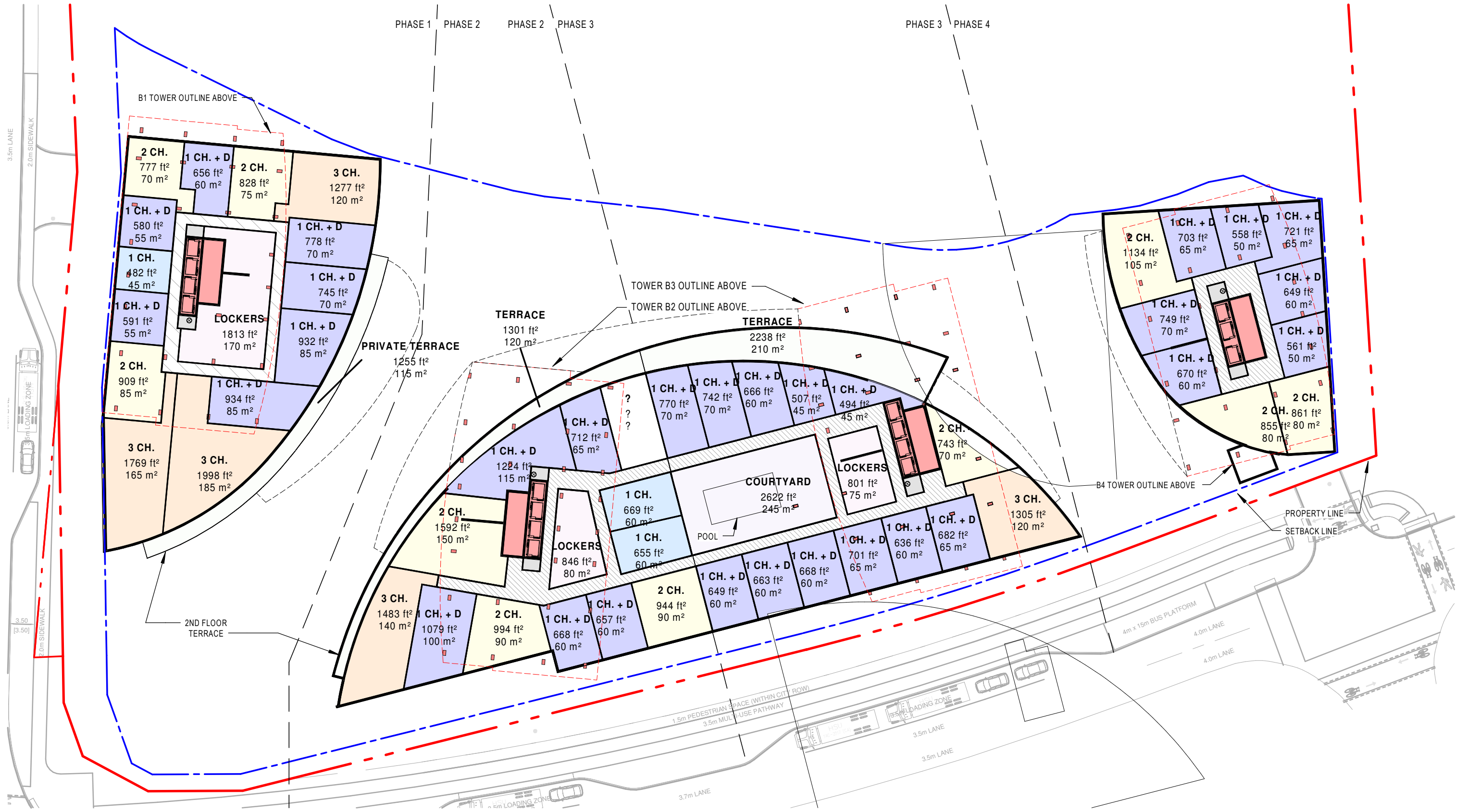

Plan Niveau 2

ÉCHELLE = 1 : 500

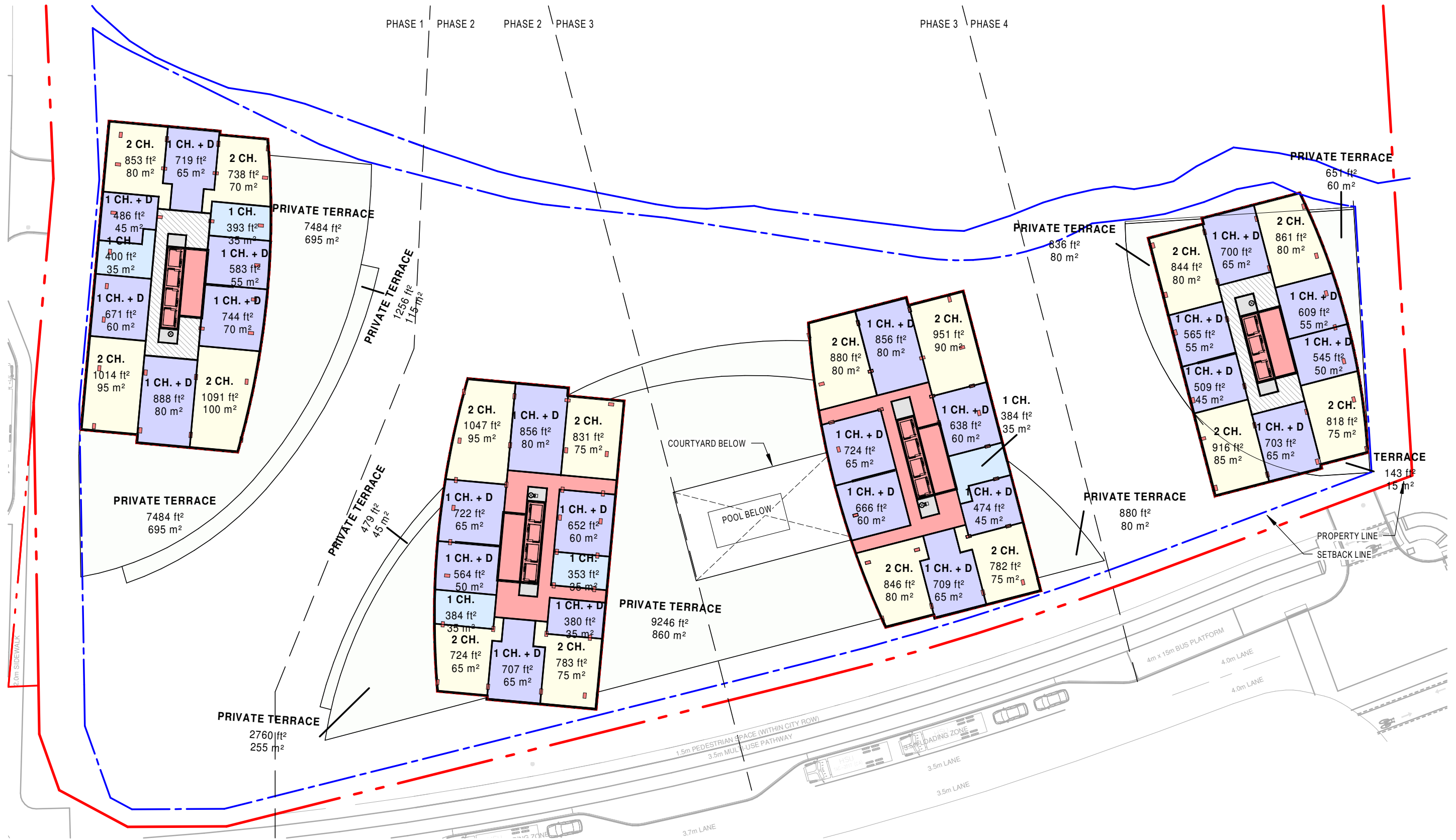

	Aire brute par plancher (construction) / Gross area per floor (construction)		Superficie nette estimée / Estimated Net Area (0.91)		Espaces de stationnement Interieur / Parking spaces	Aire Commerciale / Commercial Area		Aire d'agrément /Amenity Area		Aire non-vendable / Non sellable area		Aire Résidentielle Brute/ Gross Residential Area		Efficiency ratio / Ratio d'efficacité	UNITÉS TOTALES / TOTAL UNITS	UNIT MIX						
	m² / m²	pi² / ft²	m² / m²	pi² / ft²		m² / m²	pi² / ft²	m² / m²	pi² / ft²	m² / m²	pi² / ft²	m² / m²	pi² / ft²			Gross Residential / GFA	studio bachelor	1 chambre 1 bedroom	1 ch + den 1 bed + den	2 chambre 2 bedroom	2 ch + den 2 bed + den	3 chambre 3 bedroom
TOTAL	37278	366806	27845	299718	229	885	9526	607	6529	3953	42552	21953	236304		326	0	53	163	107	0	3	0
ABOVE GRADE	27398	297908	24932	268370	0											0.00%	16.26%	50.00%	32.82%	0.00%	0.92%	0.00%
UNDER GRADE	9601	103346			229																	
PCV	22838	245830			3																	
Ratio		83%			0.70				2.21%		14.43%			0.83								
Mechanical	278	2997																				
28th Floor	928	9989	844	9090		0	0	0	0	131	1410	797	8579	0.86	12	0	2	6	4	0	0	0
27th Floor	928	9989	844	9090		0	0	0	0	131	1410	797	8579	0.86	12	0	2	6	4	0	0	0
26th Floor	928	9989	844	9090		0	0	0	0	131	1410	797	8579	0.86	12	0	2	6	4	0	0	0
25th Floor	928	9989	844	9090		0	0	0	0	131	1410	797	8579	0.86	12	0	2	6	4	0	0	0
24th Floor	928	9989	844	9090		0	0	0	0	131	1410	797	8579	0.86	12	0	2	6	4	0	0	0
23rd Floor	928	9989	844	9090		0	0	0	0	131	1410	797	8579	0.86	12	0	2	6	4	0	0	0
22nd Floor	928	9989	844	9090		0	0	0	0	131	1410	797	8579	0.86	12	0	2	6	4	0	0	0
21st Floor	928	9989	844	9090		0	0	0	0	131	1410	797	8579	0.86	12	0	2	6	4	0	0	0
20th Floor	928	9989	844	9090		0	0	0	0	131	1410	797	8579	0.86	12	0	2	6	4	0	0	0
19th Floor	928	9989	844	9090		0	0	0	0	131	1410	797	8579	0.86	12	0	2	6	4	0	0	0
18th Floor	928	9989	844	9090		0	0	0	0	131	1410	797	8579	0.86	12	0	2	6	4	0	0	0
17th Floor	928	9989	844	9090		0	0	0	0	131	1410	797	8579	0.86	12	0	2	6	4	0	0	0
16th Floor	928	9989	844	9090		0	0	0	0	131	1410	797	8579	0.86	12	0	2	6	4	0	0	0
15th Floor	928	9989	844	9090		0	0	0	0	131	1410	797	8579	0.86	12	0	2	6	4	0	0	0
14th Floor	928	9989	844	9090		0	0	0	0	131	1410	797	8579	0.86	12	0	2	6	4	0	0	0
13th Floor	928	9989	844	9090		0	0	0	0	131	1410	797	8579	0.86	12	0	2	6	4	0	0	0
12th Floor	928	9989	844	9090		0	0	0	0	131	1410	797	8579	0.86	12	0	2	6	4	0	0	0
11th Floor	928	9989	844	9090		0	0	0	0	131	1410	797	8579	0.86	12	0	2	6	4	0	0	0
10th Floor	928	9989	844	9090		0	0	0	0	131	1410	797	8579	0.86	12	0	2	6	4	0	0	0
9th Floor	928	9989	844	9090		0	0	0	0	131	1410	797	8579	0.86	12	0	2	6	4	0	0	0
8th Floor	928	9989	844	9090		0	0	0	0	131	1410	797	8579	0.86	12	0	2	6	4	0	0	0
7th Floor	928	9989	844	9090		0	0	0	0	131	1410	797	8579	0.86	12	0	2	6	4	0	0	0
6th Floor	928	9989	844	9090		0	0	0	0	131	1410	797	8579	0.86	12	0	2	6	4	0	0	0
5th Floor	928	9989	844	9090		0	0	0	0	131	1410	797	8579	0.86	12	0	2	6	4	0	0	0
4th Floor	928	9989	844	9090		0	0	0	0	131	1410	797	8579	0.86	12	0	2	6	4	0	0	0
3rd Floor	928	9989	844	9090		0	0	0	0	131	1409	797	8580	0.86	12	0	2	6	4	0	0	0
2nd Floor (Podium)	1570	16899	1429	15378		0	0	117	1255	222	2391	1231	13254	0.78	14	0	1	7	3	0	3	0
Ground Floor 1	1700	18301	1547	16654		885	9526	490	5274	325	3500	0	0	0.00	0	0	0	0	0	0	0	0
Basement 1	3200	34449	2912	31348	75					42.7												
Basement 2	3200	34449			76					42.1												
Basement 3	3200	34449			78					41.0												

#REF!

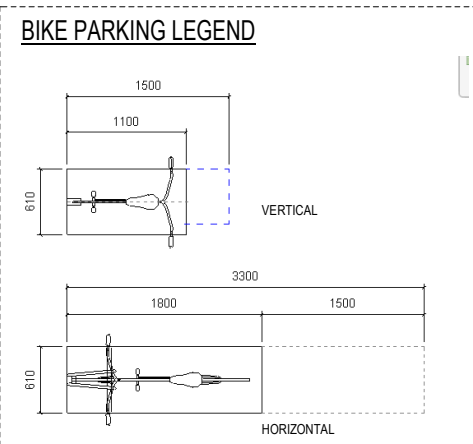
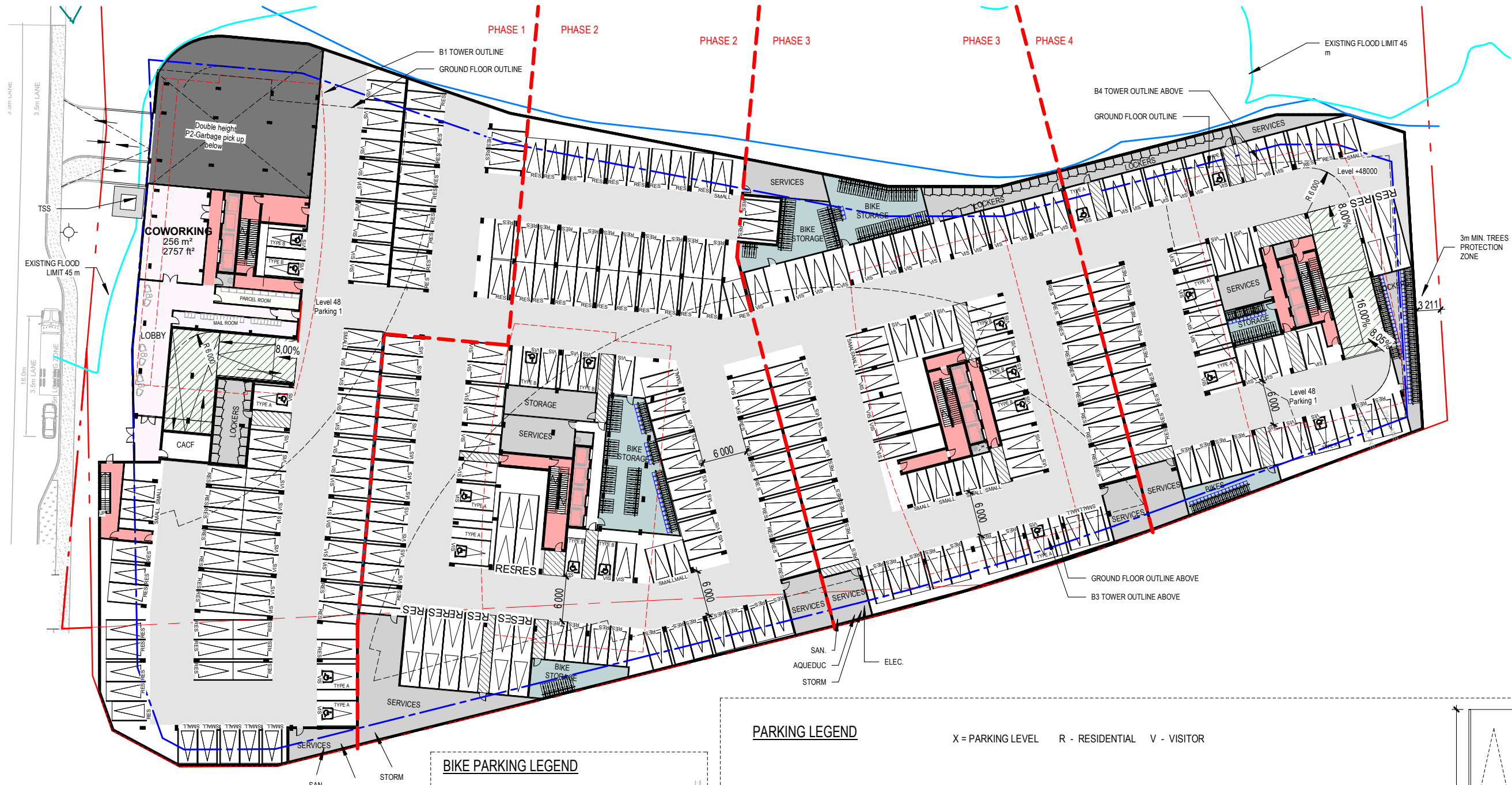

PARKING LEGEND

X = PARKING LEVEL R - RESIDENTIAL V - VISITOR

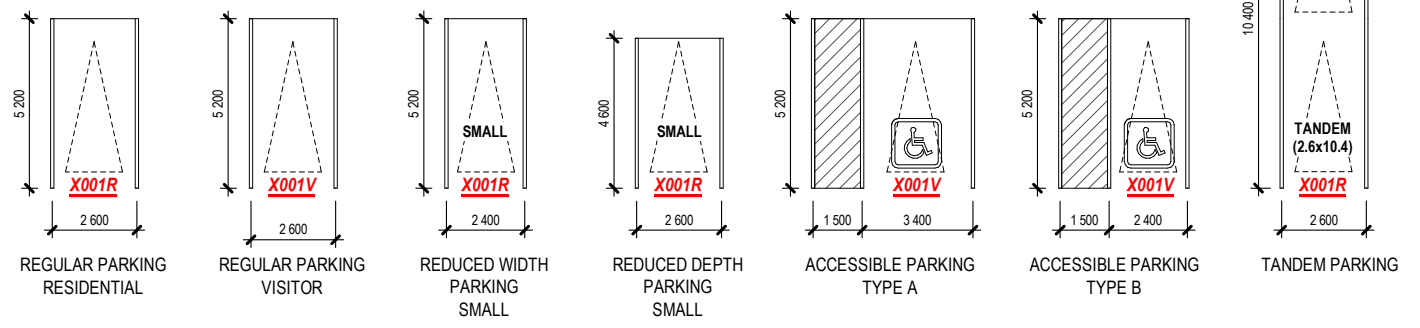

ELEVATIONS

TOWER B2

T.O MECH:
±3.5M

HEIGHT: 102M



HEIGHT: 9.8M



EAST ELEVATION

MATERIALS LEGEND

- (A) Brick
Manufacturer: TBD
Colour: TBD
- (B) Clear Glass
Manufacturer: TBD
- (C) Concrete
Manufacturer: TBD
Colour: TBD

T.O MECH:
±3.5M

HEIGHT: 102M



HEIGHT: 9.8M

WEST ELEVATION

ELEVATIONS

TOWER B2

T.O MECH:
±3.5M

HEIGHT: 102M

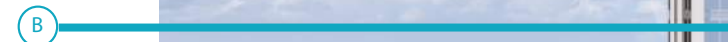

HEIGHT: 9.8M



COMMERCE

NORTH ELEVATION

MATERIALS LEGEND

- (A) Brick
Manufacturer: TBD
Colour: TBD
- (B) Clear Glass
Manufacturer: TBD
- (C) Concrete
Manufacturer: TBD
Colour: TBD

T.O MECH:
±3.5M

HEIGHT: 102M



HEIGHT: 9.8M



SOUTH ELEVATION

Appendix F – PCSWMM Results

PCSWMM Report

Prop_Rev4_SPA_2025_Report
Model Prop_Rev4_SPA_2025.inp

exp Services Inc.

May 30, 2025

Table of Contents

Summaries

Summary 1A: Subcatchment attributes	3
Summary 1B: Subcatchment attributes	5
Summary 2A: Outfall attributes	7
Summary 2B: Outfall attributes	7

Profiles

Figure 1: Node STMMH_200 to Node OUTFALL_2	8
--	---

Tables

Table 1: Subcatchments	9
Table 2: Outfalls	9
Table 3: Junctions	10
Table 4: Storages	10
Table 5: Conduits	10

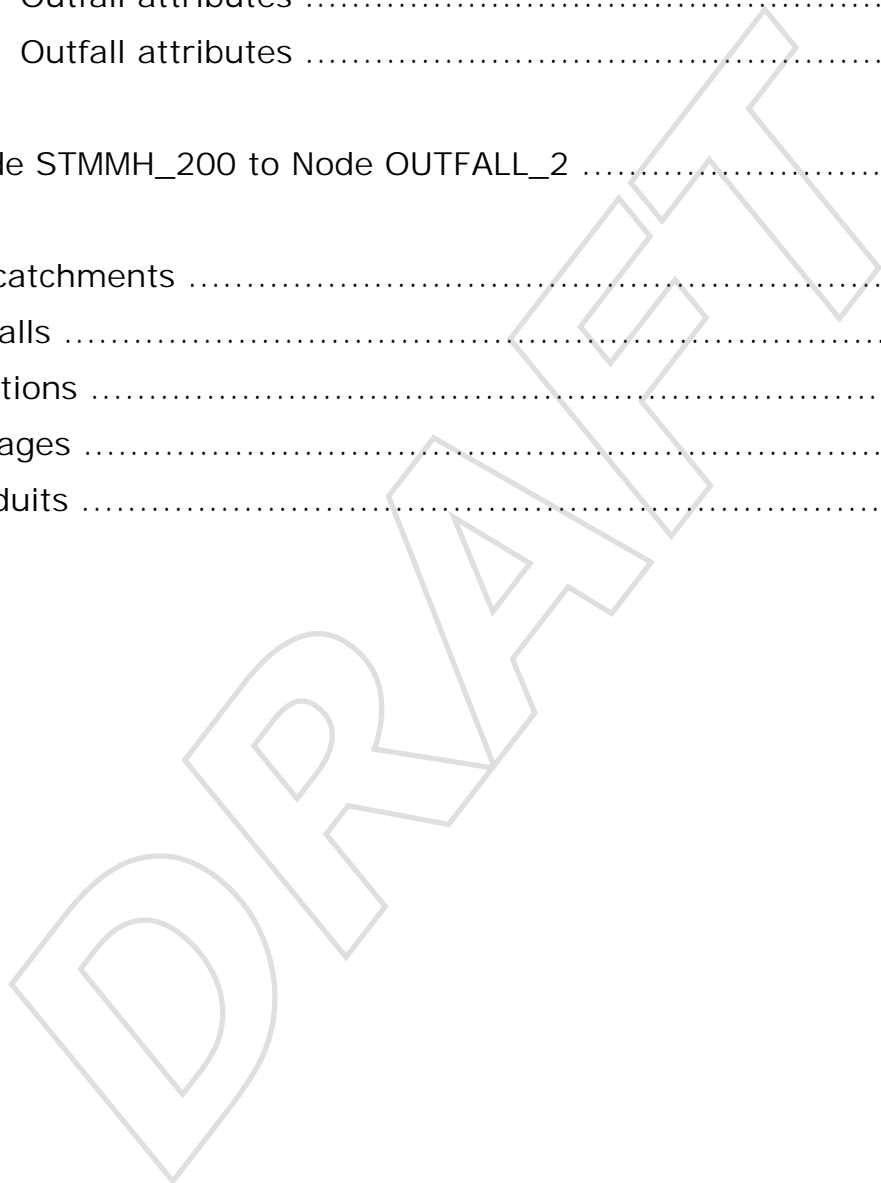

Summary 1A: Subcatchment attributes

Name	Prop_Rev4_SPA_2025	Chicago_3hr_31.9mm_2yr	Chicago_3hr_42.54mm_5yr
B1 - Area (ha)	0.0912	0.0912	0.0912
B2 - Area (ha)	0.0928	0.0928	0.0928
B3 - Area (ha)	0.0927	0.0927	0.0927
B4 - Area (ha)	0.0794	0.0794	0.0794
S100 - Area (ha)	0.0691	0.0691	0.0691
S101 - Area (ha)	0.0372	0.0372	0.0372
S102 - Area (ha)	0.0612	0.0612	0.0612
S103 - Area (ha)	0.0686	0.0686	0.0686
S104 - Area (ha)	0.6319	0.6319	0.6319
S105 - Area (ha)	0.0346	0.0346	0.0346
S106 - Area (ha)	0.0359	0.0359	0.0359
S200 - Area (ha)	0.2265	0.2265	0.2265
S201_2 - Area (ha)	0.1793	0.1793	0.1793
S202 - Area (ha)	1.3325	1.3325	1.3325
S203 - Area (ha)	0.3195	0.3195	0.3195
S204 - Area (ha)	0.0366	0.0366	0.0366
S205 - Area (ha)	0.4653	0.4653	0.4653
S300 - Area (ha)	0.0653	0.0653	0.0653
S301 - Area (ha)	0.1325	0.1325	0.1325
S303 - Area (ha)	0.0719	0.0719	0.0719
B1 - Slope (%)	1.5	1.5	1.5
B2 - Slope (%)	1.5	1.5	1.5
B3 - Slope (%)	1.5	1.5	1.5
B4 - Slope (%)	1.5	1.5	1.5
S100 - Slope (%)	2	2	2
S101 - Slope (%)	2	2	2
S102 - Slope (%)	1.5	1.5	1.5
S103 - Slope (%)	2	2	2
S104 - Slope (%)	1.5	1.5	1.5
S105 - Slope (%)	2	2	2
S106 - Slope (%)	2	2	2
S200 - Slope (%)	2	2	2
S201_2 - Slope (%)	2	2	2
S202 - Slope (%)	1.5	1.5	1.5
S203 - Slope (%)	2.1	2.1	2.1
S204 - Slope (%)	2	2	2
S205 - Slope (%)	1.5	1.5	1.5
S300 - Slope (%)	5	5	5
S301 - Slope (%)	5	5	5

Summary 1A: Subcatchment attributes (continued...)

Name	Prop_Rev4_SPA_2025	Chicago_3hr_31.9mm_2yr	Chicago_3hr_42.54mm_5yr
S303 - Slope (%)	5	5	5
B1 - Imperv. (%)	100	100	100
B2 - Imperv. (%)	100	100	100
B3 - Imperv. (%)	100	100	100
B4 - Imperv. (%)	100	100	100
S100 - Imperv. (%)	61.2	61.2	61.2
S101 - Imperv. (%)	63.6	63.6	63.6
S102 - Imperv. (%)	76	76	76
S103 - Imperv. (%)	22.2	22.2	22.2
S104 - Imperv. (%)	86.4	86.4	86.4
S105 - Imperv. (%)	0	0	0
S106 - Imperv. (%)	0	0	0
S200 - Imperv. (%)	73.2	73.2	73.2
S201_2 - Imperv. (%)	73.9	73.9	73.9
S202 - Imperv. (%)	49.3	49.3	49.3
S203 - Imperv. (%)	33.8	33.8	33.8
S204 - Imperv. (%)	100	100	100
S205 - Imperv. (%)	50.7	50.7	50.7
S300 - Imperv. (%)	100	100	100
S301 - Imperv. (%)	99.1	99.1	99.1
S303 - Imperv. (%)	100	100	100
B1 - Peak Runoff (L/s)	45.16	19.45	26.39
B2 - Peak Runoff (L/s)	45.95	19.79	26.86
B3 - Peak Runoff (L/s)	45.90	19.77	26.83
B4 - Peak Runoff (L/s)	39.31	16.93	22.98
S100 - Peak Runoff (L/s)	32.24	9.53	16.54
S101 - Peak Runoff (L/s)	17.46	5.34	9.13
S102 - Peak Runoff (L/s)	28.43	10.03	14.89
S103 - Peak Runoff (L/s)	28.98	3.85	11.16
S104 - Peak Runoff (L/s)	306.09	117.76	170.69
S105 - Peak Runoff (L/s)	13.72	0.36	4.18
S106 - Peak Runoff (L/s)	14.60	0.44	4.76
S200 - Peak Runoff (L/s)	106.30	36.02	55.46
S201_2 - Peak Runoff (L/s)	84.34	28.78	44.19
S202 - Peak Runoff (L/s)	439.67	140.95	209.31
S203 - Peak Runoff (L/s)	114.80	23.87	44.19
S204 - Peak Runoff (L/s)	18.12	7.81	10.59
S205 - Peak Runoff (L/s)	154.73	50.54	74.57
S300 - Peak Runoff (L/s)	32.33	13.93	18.90

Summary 1A: Subcatchment attributes (continued...)

Name	Prop_Rev4_SPA_2025	Chicago_3hr_31.9mm_2yr	Chicago_3hr_42.54mm_5yr
S301 - Peak Runoff (L/s)	65.51	28.14	38.24
S303 - Peak Runoff (L/s)	35.60	15.34	20.81

Summary 1B: Subcatchment attributes

Name	Chicago_3hr_71.58mm_100yr	Chicago_3hr_85.9mm_100yr+20%
B1 - Area (ha)	0.0912	0.0912
B2 - Area (ha)	0.0928	0.0928
B3 - Area (ha)	0.0927	0.0927
B4 - Area (ha)	0.0794	0.0794
S100 - Area (ha)	0.0691	0.0691
S101 - Area (ha)	0.0372	0.0372
S102 - Area (ha)	0.0612	0.0612
S103 - Area (ha)	0.0686	0.0686
S104 - Area (ha)	0.6319	0.6319
S105 - Area (ha)	0.0346	0.0346
S106 - Area (ha)	0.0359	0.0359
S200 - Area (ha)	0.2265	0.2265
S201_2 - Area (ha)	0.1793	0.1793
S202 - Area (ha)	1.3325	1.3325
S203 - Area (ha)	0.3195	0.3195
S204 - Area (ha)	0.0366	0.0366
S205 - Area (ha)	0.4653	0.4653
S300 - Area (ha)	0.0653	0.0653
S301 - Area (ha)	0.1325	0.1325
S303 - Area (ha)	0.0719	0.0719
B1 - Slope (%)	1.5	1.5
B2 - Slope (%)	1.5	1.5
B3 - Slope (%)	1.5	1.5
B4 - Slope (%)	1.5	1.5
S100 - Slope (%)	2	2
S101 - Slope (%)	2	2
S102 - Slope (%)	1.5	1.5
S103 - Slope (%)	2	2
S104 - Slope (%)	1.5	1.5
S105 - Slope (%)	2	2
S106 - Slope (%)	2	2
S200 - Slope (%)	2	2
S201_2 - Slope (%)	2	2

Summary 1B: Subcatchment attributes (continued...)

Name	Chicago_3hr_71.58mm_100yr	Chicago_3hr_85.9mm_100yr+20%
S202 - Slope (%)	1.5	1.5
S203 - Slope (%)	2.1	2.1
S204 - Slope (%)	2	2
S205 - Slope (%)	1.5	1.5
S300 - Slope (%)	5	5
S301 - Slope (%)	5	5
S303 - Slope (%)	5	5
B1 - Imperv. (%)	100	100
B2 - Imperv. (%)	100	100
B3 - Imperv. (%)	100	100
B4 - Imperv. (%)	100	100
S100 - Imperv. (%)	61.2	61.2
S101 - Imperv. (%)	63.6	63.6
S102 - Imperv. (%)	76	76
S103 - Imperv. (%)	22.2	22.2
S104 - Imperv. (%)	86.4	86.4
S105 - Imperv. (%)	0	0
S106 - Imperv. (%)	0	0
S200 - Imperv. (%)	73.2	73.2
S201_2 - Imperv. (%)	73.9	73.9
S202 - Imperv. (%)	49.3	49.3
S203 - Imperv. (%)	33.8	33.8
S204 - Imperv. (%)	100	100
S205 - Imperv. (%)	50.7	50.7
S300 - Imperv. (%)	100	100
S301 - Imperv. (%)	99.1	99.1
S303 - Imperv. (%)	100	100
B1 - Peak Runoff (L/s)	45.16	54.19
B2 - Peak Runoff (L/s)	45.95	55.14
B3 - Peak Runoff (L/s)	45.90	55.08
B4 - Peak Runoff (L/s)	39.31	47.18
S100 - Peak Runoff (L/s)	32.24	39.28
S101 - Peak Runoff (L/s)	17.46	21.22
S102 - Peak Runoff (L/s)	28.43	34.82
S103 - Peak Runoff (L/s)	28.98	36.59
S104 - Peak Runoff (L/s)	306.09	369.52
S105 - Peak Runoff (L/s)	13.72	17.73
S106 - Peak Runoff (L/s)	14.60	18.64
S200 - Peak Runoff (L/s)	106.30	129.71

Summary 1B: Subcatchment attributes (continued...)

Name	Chicago_3hr_71.58mm_100yr	Chicago_3hr_85.9mm_100yr+20%
S201_2 - Peak Runoff (L/s)	84.34	102.83
S202 - Peak Runoff (L/s)	439.67	568.36
S203 - Peak Runoff (L/s)	114.80	151.59
S204 - Peak Runoff (L/s)	18.12	21.75
S205 - Peak Runoff (L/s)	154.73	199.35
S300 - Peak Runoff (L/s)	32.33	38.80
S301 - Peak Runoff (L/s)	65.51	78.64
S303 - Peak Runoff (L/s)	35.60	42.72

Summary 2A: Outfall attributes

Name	Prop_Rev4_SPA_2025	Chicago_3hr_31.9mm_2yr	Chicago_3hr_42.54mm_5yr
OUTFALL_1 - Max. Flow (L/s)	572.97	222.48	320.53
OUTFALL_1A - Max. Flow (L/s)	480.73	46.84	99.84
OUTFALL_2 - Max. Flow (L/s)	336.63	207.42	289.25
OUTFALL_3 - Max. Flow (L/s)	153.64	50.34	74.10
OUTFALL_4 - Max. Flow (L/s)	32.33	13.93	18.90

Summary 2B: Outfall attributes

Name	Chicago_3hr_71.58mm_100yr	Chicago_3hr_85.9mm_100yr+20%
OUTFALL_1 - Max. Flow (L/s)	572.97	688.13
OUTFALL_1A - Max. Flow (L/s)	480.73	683.31
OUTFALL_2 - Max. Flow (L/s)	336.63	358.94
OUTFALL_3 - Max. Flow (L/s)	153.64	197.50
OUTFALL_4 - Max. Flow (L/s)	32.33	38.80

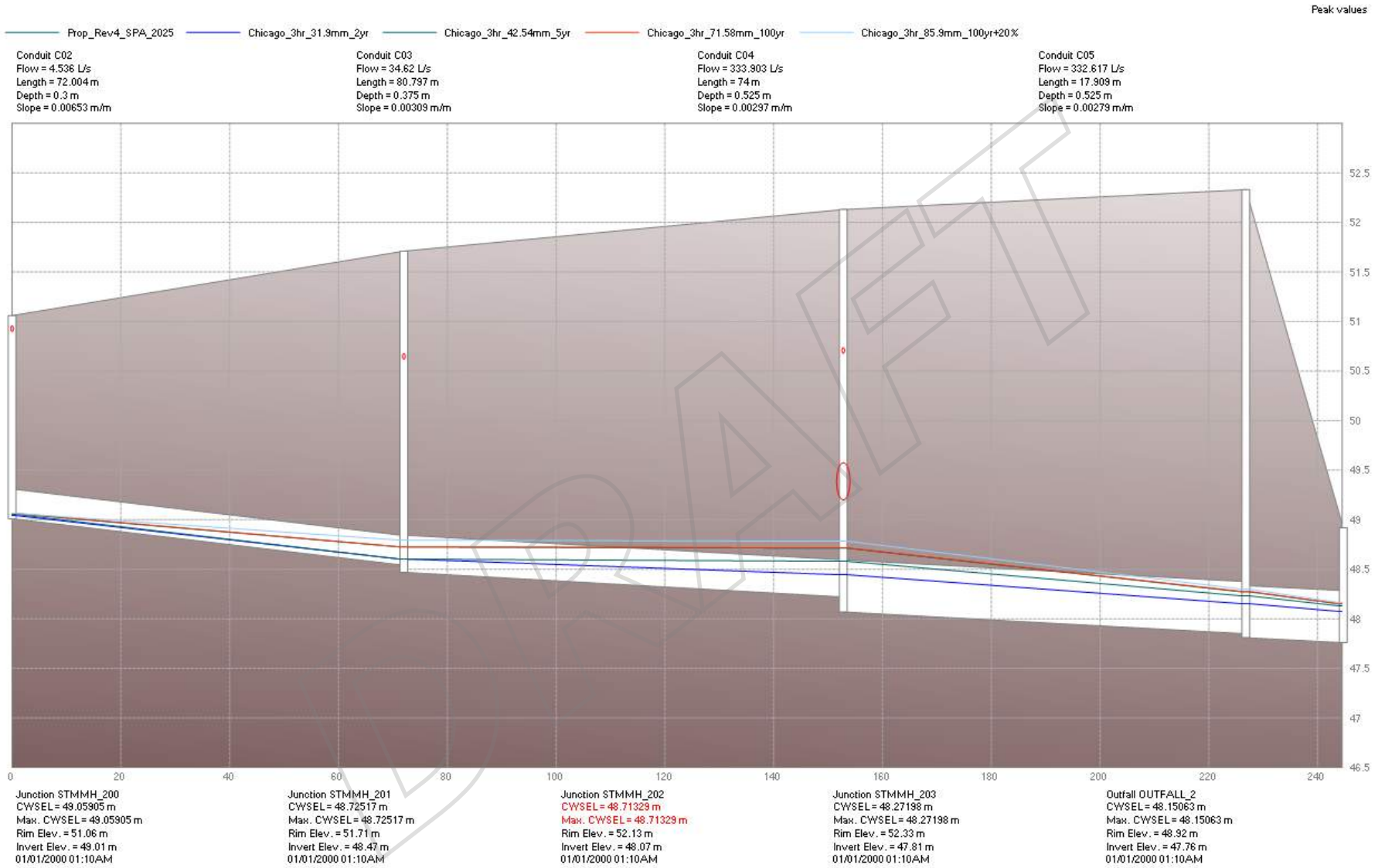

Figure 1: Node STMMH_200 to Node OUTFALL_2

Table 1: Subcatchments

Name	Imperv. (%)	CAVG	Area (ha)
B1	100	0.9	0.0912
B2	100	0.9	0.0928
B3	100	0.9	0.0927
B4	100	0.9	0.0794
S100	61.2	0.63	0.0691
S101	63.6	0.65	0.0372
S102	76	0.73	0.0612
S103	22.2	0.36	0.0686
S104	86.4	0.8	0.6319
S105	0	0.2	0.0346
S106	0	0.2	0.0359
S200	73.2	0.71	0.2265
S201_2	73.9	0.72	0.1793
S202	49.3	0.55	1.3325
S203	33.8	0.44	0.3195
S204	100	0.9	0.0366
S205	50.7	0.55	0.4653
S300	100	0.9	0.0653
S301	99.1	0.89	0.1325
S303	100	0.9	0.0719

Table 2: Outfalls

Name	Tag	Inflows	Invert Elev. (m)	Rim Elev. (m)	Tide Gate	Type	Fixed Stage (m)
OUTFALL_1	POST	NO	43	44	NO	FREE	0
OUTFALL_1A	TWEDDLE	NO	43	44	NO	FREE	0
OUTFALL_2	JDA	NO	47.76	48.92	NO	FREE	0
OUTFALL_3	TWEDDLE	NO	50.05	51	NO	FREE	0
OUTFALL_4	TWEDDLE	NO	43.2	43.2	NO	FREE	0

Table 3: Junctions

Name	Invert Elev. (m)	Rim Elev. (m)	Depth (m)
EX_DI_1	50	52.32	2.32
EX_DI_2	49.8	52.15	2.35
J01	50.11	50.26	0.15
J02	44.13	44.28	0.15
J03	50.11	50.26	0.15
J04	45.3	45.45	0.15
STMMH_200	49.01	51.06	2.05
STMMH_201	48.47	51.71	3.24
STMMH_202	48.07	52.13	4.06
STMMH_203	47.81	52.33	4.52
SU1	50.15	51.35	1.2

Table 4: Storages

Name	Invert Elev. (m)	Rim Elev. (m)	Depth (m)	Storage Curve
CB_1	49.5	51.05	1.55	TABULAR
CB_2	50.62	52.17	1.55	TABULAR
CB_3	50.68	52.23	1.55	TABULAR
OGS	48.3	52.1	3.8	TABULAR
ROOF_B1	142	142.15	0.15	TABULAR
ROOF_B2	142	142.15	0.15	TABULAR
ROOF_B3	142	142.15	0.15	TABULAR
ROOF_B4	142	142.15	0.15	TABULAR

Table 5: Conduits

Name	Inlet Node	Outlet Node	Length (m)	Roughness	Inlet Elev. (m)	Outlet Elev. (m)	Cross-Section	Geom1 (m)
C01	SU1	OUTFALL_3	35.94	0.024	50.15	50.05	CIRCULAR	0.5
C02	STMMH_200	STMMH_201	72.004	0.013	49.01	48.54	CIRCULAR	0.3
C03	STMMH_201	STMMH_202	80.797	0.013	48.47	48.22	CIRCULAR	0.375
C04	STMMH_202	STMMH_203	74	0.013	48.07	47.85	CIRCULAR	0.525
C05	STMMH_203	OUTFALL_2	17.909	0.013	47.81	47.76	CIRCULAR	0.525
C06	CB_3	CB_2	90.647	0.013	52.08	52.02	IRREGULAR	0
C07	J01	J02	117.008	0.013	50.11	44.13	IRREGULAR	0
C08	OGS	OUTFALL_1	39.565	0.013	48.3	43	CIRCULAR	0.6

Table 5: Conduits (continued...)

Name	Inlet Node	Outlet Node	Length (m)	Roughness	Inlet Elev. (m)	Outlet Elev. (m)	Cross-Section	Geom1 (m)
C09	CB_2	CB_1	94.246	0.013	52.02	50.9	IRREGULAR	0
C10	EX_DI_2	STMMH_202	13.896	0.024	49.8	49.2	CIRCULAR	0.375
C11	EX_DI_1	EX_DI_2	37.18	0.024	50	49.8	CIRCULAR	0.375
C12	CB_1	J01	23.03	0.013	50.9	50.11	IRREGULAR	0
C13	J02	OUTFALL_1A	50.682	0.035	44.13	43	TRAPEZOIDAL	0.5
C14	J03	J04	91.427	0.013	50.11	45.3	IRREGULAR	0
C15	J04	OUTFALL_4	14.75	0.035	45.3	43.2	TRAPEZOIDAL	0.5
C17	EX_DI_1	CB_2	37.03	0.013	52.17	52.02	RECT_OPEN	0.15

DRAFT