



URBAN FORESTRY & FOREST MANAGEMENT CONSULTING

P.O. Box 13593, STN. KANATA, OTTAWA, ON K2K 1X6  
TELEPHONE: (613) 850-2475  
WEBSITE: WWW.IFSASSOCIATES.CA

March 16, 2026

John Szczepaniak, Landscape Architect  
P.O. Box 4207, Station 'E'  
Ottawa, ON  
K1S 5B2

**RE: (REVISED) TREE CONSERVATION REPORT FOR 3055 RICHMOND ROAD, OTTAWA**

This Tree Conservation Report (TCR) was prepared by IFS Associates Inc. (IFS) in support of the proposed redevelopment of 3055 Richmond Road in Ottawa. The need for this report is related to trees protected under the City of Ottawa's Tree Protection By-law (By-law No. 2020-340). Presently the subject property is occupied by a single-family house. The proposed redevelopment will include the demolition of the existing dwelling and construction of a 4-storey low rise apartment building with surrounding surface parking and amenity areas.

Under the Tree Protection By-law a TCR is required for all Plans of Subdivision, Site Plan Control Applications, Common Elements Condominium Applications, and Vacant Land Condominium Applications where there is a tree of 10 cm in diameter at breast height (DBH) or greater on a site and/or if there is a tree on an adjacent site that has a critical root zone (CRZ) extending onto a development site. Trees of any size on adjacent City lands must also be documented in a TCR. A "tree" is defined in the By-law as any species of woody perennial plant, including its root system, which has reached or can reach a minimum height of at least 450 cm at physiological maturity. The CRZ is calculated as DBH x 10 cm.

The approval of this TCR by the City of Ottawa and the issuing of a permit by them authorize the removal of approved trees. Importantly, although this report may be used to support the application for a City tree removal permit, it does not by itself constitute permission to remove trees or begin site clearing activities. No such work should occur before a tree removal permit is issued by the City's General Manager authorizing the injury or destruction of a tree in accordance with the by-law.

The inventory in this report details the assessment of all individual trees on the subject and adjacent private property, including trees on nearby City of Ottawa property. Field work for this report was completed in April 2022 and September 2025.

**TREE SPECIES, CONDITION, SIZE AND STATUS**

Table 1 on pages 2 through 6 of this report details the species, condition, size (diameter) and status of the individual trees on and adjacent to the subject property. Each of these trees is referenced by the numbers plotted on the tree conservation plans included on pages 9 and 10 of this report.



Table 1. Species, condition, size, ownership and status of trees at 3055 Richmond Road.

Tree No.	Tree species	Condition (very poor → excellent)	DBH <sup>1</sup> (cm)	CRZ <sup>2</sup> (cm)	Ownership	Age class, tree condition notes, species origin & <b>preservation status</b> (to be removed or preserved and protected)
1	White elm ( <i>Ulmus americana</i> )	Fair	17 avg.		City	Maturing; tri-stemmed at 0.2m from grade; central stem with two suppressed upright laterals; all stems mildly-moderately divergent towards northeast; no outward signs of Dutch elm disease ( <i>Ophiostoma novo-ulmi</i> )-DED; native species; <b>to be preserved and protected</b>
2	White cedar ( <i>Thuja occidentalis</i> )	-	15.1		City	<b>Previously removed</b>
3	White elm ( <i>Ulmus americana</i> )	Dead	17.6 & 19.1		City	<b>Standing dead</b>
4	White elm ( <i>Ulmus americana</i> )	Dead	13.7		City	<b>Standing dead</b>
5	White elm ( <i>Ulmus americana</i> )	Fair	20.7		City	Maturing; single stem; very asymmetric towards east; no outward signs of DED; native species; <b>to be preserved and protected</b>
6	White elm ( <i>Ulmus americana</i> )	Good	33.9		City	Mature; co-dominant stems at 2.5m from grade; crown broadens above surrounding trees; no outward signs of DED; native species; <b>to be preserved and protected</b>
7	White elm ( <i>Ulmus americana</i> )	Dead	38.7 & 52.2 (at 2.5m)		Private	Very mature; double stemmed at 1.75m from grade; both divergent towards north due to influence of tree #8; both stems bisect at 5-5.5m - crown broadens above this height; growing into retaining wall (grade change of +/-1.5m); outward signs of DED; native species; <b>to be removed</b> (dead)

Table 1. Cont.

Tree No.	Tree species	Condition (very poor → excellent)	DBH <sup>1</sup> (cm)	CRZ <sup>2</sup> (cm)	Owner-ship	Age class, tree condition notes, species origin & <b>preservation status</b> (to be removed or preserved and protected)
8	Silver maple ( <i>Acer saccharinum</i> )	Fair	93.1 (at 0.2m)		Private	Very mature; co-dominant stems at 3m – both bisect at 5.5m; very broad crown; asymmetric towards south due to influence of tree #7; pockets of decay and major deadwood in upper crown; growing into retaining wall; native species; <b>to be removed</b> (will not survive future grade change)
9	Crab apple ( <i>Malus</i> spp.)	Poor	17 avg.		Private	Overmature; five stemmed from grade; central stem dead, hollow; heavily asymmetric towards south due to influence of tree #8; cultivar; <b>recommended for removal due to condition</b>
10	Willow ( <i>Salix</i> spp.)	Very poor	51.7		Private	Overmature; opposing wounds in lower bole with advanced decay; hazardous; native species; <b>recommended for removal due to condition</b>
11	Crab apple ( <i>Malus</i> spp.)	Fair	15 avg.		Private	Very mature; seven stemmed at grade-0.5m; heavy basal sprouting; heavily asymmetric towards west due to influence of tree #10; cultivar; <b>to be removed</b> (conflicts with driveway)
12	White spruce ( <i>Picea glauca</i> )	Fair	+30		Neighbour	Mature; topped by Hydro at 7m; lateral now dominant leader; suppressed lateral at 5m; fair crown density, annual increment and needle colour; native species; <b>to be preserved and protected</b>

Table 1. Cont.

Tree No.	Tree species	Condition (very poor → excellent)	DBH <sup>1</sup> (cm)	CRZ <sup>2</sup> (cm)	Ownership	Age class, tree condition notes, species origin & <b>preservation status</b> (to be removed or preserved and protected)
13	Balsam fir ( <i>Abies balsamea</i> )	Good	+/-20		Neighbour	Maturing; single upright stem with competing leaders; good crown density, annual increment and needle colour in upper crown; native species; <b>to be preserved and protected</b>
14	Crab apple ( <i>Malus</i> spp.)	Good	14.0		Neighbour	Maturing; main stem with competing lateral at 1m on south now dominant; cultivar; <b>to be preserved and protected</b>
15	Norway maple ( <i>Acer platanoides</i> )	Very good	18.5		Neighbour	Maturing; single dominant stem and leaders - generally upright form; introduced invasive species; <b>to be preserved and protected</b>
16	Mountain-ash ( <i>Sorbus</i> spp.)	Poor	13.1		Private	Mature; generally upright form but in advanced decline; native species; <b>to be removed</b> (conflicts with driveway construction)
17	Crab apple ( <i>Malus</i> spp.)	Good	22.1		Private	Mature; tri-dominant stems at 3.25m from grade; broad crown; cultivar; <b>to be removed</b> (conflicts with driveway construction)
18	Crab apple ( <i>Malus</i> spp.)	Fair	20.5		Private	Mature; lower stem divergent and crown asymmetric towards northeast due to influence of tree #20; cultivar; <b>to be removed</b> (conflicts with driveway construction)

Table 1. Cont.

Tree No.	Tree species	Condition (very poor → excellent)	DBH <sup>1</sup> (cm)	CRZ <sup>2</sup> (cm)	Ownership	Age class, tree condition notes, species origin & <b>preservation status</b> (to be removed or preserved and protected)
19	Manitoba maple ( <i>Acer negundo</i> )	Very poor	72.1		Private	Overmature; competing stem previously removed at 1.75m on north leaving huge wound; wound with cavity at 3.5m on east; remaining stem divergent towards east due to influence of previous stem; lower suppressed lateral at 3.5m on southwest is on far side of cavity – potentially hazardous; naturalized species; <b>to be removed</b> (conflicts with construction & very poor condition)
20	Manitoba maple ( <i>Acer negundo</i> )	Fair	+/-40		Neighbour	Mature; moderately divergent towards south due to influence of tree #21; naturalized species; <b>to be preserved and protected</b>
21	Siberian elm ( <i>Ulmus pumila</i> )	Good	+/-40		Neighbour	Mature; upright form with co-dominant leaders at 8m and competing lateral at 7m on northeast; introduced invasive species; <b>to be preserved and protected</b>
22	Crab apple ( <i>Malus</i> spp.)	Good	12.2		Private	Maturing; divergent form towards west; cultivar; <b>to be preserved and protected</b>
23	Crab apple ( <i>Malus</i> spp.)	Good	15.8		Private	Maturing; generally upright form; cultivar; <b>to be preserved and protected</b>
24	Norway maple ( <i>Acer platanoides</i> )	Good	+/-15		Neighbour	Generally upright form with co-dominant leaders; introduced invasive species; <b>to be preserved and protected</b>

Table 1. Cont.

Tree No.	Tree species	Condition (very poor → excellent)	DBH <sup>1</sup> (cm)	CRZ <sup>2</sup> (cm)	Ownership	Age class, tree condition notes, species origin & <b>preservation status</b> (to be removed or preserved and protected)
25	White pine ( <i>Pinus strobus</i> )	Fair	37.4		Private	Mature; single dominant stem and leader; lower and mid-crown heavily asymmetric towards south due to influence of tree #26; fair crown density, annual increment and needle colour; native species; <b>to be preserved and protected</b>
26	Silver maple ( <i>Acer saccharinum</i> )	Fair	41 avg.		Private	Mature; five stemmed at grade; central stem broken at 9m, all other stems all moderately divergent; native species; <b>to be preserved and protected</b>
27	White spruce ( <i>Picea glauca</i> )	Fair	+/-40		Neighbour	Mature; living crown held at half height due to influence of surrounding trees; some vine ( <i>Vitis</i> spp.) growth into crown; fair crown density, annual increment and needle colour; native species; <b>to be preserved and protected</b>

<sup>1</sup> Diameter at breast height, or 1.4m from grade (unless otherwise indicated); <sup>2</sup> Critical root zone (CRZ) is 10 centimetres from the trunk of a tree for every centimetre of DBH. The CRZ is calculated as DBH x 10 cm

Pictures 1 to 6 on pages 13 through 17 of this report show selected trees on and adjacent to the subject property. All pictures were taken in April 2022.

### TREE PRESERVATION DISCUSSION

The proposed grading between the driveway and western property line will not be detrimental to neighboring trees #12, 13, 14, 15, 20 and 21 for two reasons: i) in all cases the amount of the CRZs affected will be less than 30% (the maximum prescribed in ISA best management practices) and ii) the relative youth of trees #12, 13 and 14 and hardiness of trees #15, 20 and 21 will allow them to easily adapt over time to the changes within their growing environment.

## FEDERAL AND PROVINCIAL REGULATIONS

Federal and provincial regulations can be applicable to trees on private property. In particular, the following two regulations have been considered for this property:

- 1) Endangered Species Act (2007): No butternuts (*Juglans cinerea*) or black ash (*Fraxinus nigra*) were identified on the subject or adjacent properties. This species of tree is listed as threatened under the Province of Ontario's Endangered Species Act (2007) and so is protected from harm.
- 2) Migratory Bird Convention Act (1994): In the period between April and August of each year nest surveys are required to be performed by a suitably trained person no more than five (5) days before trees or other similar nesting habitat are to be removed.

## TREE PRESERVATION MEASURES

As excavation will be within the CRZs of several trees, in particular trees #12, 13, 14, 15, 20 and 21, the following measures will be taken:

1. Air excavation along the edge of the driveway in proximity to the trees to carefully expose roots. Exposed roots will then be cleanly cut and sealed before being reburied (see City of Ottawa root pruning detail on page 11). Excavation can then resume using traditional mechanical means. Sealing the cleanly cut root ends with a beeswax product will help prevent the loss of moisture and facilitate healing. An arborist and a City forestry inspector will be present during the air excavation and root pruning to assess the stability and viability of retained trees. If any trees are thought to be terminally impacted by the driveway and related grade changes, the neighbouring property owner will be alerted and their permission to remove them will be sought.
2. If the excavation is to be left open for any length of time a covering of at least three layers of moistened burlap is to be draped over the exposed face of excavation closet to the tree. A final covering of clear plastic or white tarp will help retain moisture within the burlap. The use of burlap and coverings will help reduce the loss of moisture from the soil surrounding the remaining roots.

## TREE PROTECTION MEASURES

Preservation and protection measures intended to mitigate damage during construction will be applied for all trees to be retained. The following measures are the minimum required by the City of Ottawa to ensure tree survival during and following construction:

1. Erect a fence at the critical root zone (CRZ<sup>1</sup>) of trees (see City of Ottawa tree protection barrier specification on page 12).

2. Do not place any material or equipment within the CRZ of the tree.
3. Do not attach any signs, notices or posters to any tree.
4. Do not raise or lower the existing grade within the CRZ without approval.
5. Tunnel or bore when digging within the CRZ of a tree.
6. Do not damage the root system, trunk or branches of any tree.
7. Ensure that exhaust fumes from all equipment are NOT directed towards any tree's crown.

<sup>1</sup> The critical root zone (CRZ) is established as being 10 centimetres from the trunk of a tree for every centimetre of trunk diameter at breast height (DBH). The CRZ is calculated as DBH x 10 cm.

This report is subject to the attached Limitations of Tree Assessments and Liability to which the reader's attention is directed.

Please do not hesitate to contact the undersigned with any questions concerning this report.

Yours,



Andrew K. Boyd, B.Sc.F, R.P.F. (#1828)  
Certified Arborist #ON-0496A  
Consulting Urban Forester

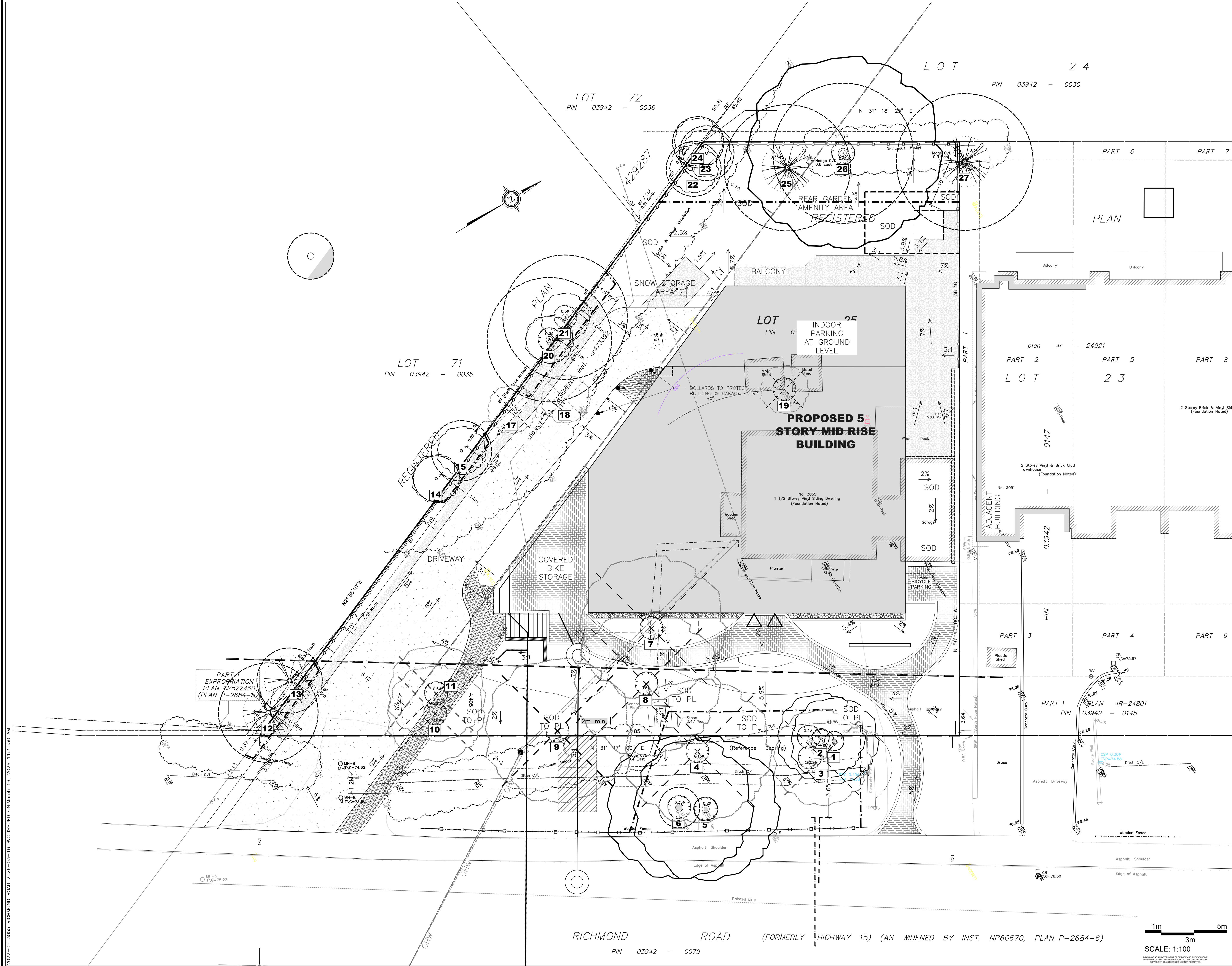

**LEGEND**

- EXISTING EVERGREEN TREE [DASHED CIRCLE REFERS TO THE CRITICAL ROOT ZONE]
- EXISTING DECIDUOUS TREE [DASHED CIRCLE REFERS TO THE CRITICAL ROOT ZONE]
- EXISTING EVERGREEN TREE TO BE REMOVED
- EXISTING DECIDUOUS TREE TO BE REMOVED
- TREE PROTECTION FENCE

16	April 08/25	Issued for resubmission
17	April 23/25	Adjustments as per eng. dwgs
18	May 15/25	Adjustments as per eng. comments
19	Sept 02/25	Adjustments as per new stair and walkway align.
20	Sept 03/25	Additional adjustments
21	Nov 03/25	Minor Adjustments
22	Nov 24/25	CRZ noted for trees and driveway align. revised
23	Dec 19/25	Transformer location adjusted
24	Jan 05/26	Issue for resubmission
25	Mar 09/26	Re issued in response to Feb. 24th 2026 comments

No.	Date	Revision note
-----	------	---------------

**John K. Szczepaniak**  
 LANDSCAPE ARCHITECT  
 REG. NO. 10000  
 tel: (613) 731-2777 fax: (613) 731-6989  
 e-mail: jszla@rogers.com

**3055 Richmond Road**  
 3055 Richmond Road,  
 Ottawa

**Tree Conservation Plan**

CHK: JKS  
 DRW: EK  
 DATE: April 25, 2022  
 ID: 2022-05  
 SCALE: 1:100

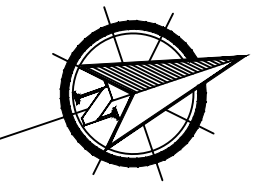

2022-05-30 5:36:55 PM RICHMOND ROAD 2026-03-16 DWG ISSUED ON March 16, 2026 11:30:59 AM

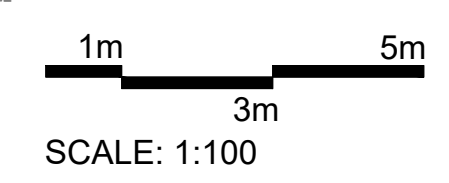

SCALE: 1:100

RICHMOND ROAD (FORMERLY HIGHWAY 15) (AS WIDENED BY INST. NP6070, PLAN P-2684-6)  
 PIN 03942 - 0079



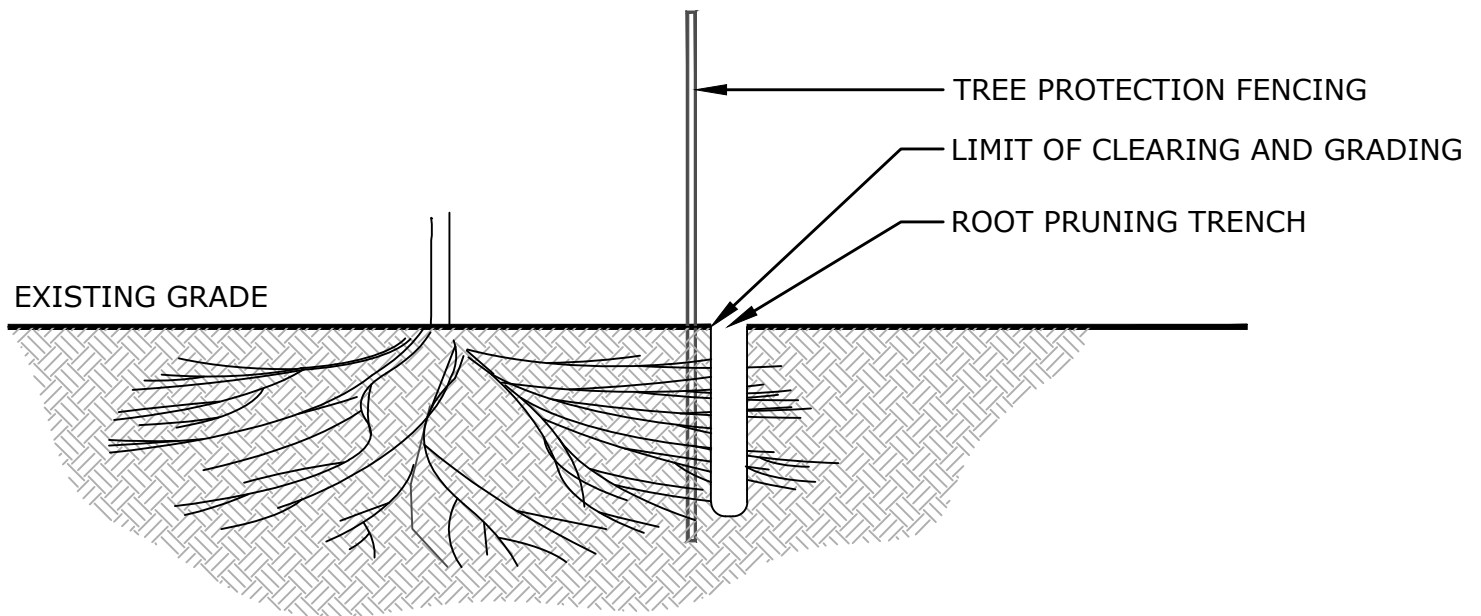

NOTES:

1. PROPER ROOT PRUNING TECHNIQUES REQUIRED WHEN TREE ROOTS ARE ENCOUNTERED DURING EXCAVATION.
2. EXCAVATION (ROOT PRUNING TRENCH) SHALL BE CARRIED OUT BY TUNNELING, BORING OR HYDRO VAC.
3. ROOTS ARE TO BE CLEANLY CUT AND THE AREA AROUND THE ROOTS SHALL BE BACKFILLED WITH SUITABLE MATERIAL, AS DETAILED IN THE CONTRACT DRAWINGS.
4. TREES SHALL BE PRUNED TO RESTORE TREE APPEARANCE AND/OR RESTORE THE BALANCE BETWEEN TOP GROWTH AND ROOTS.
5. LEADERS SHALL NOT BE PRUNED.

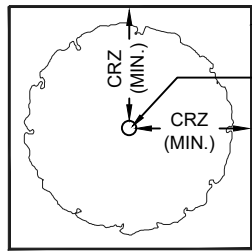

TREE PROTECTION FENCING  
TREE TRUNK

PLAN VIEW

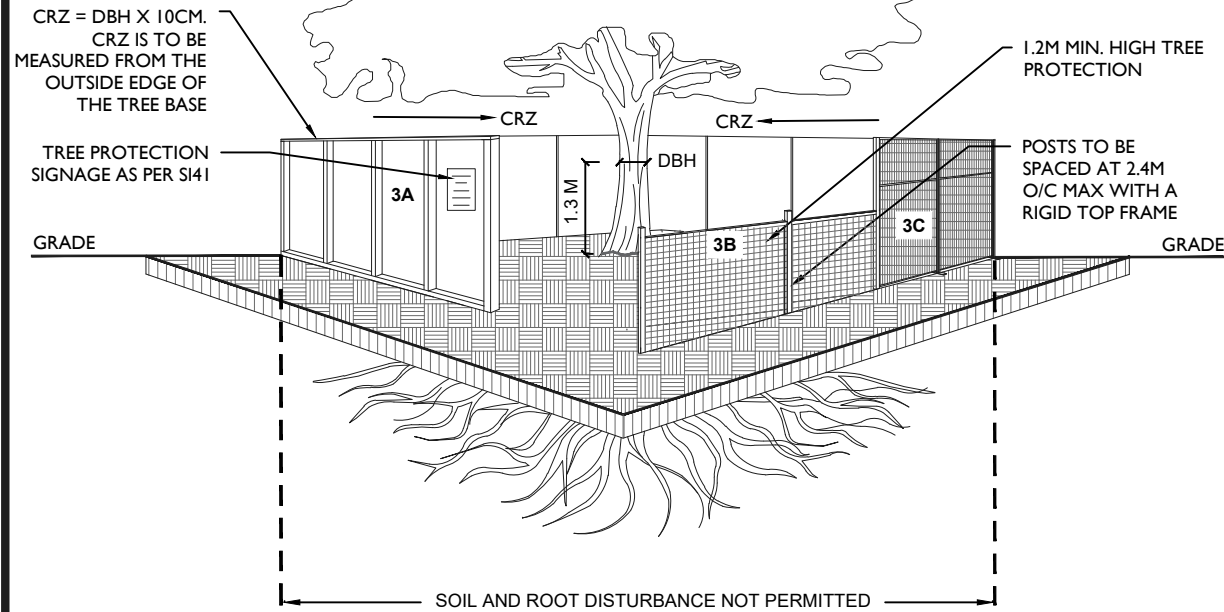

TREE PROTECTION REQUIREMENTS:

1. TREE PROTECTION FENCING MUST BE INSTALLED PER THE TREE CONSERVATION REPORT (TCR) OR THE TREE INFORMATION REPORT (TIR), WHICH EVER APPLIES, AND MUST BE DETERMINED BY AN ARBORIST AND APPROVED BY CITY FORESTRY STAFF PRIOR TO THE COMMENCEMENT OF THE WORK AND REMAIN IN PLACE UNTIL THE WORK IS COMPLETE.
  2. FOR WORK WITHIN THE TREE PROTECTION ZONE (TPZ):
    - DO NOT PLACE OR STORE ANY MATERIAL, FILL OR EQUIPMENT (INCLUDING OUTHOUSES)
    - DO NOT ATTACH ANY SIGNS, NOTICES OR POSTERS TO ANY TREE.
    - DO NOT RAISE OR LOWER THE EXISTING GRADE (SCRAPING OF THE TOP LAYER OF SOIL FOR FINAL GRADING MUST BE AVOIDED WITHIN THE CRZ, THIS INCLUDES FINAL LANDSCAPE/ REINSTATEMENT GRADING).
    - ENSURE THAT EXHAUST FUMES FROM ALL EQUIPMENT ARE DIRECTED AWAY FROM THE TREE CANOPY
    - DO NOT EXTEND/REINSTATE HARD SURFACE WITHIN THE CRZ
    - DO NOT DISPOSE OF WASTE OR VOLATILE MATERIALS, SUCH AS MINERAL SPIRITS, OIL OR PAINT THINNER
    - DO NOT OPERATE, PARK, REPAIR, OR REFUEL VEHICLES OR EQUIPMENT.
    - DO NOT DAMAGE THE ROOT SYSTEM, TRUNK OR BRANCHES OF ANY TREE
    - EXCAVATION SHALL BE CARRIED OUT BY TUNNELING, BORING OR HYDRO VAC
  3. TREE PROTECTION FENCING MUST BE AT LEAST 1.2M IN HEIGHT AND BE CONSTRUCTED OF RIGID OR FRAMED MATERIALS SUCH AS:
    - A. PLYWOOD HOARDING
    - B. SNOW FENCE
    - C. MODULAR STEEL PANELS
- INSTALLATION OF ALL FENCING TYPES, A, B OR C, MUST MINIMIZE DAMAGE TO EXISTING ROOTS.
4. ANY DEVIATION TO THE APPROVED TREE PROTECTION FENCING LOCATION MUST BE SUPERVISED BY AN ARBORIST AND APPROVED BY CITY FORESTRY STAFF. MODIFICATIONS MAY INCLUDE THE INSTALLATION OF PLYWOOD, WOOD CHIPS, OR STEEL PLATING OVER THE ROOTS, OR PERFORMING PROPER ROOT PRUNING AND CARE WHERE ROOTS ARE ENCOUNTERED.
  5. IF TREES ARE BEING AFFECTED BY CONSTRUCTION, A WATER AND FERTILIZING PROGRAM MAY BE REQUIRED.
  6. THE CITY OF OTTAWA'S TREE PROTECTION BY-LAW (NO. 2020-340) AND STANDARD F-8011 APPLY



Tree Protection

SCALE: NTS

DATE: JANUARY 2026

DRAWING NO.: F7



Picture 1. Trees #4, 5 and 6 (right to left), white elms on city property adjacent to 3055 Richmond Road



Picture 2. Trees #7 and 8 (left to right) private white elm and silver maple at 3055 Richmond Road (note existing grade change/retaining wall)



Picture 3. Trees #14-18 (left to right), private crab apples, Norway maple and mountain-ash at 3055 Richmond Road



Picture 4. Trees #20 and 21 (centre, left to right), neighbouring Manitoba maple and Siberian elm adjacent to 3055 Richmond Road



Picture 5. Tree #19, private Manitoba maple at 3055 Richmond Road





Picture 6. Trees #25, 26 and 27 (left to right), private white pine, silver maple and neighbouring white spruce at 3055 Richmond Road

# LIMITATIONS OF TREE ASSESSMENTS & LIABILITY

## GENERAL

It is the policy of *IFS Associates Inc.* to attach the following clause regarding limitations. We do this to ensure that our clients are clearly aware of what is technically and professionally realistic in assessing trees for retention.

This report was carried out by *IFS Associates Inc.* at the request of the client. The information, interpretation and analysis expressed in this report are for the sole benefit and exclusive use of the client. Possession of this report or a copy thereof does not imply right of publication or use for any purpose by any other than the client to whom it is addressed. Unless otherwise required by law, neither all or any part of the contents of this report, nor copy thereof, shall be conveyed by anyone, including the client, to the public through public relations, news or other media, without the prior expressly written consent of the author, and especially as to value conclusions, identity of the author, or any reference to any professional society or institute or to any initialed designation conferred upon the author as stated in his qualifications.

This report and any values expressed herein represent the opinion of the author; his fee is in no way contingent upon the reporting of a specified value, a stipulated result, nor upon any finding to be reported.

Details obtained from photographs, sketches, *etc.*, are intended as visual aids and are not to scale. They should not be construed as engineering reports or surveys. Although every effort has been made to ensure that this assessment is reasonably accurate, the tree(s) should be reassessed at least annually. The assessment presented in this report is valid at the time of the inspection only. The loss or alteration of any part of this report invalidates the entire report.

## LIMITATIONS

The information contained in this report covers only the tree(s) in question and no others. It reflects the condition of the assessed tree(s) at the time of inspection and was limited to a visual examination of the accessible portions only. *IFS Associates Inc.* has prepared this report in a manner consistent with that level of care and skill ordinarily exercised by members of the forestry and arboricultural professions, subject to the time limits and physical constraints applicable to this report. The assessment of the tree(s) presented in this report has been made using accepted arboricultural techniques. These include a visual examination of the above-ground portions of each tree for structural defects, scars, cracks, cavities, external indications of decay such as fungal fruiting bodies, evidence of insect infestations, discoloured foliage, the condition of any visible root structures, the degree and direction of lean (if any), the general condition of the tree(s) and the surrounding site, and the proximity of people and property. Except where specifically noted in the report, the tree(s) examined were not dissected, cored, probed or climbed to gain further evidence of their structural condition. Also, unless otherwise noted, no detailed root collar examinations involving excavation were undertaken.

While reasonable efforts have been made to ensure that the tree(s) proposed for retention are healthy, no warranty or guarantee, expressed or implied, are offered that these trees, or any parts of them, will remain standing. This includes other trees on or off the property not examined as part of this assignment. It is both professionally and practically impossible to predict with

absolute certainty the behaviour of any single tree or groups of trees or their component parts in all circumstances, especially when within construction zones. Inevitably, a standing tree will always pose some risk. Most trees have the potential for failure in the event of root loss due to excavation and other construction-related impacts. This risk can only be eliminated through full tree removal.

Notwithstanding the recommendations and conclusions made in this report, it must be realized that trees are living organisms, and their health and vigour constantly change over time. They are not immune to changes in site conditions, or seasonal variations in the weather. It is a condition of this report that *IFS Associates Inc.* be notified of any changes in tree condition and be provided an opportunity to review or revise the recommendations within this report.

Recognition of changes to a tree's condition requires expertise and extensive experience. It is recommended that *IFS Associates Inc.* be employed to re-inspect the tree(s) with sufficient frequency to detect if conditions have changed significantly.

### ASSUMPTIONS

Statements made to *IFS Associates Inc.* in regard to the condition, history and location of the tree(s) are assumed to be correct. Unless indicated otherwise, all trees under investigation in this report are assumed to be on the client's property. A recent survey prepared by a Licensed Ontario Land Surveyor showing all relevant trees, both on and adjacent to the subject property, will be provided prior to the start of field work. The final version of the grading plan for the project will be provided prior to completion of the report. Any further changes to this plan invalidate the report on which it is based. *IFS Associates Inc.* must be provided the opportunity to revise the report in relation to any significant changes to the grading plan. The procurement of said survey and grading plan, and the costs associated with them both, are the responsibility of the client, not *IFS Associates Inc.*

### LIABILITY

Without limiting the foregoing, no liability is assumed by *IFS Associates Inc.* for:

- 1) Any legal description provided with respect to the property;
- 2) Issues of title and/or ownership with respect to the property;
- 3) The accuracy of the property line locations or boundaries with respect to the property;
- 4) The accuracy of any other information provided by the client or third parties;
- 5) Any consequential loss, injury or damages suffered by the client or any third parties, including but not limited to replacement costs, loss of use, earnings and business interruption; and,
- 6) The unauthorized distribution of the report.

Further, under no circumstances may any claims be initiated or commenced by the client against *IFS Associates Inc.* or any of its directors, officers, employees, contractors, agents or assessors, in contract or in tort, more than 12 months after the date of this report.

### ONGOING SERVICES

*IFS Associates Inc.* accepts no responsibility for the implementation of any or all parts of the report, unless specifically requested to supervise the implementation or examine the results of activities recommended herein. If examination or supervision is requested, that request shall be made in writing and the details, including fees, agreed to in advance.

