

Windmill Development Group Ltd.

Site Servicing and Stormwater Management Report

384 Arlington Avenue

City of Ottawa, Ontario



CIMA+ file number: A001272 (370)
October 3rd, 2025 (Rev. 2)

Windmill Development Group Ltd.

Site Servicing and Stormwater Management Report

384 Arlington Avenue
City of Ottawa, Ontario

Prepared by:

Martin Fréchette, P.Eng.
P.E.O. membership number: 100578986

Verified by:



Eric Potvin, P.Eng.
P.E.O. membership number: 100208490



600-1400 Blair Towers Place, Ottawa, ON
Canada K1J 9B8

CIMA+ file number: A001272 (370)
October 3rd, 2025

Table of Contents

1.	Introduction	1
1.1	Site Description and Proposed Development	1
1.2	Review of Available Background Documentation	2
1.3	Existing Infrastructure.....	3
1.4	Consultation and Permits	3
2.	Water Servicing	4
2.1	Water Supply Design Criteria	4
2.2	Proposed Water Supply Servicing and Calculations	5
2.3	Water Supply Summary and Conclusions	8
3.	Sanitary Servicing	8
3.1	Sanitary Servicing Design Criteria	8
3.2	Proposed Sanitary Servicing and Calculations	9
3.3	Sanitary Servicing Summary and Conclusions	10
4.	Storm Servicing and Stormwater Management	10
4.1	Background	10
4.2	Storm Servicing Strategy and Design Criteria.....	11
4.3	Proposed Storm Servicing and Stormwater Management Design and Calculations	11
4.4	Storm Servicing and Stormwater Management Summary and Conclusions	13
5.	Conclusion	14

List of Tables

Table 2-1: Water Supply Design Criteria	4
Table 2-2: Water Demands	5
Table 2-3: Hydrant Coverage Summary	7
Table 2-4: Watermain Boundary Conditions.....	7
Table 2-5: Water Supply Adequacy - Hydraulic Analysis – Arlington Connection	8
Table 3-1: Sanitary Peak Flow Determination Design Criteria.....	9
Table 3-2: Peak Sanitary Flows	9
Table 4-1: Pre-Development Peak Release Flows – Existing Site	10
Table 4-2: Pre-development (Allowable) Release Rate (2-year event).....	12
Table 4-3: Release Rate Summary - Unattenuated Areas - Pre Vs Post-Development.....	12
Table 4-4: Post-development Flow Rate and Storage Summary	13

List of Figures

Figure 1: Site Location - Plan View.	1
Figure 2: Conceptual Site Plan.	2

List of Appendices

Appendix A Pre-consultation Correspondence	
Appendix B Existing Conditions Plan	
Appendix C Detailed Design Civil Plans	
Appendix D Water Supply Design Calculations	
Appendix E Sanitary Servicing Design Calculations	
Appendix F Storm Servicing and Stormwater Management Calculations	
Appendix G Blue-green roof design	

1. Introduction

CIMA+ was retained by Windmill Development Group Ltd. to prepare SITE SERVICING AND SWM REPORT for the proposed construction of a 24-storey residential (ground floor amenity space and 296 residential units) building located at 384 Arlington Avenue in Ottawa, Ontario.

The purpose of this report is to confirm that the proposed development can be adequately serviced by the existing municipal infrastructure (water and sewer) surrounding the site. This report shall be used in support of a Site Plan Control application for a multi-use development.

1.1 Site Description and Proposed Development

The site is located along the north side of the Queensway near Bronson Avenue (refer to **Figure 1** below). 384 Arlington Avenue is currently owned and occupied by the Ottawa Korean Church. The site area (384 Arlington Avenue) measures approximately 0.213 ha.

Generally, the site is bounded by Arlington Ave to the North, Bell Street N. to the West, Arthur Lane N. to the East and Raymond Street to the South.



Figure 1: Site Location - Plan View.

The proposed development is a 24-storey, residential tower with 296 residential units, expected to include approximately 492 residents, and three (3) underground parking levels comprising the entire site area. The total communal amenity space (Activity room, Common Area, Gym, Lobby and Yoga) measures approximately 942 m² on the 3rd, 4th and 7th floors. The total private amenities/Balconies measure approximately 1179 m². Refer to **Figure 2** for a conceptual site plan of the proposed development (prepared by NEUF architect(e)s + FOTENN + WINDMILL).

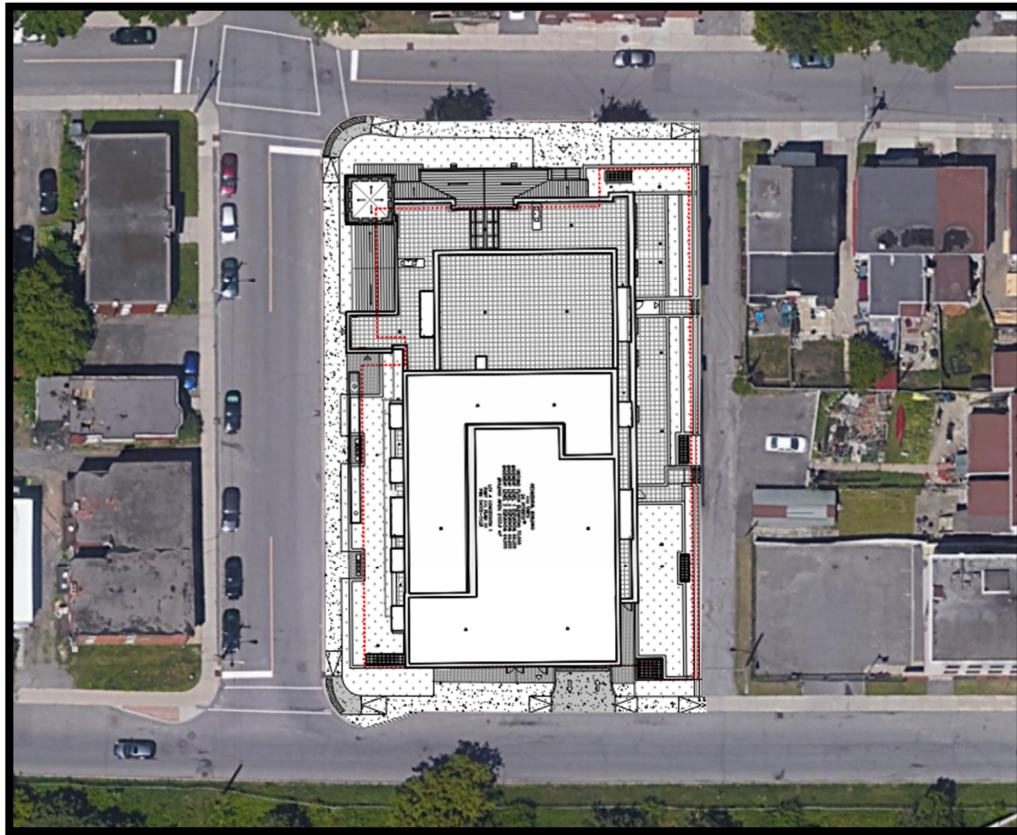

Figure 2: Conceptual Site Plan.

1.2 Review of Available Background Documentation

The following design guidelines have been used to estimate the theoretical servicing requirements for the proposed development, while geoOttawa and the available utility drawings provided by the City of Ottawa Information Centre have been used to determine the existing municipal services fronting the site. Refer to **Appendix A** for available utility plans provided by the City.

- + Ottawa Sewer Design Guidelines (October 2012), including
 - Technical Bulletins ISTB-2018-01.
- + Ottawa Design Guidelines – Water Distribution (2010), including
 - Technical Bulletins ISTB-2021-03, ISTB-2018-02, ISDTB-2014-02 and ISD 2010-02.
- + Ministry of the Environment Design Guidelines for Sewage Works (2008).
- + Ministry of the Environment Stormwater Management Planning and Design Manual (2003).
- + Ministry of the Environment Design Guidelines for Drinking-Water Systems (2008); and
- + Fire Underwriters Survey (FUS) Water Supply for Public Fire Protection (2020).

1.3 Existing Infrastructure

As identified using geoOttawa and the available Utility Record Drawings provided by the City of Ottawa Information Centre, the following municipal infrastructure is available within the right-of-way fronting the proposed development site (refer to **Appendix B** for Existing Conditions Plan).

Arlington Avenue

- + 203 mm diameter PVC watermain installed 2003 (**primary and secondary water connection point**).
- + 300 mm diameter PVC combined sewer (**sanitary connection point**).

Bell Street North

- + 152 mm diameter PVC watermain.
- + 300 mm diameter PVC combined sewer (**storm primary connection point**).

1.4 Consultation and Permits

In response to the pre-consultation requirements defined in the City's Development Servicing Study Checklist, the following agencies were consulted in support of the preparation of this report. The Development Servicing Study Checklist as well as all relevant correspondence with the consulted agencies can be found in **Appendix A**.

City of Ottawa

The City of Ottawa Information Centre was contacted by Stantec to obtain any Reports, Studies, Engineering, and/or Utility Plans including sanitary sewer, storm sewer, watermain, gas, etc. within or adjacent to the site location. The available engineering plans and utility plans were provided and can be found in **Appendix B**.

CIMA+ also contacted Mohammed Fawzi from the City of Ottawa's Planning, Infrastructure and Economic Development Department to obtain any site-specific servicing and stormwater management design criteria for the proposed development. The provided comments and criteria relevant to the Assessment of SITE SERVICING AND SWM REPORT are referenced within the appropriate sections of this report.

Rideau Valley Conservation Authority (RVCA)

The subject site falls under the jurisdiction of the Rideau Valley Conservation Authority (RVCA). CIMA+ contacted Eric Lalande from the RVCA to identify any Natural Heritage/Hazards features that may impact the development as well as any Storm Water Management Criteria for the site and required approvals/permits. These criteria are addressed in *Section 4* of this Report.

Ministry of the Environment, Conservation and Parks (MECP)

CIMA+ has determined that the proposed development will require an Environmental Compliance Approval (ECA) as the development does not meet the exemption requirements per O.Reg. 525/98, section 3(b), when considering the property will discharge into a combined sewer.

*Note: CIMA+ has initiated the process for obtaining Environmental Compliance Approval (ECA) as required. A pre-consultation was held with Emily Diamond of the MECP on May 15 2024, followed by additional correspondence up to August 21. A summary of our discussions is included in **Appendix A**. The official ECA application will be submitted to the MECP in the coming weeks.*

2. Water Servicing

2.1 Water Supply Design Criteria

The design criteria for determining the water demand requirements for the proposed development follow the parameters outlined in the Ottawa Design Guidelines – Water Distribution (2010) and associated technical bulletins, as well as the MOE Design Guidelines for Drinking-Water Systems (2008). Namely, the following parameters have been used in determining the water demands:

Table 2-1: Water Supply Design Criteria

Design Criterion ¹	Residential Areas	Commercial Areas
Average Day Demand	280 L/capita/day	28,000 L/gross hectare/day
Maximum Daily Demand	3.0 × average daily demand ¹	1.5 × average daily demand
Maximum (Peak) Hour Demand	4.5 × average daily demand ¹	1.8 × maximum daily demand
Populations – 1 Bedroom Apartment	1.4 Persons Per Unit	N/A
Populations – 2 Bedroom Apartment	2.1 Persons Per Unit	N/A
Populations – 3 Bedroom Apartment	3.1 Persons Per Unit	N/A
Desired Operating Pressure under Normal Operating Conditions	50 to 70 psi	
Minimum Operating Pressure under Normal Operating Conditions	40 psi	
Maximum Operating Pressure under Normal Operating Conditions	80 psi	
Minimum Operating Pressure under Maximum Daily Demand + Fire Flow	20 psi	

In addition to those design criteria identified in **Table 2-1**, the following comments and criteria identified by the City as part of the pre-consultation must be considered in the water supply servicing strategy:

- + The subject site is located within the 1W pressure zone.

¹ Note that residential peaking factors were selected from **Table 3-3** of the MECP Design Guidelines for Drinking-Water Systems for 0 to 500 persons.

- + Residential buildings with a basic day demand greater than 50 m³/day (0.57 L/s) are required to be connected to a minimum of two (2) water services separated by an isolation valve to avoid a vulnerable service area.
- + Fire flow demand requirements shall be based on the Fire Underwriters Survey (FUS) Water Supply for Public Fire Protection 2020 and Technical Bulletins ISTB-2018-02.
 A primary fire hydrant is required to be within 45 m of the Siamese connection and within 90 m (travel path not radius) of the front door of each building as per OBC and Ottawa Fire Services requirements.
- + Exposure separation distances shall be defined on a figure to support the FUS calculation and required fire flow (RFF).
- + Hydrant capacity shall be assessed if relying on any public hydrants to provide fire protection, particularly if high design fire flows are being proposed, to demonstrate the Required Fire Flow (RFF) can be achieved. Identification of which hydrants are being considered to meet the RFF on a fire hydrant coverage figure is required as part of the boundary conditions request.

2.2 Proposed Water Supply Servicing and Calculations

Water Demands

The water supply demands for the proposed development are presented in **Table 2-2** below. The demands were developed utilizing the development statistics (i.e., residential units and commercial floor area) provided by NEUF architect(e)s + FOTENN + WINDMILL and those design criteria identified in *Section 2.1*. Refer to **Appendix D** for detailed calculations.

Table 2-2: Water Demands

Demand Type	Average Daily Demand (L/s)	Maximum Daily Demand (L/s)	Maximum (Peak) Hour Demand (L/s)
Residential	1.594	4.783	7.175
Commercial	0.031	0.046	0.082
Total	1.62	4.83	7.26

Given the basic day demand exceeds 50 m³/day (or 0.57 L/s) a minimum of two (2) water service connections, separated by an isolation valve, are required to provide redundant supply, and avoid a vulnerable service area.

Proposed Water Supply Connection Point(s)

In order to provide redundancy, a primary and a secondary water service connection separated by a new isolation valve are proposed on Arlington Avenue. Refer to **Appendix C** for the proposed connection points.

Given that the watermain connection on the west side is within 2.4m of an existing catch basin (i.e. ±1.0m), the portion of the watermain within proximity to the catch basin will be insulated as per City of Ottawa W23 detail.

Primary Hydrant and Siamese Location

The Fire Department (Siamese) Connection is proposed at the northwest corner of the building. The nearest hydrant is located just west of the intersection of Arlington Avenue and Bell Street on the south side of Arlington Avenue, approximately 35 m from the proposed Siamese location and well within 90 m of the front door. Refer to **Appendix D** (Figure 2 – Hydrant Coverage) for location of existing hydrant.

Required Fire Flow (RFF)

The required fire flow for the site was developed using the Fire Underwriters Survey (FUS) Water Supply for Public Fire Protection 2020 and associated City of Ottawa Technical Bulletins.

Due to the recently updated FUS Water Supply for Public Fire Protection document, the City has updated their acceptance criteria for a construction coefficient (C) of 0.6, which has been used for RFF calculations for similar buildings according to the 1999 FUS document. Following a City internal meeting, there was a consensus that, to accept a C value of 0.6, the developer's structural engineer and architect would have to provide verification and sign-off to confirm that the building was designed with all structural elements, walls, arches, floors, and roofs with a minimum two (2) hour fire resistance rating, and all materials used in the construction of the structural elements, walls, arches, floors, and roofs are constructed with noncombustible materials. If these criteria cannot be met or verified at the planning stage, a C value of 0.8 shall be used in all RFF calculations submitted to the City for boundary condition request and hydrant coverage confirmation.

As a result of this decision, for the purposes of this project, CIMA+ had originally provided the RFF assuming a C value of 0.6 and a C value of 0.8 such that a range of RFF could be preliminary assessed. However, the architect recently confirmed that C value of 0.8 is to be used for the RFF calculations. The results are as follows:

- + For a C value of 0.8, it was determined that an RFF of **12,000 L/min (200.00 L/s)** would be required to provide adequate protection.

It was assumed that multiple municipal hydrants would be required to meet the fire flow requirements, and a fire hydrant coverage figure was prepared in support of the boundary conditions request from the City.

From the hydrant coverage plan it was confirmed that the aggregate flow of hydrants in the area would be sufficient to meet the required fire flow demands for each scenario. Maximum flow to be considered from each hydrant has been determined in accordance with City of Ottawa Technical Bulletin IST-2018-02 Appendix I Table 1. Refer to **Table 2-3** below for a summary of hydrants considered as well as the individual and aggregate flow of the contributing hydrants.

Table 2-3: Hydrant Coverage Summary

Hydrant No./Location	Hydrant Class	Distance to Building (m)	Contributing Flow (L/min)
1 (Arlington at Bell)	AA	< 75	5,700
2 (Raymond at Bell)	AA	< 75	5,700
3 (Cambridge and Arlington)	AA	> 75 and ≤ 150	3,800
4 (Bell at Louisa)	AA	> 75 and ≤ 150	3,800
Total Contributing Flow (L/min)			19,000

Refer to **Appendix D** for detailed calculations, including supporting figures for exposure distances and hydrant coverage.

Municipal Boundary Conditions

Using the proposed demands and the required fire flow, along with supporting figures, the City provided boundary conditions for hydraulic analysis of current conditions based on computer model simulations. The boundary conditions are as follows:

Table 2-4: Watermain Boundary Conditions

Hydraulic Condition (HGL = Hydraulic Grade Line)	Boundary Condition (Head) (m)
	Arlington Avenue 203 mm dia.
Minimum HGL	107.0
Maximum HGL	115.2
Maximum Day + Fire Flow (C=0.8)	103.7

Note: The Required Fire Flow (RFF) values displayed in the previous section are slightly lower than those provided in the SPC #3 submission from June 6, 2024. Despite this minor discrepancy, it is assumed that the provided Boundary Conditions will still be applicable, as the decrease in RFF is not significant enough to affect the system's ability to meet fire protection requirements (i.e. reduced from 233.33 L/s to 200.00 L/s).

Hydraulic Analysis – Water Supply Adequacy

A hydraulic analysis was completed utilizing the boundary condition information provided by the City for the proposed development to confirm that there is adequate flow and pressure in the water distribution system to meet the required water demands. The following Tables summarize the available flow and pressure in the system under each demand scenario:

Table 2-5: Water Supply Adequacy - Hydraulic Analysis – Arlington Connection

Demand Type	Proposed Demand (L/s)	Available Flow/Pressure		Desired Flow/Pressure Objective	Flow/Pressure Objective Achieved?
		Design Operating Pressure (Relative Head) (m)	Design Operating Pressure (psi)		
Average Daily Demand	1.62	43.4	61.7	50 to 70 psi	Yes
Maximum Day + Fire Flow (C=0.8)	204.83	31.9	45.4	≥ 20 psi	Yes
Maximum (Peak) Hour Demand	7.26	35.2	50.1	50 to 70 psi	Yes
<u>NOTES:</u>					
1. Boundary conditions at connections with a ground elevation of 71.8 m.					

2.3 Water Supply Summary and Conclusions

The water supply design for the proposed development follows the parameters outlined in the Ottawa Design Guidelines – Water Distribution (2010) and associated technical bulletins, as well as the MOE Design Guidelines for Drinking-Water Systems (2008).

There is adequate flow and pressure in the water distribution system to meet the required water demands as well as a sufficient number of contributing hydrants within the area to meet the demands for each fire flow scenario for the proposed development.

3. Sanitary Servicing

3.1 Sanitary Servicing Design Criteria

The design criteria for determining the sanitary peak flow rates for the proposed development follow the parameters outlined in the City of Ottawa Sewer Design Guidelines, 2012 and City of Ottawa Technical Bulletin ISTB-2018-01. Namely, the following parameters have been used in determining the peak sanitary flow rates:

Table 3-1: Sanitary Peak Flow Determination Design Criteria

Design Criterion	Residential Areas	Commercial Areas
Base Flow	280 L/capita/day	28,000 L/gross hectare/day
Populations – 1 Bedroom Apartment	1.4 Persons Per Unit	N/A
Populations – 2 Bedroom Apartment	2.1 Persons Per Unit	N/A
Populations – 3 Bedroom Apartment	3.1 Persons Per Unit	N/A
Peaking Factor	Determined by Harmon Equation $P.F. = 1 + \left[\frac{1}{4 + \left(\frac{P}{1,000}\right)^{\frac{1}{2}}} \right] \times 0.8$ (P = population; P.F. = peaking factor) Maximum P.F. = 4.0 Minimum P.F. = 2.0	1.5 if Commercial Contribution > 20% 1.0 if Commercial Contribution < 20%
Dry Weather Infiltration Rate	0.05 L/s/effective gross hectare (for all areas)	
Wet Weather Infiltration	0.28 L/s/effective gross hectare (for all areas)	
Total Infiltration Allowance	0.33 L/s/effective gross hectare (for all areas)	

3.2 Proposed Sanitary Servicing and Calculations

Proposed Sanitary Peak Flows

The estimated peak flows from the proposed development based on the design criteria listed in **Table 3-1** are outlined in the following Table.

Table 3-2: Peak Sanitary Flows

Flow Type	Total Flow Rate (L/s)
Total Estimated Average Dry Weather Flow Rate	1.62
Total Estimate Peak Dry Weather Flow Rate	5.40
Total Estimate Peak Wet Weather Flow Rate	5.48

Refer to **Appendix E** for detailed calculations.

Proposed Sanitary Service Connection Point

The proposed sanitary service will connect to the existing 300 mm diameter PVC combined sewer within the right-of-way of Arlington Ave. Refer to **Appendix C** for proposed connection points. Considering the mainline sewer is PVC a new maintenance hole will not be required at the point of connection.

Furthermore, a monitoring maintenance hole will be installed on the property.

3.3 Sanitary Servicing Summary and Conclusions

The sanitary servicing design for the proposed development conforms to the requirements of the City of Ottawa Sewer Design Guidelines, 2012, and Technical Bulletin ISTB-2018-01.

Peak wastewater demands were provided to the City, who confirmed that there is adequate residual capacity in the city system to accommodate the proposed wastewater flow (refer to **Appendix A**).

Given the determined peak sanitary flows are quite high, it is expected that self-cleansing velocity will be achieved within the sanitary sewer system and thus a sewer maintenance and flushing program is not required.

4. Storm Servicing and Stormwater Management

4.1 Background

As previously mentioned, the subject site of 384 Arlington Avenue currently occupies the Ottawa Korean Community Church with surface parking. The gradient is from south to north with an approximate change in gradient of 0.7 m across the site. The site is nearly entirely impervious with no existing stormwater measures on site (i.e., catch basins, sewers, etc.) and it is thus assumed that there are no current stormwater management controls on site. As such storm runoff generally sheet flows to the surrounding roadways.

Considering there are no current stormwater systems on site and that it is assumed that there are no flow attenuation controls the anticipated peak flows for the existing site are as follows (refer to **Appendix F**):

Table 4-1: Pre-Development Peak Release Flows – Existing Site

Storm Event	Release Flow (L/s)
2-year	40.96 (with a C=0.90)
100-year	105.80 (with a C=1.00)

4.2 Storm Servicing Strategy and Design Criteria

The design of the major and minor storm systems must ensure that the following criteria are upheld under post-development conditions, in keeping with the requirements of the City and the Rideau Valley Conservation Authority (refer to **Appendix A**).

- + The allowable release rate for the site shall coincide with the 2-year storm event under pre-development conditions.
- + The allowable release rate shall take into consideration any increase in uncontrolled runoff from the boulevard being converted to a hard surface (concrete, interlocking paving stone, etc.).
- + The pre-development runoff coefficient (C) shall be a maximum equivalent 'C' of 0.40, or the actual existing site runoff coefficient, whichever is less.
- + The pre-development Time of Concentration (T_c) shall be calculated using an appropriate method and must not be less than 10 minutes.
- + A T_c of 10 minutes shall be used for all post-development calculations.
- + Storm runoff in excess of the allowable 2-year pre-development release rate, up to and including the 100-year storm event, must be detained on site.
- + Where the underground storage tank/cistern is proposed and calculated utilizing the Modified Rational Method, an average release rate equal to 50% of the peak allowable rate shall be applied to estimate the required volume to account for fluctuating head and release rate.
- + To address concerns about roadway drainage spilling into the underground parking, the entrance to the underground parking will be equipped with a trench drain that will redirect the stormwater in the underground cistern that will pump the stormwater into the combined sewer in Bell Street.
- + Foundation drains will be pumped into the proposed cistern with appropriate back up power, sufficient sized pump, and backflow prevention thus negating the need for a second storm connection to the combine sewer main in Bell Street.
- + The roof drain leaders will be utilizing a pressurized drainpipe type to provide additional protection in the event of surcharge in the municipal system.
- + Considering the site will connect to the municipal combined sewer system, no long-term surface parking spots are being proposed and rainwater from landscaping and rooftop drainage is considered to be clean for the purpose of protecting water quality and aquatic habitat, the RVCA would not require any onsite water quality control measures save and except best management practices.

4.3 Proposed Storm Servicing and Stormwater Management Design and Calculations

Proposed Storm Service Connection Point

Based on communications with the City, the preferred and anticipated stormwater connection from the proposed development will discharge to the existing 300 mm combined sewer on Bell Street. More precisely, the building stormwater will outlet into the proposed underground cistern that will in turn be pumped into the Bell Street combined sewer via a PVC DR-35 200Ø service lateral as well as an emergency overflow that will spill onto Bell Street. Refer to **Appendix C** for proposed connection points.

- + The underground cistern access holes will act as a monitoring maintenance hole.
- + Considering the mainline sewer is made of PVC, a new maintenance hole will not be required at the point of connection.

Pre-development (Allowable) Release Rates

For this sector, the City requires that the storm runoff under post-development conditions for the site area must be controlled to the 2-year pre-development release rate of **18.2 L/s**, up to and including the 100-year storm event. This release rate was determined using a runoff coefficient of 0.4 (the actual existing site runoff coefficient being 0.90). This overdesign was requested by the City due to concerns about the capacity of the receiving combined sewer.

The pre-development release rates are summarized in the following Table:

Table 4-2: Pre-development (Allowable) Release Rate (2-year event)

Catchment ID	Area (ha)	Runoff Coefficient (C)	Time of Concentration (Tc) (minutes)	Rainfall Intensity (mm/hr)	Release Rate (L/s)
Subject Site	0.213	0.40	10	76.81	18.2

Post Development Flow Rates and Stormwater Quantity Control

As indicated above, the existing site has no current stormwater management controls and primarily consists of impermeable surfaces. The proposed development brings additional efforts towards improving the existing unattenuated areas. Table 4-3 below provides a comparison between pre-development and post-development conditions for these areas.

Table 4-3: Release Rate Summary - Unattenuated Areas - Pre Vs Post-Development

Design Event	Area (ha)	Runoff Coefficient (C)	Weighted Runoff Coefficient (C)	100-year Release Rate (L/s)	100-year Release Flow Per Unit Area (L/s/ha)
Pre-development (NC1)	0.0264	0.90	1.00	13.0	496.00
Post-development (NC1)	0.0264	0.79	0.98	12.8	486.08
Variance (Post minus Pre)				-0.3	-9.92

Since significant improvements have been incorporated into the proposed development, and the unattenuated comparison indicates a slight enhancement over the existing conditions by replacing impermeable surfaces with permeable ones, the uncontrolled flow was not considered within the 18.2 L/s allowable release rate, as shown in Table 4-2 above. Please refer to Appendix A for the City's confirmation. Refer to **Appendix A** for city confirmation.

- + The anticipated post-development flow rates and required storage when controlled to the allowable pre-development release rate are summarized in the following Table. Additionally, as requested, the required underground storage volume was calculated using 50% of the peak allowable release rate to account for fluctuating head and release rate.

Table 4-4: Post-development Flow Rate and Storage Summary

Control Area	100-year Release Rate – NO PUMP (L/s)	100-year Storage Volume – NO PUMP (m ³)
Building Roof Drains, Surface Drains, Trench Drain, and Foundation Drain to Underground Cistern	18.2	72 (for a 9.1 L/s release rate)
Total	18.2	72

As demonstrated in **Table 4-3**, an anticipated storage volume of **72 m³** would be required on-site. This will be achieved with an underground storage cistern to restrict stormwater discharge to the allowable release rate of **18.2 L/s**. Refer to **Appendix F** for detailed stormwater storage calculations.

The underground cistern's storage volume is currently anticipated at **72 m³**. This volume is dependent on the following factors:

- + Cistern details and information including detailed cross-section, exact dimensions, etc.
- + Blue-green roof design will be implemented on levels 4 and 7. See architectural roof drawings as well as the landscaping drawings for the locations of the blue-green roofs, and refer to **APPENDIX G** for ZinCo Canada's blue-green roof design information. The blue-green roof system will retain water; however, it is anticipated that the system will be often full or partially full at the beginning of rainfall events. For this reason, the volume of the proposed underground stormwater cistern will not be reduced to account for any stormwater volume that may be stored in the blue-green roof system.

At this time, a backflow check valve is proposed to be added to the 200 mm diameter outlet of the stormwater cistern to protect it in the event that the 300 mm diameter combined sewer main in Bell Street becomes surcharged.

Stormwater from landscaping and rooftop drainage is considered to be clean for the purpose of protecting water quality and aquatic habitat.

Through consultation with the Rideau Valley Conservation Authority (RVCA) (refer to **Appendix A**) it was confirmed that they would not require any additional onsite water quality control measures save and except best management practices.

4.4 Storm Servicing and Stormwater Management Summary and Conclusions

The storm servicing design for the proposed development conforms to the requirements of the City of Ottawa Sewer Design Guidelines, 2012, and associated Technical Bulletins.

The proposed discharge to the storm sewer was provided to the City, who confirmed that there is adequate capacity in the city system to accommodate the proposed flow (refer to **Appendix A**).

An anticipated on-site storage volume of **72 m³** would be achieved via an underground storage cistern to restrict stormwater discharge to the allowable release rate of **18.2 L/s**.

Roof Flow Control Declaration will be provided upon completion of the Mechanical and Structural design.

5. Conclusion

The purpose of this assessment is to confirm that the proposed development can be adequately serviced using the existing municipal infrastructure (water, sanitary and storm) surrounding the site. This report shall be used in support of a Site Plan Control (SPC) to allow for the construction of one (1) 24-storey residential tower with ground floor amenity space.

The important information and findings as a result of this assessment are as follows:

- + The proposed residential building is expected to include 296 apartment units with a population of approximately 492 persons and have a total communal amenity area of approximately 942 m² and a total private amenities/Balconies of approximately 1179 m². There will be three (3) levels of underground parking spanning the entirety of the site area.
- + The required Environmental Compliance Approval (ECA) application was initiated in relation to O.Reg. 525/98, section 3(c).
- + The anticipated water demands for the proposed site are **1.62 L/s** (average day), **204.83 L/s** (max day + fire flow), and **7.26 L/s** (peak hour). The boundary conditions received from the City of Ottawa indicate that the existing watermain network can provide the required water demands for the proposed site. From the hydrant coverage plan it was confirmed that the aggregate flow of hydrants in the area would be sufficient to meet the required fire flow demands for each scenario.
- + The estimated sanitary flow for the proposed development is **1.62 L/s** (average dry weather), **5.40 L/s** (peak dry weather), and **5.48 L/s** (peak wet weather). The City of Ottawa has indicated that the existing sanitary sewer network near the proposed site can accept the peak wet weather sanitary flow of the proposed development.
- + Storm runoff in excess of the allowable 2-year pre-development release rate, up to and including the 100-year storm event, will be detained on site via an internal cistern prior to being discharged to the municipal combined sewer system.
- + The allowable stormwater release rate for the proposed site is **18.2 L/s**. It is expected that this will be achieved by means of underground retention (cistern). To achieve this release rate, a total storage volume of **72 m³** is required on-site. The City of Ottawa has indicated that they have no issue with the proposed discharge rate.
- + The existing site is nearly entirely impervious with no existing stormwater measures on site (i.e., catch basins, sewers, etc.) and it is assumed that there are no current stormwater management controls on site. Thus, stormwater flows from the redeveloped site are to be considerably less than the stormwater flows from the existing site.
- + Quality control of stormwater is not required for the site given rainwater from landscaping and rooftop drainage is considered to be clean for the purpose of protecting water quality and aquatic habitat. Furthermore, the discharge point will rely on municipal infrastructure considering the connection to the combined sewer system.
- + As a result of the conclusions drawn by the previous points, it is expected that the proposed development can be serviced by the existing municipal services network surrounding the site.

We trust this Site Servicing and Stormwater Management Report is to your satisfaction. If you have any questions regarding this report, please do not hesitate to contact any of the signatories.

A

Appendix A Pre-consultation Correspondence

Appendix A

1A - WATER DEMANDS BOUNDARY CONDITIONS

Éric Potvin

De: Whelan, Amy <amy.whelan@ottawa.ca>
Envoyé: 27 mai 2024 14:40
À: Éric Potvin
Cc: Jessica.bellissimo@windmilldevelopments.com;
kristen.jorgensen@windmilldevelopments.com; Pardis Parsa; Martin Fréchette
Objet: RE: 384 Arlington Avenue
Pièces jointes: 384 Arlington Avenue REVISED May 2024.pdf

EXTERNAL EMAIL

Hi Eric,

Literally just received this from drinking water services five minutes ago.

******The following information may be passed on to the consultant, but do NOT forward this e-mail directly.******

The following are boundary conditions, HGL, for hydraulic analysis at 384 Arlington Avenue (zone 1W) assumed to be a dual connection connected to the 203mm watermain on Arlington Avenue (see attached PDF for location).

Minimum HGL: 107.0 m

Maximum HGL: 115.2 m

Max Day+ Fire Flow (100.00 L/s): 108.6 m

Max Day+ Fire Flow (233.33 L/s): 103.7 m

These are for current conditions and are based on computer model simulation.

Disclaimer: The boundary condition information is based on current operation of the city water distribution system. The computer model simulation is based on the best information available at the time. The operation of the water distribution system can change on a regular basis, resulting in a variation in boundary conditions. The physical properties of watermains deteriorate over time, as such must be assumed in the absence of actual field test data. The variation in physical watermain properties can therefore alter the results of the computer model simulation.

Kind regards,

Amy Whelan, E.I.T
Project Manager, Infrastructure Approvals

Boundary Conditions for 384 Arlington Avenue

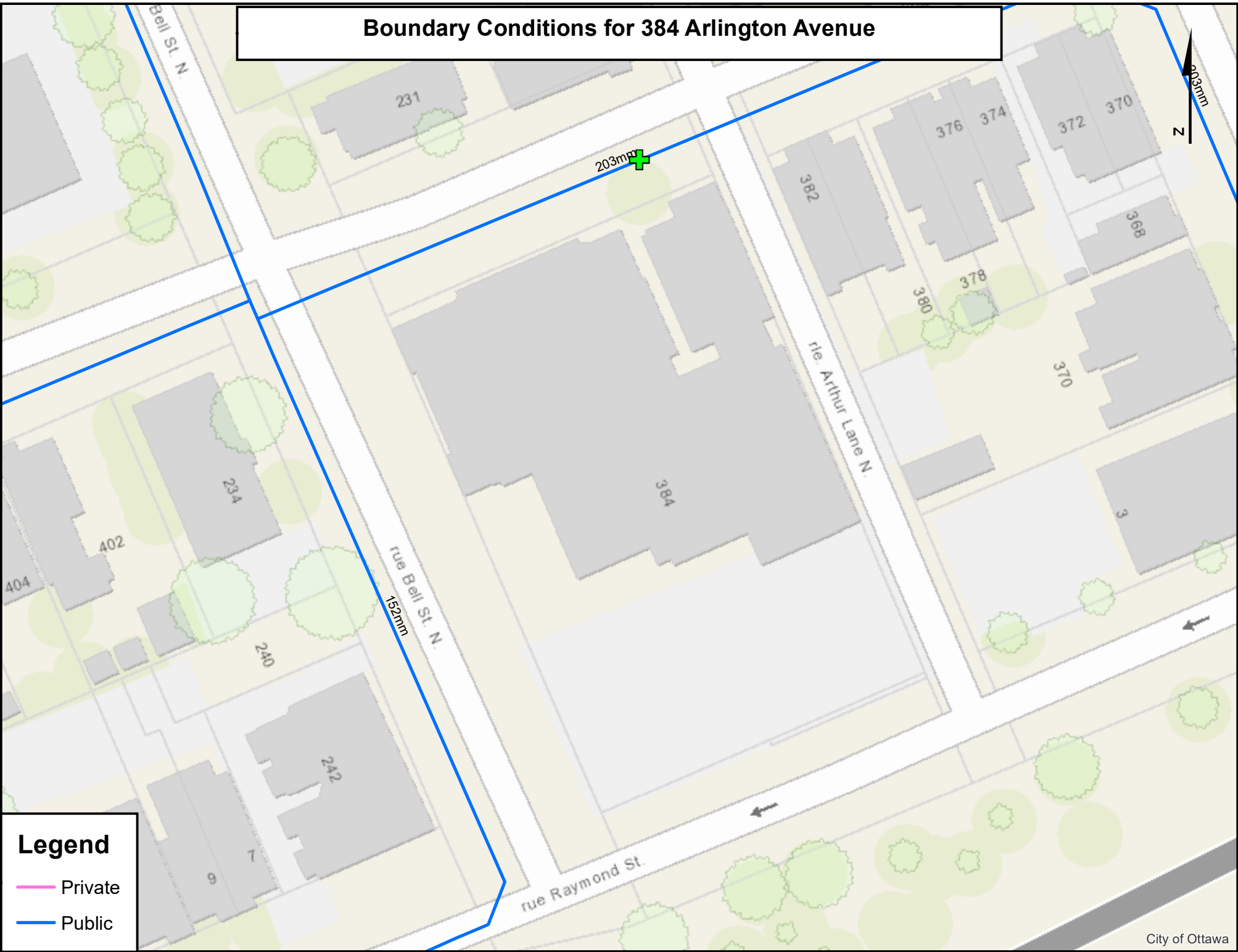

Legend

- Private
- Public

Éric Potvin

De: Éric Potvin
Envoyé: 25 avril 2024 17:29
À: Fawzi, Mohammed
Cc: Pardis Parsa
Objet: RE: 384 Arlington Av. - Water Demands - Boundary Condition Request
Pièces jointes: 6_230310_Figure 3 - Hydrant Coverage.pdf; 1_240425_Water Demands.pdf; 2_240425_Fire Flow (C=0.6).pdf; 3_240425_Fire Flow (C=0.8).pdf; 5_220728_Figure 2 - Exposure Separation Distances.pdf; 240425_preferred connection sketch.pdf

Hello Mohammed,

As a follow-up to my colleague Jameson's coordination below regarding the proposed conversion development at 384 Arlington Avenue, we are preparing to submit a revised Adequacy of Serving report for the SPC Phase 3, the proposed building statistics (area and number of residential units) have changed slightly. We would like to kindly request updated boundary conditions. Please find the proposed development information below, along with our detailed calculations and associated figures attached. These include Water Demand Calculations, Fire Flow Calculations (coefficient = 0.8 and 0.6), Location of Service (Figure 1), Exposure Separation Distances (Figure 2), Fire Hydrant Coverage (Coefficient = 0.8, Figure 3), and the Architectural Site Plan for reference.

1. Type of Development and Units: The proposed development involves the construction of one (1) 24-storey mixed-use building (residential and commercial space). There are a total of **297 residential units** with an underground 3-level parking garage.
2. Site Address: 384 Arlington Avenue
3. Location of Services: Two connections to existing 203mmØ PVC municipal watermain in Arlington Avenue. The primary and redundancy services would be separated by a new isolation valve on the municipal main.
4. Average Daily Demand: 1.68 L/s
5. Maximum Daily Demand: 4.99 L/s
6. Peak Hour Demand: 7.50 L/s
7. Required Fire Flow (RFF) (C = 0.8): 14,000 L/min
8. Required Fire Flow (RFF) (C = 0.6): 6,000 L/min

If you have any questions or concerns, please do not hesitate to contact me. Would you also be able to confirm receipt of this request for wastewater capacity confirmation?

Best Regards,

ERIC POTVIN, P.Eng., ing. (PEO, OIQ, APEY)
Project Manager / Infrastructure
Chargé de projet / Infrastructures

M 613-863-7340 F 613-860-1870
600-1400 Blair Towers Place, Ottawa, ON K1J 9B8 CANADA



Engineering
for people



KINCENTRIC
Best Employer
CANADA 2021

Follow us / Suivez-nous



Appendix A

1B - FIRE FLOW HYPOTHESES BACKUP FROM ARCHITECT

From: [Antoine Cousineau](#)
To: [Jaymeson Adams](#); [Hugues Bisson](#); [Kristen Jorgensen](#)
Cc: [Samuel Pouliot](#); [Stephen Savell](#); [Tim Kennedy](#)
Subject: RE: A001272 - Redevelopment 384 Arlington - Civil Design Questions and Considerations
Date: Friday, July 15, 2022 7:50:03 AM

EXTERNAL EMAIL

Jaymeson
See my comments in blue bellow within the yellow section

A



ANTOINE COUSINEAU OAA, OAA, AAA, NCARB, IRAC, LEED, AP
Architecte associé . Partner architect
T 514 847 1117 #250 F 514 847 2287 C 514 515 2048
630, boul. René-Lévesque O. 32^e étage, Montréal (QC) H3B 1S6
NEUF ARCHITECTES INC [Confidentialité + Transmission](#)
Montréal. Ottawa. Toronto

50 ANS ET TOUJOURS NEUF . 50 YEARS AND STILL NEUF

De : Jaymeson Adams <Jaymeson.Adams@cima.ca>
Envoyé : 13 juillet 2022 14:18
À : Hugues Bisson <Hugues.Bisson@cima.ca>; Kristen Jorgensen <kristen.jorgensen@windmilldevelopments.com>; Antoine Cousineau <antoine@neufarchitectes.com>
Cc : Samuel Pouliot <spouliot@neufarchitectes.com>; Stephen Savell <Stephen.Savell@windmilldevelopments.com>; Tim Kennedy <Tim.Kennedy@cima.ca>
Objet : RE: A001272 - Redevelopment 384 Arlington - Civil Design Questions and Considerations

Avertissement: Il s'agit d'un e-mail externe dont l'objet ou le contenu est suspect. Soyez prudent lorsque vous cliquez sur des liens ou ouvrez des pièces jointes. En cas de doute, contactez le support informatique à it@neufarchitectes.com.

Caution: This is an external email and has a suspicious subject or content. Please take care when clicking links or opening attachments. When in doubt, contact your IT Department at it@neufarchitectes.com.

Bonjour Antoine,

Please see, in the email string below, what we would like to confirm for our fire flow calculations (in yellow highlight).

Merci,

Upcoming vacation notice: 14 to 22 July 2022

JAYMESON ADAMS, P.Eng.
Engineer / Infrastructure
Ingénieur / Infrastructures

+ Water and Fire Protection Considerations and Questions:

- o For required fire flow determination (RFF) we will assume the building will be constructed of either Noncombustible Construction or Fire Resistive Construction as follows:
 - Fire Resistive Construction: where all structural elements, walls, arches, floors, and roofs are constructed with a minimum 2-hour fire resistance rating and all materials used in the construction of the structural elements, walls, arches, floors, and roofs are constructed with noncombustible materials. [Antoine Cousineau] Building will be non combustible with 2h fire- resistance for structural, floors walls and exits
 - Fire Resistive Construction also assumes all vertical openings and exterior vertical communications (ex. Interconnected floor spaces, atria, elevators, escalators, etc.) are properly **protected** in accordance with the National Building Code (NBC). That is (i.) Enclosures have walls of masonry or other limited or noncombustible construction with a fire resistance rating of not less than one hour, (ii.) openings including doors shall be protected with automatic closing devices and (iii.) elevator doors shall be of metal or metal-covered construction, so arranged that the doors must normally be closed for operation of the elevator.
 - Noncombustible Construction: where all structural elements, walls, arches, floors, and roofs are constructed with a minimum 1-hour fire resistance rating and are constructed with noncombustible materials. [Antoine Cousineau] OK, see above
 - Noncombustible Construction assumes any vertical openings in the building are **unprotected**. That is any opening through horizontal separations that are unprotected or otherwise have closures that do not meet the minimum requirements for protected openings, above.
- o We will assume the building is sprinklered, but system **not fully supervised** (i.e., continuously monitored). For a fully supervised system a supervisory signal is required to ensure that malfunctions of the automatic sprinkler system will be discovered and corrected promptly, while a water flow alarm is required to notify emergency services of the fire as soon as the automatic sprinkler system activates. Some additional information as follows: [Antoine Cousineau] building is a high rise and will be fully sprinklered, supervised and connected to firestation
 - The supervisory signal is to sound and be displayed, either at a location within the building that is constantly attended by qualified personnel (such as a security room), or at an approved remotely located receiving facility (such as a monitoring facility of the sprinkler system manufacturer); and
 - The water flow alarm must indicate that the sprinkler has been activated, which is to be transmitted to an approved, proprietary alarm-receiving facility, a remote station, a central station or the fire department.

Let me know if you want to discuss any of these items and if we should proceed with communicating directly with the client or through you on this one.

Thanks,
Tim

TIM KENNEDY, P.Eng.
Senior Project Manager / Infrastructure

T 613-860-2462 ext. 6620 M 613-462-3627 F 613-860-1870
110-240 Catherine Street, Ottawa, ON K2P 2G8 CANADA



Engineering
for people



KINCENTRIC
Best Employer
CANADA 2021

Appendix A

2A - SANITARY CAPACITY CONFIRMATION

Pardis Parsa

From: Whelan, Amy <amy.whelan@ottawa.ca>
Sent: May 15, 2024 11:18 AM
To: Pardis Parsa; Éric Potvin
Cc: Jessica.bellissimo@windmilldevelopments.com;
kristen.jorgensen@windmilldevelopments.com
Subject: RE: 384 Arlington Avenue

EXTERNAL EMAIL

Good morning Pardis,

I have not received a response from the water department regarding the boundary condition request however I just followed up with them. Typically the wait time for this request is about ten business days. I will follow up with you as soon as I receive a response.

I did hear back from the modeling group for the combined sewer capacity, please see the response below:

The flow of 5.66 L/s is fine, but this being a combined pipe means that they must control the storm runoff to the 2 year events and the max allowable release rate is based on $C=0.4$

Kind regards,

Amy

From: Pardis Parsa <Pardis.Parsa@cima.ca>
Sent: May 15, 2024 10:44 AM
To: Whelan, Amy <amy.whelan@ottawa.ca>; Éric Potvin <Eric.Potvin@cima.ca>
Cc: Jessica.bellissimo@windmilldevelopments.com; kristen.jorgensen@windmilldevelopments.com
Subject: RE: 384 Arlington Avenue

CAUTION: This email originated from an External Sender. Please do not click links or open attachments unless you recognize the source.

ATTENTION : Ce courriel provient d'un expéditeur externe. Ne cliquez sur aucun lien et n'ouvrez pas de pièce jointe, excepté si vous connaissez l'expéditeur.

Hi Amy,

I'm following up on the water boundary condition and combined sewer capacity requests. We haven't received the information yet and were wondering if there are any updates.

Could you possibly provide an estimate of when we might expect a response?

Best regards,

De : Fawzi, Mohammed <mohammed.fawzi@ottawa.ca>

Envoyé : 26 avril 2024 07:40

À : Whelan, Amy <amy.whelan@ottawa.ca>; Éric Potvin <Eric.Potvin@cima.ca>

Cc : Pardis Parsa <Pardis.Parsa@cima.ca>

Objet : RE: 384 Arlington Avenue - Peak Wastewater Demand - Capacity Confirmation

EXTERNAL EMAIL

Hi Éric,

Thank you for your email.

I am copying this email to my colleague Amy (cc'd) as she is looking after this file moving forward.

Thank you.

Best Regards,

Mohammed Fawzi, P.Eng.

Project Manager, Infrastructure - Gestionnaire de projet, Projets d'infrastructure

Development Review All Wards (DRAW) | Direction de l'examen des projets d'aménagement - Tous les quartiers (EPATQ)

Planning, Development and Building Services Department (PDBS) | Direction générale des services de la planification, de l'aménagement et du bâtiment (DGSPAB)

City of Ottawa | Ville d'Ottawa

110 Laurier Avenue West | 110 Avenue Laurier Ouest

Ottawa, ON K1P 1J1

613.580.2424 ext./poste 20120, Mohammed.Fawzi@ottawa.ca

From: Éric Potvin <Eric.Potvin@cima.ca>

Sent: Thursday, April 25, 2024 5:14 PM

To: Fawzi, Mohammed <mohammed.fawzi@ottawa.ca>

Cc: Pardis Parsa <Pardis.Parsa@cima.ca>

Subject: RE: 384 Arlington Avenue - Peak Wastewater Demand - Capacity Confirmation

CAUTION: This email originated from an External Sender. Please do not click links or open attachments unless you recognize the source.

ATTENTION : Ce courriel provient d'un expéditeur externe. Ne cliquez sur aucun lien et n'ouvrez pas de pièce jointe, excepté si vous connaissez l'expéditeur.

Hello Mohammed,

As a follow-up to my colleague Jameson's coordination below regarding the proposed conversion development at 384 Arlington Avenue, we are preparing to submit a revised Adequacy of Serving report for the SPC Phase 3, the proposed building statistics (area and number of residential units) have changed slightly. Please find below an updated summary of the proposed development of information and anticipated sanitary demands. I've also attached our detailed calculations and the Architectural Site Plan for reference.

1. Type of Development and Units: The proposed development involves the construction of one (1) 24-storey mixed-use building (residential and commercial space). There are a total of **297 residential units** with an underground 3-level parking garage.
2. Site Address: 384 Arlington Avenue
3. Location of Services: Proposed sanitary is connecting to the 300mmØ PVC municipal combined sewer main in Arlington Avenue. FYI, the proposed storm would connect to Bell Street North on another 300mmØ PVC combined municipal main sewer.
4. Total Estimated Average Dry Weather Flow: 1.68 L/s
5. Total Estimated Peak Dry Weather Flow: 5.59 L/s
6. Total Estimated Peak Wet Weather Flow: 5.66 L/s

Could you please confirm if there is enough capacity in the City system to accommodate the modified proposed wastewater flow for this lot? Would you also be able to confirm receipt of this request for wastewater capacity confirmation?

Best regards,

ERIC POTVIN, P.Eng., ing. (PEO, OIQ, APEY)
Project Manager / Infrastructure
Chargé de projet / Infrastructures

M 613-863-7340 F 613-860-1870
600–1400 Blair Towers Place, Ottawa, ON K1J 9B8 CANADA



Engineering
for people



Follow us / Suivez-nous



KINCENTRIC
Best Employer
CANADA 2021

De : Fawzi, Mohammed <mohammed.fawzi@ottawa.ca>

Envoyé : 15 juillet 2022 12:12

À : Jaymeson Adams <Jaymeson.Adams@cima.ca>

Cc : Tim Kennedy <Tim.Kennedy@cima.ca>; Gavin Joseph <Gavin.Joseph@cima.ca>

Objet : RE: 384 Arlington Avenue - Peak Wastewater Demand - Capacity Confirmation

EXTERNAL EMAIL

Hi Jaymeson,

This is to confirm there are no capacity concerns.

Appendix A

**2B - SANITARY SERVICE
CONNECTION INSPECTION
CHAMBER**

Éric Potvin

De: Fawzi, Mohammed <mohammed.fawzi@ottawa.ca>
Envoyé: 11 juillet 2022 12:31
À: Jaymeson Adams
Cc: Tim Kennedy; Gavin Joseph
Objet: RE: 384 Arlington Avenue - Peak Wastewater Demand - Capacity Confirmation

EXTERNAL EMAIL

Hi Jaymeson,

Please see my comments in red below.

Best Regards,

Mohammed Fawzi, P.Eng.

Project Manager

Planning, Infrastructure and Economic Development Department - Services de la planification, de l'infrastructure et du développement économique

Development Review - Central Branch

City of Ottawa | Ville d'Ottawa

110 Laurier Avenue West Ottawa, ON | 110, avenue. Laurier Ouest. Ottawa (Ontario) K1P 1J1

613.580.2424 ext./poste 20120, Mohammed.Fawzi@ottawa.ca

****Please note that due to the current situation, I am working remotely. Email is currently the best way to contact me****

From: Jaymeson Adams <Jaymeson.Adams@cima.ca>

Sent: July 06, 2022 5:24 PM

To: Fawzi, Mohammed <mohammed.fawzi@ottawa.ca>

Cc: Tim Kennedy <tim.kennedy@cima.ca>; Gavin Joseph <Gavin.Joseph@cima.ca>

Subject: RE: 384 Arlington Avenue - Peak Wastewater Demand - Capacity Confirmation

CAUTION: This email originated from an External Sender. Please do not click links or open attachments unless you recognize the source.

ATTENTION : Ce courriel provient d'un expéditeur externe. Ne cliquez sur aucun lien et n'ouvrez pas de pièce jointe, excepté si vous connaissez l'expéditeur.

Hi Mohammed,

Regarding the sanitary and storm connections for the below development, I have a couple questions:

1. The proposed building is expected to encompass the entire site area. Therefore, there would not be space to install a monitoring maintenance hole within the property line. To rectify this, we propose to install a wastewater sampling / inspection chamber on the sanitary connection as per City Detail S18.1. Do you agree with this approach? **Agreed.**
2. We assume that there would need to be separate sanitary and storm connections to the combined sewer (see attached sketch for proposed connection points) in case the City installs separate sanitary and storm sewers in the area in the future. This would also require two manholes on the combined sewer, one for each connection. Could you please confirm this approach? We have not had many projects in the past where we have had to connect to a combined sewer, so any information you could provide would be helpful and greatly appreciated. **Looking into this with Asset Management and will get back to you.**

If you would like, I am available for further discussion on these points. Feel free to give me a call on my cell (343-204-5387) or we could organize a Teams meeting.

Thanks,

Upcoming vacation notice: 14 to 22 July 2022

JAYMESON ADAMS, P.Eng.
Engineer / Infrastructure
Ingénieur / Infrastructures



C 343 204-5387  [Contact me on Teams / Contactez-moi sur Teams](#)
110–240 Catherine Street, Ottawa, ON K2P 2G8 CANADA



L'humain au centre
de l'ingénierie



KINCENTRIC
Employeur de choix
CANADA 2021

Suivez-nous / Follow us    

Devez-vous vraiment imprimer ce courriel? Pensons à l'environnement!
Do you really need to print this email? Let's protect the environment!

AVERTISSEMENT CONCERNANT LA CONFIDENTIALITÉ Ce message est confidentiel. S'il ne vous est pas destiné, veuillez en informer l'émetteur immédiatement et le détruire intégralement.

CONFIDENTIALITY WARNING This email is confidential. If you are not the intended recipient, please notify the sender immediately and delete it in its entirety.

Appendix A

3 - SWM - Uncontrolled Drainage Confirmation

From: Hughes, Brett <brett.hughes@ottawa.ca>
Sent: August 15, 2024 10:52 AM
To: Éric Potvin
Cc: Whelan, Amy; Martin Fréchette; Howlader, Nazrul
Subject: FW: 384 Arlington Av. - SPC Phase 3 Civil Comment

EXTERNAL EMAIL

Eric,
Please see response from the City's modelling group. Please advise if you require anything else.

Regards,
Brett Hughes BEng.
Project Manager, Infrastructure
Development Review Central
PLANNING, DEVELOPMENT & BUILDING SERVICES (PDBS)
110 Laurier Ave West | 4th Floor | Ottawa, ON | K1P 1J1
City of Ottawa | Ville d'Ottawa
☎ 613.580.2424 ext./poste 32541

From: Jhamb, Nishant <nishant.jhamb@ottawa.ca>
Sent: August 14, 2024 10:53 AM
To: Hughes, Brett <brett.hughes@ottawa.ca>
Subject: RE: 384 Arlington Av. - SPC Phase 3 Civil Comment

Hello Brett,

Without looking at the plans, I don't see any issues with small uncontrolled area draining to the Row if they are improving existing conditions by reducing the runoff.

Thanks
Nishant

From: Hughes, Brett <brett.hughes@ottawa.ca>
Sent: August 12, 2024 9:57 AM
To: Jhamb, Nishant <nishant.jhamb@ottawa.ca>
Cc: Éric Potvin <Eric.Potvin@cima.ca>; Whelan, Amy <amy.whelan@ottawa.ca>; Martin Fréchette <Martin.Frechette@cima.ca>; Howlader, Nazrul <Nazrul.Howlader@ottawa.ca>
Subject: RE: 384 Arlington Av. - SPC Phase 3 Civil Comment

Nishant,
Please see below for a modelling inquiry received from Eric Potvin last week in Amy's absence (email attached detailing inquiry). Are you able to investigate and provide feedback to the Applicant? Please advise.

Regards,

Brett Hughes BEng.

Project Manager, Infrastructure
Development Review Central
PLANNING, DEVELOPMENT & BUILDING SERVICES (PDBS)
110 Laurier Ave West | 4th Floor | Ottawa, ON | K1P 1J1
City of Ottawa | Ville d'Ottawa
☎ 613.580.2424 ext./poste 32541

From: Éric Potvin <Eric.Potvin@cima.ca>

Sent: August 09, 2024 4:43 PM

To: Hughes, Brett <brett.hughes@ottawa.ca>

Cc: Whelan, Amy <amy.whelan@ottawa.ca>; Martin Fréchette <Martin.Frechette@cima.ca>

Subject: RE: 384 Arlington Av. - SPC Phase 3 Civil Comment

CAUTION: This email originated from an External Sender. Please do not click links or open attachments unless you recognize the source.

ATTENTION : Ce courriel provient d'un expéditeur externe. Ne cliquez sur aucun lien et n'ouvrez pas de pièce jointe, excepté si vous connaissez l'expéditeur.

Hi Brett,

Yes, that's right. It would be appreciated.

Thank you and have a good weekend,

ERIC POTVIN, P.Eng., ing. (PEO, OIQ, APEY)
Project Manager / Infrastructure – Civil
Chargé de projet / Infrastructures – Civil

☎ 613-863-7340 ☎ 613-860-1870
600–1400 Blair Towers Place, Ottawa, ON K1J 9B8 CANADA



Engineering
for people



Follow us / Suivez-nous



De : Hughes, Brett <brett.hughes@ottawa.ca>

Envoyé : 9 août 2024 16:29

À : Éric Potvin <Eric.Potvin@cima.ca>

Cc : Whelan, Amy <amy.whelan@ottawa.ca>; Martin Fréchette <Martin.Frechette@cima.ca>

Objet : RE: 384 Arlington Av. - SPC Phase 3 Civil Comment

EXTERNAL EMAIL

Eric,

Forgive my ignorance, I have zero knowledge about this application. To clarify, you are just looking to connect with a one the City modelers for confirmation? Please confirm.

If my interpretation is accurate, I will be track down a contact for you early next week to assist with your inquiry.

Regards,

Brett Hughes BEng.

Project Manager, Infrastructure

Development Review Central

PLANNING, DEVELOPMENT & BUILDING SERVICES (PDBS)

110 Laurier Ave West | 4th Floor | Ottawa, ON | K1P 1J1

City of Ottawa | Ville d'Ottawa

☎ 613.580.2424 ext./poste 32541

From: Éric Potvin <Eric.Potvin@cima.ca>

Sent: August 08, 2024 9:58 AM

To: Hughes, Brett <brett.hughes@ottawa.ca>

Cc: Whelan, Amy <amy.whelan@ottawa.ca>; Martin Fréchette <Martin.Frechette@cima.ca>

Subject: RE: 384 Arlington Av. - SPC Phase 3 Civil Comment

CAUTION: This email originated from an External Sender. Please do not click links or open attachments unless you recognize the source.

ATTENTION : Ce courriel provient d'un expéditeur externe. Ne cliquez sur aucun lien et n'ouvrez pas de pièce jointe, excepté si vous connaissez l'expéditeur.

Hi Brett,

Not sure if you can help me in Amy's absence, but I'm doing a follow up on a comment we received on the 384 Arlington Site Plan Control application. See the attached email.

Please let me know if you can help or if we will need to wait for Amy's return.

Kind Regards,

ERIC POTVIN, P.Eng., ing. (PEO, OIQ, APEY)

Project Manager / Infrastructure

Chargé de projet / Infrastructures

M 613-863-7340 **F** 613-860-1870

600–1400 Blair Towers Place, Ottawa, ON K1J 9B8 CANADA



Engineering
for people



Follow us / Suivez-nous



De : Whelan, Amy <amy.whelan@ottawa.ca>

Envoyé : 8 août 2024 09:25

À : Éric Potvin <Eric.Potvin@cima.ca>

Objet : Automatic reply: 384 Arlington Av. - SPC Phase 3 Civil Comment

EXTERNAL EMAIL

I will be **out** of the **office** Tuesday August 6th, 2024 returning Monday August 19th, 2024. I will respond to your emails upon my return. If you require an immediate response please contact Brett Hughes (brett.hughes@ottawa.ca) .

This e-mail originates from the City of Ottawa e-mail system. Any distribution, use or copying of this e-mail or the information it contains by other than the intended recipient(s) is unauthorized. Thank you.

Le présent courriel a été expédié par le système de courriels de la Ville d'Ottawa. Toute distribution, utilisation ou reproduction du courriel ou des renseignements qui s'y trouvent par une personne autre que son destinataire prévu est interdite. Je vous remercie de votre collaboration.

This e-mail originates from the City of Ottawa e-mail system. Any distribution, use or copying of this e-mail or the information it contains by other than the intended recipient(s) is unauthorized. Thank you.

Le présent courriel a été expédié par le système de courriels de la Ville d'Ottawa. Toute distribution, utilisation ou reproduction du courriel ou des renseignements qui s'y trouvent par une personne autre que son destinataire prévu est interdite. Je vous remercie de votre collaboration.

This e-mail originates from the City of Ottawa e-mail system. Any distribution, use or copying of this e-mail or the information it contains by other than the intended recipient(s) is unauthorized. Thank you.

Le présent courriel a été expédié par le système de courriels de la Ville d'Ottawa. Toute distribution, utilisation ou reproduction du courriel ou des renseignements qui s'y trouvent par une personne autre que son destinataire prévu est interdite. Je vous remercie de votre collaboration.

,

From: Éric Potvin
Sent: August 8, 2024 9:24 AM
To: 'Whelan, Amy'
Cc: Martin Fréchette
Subject: RE: 384 Arlington Av. - SPC Phase 3 Civil Comment
Attachments: [Feedback Form - Phase 3.pdf](#)

Hi Amy,

I'm just doing a follow-up to my email below.

For your reference, it's the comment No. 56 of the attached review feedback letter.

Regards,

ERIC POTVIN, P.Eng., ing. (PEO, OIQ, APEY)
Project Manager / Infrastructure
Chargé de projet / Infrastructures





M 613-863-7340 F 613-860-1870
600–1400 Blair Towers Place, Ottawa, ON K1J 9B8 CANADA



Engineering
for people



KINCEN
Best E
CANADA 20

Follow us / Suivez-nous    

De : Éric Potvin
Envoyé : 2 août 2024 15:50
À : Whelan, Amy <amy.whelan@ottawa.ca>
Cc : Martin Fréchette <Martin.Frechette@cima.ca>
Objet : 384 Arlington Av. - SPC Phase 3 Civil Comment

Hi Amy,

We received the following civil comment as part of our latest SPC submission:

“As per the Phase 1 Pre-consultation notes the entire site is required to be controlled to the pre-development 2-year release rate with a C=0.4 and a minimum Tc of 10min. Discussion with City modeling will be required to determine if it is acceptable to allow area NC1 to release to the right of way uncontrolled.”

Could you assist us in contacting the City modeling group to confirm whether they have any objections to the area at the edge of our site remaining uncontrolled?

Our report, which follows the same approach used in previous projects with the City, shows that the uncontrolled area will feature more pervious landscaping than it currently does. Consequently, it will release less stormwater than it does now in this uncontrolled area. The remainder of the site will be controlled to the 2-year pre-development release rate. Please see the attached pre-development and post-development SWM drawings for reference. We estimate that the post-development runoff for the uncontrolled area (named NC1) will be reduced by approximately 1.9 L/s compared to existing conditions.

Additionally, it's important to note that the site currently does not retain any stormwater – it is all uncontrolled and mostly impervious. Thus, the overall situation of this property will be significantly improved.

Please be aware that the site plan is being modified by the architect, so we will need to adjust our drawings and calculations before resubmitting. However, we plan to maintain the same approach regarding the uncontrolled/unattenuated area.

Thank you for your assistance.

Best regards,

ERIC POTVIN, P.Eng., ing. (PEO, OIQ, APEY)
Project Manager / Infrastructure
Chargé de projet / Infrastructures

M 613-863-7340 F 613-860-1870
600–1400 Blair Towers Place, Ottawa, ON K1J 9B8 CANADA



Engineering
for people



Follow us / Suivez-nous    

De : Pardis Parsa <Pardis.Parsa@cima.ca>

Envoyé : 2 août 2024 11:14

À : Whelan, Amy <amy.whelan@ottawa.ca>

Cc : Éric Potvin <Eric.Potvin@cima.ca>; Anthony Tarabay <Anthony.Tarabay@cima.ca>

Objet : RE: Question About ECA Submission for Property Acquisition

Hi Amy,

Thanks so much for your quick response! I'll reach out to the Ministry for further details. I really appreciate you looking into this and offering to ask around.

Have a great day and enjoy the long weekend ahead!

Best,
Pardis

PARDIS PARSA

Engineering Graduate / Infrastructure



T 613 860-2462 / ✉ pardis.parsa@cima.ca
600-1400 Blair Towers Place, Ottawa, ON K1J 9B8 CANADA



Engineering
for **people**



KINCENTRIC
Best Employer
CANADA 2023

Follow us    

Do you really need to print this email? Let's protect the environment!

CONFIDENTIALITY WARNING This email is confidential. If you are not the intended recipient, please notify the sender immediately and delete it in its entirety.

From: Whelan, Amy <amy.whelan@ottawa.ca>

Sent: Friday, August 2, 2024 10:42 AM

To: Pardis Parsa <Pardis.Parsa@cima.ca>

Cc: Éric Potvin <Eric.Potvin@cima.ca>; Anthony Tarabay <Anthony.Tarabay@cima.ca>

Subject: RE: Question About ECA Submission for Property Acquisition

EXTERNAL EMAIL

Good morning Pardis,

I am not sure what the ministry requirements are so I suggest that you reach out to the ministry to confirm. Apologies that I can not be of more help in this regard. I will also ask around and let you know if anyone in the City may be able to answer.

Best,

Amy

From: Pardis Parsa <Pardis.Parsa@cima.ca>

Sent: August 02, 2024 9:56 AM

To: Whelan, Amy <amy.whelan@ottawa.ca>

Cc: Éric Potvin <Eric.Potvin@cima.ca>; Anthony Tarabay <Anthony.Tarabay@cima.ca>

Subject: Question About ECA Submission for Property Acquisition

CAUTION: This email originated from an External Sender. Please do not click links or open attachments unless you recognize the source.

ATTENTION : Ce courriel provient d'un expéditeur externe. Ne cliquez sur aucun lien et n'ouvrez pas de pièce jointe, excepté si vous connaissez l'expéditeur.

Hi Amy,

I hope you're having a great day!

I have a quick question about the ECA application process. Our client is in the process of acquiring a property, but they don't own it yet. Would it be sufficient to include a signed letter from the current owner (a Church) authorizing our client to submit the ECA? If there's a better approach or any additional steps we should consider, I'd appreciate your advice.

I appreciate your help and have a great weekend!

PARDIS PARSA

Engineering Graduate / Infrastructure



T 613 860-2462 / ✉ pardis.parsa@cima.ca

600-1400 Blair Towers Place, Ottawa, ON K1J 9B8 CANADA



Engineering
for people



KINCENTRIC
Best Employer

CANADA 2023

Follow us    

Do you really need to print this email? Let's protect the environment!

CONFIDENTIALITY WARNING This email is confidential. If you are not the intended recipient, please notify the sender immediately and delete it in its entirety.

,

This e-mail originates from the City of Ottawa e-mail system. Any distribution, use or copying of this e-mail or the information it contains by other than the intended recipient(s) is unauthorized. Thank you.

Le présent courriel a été expédié par le système de courriels de la Ville d'Ottawa. Toute distribution, utilisation ou reproduction du courriel ou des renseignements qui s'y trouvent par une personne autre que son destinataire prévu est interdite. Je vous remercie de votre collaboration.

,

Appendix A

4 - PRE-CONSULTATION WITH MECP FOR ECA APPLICATION

From: Pardis Parsa
Sent: August 21, 2024 4:10 PM
To: Whelan, Amy
Cc: Éric Potvin; Anthony Tarabay
Subject: RE: Question About ECA Submission for Property Acquisition

Hi Amy,

Thank you for the information and for getting back to me. I'll get the confirmation letter from the landowner.

Kind regards,

PARDIS PARSA
Engineering Graduate / Infrastructure



T 613 860-2462 / ✉ pardis.parsa@cima.ca
600-1400 Blair Towers Place, Ottawa, ON K1J 9B8 CANADA



Engineering
for **people**



KINCENTRIC
Best Employer
CANADA 2023

Follow us    

Do you really need to print this email? Let's protect the environment!

CONFIDENTIALITY WARNING This email is confidential. If you are not the intended recipient, please notify the sender immediately and delete it in its entirety.

From: Whelan, Amy <amy.whelan@ottawa.ca>
Sent: Wednesday, August 21, 2024 11:18 AM
To: Pardis Parsa <Pardis.Parsa@cima.ca>

Cc: Éric Potvin <Eric.Potvin@cima.ca>; Anthony Tarabay <Anthony.Tarabay@cima.ca>
Subject: RE: Question About ECA Submission for Property Acquisition

EXTERNAL EMAIL

Good morning Pardis,

Apologies for the late reply I was away on vacation. An application for an ECA can be made by a person that does not own the land. It simply requires confirmation from the landowner. Usually in a letter.

Kind regards,

Amy Whelan, E.I.T

Project Manager, Infrastructure Approvals
Development Review, Central | Examen des projets d'aménagement, Central
Planning, Development and Building Services Department (PDBS) | Direction générale des services de la planification, de l'aménagement et du bâtiment (DGSPAB)
City of Ottawa | Ville d'Ottawa
110 Laurier Avenue West Ottawa, ON | 110, avenue. Laurier Ouest. Ottawa (Ontario) K1P 1J1
613.580.2424 ext./poste 26642, amy.whelan@ottawa.ca

From: Pardis Parsa <Pardis.Parsa@cima.ca>
Sent: August 02, 2024 11:14 AM
To: Whelan, Amy <amy.whelan@ottawa.ca>
Cc: Éric Potvin <Eric.Potvin@cima.ca>; Anthony Tarabay <Anthony.Tarabay@cima.ca>
Subject: RE: Question About ECA Submission for Property Acquisition

CAUTION: This email originated from an External Sender. Please do not click links or open attachments unless you recognize the source.

ATTENTION : Ce courriel provient d'un expéditeur externe. Ne cliquez sur aucun lien et n'ouvrez pas de pièce jointe, excepté si vous connaissez l'expéditeur.

Hi Amy,

Thanks so much for your quick response! I'll reach out to the Ministry for further details. I really appreciate you looking into this and offering to ask around.

Have a great day and enjoy the long weekend ahead!

Best,
Pardis

PARDIS PARSA

Engineering Graduate / Infrastructure



T 613 860-2462 / ✉ pardis.parsa@cima.ca
600-1400 Blair Towers Place, Ottawa, ON K1J 9B8 CANADA



Engineering
for people



KINCENTRIC
Best Employer
CANADA 2023

Follow us    

Do you really need to print this email? Let's protect the environment!

CONFIDENTIALITY WARNING This email is confidential. If you are not the intended recipient, please notify the sender immediately and delete it in its entirety.

From: Whelan, Amy <amy.whelan@ottawa.ca>

Sent: Friday, August 2, 2024 10:42 AM

To: Pardis Parsa <Pardis.Parsa@cima.ca>

Cc: Éric Potvin <Eric.Potvin@cima.ca>; Anthony Tarabay <Anthony.Tarabay@cima.ca>

Subject: RE: Question About ECA Submission for Property Acquisition

EXTERNAL EMAIL

Good morning Pardis,

I am not sure what the ministry requirements are so I suggest that you reach out to the ministry to confirm. Apologies that I can not be of more help in this regard. I will also ask around and let you know if anyone in the City may be able to answer.

Best,

Amy

From: Pardis Parsa <Pardis.Parsa@cima.ca>
Sent: August 02, 2024 9:56 AM
To: Whelan, Amy <amy.whelan@ottawa.ca>
Cc: Éric Potvin <Eric.Potvin@cima.ca>; Anthony Tarabay <Anthony.Tarabay@cima.ca>
Subject: Question About ECA Submission for Property Acquisition

CAUTION: This email originated from an External Sender. Please do not click links or open attachments unless you recognize the source.

ATTENTION : Ce courriel provient d'un expéditeur externe. Ne cliquez sur aucun lien et n'ouvrez pas de pièce jointe, excepté si vous connaissez l'expéditeur.

Hi Amy,

I hope you're having a great day!

I have a quick question about the ECA application process. Our client is in the process of acquiring a property, but they don't own it yet. Would it be sufficient to include a signed letter from the current owner (a Church) authorizing our client to submit the ECA? If there's a better approach or any additional steps we should consider, I'd appreciate your advice.

I appreciate your help and have a great weekend!

PARDIS PARSA

Engineering Graduate / Infrastructure



T 613 860-2462 / ✉ pardis.parsa@cima.ca
600-1400 Blair Towers Place, Ottawa, ON K1J 9B8 CANADA



Engineering
for people



KINCENTRIC
Best Employer
CANADA 2023

Follow us    

Do you really need to print this email? Let's protect the environment!

CONFIDENTIALITY WARNING This email is confidential. If you are not the intended recipient, please notify the sender immediately and delete it in its entirety.

,

This e-mail originates from the City of Ottawa e-mail system. Any distribution, use or copying of this e-mail or the information it contains by other than the intended recipient(s) is unauthorized. Thank you.

Le présent courriel a été expédié par le système de courriels de la Ville d'Ottawa. Toute distribution, utilisation ou reproduction du courriel ou des renseignements qui s'y trouvent par une personne autre que son destinataire prévu est interdite. Je vous remercie de votre collaboration.

,

,

This e-mail originates from the City of Ottawa e-mail system. Any distribution, use or copying of this e-mail or the information it contains by other than the intended recipient(s) is unauthorized. Thank you.

Le présent courriel a été expédié par le système de courriels de la Ville d'Ottawa. Toute distribution, utilisation ou reproduction du courriel ou des renseignements qui s'y trouvent par une personne autre que son destinataire prévu est interdite. Je vous remercie de votre collaboration.

,

Pardis Parsa

From: Funakoshi, Didier (MECP) <Didier.Funakoshi@ontario.ca>
Sent: May 29, 2024 10:00 AM
To: Pardis Parsa
Cc: Environmental Permissions (MECP); Diamond, Emily (MECP)
Subject: RE: Request for ECA and MECP Approval Forms for Development Project at 384 Arlington Avenue (A001272)

EXTERNAL EMAIL

Hi Paradis,

Thank you for reaching out.

In addition to the sections you have highlighted, please include also the following:

- 1) Section 3: EBR, EAA and indigenous consultation
- 2) Section 6.1 (yes or no)
- 3) Authorization page: sections 7.1, 7.2 and 7.3. If the ECA Applicant is the City of Ottawa (Municipality), only section 7.1 is required (no need to complete section 7.2). CIMA will have to complete, sign and date 7.3

If there are any other inquiries, please let me know.

Regards,

Didier Funakoshi | Environmental Assessment and Permissions Division

|Ministry of the Environment, Conservation and Parks: 135 St. Clair Ave W. 1st Floor Toronto, Ontario, M4V 1P5 | 📞 (437) 237-7618 | 📠 (416) 314-8452 | ✉️ didier.funakoshi@ontario.ca

From: Environmental Permissions (MECP) <enviropermissions@ontario.ca>

Sent: Wednesday, May 29, 2024 9:12 AM

To: Funakoshi, Didier (MECP) <Didier.Funakoshi@ontario.ca>

Cc: Environmental Permissions (MECP) <enviropermissions@ontario.ca>

Subject: FW: Request for ECA and MECP Approval Forms for Development Project at 384 Arlington Avenue (A001272)

Hello Didier,

Could you please assist with the inquiry below? To meet our Service Standards, please CC enviropermissions@ontario.ca on your response to the client. If a final response cannot be provided immediately, provide an interim response to the client within 2 business days and a complete answer within 15 business days.

Thank you,

Isaac Foley (on behalf of Environmental Permissions)

Client Service Representative

Client Services & Permissions Branch (CSPB)

Ministry of the Environment, Conservation and Parks

135 St. Clair Avenue West, 1st Floor

Toronto, ON M4V 1P5

General Inquiries: E: enviropemissions@ontario.ca | P: 416-314-8001 | F: 416-314-8452

***New* Environmental Permissions Online Services – Videos**

If you have any accommodation needs or require communication supports or alternate formats, please let me know.

Si vous avez des besoins en matière d'adaptation, ou si vous nécessitez des aides à la communication ou des médias substitués, veuillez me le faire savoir.

Did you know? At this time, the ministry strongly encourages online submissions for some environmental permissions. You can submit your application and supporting documents, make payments, and track application progress online. For more information, please visit the [ministry website](#) or you may contact the Client Services and Permissions Branch by phone at 416-314-8001 or 1-800-461-6290, or by email at enviropemissions@ontario.ca.

From: Pardis Parsa <Pardis.Parsa@cima.ca>

Sent: Monday, May 27, 2024 4:41 PM

To: Environmental Permissions (MECP) <enviropemissions@ontario.ca>

Cc: Éric Potvin <Eric.Potvin@cima.ca>; Martin Fréchette <Martin.Frechette@cima.ca>

Subject: FW: Request for ECA and MECP Approval Forms for Development Project at 384 Arlington Avenue (A001272)

CAUTION -- EXTERNAL E-MAIL - Do not click links or open attachments unless you recognize the sender.

Hello,

I'm contacting you on behalf of CIMA+ and the City of Ottawa regarding the proposed development at 384 Arlington Ave. As per Emily Diamond's email below, we need to complete an ECA application due to our proposed Combined Sewer Connection. We want to ensure we're filling out all required sections for this type of application.

Could you please confirm the highlighted sections are correct or if additional sections need to be completed?

For your reference, please find the proposed development information below.

1. Type of Development and Units: *The proposed development involves the construction of a 24-storey mixed-use building (residential and commercial space) with an underground 2-level parking garage.*

2. Site Address: *384 Arlington Avenue*

3. location of services: The development will connect sanitary and storm sewers separately to the existing 300 mm diameter PVC combined sewer in Bell Street North.

4. Stormwater Management: Stormwater will be stored in an underground tank, with release rates controlled to the 2-year pre-development condition and storage provided up to the 100-year post-development condition.

Thank you for your assistance.

Best regards,

PARDIS PARSA

Engineering Graduate / Infrastructure



T 613 860-2462 / ✉ pardis.parsa@cima.ca

600-1400 Blair Towers Place, Ottawa, ON K1J 9B8 CANADA



Engineering
for people



KINCENTRIC
Best Employer
CANADA 2023

Follow us    

Do you really need to print this email? Let's protect the environment!

CONFIDENTIALITY WARNING This email is confidential. If you are not the intended recipient, please notify the sender immediately and delete it in its entirety.

From: Diamond, Emily (MECP) <Emily.Diamond@ontario.ca>

Sent: Wednesday, May 15, 2024 3:35 PM

To: Pardis Parsa <pardis.parsa@cima.ca>; Éric Potvin <Eric.Potvin@cima.ca>

Subject: RE: Request for ECA and MECP Approval Forms for Development Project at 384 Arlington Avenue (A001272)

EXTERNAL EMAIL

Good Afternoon Pardis and Eric,

This email is in regards to the pre-consultation meeting that was held today. I have no concerns about the proposed project going forward and agree that an Environmental Compliance Approval for

the stormwater management is required due to the discharge to the combined sewers. You may use this email as a record of pre-consultation.

You have likely come across this page already, but the information on this page may be useful as you are going through the application process:

[Environmental Compliance Approval | ontario.ca](#)

The completed application should be sent to the following email, ECA.submission@ontario.ca. Feel free to copy me on it as well.

If you have any further questions for me, please let me know. If you have any questions regarding the application form, please reach out to the Client Services and Permissions Branch at 416-314-8001 or by email at enviropemissions@ontario.ca

Thank you and have a great rest of the day.

Emily Diamond

Environmental Compliance Officer | Ottawa District Office | Eastern Region
Ministry of the Environment, Conservation and Parks | Government of Ontario
(613)-866-0938 | firstname.lastname@ontario.ca

2430 Don Reid Drive
Ottawa ON K1H 1E1



We want to hear from you. How was my service? You can provide feedback at 1-888-745-8888 or www.ontario.ca/inspectionfeedback. Nous attendons vos commentaires. Qu'avez-vous pensé de mon service? Vous pouvez nous faire part de vos commentaires au 1-888-745-8888 ou à www.ontario.ca/retroactioninspection.

Are reporting a spill? Please contact the Ministry of the Environment, Conservation and Parks, Spills Action Centre at (416)325-3000 or 1(800) 268-6060.

Are you reporting a pollution incident or environmental concern? Please use the ministry's [online pollution reporting tool](#) or for more urgent matters contact the Pollution Hotline at 1(866) 663-8477.

From: Pardis Parsa <Pardis.Parsa@cima.ca>

Sent: April 23, 2024 3:38 PM

To: Primeau, Charlie (MECP) <Charlie.Primeau@ontario.ca>; Diamond, Emily (MECP) <Emily.Diamond@ontario.ca>

Subject: Request for ECA and MECP Approval Forms for Development Project at 384 Arlington Avenue (A001272)

CAUTION -- EXTERNAL E-MAIL - Do not click links or open attachments unless you recognize the sender.

Hello,

I hope this email finds you well. I am reaching out on behalf of CIMA+ and the City of Ottawa regarding a project in Ottawa, Ontario.

We've recently wrapped up an assessment confirming that the proposed 24-storey residential tower with 274 units at 384 Arlington Avenue can be well serviced by existing municipal infrastructure in terms of water and combined sewer systems. We are aiming to get Environmental Compliance Approval (ECA) for the project.

Could you please help us out by providing the necessary forms and documentation for the approval process?

Your assistance would be greatly appreciated. If there's anything more you need from our end, please let me know.

Best regards,
Pardis Parsa

PARDIS PARSA

Engineering Graduate / Infrastructure



T 613 860-2462 / ✉ pardis.parsa@cima.ca

600–1400 Blair Towers Place, Ottawa, ON K1J 9B8 CANADA



Engineering
for people



KINCENTRIC
Best Employer
CANADA 2023

Follow us    

Do you really need to print this email? Let's protect the environment!

CONFIDENTIALITY WARNING This email is confidential. If you are not the intended recipient, please notify the sender immediately and delete it in its entirety.

Appendix A

5 - PRE-CONSULTATION WITH RVCA

From: [Eric Lalande](#)
To: [Tim Kennedy](#)
Cc: [Jamie Batchelor](#)
Subject: RE: 384 Arlington Av. - Servicing Capacity Assessment - RVCA Pre-consult
Date: Monday, July 18, 2022 3:35:27 PM

EXTERNAL EMAIL

Hi Tim,

Based on the proposed site plan details, and combined sewer outlet, the RVCA has no water quality control requirements, as it will rely on municipal infrastructure. Further, there are no natural features identified on the subject site.

Thanks,

Eric Lalande, MCIP, RPP
Planner, RVCA
613-692-3571 x1137

From: Tim Kennedy <Tim.Kennedy@cima.ca>
Sent: Monday, July 18, 2022 3:24 PM
To: Eric Lalande <eric.lalande@rvca.ca>
Cc: Jamie Batchelor <jamie.batchelor@rvca.ca>
Subject: FW: 384 Arlington Av. - Servicing Capacity Assessment - RVCA Pre-consult
Importance: High

Hi Eric,

Please see below and attached.

Are you able to provide a response in Jamie's absence?

Thanks,
Tim

TIM KENNEDY, P.Eng.
Senior Project Manager / Infrastructure

T 613-860-2462 ext. 6620 M 613-462-3627 F 613-860-1870
110-240 Catherine Street, Ottawa, ON K2P 2G8 CANADA



Engineering
for people



KINCENTRIC
Best Employer
CANADA 2021

Do you really need to print this email? Let's protect the environment!

CONFIDENTIALITY WARNING This email is confidential. If you are not the intended recipient, please notify the sender immediately and delete it in its entirety.

From: Tim Kennedy
Sent: Monday, July 18, 2022 3:19 PM
To: Jamie Batchelor <jamie.batchelor@rvca.ca>
Cc: Jaymeson Adams <Jaymeson.Adams@cima.ca>; Gavin Joseph <Gavin.Joseph@cima.ca>
Subject: 384 Arlington Av. - Servicing Capacity Assessment - RVCA Pre-consult
Importance: High

Hi Jamie,

We are working on another development project in the City of Ottawa, and I wanted to get your input on Natural Heritage/Hazards features that may impact the development as well as any Stormwater Management Criteria for the site and required approvals/permits.

The proposed development involves the construction of a twenty-four (24) storey mixed use commercial and residential development at 384 Arlington Avenue in Ottawa, Ontario, with underground parking (no proposed surface parking spots).

A few specific items for your consideration as follow:

1. The development will connect to the existing 300 mm \varnothing combined sewer within Bell Street North.
2. Stormwater will be stored in an underground tank/cistern. Allowable release rate will be controlled to the 2-year pre-development condition and storage provide up to the 100-year post development condition.
3. The proposed underground parking will encompass the entire site.
4. Considering the above we do not expect that on-site water quality control would be required.

I have attached a key plan with the site location (PDF document) for your reference.

Please do not hesitate to contact me if you have any questions, want to discuss or need clarification. Hoping to have a quick response on this one as I would like to submit the Servicing Report to our client for review by end of this week.

Thanks,
Tim

TIM KENNEDY, P.Eng.
Senior Project Manager / Infrastructure

T 613-860-2462 ext. 6620 M 613-462-3627 F 613-860-1870
110-240 Catherine Street, Ottawa, ON K2P 2G8 CANADA



Engineering
for people



KINCENTRIC
Best Employer
CANADA 2021

Do you really need to print this email? Let's protect the environment!

CONFIDENTIALITY WARNING This email is confidential. If you are not the intended recipient, please notify the sender immediately and delete it in its entirety.

Appendix A

6 - PRE-CONSULTATION WITH CITY

Subject: FW: Pre-con Follow-up - 384 Arlington
Date: Monday, February 7, 2022 at 2:46:31 PM Eastern Standard Time
From: Ghada Zaki
To: Miguel Tremblay, Justin George, Stephen Savell, Kristen Jorgensen
CC: Tamara Nahal
Attachments: 384 Arlington - Study and Plan Identification List.pdf, design_brief_submission requirements_384 Arlington.pdf, torwindanalysis_en.pdf, image001.gif, image003.jpg

Good afternoon,

Please note that we have just received the Pre-con follow-up and minutes. Please see below and attached
Thanks and looking forward to our discussion tomorrow,

Ghada Zaki, RPP, MCIP

Senior Planner

T 613.730.5709 ext. 226 **As I am working remotely, please email me to set up a phone call**

From: Nadeau, Jeff <jeff.nadeau@ottawa.ca>
Sent: February 7, 2022 2:39 PM
To: Ghada Zaki <zaki@fotenn.com>; Tamara Nahal <nahal@fotenn.com>
Cc: Kotarba, Ashley <Ashley.Kotarba@ottawa.ca>; Wang, Randolph <Randolph.Wang@ottawa.ca>; Gervais, Josiane <josiane.gervais@ottawa.ca>; Fawzi, Mohammed <mohammed.fawzi@ottawa.ca>; thesycamore <thesycamore@sympatico.ca>
Subject: Pre-con Follow-up - 384 Arlington

CAUTION: This email is from an external sender. Do not click links or open attachments unless you recognize the sender and know the content is safe.

CC: Ashley Kotarba, Randolph Wang, Mohammed Fawzi, Josiane Gervais, David Seaborn

Hello Ghada & Tamara,

Please refer to the below [and/or attached notes] regarding the Pre-Application Consultation (“pre-con”) Meeting held on January 14 for the property at 384 Arlington Avenue for Site Plan Control and Zoning By-law Amendment in order to allow the development of a 12-storey residential building by Windmill. I have also attached the required Plans & Study List for application submission.

Below are staff’s preliminary comments based on the information available at the time of pre-con meeting:

PLANNING

- Under the current Official Plan, the lands are designated General Urban. Under the new Official Plan, the site is Downtown Core (Section 5.1) / Neighbourhood (Section 6.3). Applications submitted before Ministry approval of the new Official Plan will be evaluated on the basis of the existing Official Plan with regard for the new Official Plan; the more restrictive policies will apply.
 - Policies 2 and 3 of Section 6.3.1 in the new Official Plan stipulate that building heights in Neighbourhood may exceed the generally low-rise format (a) where existing zoning or secondary plans allow for greater heights, or (b) in areas already

characterized by taller buildings. It is thus the view of the Department, based on Policy 2(b), that no OPA is required for this proposal given the proximity of a 12-storey building on Bell Street and that the additional height may be sought through ZBLA.

- The site is zoned I1A. The intent to rezone it as R5 is understood, and staff concur that it is appropriate.
- The massing of the proposed building will need to be resolved.
 - Heritage and Urban Design have raised concerns about the relationship of the proposed building to the existing church, which will be reviewed for potential *Heritage Act* designation during the 60-day notice period described in the Heritage notes below. Pending any designation arising from that process, Planning is neutral with regard to the church. In the absence of a designation, the Department's priority must be a building form and program that contributes to a high-quality urban place and complies with Official Plan direction relating to design and compatibility.
 - Retention of the existing building in a way that adds value to the project would nonetheless be viewed as a positive – Section 6.3.2 of the new Official Plan includes adaptive reuse as an example of innovative building forms to be supported.
 - The relationship to the east lot line, and to neighbouring buildings sharing Arthur Lane should be reconsidered. It appears that this concept treats its parcel as a standalone city block, with Arthur Lane functioning as a street, whereas given that this is a narrow laneway a rear-yard condition would be expected. Consider, for example, the setbacks of the large buildings to the north from Arthur Lane. Another analogous condition, as mentioned in our meeting, would be the lanes between Breezehill, Bayswater and Spadina Avenues in Hintonburg. Lot lines abutting these lands are treated as rear lot lines with the attendant setbacks and landscaping. It is understood that the context for this site is a more urban condition, however some sort of built-form transition would be advisable.
 - As such, staff recommend exploring different expressions of the volume of this building.
 - This application is not subject to the UDRP by default, but we have the option of recommending it. In the event that a follow-up preconsult meeting proves inconclusive, review and comment from the UDRP may illuminate a path forward.
- It seems likely that community benefits (“Section 37”) will be triggered by the density increase being proposed.
- For a Zoning By-law Amendment, the Applicant must now provide a proposed strategy for public consultation as directed by Bill 73.

URBAN DESIGN

- A Design Brief is required for the submission. The Terms of Reference of Design Brief is attached for convenience.
 - Please study massing options.
 - Please note wind and shadow studies are required.
- With respect to the preliminary concept presented at the meeting, the incorporation of some aspects of the heritage attributes into the design and the provision of a public accessible space are appreciated. However, the overall site plan and massing appears to be overwhelming for the heritage assets, the site and the surroundings.

- The 12-storey “slab” does not foster a good relationship with the narrow lane of Author and the adjacent low-rise neighbourhood.
 - The small 20m × 20m “public space” is a little bit squashed comparing with the 9 storey and 12 storey buildings surrounding it.
 - The addition above the proposed reconstructed heritage building is unconvincing.
- In the new Official Plan, the site is within the Neighbourhood designation of the Downtown Transect. The new OP supports low-rise development in this designation but also allows for opportunities to explore taller building options in an area that is characterized by taller buildings. When exploring options on this site, please consider the following in addition to many policies and practical considerations:
 - Locate taller building away from low-rise residential areas and the narrow lane;
 - Respect the low-rise scale and character of Arlington and Bell, where the heritage building is situated.
 - Provide effective transition from any tall buildings to the low-rise areas, in this case, transition to areas east of Author and west of Bell should both be considered. Please refer to the relevant OP policies for guidance.
 - If a high-rise building is considered, please refer to the Urban Design Guidelines for High-Rise Buildings for guidance, and use angular plane as a tool to guide the design for built form transition.
 - Include a 2 or 3-storey podium to reflect on the scale of the adjacent low-rise residential areas.
 - Incorporate grade-related units to reflect the architectural rhythm of the adjacent low-rise residential areas.
 - Include a publicly accessible space at grade, and make sure optimal microclimate conditions.
 - Allow for landscaping opportunities on all public streets and lane, particularly Raymond Street.
- The site is not within a designated Design Priority Area and generally it is not subject to the review by the City’s Urban Design Review Panel. However, due to the complexity of the proposed development and the inclusion of heritage resources on site, the applicant can benefit from the review(s) of the UDRP.
- As indicated above, the currently proposed site plan and massing option is unconvincing and problematic in a number of ways. It is recommended that the applicants explore additional site plan and massing options and return for a second staff preconsultation. The merits and process of UDRP review(s) can be determined at the second staff preconsultation where such alternative site plan and massing options are presented and discussed.

HERITAGE

- The property at 384 Arlington Street is listed on the City's Heritage Register as a non-designated listing. This includes both the church and the manse. The property was added for having potential cultural heritage value or interest. Being listed on the Heritage Register means that the owner needs to provide the City with 60 day's notice of their intention to demolish either building. The owner will need to complete the Form for Buildings Listed on the Heritage Register (link below), and provide supporting documentation (rationale for demolition, any supporting historical documents, photos to document the building). A Heritage Impact Assessment and Conservation Plan may be useful to support the demolition and development applications. These documents should look at the historical and architectural interest of the church and manse, and evaluate how the proposal will impact any each resource. Also, a conservation plan should look at the structural integrity of the church, and recommend an approach that salvages as much original material as possible, while rebuilding areas that are severely compromised.
- [Form for Buildings Listed on the Heritage Register \(ottawa.ca\)](#)
- During the 60 days, staff will determine if the building(s) warrants designation under Part IV of the *Ontario Heritage Act*. If it does not, the 60 days will be allowed to expire. Please note that building/demolition permits cannot be issued until the 60 days have lapsed. For these reasons, it is recommended that the applicant submit the form at the time of the site plan application.
- Heritage staff are pleased to see development on this site, however there is strong concern over the limited conservation of the church building and the massing proposed on top. This is not in alignment with *Parks Canada's Standards and Guidelines for the Conservation of Historic Places*, nor the City's Official Plan.
- Heritage staff encourage the applicant to consider shifting the massing from on top of the church and redistributing it elsewhere on the site. See comments from Urban Design for direction.
- Further, more of the original brick church building should be conserved and integrated into the development. Any parts that are structurally unsound can be rebuilt. See example below of St. Charles Church in Vanier. The new mass is located next to the church, and the entire church building is kept, and integrated into the development.



ENGINEERING

Available Infrastructure:

Arlington Avenue:

Combined: 300mm PVC (Install 2003)

Water: 200mm PVC (Install 2003)

Bell Street North

Combined: 300mm PVC (Install 2002)

Water: 150mm PVC (Install 2002)

Water Boundary Conditions:

Will be provided at request of consultant. Requests must include the location of the service and the expected loads required by the proposed development. Please provide the following and submit Fire Flow Calculation Sheet per FUS method with the request:

- Location of service
- Type of development and amount of required fire flow (per FUS method – include FUS calculation sheet with request)
- Average Daily Demand (l/s)
- Maximum Hourly Demand (l/s)
- Maximum Daily Demand (l/s)
- Water Supply Redundancy – Fire Flow:
 - Applicant to ensure that a second service with an inline valve chamber be provided where the average daily demand exceeds 50 m³ / day (0.5787 l/s per day)

Water services larger than 19 mm require a Water Data Card. Please complete card and submit.

Stormwater Management:

- Coefficient (C) of runoff determined **as per existing conditions** but in no case more than 0.4.
- TC = To be calculated, minimum 10 minutes
- Any storm events greater than 2 year, up to 100 year, and including 100-year storm event must be detained on site.
- Foundation drains are to be independently connected to sewer main unless being pumped with appropriate back up power, sufficient sized pump and back flow prevention.
- Roof drains are to be connected downstream of any incorporated ICD within the SWM system.

Stormwater Management Criteria (Quality Control)

Include a section in the SWM report concerning quality control requirements. It is the consultant's responsibility to check with the relevant Conservation Authority for quality control issues and include this information in the SWM report.

Noise and Vibration Study:

Noise Study required due to proximity of 417 Highway.

Phase I and Phase II ESA:

- Phase I ESA is required; Phase II ESA may be required depending on the results of the Phase I ESA. Phase I ESA must include an EcoLog ERIS Report.
- Phase I ESA and Phase II ESAs must conform to clause 4.8.4 of the Official Plan that requires

that development applications conform to Ontario Regulation 153/04.

Required Studies

- Stormwater Management Report
- Site Servicing Study
- Geotechnical Study
- Phase I ESA
- Phase II ESA (depends on outcome of Phase I)
- Noise Study

-

Required Plans

- Site Servicing Plan
- Grade Control and Drainage Plan
- Erosion and Sediment Control Plan (Can be combined with grading plan)

-

ECA Application will be required

Please provide one copy the following (following approval):

- MECP ECA Application Form - TOR or Direct Submission tied to SPC Fees - Certified Cheque made out to "City of Ottawa"
- Proof of Applicant's Identification
- Certificate of Incorporation (if Applicable)
- NAICS Code (If Applicable)
- Plan & Profile
- Grading and Servicing Plans
- Survey Plan
- Pipe Data Form
- Relevant information

General

1. The Servicing Study Guidelines for Development Applications are available at the following address: <https://ottawa.ca/en/city-hall/planning-and-development/information-developers/development-application-review-process/development-application-submission/guide-preparing-studies-and-plans#servicing-study-guidelines-development-applications>
2. Servicing and site works shall be in accordance with the following documents:
 - Ottawa Sewer Design Guidelines (October 2012)
 - Ottawa Design Guidelines – Water Distribution (2010)
 - Geotechnical Investigation and Reporting Guidelines for Development Applications in the City of Ottawa (2007)
 - City of Ottawa Slope Stability Guidelines for Development Applications (revised 2012)
 - City of Ottawa Environmental Noise Control Guidelines (January, 2016)
 - City of Ottawa Park and Pathway Development Manual (2012)
 - City of Ottawa Accessibility Design Standards (2012)
 - Ottawa Standard Tender Documents (latest version)
 - Ontario Provincial Standards for Roads & Public Works (2013)
3. Record drawings and utility plans are also available for purchase from the City (Contact the City's Information Centre by email at InformationCentre@ottawa.ca or by phone at (613) 580-

2424 x.44455).

4. Any proposed work in utility easements requires written consent of easement owner.

Feel free to contact the Infrastructure Project Manager, Mohammed Fawzi, at mohammed.fawzi@ottawa.ca, for follow-up questions.

TRANSPORTATION

- Follow Transportation Impact Assessment Guidelines
 - A TIA is required. The scoping report can be submitted together to Josiane.Gervais@ottawa.ca at your earliest convenience.
 - The site is located within the “Urban” area designation, as referenced on the Transportation Master Plan ‘Inner Urban’ area (i.e. 400m Radius for study area).
 - Start this process asap. The application will not be deemed complete until the submission of the draft step 1-4, including the functional draft RMA package (if applicable) and/or monitoring report (if applicable).
 - Request base mapping asap if RMA is required. Contact Engineering Services (<https://ottawa.ca/en/city-hall/planning-and-development/engineering-services>)
 - An update to the *TRANS Trip Generation Manual* has been completed (October 2020). This manual is to be utilized for this TIA. A copy of this document can be provided upon request.
- Corner triangles as per OP Annex 1 - Road Classification and Rights-of-Way at the following locations on the final plan will be required (measure on the property line/ROW protected line; no structure above or below this triangle): Local Road to Local Road: 3 m x 3 m
- Sight triangle as per Zoning by-law Section 57 is to be measured on the curb line.
- Corner clearances should follow minimum distances set out within TAC Figure 8.8.2.
- TMP includes:
 - Future LRT Station at Corso Italia (2031 Affordable Network), this station is located within an 800m radius of the site.
 - Transit Priority Corridor (Isolated Measures) (2031 Affordable Network) along Bronson Ave
 - Transit Priority Corridor (Isolated Measures) (Ultimate Network) along Bronson Ave
- On site plan:
 - Ensure site access meets the City’s Private Approach Bylaw.
 - Show all details of the roads abutting the site up to and including the opposite curb; include such items as pavement markings, accesses and/or sidewalks.
 - Turning movement diagrams required for all accesses showing the largest vehicle to access/egress the site.
 - Turning movement diagrams required for internal movements (loading areas, garbage) where applicable.
 - Show all curb radii measurements; ensure that all curb radii are reduced as much as possible and fall within TAC guidelines (Figure 8.5.1).
 - Show dimensions for site elements (i.e. lane/aisle widths, access width, parking stalls, sidewalks, pedestrian pathways, etc.)
 - Sidewalk is to be continuous across access as per City Specification 7.1.
 - Show slope of garage ramp on site plan. Note that underground ramps should be limited to a 12% grade and must contain a subsurface melting device when exceeding 6%. Ramp grades greater than 15% can be psychological barriers to some drivers.
 - Parking stalls at the end of dead-end parking aisles require adequate turning around space
 - Grey out any area that will not be impacted by this application.

- As the site proposed is residential, AODA legislation applies for all areas accessible to the public (i.e. outdoor pathways, parking, etc.). Consider using the City's Accessibility Design Standards.

Feel free to contact the Transportation Project Manager, Josiane Gervais, at josiane.gervais@ottawa.ca, for follow-up questions.

CITY SURVEYOR

- The determination of property boundaries, minimum setbacks and other regulatory constraints are a critical component of development. An Ontario Land Surveyor (O.L.S.) needs to be consulted at the outset of a project to ensure properties are properly defined and can be used as the geospatial framework for the development.
- Topographic details may also be required for a project and should be either carried out by the O.L.S. that has provided the Legal Survey or done in consultation with the O.L.S. to ensure that the project is integrated to the appropriate control network.

Questions regarding the above requirements can be directed to the City's Surveyor, Bill Harper, at bill.harper@ottawa.ca.

OTHER

- Plans are to be standard A1 size (594 mm x 841 mm) sheets, utilizing an appropriate Metric scale (1:200, 1:250, 1:300, 1:400 or 1:500).
- All PDF submitted documents are to be unlocked and flattened.
- For sites containing one or more buildings with a total GFA greater than 2000 square metres: a Waste Reduction Workplan Summary is required for the construction project as required by O.Reg. 102/94, being "Waste Audits and Waste Reduction Work Plans" made under the Environmental Protection Act, RSO 1990, c E.19, as amended.
- You are encouraged to contact the Ward Councillor, Councillor McKenney, at catherine.mckenney@ottawa.ca about the proposal. You may also consider contacting the Dalhousie Community Association.

Please refer to the links to [Guide to preparing studies and plans](#) and [fees](#) for further information. Additional information is available related to [building permits](#), [development charges](#), and the [Accessibility Design Standards](#). Be aware that other fees and permits may be required, outside of the development review process. You may obtain background drawings by contacting informationcentre@ottawa.ca.

These pre-con comments are valid for one year. If you submit a development application(s) after this time, you may be required to meet for another pre-consultation meeting and/or the submission requirements may change. You are as well encouraged to contact us for a follow-up meeting if the plan/concept will be further refined.

Please do not hesitate to contact me if you have any questions.

Regards,

Jeff Nadeau

Planner II | Urbaniste II

Development Review, Central | *Examen des projets d'aménagement, Central*

Planning, Real Estate and Economic Development Department | *Services de la planification, des biens immobiliers et du développement économique*

City of Ottawa | *Ville d'Ottawa*

110 Laurier Avenue West. Ottawa, ON | *110, avenue. Laurier Ouest. Ottawa (Ontario) K1P 1J1*

☎ 613.580.2424 ext./poste 16802

ottawa.ca/planning/ / ottawa.ca/urbanisme

*****Please note that, while my work hours may be affected by the current situation, I have regular access to email and check telephone messages periodically. Email is currently the best way to contact me*****

This e-mail originates from the City of Ottawa e-mail system. Any distribution, use or copying of this e-mail or the information it contains by other than the intended recipient(s) is unauthorized. Thank you.

Le présent courriel a été expédié par le système de courriels de la Ville d'Ottawa. Toute distribution, utilisation ou reproduction du courriel ou des renseignements qui s'y trouvent par une personne autre que son destinataire prévu est interdite. Je vous remercie de votre collaboration.

Appendix A

7 - DEVELOPMENT SERVICING STUDY CHECKLIST

Servicing Study Guidelines for Development Applications

4. Development Servicing Study Checklist

4.1 General Content

Required Content	Reference Location
<input type="checkbox"/> Executive Summary (for larger reports only).	N/A
<input checked="" type="checkbox"/> Date and revision number of the report.	Cover Sheet
<input checked="" type="checkbox"/> Location map and plan showing municipal address, boundary, and layout of proposed development.	Report Figures
<input checked="" type="checkbox"/> Plan showing the site and location of all existing services.	Appendix B
<input checked="" type="checkbox"/> Development statistics, land use, density, adherence to zoning and official plan, and reference to applicable subwatershed and watershed plans that provide context to which individual developments must adhere.	Section 1.1
<input checked="" type="checkbox"/> Summary of Pre-consultation Meetings with City and other approval agencies.	Section 1.4
<input checked="" type="checkbox"/> Reference and confirm conformance to higher level studies and reports (Master Servicing Studies, Environmental Assessments, Community Design Plans), or in the case where it is not in conformance, the proponent must provide justification and develop a defensible design criteria.	Section 1.2 & 1.4
<input checked="" type="checkbox"/> Statement of objectives and servicing criteria.	Section 1.0, 2.1, 3.1 & 4.2
<input checked="" type="checkbox"/> Identification of existing and proposed infrastructure available in the immediate area.	Section 1.3 & Appendix B
<input type="checkbox"/> Identification of Environmentally Significant Areas, watercourses and Municipal Drains potentially impacted by the proposed development (Reference can be made to the Natural Heritage Studies, if available).	N/A
<input type="checkbox"/> Concept level master grading plan to confirm existing and proposed grades in the development. This is required to confirm the feasibility of proposed stormwater management and drainage, soil removal and fill constraints, and potential impacts to neighbouring properties. This is also required to confirm that the proposed grading will not impede existing major system flow paths.	N/A
<input type="checkbox"/> Identification of potential impacts of proposed piped services on private services (such as wells and septic fields on adjacent lands) and mitigation required to address potential impacts.	N/A
<input type="checkbox"/> Proposed phasing of the development, if applicable.	N/A
<input type="checkbox"/> Reference to geotechnical studies and recommendations concerning servicing.	N/A
<input type="checkbox"/> All preliminary and formal site plan submissions should have the following information: - Metric scale; - North Arrow (including construction North); - Key Plan; - Name and contact information of applicant and property owner; - Property limits including bearings and dimensions; - Existing and proposed structures and parking areas; - Easements, road widening and rights-of-way; - Adjacent street names.	N/A

4.2 Development Servicing Report: Water

Required Content	Reference Location
<input type="checkbox"/> Confirm consistency with Master Servicing Study, if available	N/A
<input checked="" type="checkbox"/> Availability of public infrastructure to service proposed development	Section 1.3 & Appendix B
<input checked="" type="checkbox"/> Identification of system constraints	Section 2.1 & 2.2
<input checked="" type="checkbox"/> Identify boundary conditions	Section 2.2
<input checked="" type="checkbox"/> Confirmation of adequate domestic supply and pressure	Section 2.2 & 2.3
<input checked="" type="checkbox"/> Confirmation of adequate fire flow protection and confirmation that fire flow is calculated as per the Fire Underwriter's Survey. Output should show available fire flow at locations throughout the development.	Section 2.2 & 2.3
<input type="checkbox"/> Provide a check of high pressures. If pressure is found to be high, an assessment is required to confirm the application of pressure reducing valves.	N/A
<input type="checkbox"/> Definition of phasing constraints. Hydraulic modeling is required to confirm servicing for all defined phases of the project including the ultimate design	N/A
<input checked="" type="checkbox"/> Address reliability requirements such as appropriate location of shut-off valves	Section 2.2 & Appendix C
<input type="checkbox"/> Check on the necessity of a pressure zone boundary modification.	N/A
<input checked="" type="checkbox"/> Reference to water supply analysis to show that major infrastructure is capable of delivering sufficient water for the proposed land use. This includes data that shows that the expected demands under average day, peak hour and fire flow conditions provide water within the required pressure range	Table 2-4

Servicing Study Guidelines for Development Applications

<input type="checkbox"/>	Description of the proposed water distribution network, including locations of proposed connections to the existing system, provisions for necessary looping, and appurtenances (valves, pressure reducing valves, valve chambers, and fire hydrants) including special metering provisions.	N/A
<input type="checkbox"/>	Description of off-site required feeder mains, booster pumping stations, and other water infrastructure that will be ultimately required to service proposed development, including financing, interim facilities, and timing of implementation.	N/A
<input checked="" type="checkbox"/>	Confirmation that water demands are calculated based on the City of Ottawa Design Guidelines.	Section 2.3
<input type="checkbox"/>	Provision of a model schematic showing the boundary conditions locations, streets, parcels, and building locations for reference.	N/A

4.3 Development Servicing Report: Wastewater

Required Content	Reference Location
<input checked="" type="checkbox"/> Summary of proposed design criteria (Note: Wet-weather flow criteria should not deviate from the City of Ottawa Sewer Design Guidelines. Monitored flow data from relatively new infrastructure cannot be used to justify capacity requirements for proposed infrastructure).	Section 3.1
<input type="checkbox"/> Confirm consistency with Master Servicing Study and/or justifications for deviations.	N/A
<input checked="" type="checkbox"/> Consideration of local conditions that may contribute to extraneous flows that are higher than the recommended flows in the guidelines. This includes groundwater and soil conditions, and age and condition of sewers.	Section 3.3, Appendix A & Appendix E
<input checked="" type="checkbox"/> Description of existing sanitary sewer available for discharge of wastewater from proposed development	Section 1.3, 3.2 & Appendix B
<input checked="" type="checkbox"/> Verify available capacity in downstream sanitary sewer and/or identification of upgrades necessary to service the proposed development. (Reference can be made to previously completed Master Servicing Study if applicable)	Section 3.3
<input checked="" type="checkbox"/> Calculations related to dry-weather and wet-weather flow rates from the development in standard MOE sanitary sewer design table (Appendix 'C') format.	Section 3.2 & Appendix E
<input checked="" type="checkbox"/> Description of proposed sewer network including sewers, pumping stations, and forcemains.	Section 3.2
<input type="checkbox"/> Discussion of previously identified environmental constraints and impact on servicing (environmental constraints are related to limitations imposed on the development in order to preserve the physical condition of watercourses, vegetation, soil cover, as well as protecting against water quantity and quality).	N/A
<input type="checkbox"/> Pumping stations: impacts of proposed development on existing pumping stations or requirements for new pumping station to service development.	N/A
<input type="checkbox"/> Forcemain capacity in terms of operational redundancy, surge pressure and maximum flow velocity.	N/A
<input type="checkbox"/> Identification and implementation of the emergency overflow from sanitary pumping stations in relation to the hydraulic grade line to protect against basement flooding.	N/A
<input type="checkbox"/> Special considerations such as contamination, corrosive environment etc.	N/A

4.4 Development Servicing Report: Stormwater Checklist

Required Content	Reference Location
<input checked="" type="checkbox"/> Description of drainage outlets and downstream constraints including legality of outlets (i.e. municipal drain, right-of-way, watercourse, or private property)	Section 4.1
<input checked="" type="checkbox"/> Analysis of available capacity in existing public infrastructure.	Section 4.1
<input checked="" type="checkbox"/> A drawing showing the subject lands, its surroundings, the receiving watercourse, existing drainage patterns, and proposed drainage pattern.	Appendix C & F
<input checked="" type="checkbox"/> Water quantity control objective (e.g. controlling post-development peak flows to pre-development level for storm events ranging from the 2 or 5 year event (dependent on the receiving sewer design) to 100 year return period); if other objectives are being applied, a rationale must be included with reference to hydrologic analyses of the potentially affected subwatersheds, taking into account long-term cumulative effects.	Section 4.2
<input checked="" type="checkbox"/> Water Quality control objective (basic, normal or enhanced level of protection based on the sensitivities of the receiving watercourse) and storage requirements.	Section 4.2
<input checked="" type="checkbox"/> Description of the stormwater management concept with facility locations and descriptions with references and supporting information.	Section 4.3, 4.4 & Appendix C
<input type="checkbox"/> Set-back from private sewage disposal systems.	N/A
<input type="checkbox"/> Watercourse and hazard lands setbacks.	N/A
<input checked="" type="checkbox"/> Record of pre-consultation with the Ontario Ministry of Environment and the Conservation Authority that has jurisdiction on the affected watershed.	Appendix A
<input type="checkbox"/> Confirm consistency with sub-watershed and Master Servicing Study, if applicable study exists.	N/A

Servicing Study Guidelines for Development Applications

<input checked="" type="checkbox"/>	Storage requirements (complete with calculations) and conveyance capacity for minor events (1:5 year return period) and major events (1:100 year return period).	Section 4.3 & Appendix F
<input type="checkbox"/>	Identification of watercourses within the proposed development and how watercourses will be protected, or, if necessary, altered by the proposed development with applicable approvals.	N/A
<input checked="" type="checkbox"/>	Calculate pre and post development peak flow rates including a description of existing site conditions and proposed impervious areas and drainage catchments in comparison to existing conditions.	Section 4.1, 4.3 & Appendix F
<input type="checkbox"/>	Any proposed diversion of drainage catchment areas from one outlet to another.	N/A
<input type="checkbox"/>	Proposed minor and major systems including locations and sizes of stormwater trunk sewers, and stormwater management facilities.	N/A
<input type="checkbox"/>	If quantity control is not proposed, demonstration that downstream system has adequate capacity for the post-development flows up to and including the 100 year return period storm event.	N/A
<input type="checkbox"/>	Identification of potential impacts to receiving watercourses	N/A
<input type="checkbox"/>	Identification of municipal drains and related approval requirements.	N/A
<input checked="" type="checkbox"/>	Descriptions of how the conveyance and storage capacity will be achieved for the development.	Section 4.3 and 4.4
<input type="checkbox"/>	100 year flood levels and major flow routing to protect proposed development from flooding for establishing minimum building elevations (MBE) and overall grading.	N/A
<input type="checkbox"/>	Inclusion of hydraulic analysis including hydraulic grade line elevations.	N/A
<input type="checkbox"/>	Description of approach to erosion and sediment control during construction for the protection of receiving watercourse or drainage corridors.	N/A
<input type="checkbox"/>	Identification of floodplains – proponent to obtain relevant floodplain information from the appropriate Conservation Authority. The proponent may be required to delineate floodplain elevations to the satisfaction of the Conservation Authority if such information is not available or if information does not match current conditions.	N/A
<input type="checkbox"/>	Identification of fill constraints related to floodplain and geotechnical investigation.	N/A

4.5 Approval and Permit Requirements: Checklist

Required Content	Reference Location
<input type="checkbox"/> Conservation Authority as the designated approval agency for modification of floodplain, potential impact on fish habitat, proposed works in or adjacent to a watercourse, cut/fill permits and Approval under Lakes and Rivers Improvement Act. The Conservation Authority is not the approval authority for the Lakes and Rivers Improvement Act. Where there are Conservation Authority regulations in place, approval under the Lakes and Rivers Improvement Act is not required, except in cases of dams as defined in the Act.	N/A
<input type="checkbox"/> Application for Certificate of Approval (CofA) under the Ontario Water Resources Act.	N/A
<input type="checkbox"/> Changes to Municipal Drains.	N/A
<input type="checkbox"/> Other permits (National Capital Commission, Parks Canada, Public Works and Government Services Canada, Ministry of Transportation etc.)	N/A

4.6 Conclusion Checklist

Required Content	Reference Location
<input checked="" type="checkbox"/> Clearly stated conclusions and recommendations	Section 5.0
<input type="checkbox"/> Comments received from review agencies including the City of Ottawa and information on how the comments were addressed. Final sign-off from the responsible reviewing agency.	N/A
<input checked="" type="checkbox"/> All draft and final reports shall be signed and stamped by a professional Engineer registered in Ontario	Cover Sheet

B

Appendix B Existing Conditions Plan



TOPOGRAPHIC SURVEY OF
OF LOTS 14 & 15 AND
PART OF LOTS 13 & 16
(SOUTH OF STINE BOUNDARY LOTS)
EAST OF BELL STREET NORTH
REGISTERED PLAN 33

CITY OF OTTAWA



Stantec Geomatics Ltd.
ONTARIO LAND SURVEYORS

BEARING NOTE
BEARINGS ARE GRID, DERIVED FROM THE CAN-NEI VRS NETWORK OBSERVATIONS ON NCC HORIZONTAL CONTROL MONUMENTS 19773035 AND 19680191, CENTRAL MERIDIAN, 76°30' WEST LONGITUDE MTM ZONE 9, NAD83 (ORIGINAL) (2010.0).

19773035 N:500460.00 E:324888.04
19680191 N:5033563.88 E:388064.92

ELEVATION NOTE
ELEVATIONS SHOWN HEREON ARE GEODETIC (CGVD:1928-1978) AND ARE DERIVED FROM THE CAN-NEI VRS NETWORK MONUMENT, OTTAWA ELEVATION=95.230.

METRIC CONVERSION
DISTANCES AND COORDINATES SHOWN ON THIS PLAN ARE IN METRES AND CAN BE CONVERTED TO FEET BY DIVIDING BY 0.3048

ROTATION NOTE
BEARINGS ARE GRID AND A 0°35'00" ANGLE HAS BEEN APPLIED COUNTERCLOCKWISE TO PLANS P1 AND P2.

LEGEND	DENOTES	FOUND MONUMENTS
■	SET MONUMENTS	
IB	IRON BAR	
IBK	ROUND IRON BAR	
SIB	STANDARD IRON BAR	
SSIB	SHORT STANDARD IRON BAR	
CC	CUT CROSS	
CP	CONCRETE PIN	
WIT	WITNESS	
PIN	PROPERTY IDENTIFICATION NUMBER	
M/MEAS	MEASURED	
PROP	PROPORTIONED	
OU	ORIGIN UNKNOWN	
STANTEC	STANTEC GEOMATICS LTD.	
P1	PLAN BY FAIRHALL, MOFFATT & WOODLAND, DATED FEBRUARY 2ND, 1995	
P2	PLAN BY ANNIS O'SULLIVAN VOLLEBECK, DATED APRIL 19TH, 2021	
R.W.	ARNETT O.L.S.	
CITY	CITY OF OTTAWA	
FMW	FAIRHALL, MOFFATT AND WOODLAND O.L.S.	
AN	ANCHOR	
BOL	BOLLARD	
CB	CATCH BASIN	
SCB	SIDE INLET CB	
CSR	GAS SERVICE REGULATOR	
MHSAN	MAINTENANCE HOLE SANITARY	
SW	SIGN	
WV	WATER VALVE	

GASMAIN — G — G — G —
OVERHEAD WIRE — OHW —

SURVEYOR'S CERTIFICATE
I CERTIFY THAT:
1. THE SURVEY WAS COMPLETED ON THE 30th DAY OF MAY, 2022.

DATE _____ R. G. BENNETT
ONTARIO LAND SURVEYOR
THIS PLAN OF SURVEY RELATES TO AOLS PLAN SUBMISSION FORM NUMBER V-28656.

DRAWN: RG CHECKED: GB PM: CT FIELD: CA PROJECT No.: 161614574-111

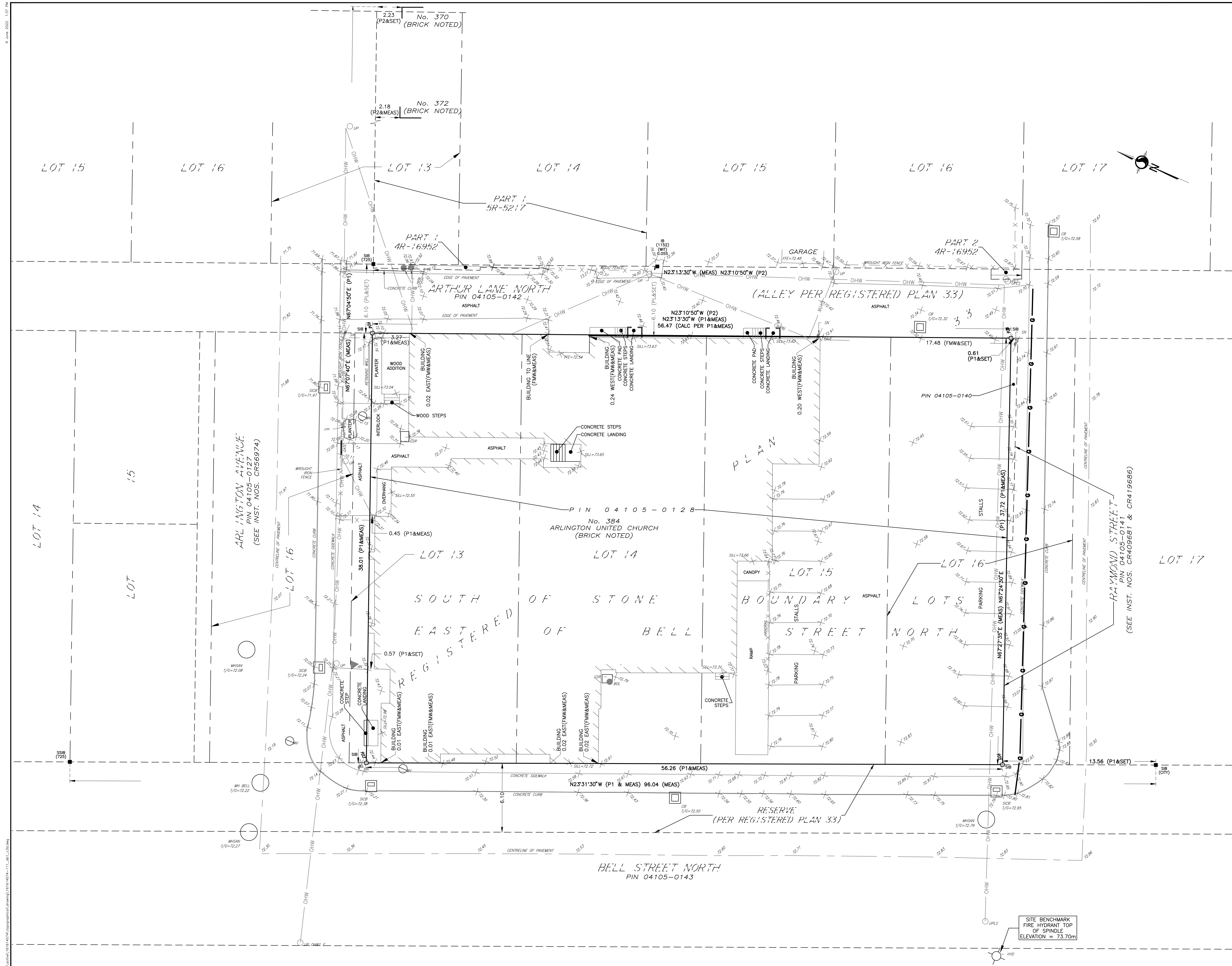

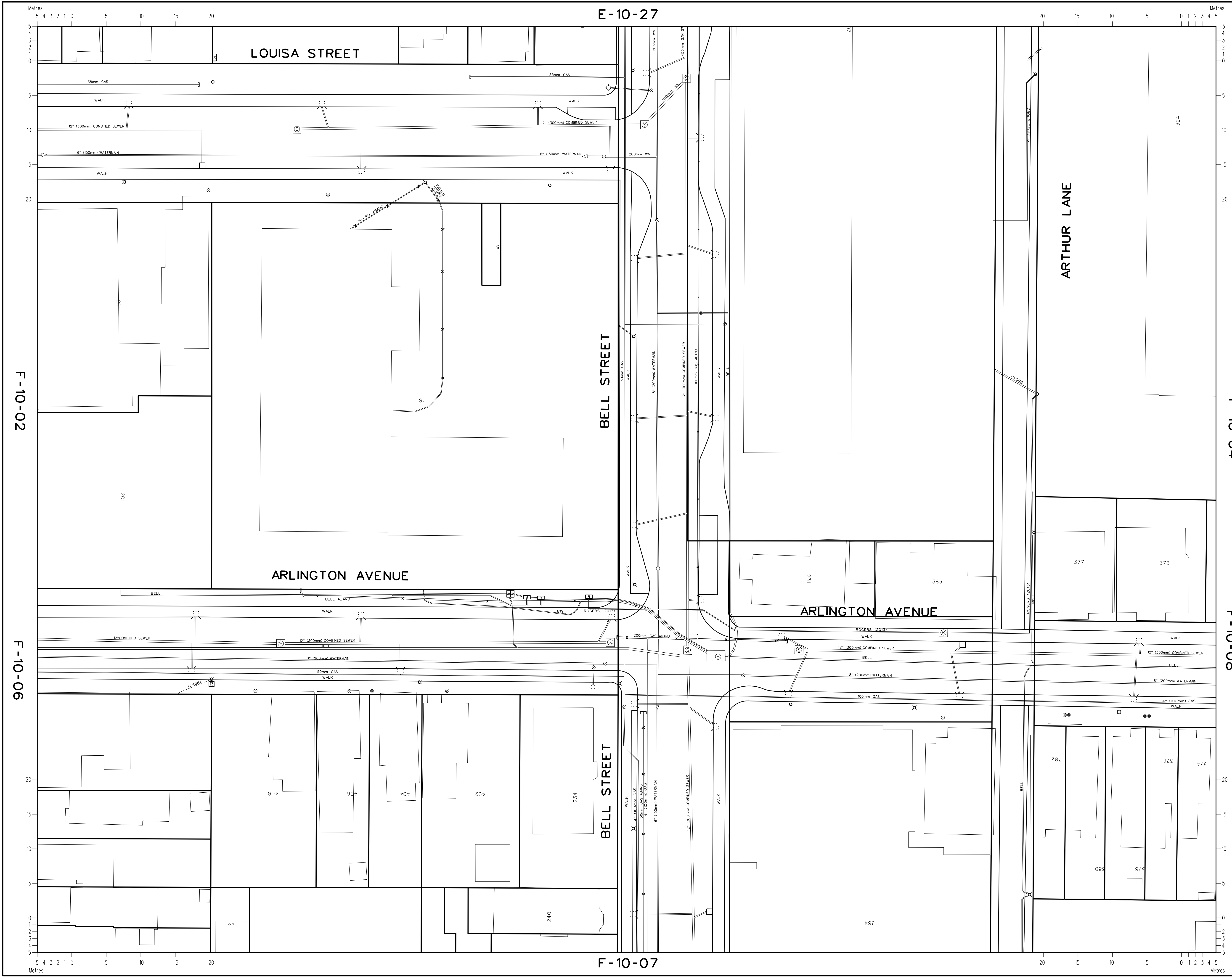

REVISIONS / RÉVISIONS	DATE	BY
3335 - LOUISA (Rev. to 04, DEC 2003)	SEPT. 04	DC
SEWER, WATER, ROAD REV ON LOUISA	SEPT. 04	DC
3335 - ARLINGTON (Rev. to 04, DEC 2003)	SEPT. 04	DC
SEWER, WATER, ROAD REV ON ARLINGTON	SEPT. 04	DC
REVISION BEL05048 SEPT 2008	MAR 2010	AJ
BELL ADDED TO ARLINGTON AND BELL ST	MAR 2010	AJ
ROGERS (2010) MAR 2010	NOV 2016	JM
PANEL/CONDUIT ADDED TO ARLINGTON	NOV 2016	JM
BEL043-BELL (FEB 2010)	NOV 2016	JM
ONU/CONDUIT ADDED TO ARLINGTON	NOV 2016	JM
BEL044-BELL (FEB 2010)	NOV 2016	JM
ONU/CONDUIT ADDED TO ARLINGTON	NOV 2016	JM
ROGERS (2010) NOV 2016	NOV 2016	JM
MV/CONDUIT ADDED TO ARLINGTON, ARTHUR	NOV 2016	JM
CITY, ALL EXTERNAL AGENCIES	JUN 2022	DC
DIGITIZED FROM CITY/UTILITY DATA RECEIVED		

LEGEND

Water Valve, Valve Chamber, Fire Hydrant	
Sewer Manhole, Catch Basin Manhole	
Catch Basin / Drainage, Wing Wall, Head Wall	
Pole, Pole w/ light, Decorative, Lawn Light	
Power Supply, Panel, Pedestal, Transformer, Tower, Regulator	
Amp, Hand Hole, Vault, Gas Valve	
OC Transpo: Bus Shelter-No Power, Energized, Isolated	
Streetscape: Planter Box, Grate Square, Eng. Soil	
Traffic Connect Box / Disconnect Box, SL Disconnect	
Red Light Hand Hole, Red Light Camera	
Scada: Hand Hole, Monitoring Panel	
Reducer	
Pipe, Duct, Conduit, Lateral	
Culvert	
Ditch	
Abandoned	
Capped	
Buried Cable	
Property Line	
Install Year	

(2015)

TELECOM GLOSSARY

A.....Allstream	P.....Primus
AT.....Atria	P2P.....Canadian P2P Fibre
B.....Bell	R.....Rogers
BH.....Birch Hill	S.....Sprint
F.....Fibre Noir	SL.....Street Lighting
G.....Globleity	T.....Traffic
GT.....Group Telecom	TO.....Telecom Ottawa
H.....Hydro Ottawa	TU.....Telus
HT.....Hydro One	V.....Videotron
L/L3.....Level 3	Z.....Zayo

GLOSSARY - OTHER

DD.....Dept. of Defence	PED.....Pedestal (owner unknown)
MH.....Manhole (owner unknown)	PIW.....Public Works
OIOC.....OC Transpo	UP.....Utility Pole (owner unknown)
SCD.....Scada	

CAUTION/ATTENTION

Although utility locations are established using the best available information, they cannot be guaranteed. Property lines were compiled from plans and documents recorded in the Land Registry System and are for indexing purposes only.

Bien que l'emplacement des services publics soient établis en utilisant la meilleure information disponible, ils ne peuvent pas être garantis. Des lignes de propriété ont été compilées en utilisant des plans et des documents enregistrés dans le système de cadastre et sont pour l'indexation seulement.



OTTAWA UTILITY COORDINATING COMMITTEE
CENTRAL REGISTRY
COMITÉ DE COORDINATION DES SERVICES PUBLICS D'OTTAWA
ENREGISTREMENT CENTRAL

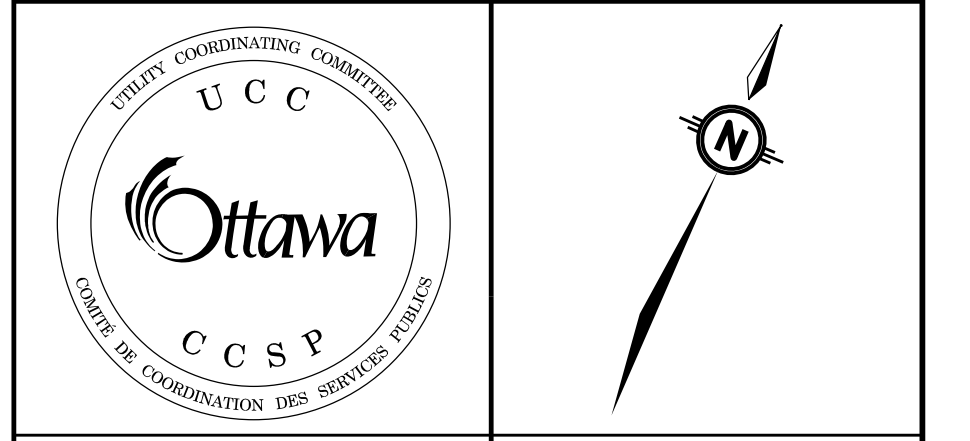

PRODUCED BY: GIS & DATA MANAGEMENT BRANCH
INFORMATION CENTRE UNIT

SHEET NUMBER
F-10-03

SCALE: 1:250

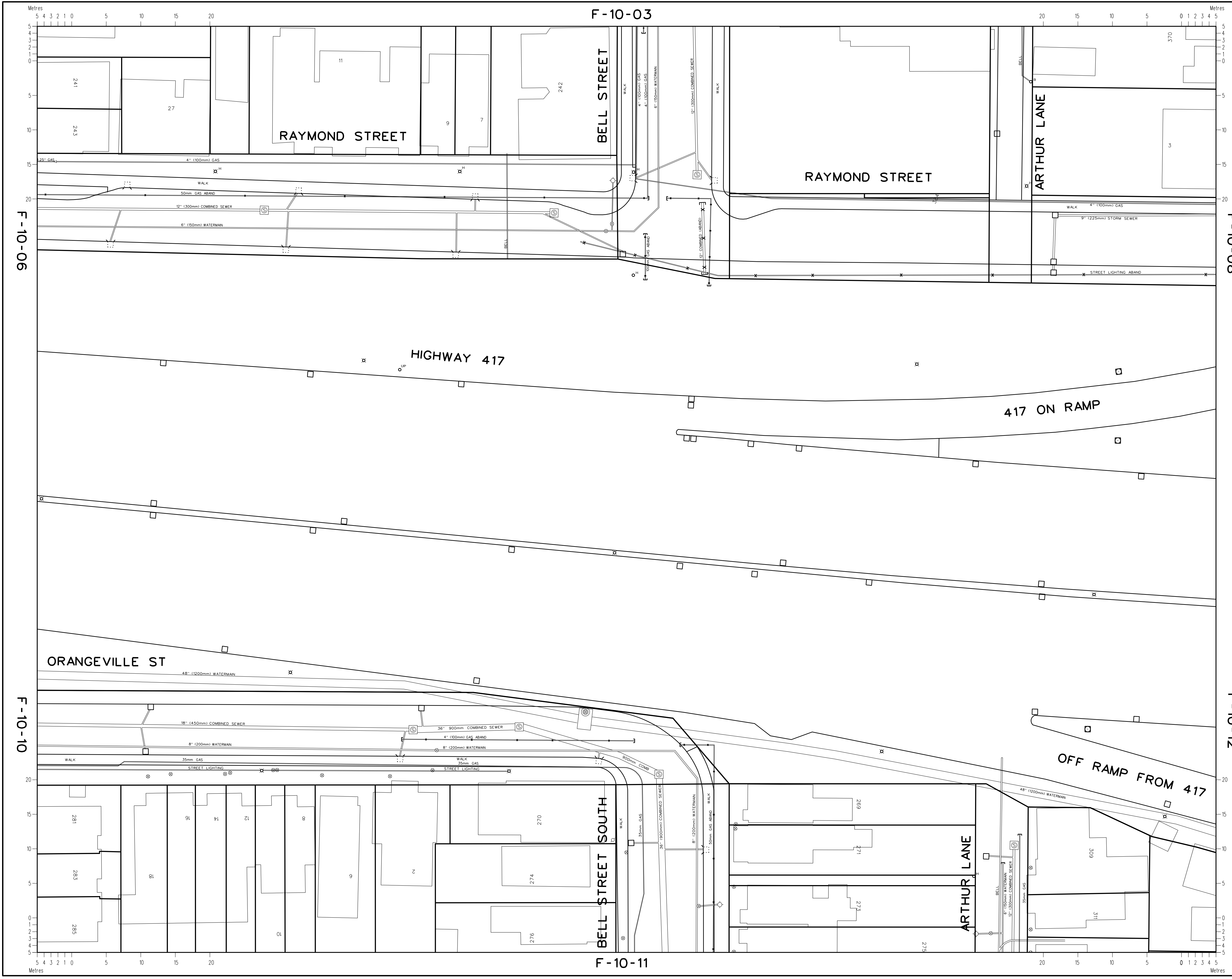

REVISIONS / RÉVISIONS	DATE	BY
2907 - BELL S. (Copying to Orangeville, JUNE 1997)		
SEWER, WATER, ROAD REVISED ON BELL	SEPT. 04	DC
3335 - BELL N. (Orangeville - Raymond, DEC. 2003)		
SEWER, WATER, ROAD REVISED ON BELL N.	SEPT. 04	DC
3335 - RAYMOND (Booth to Cambridge N., DEC. 2003)		
SEWER, WATER, ROAD REV ON RAYMOND	SEPT. 04	DC
CITY, ALL EXTERNAL AGENCIES		
DIGITIZED FROM CITY/UTILITY DATA RECEIVED	JUN 2022	DC

LEGEND	
Water Valve, Valve Chamber, Fire Hydrant	
Sewer Manhole, Catch Basin Manhole	
Catch Basin / Drainage, Wing Wall, Head Wall	
Pole, Pole w/ light, Decorative, Lawn Light	
Power Supply, Panel, Pedestal, Transformer, Tower, Regulator	
Amp, Hand Hole, Vault, Gas Valve	
OC Transpo: Bus Shelter-No Power, Energized, Isolated	
Streetscape: Planter Box, Grate Square, Eng. Soil	
Traffic Connect Box / Disconnect Box, SL Disconnect	
Red Light Hand Hole, Red Light Camera	
Scada: Hand Hole, Monitoring Panel	
Reducer	
Pipe, Duct, Conduit, Lateral	
Culvert	
Ditch	
Abandoned	
Capped	
Buried Cable	
Property Line	
Install Year	(2015)

TELECOM GLOSSARY	
A.....Allstream	P.....Primus
AT.....Atria	PPP.....Canadian P2P Fibre
B.....Bell	R.....Rogers
BH.....Birch Hill	S.....Sprint
F.....Fibre Noir	SL.....Street Lighting
G.....Globeity	T.....Traffic
GT.....Group Telecom	TO.....Telecom Ottawa
H.....Hydro Ottawa	TU.....Telus
HT.....Hydro One	V.....Videotron
L/L3.....Level 3	Z.....Zayo

GLOSSARY - OTHER	
DD.....Dept. of Defence	PED.....Pedestal (owner unknown)
MH.....Manhole (owner unknown)	PW.....Public Works
OIOC.....OCTranspo	UP.....Utility Pole (owner unknown)
SCD.....Scada	

CAUTION/ATTENTION
 Although utility locations are established using the best available information, they cannot be guaranteed.
 Property lines were compiled from plans and documents recorded in the Land Registry System and are for indexing purposes only.
 Bien que l'emplacement des services publics soient établis en utilisant la meilleure information disponible, ils ne peuvent pas être garantis.
 Des lignes de propriété ont été compilées en utilisant des plans et des documents enregistrés dans le système de cadastre et sont pour l'indexation seulement.

Ottawa
 Right of Way, Heritage, and Urban Design Services /
 Gestionnaire, Services des emprises, du patrimoine, et du design urbain
 Planning, Infrastructure and Economic Development Department /
 Direction générale de la planification, de l'infrastructure et du développement économique
 100 Constellation Cres., 6th Floor East / 6ème Étage Est, Ottawa, ON K2G 6J8

OTTAWA UTILITY COORDINATING COMMITTEE
 CENTRAL REGISTRY
 COMITÉ DE COORDINATION DES SERVICES PUBLICS D'OTTAWA
 ENREGISTREMENT CENTRAL

Ottawa
 UCC
 CCSP
 COORDINATION DES SERVICES PUBLICS D'OTTAWA

C

Appendix C Detailed Design Civil Plans



D

Appendix D Water Supply Design Calculations



PROJECT NAME: Redevelopment of 384 Arlington Ave
CIMA+ PROJECT NUMBER: A001272
CLIENT: Windmill Development Group Ltd.
PROJECT STATUS: Site Servicing and Stormwater Management Report

FIRE FLOW ASSESSMENT

APPLICABLE DESIGN GUIDELINES:

1. Fire Underwriters Survey (FUS) Water Supply for Public Fire Protection, 2020
2. Ottawa Design Guidelines - Water Distribution (2010) including Appendix H per ISTB-2018-02
3. City of Ottawa Technical Bulletin ISTB-2021-03 and ISTB-2018-02
4. MOE Design Guidelines for Drinking-Water Systems

STEP A - DETERMINE THE TYPE OF CONSTRUCTION

Type of Construction	Coefficient (C)	Value Selected (C)
Fire-resistive Construction (> 2 hours)	0.6	0.8
Non-combustible Construction	0.8	
Ordinary Construction	1.0	
Wood Frame Construction	1.5	

STEP B - DETERMINE THE FLOOR AREA

Floor/Level	Floor Area Per Level (sq. ft.)	Floor Area Per Level (m ²)	Fire Resistive Building	Protected Openings (one hour rating)	Area of Structure Considered (m ²)
Gross Construction Area (GCA) Ground Level:	16,867	1,567	YES	YES	1,567
GCA Level 2:	16,124	1,498			-
GCA Level 3:	16,103	1,496			-
GCA Level 4:	14,833	1,378			-
GCA Level 5:	11,604	1,078			-
GCA Level 6:	11,582	1,076			-
GCA Level 7:	11,302	1,050			-
GCA Level 8:	8,514	791			-
GCA Level 9:	8,514	791			-
GCA Level 10:	8,514	791			-
GCA Level 11:	8,514	791			-
GCA Level 12:	8,514	791			-
GCA Level 13:	8,514	791			-
GCA Level 14:	8,514	791			-
GCA Level 15:	8,514	791			-
GCA Level 16:	8,514	791			-
GCA Level 17:	8,514	791			-
GCA Level 18:	8,514	791			-
GCA Level 19:	8,514	791			-
GCA Level 20:	8,514	791			-
GCA Level 21:	8,514	791			-
GCA Level 22:	8,514	791			-
GCA Level 23:	8,514	791			-
GCA Level 24:	8,514	791			-
TOTAL FLOOR AREA (A):	243,157	22,589			



PROJECT NAME: Redevelopment of 384 Arlington Ave
CIMA+ PROJECT NUMBER: A001272
CLIENT: Windmill Development Group Ltd.
PROJECT STATUS: Site Servicing and Stormwater Management Report

FIRE FLOW ASSESSMENT

STEP C - DETERMINE THE HEIGHT IN STOREYS

Floor/Level	Number of Storeys	Percent of Floor Area Considered
Ground Level:	1	100%
Level 2:	1	100%
Level 3:	1	50%
Level 4:	1	50%
Level 5:	1	50%
Level 6:	1	50%
Level 7:	1	50%
Level 8:	1	50%
Level 9:	1	50%
Level 10:	1	50%
Level 11:	1	-
Level 12:	1	-
Level 13:	1	-
Level 14:	1	-
Level 15:	1	-
Level 16:	1	-
Level 17:	1	-
Level 18:	1	-
Level 19:	1	-
Level 20:	1	-
Level 21:	1	-
Level 22:	1	-
Level 23:	1	-
Level 24:	1	-
HEIGHT IN STOREYS:	24	

STEP D - DETERMINE BASE FIRE FLOW (ROUND TO NEAREST 1,000 L/min)

$$F = 220C\sqrt{A}$$

Where:

- F is the required fire flow in L/min
- C is the coefficient related to the type of construction, and;
- A is the total floor area of the building in m²

Coefficient Related to Type of Construction (C) = 0.8
Floor Area Considered (A) = 7,290 m²

REQUIRED (BASE) FIRE FLOW (F) = 15,000 L/min (Rounded to Nearest 1,000 L/min)

STEP E - DETERMINE THE INCREASE OR DECREASE FOR OCCUPANCY AND APPLY TO STEP D (STEP D x STEP E, DO NOT ROUND)

Occupancy Class	Occupancy Factor	Value Selected (C)
Non-combustible	0.75	1.00
Limited combustible	0.85	
Combustible	1.00	
Free burning	1.15	
Rapid burning	1.25	

REQUIRED (BASE) FIRE FLOW (F) = 15,000 L/min (Not rounded)



PROJECT NAME: Redevelopment of 384 Arlington Ave
CIMA+ PROJECT NUMBER: A001272
CLIENT: Windmill Development Group Ltd.
PROJECT STATUS: Site Servicing and Stormwater Management Report

FIRE FLOW ASSESSMENT

STEP F - DETERMINE THE DECREASE, IF ANY, FOR AUTOMATIC SPRINKLER PROTECTION AND APPLY TO VALUE IN STEP D ABOVE (DO NOT ROUND)

Sprinkler System Design	Sprinkler Design Charge	Value Selected (C)	Total Charge
Automatic sprinkler system conforming to NFPA standards	-30%	Yes	-30%
Standard water supply	-10%	Yes	-10%
Fully supervised system	-10%	No	0%
TOTAL CHARGE FOR SPRINKLER SYSTEM			-40%

DECREASE FOR SPRINKLER PROTECTION = -6,000 L/min (Not rounded)

STEP G - DETERMINE THE TOTAL INCREASE FOR EXPOSURES AND APPLY TO VALUE IN STEP D ABOVE (DO NOT ROUND)

Façade	Separation Distance (m)	Length-height Factor of Exposed Wall (m-storeys)	Assumed Construction of Exposed Wall of Adjacent	Total Charge
North Façade	16.0	54	Ordinary with Unprotected Openings	7%
East Façade	8.1	33	Ordinary with Unprotected Openings	11%
South Façade	>30	0	N/A	0%
West Façade	21.0	84	Ordinary with Unprotected Openings	4%
TOTAL CHARGE FOR EXPOSURES				22%

INCREASE FOR EXPOSURES = 3,300 L/min (Not rounded)

STEP H - DETERMINE FIRE FLOW INCLUDING ALL INCREASES AND REDUCTIONS ((STEP E + STEP F + STEP G, ROUND TO NEAREST 1,000 L/min)

TOTAL REQUIRED FIRE FLOW (RFF) = 12,000 L/min (Rounded to Nearest 1,000 L/min)
200.00 L/s
3,170 USGPM



CIMA+

T: 613-860-2462
600-1400 Blair Towers Place, Ottawa, ON K1J 9B8 CANADA

EXPOSURE SEPARATIONS DISTANCES

DRAWN & DESIGNED BY: M. Frechette	APPROVED BY: E. Potvin	SCALE: NTS	DATE:	PROJECT No: A001272	SHEET No: 1 of 1	FIGURE No: 001
--------------------------------------	---------------------------	---------------	-------	------------------------	---------------------	-------------------



CIMA+

T: 613-860-2462
600-1400 Blair Towers Place, Ottawa, ON K1J 9B8 CANADA

FIRE HYDRANT COVERAGE

DRAWN & DESIGNED BY:
M. Frechette

APPROVED BY:
E. Potvin

SCALE:
NTS

DATE:

PROJECT No:
A001272

SHEET No:
1 of 1

FIGURE No:
002

E

Appendix E Sanitary Servicing Design Calculations



PROJECT NAME: Redevelopment of 384 Arlington Ave
CIMA+ PROJECT NUMBER: A001272
CLIENT: Windmill Development Group Ltd.
PROJECT STATUS: Site Servicing and Stormwater Management Report

WASTEWATER PEAK FLOW DETERMINATION

APPLICABLE DESIGN GUIDELINES:

1. City of Ottawa Sewer Design Guidelines, 2012
2. City of Ottawa Technical Bulletin ISTB-2018-01

DOMESTIC CONTRIBUTIONS:

RESIDENTIAL DESIGN CRITERIA:

Residential Average Flow: (1)
 Residential Peak Factor (P.F.):

280 L/c/day
 Harmon Equation (Min 2.0 and Max 4.0)

$$P.F. = 1 + \frac{14}{4 + \left(\frac{P}{1000}\right)^{\frac{1}{2}}} * K$$

where:
 P=Population
 K=Correction Factor =0.8

Per Unit Populations:

Unit Type	Persons Per Unit
Single Family	3.4
Semi-detached	2.7
Duplex	2.3
Townhouse (row)	2.7
Apartments:	
Bachelor	1.4
1 Bedroom	1.4
2 Bedroom	2.1
3 Bedroom	3.1
Average Apt.	1.8

AVERAGE FLOW - DOMESTIC:

Unit Type	Number of Units	Persons Per Unit	Population	Average Flow (L/s)
Bachelor Apartments	26	1.4	36	0.12
1-Bedroom Apartments	155	1.4	217	0.70
1-Bedroom + Den Apartments	7	1.4	10	0.03
2-Bedroom Apartments	106	2.1	223	0.72
2-Bedroom + Den Apartments	0	2.1	0	0.00
3-Bedroom Apartments	2	3.1	6	0.02
Total	296		492	1.59

PEAK FLOW - DOMESTIC:

Population: (2) 492 persons
 Average Dry Weather Flow: (3) = (1) x (2) 1.59 L/s
 Peaking Factor (P.F.): (4) 3.38
Peak Domestic Flow: (5) = (3) x (4) 5.37 L/s

COMMERCIAL & INSTITUTIONAL CONTRIBUTIONS:

COMMERCIAL AND INSTITUTIONAL DESIGN CRITERIA:

Commercial Average Flow: (6) 28 000 L/gross ha/d
 Commercial Peak Factor: 1.5 if commercial contribution >20%, otherwise use 1.0

AVERAGE FLOW - COMMERCIAL:

Contributing Commercial Area: (7) 0.0942 gross ha (including activities room, gym and yoga)
 Average Dry Weather Flow: (8) = (6) x (7) 0.03 L/s

PEAK FLOW - COMMERCIAL:

Percent Commercial Area Contribution: 4% (GFA/Commercial Floor Area)
 Peaking Factor: (9) 1.00

Peak Commercial Flow: (10) = (8) x (9) 0.03 L/s

EXTRANEOUS FLOW CONTRIBUTION - INFLOW AND INFILTRATION:

EXTRANEOUS DESIGN CRITERIA:

Dry Weather Infiltration: 0.05 L/s/effective gross ha (for all areas)
 Wet Weather Infiltration: 0.28 L/s/effective gross ha (for all areas)

PEAK FLOW - EXTRANEOUS:

Effective Gross Area: (11) 0.22 ha
 Total Infiltration Allowance: (12) 0.33 L/s/effective gross ha (for all areas)

Peak Extraneous Flow: (13) = (11) x (12) 0.07 L/s



PROJECT NAME: Redevelopment of 384 Arlington Ave
CIMA+ PROJECT NUMBER: A001272
CLIENT: Windmill Development Group Ltd.
PROJECT STATUS: Site Servicing and Stormwater Management Report

WASTEWATER PEAK FLOW DETERMINATION

Total Estimated Avg. Dry Weather Flow Rate:	1.62	L/s
Total Estimated Peak Dry Weather Flow Rate:	5.40	L/s
Total Estimated Peak Wet Weather Flow Rate:	5.48	L/s

Prepared by: Martin Frechette, EIT

Date: 2025-01-23

Verified by: Éric Potvin, P.Eng.
PEO# 100208490

Date: 2025-06-19

F

Appendix F Storm Servicing and Stormwater Management Calculations



PROJECT NAME: Redevelopment of 384 Arlington Ave
CIMA+ PROJECT NUMBER: A001272
CLIENT: Windmill Development Group Ltd.
PROJECT STATUS: Site Servicing and Stormwater Management Report

STORM RUNOFF COEFFICIENT DETERMINATION (PRE-DEVELOPMENT)

APPLICABLE DESIGN GUIDELINES:

- 1. City of Ottawa Sewer Design Guidelines, 2012

PRE-DEVELOPMENT RUNOFF COEFFICIENT DETERMINATION:

Area	Pervious Area m ²	Pervious Area Runoff Coefficient	Impervious Area m ²	Impervious Area Runoff Coefficient	Total Area m ²	Weighted Runoff Coefficient (2-year)	Weighted Runoff Coefficient (100-year)
A1	12	0.20	2121	0.90	2133	0.90	1.00
TOTAL	12	0.20	2121	0.90	2133	0.90	1.00

NOTES:

For 25 year storms add 10% to C value
 For 50 year storms add 20% to C value
 For 100 year storms add 25% to C value

Prepared by: Jaymeson Adams, P.Eng.
PEO# 100519478

Date: 2022-07-07

Verified by: Tim Kennedy, P.Eng.
PEO# 100173201

Date: 2022-07-21



PROJECT NAME: Redevelopment of 384 Arlington Ave
CIMA+ PROJECT NUMBER: A001273
CLIENT: Windmill Development Group Ltd.
PROJECT STATUS: Site Servicing and Stormwater Management Report

STORM PRE-DEVELOPMENT FLOW - EXISTING SITE FLOWS

APPLICABLE DESIGN GUIDELINES:

1. City of Ottawa Sewer Design Guidelines, 2012

PRE-DEVELOPMENT FLOW DETERMINATION - 2-YEAR EVENT:

DESIGN CRITERIA:

Design Storm (year):	2	
IDF Regression Constants: (a)	732.951	
(b)	6.199	
(c)	0.810	
IDF Curve Equation (mm/hr):	$I = a / (\text{Time in min} + b)^c$	
Rational Formula (L/s):	$Q = 2.78C \cdot I \cdot A$	where: Q = Flow (L/s) C = Runoff Coefficient I = Rainfall Intensity (mm/hr) A = Area (hectares)

EXISTING RELEASE RATE - SUMMARY:

Catchment ID	Area (A) ha	Runoff Coefficient (C)	Time of Concentration (tc) min	Intensity (I) mm/hr	Release Rate (Q) L/s	Release Flow Per Unit Area (Q/ha) L/s/ha
Subject Site	0.213	0.90	10	76.81	40.96	192.01

PRE-DEVELOPMENT FLOW DETERMINATION - 5-YEAR EVENT:

DESIGN CRITERIA:

Design Storm (year):	5	
IDF Regression Constants: (a)	998.071	
(b)	6.053	
(c)	0.814	

EXISTING RELEASE RATE - SUMMARY:

Catchment ID	Area (A) ha	Runoff Coefficient (C)	Time of Concentration (tc) min	Intensity (I) mm/hr	Release Rate (Q) L/s	Release Flow Per Unit Area (Q/ha) L/s/ha
Subject Site	0.213	0.90	10	104.19	55.56	260.48

PRE-DEVELOPMENT FLOW DETERMINATION - 100-YEAR EVENT:

DESIGN CRITERIA:

Design Storm (year):	100	
IDF Regression Constants: (a)	1735.688	
(b)	6.014	
(c)	0.820	

EXISTING RELEASE RATE - SUMMARY:

Catchment ID	Area (A) ha	Runoff Coefficient (C)	Time of Concentration (tc) min	Intensity (I) mm/hr	Release Rate (Q) L/s	Release Flow Per Unit Area (Q/ha) L/s/ha
Subject Site	0.213	1.00	10	178.56	105.80	496.00



PROJECT NAME: Redevelopment of 384 Arlington Ave
CIMA+ PROJECT NUMBER: A001273
CLIENT: Windmill Development Group Ltd.
PROJECT STATUS: Site Servicing and Stormwater Management Report

STORM PRE-DEVELOPMENT FLOW - EXISTING SITE FLOWS

NOTES:

1. Calculated Time of Concentration (tc) using Bransby Williams ($C > 0.4$) is 3 min. Minimum Tc of 10 min used per City Standard.
2. Calculated runoff coefficient (C) equal to 0.88 for 2-year event and 1.00 for 100-year event.
3. IDF Parameters per City of Ottawa Sewer Design Guidelines, 2012 (Macdonald-Cartier International Airport)

Prepared by: Jaymeson Adams, P.Eng.
PEO# 100519478

Date: 2022/07/07

Verified by: Tim Kennedy, P.Eng.
PEO# 100173201

Date: 2022/07/21



PROJECT NAME: Redevelopment of 384 Arlington Ave
CIMA+ PROJECT NUMBER: A001272
CLIENT: Windmill Development Group Ltd.
PROJECT STATUS: Site Servicing and Stormwater Management Report

STORM RUNOFF COEFFICIENT DETERMINATION (POST-DEVELOPMENT)

APPLICABLE DESIGN GUIDELINES:

1. City of Ottawa Sewer Design Guidelines, 2012

POST-DEVELOPMENT RUNOFF COEFFICIENT DETERMINATION:

Area	Pervious Area m ²	Pervious Area Runoff Coefficient	Impervious Area m ²	Impervious Area Runoff Coefficient	Total Area m ²	Weighted Runoff Coefficient (2-year)	Weighted Runoff Coefficient (100-year)
Roof & Drains (A1)	14	0.20	1847	0.90	1861	0.89	1.00
Unattenuated Area (NC1)	45	0.20	228	0.90	272	0.79	0.98
TOTAL	59	0.20	2075	0.90	2133	0.88	1.00

NOTES:

For 25 year storms add 10% to C value
 For 50 year storms add 20% to C value
 For 100 year storms add 25% to C value

Prepared by: Martin Frechette, EIT

Date: 2024-09-30

Verified by: Eric Potvin, P.Eng.
PEO# 100208490

Date: 2024-09-30



PROJECT NAME: Redevelopment of 384 Arlington Ave
CIMA+ PROJECT NUMBER: A001272
CLIENT: Windmill Development Group Ltd.
PROJECT STATUS: Site Servicing and Stormwater Management Report

STORM PRE- VS POST DEVELOPMENT FLOW - UNATTENUATED AREA NC1 (100-YEAR)

APPLICABLE DESIGN GUIDELINES:

1. City of Ottawa Sewer Design Guidelines, 2012

PRE- vs POST-DEVELOPMENT FLOW DETERMINATION FOR UNATTENUATED AREAS:

DESIGN CRITERIA:

Design Storm (year):	100	
IDF Regression Constants: (a)	1735.688	
(b)	6.014	
(c)	0.820	
IDF Curve Equation (mm/hr):	$I = a / (\text{Time in min} + b)^c$	
Rational Formula (L/s):	$Q = 2.78C \cdot I \cdot A$	where: Q = Flow (L/s) C = Runoff Coefficient I = Rainfall Intensity (mm/hr) A = Area

RELEASE RATE SUMMARY - UNATTENUATED AREAS - PRE- vs POST-DEVELOPMENT (100-year):

	Area	Runoff Coefficient	Weighted Runoff Coefficient	Time of Concentration	Intensity	Release Rate	Release Flow Per Unit Area
	(A) ha	(C)	(C)	(tc) min	(I) mm/hr	(Q) L/s	(Q/ha) L/s/ha
Pre-development (NC1)	0.0263	0.90	1.00	10	178.56	13.0	496.00
Post-development (NC1)	0.0263	0.79	0.98	10	178.56	12.8	486.08
Variance (Post minus Pre)						-0.3	-9.92

NOTES:

1. Calculated Time of Concentration (tc) using Bransby Williams (C > 0.4) is 7 min. Minimum Tc of 10 min used per City Standard.
2. IDF Parameters per City of Ottawa Sewer Design Guidelines, 2012 (Macdonald-Cartier International Airport)
3. The proposed development will improve the condition of the unattenuated area by replacing existing impermeable surfaces with permeable ones.

Prepared by: Martin Frechette, EIT

Date: 2024-09-30

Verified by: Eric Potvin, P.Eng.
PEO# 100208490

Date: 2025-10-03



PROJECT NAME: 384 Arlington Avenue
 Residential Development
CIMA+ PROJECT NUMBER: A001272
CLIENT: Windmill Development Group Ltd.
PROJECT STATUS: Site Servicing and Stormwater Management Report

STORMWATER MANAGEMENT – RETENTION CALCULATIONS

APPLICABLE DESIGN GUIDELINES:

1. City of Ottawa Sewer Design Guidelines, 2012
2. City of Ottawa Technical Bulletin ISTB-2018

STORMWATER MANAGEMENT SUMMARY - STORAGE AND DRAWDOWN:

DESIGN CRITERIA:

Rainfall event	100 years
Flows from Tank	9.1 L/s
Unattenuated Flow (100 year)	0.0 L/s
Allowable Release Rate	9.1 L/s

Sub-Area	Total Area (m ²)	Available Storage Area (m ²)	Catchbasin/ Roof Drain Elevation (m)	Maximum Ponding Elevation (m)	Y _{max} (m)	V _{max} (m ³)	V _{rain} (m ³)	V _{acc} (m ³)	Y _{rain} (m)	Elev _{rain} (m)	A _{rain} (m ²)	Cistern Release Rate Q (L/s)	Drawdown Time (min)	Comments
A1	1869	0	-	-	-	75.00	72.2	72.2	-	-	-	9.1	-	Building Roof & Drains
NC1 (Unattenuated)	264	0	-	-	-	-	-	-	-	-	-	0.0	-	Unattenuated
Total	2133	0				75.0	72.2	72.2				9.1		

NOTES:

1. Given that the site was oversized per the City's request, using a runoff coefficient of 0.4 instead of the actual 0.90, and since the uncontrolled area conditions within its perimeter are being improved, the City modeler has approved the exclusion of this area from the 18 L/s allowable release rate for the site (see Appendix A for email confirmation). Furthermore, additional landscape areas are proposed outside the property limits, further enhancing the overall site conditions.

DEFINITIONS OF ABBREVIATIONS USED IN CALCULATION TABLE:

NC = Area is not controlled (unattenuated)	V _{acc} = Total volume of water accumulated within the sub-area in the event of a specific rainfall.
Available Area = Area of water accumulated in sub-area at Max. Elev.	Y _{rain} = Depth of water generated by rainfall.
Catchbasin Elev. = Elevation of catchbasin inlet (top of grate).	Elev _{rain} = Elevation of water generated by rainfall.
Max. Elev. = Maximum elevation of water that may be accumulated within sub-area.	A _{rain} = Area of water generated by rainfall.
Y _{max} = Maximum depth of water that may be accumulated within the sub-area.	Q = Release flow rate.
V _{max} = Maximum volume of water (capacity) that may be accumulated within the sub-area.	Tank Release Rate = Release rate from the underground storage tank equal to 1/2 the allowable release rate.
V _{rain} = Volume of water generated by rainfall.	Drawdown Time = Time required for the total volume of water accumulated within sub-area to subside.

Prepared by: Martin Frechette, EIT Date: 2024-10-30

Verified by: Eric Potin, P.Eng. Date: 2025-10-03
PEO# 100208490

G

Appendix G Blue-Green Roof Design





Green Roof Certification

384 Arlington Avenue
City of Ottawa, Ontario K1R 6Z5

Project No.: 24.213.ON
January 7, 2025

To whom it may concern,

The Project located at 384 Arlington Avenue in the City of Ottawa, ON (hereinafter referred to as the ‘Site’) covers an approximate area of **2133 sq. m** (uncontrolled 272 sq. m, controlled 1861 sq. m). Development will include a 24-storey residential building with three levels of underground parking. As of the June 2024 Assessment of Adequacy of Public Services Report drafted by CIMA+ (File No. A001272-370), the Site did not have any proposed stormwater volume management measures, aside from an underground storage tank (UST) to manage the post-development stormwater runoff flows. The UST was sized at **70.8 cu. m** with a release rate of **9.1 L/s** (50% of the allowable release rate) to account for fluctuating head and release rate. Subsequently, CIMA+ drafted a Site Servicing and Stormwater Management Report (SSSWMR, File No. A001272-370, 07 October 2024). The updated report still utilizes an underground storage tank to manage the post-development stormwater runoff flows, but it is now sized at **55 cu. m** with an allowable release rate of **18.2 L/s**. It also mentions that Blue-green roof design options will be considered.

The Landscape Architect Consultant (SpruceLab) proposes the Site Building will have Intensive Green Roof (IGR) Planters, Intensive Blue-Green Roof (IBGR) Planters, Intensive Blue-Green Roof (IBGR) Agriculture Beds and Blue Roofs (BR) to provide stormwater management for the Site. The areas for such practices were provided by Neuf Architects via Drawing No. A101 Site Plan and SpruceLab via Drawing No. L1.2 Landscape Plan 4th Floor and No. L1.3 Landscape Plan 7th Floor (Table 1).

Table 1: Site Surface Areas

Level	Surface Type	Area (sq. m)	Drain Count
Ground	Landscaping	179.75	0
	Planters	187.71	4
4	IGR Planters	9.24	0
	Pavers	223.70	4
7	IBGR Planters	7.05	0
	IBGR Agriculture Beds – Low	14.53	0
	IBGR Agriculture Beds – Raised	34.47	0
	Blue Roof Pavers	180.69	2
Mechanical	White Roof	447.44	8
Mech Roof	White Roof	219.82	2
All	Impervious	628.61 ¹	NA
Total =		2133.00	20
Intensive Green Roofs =		65.28	0
Blue Roofs =		236.73	2

¹ Calculated by subtracting the Total Site Area (provided by CIMA+ SSSWMR) by the measured surface types from the Neuf Architects Site Plan and SpruceLab Landscape Plans

ZinCo Canada Green/Blue Roof Systems

In recognition of the design standards for the vegetated roof systems, ZinCo Canada can provide the following certification regarding the retention and detention capacities of the Green, Blue-Green and Blue options. In accordance with the Planter detail (SpruceLab Drawing L2 Detail 3), ZinCo Canada proposes the following IGR Planter buildup: Perennial Plants, ZinCo Blend I Growing Media (depth **800 mm**), ZinCo Filter Sheet SF, ZinCo Drain and Water Storage Element Floradrain FD40, ZinCo Separation Membrane TGV21 and ZinCo Root Barrier WSF40 (Table 2, see ZinCo ‘Metal Planter’ detail). The retention capacity for the IGR Planter is **406 L/sq. m**.

Table 2: ZinCo Intensive Green Roof Metal Planter Buildup

	Layer	Depth (mm)	Storage Capacity (L/sq. m)
Green (Retention)	Plants: Perennials ²	NA	NA
	Growing Media: Blend I ³	800 ⁴	400
	Filter Sheet: SF	0.5	0
	Drainage: Floradrain FD40	40	6
Roof	Separation Membrane: TGV21	0.55	0
	Insulation	NA	0
	Root Barrier: WSF40	0.34	0
Total =		841	406
Runoff Coefficient (C) ⁵ =		0.1	

² Species selection is dependent on client desire and landscape planting plan

³ Retention Capacity: 5 L/sq. m/10 mm depth

⁴ Per SpruceLab Detail L2-3 Corten Steel Raised Planters (total available depth 830 mm)

⁵ ZinCo calculated C is based on Roof Slope and Storage Depth

To allow for a uniform drainage pathway for the Level 4 amenity area, ZinCo Canada proposes the following Walkway buildup: Pavers, High Performance Bedding (HPB, minimum depth 20 mm), ZinCo Drain and Water Storage Element Floradrain FD40 (drainage holes down for constant drainage), ZinCo Separation Membrane TGV21 and ZinCo Root Barrier WSF40 (Table 3, see ZinCo ‘Metal Planter’ detail).

Table 3: ZinCo Paver Walkway Buildup

	Layer	Depth (mm)	Storage Capacity (L/sq. m)
(Drainage)	Surface: Paver	NA	NA
	Support: HPB	20 ⁶	0
	Drainage: FD40 (drainage holes down)	40	0
Roof	Separation Membrane: TGV21	0.55	0
	Insulation	NA	0
	Root Barrier: WSF40	0.34	0
Total =		61	0
Runoff Coefficient (C) ⁵ =		0.5	

⁶ Minimum depth, confirm with Landscape/Architectural drawings.

Modeling the entire Level 7 as a detention area, ZinCo Canada proposes adding ZinCo Detention Spacers DSX100 under all the surface elements (Metal Planters, Agricultural Beds and Pavers) and Runoff Limiters RDS 28 to the two drains (see ZinCo Product Datasheets). On the **1.5-degree** sloped roof, the depth of water stored in the DSX100 maxes at **100 mm** (detention capacity of 95 L/sq. m) at the drains and goes to 0 mm 6.7 m from the drain – contributing to an average



detention capacity of **47.5 L/sq. m** across the entire roof area (**236.7 sq. m**). This results in a conservative detention volume of **11.2 cu. m**. The ZinCo Runoff Limiter RDS28 has variable position openings from completely closed (position 0) to fully open (position 32). At the maximum head (100 mm) and fully open position, the flow rate is **0.75 L/s**.

In accordance with the Planter detail (SpruceLab Drawing L2 Detail 3), ZinCo Canada proposes the following IBGR Planter buildup: Perennial Plants, ZinCo Blend I Growing Media (depth **800 mm**), ZinCo Filter Sheet SF, ZinCo Drain and Water Storage Element Floradrain FD40, Filter Sheet PV, Detention Spacer DSX100, ZinCo Separation Membrane TGV21 and ZinCo Root Barrier WSF40 (Table 4, see ZinCo ‘Metal Blue-Green Planter’ detail). The retention capacity for the IBGR Planter is **406 L/sq. m**.

Table 4: ZinCo Intensive Blue-Green Roof Metal Planter Buildup

	Layer	Depth (mm)	Storage Capacity (L/sq. m)
Green (Retention)	Plants: Perennials ²	NA	NA
	Growing Media: Blend I ³	800 ⁴	400
	Filter Sheet: SF	0.5	0
	Drainage: Floradrain FD40	40	6
Blue (Detention)	Filter Sheet: PV	1.4	0
	Detention: DSX100 with RDS28	100	47.5
Roof	Separation Membrane: TGV21	0.55	0
	Insulation	NA	0
	Root Barrier: WSF40	0.34	0
Total =		943	453.5
Runoff Coefficient (C) ⁵ =		0.1	

ZinCo Canada proposes the following IBGR Agriculture Bed buildup: Vegetables, ZinCo Blend I Growing Media (depth **200 and 775 mm**), ZinCo Filter Sheet SF, ZinCo Drain and Water Storage Element Floradrain FD40, Filter Sheet PV, Detention Spacer DSX100, ZinCo Separation Membrane TGV21 and ZinCo Root Barrier WSF40 (Tables 5 and 6, see ZinCo ‘Blue-Green Agriculture Bed – Concrete’ and ‘Blue-Green Agriculture Bed – Raised’ details). The retention capacity for the IBGR Low Curbed Agricultural Bed is **106 L/sq. m**. The retention capacity of the IBGR Raised Agricultural Beds is **394 L/sq. m**.

Table 5: ZinCo Intensive Blue-Green Roof Agriculture Bed Buildup – Low Curbed Beds

	Layer	Depth (mm)	Storage Capacity (L/sq. m)
Green (Retention)	Plants: Vegetables ²	NA	NA
	Growing Media: Blend I ³	200 ⁷	100
	Filter Sheet: SF	0.5	0
	Drainage: Floradrain FD40	40	6
Blue (Detention)	Filter Sheet: PV	1.4	0
	Detention: DSX100 with RDS28	100	47.5
Roof	Separation Membrane: TGV21	0.55	0
	Insulation	NA	0
	Root Barrier: WSF40	0.34	0
Total =		343	153.5
Runoff Coefficient (C) ⁵ =		0.2	

⁷ Per SpruceLab correspondence (25 July 2024 and 09 September 2024) of 6-8 inches



Table 6: ZinCo Intensive Blue-Green Roof Agriculture Bed Buildup – Raised Beds

	Layer	Depth (mm)	Storage Capacity (L/sq. m)
Green (Retention)	Plants: Vegetables ²	NA	NA
	Growing Media: Blend I ³	775 ⁸	387.5
	Filter Sheet: SF	0.5	0
	Drainage: Floradrain FD40	40	6
Blue (Detention)	Filter Sheet: PV	1.4	0
	Detention: DSX100 with RDS28	100	47.5
Roof	Separation Membrane: TGV21	0.55	0
	Insulation	NA	0
	Root Barrier: WSF40	0.34	0
Total =		918	441.0
Runoff Coefficient (C) ⁵ =		0.1	

⁸ Per SpruceLab correspondence of equivalent heights for the Raised Beds with the BUFCO Wood Frame Wheelchair Accessible Raised Garden Bed, Double-Sided, 3-Bay

To create a uniform detention buildup across the entire Level 7 roof area, ZinCo Canada proposes the following BR with Pavers buildup: Pavers, High Performance Bedding (HPB, minimum depth 20 mm above the drainage layer), ZinCo Detention Spacer DSX100, Filter Sheet PV, ZinCo Separation Membrane TGV21 and ZinCo Root Barrier WSF40 (Table 7, see ZinCo ‘Hardscaping – DSX100’ detail).

Table 7: ZinCo Blue Roof Paver Buildup

	Layer	Depth (mm)	Storage Capacity (L/sq. m)
Blue (Detention)	Surface: Paver	NA	NA
	Support: HPB	20 ⁶	0
	Filter Sheet: PV	1.4	0
	Detention: DSX100 with RDS28	100	47.5
Roof	Separation Membrane: TGV21	0.55	0
	Insulation	NA	0
	Root Barrier: WSF40	0.34	0
Total =		122	47.5
Runoff Coefficient (C) ⁵ =		0.4	

The retention and detention capacities of the systems noted in this report are based on continual testing and improvement to the ZinCo green roof system by the ZinCo GmbH Research & Development Lab, and therefore there are no concerns from ZinCo Canada with respect to the storage capacities of the proposed systems.

Stormwater Quantity (Peak Flow) Management

The CIMA+ Report states that the City of Ottawa requires the post-development **100-year** storm event peak runoff rate for the Site must be controlled to the **2-year** pre-development release rate. The **2-** and **100-year** storm events’ rainfall intensities (I) are calculated using the Intensity-Duration-Frequency Curve per the City of Ottawa Sewer Design Guidelines (2012) with a time of concentration (Tc) of **10 minutes** (Equations 1 & 2).

$$I \left(\frac{mm}{hr} \right) = A / (T_{c,min} + B)^c = 732.951 / (10 + 6.199)^{0.810} = 76.81 \tag{Equation 1}$$

$$I \left(\frac{mm}{hr} \right) = A / (T_{c,min} + B)^c = 1735.688 / (10 + 6.014)^{0.820} = 178.56 \tag{Equation 2}$$

Despite the pre-development conditions being dominantly impervious (Runoff Coefficient, C, **0.9**), the allowable release rate was determined using a C of **0.4** due to concerns about the capacity of the receiving combined sewer (Equation 3).

$$Q \left(\frac{L}{s} \right) = 2.78 \cdot C \cdot I \cdot A_{hectares} = 2.78 \cdot 0.4 \cdot 76.81 \cdot 0.213 = 18.2 \tag{Equation 3}$$

The post-development conditions include a non-controlled catchment area (NC1, Area: 0.027 ha, C: 0.79, 100-year C: 0.98) and the Site Building (A1, Area: 0.186 ha, C: 0.89, 100-year C: 1.00) with no stormwater management practices. The underground storage tank (UST) is sized to manage the runoff only from the Building catchment. The CIMA+ Report sized the UST to **55 cu. m** by using the allowable release rate (**18.2 L/s**).

Table 10 outlines the **100-year** post-development peak flow rates and UST volumes associated with the following stormwater management practice options: (1) using typical impervious (0.90) and pervious (0.20) runoff coefficient values and (2) using the ZinCo Canada certified runoff coefficient values. Taking into account the stormwater management practices with the typical C values, the required tank size decreases to **44 cu. m**. Utilizing the ZinCo C values, the required tank size decreases to **36 cu. m**. The Level 7 Blue Roof practices can store **11 cu. m** of that volume assuming runoff from upper levels are routed to Level 7.

Table 10: Post-Development Peak Flows and UST Volume Requirements

Catchment		Area (ha)	Runoff Coefficient (C)	
			Opt. 1	Opt. 2
A1	Level 4 IGR Planters	0.001	0.20	0.10
	Level 4 Pavers	0.022	0.90	0.50
	Level 7 IBGR Planter	0.001	0.20	0.10
	Level 7 IBGR Ag. Beds – Low	0.001	0.20	0.20
	Level 7 IBGR Ag. Beds – Raised	0.003	0.20	0.10
	Level 7 Blue Roof Pavers	0.018	0.90	0.40
	White Roof	0.067	0.90	0.90
	Impervious	0.072	0.90	0.90
Total		0.186	0.88	0.78
100-Year Peak Flow (L/s)		-	80.9	71.7
UST Volume (cu. m)		-	43.4	36.0
ZinCo Detention Storage (cu. m)		-	-	11.2



Green Roof Certification

384 Arlington Avenue
City of Ottawa, Ontario K1R 6Z5

Project No.: 24.213.ON

January 7, 2025

Conclusions

The above Green Roof Certification was drafted to showcase the stormwater management capabilities of various Green-, Blue-, and Blue-Green Roof designs to manage the Site Stormwater Quantity.

- **Existing Conditions:** No stormwater management practices considered in the Stormwater Quantity Control.
 - 100-Year Post-Development Peak Flow Rate (92.4 L/s) must be controlled to the 2-Year Pre-Development Allowable Release Rate (18.2 L/s); Required UST Volume: 55 cu. m.
- **Option 1:** Utilize the typical Runoff Coefficient (C) values for pervious and impervious surfaces.
 - 100-Year Peak Flow Rate: 80.9 L/s, Required UST Volume: 44 cu. m
- **Option 2:** Utilize the ZinCo Canada certified C values for the Level 4 Metal Planters, Level 4 Pavers, Level 7 Metal Blue-Green Planters, Level 7 Blue-Green Agricultural Beds, Level 7 Blue Roof.
 - 100-Year Peak Flow Rate: 71.7 L/s, Required UST Volume: 36 cu. m
 - Provided Detention Volume (Level 7): 11 cu. m

Any questions or concerns regarding this letter can be directed to the individual below.

Sincerely,

Giuliana Frizzi

Giuliana Frizzi, M.A.Sc., EIT, LEED GA, GRIMP
Technical Consultant and Project Coordinator
E: gfrizzi@zinco.ca
P: 905-929-4626



The **Green Roof** Experts

ZinCo Canada Inc. - P.O. Box 29 - Carlisle - Ontario - L0R 1H0
T. 1-905-690-1661 - E. greenroof@zinco.ca - W. www.zinco.ca

"Metal Planter" Intensive Green Roof with Floradrain® FD 40

Detail:
System Build-up with Walkway

System Build-up:

- 1.1 Metal Planter (open bottomed)
- 1.2 Perennials
- 1.3 Growing Media ZinCo Blend I, depth according to Landscape plans
- 1.4 Filter Sheet SF
- 1.5 Floradrain® FD 40 (drainage openings facing upwards for water retention)
- 1.6 Separation Membrane TGV 21
- 1.7 XPS Thermal insulation
- 1.8 Roof construction with root resistant waterproofing or Root Barrier WSF40/WSB100

- 2.1 Hardscaping Material
- 2.2 High Performance Bedding (HPB)
- 2.3 Floradrain® FD 40 filled with HPB (drainage openings facing down for drainage)

Note:

The detailed solution shown here refers mainly to the ZinCo System Build-up. The roof construction itself as well as any other constructions are shown schematically and must be planned according to the relevant standards and guidelines.

Project:

– 24.213.ON_384Arlington

Version:
2024.09.17

Reviewed:
– G.F.

Scale:
none

Size:
A 4

Authorized by ZinCo Canada Inc.
557 Carlisle Rd, Carlisle ON
L0R 1H0
P.O Box 29
1 (905) 690-1661
greenroof@zincocanada.ca



zinco.ca

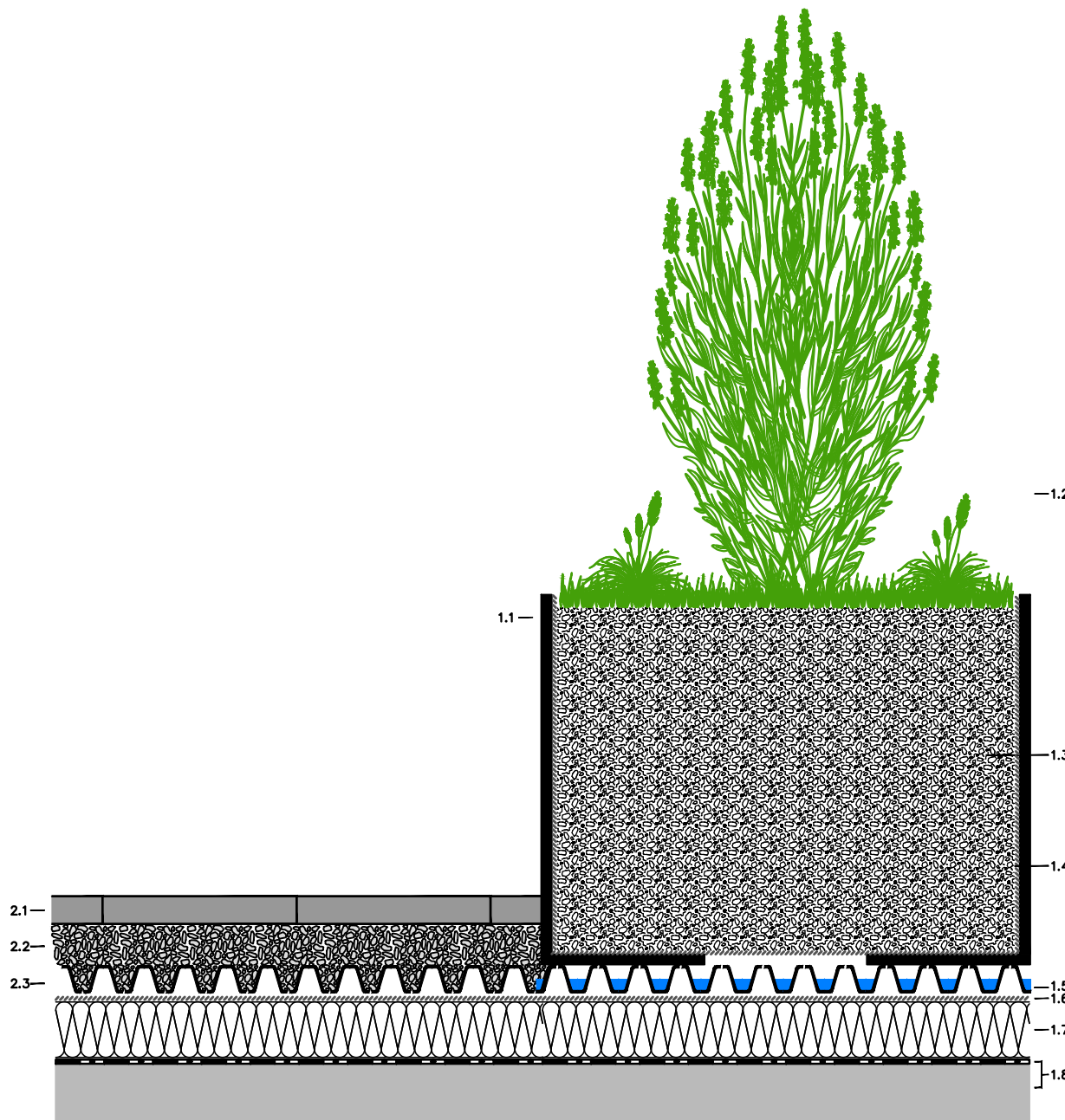

Product Data Sheet

Order No. 3402 / 3409
3403 / 3415

Detention Spacer DSX 65 / DSX 80 / DSX 100 / DSX 150

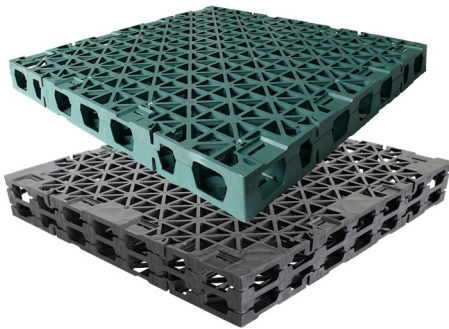

Powerful Spacer Elements made of polypropylene for their use on roof surfaces without any inclination, especially for detention build-ups meant for heavy load (e.g. in walkways and driveways).

Technical Data

Detentions Spacer DSX 65 / DSX 80 / DSX 100 / DSX 150
Heavy duty Spacer Element made of polypropylene, cavity volume > 95 %.

Material: 100 % Polypropylene
Dimensions: ca. 0.60 m x 0.60 m
Compressive strength according to EN ISO 17151: up to 50 t/m²

	Order No.	Height	Weight	Maximum detention volume:
DSX 65	3402	ca. 65 mm	ca. 6.2 kg/m ²	ca. 60 l/m ²
DSX 80	3409	ca. 80 mm	ca. 6.3 kg/m ²	ca. 76 l/m ²
DSX 100	3403	ca. 100 mm	ca. 6.5 kg/m ²	ca. 95 l/m ²
DSX 150	3415	ca. 150 mm	ca. 8.0 kg/m ²	ca. 142 l/m ²

Accessories:

Plastic Connector Order No. 9622
(requirement: 4 pieces per element \approx ca. 11 pcs./m²)



The Spacer Elements can be connected with each other using special interlocks.

Features

- provides for additional water detention on roofs without inclination
- developed specially for its use under high loads (e.g. walkways and driveways)
- high detention volume
- spacious channel system for aeration and drainage
- biologically and chemically neutral
- on request also deliverable in greater heights

Application Example

"Driveway with Detention Spacer DSX 65"

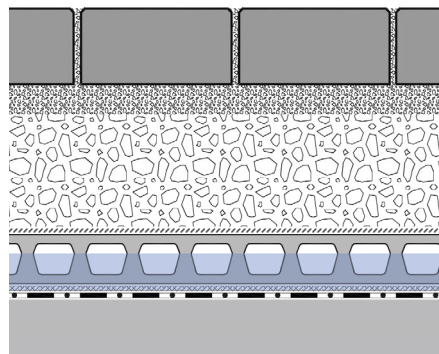

Paving slabs in a bedding of stone chippings

Gravel base layer

Filter Sheet PV

Detention Spacer DSX 65

Filter Sheet PV

Roof construction with waterproofing / waterproof concrete

Specification Suggestion

Spacer Elements made of polypropylene, height ca. 65 / 80 / 100 / 150 mm, with an integrated multidirectional channel system, cavity volume > 95 %, max. detention volume ca. 60 / 76 / 95 / 142 l/m², compressive strength up to 50 t/m²,

delivery and installation according to manufacturer's instructions.
Make: ZinCo Detention Spacer DSX 65 / DSX 80 / DSX 100 / DSX 150
Enquiries: ZinCo Canada Inc.
Phone: 905-690-1661

Product Data Sheet

Retention Run-off Limiter Set RDS 28

Order No. 4000



Adjustable flow-control device for roof outlets with contact flange, held in place by own weight.



Flow-control device from below

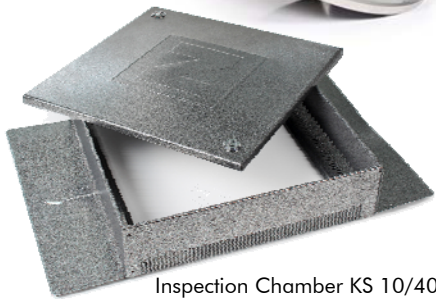

Inspection Chamber KS 10/40

Technical Data

Retention Run-off Limiter Set RDS 28

Adjustable flow-control device to be installed on flat roofs over water outlets with a contact flange; including a suitable inspection chamber; suitable for installation on Stormwater Management Roofs (Blue Roofs) with rainwater attenuation up to ca. 85 mm. The discharge rate is adjustable via a scale.

Retention Run-off Limiter RD 28

Material	rigid PVC
Diameter flow-control device:	ca. 280 mm
(inner) diameter overflow pipe:	ca. 75 mm
Adjustable height overflow:	ca. 20 mm - 85 mm
Adjustable flow rate with	
initial attenuation height of 55 mm:	from ca. 0.025 l/s up to ca. 0.60 l/s
initial attenuation height of 85 mm:	from ca. 0.030 l/s up to ca. 0.75 l/s

Inspection Chamber KS 10/40 (Order No. 4011)

Made of plastic-coated aluminium with lateral slots for water passage. Detachable and lockable cover made of galvanized, plastic-coated steel. Colour: old silver-antique.

Height:	ca. 100 mm
Outer dimensions (at transportation):	ca. 400 x 400 mm
Flange (extended, including chamber):	ca. 400 x 630 mm
Aperture dimensions:	ca. 340 x 340 mm

Weight of the complete Set: ca. 7 kg

Accessory: Extension Piece for KS 10/40, Height ca. 100 mm (Order No. 4012)

Features

- for installation of Stormwater Management Roofs on 0°-roofs in combination with spacer elements for rainwater attenuation
- flow-control device fits for rainwater outlets with contact flange (bitumen, plastic or elastomeric membranes)
- discharge rate adjustable to roof size and requested attenuation height
- overflow adjustable from 20 mm to 85 mm

Application Example

Stormwater Management Roof with extensive Green Roof „Sedum Carpet“

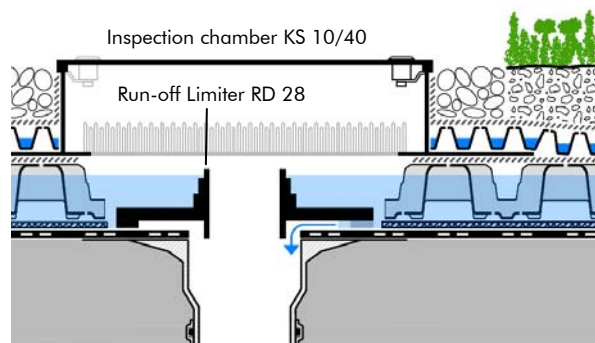

Vegetation „Sedum Carpet“
System substrate „Sedum Carpet“, ca. 60 mm
Filter Sheet SF
Floradrain® FD 25-E
Filter Sheet PV
Retention Spacer RS 60
System Filter PV
0°- roof with root resistant waterproofing

Specification Suggestion

Flow-control device with adjustable flow rate and overflow height, material: rigid PVC, delivery and installation above rainwater outlets to manufacturer's instructions, including product specific inspection chamber. Flow rate adjustment ac-

ording to drainage planning, attenuation height to be adjusted onsite.
Make: ZinCo Retention Run-off Limiter Set RDS 28
Enquiries: ZinCo GmbH,
Phone: +49 7022 6003-0

"Blue-Green Roof Metal Planter" with Floradrain® FD 40 and Detention Spacer DSX100

Detail:
System Build-up with Walkway

System Build-up:

- 1.1 Metal Planter (open bottomed)
 - 1.2 Perennials
 - 1.3 Growing Media ZinCo Blend I, depth according to Landscape plans
 - 1.4 Filter Sheet SF
 - 1.5 Floradrain® FD 40 (drainage openings facing upwards for water retention)
 - 1.6 Filter Sheet PV
 - 1.7 Detention Spacer DSX 100
 - 1.8 Separation Membrane TGV 21
 - 1.9 XPS Thermal insulation
 - 1.10 Roof construction with root resistant waterproofing or Root Barrier WSF40/WSB100
-
- 2.1 Hardscaping Material
 - 2.2 High Performance Bedding (HPB)

Note:

The detailed solution shown here refers mainly to the ZinCo System Build-up. The roof construction itself as well as any other constructions are shown schematically and must be planned according to the relevant standards and guidelines.

Project:

– 24.213.ON_384Arlington

Version:

2024.09.17

Reviewed:

– G.F.

Scale:

none

Size:

A 4

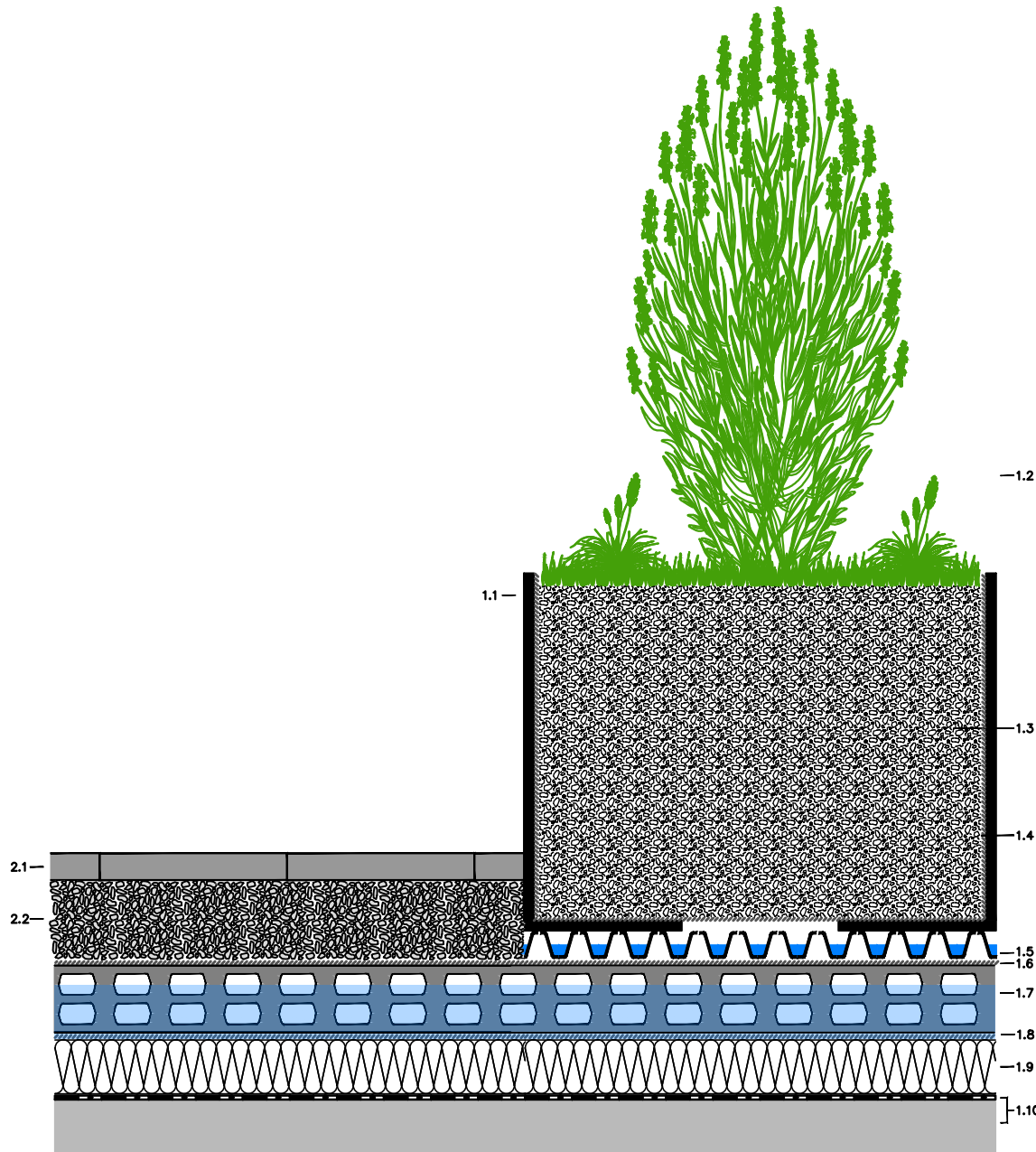

Authorized by ZinCo Canada Inc.
557 Carlisle Rd, Carlisle ON
L0R 1H0
P.O Box 29
1 (905) 690-1661
greenroof@zincocanada.ca



zinco.ca

"Blue-Green Roof Agriculture Bed" with Concrete Curbing and Floradrain® FD 40 and Detention Spacer DSX 100

Detail:
System Build-up with Walkway

System Build-up:

- 1.1 Concrete Curb in concrete foundation poured in FD 40
- 1.2 Vegetables
- 1.3 Growing Media ZinCo Blend I, depth according to Landscape plans
- 1.4 Filter Sheet SF
- 1.5 Floradrain® FD 40 (drainage openings facing upwards for water retention)
- 1.6 Filter Sheet PV
- 1.7 Detention Spacer DSX 100
- 1.8 Separation Membrane TGV 21
- 1.9 XPS Thermal insulation
- 1.10 Roof construction with root resistant waterproofing or Root Barrier WSF40/WSB100
- 2.1 Hardscaping Material
- 2.2 High Performance Bedding (HPB)

Note:

The detailed solution shown here refers mainly to the ZinCo System Build-up. The roof construction itself as well as any other constructions are shown schematically and must be planned according to the relevant standards and guidelines.

Project:
– 24.213.ON_384Arlington

Version:	Reviewed:	Scale:	Size:
2024.09.17	– G.F.	none	A 4

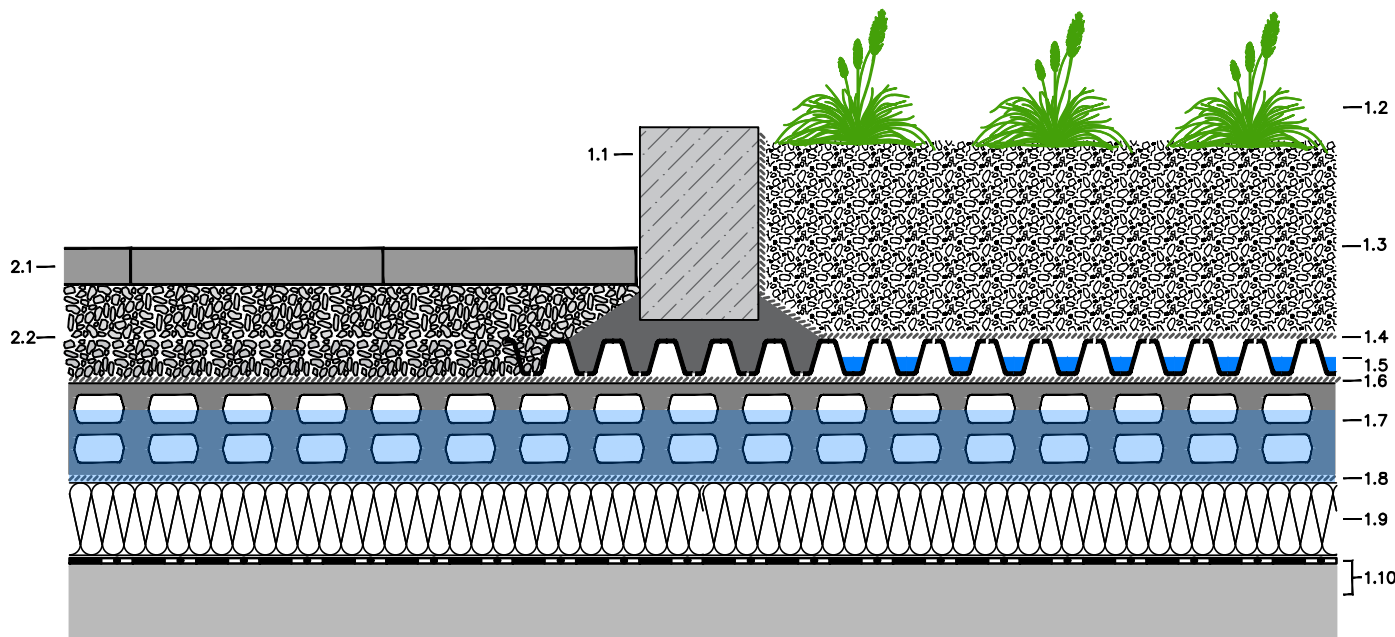

Authorized by ZinCo Canada Inc.
557 Carlisle Rd, Carlisle ON
L0R 1H0
P.O Box 29
1 (905) 690-1661
greenroof@zincocanada.ca



zinco.ca

"Blue-Green Roof Agriculture Bed" Raised Bed with Floradrain® FD 40 and Detention Spacer DSX 100

Detail:
System Build-up with Walkway

System Build-up:

- 1.1 Raised Bed, material according to Landscape Plans (open bottomed)
- 1.2 Vegetables
- 1.3 Growing Media ZinCo Blend I, depth according to Landscape plans
- 1.4 Filter Sheet SF
- 1.5 Floradrain® FD 40 (drainage openings facing upwards for water retention)
- 1.6 Filter Sheet PV
- 1.7 Detention Spacer DSX 100
- 1.8 Separation Membrane TGV 21
- 1.9 XPS Thermal insulation
- 1.10 Roof construction with root resistant waterproofing or Root Barrier WSF40/WSB100
- 2.1 Hardscaping Material
- 2.2 High Performance Bedding (HPB)
- 2.3 Bench, refer to Landscape Plans

Note:

The detailed solution shown here refers mainly to the ZinCo System Build-up. The roof construction itself as well as any other constructions are shown schematically and must be planned according to the relevant standards and guidelines.

Project:

– 24.213.ON_384Arlington

Version:

2024.09.17

Reviewed:

– G.F.

Scale:

none

Size:

A 4

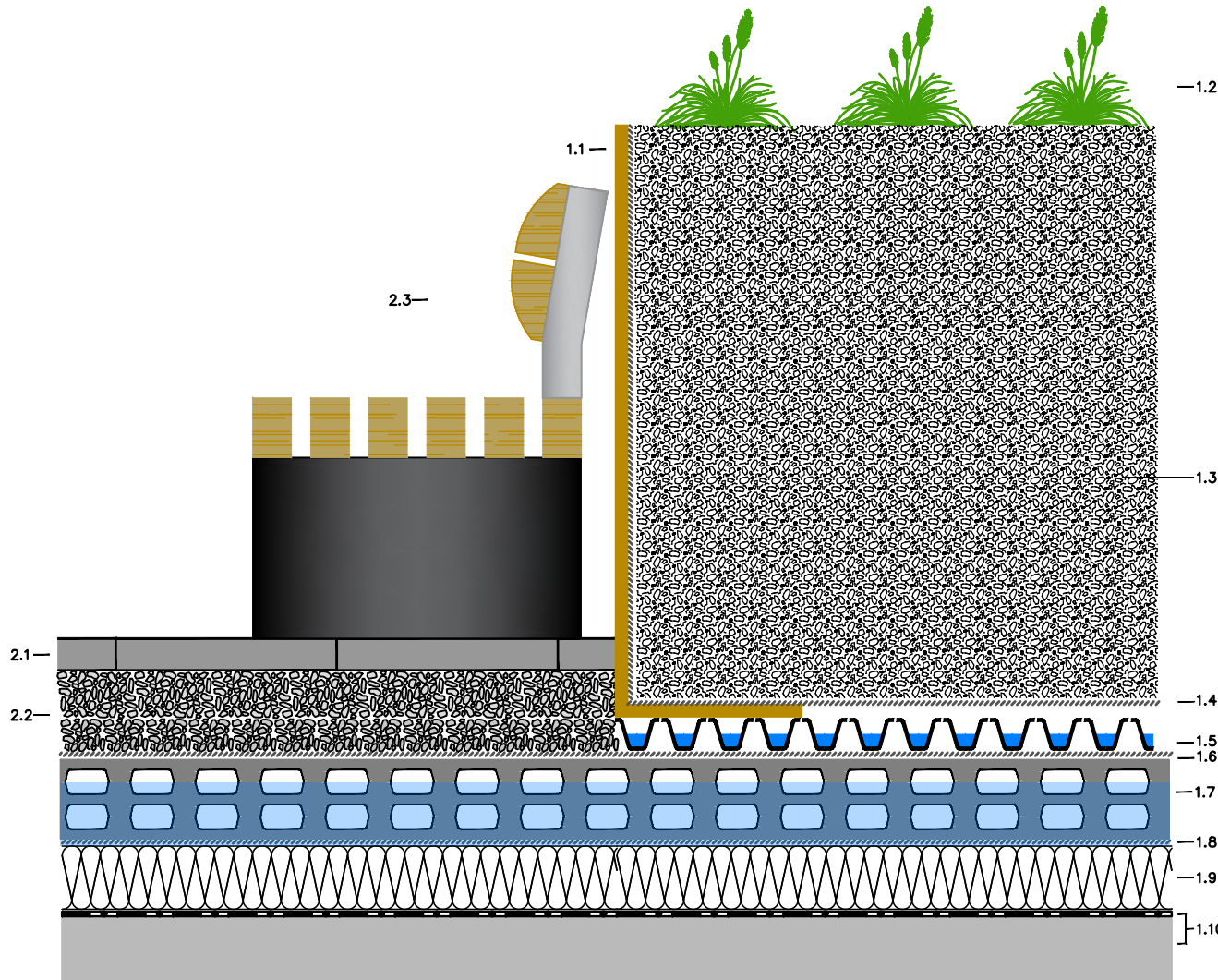

Authorized by ZinCo Canada Inc.
557 Carlisle Rd, Carlisle ON
L0R 1H0
P.O Box 29
1 (905) 690-1661
greenroof@zincocanada.ca



zinco.ca

"Hardscaping" Blue Roof with Detention Spacer DSX100 and Runoff Limiter RDS28

Detail:
System Build-up

System Build-up:

- 1.1 Hardscaping Material
- 1.2 High Performance Bedding (HPB)
- 1.3 Detention Spacer Element DSX100
- 1.4 Separation Membrane TGV 21
- 1.5 XPS Thermal insulation
- 1.6 Roof construction with root resistant waterproofing or Root Barrier WSF40/WSB100

- 2.1 Inspection Chamber KS 10/30
- 2.2 Retention Runoff Limiter Set RDS 28
- 2.3 Roof Drain

Note:

The detailed solution shown here refers mainly to the ZinCo System Build-up. The roof construction itself as well as any other constructions are shown schematically and must be planned according to the relevant standards and guidelines.

Project:
– 24.213.ON_384Arlington

Version:	Reviewed:	Scale:	Size:
2024.09.17	– G.F.	none	A 4

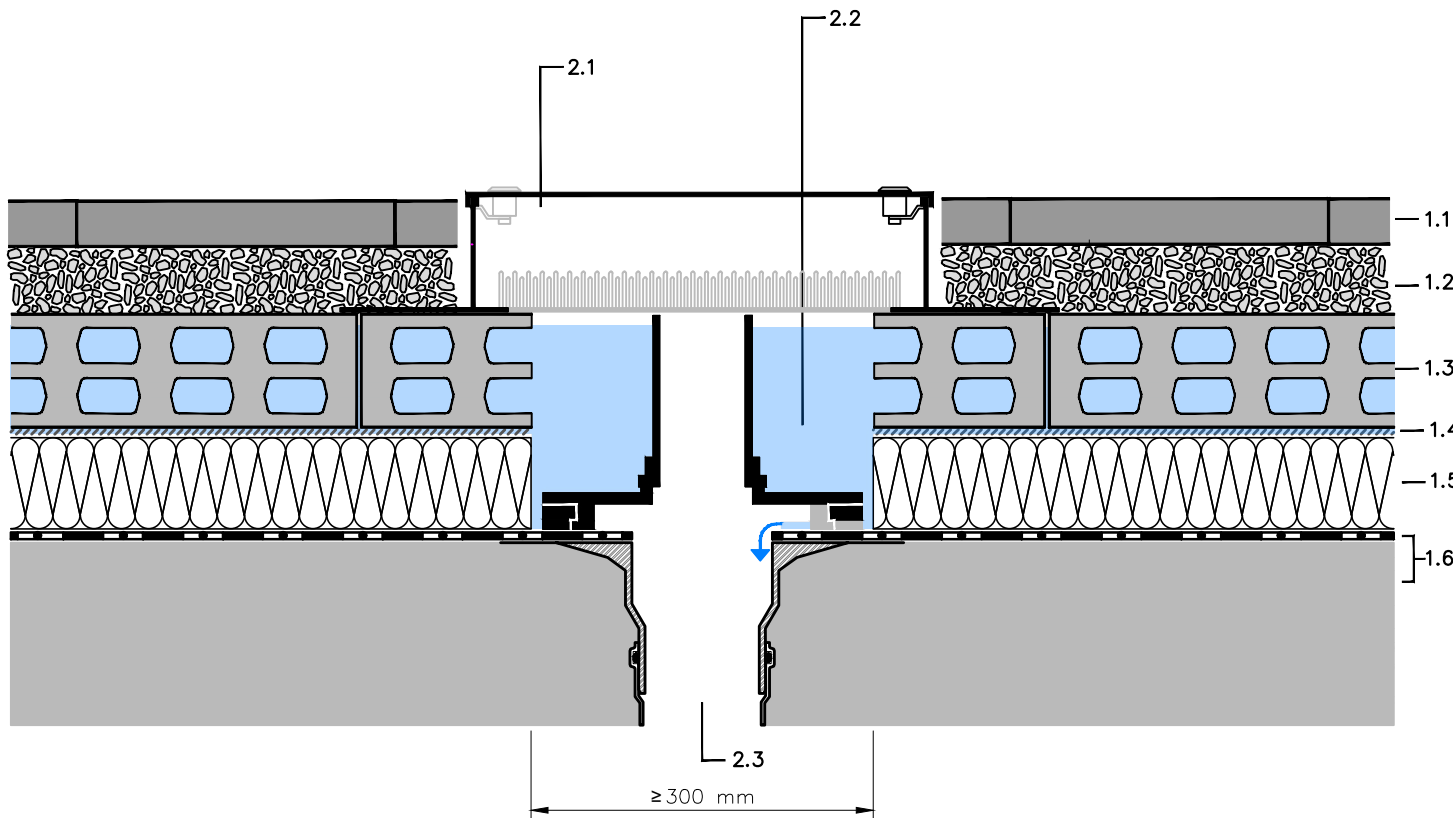

Authorized by ZinCo Canada Inc.
557 Carlisle Rd, Carlisle ON
LOR 1H0
P.O Box 29
1 (905) 690-1661
greenroof@zincocanada.ca



zinco.ca