

BÂTIMO DÉVELOPPEMENT INC.

PROJET: LIB ORLÉANS 500 FAMILLE-CÔTÉ AVENUE
OTTAWA

DOSSIER NO: 601401
DATE D'ÉMISSION: 2026-02-05

SHEET LIST TABLE

SHEET NUMBER	ÉMIS	TITRE
C-201		TECHNICAL AND GENERAL SPECIFICATIONS' LEGEND AND NOTES LOCATION
C-202		PLAN VIEW EXISTING ITEMS AND DEMOLITION
C-203		PLAN VIEW SITE GRADING AND DRAINAGE PLAN
C-204		PLAN VIEW SITE SERVICING PLANS AND DRAINAGE AREA
C-205		STANDARD SECTIONS AND DETAILS
C-206		FIRE HYDRANT COVERAGE MAP

HISTORIQUE DES ÉMISSIONS

DATE	DESCRIPTION
2025-09-15	FOR UDRP
2025-12-11	FOR SITE PLAN APPLICATION
2026-02-05	FOR SITE PLAN APPLICATION REV.01



135, boulevard de Sainte-Adèle, Sainte-Adèle (Qc) J8B 0J4
T 450 227 1857
info@equipelaurence.ca | equipelaurence.ca

TECHNICAL AND GENERAL SPECIFICATIONS

1.0 GENERAL SPECIFICATIONS

All work shall conform with Ontario building code, latest edition as well as local regulation and bylaws.

Contractor to verify all dimensions and report any discrepancies to the engineer immediately to get design confirmation before proceeding with construction.

Refer to the City of Ottawa for regulations and standards (supersedes provincial standards).

Refer to Ontario Provincial Standards for Roads and Public Works - Volume 3 for details.

Ontario provincial standards for roads and public works must also be respected.

Work to be performed in accordance with the Occupational Health and Safety Act and Regulations for Construction Projects.

All materials shall meet all current applicable standards set by the American Water Works Association ("AWWA"), Canadian Standards Association ("CSA"), the American National Standards Institute ("ANSI") safety criteria standards, American Society for Testing and Materials (ASTM), NSF/14, NSF/60 and NSF/61.

The Contractor will get approval for all materials selection from the Civil Engineer prior to delivery to the site.

BUILDING OWNER: BÂTIMO DÉVELOPPEMENT INC.

CONSULTING CIVIL ENGINEER: ÉQUIPE LAURENCE INC.

2.0 GENERAL INFORMATIONS

2.1 UNDERGROUND SERVICES

The plans show certain underground installations for the sole purpose to highlight the existence of cables, pipelines and underground structures. In the sectors where work must be performed, the contractor is responsible to verify himself with the competent authorities the existence and actual location of all cables, pipelines and existing underground structures that may affect the works.

Before beginning excavations, the contractor must thus contact the Ontario One Call (www.on1call.com), the municipal authorities and all other stake holders in order to identify on the field all existing underground structures whether they are shown on the plans or not.

He is responsible for damages to cables, pipelines and underground structures. No cost variation resulting from underground structures not shown or poorly located on the plans can be claimed against the building owner. Following the review of the plans and specifications, the contractor must notify the engineer of any error, omission or discrepancy noted by him before starting work.

2.2 EXISTING WATERMAIN AND SEWER CONDUITS

The location of the watermain and sewer pipes is approximate. The contractor must verify and validate the position and depth of the pipes by the means of meticulous excavations. Should discrepancies be observed, they must be provided to the engineer without delay in order that the required modifications are made to the construction plans. The contractor will have to coordinate with the city, the connecting works to the existing networks (watermain and sewers). No service interruption shall take place without the building owner's authorization or the relevant authorities.

2.3 PROTECTION AGAINST EROSION

As per "Erosion and sediment control guideline for urban construction" In all areas of the building site where there is a risk of erosion, the ground must be stabilized. Runoff water must be intercepted and routed to stabilized areas and this, throughout the construction period. The contractor must use the recognized methods to prevent the transport of sediments.

- Sediment barrier
- Mud mat
- Sedimentation pond
- Filtering berm and sediment trap
- Straw bale filter

Any intervention on the building site which may cause the transfer of sediments must be simultaneously accompanied by sediment capture measures.

2.4 DRAINING OF THE EXCAVATIONS

The contractor shall take all necessary precautions to prevent the penetration of surface waters and to evacuate surface, underground or sewer waters. Waste waters must be directed towards a combined sewer or a sanitary sewer and the surface and underground waters towards a storm sewer, a combined sewer or a ditch. In all cases, the diversion site must be submitted for approval.

The contractor must assume all required pumping and cleaning costs.

2.5 PAVEMENT PROTECTION

At all times, the movement of machinery and metal tracked vehicles is prohibited on paved surfaces unless plywood sheets with a 20mm normal thickness or rubber with a 12.5mm thickness are used in order to avoid damaging pavement. All repairs or complete replacements of pavement is the contractor's responsibility, who will have to pay all the costs.

2.6 CLEANING OF SITE

At the end of the construction works and as often as requested by the project superintendent, the contractor must clean and eliminate all construction generated debris and restore all construction affected areas. The cleaning of the construction site is included in the global market unit prices.

3.0 SITE GRADING

Surface topsoil layer stripping required.

Low-lying areas may be filled by utilising soil cut from higher areas and by importing suitable fill materials.

The approved subgrade may be raised to design subgrade level with approved compactable on-site soil, providing it is placed in maximum 300 mm thick lifts and each lift is compacted to at least 95% of the material's SPMD. As an alternative to subexcavation, a woven geotextile separator, such as Terratrack 24-15, Amoco 2002, Mirafi 500XL or equivalent, may be placed over spongy areas prior to placing the Granular 'B' sub-base layer.

4.0 CONCRETE WORKS

All weather exposed concrete shall have 5 to 8% air entrainment or as otherwise specified in Tables 2 and 4 of CSA A23.1.

Concrete sidewalk as per OPSD 310.010. Foundation consist of 150 mm minimum of granular 'A' material. Sidewalk concrete thickness shall be 200 mm.

Concrete barrier curb as per OPSD 600.110. Foundation consist of 150 mm minimum of granular 'A' material.



PROJECT LOCATION
NO SCALE

CIVIL ENGINEERING LEGEND

	EXISTING BUILDING
	PROPOSED BUILDING
	BOTTOM OF EMBANKMENT
	TOP OF EMBANKMENT
	DITCH CENTER
	DITCH TO BE REMOVED
	DITCH CENTER WITH ROCK FILL PROTECTION
	EXISTING FENCE
	FENCE TO BE REMOVED
	PROPOSED FENCE
	SILT FENCE BARRIER
	ISOLATED WETLAND
	EXISTING TREE
	WOODED AREA
	WOODED AREA TO BE REMOVED
	OVERLAND FLOW ROUTE
	GUARDRAIL
	STONE RETAINING WALL
	EXISTING FIRE HYDRANT
	PROPOSED FIRE HYDRANT
	EXISTING WATER SERVICE VALVE
	PROPOSED WATER SERVICE VALVE
	EXISTING WATER PIPE
	EXISTING WATER PIPE TO BE REMOVED
	PROPOSED WATER PIPE
	EXISTING DRINKING WATER SERVICE CONNECTION
	PROPOSED DRINKING WATER SERVICE CONNECTION
	EXISTING SANITARY SEWER AND MANHOLE
	PROPOSED SANITARY SEWER AND MANHOLE
	SANITARY SEWER AND MANHOLE TO BE REMOVED
	EXISTING STORM SEWER PIPE AND MANHOLE
	PROPOSED STORM SEWER PIPE AND MANHOLE
	STORM SEWER AND MANHOLE TO BE REMOVED
	CULVERT
	EXISTING CATCH BASIN OR MANHOLE-CATCH BASIN
	PROPOSED CATCH BASIN OR MANHOLE-CATCH BASIN
	EXISTING STORM SEWER MANHOLE
	PROPOSED STORM SEWER MANHOLE
	EXISTING SANITARY SEWER MANHOLE
	PROPOSED SANITARY SEWER MANHOLE
	LIGHTNING UNIT
	OVERHEAD WIRING AND GUY WIRE
	EXISTING GAS PIPELINE
	BELL CANADA UNDERGROUND CABLE
	UNDERGROUND ELECTRICAL WIRE
	PROPOSED ASPHALT SURFACE
	PROPOSED CONCRETE SIDEWALK/SLAB
	PAVER SIDEWALK
	PROPOSED GRASS SURFACE
	GRANULAR SURFACE
	PROPOSED TEMPORARY MUD MAT
	PROPOSED STONES SURFACE
	PROPOSED GRANITE STONES
	EXISTING ASPHALT SURFACE TO BE REMOVED
	EXISTING SURFACE TO BE REMOVED
	PROPOSED ELEVATION
	PROPOSED ELEVATION OF CONCRETE CURB
	PROPOSED ELEVATION OF CONCRETE SLAB
	PROPOSED TOP ELEVATION OF SIDEWALK
	PROPOSED TOP ELEVATION OF RETAINING WALL
	PROPOSED BOTTOM ELEVATION OF RETAINING WALL
	EXISTING ELEVATION OF SURFACE
	GRADING SLOPES
	NORTH

26.300 X
CB: 26.450 X
C: 26.450 X
G: 26.650 X
S: 26.450 X
TW: 26.450 X
BW: 26.450 X
-25.30
-3.00%

**THIS DOCUMENT MUST
NOT BE USED FOR
CONSTRUCTION**

REV	DESCRIPTION	PAR	DATE
C	FOR SITE PLAN APPLICATION REV.01	B.B.	2026-02-05
B	FOR SITE PLAN APPLICATION	B.B.	2025-12-11
A	FOR UDRP	B.B.	2025-09-15

CLIENT
BÂTIMO DÉVELOPPEMENT INC.
SUITE 400-6485, RUE DORIS-LUSSIER
BOISBRIAND, QUÉBEC
J7H 0E8

PROJET
LIB ORLÉANS
500 FAMILLE-CÔTÉ AVENUE
OTTAWA



135, boulevard de Sainte-Adèle, Sainte-Adèle (Qc) J8B 0J4
T. 450 227 1857
info@equipe-laurence.ca | equipe-laurence.ca

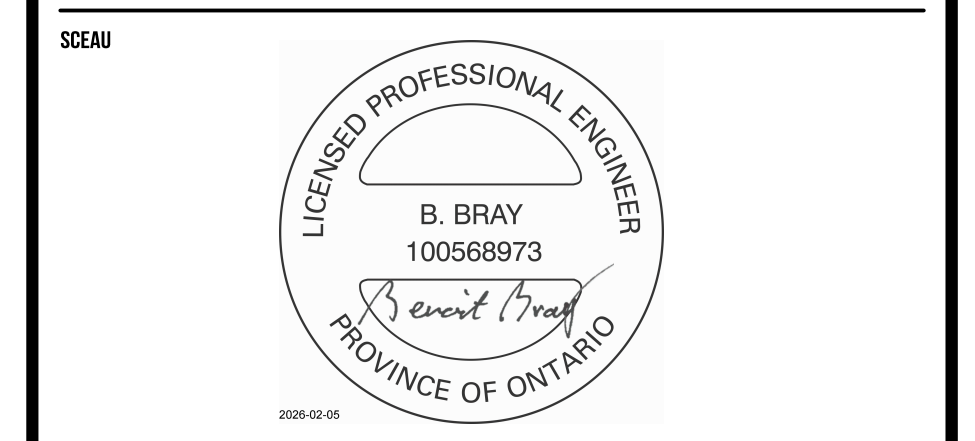

TITRE DU PLAN
TECHNICAL AND GENERAL SPECIFICATIONS'
LEGEND AND NOTES
LOCATION

ÉCHELLE
AUCUNE ÉCHELLE

ÉQUIPE DE PROJET
L.-C. TELLIER, techn.
J. FURTADO, ing.
V. MERCIER, ing.

DOSSIER NO
601401

PRÉPARÉ PAR
B. BRAY, ing.

FICHER
C-201.dwg

C-201

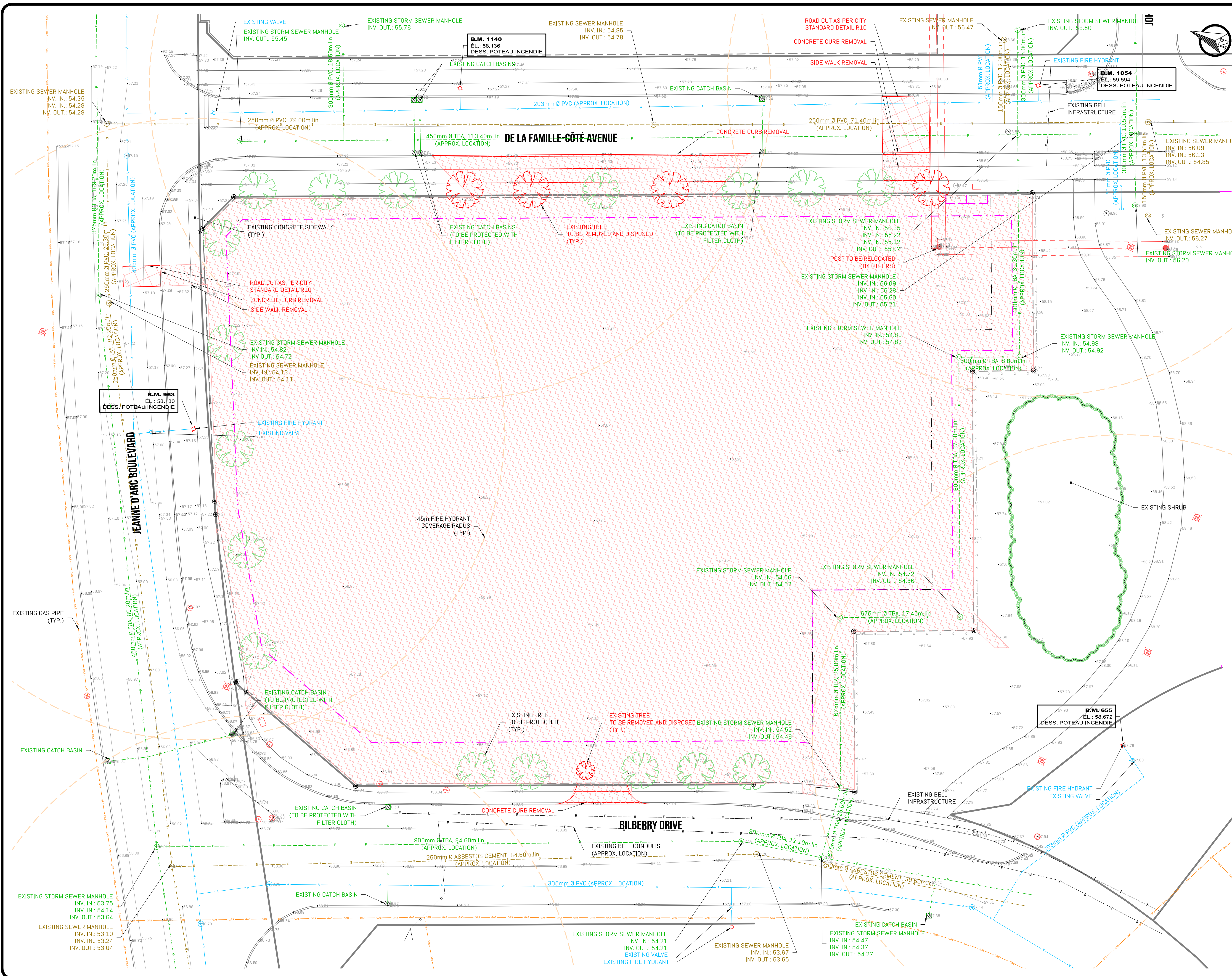

NOTE:
 THE EXISTING AND PROPOSED SUBDIVISION WILL HAVE TO BE VALIDATED BY THE SURVEYOR-GEOMETER ON FILE.

SURVEY AND LOTS INFORMATION PROVIDED BY ANNIS, O'SULLIVAN, VOLLEBECK LTD.
 DATE: AUGUST 19 2024
 FILE NO.: V-110937
 PLANIMETRIC REFERENCE SYSTEM: MTM NAD 83 ZONE 9
 ALTIMETRIC REFERENCE SYSTEM: CGVD28 HT2.0

THE CONTRACTOR MUST NOTIFY ÉQUIPE LAURENCE, THE CONSULTANT, IF HE NOTICES ANY DISCREPANCIES BETWEEN THE INFORMATION PRESENTED ON THE PLANS AND THE MEASUREMENTS TAKEN ON SITE SO THAT ADJUSTMENTS CAN BE MADE.
 WHEN APPLICABLE, HE MUST ALSO VERIFY THE ELEVATIONS OF EXISTING SEWERS BEFORE STARTING CONSTRUCTION AND MUST PROVIDE THE INFORMATION TO THE CONSULTANT.

THIS DOCUMENT MUST NOT BE USED FOR CONSTRUCTION

REV	DESCRIPTION	PAR	DATE
C	FOR SITE PLAN APPLICATION REV.01	B.B.	2026-02-05
B	FOR SITE PLAN APPLICATION	B.B.	2025-12-11
A	FOR UDRP	B.B.	2025-09-15

CLIENT
 BÂTIMO DÉVELOPPEMENT INC.
 SUITE 400-6485, RUE DORIS-LUSSIER
 BOISBRIAND, QUÉBEC
 J7H 0E9

PROJET
 LIB ORLÉANS
 500 FAMILLE-CÔTÉ AVENUE
 OTTAWA

135, boulevard de Sainte-Adèle, Sainte-Adèle (Qc) J8B 0J4
 T. 450 227 1857
 info@equipe-laurence.ca | equipe-laurence.ca

SCEAU

TITRE DU PLAN
 PLAN VIEW
 EXISTING ITEMS AND DEMOLITION

ECHELLE
 Horizontale 1:250

ÉQUIPE DE PROJET
 L.-C. TELLIER, techn.
 J. FURTADO, ing.
 V. MERCIER, ing.

DOSSIER NO
 601401

FICHER
 C-202.dwg

PRÉPARÉ PAR
 B. BRAY, ing.

C-202

SITE PLAN PREPARED BY
NEUF ARCHITECT(E)S
DATE: DECEMBER 01 2025

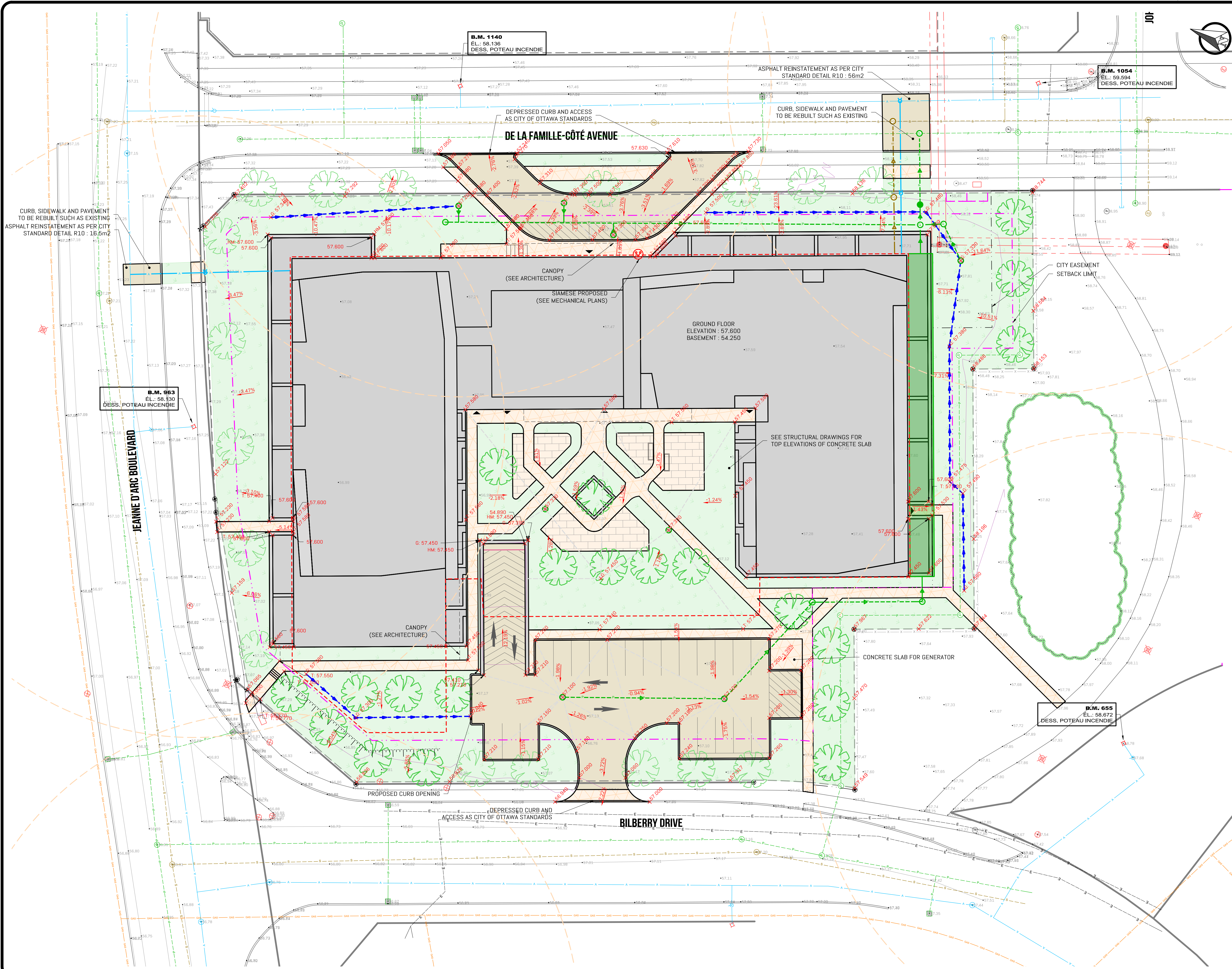

**THIS DOCUMENT MUST
NOT BE USED FOR
CONSTRUCTION**

REV	DESCRIPTION	PAR	DATE
C	FOR SITE PLAN APPLICATION REV.01	B.B.	2026-02-05
B	FOR SITE PLAN APPLICATION	B.B.	2025-12-11
A	FOR UDRP	B.B.	2025-09-15

CLIENT
BÂTIMO DÉVELOPPEMENT INC.
SUITE 400-6485, RUE DORIS-LUSSIER
BOISBRIAND, QUÉBEC
J7H 0E8

PROJET
LIB ORLÉANS
500 FAMILLE-CÔTÉ AVENUE
OTTAWA



135, boulevard de Sainte-Adèle, Sainte-Adèle (Qc) J8B 0L4
T. 450 227 1857
info@equipe-laurence.ca | equipe-laurence.ca

SCÉAU



LICENSED PROFESSIONAL ENGINEER
B. BRAY
100568973
Brevet (Ingr)
PROVINCE OF ONTARIO
2026-02-05

TITRE DU PLAN
**PLAN VIEW
SITE GRADING AND DRAINAGE PLAN**

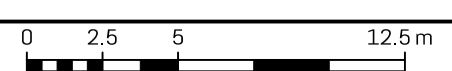
ECHELLE
Horizontale 1:250 

ÉQUIPE DE PROJET
L.-C. TELLIER, techn.
J. FURTADO, ing.
V. MERCIER, ing.

DOSSIER NO
601401

FICHER
C-203.dwg

PRÉPARÉ PAR
B. BRAY, ing.

C-203

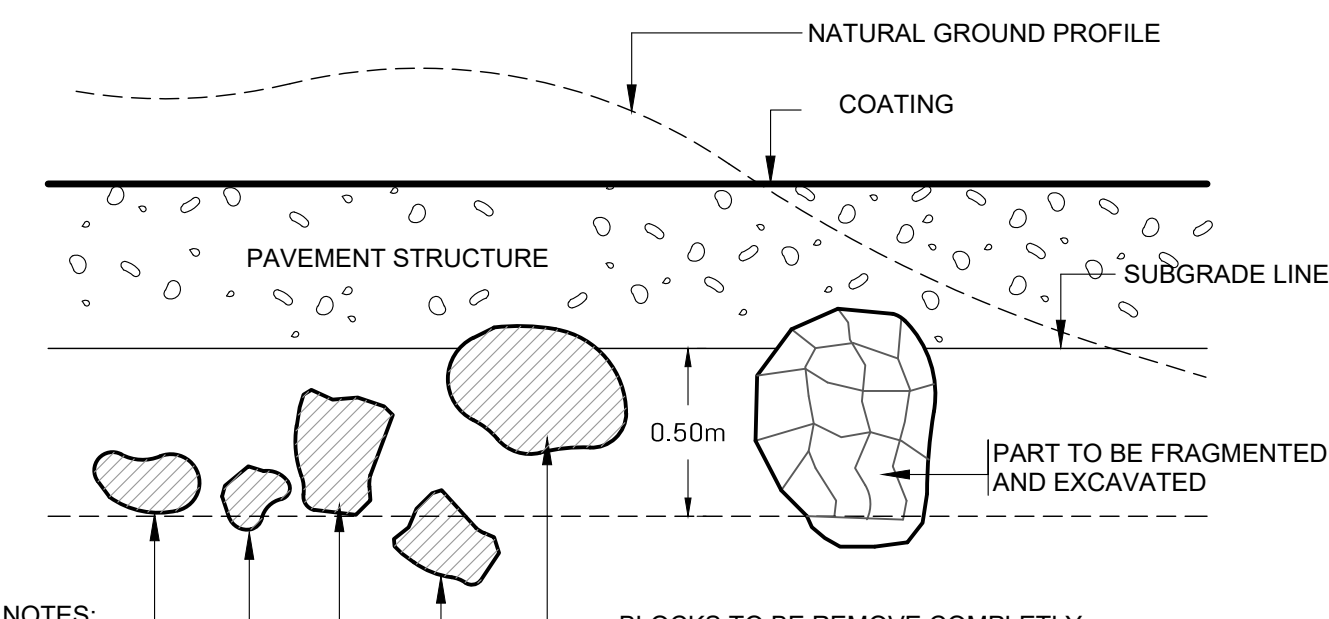

- NOTES:**
- BLOCKS TO BE REMOVE COMPLETELY
 - ALL BLOCKS OVER 250mm DIAMETER PRESENT IN THE FIRST 500 mm UNDER INFRASTRUCTURE LINE MUST BE REMOVED, FRAGMENTED AND EXCAVATED TO 500 mm DEPT.
 - AFTER REMOVING BLOCKS, THE EXCAVATIONS HAVE TO BE RAISED TO DESIGN SUBGRADE LEVELS WITH APPROVED COMPACTABLE ON SITE SOIL.
 - LIFTS OF 300mm THICK, COMPACTED AT 95% MSPDD
 - AS AN ALTERNATIVE TO SUBEXCAVATION, A WOVEN GEOTEXTILE SEPARATOR, SUCH AS TERRATRACK 24-15, AMOCO 2002, MIRAFI 500XL OR EQUIVALENT, MAY BE PLACED OVER SPONGY AREAS PRIOR TO PLACING THE GRANULAR "B" SUB-BASE LAYER.

SUBGRADE PREPARATION DETAIL

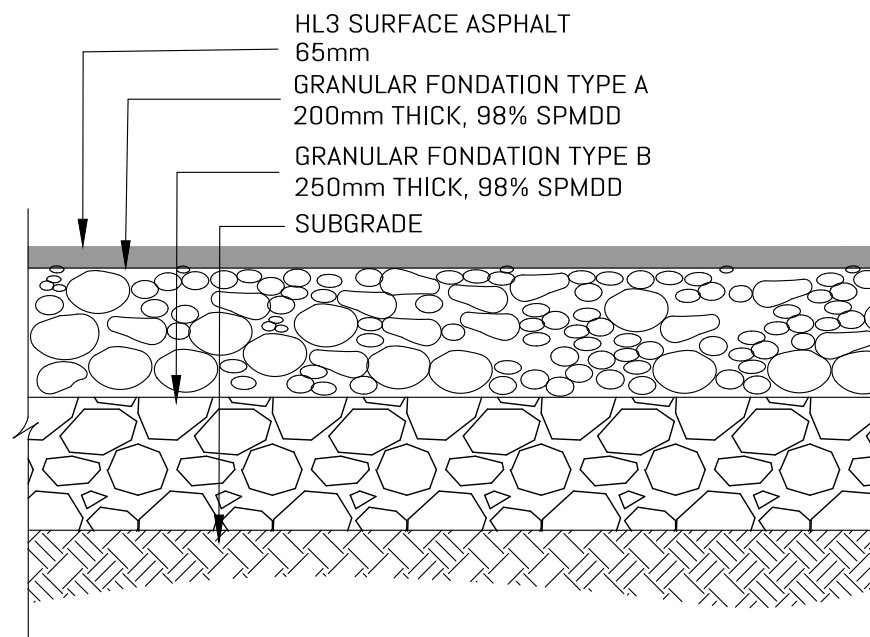

**PARKING AND ACCESS
FOUNDATION ASPHALT SURFACE**
(TO BE VERIFIED BY GEOTECHNICAL ENGINEER)

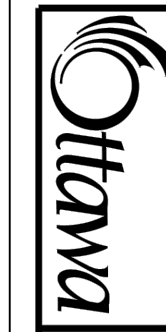

STANDARD TRENCH REINSTATEMENT
IN PAVED SURFACE

DATE: MAY 2001
REV: MARCH 2002
DWG. No.: R10
N.T.S.

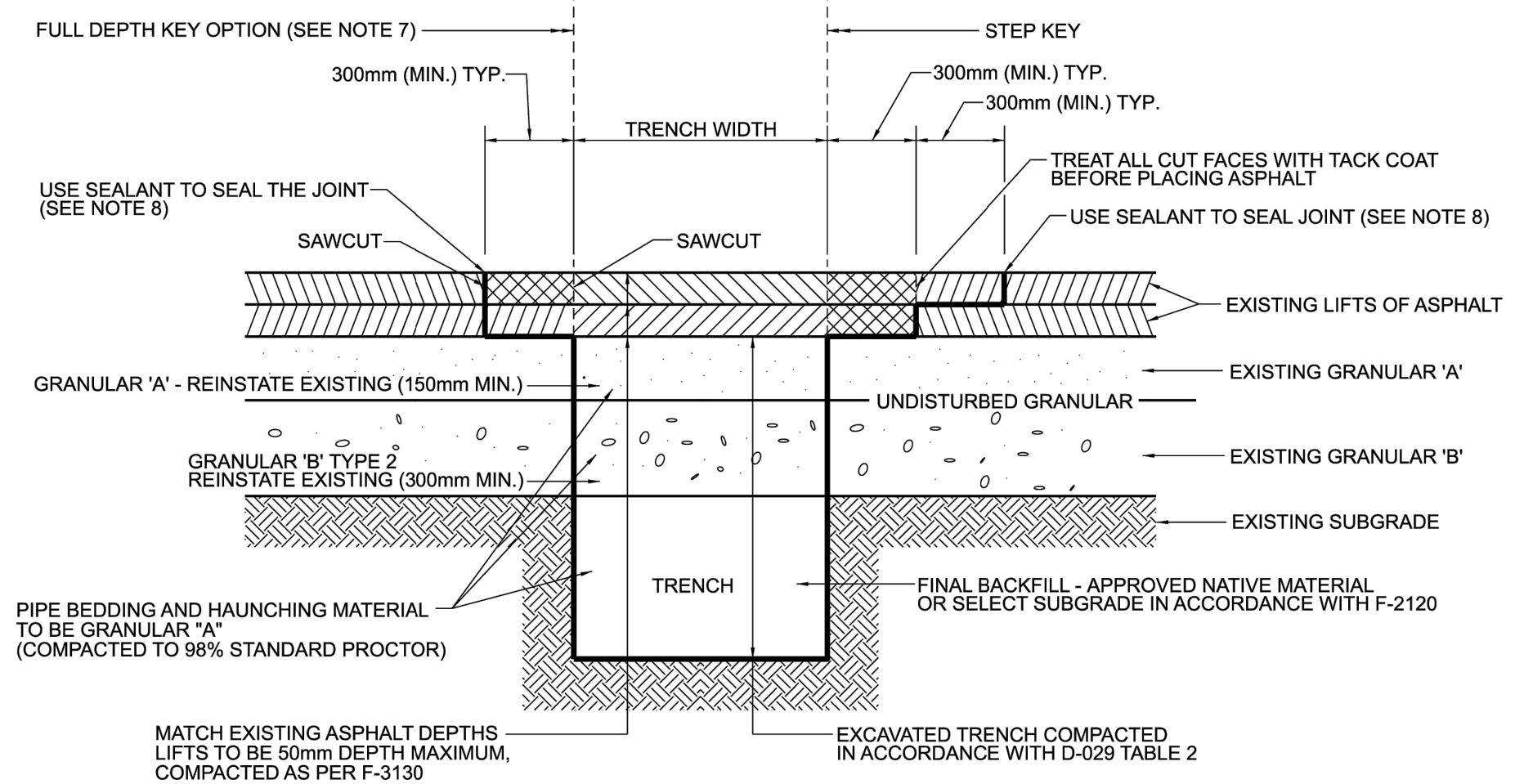

- NOTES:**
- ALL EXISTING ASPHALT TO BE SAW CUT.
 - UNLESS SPECIFIED ELSEWHERE, SURFACE COURSE ASPHALT SUPERPAVE 12.5mm AND BASE COURSE ASPHALT SUPERPAVE 19.0mm IS TO BE USED.
 - UNLESS SPECIFIED ELSEWHERE, ASPHALT MIX SHALL BE LEVEL B (PG58-34) FOR NON-BUS LOCAL ROADS, AND LEVEL D (PG 64-34) FOR ALL OTHER ROADS.
 - UNLESS SPECIFIED ELSEWHERE, WHERE EXISTING PAVEMENT STRUCTURE EXCEEDS 150mm IN DEPTH, ASPHALT REINSTATEMENT SHALL BE 150mm AND GRANULAR "A" FOR THE REMAINDER.
 - UNLESS SPECIFIED ELSEWHERE, WHERE AN UNDERLYING LAYER OF CONCRETE PAVEMENT EXISTS, REINSTATEMENT SHALL CONSIST OF 150mm LEVEL B (PG58-34) COMPACTED IN LIFTS.
 - UNLESS SPECIFIED ELSEWHERE, HOT MIX ASPHALT PLACEMENT AND CONSTRUCTION SHALL BE IN ACCORDANCE WITH F-3130.
 - STEP KEY REINSTATEMENT TO BE IMPLEMENTED UNLESS FULL DEPTH KEY OPTION APPROVED BY THE CITY.
 - ALL EDGES TO BE ROUTED AND SEALED WITH A BEAD OF HOT RUBBERIZED ASPHALT JOINT SEALING COMPOUND.

**THIS DOCUMENT MUST
NOT BE USED FOR
CONSTRUCTION**

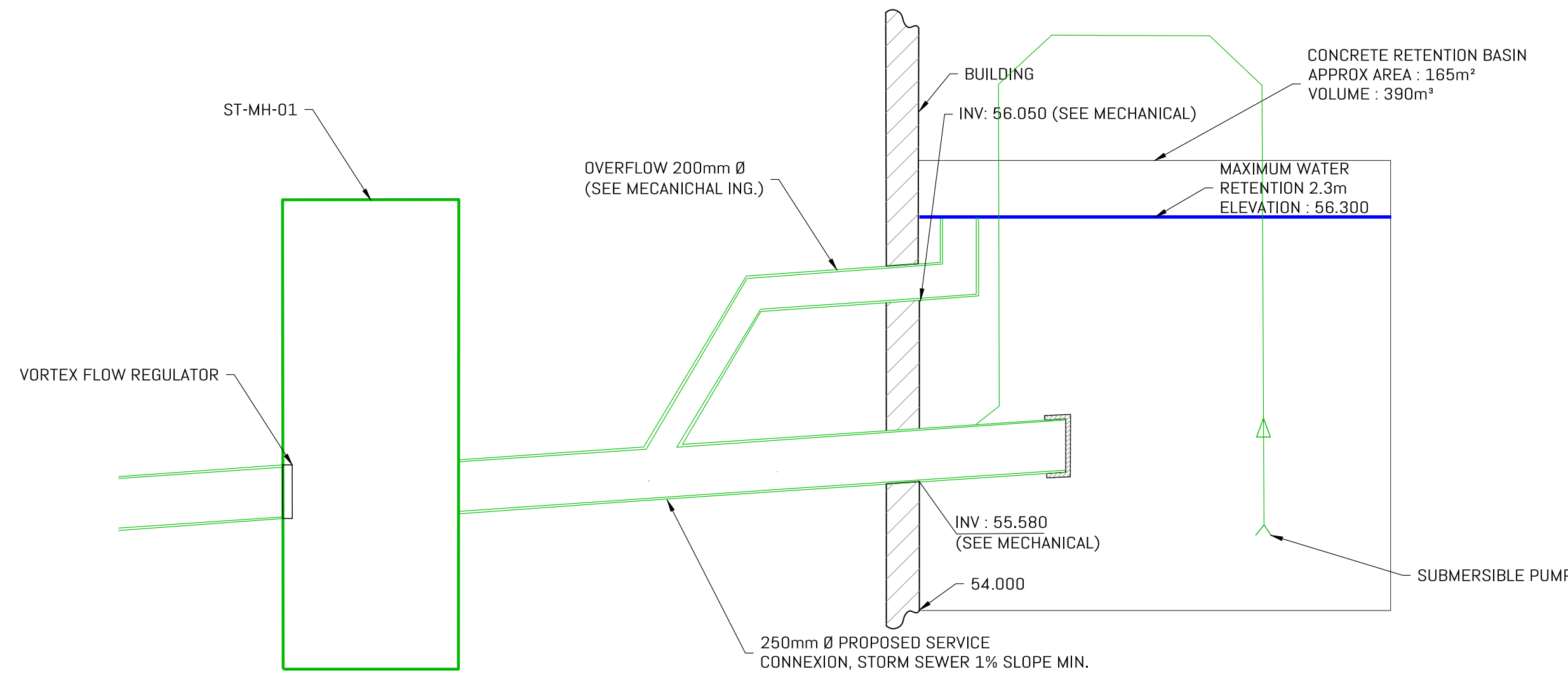

REV	DESCRIPTION	PAR	DATE
C	FOR SITE PLAN APPLICATION REV.01	B.B.	2026-02-05
B	FOR SITE PLAN APPLICATION	B.B.	2025-12-11
A	FOR UDRP	B.B.	2025-09-15

CLIENT
BÂTIMO DÉVELOPPEMENT INC.
SUITE 400-6485, RUE DORIS-LUSSIER
BOISBRIAND, QUÉBEC
J7H 0E8

PROJET
LIB ORLÉANS
500 FAMILLE-CÔTÉ AVENUE
OTTAWA

135, boulevard de Sainte-Adèle, Sainte-Adèle (Qc) J8B 0L4
T. 450 227 1857
info@equipe-laurence.ca | equipe-laurence.ca

SCAUN

TITRE DU PLAN
STANDARD SECTIONS AND DETAILS

ÉCHELLE
AUCUNE ÉCHELLE

ÉQUIPE DE PROJET
L.-C. TELLIER, techn.
J. FURTADO, ing.
V. MERCIER, ing.

PRÉPARÉ PAR
B. BRAY, ing.

DOSSIER NO
601401
FICHER
C-205.dwg
C-205

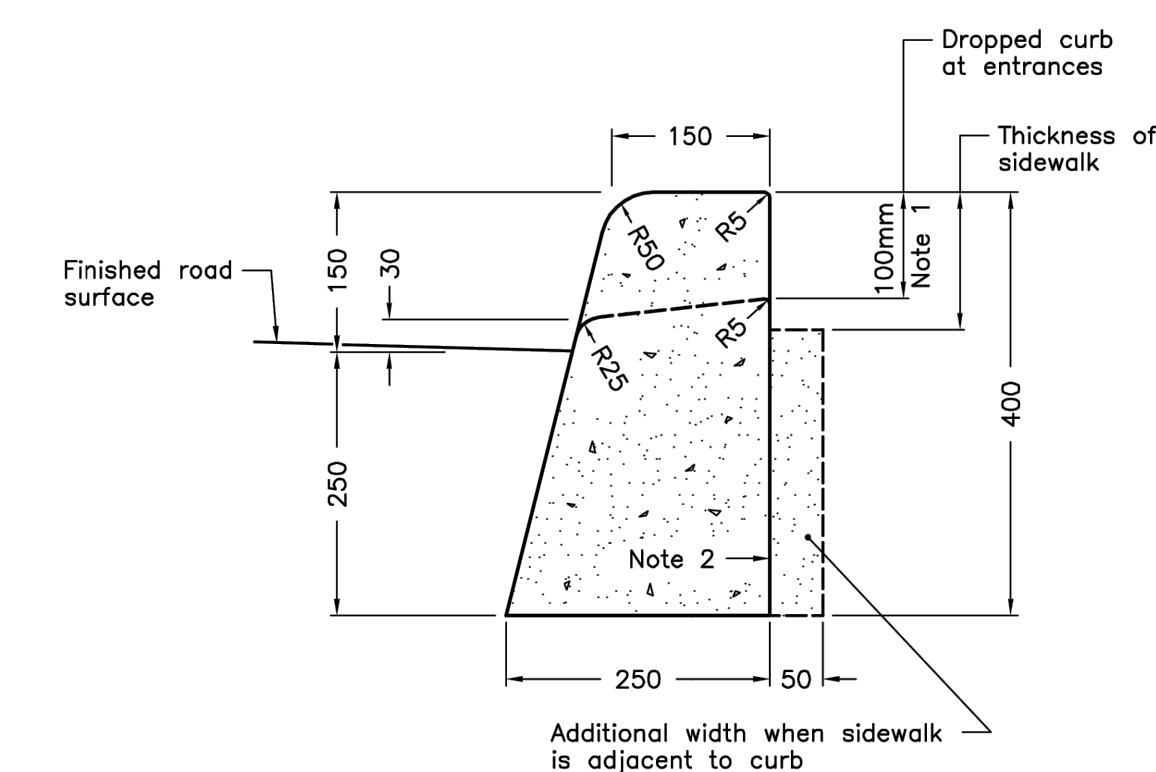

- NOTES:**
- When sidewalk is continuously adjacent, the dropped curb at entrances shall be reduced to 75mm.
 - For slipforming procedure a 5% batter is acceptable.
 - Treatment at entrances shall be according to OPSD 351.010.
 - Outlet treatment shall be according to the OPSD 610 Series.
 - The transition from one curb type to another shall be a minimum length of 3.0m, except in conjunction with guide rail where it shall be according to the OPSD 900 Series.
 - All dimensions are in millimetres unless otherwise shown.

ONTARIO PROVINCIAL STANDARD DRAWING
Nov 2012 Rev 2
CONCRETE BARRIER CURB
OPSD 600.110

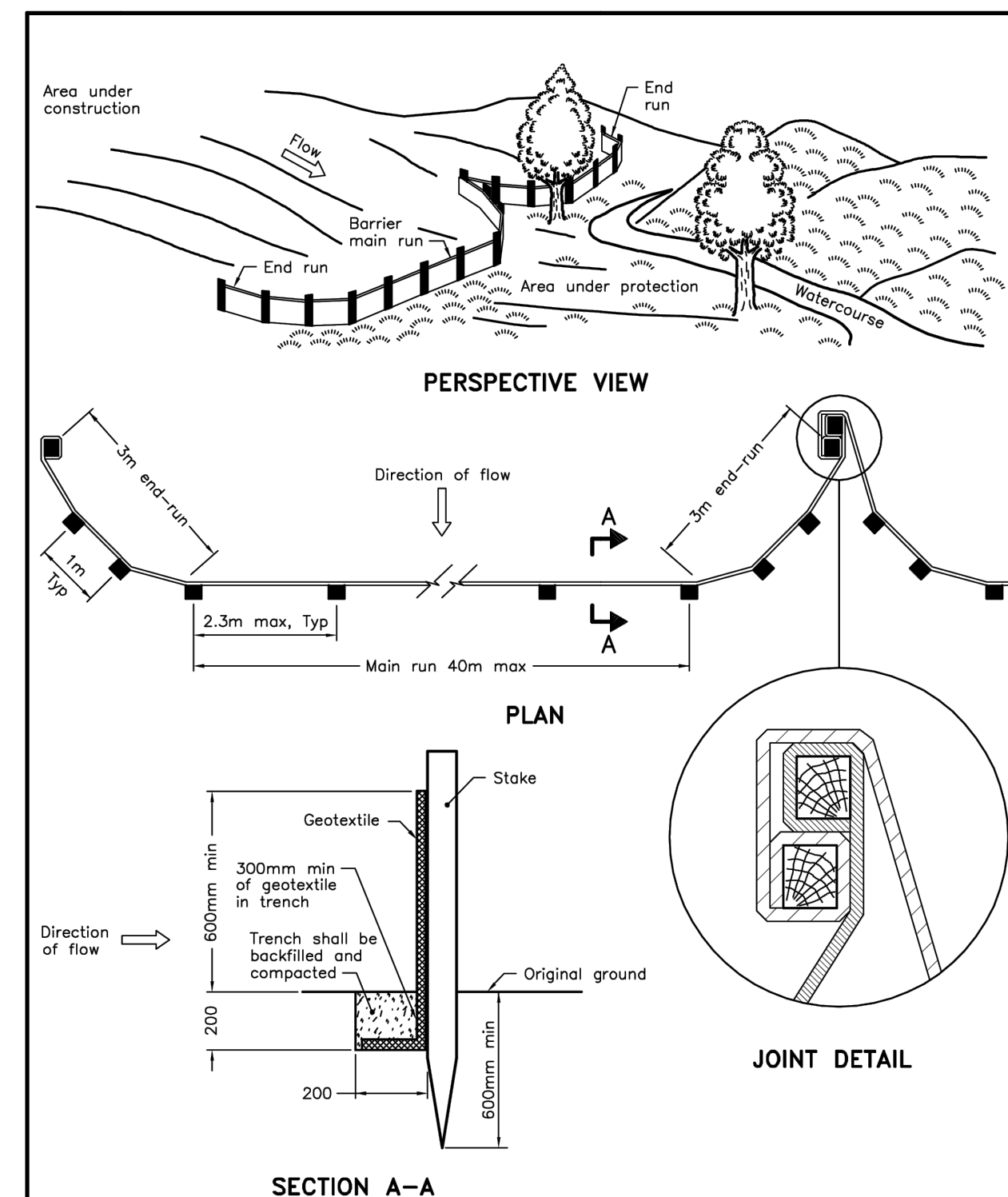

NOTE:
A All dimensions are in millimetres unless otherwise shown.

ONTARIO PROVINCIAL STANDARD DRAWING
Nov 2015 Rev 2
**LIGHT-DUTY
SILT FENCE BARRIER**
OPSD 219.110

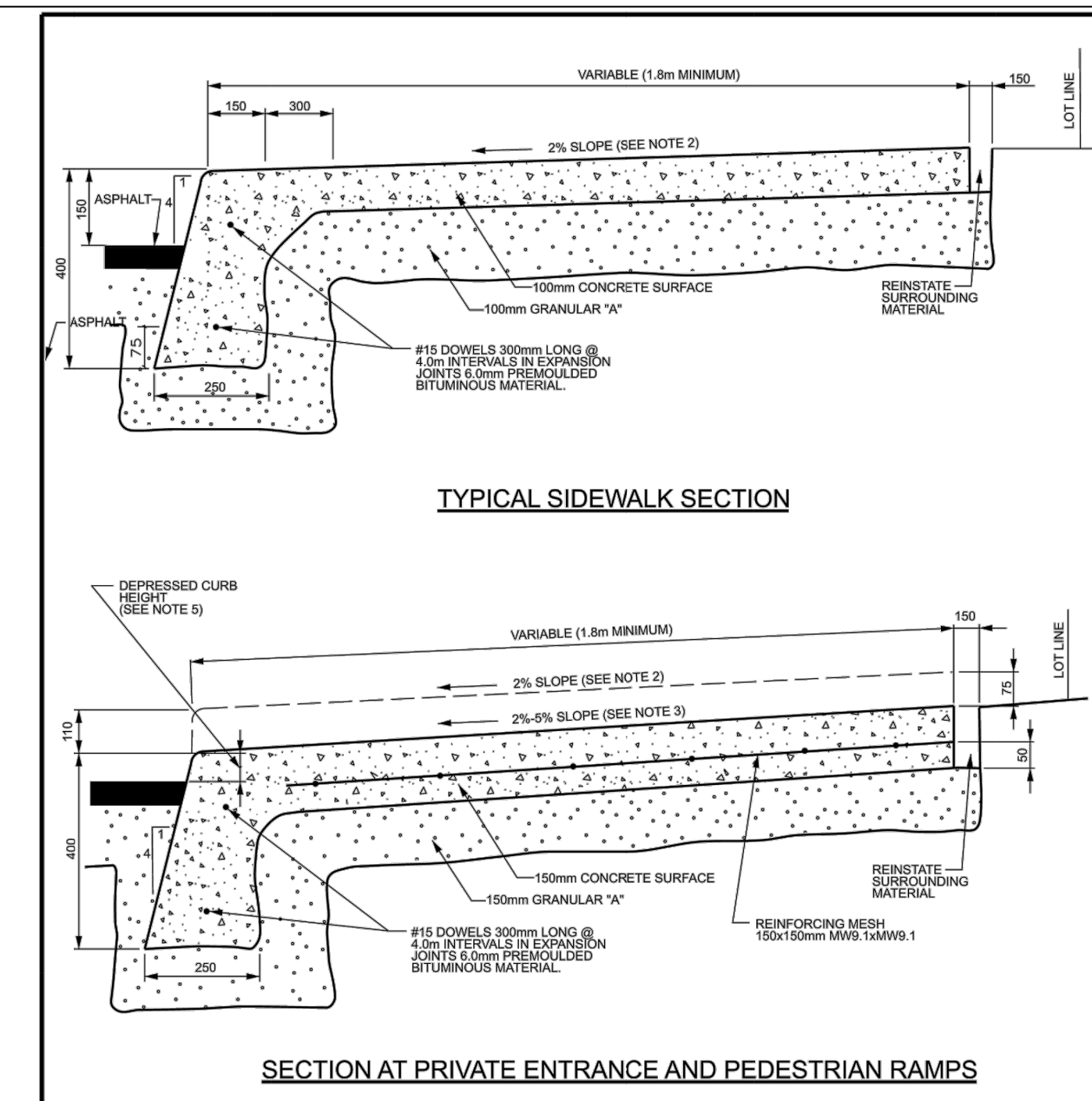

- NOTES:**
- ALL DIMENSIONS ARE IN MILLIMETRES UNLESS SHOWN OTHERWISE.
 - THE MAXIMUM SLOPE IS NOT TO EXCEED 2%.
 - FOR CURB RAMPS, SLOPE OF 2% TO 5% MAXIMUM 6%.
 - EXPANSION AND DUMMY JOINTS AS PER SCS.
 - DEPRESSED CURB HEIGHT - FOR PEDESTRIAN CURB RAMPS 0 TO 6 mm AND FOR PRIVATE ENTRANCES 0 TO 13 mm.

DATE: MAY 2001
REV. DATE: MAY 2021
DWG. No.: SC2
**MONOLITHIC CONCRETE CURB
AND SIDEWALK**

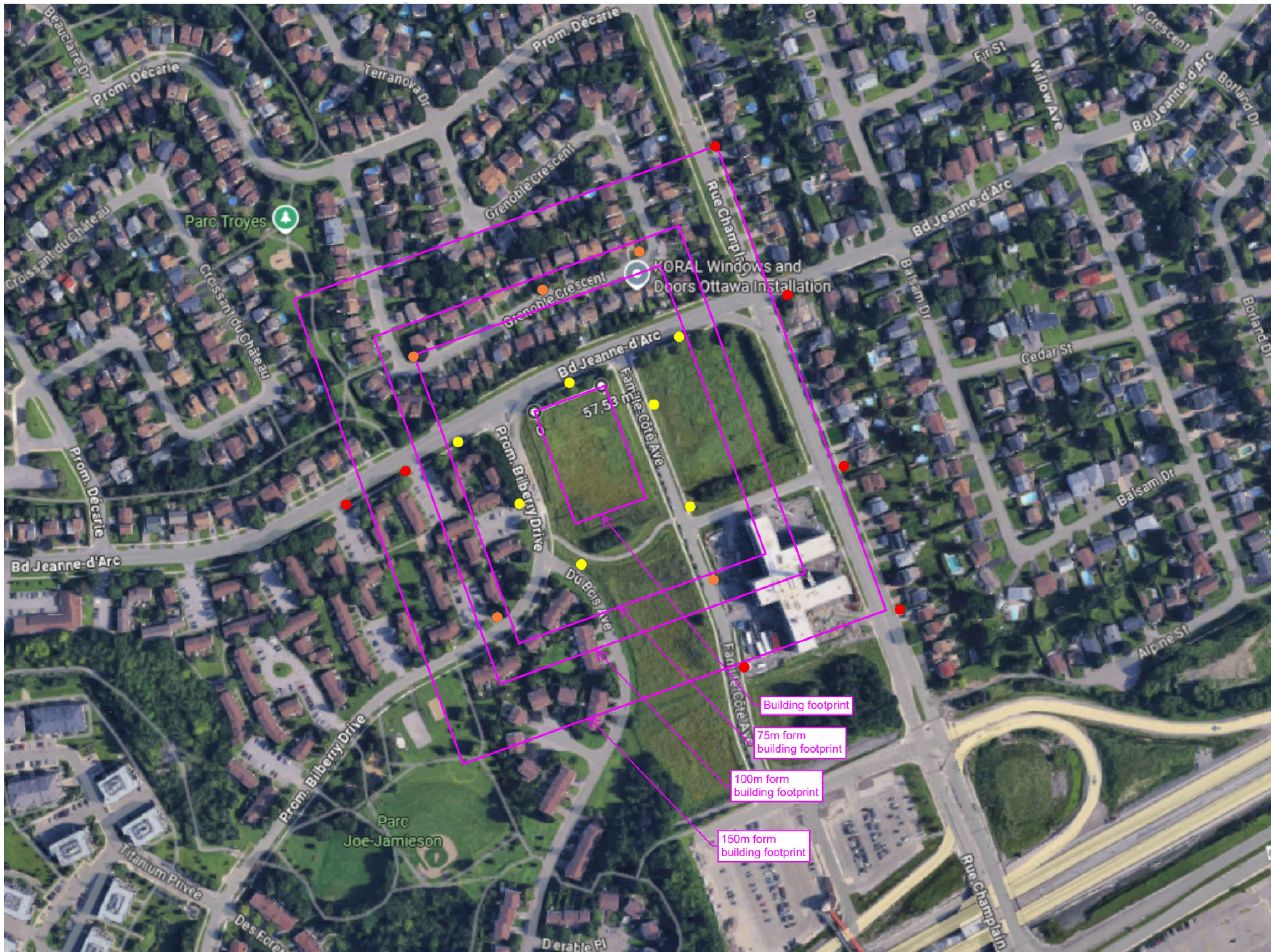

THIS DOCUMENT MUST
NOT BE USED FOR
CONSTRUCTION

REV	DESCRIPTION	PAR	DATE
C	FOR SITE PLAN APPLICATION REV.01	B.B.	2026-02-05
B	FOR SITE PLAN APPLICATION	B.B.	2025-12-11
A	FOR UDRP	B.B.	2025-09-15

CLIENT
 BÂTIMO DÉVELOPPEMENT INC.
 SUITE 400-6485, RUE DORIS-LUSSIER
 BOISBRIAND, QUÉBEC
 J7H 0E8

PROJET
 LIB ORLÉANS
 500 FAMILLE-CÔTÉ AVENUE
 OTTAWA



135, boulevard de Sainte-Adèle, Sainte-Adèle (QC) J8B 0J4
 T. 450 227 1857
 info@equipeaurence.ca | equipeaurence.ca

SCÉAU



TITRE DU PLAN
 FIRE HYDRANT COVERAGE MAP

ÉCHELLE
 AUCUNE ÉCHELLE

ÉQUIPE DE PROJET L.-C. TELLIER, techn. J. FURTADO, ing. V. MERCIER, ing.	DOSSIER NO 601401
	FICHER C-206.dwg

PRÉPARÉ PAR
 B. BRAY, ing.

C-206