

**GENERAL NOTES:**  
 1. MOLOK CONTAINERS MUST BE A MINIMUM 500mm FROM ANY WALL OR STRUCTURE.  
 2. MOLOK BINS SHOULD BE PLACED 300mm FROM EACH OTHER (MEASURED FROM THE CONTAINER TOP).  
 3. MOLOK CONTAINERS MUST BE LOCATED WITHIN 7.0m FROM WHERE THE COLLECTION VEHICLE WILL ACCESS THEM.  
 4. THE AREA ABOVE THE MOLOK CONTAINERS MUST BE FREE OF ANY OVERHEAD OBSTACLES, INCLUDING TREES, UTILITY LINES, LIGHTING, ETC.  
 5. THERE CANNOT BE UNDERGROUND UTILITIES OR SERVICES WITHIN 300mm OF ANY MOLOK CONTAINER.

**MOLOK STANDARD TRUCK TEMPLATE**

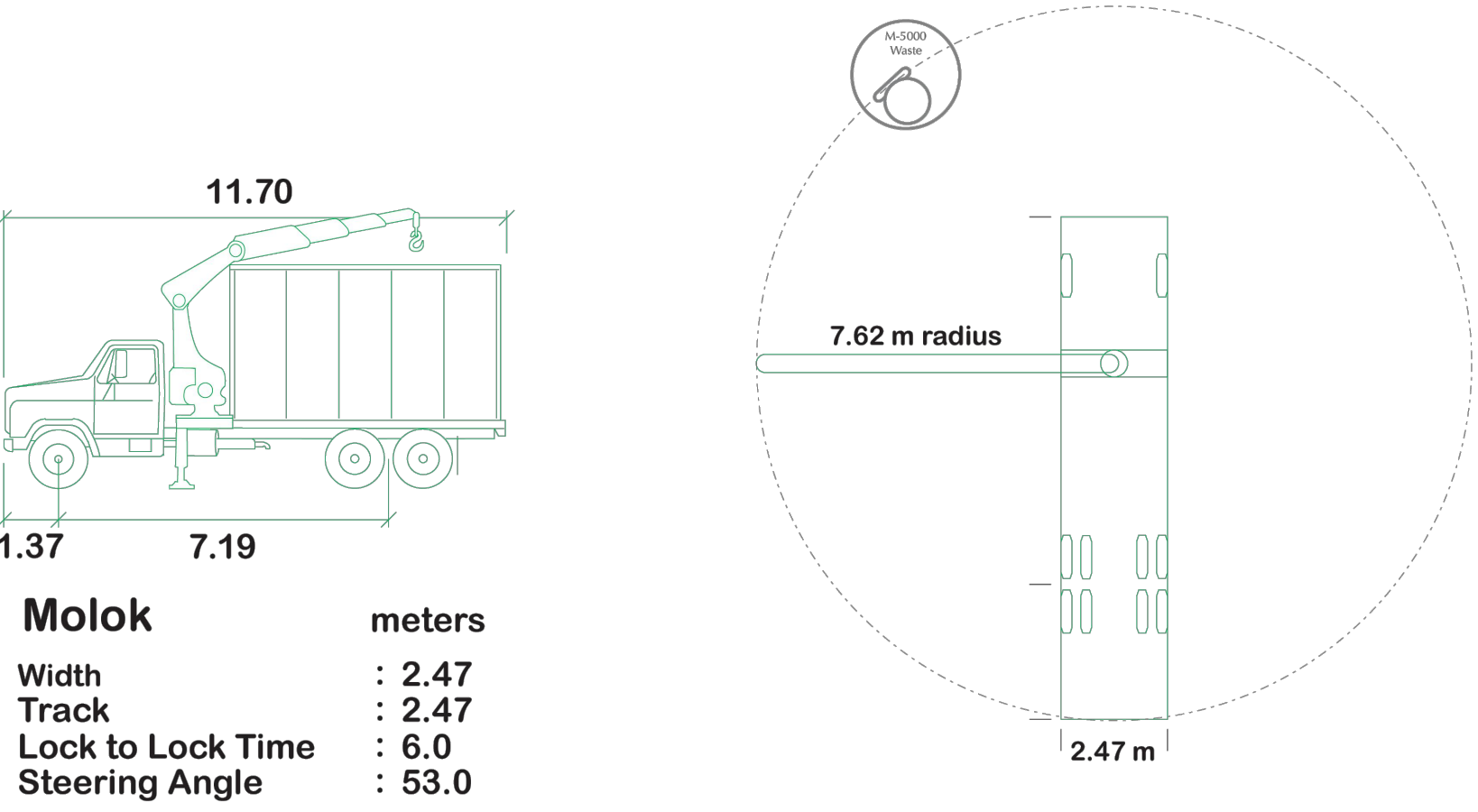

**Collection Truck Crane Reach**



**Chick-fil-A**  
 5200 Buffington Road  
 Atlanta, Georgia 30349-2998

exp Services Inc.  
 T: +1.905.793.9800 | F: +1.905.793.0641  
 1595 Clark Boulevard  
 Brampton, ON L6T 4V1  
 Canada  
 www.exp.com



• BUILDINGS • EARTH & ENVIRONMENT • ENERGY •  
 • INDUSTRIAL • INFRASTRUCTURE • SUSTAINABILITY



**CHICK-FIL-A**  
**COLLEGE SQUARE**  
 1984 Baseline Road  
 Ottawa, ON

**FSR#30088**

BUILDING TYPE / SIZE: IP02 SE  
 RELEASE: XXXXXXXXX

**REVISION SCHEDULE**

NO.	DATE	DESCRIPTION
A	2025-09-15	FOR SPA

CITY # SPA xx REGION # Cxx  
 CONSULTANT PROJECT # BRM0023002042-WO  
 PROJECT STATUS SPA  
 DATE AUGUST 2025  
 DRAWN BY T.M.

Information contained on this drawing and in all digital files produced for above named project may not be reproduced in any manner without express written or verbal consent from authorized project representatives.

SHEET  
 MOLOK DETAILS

SHEET NUMBER

**C9.5M**

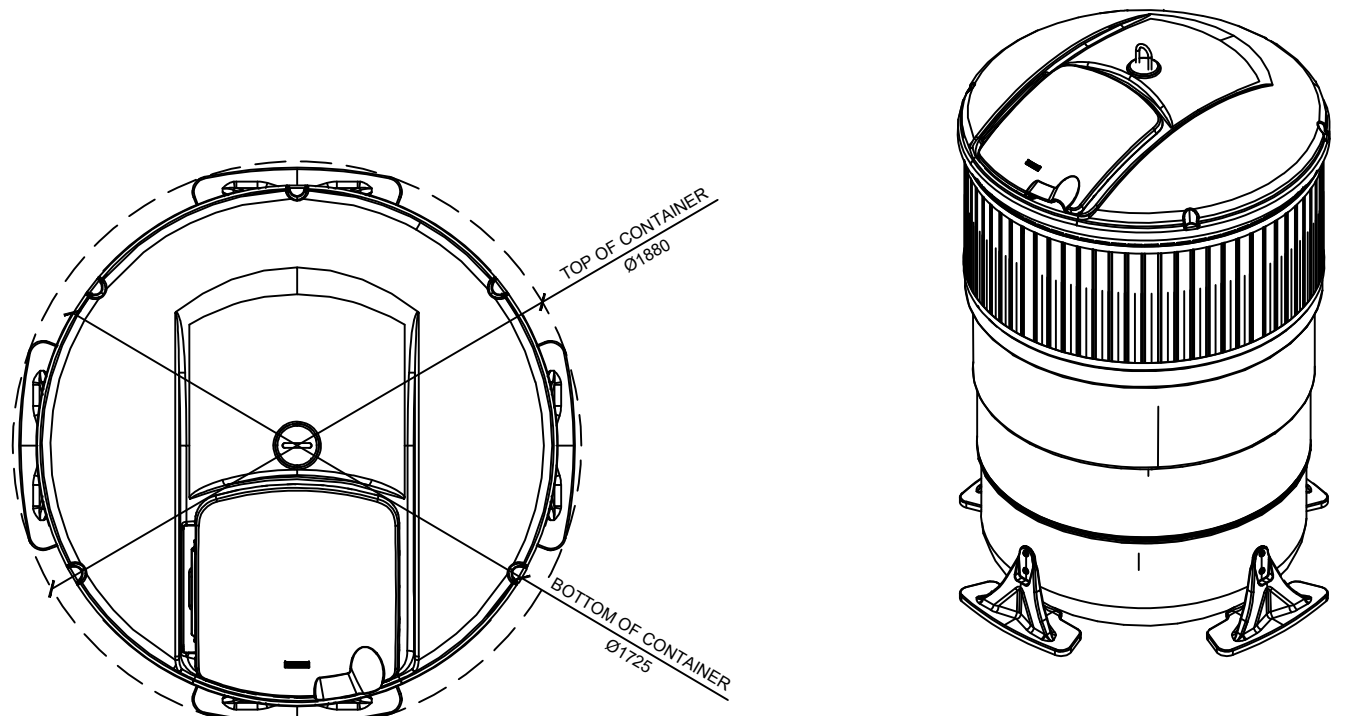
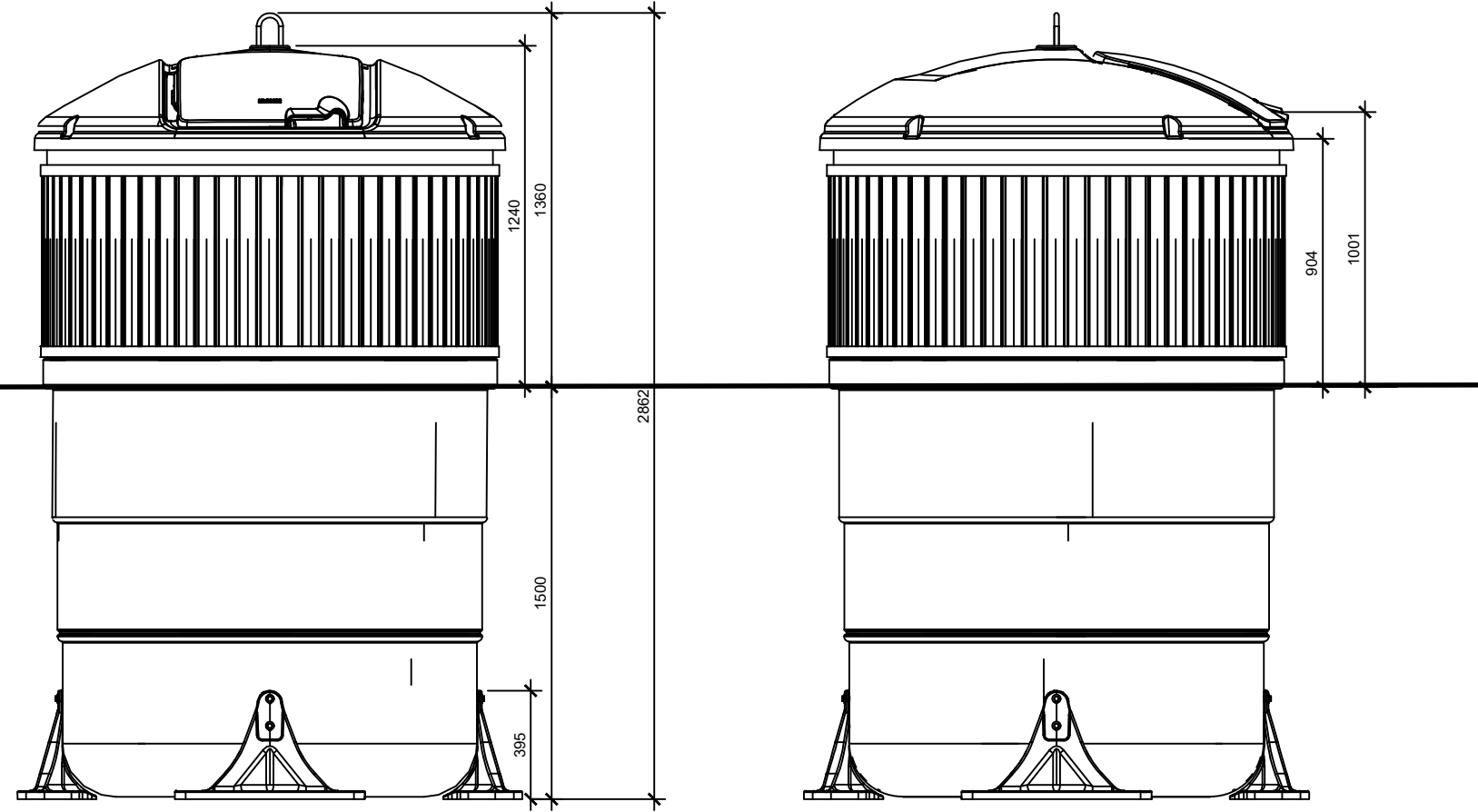

WHERE 3 M-5000 UNITS ARE INSTALLED:  
 2 UNITS FOR TRASH:  
 - QUICK SYSTEM  
 - STANDARD, BLACK LID  
 - STANDARD OPENING  
 - SEMI-HARD LIFTING BAG  
 - FRAMING: STANDARD MATTE BLACK  
 1 UNIT FOR CARDBOARD:  
 - QUICK SYSTEM  
 - HINGE, BLUE LID  
 - STANDARD OPENING  
 - REGULAR LIFTING BAG  
 - FRAMING: STANDARD MATTE BLACK

**M-5000**

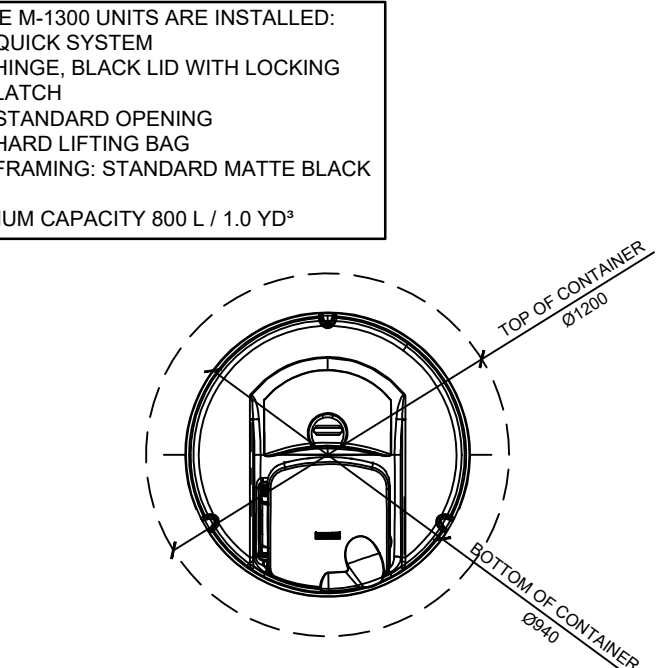
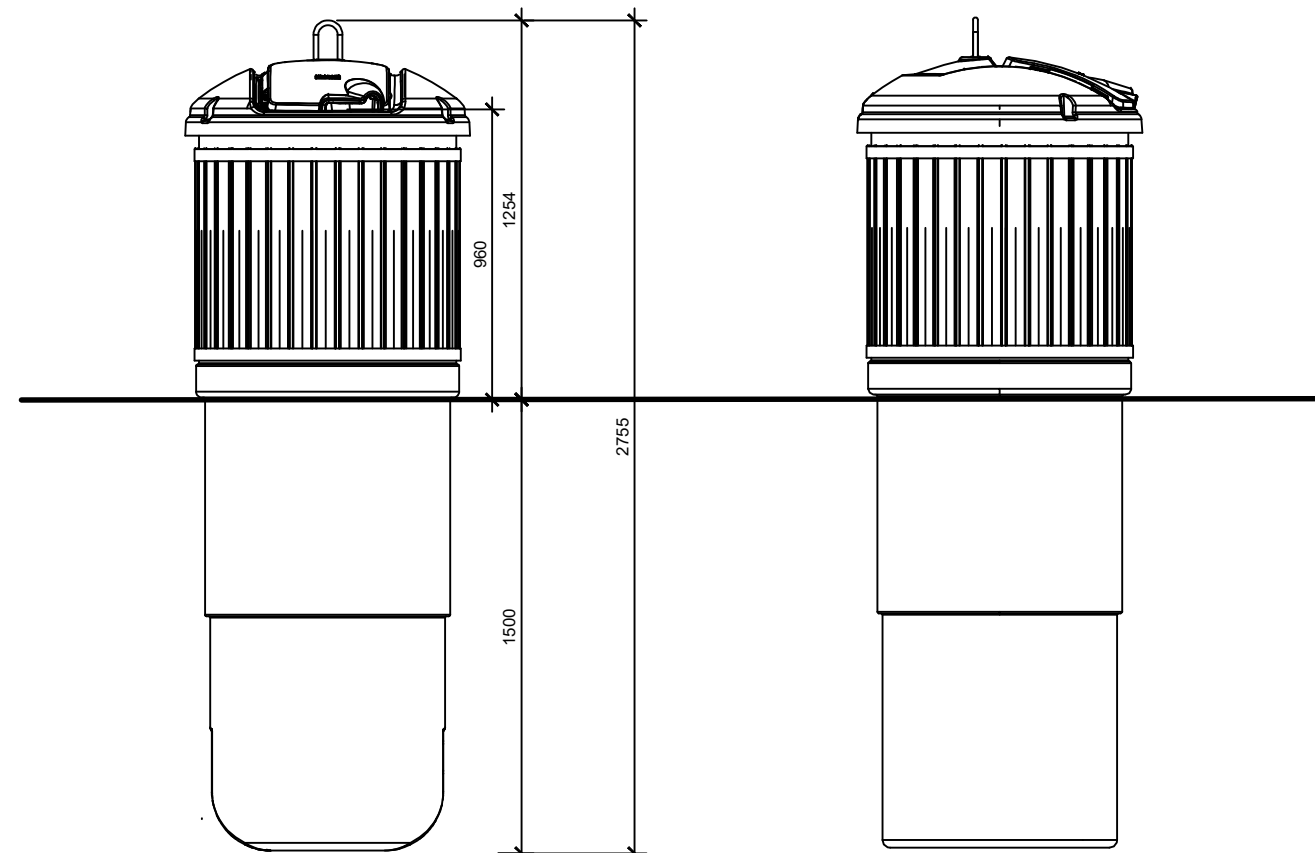

WHERE M-1300 UNITS ARE INSTALLED:  
 - QUICK SYSTEM  
 - HINGE, BLACK LID WITH LOCKING LATCH  
 - STANDARD OPENING  
 - HARD LIFTING BAG  
 - FRAMING: STANDARD MATTE BLACK  
 MAXIMUM CAPACITY 800 L / 1.0 YD<sup>3</sup>

**M-1300**  
**FOR ORGANIC WASTE**  
**WHERE REQUIRED BY JURISDICTION**



**SAMPLE MOLOK INSTALLATION**