

PROPOSED RESIDENTIAL APARTMENT BUILDING

LOT DEVELOPMENT SITE

222 BASELINE ROAD

PART OF LOT 72

R-PLAN 526

CITY OF OTTAWA

STORM WATER MANAGEMENT BRIEF

REPORT No. R-824-74 (REV. #2)

SEPTEMBER 30, 2025

T.L. MAK ENGINEERING CONSULTANTS LTD.

APRIL 2025

REFERENCE FILE NUMBER 824-74

Introduction

The proposed four (4) storey mid-rise multi-unit building site is located on the south side of Baseline Road, situated east of Lexington Street and west of Morley Boulevard. Its legal property description is Part of Lot 72 Registered Plan 526 in City of Ottawa (Ward 16 - River). Presently, the property is occupied by (1 ½) storey brick building with asphalt laneway located east of the existing house. The municipal address of the property is referenced as 222 Baseline Road.

The site development area under consideration is approximately 691.58 metres. This site is proposed for the development of a (4) storey multi-unit residential apartment building. The building contains eighteen (18) residential units.

In addition to the residential apartment building proposed for this lot, other development features of the site are interlock walkway along the north, west and south side of the building, soft landscaping at the front yard, side yards and rear yard, bike racks and amenity area at the rear of the property, etc. to meet City of Ottawa requirements for urban developments. Refer to Appendix A for site plan details as shown on Dwg. No. A2 prepared by the owner's Architects.

As part of the conditions for site plan application, the owner is required to submit a Storm Water Management (SWM) Brief and design to demonstrate that the post development storm water peak flows are controlled to the satisfaction of the City of Ottawa Development Review Group.

This Storm Water Management Brief will provide the City of Ottawa with Stormwater Management mitigating/attenuation measures proposed for this proposed site plan application.

For storm-drainage criteria set by the staff at the City of Ottawa's Engineering Department, the allowable post-development runoff release rates shall not exceed the five (5)-Year pre-development conditions. The allowable pre-development runoff coefficient to be used is the lesser of the calculated "C" existing value = 0.4 or $C_{allow} = 0.5$ maximum. If the uncontrolled storm-water runoff exceeds the specified requirements, the on-site storm-water management (SWM) control measures are necessary. The post-development runoff coefficient for this site is estimated at $C = 0.78$ which exceeds the calculated pre-development allowable $C_{pre} = 0.40$ criteria for the Baseline Road storm sewer without on-site SWM control. Therefore, SWM measures are required. Refer to attached Drainage Area Plan (Figure 1) as detailed in Appendix A. For Pre and Post site development characteristics, refer also to the Storm Drainage Area Plan Dwg. No. 824-74 D-1 for details.

This brief will address and detail the storm-water management control measures required to develop this property. Based on the Proposed Lot Grading and Servicing Plan (Dwg. No. 824-74 G-1), and on the Proposed Rooftop Storm-water Management Plan (Dwg. #824-74 SWM-1), the storm water of this lot will be controlled on-site only by the building's flat rooftop.

The storm-water management calculations that follow will detail the extent of on-site SWM control to be implemented and the storage volume required on-site to attain where possible the appropriate runoff release that will conform to the City's established drainage criteria and review requirements.

Existing Site Conditions and Servicing

The existing property under consideration is approximately ±0.0692 ha. in size. Presently, a (1 ½) storey brick house with frame addition is located at the east half of the property. Approximately, 71% of the site is found to be grass/landscaped covered with the exception of an asphalt driveway, the existing dwelling, porches at front and rear of house and interlock walkway situated at the front of the existing house.

Terrain of the development lot under consideration slopes primarily from west to east (front to rear) at an approximate average gradient of ±1.7% over a distance of ±33.0 m. Existing front to rear drainage of the site (±691.58 m²) is found to be directing flow to the rear yard and outlet onto the existing Lexington Street roadway ditch. A Google image and aerial photography of these current pre-development conditions of the site is provided in Appendix B of this report for reference. Also refer to the topographical survey details for this property prepared by Stantec Geomatics Ltd. and as shown on their “Topographical Survey Plan” (Proj. No. 161614544-111 completed on March 16, 2022 and revised on September 25, 2024) found in Appendix B for details.

Site Data

1. Development Property Area

Post-Development Site Area Characteristics

Development Lot Area	= 691.58 m ²
Roof Surface Area	= 386.95 m ²
Concrete/Interlock Area	= 170.33 m ²
Riverstone Area	= 23.35 m ²
Grass Area	= 110.95 m ²

$$C = \frac{(386.95 \times 0.9) + (170.33 \times 0.9) + (23.35 \times 0.8) + (110.95 \times 0.2)}{691.58}$$

$$C = \frac{542.422}{691.58}$$

$$C = 0.784$$

Say “C” = 0.78

Therefore, the average post-development “C” for this site is 0.78.

2. Controlled Area Data (NODE #1, NODE #2 and NODE #3)

Roof Surface Area	= 350.03 m ²
Total Storm-water Controlled Area	= 350.03 m ²

$$C = \frac{(350.03 \times 0.9)}{350.03}$$

$$C = \frac{315.027}{350.03}$$

$$C = 0.9$$

Say "C" = 0.9

Therefore, the post-development "C" for the controlled storm-water drainage area (rooftop) is 0.9.

3. Uncontrolled Area Data (NODE #4 and NODE #5)

Roof Area	= 36.92 m ²
Grass Area	= 110.95 m ²
Riverstone Area	= 23.35 m ²
Concrete/Interlock Area	= 170.33 m ²
Total Storm-water Uncontrolled Area	= 341.55 m ²

$$C = \frac{(170.33 \times 0.9) + (110.95 \times 0.2) + (23.35 \times 0.8) + (36.92 \times 0.9)}{341.55}$$

$$C = \frac{227.395}{341.55}$$

$$C = 0.666$$

Say "C" = 0.67

Therefore, the post-development "C" for the uncontrolled stormwater drainage area of 341.55 m² from this site is C = 0.67.

The total tributary area consisting of approximately 341.55 square meters will be outletting off-site uncontrolled from this property which is also the surface area draining to the front and rear of the lot and outletting to the Lexington Street and Baseline Road road right-of-way.

The uncontrolled drainage area is 341.55 m² and the controlled drainage area from the available flat rooftop is 350.03 m² which totals to 691.58 m².

The SWM area to be controlled is 350.03 m². Refer to Dwg. No. 824-74 D-1 and the attached "Drainage Area Plan" in Figure 1 of Appendix A for further details.

Pre-Development Flow Estimation

Maximum allowable off-site flow: five (5)-Year Storm

NODE #101

Pre-Development Site Area Characteristics

Development Lot Area	= 691.58 m ²
Asphalt Area	= 49.74 m ²
Roof Area	= 145.19 m ²
Grass Area	= 492.84 m ²
Concrete Area	= 3.81 m ²

$$C_{5pre} = \frac{(145.19 \times 0.9) + (49.74 \times 0.9) + (492.84 \times 0.2) + (3.81 \times 0.9)}{691.58}$$

$$C_{5pre} = \frac{277.434}{691.58}$$

$$C_{5pre} = 0.401$$

Say " C_{5pre} " = 0.40 < C_{5allo} = 0.5

∴ Use C_{pre} = 0.40 allowable for redevelopment

$T_c = D/V$ where $D = 33.0$ m, $\Delta H = 0.55$ m, $S = 1.7\%$, and $V = 1.2$ feet/second = 0.37 m/s

Therefore,

$$T_c = \frac{33.0 \text{ m}}{0.37 \text{ m/s}}$$

$T_c = 1.49$ minutes

Use $T_c = 10$ minutes

$I_5 = 104.20$ mm/hr [City of Ottawa, five (5)-Year storm]

Using the Rational Method

$$Q_{5pre} = 2.78 (0.40) (104.20) (0.0692)$$

$$Q_{5pre} = 8.02 \text{ L/s}$$

Therefore, the total allowable flow off-site is 8.02 L/s.

The pre-development flow of the five (5)-Year and 100-Year storm event draining off-site from the lot is as follows:

Where, $T_c = 10$ minutes

$$Q_{5pre} = 2.78 \text{ CIA}$$

$$C_{5pre} = \frac{277.434}{691.58}$$

$$C_{5pre} = 0.401$$

Say, $C_{5pre} = 0.40$ draining off-site.

$$Q_{5pr} = 2.78 (0.40)(104.20)(0.0692)$$

$$Q_{5pre} = 8.02 \text{ L/s}$$

$$C_{100pre} = \frac{(145.19 \times 1.0) + (49.74 \times 1.0) + (492.84 \times 0.2 \times 1.25) + (3.81 \times 1.0)}{691.58}$$

$$C_{100pre} = \frac{321.95}{691.58}$$

$$C_{100pre} = 0.466$$

Say, $C_{100pre} = 0.47$ draining off-site.

$$Q_{100pre} = 2.78 (0.47)(178.6)(0.0692)$$

$$Q_{100pre} = 16.15 \text{ L/s}$$

Therefore, under the current site conditions the 5-Year pre-development flow is estimated at 8.02 L/s and the 100-Year pre-development flow is estimated at 16.15 L/s.

Refer to Google image and aerial photography of these current pre-development conditions of the site provided in Appendix B of this report for reference.

Post-Development Flow Estimation

Uncontrolled Drainage Areas – ENTIRE LOT

The post-development flow of the five (5)-Year and 100-Year storm event draining off-site from the lot uncontrolled is as follows:

Where, $T_c = 10$ minutes

Node #4 and Node #5

$$Q_{5\text{post}} = 2.78 \text{ CIA}$$

Post-development Area Draining uncontrolled off-site of this lot is:

Roof Area	= 36.92 m ²
Riverstone Area	= 23.35 m ²
Grass Area	= 110.95 m ²
Concrete/Interlock Area	= 170.33 m ²

$$A_{\text{total}} = 341.55 \text{ m}^2$$

$$C_{5\text{post}} = \frac{(170.33 \times 0.9) + (110.95 \times 0.2) + (23.35 \times 0.8) + (36.92 \times 0.9)}{341.55}$$

$$C_{5\text{post}} = \frac{227.395}{341.55}$$

$$C_{5\text{po}} = 0.666$$

Say " $C_{5\text{pos}}$ " = 0.67 draining towards Baseline Road and Lexington Street (ROW) uncontrolled.

$$Q_{5\text{post}} = 2.78 (0.67)(104.20)(0.03416)$$

$$Q_{5\text{pos}} = 6.63 \text{ L/s}$$

$$C_{100\text{post}} = \frac{(170.33 \times 1.0) + (110.95 \times 0.2 \times 1.25) + (23.35 \times 1.0) + (36.92 \times 1.0)}{341.55}$$

$$C_{100\text{post}} = \frac{258.338}{341.55}$$

$$C_{100\text{post}} = 0.756$$

Say, $C_{100\text{post}} = 0.76$ draining towards Baseline Road and Lexington Street (ROW) uncontrolled.

$$Q_{100\text{post}} = 2.78 (0.76)(178.6)(0.03416)$$

$$Q_{100\text{post}} = 12.90 \text{ L/s}$$

i. Uncontrolled Drainage Area to Baseline Road (R.O.W.) – Node #4

Roof Area	= 10.68 m ²
Interlock/Concrete Area	= 89.74 m ²
Grass Area	= 86.72 m ²
Riverstone Area	= 15.04 m ²

$$A_{\text{total (to Baseline Road)}} = 202.18 \text{ m}^2$$

5-Year Event

$$C_5 = \frac{(89.74 \times 0.9) + (10.68 \times 0.9) + (15.04 \times 0.8) + (86.72 \times 0.2)}{202.18}$$

$$C_5 = \frac{119.754}{202.18}$$

$$C_5 = 0.592$$

$$\text{Say "C}_5\text{"} = 0.59$$

$$Q_5 = 2.78 (0.59)(104.20)(0.0202)$$

$$Q_5 = 3.45 \text{ L/s}$$

100-Year Event

$$C_{100} = \frac{(89.74 \times 1.0) + (10.68 \times 1.0) + (15.04 \times 1.0) + (86.72 \times 0.2 \times 1.25)}{202.18}$$

$$C_{100} = \frac{137.14}{202.18}$$

$$C_{100} = 0.678$$

$$\text{Say "C}_{100}\text{"} = 0.68$$

$$Q_{100} = 2.78 (0.68)(178.6)(0.0202)$$

$$Q_{100} = 6.82 \text{ L/s}$$

Estimated uncontrolled flow to the Baseline Road road right-of-way: the five (5)-Year post-development flow is 3.45 L/s and 6.82 L/s for the 100-Year event.

ii. Uncontrolled Drainage Area to Lexington Street (R.O.W.) – Node #5

Roof Area	= 26.24 m ²
Interlock/Concrete Area	= 80.59 m ²
Grass Area	= 24.23 m ²
Riverstone Area	= 8.31 m ²

$$A_{\text{total (to Lexington Street)}} = 139.37 \text{ m}^2$$

5-Year Event

$$C_5 = \frac{(26.24 \times 0.9) + (80.59 \times 0.9) + (8.31 \times 0.8) + (24.23 \times 0.2)}{139.37}$$

$$C_5 = \frac{107.641}{139.37}$$

$$C_5 = 0.772$$

Say "C₅" = 0.77

$$Q_5 = 2.78 (0.77)(104.20)(0.0139)$$

$$Q_5 = 3.10 \text{ L/s}$$

100-Year Event

$$C_{100} = \frac{(26.24 \times 1.0) + (80.59 \times 1.0) + (8.31 \times 1.0) + (24.23 \times 0.2 \times 1.25)}{139.37}$$

$$C_{100} = \frac{121.198}{139.37}$$

$$C_{100} = 0.8696$$

Say "C₁₀₀" = 0.87

$$Q_{100} = 2.78 (0.87)(178.6)(0.0139)$$

$$Q_{100} = 6.0 \text{ L/s}$$

Estimated uncontrolled flow to the Lexington Street road right-of-way: the five (5)-Year post-development flow is 3.10 L/s and 6.0 L/s for the 100-Year event.

Table A : Summary of POST-DEVELOPMENT Uncontrolled Flow Estimation

DESCRIPTION	AREA (ha.)	5-YEAR FLOW (L/s)	100-YEAR FLOW (L/s)
Total Uncontrolled Area	0.03415	6.63	12.90
Area draining to Baseline Road (ROW)	0.0202	3.45	6.82
Area draining to Lexington Street (ROW)	0.0139	3.10	6.0

Therefore for the site in its entirety, under post-development condition, the 5-Year uncontrolled flow off-site is estimated at 6.63 L/s and the 100-Year uncontrolled flow is 12.90 L/s.

For this site, because 341.55 square meters of the site area is drained uncontrolled off-site, the net allowable discharge for this site into the existing storm sewer system using the five (5)-Year storm event criteria at $C_{pre} = 0.40$ is calculated as follows: $Q = \{2.78 (0.40) (104.20) (0.0692) - [2.78 (0.76) (178.6) (0.03416)]\} = 8.02 \text{ L/s} - 12.90 \text{ L/s} = -4.88 \text{ L/s}$. Therefore, according to this approach, the maximum calculated allowable flow rate off-site is 8.02 L/s and the net allowable controlled flow rate off-site is -4.88 L/s which is not practical.

Stormwater Management Analysis

Based on the above calculation from site information provided and given the small area size of the lot under consideration (691.58 m²) therefore to limit the maximum allowable flow off-site to 8.02 L/s the City of Ottawa Engineering Department recognized that this is not achievable.

For this proposed development, the building flat rooftop will be used to provide Stormwater Management (SWM) attenuation for this site. Three (3) controlled roof drains are proposed to regulate flow off-site for on-site SWM measures to be incorporated with this proposed development.

The roof drain flow rate proposed is set at 0.87 L/s (13.75 U.S. gal/min.) at a head of 125mm during the 5-Year storm event for Roof Drain #1, Roof Drain #2 and Roof Drain #3. The roof drain flow rate proposed for the 100-Year storm event is set at 0.95 L/s (15.0 U.S. gal/min.) for Roof Drain #1, Roof Drain #2 and Roof Drain #3. Therefore, during the 100-Year storm event, the total controlled roof drain maximum flow off-site is 2.85 L/s (45.0 U.S. gal/min.).

Thus for this site, the 5-Year maximum post development flow rate draining off-site is the uncontrolled flow from the lot plus controlled rooftop flow which equals to 9.24 L/s (6.63 L/s + 2.61 L/s) which is 1.22 L/s above the 8.02 L/s set by the SWM criteria for this site. During the 100-Year event, the maximum post development flow rate off-site is estimated at 15.75 L/s (12.90 L/s + 2.85 L/s) which exceeds the allowable site flow of 8.02 L/s by 7.73 L/s.

Therefore for this proposed development site, the total maximum allowable five (5)-Year release site of 8.02 L/s will be slightly exceeded by 1.22 L/s since the estimated flow is 9.24 L/s. For storm events up to and including 100-Year event, the total maximum allowable release rate of 8.02 L/s will be exceeded by 7.73 L/s (estimated at 15.75 L/s) where the flow exceedance is 7.73 L/s for this site.

However, in comparing the pre-development flow of the current site conditions to the post-development flow, the SWM regulated flow plus uncontrolled flow from the proposed site under the post-development conditions at the 5-Year event = 9.24 L/s and the 100-Year event = 15.75 L/s where both of the post-development flow events are approximately equal to the current pre-development flow estimate for the site at 5-Year $_{pre} = 8.02 \text{ L/s}$ and 100-Year $_{pre} = 16.15 \text{ L/s}$. Therefore with this proposed development, stormwater flow is approximately the same as that of the existing condition for the 5-Year event and is improved at the 100-Year event level.

To the controlled drainage area (flat rooftop of proposed building) the post-development inflow rate during the five (5)-Year and 100-Year storms for the (3) three flat rooftop area can be calculated as follows:

Design Discharge Computation

Flat Rooftop Areas

To Calculate Roof Storage Requirements

The proposed flat roof of the apartment building on this property will incorporate three (3) roof drains to control flow off-site for this development property. The roof drain flow rate proposed is at 0.95 L/s (15.0 U.S. gal./min.) for Roof Drain #1 to Roof Drain #3 inclusive. The specified roof drain is the Watts “Adjustable Accutrol Weir” (Model No. RD-100-A-ADJ) with each weir opening in the 1/4 exposed position, which will allow a maximum flow of 0.95 L/s under a maximum head of 150 mm water above the drain for Roof Drain #1, Roof Drain #2 and Roof Drain #3 inclusive. The weir opening in the 1/4 exposed position which will allow a flow of 0.95 L/s (15.0 U.S. gal./min.) under a head of 150 mm water above the drain. See Appendix C for roof drain details. Therefore, the stormwater flow that can be controlled from this building flat rooftop and outletted off-site is $(3 \times 0.95 \text{ L/s}) = 2.85 \text{ L/s}$. Refer to the Proposed Stormwater Management Plan (Dwg. No. 824-74 SWM-1) for roof drain details.

C = 0.9 will be used for sizing roof storage volume in this case.

Inflow rate (Q_A) = 2.78 CIA

Where C = 0.9
A = Surface are of roof
I = (mm/hr)

For Roof Area No. 1 (NODE #1)

5-Year Event

$C_5 = 0.90$

$A = 135.12 \text{ m}^2$

I = mm/hr

$Q_{A1} = 2.78 (0.90) (0.0135 \text{ ha.}) I$

= 0.0338 I

100-Year Event

$C_{100} = 1.0$

$A = 135.12 \text{ m}^2$

I = mm/hr

$Q_{A1} = 2.78 (1.0) (0.0135 \text{ ha.}) I$

= 0.0375 I

For Roof Area No. 2 (NODE #2)

5-Year Event

$$C_5 = 0.90$$

$$A = 106.20 \text{ m}^2$$

$$I = \text{mm/hr}$$

$$Q_{A2} = 2.78 (0.90) (0.0106 \text{ ha.}) I$$

$$= 0.0265 I$$

100-Year Event

$$C_{100} = 1.0$$

$$A = 106.20 \text{ m}^2$$

$$I = \text{mm/hr}$$

$$Q_{A2} = 2.78 (1.0) (0.0106 \text{ ha.}) I$$

$$= 0.0295 I$$

For Roof Area No. 3 (NODE #3)

5-Year Event

$$C_5 = 0.90$$

$$A = 108.71 \text{ m}^2$$

$$I = \text{mm/hr}$$

$$Q_{A3} = 2.78 (0.90) (0.0109 \text{ ha.}) I$$

$$= 0.0273 I$$

100-Year Event

$$C_{100} = 1.0$$

$$A = 108.71 \text{ m}^2$$

$$I = \text{mm/hr}$$

$$Q_{A3} = 2.78 (1.0) (0.0109 \text{ ha.}) I$$

$$= 0.0303 I$$

The summary results of the calculated inflow and the storage volume of the site and the building's flat rooftop to store the 5-Year and 100-Year storm events are shown on the **Tables 1 to 3** inclusive and the **Tables 4 to 6** inclusive.

Table 7 summarizes the post-development design flows from the building roof top area as well as the type of roof drains, the maximum anticipated ponding depths, storage volumes required, and storage volumes provided for the five (5)-Year and 100-Year design events.

Table 7: Design Flow and Roof Drain Table

Roof Area ID & Drainage Area (ha)	Number of Roof Drains	Watts Roof Drain Model ID (Weir Opening)	Controlled Flow per Drain (L/s)		Approximate Ponding Depth Above Drains (m)		Storage Volume Required (m ³)		Max. Storage Available (m ³)
			5 YR	100 YR	5 YR	100 YR	5 YR	100 YR	
RD-1 (0.0135 ha)	1	RD-100-A-ADJ (1/4 OPENING EXPOSED)	0.87	0.95	0.125	0.15	1.91	4.52	6.12
RD-2 (0.0106 ha)	1	RD-100-A-ADJ (1/4 OPENING EXPOSED)	0.87	0.95	0.125	0.15	1.29	3.18	3.36
RD-3 (0.0109 ha)	1	RD-100-A-ADJ (1/4 OPENING EXPOSED)	0.87	0.95	0.125	0.15	1.36	3.31	4.91
Total Roof (0.035 ha)	3	-	2.61	2.85	-	-	4.56	11.01	14.39

Erosion and Sediment Control

The contractor shall implement Best Management Practices to provide for protection of the receiving storm sewer during construction activities. These practices are required to ensure no sediment and/or associated pollutants are released to the receiving watercourse. These practices include installation of a “siltsack” catch basin sediment control device or equal in catch basins as recommended by manufacturer on-site and off-site within the Baseline Road and Lexington Street road right-of-way adjacent to this property. Siltsack shall be inspected every 2 to 3 weeks and after every major storm. The deposits will be disposed of as per the requirements of the contract. See Dwg. No. 824-74 ESC-1 for details.

Conclusion

At this proposed residential site and to develop this lot to house a 18 unit apartment building on a 0.0692 ha. parcel of land, the estimated allowable flow off-site is calculated at 8.02 L/s based on City of Ottawa Drainage and Stormwater Management (SWM) criteria of 5-Year pre-development flow at $C_{pre} = 0.40$. For on-site SWM attenuation, the flat roof top of the proposed apartment building will be utilized and (3) controlled roof drains are incorporated each with a controlled maximum release rate of 0.95 L/s (15.0 U.S. gal/min.) under a maximum head of 150 mm. The controlled flow from this site at the 5-Year event totals to 2.61 L/s and 2.85 L/s for the 100-Year event for the post development condition. The uncontrolled 5-Year post development flow from the remainder of the site is estimated at 6.63 L/s and 12.90 L/s for the 100-year event respectively.

During the five (5)-year storm event for the flat rooftop storage, the ponding depth of rooftop area 1, 2 and 3 is estimated at 125 mm at the drain and 0mm at the roof perimeter, assuming a 1.6% minimum roof pitch to the drain. The rooftop storage available at Roof Area 1 is 3.30 m³, at Roof Area 2 is 2.06 m³ and the rooftop storage available at Roof Area 3 is 2.73 m³, for a total of 8.09 m³, which is greater than the required volume of 4.57 m³.

During the 100-year storm event for the flat rooftop storage, the ponding depth of Roof Area 1, 2 and 3 is estimated at 150 mm at the drain and 0mm at the roof perimeter, assuming a 1.6% minimum roof pitch to the drain. The rooftop storage available at Roof Area 1 is 6.12 m³, at Roof Area 2 is 3.36 m³ and the rooftop storage available at Roof Area 3 is 4.91 m³, for a total of 14.39 m³, which is greater than the required volume of 11.01 m³.

Therefore, by means of flat building rooftop storage and grading the site to the proposed grades as shown on the Proposed Grading and Servicing Plan and Proposed Rooftop Stormwater Management Plan Dwg. 824-74 G-1 and 824-74 SWM-1 respectively, the desirable five (5)-Year storm and 100-Year storm event detention volume of 8.09 m³ and 14.39 m³ respectively will be available on site. Refer to Appendix D for detailed calculations of available storage volumes.

Thus for this development site, the 5-Year maximum post development flow draining off-site is the controlled roof top flow plus the uncontrolled flow from the remainder of the site totals to 9.24 L/s (2.61 L/s + 6.63 L/s) which is slightly above the allowable 8.02 L/s. For storm events up to and including 100-Year, the estimated maximum post development flow draining off-site is 15.75 L/s (2.85 L/s + 12.90 L/s) which exceeds the site allowable of 8.02 L/s by 7.73 L/s for this site.

In comparing the pre-development flow of the current site conditions to the post development flow, the SWM regulated flow plus uncontrolled flow from the proposed site under the post development conditions at the 5-Year event = 9.24 L/s and the 100 year event = 15.75 L/s where both of the post development flow events are approximately equal to the current pre-development flow estimate for the site at 5-Year_{pre} = 8.02 L/s and 100-Year_{pre} = 16.15 L/s. Therefore with this proposed development, stormwater flow is slightly above that of the existing condition for the 5-Year event and is improved at the 100-Year event under the proposed post-development conditions.

Flow estimation of the uncontrolled area draining to the Lexington Street and Baseline Road road right-of-way for the post-development conditions are summarized and found in Table A of this report. The 5-Year flow draining out to the Lexington Street (ROW) is estimated at 3.10 L/s and 6.0 L/s for 100-Year event. Approximately 44.0% of the pre-development existing site is currently draining out to the Lexington Street road right-of-way at the 5Yr_{pre} event flow is 0.44 × 8.02 L/s = 3.53 L/s and the 100Yr_{pre} event flow is 0.44 × 16.15 L/s = 7.11 L/s . We observed that the post-development flow to the Lexington Street (ROW) is improved from that of the existing site conditions.

The building weeping tile drainage will outlet via its separate 150mm diameter PVC storm lateral. The roof drains will be outletted also via a separate 150mm PVC storm lateral from the apartment building which “wye” into the proposed 150mm dia. weeping tile storm lateral, whereupon both laterals are outletting to the existing Baseline Road 1500mm diameter storm sewer with only one (1) connection. The City of Ottawa recommends that pressurized drain pipe material be used in the building for the roof drain leader pipe in the event of surcharging on the City storm sewer system. Refer to the proposed site grading and servicing plan Dwg. 824-74 G-1 for details.

PREPARED BY T.L. MAK ENGINEERING CONSULTANTS LTD.



TONY L. MAK, P.ENG



PROPOSED 222 BASELINE ROAD RESIDENTIAL APARTMENT BUILDING DEVELOPMENT SITE

TABLE 1
FIVE (5)-YEAR EVENT

REQUIRED BUILDING ROOF AREA 1 STORAGE VOLUME

ROOF DRAIN No. 1

t_c TIME (minutes)	I 5-YEAR (mm/hr)	Q ACTUAL (L/s)	Q ALLOW (L/s)	Q STORED (L/s)	VOLUME STORED (m³)
5	141.20	4.77	0.79	3.98	1.19
10	104.20	3.52	0.79	2.73	1.64
15	83.50	2.82	0.79	2.03	1.83
20	70.30	2.38	0.79	1.59	<u>1.91</u>
25	60.90	2.06	0.79	1.27	1.905
30	53.93	1.82	0.79	1.03	1.85
35	48.50	1.64	0.79	0.85	1.79

Therefore, the required rooftop storage volume is 1.91 m³.

SITE DATA

Roof Area = 135.12 m² = 0.0135 ha.

PROPOSED 222 BASELINE ROAD RESIDENTIAL APARTMENT BUILDING DEVELOPMENT SITE

TABLE 2
FIVE (5)-YEAR EVENT

REQUIRED BUILDING ROOF AREA 2 STORAGE VOLUME

ROOF DRAIN No. 2

t_c TIME (minutes)	I 5-YEAR (mm/hr)	Q ACTUAL (L/s)	Q ALLOW (L/s)	Q STORED (L/s)	VOLUME STORED (m³)
5	141.20	3.74	0.79	2.95	0.89
10	104.20	2.76	0.79	1.97	1.18
15	83.50	2.21	0.79	1.42	1.28
20	70.30	1.86	0.79	1.07	<u>1.29</u>
25	60.90	1.61	0.79	0.82	1.23
30	53.93	1.43	0.79	0.64	1.15
35	48.50	1.29	0.79	0.50	1.05

Therefore, the required rooftop storage volume is 1.29 m³.

SITE DATA

Roof Area = 106.20 m² = 0.0106 ha.

PROPOSED 222 BASELINE ROAD RESIDENTIAL APARTMENT BUILDING DEVELOPMENT SITE

TABLE 3
FIVE (5)-YEAR EVENT

REQUIRED BUILDING ROOF AREA 3 STORAGE VOLUME

ROOF DRAIN No. 3

t_c TIME (minutes)	I 5-YEAR (mm/hr)	Q ACTUAL (L/s)	Q ALLOW (L/s)	Q STORED (L/s)	VOLUME STORED (m ³)
5	141.20	3.86	0.79	3.07	0.92
10	104.20	2.85	0.79	2.06	1.24
15	83.50	2.28	0.79	1.49	1.34
20	70.30	1.92	0.79	1.13	<u>1.36</u>
25	60.90	1.66	0.79	0.87	1.31
30	53.93	1.47	0.79	0.68	1.22
35	48.50	1.32	0.79	0.53	1.11

Therefore, the required rooftop storage volume is 1.36 m³.

SITE DATA

Roof Area = 108.71 m² = 0.0109 ha.

PROPOSED 222 BASELINE ROAD RESIDENTIAL APARTMENT BUILDING DEVELOPMENT SITE

TABLE 4

100-YEAR EVENT

REQUIRED BUILDING ROOF AREA 1 STORAGE VOLUME

ROOF DRAIN No. 1

t_c TIME (minutes)	I 100-YEAR (mm/hr)	Q ACTUAL (L/s)	Q ALLOW (L/s)	Q STORED (L/s)	VOLUME STORED (m³)
10	178.6	6.698	0.95	5.748	3.45
15	142.9	5.359	0.95	4.409	3.97
20	120.0	4.50	0.95	3.550	4.26
25	103.9	3.90	0.95	2.950	4.43
30	91.9	3.446	0.95	2.496	4.49
35	82.6	3.10	0.95	2.150	<u>4.52</u>
40	75.1	2.816	0.95	1.866	4.48
45	69.1	2.59	0.95	1.641	4.43
50	63.9	2.396	0.95	1.446	4.34

Therefore, the required rooftop storage volume is 4.52 m³.

SITE DATA

Roof Area = 135.12 m² = 0.0135 ha.

PROPOSED 222 BASELINE ROAD RESIDENTIAL APARTMENT BUILDING DEVELOPMENT SITE

TABLE 5

100-YEAR EVENT

REQUIRED BUILDING ROOF AREA 2 STORAGE VOLUME

ROOF DRAIN No. 2

t_c TIME (minutes)	I 100-YEAR (mm/hr)	Q ACTUAL (L/s)	Q ALLOW (L/s)	Q STORED (L/s)	VOLUME STORED (m³)
10	178.6	5.269	0.95	4.319	2.59
15	142.9	4.216	0.95	3.266	2.94
20	120.0	3.540	0.95	2.590	3.11
25	103.9	3.065	0.95	2.115	<u>3.173</u>
30	91.9	2.711	0.95	1.761	3.170
35	82.6	2.437	0.95	1.487	3.12
40	75.1	2.216	0.95	1.266	3.04
45	69.1	2.039	0.95	1.089	2.94

Therefore, the required rooftop storage volume is 3.18 m³.

SITE DATA

Roof Area = 106.20 m² = 0.0106 ha.

PROPOSED 222 BASELINE ROAD RESIDENTIAL APARTMENT BUILDING DEVELOPMENT SITE

TABLE 6

100-YEAR EVENT

REQUIRED BUILDING ROOF AREA 3 STORAGE VOLUME

ROOF DRAIN No. 3

t_c TIME (minutes)	I 100-YEAR (mm/hr)	Q ACTUAL (L/s)	Q ALLOW (L/s)	Q STORED (L/s)	VOLUME STORED (m³)
10	178.6	5.412	0.95	4.46	2.68
15	142.9	4.330	0.95	3.38	3.04
20	120.0	3.636	0.95	2.69	3.23
25	103.9	3.148	0.95	2.20	3.30
30	91.9	2.785	0.95	1.84	<u>3.31</u>
35	82.6	2.503	0.95	1.55	3.26
40	75.1	2.276	0.95	1.33	3.19
45	69.1	2.094	0.95	1.15	3.11

Therefore, the required rooftop storage volume is 3.31 m³.

SITE DATA

Roof Area = 108.71 m² = 0.0109 ha.

PROPOSED RESIDENTIAL APARTMENT BUILDING

LOT DEVELOPMENT SITE

222 BASELINE ROAD

PART OF LOT 72

R-PLAN 526

CITY OF OTTAWA

APPENDIX A

SITE PLAN

AND

STORM DRAINAGE AREA PLAN

FIGURE 1

PROPOSED 222 BASELINE ROAD SITE DEVELOPMENT DRAINAGE AREA PLAN

N.T.S.

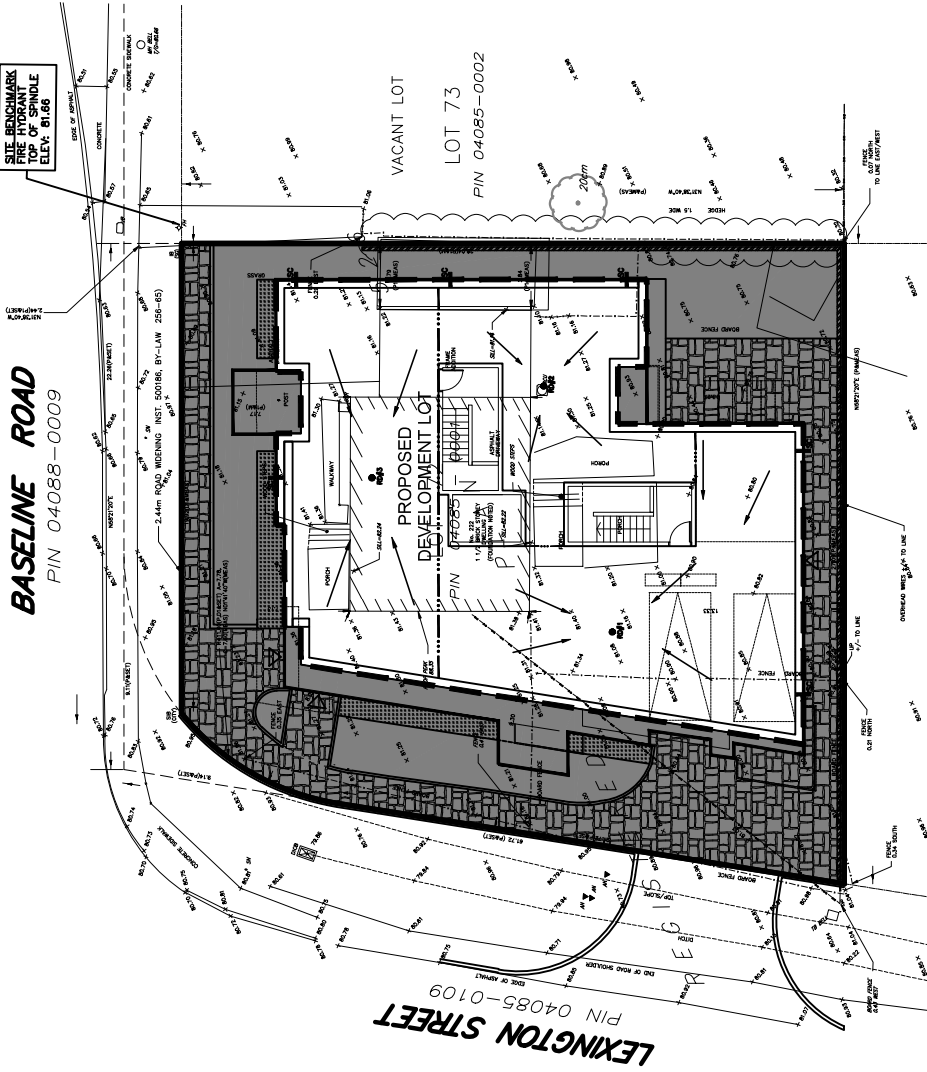

LEGEND

- LIMIT OF CONTROLLED STORM
 DRAINAGE AREA = 350.03 SQ. M
 - UNCONTROLLED STORM
 DRAINAGE AREA = 341.55 SQ. M
- TOTAL AREA = 691.58 SQ. M

POST-DEVELOPMENT SITE
AVERAGE "C" = 0.78

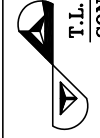

T.L. MAK ENGINEERING CONSULTANTS LTD.
CONSULTING ENGINEERS

PROJECT No. 824-74
DATE SEPTEMBER 2025
DRAWING No. FIGURE 1

PROPOSED RESIDENTIAL APARTMENT BUILDING

LOT DEVELOPMENT SITE

222 BASELINE ROAD

PART OF LOT 72

R-PLAN 526

CITY OF OTTAWA

APPENDIX B

SITE PRE-DEVELOPMENT CONDITION

GOOGLE IMAGE 2024,

AERIAL PHOTOGRAPHY 2022 (GEOOTTAWA)

AND

TOPOGRAPHICAL SURVEY PLAN (BY STANTEC GEOMATICS LTD.)







PROPOSED RESIDENTIAL APARTMENT BUILDING

LOT DEVELOPMENT SITE

222 BASELINE ROAD

PART OF LOT 72

R-PLAN 526

CITY OF OTTAWA

APPENDIX C

PROPOSED ROOF DRAIN

DETAILS



Adjustable Accutrol Weir

Tag: _____

Adjustable Flow Control for Roof Drains

ADJUSTABLE ACCUTROL (for Large Sump Roof Drains only)

For more flexibility in controlling flow with heads deeper than 2", Watts Drainage offers the Adjustable Accutrol. The Adjustable Accutrol Weir is designed with a single parabolic opening that can be covered to restrict flow above 2" of head to less than 5 gpm per inch, up to 6" of head. To adjust the flow rate for depths over 2" of head, set the slot in the adjustable upper cone according to the flow rate required. Refer to Table 1 below.
 Note: Flow rates are directly proportional to the amount of weir opening that is exposed.

EXAMPLE:

For example, if the adjustable upper cone is set to cover 1/2 of the weir opening, flow rates above 2" of head will be restricted to 2-1/2 gpm per inch of head.

Therefore, at 3" of head, the flow rate through the Accutrol Weir that has 1/2 the slot exposed will be:
 [5 gpm (per inch of head) x 2 inches of head] + 2-1/2 gpm (for the third inch of head) = 12-1/2 gpm.

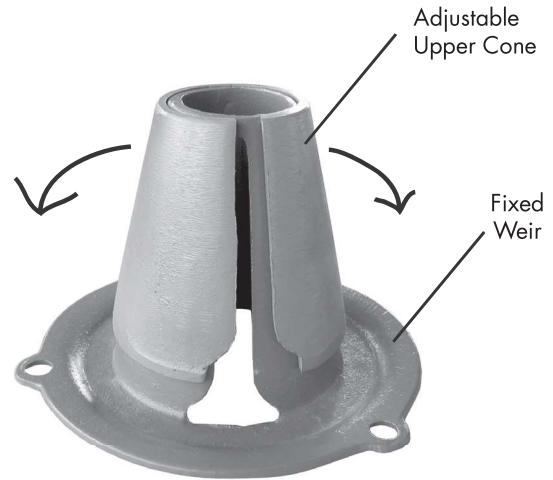
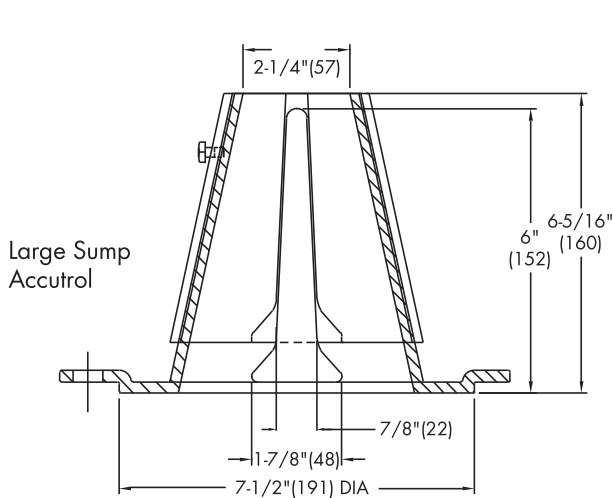

1/2 Weir Opening Exposed Shown Above

TABLE 1. Adjustable Accutrol Flow Rate Settings

Weir Opening Exposed	1"	2"	3"	4"	5"	6"
	Flow Rate (gallons per minute)					
Fully Exposed	5	10	15	20	25	30
3/4	5	10	13.75	17.5	21.25	25
1/2	5	10	12.5	15	17.5	20
1/4	5	10	11.25	12.5	13.75	15
Closed	5	5	5	5	5	5

Job Name _____
 Job Location _____
 Engineer _____

Contractor _____
 Contractor's P.O. No. _____
 Representative _____

Watts product specifications in U.S. customary units and metric are approximate and are provided for reference only. For precise measurements, please contact Watts Technical Service. Watts reserves the right to change or modify product design, construction, specifications, or materials without prior notice and without incurring any obligation to make such changes and modifications on Watts products previously or subsequently sold.

USA: Tel: (800) 338-2581 • Fax: (828) 248-3929 • Watts.com
 Canada: Tel: (905) 332-4090 • Fax: (905) 332-7068 • Watts.ca
 Latin America: Tel: (52) 81-1001-8600 • Fax: (52) 81-8000-7091 • Watts.com



A Watts Water Technologies Company

PROPOSED RESIDENTIAL APARTMENT BUILDING

LOT DEVELOPMENT SITE

222 BASELINE ROAD

PART OF LOT 72

R-PLAN 526

CITY OF OTTAWA

APPENDIX D

DETAILED CALCULATIONS

FOR FIVE (5)-YEAR AND 100-YEAR

AVAILABLE STORAGE VOLUME

AVAILABLE STORAGE VOLUME CALCULATIONS

Five (5)-Year Event

Roof Storage at Flat Roof Building

The flat Roof Area 1, Roof Area 2 and Roof Area 3 will be used for stormwater detention. Each roof area will be drained by a controlled drain designed for a release rate of 13.75 U.S. gal/min. or 0.87 L/s under a head of 125 mm. Refer to Dwg. No. 824-74 SWM-1 for roof drain details.

Roof Storage Area No. 1 (NODE No. 1)

Available flat roof area for storage = 123.56 m², C = 0.9 @ roof slope of 1.6% (min.) or 125 mm of water height above the roof drain. Therefore, the available roof area will store a volume shown below using the reservoir volume equation.

$$V = \frac{(0.125 \text{ m})[77.50 + 4 (20.26) + 0]}{6}$$

$$V = \frac{(0.125 \text{ m})(158.54)}{6}$$

$$V = 3.30 \text{ m}^3$$

The available Roof Area 1 storage volume of 3.30 m³ > required five (5)-Year storage volume of 1.91 m³ from Table 1.

Roof Storage Area No. 2 (NODE No. 2)

Available flat roof area for storage = 62.08 m², C = 0.9 @ roof slope of 1.8% (min.) or 125 mm of water height above the roof drain. Therefore, the available roof area will store a volume shown below using the reservoir volume equation.

$$V = \frac{(0.125 \text{ m})[45.85 + 4 (13.23) + 0]}{6}$$

$$V = \frac{(0.125 \text{ m})(98.77)}{6}$$

$$V = 2.06 \text{ m}^3$$

The available Roof Area 2 storage volume of 2.06 m³ > required five (5)-Year storage volume of 1.29 m³ from Table 2.

Roof Storage Area No. 3 (NODE No. 3)

Available flat roof area for storage = 96.65 m², C = 0.9 @ roof slope of 1.7% (min.) or 125 mm of water height above the roof drain. Therefore, the available roof area will store a volume shown below using the reservoir volume equation.

$$V = \frac{(0.125 \text{ m})[65.76 + 4 (16.31) + 0]}{6}$$

$$V = \frac{(0.125 \text{ m})(131.0)}{6}$$

$$V = 2.73 \text{ m}^3$$

The available Roof Area 3 storage volume of 2.73 m³ > required five (5)-Year storage volume of 1.36 m³ from Table 3.

Therefore, the ponding depth at the proposed Roof Drain No. 1, Roof Drain No. 2 and Roof Drain No. 3 location is approximately 0.125 m (125 mm) and the five (5)-Year level is estimated not to reach the roof perimeter of the building.

Hence, Roof Area 1, Roof Area 2 and Roof Area 3 of the proposed residential building flat rooftop storage are adequate to store the minimum required five (5)-Year storm event volume of 4.57 m³ given it can store up to 8.09 m³.

AVAILABLE STORAGE VOLUME CALCULATIONS

100-Year Event

Roof Storage at Flat Roof Building

The flat Roof Area 1, Roof Area 2 and Roof Area 3 will be used for stormwater detention. Each roof area will be drained by a controlled drain designed for a release rate of 15.0 U.S. gal/min. or 0.95 L/s under a head of 150 mm. Refer to Dwg. No. 824-74 SWM-1 for roof drain details.

Roof Storage Area No. 1 (NODE No. 1)

Available flat roof area for storage = 123.56 m², C = 0.9 @ roof slope of 1.6% (min.) or 150 mm of water height above the roof drain. Therefore, the available roof area will store a volume shown below using the reservoir volume equation.

$$V = \frac{(0.15 \text{ m})[123.56 + 4 (30.28) + 0]}{6}$$

$$V = \frac{(0.15 \text{ m})(244.68)}{6}$$

$$V = 6.12 \text{ m}^3$$

The available Roof Area 1 storage volume of 6.12 m³ > required 100-Year storage volume of 4.52 m³ from Table 4.

Roof Storage Area No. 2 (NODE No. 2)

Available flat roof area for storage = 62.08 m², C = 0.9 @ roof slope of 1.8% (min.) or 150 mm of water height above the roof drain. Therefore, the available roof area will store a volume shown below using the reservoir volume equation.

$$V = \frac{(0.15 \text{ m})[62.08 + 4 (18.11) + 0]}{6}$$

$$V = \frac{(0.15 \text{ m})(134.52)}{6}$$

$$V = 3.36 \text{ m}^3$$

The available Roof Area 2 storage volume of 3.36 m³ > required 100-Year storage volume of 3.18 m³ from Table 5.

Roof Storage Area No. 3 (NODE No. 3)

Available flat roof area for storage = 96.65 m², C = 0.9 @ roof slope of 1.7% (min.) or 150 mm of water height above the roof drain. Therefore, the available roof area will store a volume shown below using the reservoir volume equation.

$$V = \frac{(0.15 \text{ m})[96.65 + 4 (24.94) + 0]}{6}$$

$$V = \frac{(0.15 \text{ m})(196.41)}{6}$$

$$V = 4.91 \text{ m}^3$$

The available Roof Area 3 storage volume of 4.91 m³ > required two (2)-Year storage volume of 3.31 m³ from Table 6.

Hence, Roof Area 1, Roof Area 2 and Roof Area 3 of the proposed residential building flat rooftop storage is adequate to store the minimum required 100-Year storm event volume of 11.01 m³ given it can store up to 14.39 m³.

Therefore, the ponding depth at the Roof Drain 1, Roof Drain 2 and Roof Drain 3 location is approximately 0.15 m (150 mm), and at the perimeter of the flat roof area is 0 mm above the roof perimeter surface. Accordingly, it is recommended that six (6) building perimeter roof scuppers as shown on Dwg. No. 824-74 G-1 and Dwg. No. 824-74 SWM-1 and the architect's roof plan be installed at the perimeter height of the rooftop for emergency overflow purposes in case of blockage from debris build up at the roof drain.