

# D.B. Gray Engineering Inc.

*Stormwater Management - Grading & Drainage - Storm & Sanitary Sewers - Watermains*

700 Long Point Circle  
Ottawa, Ontario K1T 4E9

613-425-8044  
d.gray@dbgrayengineering.com

## SITE SERVICING STUDY & STORMWATER MANAGEMENT REPORT

151-159 WESCAR LANE  
OTTAWA, ONTARIO

REPORT NO. 23024

AUGUST 31, 2023  
REVISED DECEMBER 13, 2023  
REVISED AUGUST 22, 2024  
REVISED FEBRUARY 7, 2025

# **CONTENTS**

- 1.0 INTRODUCTION**
- 2.0 WATER SERVICING**
  - 2.1 WATER SUPPLY FOR FIREFIGHTING
  - 2.2 DOMESTIC WATER SUPPLY
- 2.0 SANITARY SERVICING**
- 4.0 STORMWATER MANAGEMENT**
  - 4.1 QUALITY CONTROL
  - 4.2 QUANTITY CONTROL
  - 4.3 STORM SERVICING
- 5.0 CONCLUSIONS**

# **LIST OF APPENDICES**

- A WATER SERVICING
- B SANITARY SERVICING
- C STORMWATER MANAGEMENT & STORM SEWER SYSTEM
- D CITY OF OTTAWA PRE-CONSULTATION MEETING MINUTES & SERVICING STUDY CHECKLIST

## 1.0 INTRODUCTION

This Servicing Study & Stormwater Management Report is a description of the servicing for two office / warehouse buildings and addresses the stormwater management requirements of 4.63 hectares of land located at 151-159 Wescar Lane, in Ottawa. The property is L-shaped and also has frontage on Cavanmore Road. The property is currently vacant.

This report forms part of the servicing and stormwater management design for the proposed development. Also refer to drawings C-1 to C-16 prepared by D. B. Gray Engineering Inc.

## 2.0 WATER SERVICING

### 2.1 WATER SUPPLY FOR FIREFIGHTING

The proposed Phase 1 building is actually three buildings divided by two 2-hour firewalls comprising of a 2-storey office building (Building 'A' – total floor area of 763 m<sup>2</sup>), and two 1-storey warehouse buildings, each with a mezzanine (Building 'B' – total 1,081 m<sup>2</sup> and Building 'C' – total 1,497 m<sup>2</sup>). The proposed Phase 2 building is a 1-storey office / warehouse building with a mezzanine (total 1,128 m<sup>2</sup>).

Using the Ontario Building Code (OBC) method, of the four proposed buildings, Phase 1 Building 'C' is calculated to have the greatest required volume of 267,339 L, which calculates to be about a 42-minute water supply at 6,300 L/min (as per OBC A-3.2.5.7. Table 2), which is greater than the 30-minute minimum required by OBC. Refer to calculations in Appendix A.

These calculations were submitted to the Ottawa Fire Services (OFS) to determine if the storage credit of 57,000 L is available. (It is available if the site meets the Fire Underwriters Survey (FUS) requirements for superior tanker shuttle; specifically the site must be within 5 km of a fire station and 2.5 km of an OFS approved water source.) As stated in an email, dated July 11, 2024, from Allan Evans (Fire Protection Engineer, Ottawa Fire Services): *“Unfortunately this site does not meet the FUS requirements (nearest fire station is 7.4km and the nearest water source is 2.9km) so no reduction of the Q value will be permitted.*

Six 45,000 L (10,000 gallon) tanks are proposed for a total of 270,000 L. This exceeds the 267,339 L that is required. Two fire tanks (one at each end of the row of tanks) will be equipped with draw pipes (the others with access opening with vents), and two onsite fire hydrants are proposed.

As was discussed with the OFS intent of the fire protection design is to have a remote fire hydrant located next to a fire tank with a chute. In the event of a fire the OFS would draw water from the fire tank via the chute using a pumper truck. The pumper truck could also be connected to the remote hydrant and pump via 150 mm diameter private watermains to two other onsite fire hydrants (located as per the discussions with the OFS). None of the fire hydrants are directly connected to the fire tanks. All the fire hydrants are of the type that connect to a municipal watermain (i.e. the fire hydrants are not 'dry hydrants for drafting from storage reservoirs'), and the watermains will be constructed to City standards including with a minimum 2.4m cover; therefore, the system does not need to be winterized.

As discussed with the OFS, a pumper truck is capable of drawing 4,500 L/min, typically at 70 psi (but is capable of over 100 psi). A model was created using EPANET software to analyze the hydraulics of the private watermain, 140 m in length, from the remote fire hydrant (FH-2) to the furthest onsite fire hydrant (FH-1). Based 4,500 L/min at 70 psi at FH-2, the pressure at the fire hose connection at FH-1 is calculated to be 24.2 psi. (A model was also created using EPANET software to analyze the 78 m watermain, from FH-2 to FH-3, and based 4,500 L/min at 70 psi the pressure at the FH-3 hose connection is calculated to be 29.7 psi. Since the pressures are at least 138 kPa (20 psi), the private watermains are adequately sized.

## 2.2 DOMESTIC WATER SUPPLY

An existing drilled well, constructed approximately 4 m south of the southeast corner of proposed Phase 1 Building 'A', will provide the domestic water supply.

As stated in the Hydrogeology and Terrain Study, prepared by Kollaard Associates (File No: 230403, dated November 13, 2023):

*"The daily sewage design flow is equal to a maximum daily demand for the site. The site is to be developed in two phases ... the corresponding sewage design flows as provided by the sewage design consultant (DB Gray Engineering) [is] 8,615 L/day". Since sewage system design is based on the maximum expected daily use, it is equivalent to the Maximum Daily Demand (MDD). The MDD is based on an eight hour operation schedule (i.e. full day occurs over an eight hour period and not over 24 hours)."*

*"City of Ottawa calculates the Maximum Hour Demand (MHD) for a commercial or industrial demand to be 1.8 x MDD."*

*"MDD = 8,615 litres / day x 1 day / 8 hours x 1 hour / 60 minutes  
= 18 litres / minute"*

*"MHD = 1.8 x MDD  
= 1.8 x 18 litres / minute  
= 32.3 litres / minute"*

*"The City of Ottawa predicated water usage for MDD and MHD of 18 L/min and 32.3 L/min, respectively, are used."*

*"The Maximum Hourly Demand (MHD) for the site based on its proposed use is expected to be about ~32.5 litres/minute, compared to the pumping test rate which was 38 litres/minute. This indicates that the pumping rate used for the test was appropriate as the peak water demand rate was met for the test. The MDD is 8,615 L/day. The test was carried out for 6 hours at the above noted rate and some ~13,680 Litres of water were removed from the well in that time. As such, the amount of water taking in six hours exceeds the expected daily water taking for the full development ... the well is capable of meeting the expected daily water demand."*

As stated in the Hydrogeology and Terrain Study, prepared by Kollaard Associates (File No: 230403, dated November 13, 2023):

*"The water quality as determined from the results of the analyses is acceptable. The water meets all the Ontario Drinking Water Standards (ODWS) health and aesthetic parameters tested for at the test well except for aesthetic objective for hardness, Iron, Manganese, TDS [total dissolved solids], Turbidity (lab measured) and Antimony. Sodium in the raw water supply exceeds the 20 mg/L medical advisory level for those on medically restricted low sodium diets."*

Kollaard proposed possible water treatment for the hardness, iron, manganese, and TDS. Turbidity was lab measured and is not considered to be representative of the field readings. Kollaard noted only one sample exceeded the standard for Antimony and the exceedance is marginal. Based on additional testing Kollaard noted that *"the well water does not have antimony present above allowable limits"*. Kollaard also noted that; *"Based on what is known about the wells in the area, it is unlikely that antimony is sourced in the groundwater as the recent result indicates that antimony was not present. It is more likely that antimony was present from corrosion in plumbing materials rather than from the water. Antimony is unlikely to be naturally present in groundwater at levels that are above the guidelines."*

### 3.0 SANITARY SERVICING

An on-site sewage (septic) system is proposed.

The total daily design sewage flow (TDDSF) of 8,615 L/day was calculated for all proposed buildings (Phase 1 and 2 buildings) in accordance with the Part 8 of the Ontario Building Code (OBC) as follows:

Phase 1 Building:

Offices Area:

The greater of:

30 employees x 75 L/day per employee = 2,250 L/day

or

277.3 m<sup>2</sup> of offices x 75 L/day per 9.3 m<sup>2</sup> = 2,236 L/day

Factory Area:

18 employees x 75 L/day per employees = 1,350 L/day

Warehouse Areas:

18 loading bays = 18 x 150 l/day = 2,700 L/day

TDDSF (Phase 1):

Office (2,250 L/day) + Factory (1,350 L/day) + Warehouse (2,700 L/day) = 6,300 L/day

Phase 2 Building:

Offices Area:

The greater of:

4 employees x 75 L/day per employee = 300 L/day

or

45.3 m<sup>2</sup> of offices x 75 L/day per 9.3 m<sup>2</sup> = 365 L/day

Factory Area:

8 employees x 75 L/day per employees = 600 L/day

Warehouse Areas:

9 loading bays = 9 x 150 l/day = 1,350 L/day

TDDSF (Phase 2):

Office (365 L/day) + Factory (600 L/day) + Warehouse (1,350 L/day) = 2,315 L/day

TOTAL DAILY SEWAGE DESIGN FLOW (Phase 1 + 2):

= 6,300 L/day + 2,315 L/day = 8,615 L/day

As stated in the Hydrogeology and Terrain Study, prepared by Kollaard Associates (File No: 230403, dated November 13, 2023): *"The sewage system that is proposed for the development is an EcoFLO tertiary treatment system that is expected to reduce nitrates to 20 mg/L (50% denitrification)."*

The proposed on-site septic system will be a Class 4 system sized for a daily design sanitary sewage flow of 8,615 L/day; consisting of a minimum 25,846 L (3 x TDDSF) septic tank; a minimum 3,000 L time-dosing pump tank; four ECOFLO 650BR biofilter treatment units (each having a 2,500 L capacity – with time dosing); and a Type 'A' dispersal bed.

The proposed on-site septic system will be a Class 4 system sized for a daily design sanitary sewage flow of 8,615 L/day; consisting of a minimum 25,846 L (3 x TDDSF) septic tank; a minimum 3,000 L time-dosing pump tank; four ECOFLO 650BR biofilter treatment units (each having a 2,500 L capacity – with time dosing) with an ECOFLO Denitrification Unit certified for 50% reduction in nitrates as per NSF/ANSI Standard 245); and a Type 'A' dispersal bed.

To prevent having an adverse effect on the bacterial action in the septic system, floor drains will drain to the roadside ditch via an oil interceptor. The proposed floor drains will have a sump below the outlet designed to trap sand and grit in the sump so that they do not enter the oil interceptor. The oil interceptor in each building will be sized for design flow rate of 35 lpm or 132 L/min (which is over 3 times the 38 L/min pumping rate during Kollaard's pumping test): CAPTEURS GR Model GR-5035 oil interceptor having an oil capacity of 90 litres or approved equal. Refer to Appendix B.

An application for a septic permit will be submitted to the Ottawa Septic System Office (OSSO).

#### **4.0 STORMWATER MANAGEMENT**

##### **4.1 QUALITY CONTROL**

The City of Ottawa requires an enhanced level of protection with 80% total suspended solids (TSS) removal from the rainwater runoff. To meet the water quality target of 80% TSS removal an oil grit separator (OGS) is proposed to be located downstream of the inlet control device (ICD). A CDS Model PMSU2015-5-C was selected by the manufacturer based on the manufacturer's software which calculated that it would remove 85% of the TSS. Refer to Appendix C. The OGS has an oil capacity of 376 L and a sediment capacity of 1.1 m<sup>3</sup>.

As is typical of other sites in the area an infiltration component is proposed for temperature mitigation (the property is within the Huntley Creek Subwatershed which is a cool water system), and for groundwater recharge.

Rainfall runoff from about 87% of the developable portion of the property and virtually all of the hard surfaces (over 99%) will drain to the infiltration trench. As per the MOE Stormwater Management Planning and Design Manual; if an infiltration trench is being used to treat stormwater runoff from roads and parking lots, pre-treatment is necessary to minimize the potential for suspended sediments to clog the trench. Virtually all the hard surfaces draining to the stormwater detention area will drain to it via a storm sewer system which includes 29 catch basin / catch basin manholes. The 600 mm sumps in each catch basin and the 300 mm sump in each catch basin / manholes will tend to remove coarse sediment from runoff. For the infiltration trench to function adequately, the sumps, trench and detention area requires regular maintenance: Annually, in the spring (and more frequently if necessary), any accumulated sediment needs to be removed from the sumps and surface of the infiltration trench. Also, about once every five years (more frequently if ponding is observed during non-freezing conditions), the top 50 mm of clear stone (above the geotextile fabric) should be removed and replaced; and any geotextile material that has been damaged also be replaced.

Promoting runoff to infiltrate into the ground is an effective method to achieve temperature mitigation and groundwater recharge. Water will be stored to a depth of 200 mm above the infiltration trench (and below the invert of outlet pipe) providing 169.6 m<sup>3</sup> storage, which is the volume required to capture the entire runoff from a 5 mm rainfall event (refer to Appendix C). In Ottawa, rainfall in 64% of days with precipitation is less than 5 mm; therefore, the entire runoff from the majority of rainfall events will infiltrate into the ground.

Under Kollaard Associates direction, four boreholes located within the footprint of the proposed infiltration trench (which is within the stormwater detention area), was drilled to determine the subsurface soil profile and depth to groundwater. As per Kollaard's borehole log records subsurface conditions consisted of a 1.4 m to 1.5 m layer of sand and gravel fill materials overlying layer of native silt with trace sand to depth of at least 3 m; and depth to groundwater varied from 1.1 m (May 30, 2023) to 1.6 m (November 30, 2023) to 0.5 m to 0.74 m (May 24/27, 2024). Based on soil sample obtained by Kollaard Associates at about 1.7 m depth (considered to be representative of the subsurface conditions within 1.0 metres of the underside of the proposed infiltration trench) a Grain Size Distribution and Particle Size Analysis were conducted by Stantec (refer to Appendix C). The result of the analysis indicates that the subsurface soils consist of about 12% sand, 56% silt and 32% clay. Based on the tested properties of the soil samples obtained, using the

unified soil classification system, the soil is classified as ML (which includes silts, very fine sands, silty or clayey sands and clayey silts). From the OBC Volume 2 Supplementary Standard SB-6, Chart 9 and Table 3, these soils at the site will have an estimated Percolation Time, T-time of 20 to 50 min/cm or a Coefficient of Permeability  $10^{-5}$  to  $10^{-6}$  cm/sec. The following table obtained from the Low Impact Development Stormwater Management Planning and Design Guide - Appendix C produced by Credit Valley Conservation and Toronto and Region Conservation indicates the relationship between the Percolation Time, Coefficient of Permeability and Infiltration Rate.

**Table C1: Approximate relationships between hydraulic conductivity, percolation time and infiltration rate**

Hydraulic Conductivity, Kfs (centimetres/second)	Percolation Time, T (minutes/centimetre)	Infiltration Rate, 1/T (millimetres/hour)
0.1	2	300
0.01	4	150
0.001	8	75
0.0001	12	50
0.00001	20	30
0.000001	50	12

From the above table, the native soils within 1 metre of the bottom of the infiltration trenches have an estimated infiltration rate of 12 to 30 mm/hr. However, since the above soil analysis was conducted Kollaard have completed conductivity tests (refer to Appendix C) and they have estimated that the soils have an infiltration rate of 30 to 50 mm/hr, which are used. However, as per the City of Ottawa LID Technical Guidance Report a factor of safety should be considered; so safety correction factor of 2.5 has been applied to the estimated infiltration rates. Therefore, the design infiltration rates are 12 to 20 mm/hr; and the 200 mm depth of water above the trench, will have a drawdown time of 10 to 16.7 hours. (MOE Stormwater Management Planning and Design Manual recommends a maximum drawdown time of 24 to 48 hours.)

The bottom of the clear stone in the infiltration trench will be 0.54 m to about 1.5 m above the measured groundwater level; and the recommended minimum as per the MOE Stormwater Management Planning and Design Manual is 1.0 m. However, the 'City of Ottawa Low Impact Development Technical Guidance Report Implementation in Areas with Potential Hydrogeological Constraints' states: "... while the function of some infiltration-based LID options may be limited during seasonal high groundwater conditions (i.e., during spring freshet conditions), they may still be feasible during the remainder of the year ... Seasonally high groundwater conditions may not completely exclude the use of infiltration-based LIDs ... seasonal groundwater conditions can be assessed and may indicate that poor infiltration conditions may be limited to a single season (i.e. spring) and/or represent only a portion of the total year." As per Kollaard's borehole log records it is apparent that during some spring seasons (e.g. in 2024 but not 2023) the high groundwater may result infiltration conditions that are less than ideal, however, the conditions are acceptable during other times. Furthermore, the infiltration trench is not primarily designed for quality control (the proposed OGS manhole will provide the quality control) or quantity control (only 8% of the required storage relies on infiltration); the infiltration trench is designed to provide temperature mitigation and to meet annual infiltration targets; in addition, the trenches have a drawdown time of 10 to 16.7 hours (significantly less than the recommended maximum of 24 to 48 hours); therefore, given all of the above rationale, groundwater mounding is not a concern, a groundwater mounding analysis is not required, and the proposed design should be considered acceptable. The alternative, which is not feasible, would be to raise the site, and building, a further 0.5 m, or about 2.0 m above existing grades and 2.0 m above the grades of the property immediately to the south.

As per the geotechnical report bedrock is about 6 to 8 m below the existing grade; therefore, bedrock is not an issue.

As per the Ministry of Environment, Conservation and Parks' (MECP's) Source Protection Information Atlas, the source protection plan for the subject property is the Mississippi-Rideau Source Protection Plan; and

as per this plan the subject property is within a Significant Groundwater Recharge Area with a score of 6 and within an area that has a Highly Vulnerable Aquifer with a score of 6. Therefore, spills potentially entering the groundwater via an infiltration trench can be a concern. Within the building; any spills caused by equipment maintenance will drain to the previously described oil interceptor located inside the building. Outside the building fluids leaking from vehicles may be possible. Regardless, as is required by the Environmental Compliance Approval (ECA – see page 6), within six months from the issuance of an ECA, the owner is required to implement a spill contingency plan that includes a set of procedures describing how to mitigate the impacts of a spill. Among other items, the spill contingency plan would include:

- a site plan showing buildings, streets, drainage patterns, the infiltration trench and any other feature that could potentially be significantly impacted by a spill;
- physical obstructions and location of response and clean-up equipment;
- steps to be taken to report, contain, clean up and dispose of contaminants following a spill;
- a listing of telephone numbers for local clean-up company(ies) who may be called upon to assist in responding to spills; local emergency responders including health institution(s); and Ministry Spills Action Centre 1-800-268-6060;
- Safety Data Sheets (SDS) for each hazardous material which may be transported or stored within the area;
- the means (internal corporate procedures) by which the spill contingency plan is activated;
- a description of the spill response training provided to employees and the date(s) on which the training was provided and by whom; and
- an inventory of response and clean-up equipment available to implement the spill.

The spill contingency plan has to be kept in a conspicuous, readily accessible location on-site; and the plan needs to be amended as required by changes in the operation of the facility.

An erosion and sediment control plan has been developed to be implemented during construction, (see drawing C-13 and notes 2.1 to 2.8 on drawing C-15). In summary: to filter out construction sediment a silt fence barrier will be installed around the perimeter of the site where runoff will drain off the site, straw bale check dams will be installed at culverts, a mud mat will be installed at the egress point, sediment capture filter sock inserts are to be installed in all new catch basins as they are installed, and any material deposited on a public road will be removed.

#### 4.2 QUANTITY CONTROL

As per the pre-consultation meeting with City staff, the stormwater quantity control measures are based on the post development release rate for the 2 and 100-year storm events being controlled to the to peak flows during the 2-year storm event using a pre-development runoff coefficient or 0.50 (whichever is less); and a calculated time of concentration (but not less than 10 minutes). It is determined that pre-development condition reflected a runoff coefficient of 0.30 (as per City of Ottawa Sewer Design Guidelines, Table 5.7 – a pasture); and, using the Airport Formula, the time of concentration was 30 minutes. Using the Rational Method, and a time of concentration of 30 minutes, the pre-development 2-year peak flow is 155.44 L/s. Therefore, the maximum allowable release rate is 155.44 L/s for all storm events up to the 100-year event. Refer to calculations in Appendix C.

Stormwater will be stored within the development on the surface above catch basins and in a stormwater detention area. The stormwater released from the detention area will discharge to the Wescar Lane roadside ditch. The Modified Rational Method is used to calculate the required storage volume. The runoff coefficients for the 100-year event are increased by 25% to maximum 1.00.

#### Drainage Area I (Uncontrolled Flow Off Site – 6,165 m<sup>2</sup>)

Areas around the perimeter of the property will drain uncontrolled off site. The flow rates are calculated at a time of concentration of 10 minutes.

	100-Year Event	2-Year Event
Maximum Flow Rate	87.86 L/s	30.89 L/s



### Drainage Area II (40,103 m<sup>2</sup>)

An inlet control device (ICD) located in the inlet of the culvert in the stormwater detention area will control the release of stormwater from the property and will discharge to the roadside ditch near the southeast corner of the property. The ICD will restrict the flow and force the stormwater to rise in the detention area. The ICD shall be a plug style with a round orifice design manufactured by Pedro Plastics (or approved equal) and each shall be sized by the manufacturer for a discharge rate of 55.39 L/s at 1.88 m head. It is calculated that an orifice area of 14,944 mm<sup>2</sup> ( $\pm$ 138 mm diameter) and a discharge coefficient of 0.61 will restrict the outflow rate to 56.39 L/s at a head of 1.88 m. Based on this orifice the maximum outflow rate for the 2-year storm event is calculated to be 30.82 L/s at 0.58 m. A broad-crested weir will control the release of stormwater to the roadside ditch in the event that the 100-year storm is exceeded (or if there is blockage). The broad-crested weir will be a concrete curb with an 8.0 m long depressed section set at the 100-year ponding elevation of 122.18. The weir, for example, would release 56.39 L/s (the 100-year ICD outflow rate) at 0.026 m water depth above the weir.

	100-Year Event	2-Year Event
Maximum ICD Release Rate	56.39 L/s	31.40 L/s
Maximum Ponding Elevation	122.18 m	121.69 m
Maximum Volume Stored	2,027.09 m <sup>3</sup>	735.66 m <sup>3</sup>

### Entire Site

	100-Year Event	2-Year Event
Pre-Development Flow Rate	476.49 L/s	155.44 L/s
Maximum Allowable Release Rate	155.44 L/s	155.44 L/s
Maximum Release Rate	143.25 L/s	61.71 L/s
Maximum Volume Required & Stored	2,022.78 m <sup>3</sup>	734.61 m <sup>3</sup>

The maximum post-development release rate during the 100-year event was calculated to be 70% less than the pre-development flow rate and 8% less than the maximum allowable release rate. To achieve the maximum allowable release rate, a maximum storage volume of 2,023 m<sup>3</sup> is required and provided. The maximum post-development release rate during the 2-year event was calculated to be 60% less than the pre-development flow rate and the maximum allowable release rate. The proposed stormwater management quantity control measures are expected to have a positive impact on the downstream municipal infrastructure.

It is expected that the Ministry of Environment, Conservation and Parks (MECP) will consider the property "industrial lands" and an Environmental Compliance Approval (ECA) will be required for the proposed stormwater management facility.

## 4.2 STORM SERVICING

Stormwater will be conveyed off the site via a proposed storm sewer system draining to the stormwater detention area and outletting to the Wescar Lane roadside ditch. The unrestricted flowrate resulting from 2-year storm event will produce a peak flow of 502.80 L/s resulting in the last pipe segment being 169% full. However, the restricted flow through the ICD will restrict the flow to a maximum flow of 31.40 L/s so that the last pipe segment will only be 11% full. Refer to calculations in Appendix D.

## 5.0 CONCLUSIONS

1. Six 45,000 L (10,000 gallon) tanks are proposed for a total of 270,000 L. This exceeds the 267,339 L that is required. Two tanks (one at each end of the row of tanks) will be equipped with draw pipes, and a remote fire hydrant and two on-site fire hydrants are proposed.
2. As discussed with the OFS, a pumper truck is capable of drawing 4,500 L/min, typically at 70 psi; and based on 4,500 L/min at 70 psi at the remote fire hydrant (FH-2), the pressure at the fire hose connection at FH-2 is calculated to be 24.2 psi. and 29.7 psi at FH-3. Since the pressures are at least 138 kPa (20 psi), the private watermains are adequately sized
3. As stated in the Hydrogeology and Terrain Study *“the well is capable of meeting the expected daily water demand ... The water quality as determined from the results of the analyses is acceptable.”*
4. An on-site septic system is proposed. The total daily design sewage flow (TDDSF) of 8,615 L/day was calculated for all proposed buildings. As stated in the Hydrogeology and Terrain Study: *“The sewage system that is proposed for the development is an EcoFLO tertiary treatment system that is expected to reduce nitrates to 20 mg/L (50% denitrification).”* An application for a septic permit will be submitted to the Ottawa Septic System Office (OSSO).
5. To achieve quality control as part of the stormwater management design, an oil grit separator (OGS) manhole, designed to remove 80% TSS, is proposed.
6. An infiltration trench is proposed for temperature mitigation and for groundwater recharge.
7. An Erosion & Sediment Control Plan has been developed to be implemented during construction.
8. The maximum post-development release rate during the 100-year event was calculated to be 70% less than the pre-development flow rate and 8% less than the maximum allowable release rate. To achieve the maximum allowable release rate, a maximum storage volume of 2,027 m<sup>3</sup> is required and provided. The maximum post-development release rate during the 2-year event was calculated to be 60% less than the pre-development flow rate and the maximum allowable release rate. The proposed stormwater management quantity control measures are expected to have a positive impact on the downstream municipal infrastructure.
9. It is expected that the Ministry of Environment, Conservation and Parks (MECP) will consider the property “industrial lands” and an Environmental Compliance Approval (ECA) will be required for the proposed stormwater management facility.

Prepared by D.B. Gray Engineering Inc.



NOT VALID UNLESS  
SIGNED & DATED

## **APPENDIX A**

### WATER SERVICING

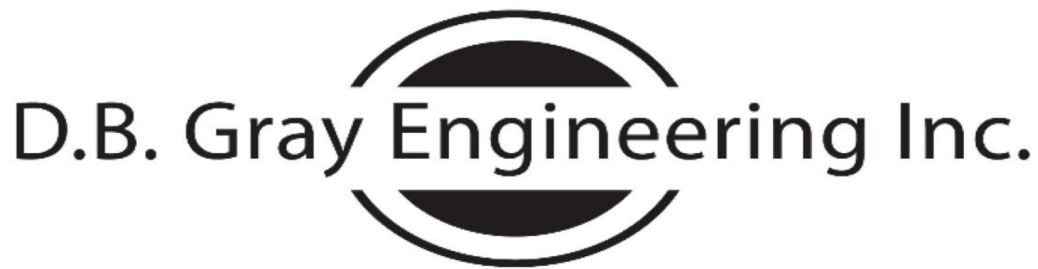

*Stormwater Management - Grading & Drainage - Storm & Sanitary Sewers - Watermains*

700 Long Point Circle  
Ottawa, Ontario K1T 4E9

613-425-8044  
d.gray@dbgrayengineering.com

August 15, 2023  
REVISED January 10, 2024

## 151-159 Wescar Lane PHASE 1 BUILDING 'A' - 2-Storey Office Ottawa, Ontario

### FIRE FLOW CALCULATIONS OBC Method

As per "Required Minimum Water Supply Flow Rate" as calculated using the Ontario Building Code - Appendix A - Article A-3.2.5.7 "Water Supply For Fire Fighting".

K = Water supply coefficient as per OBC A-3.2.5.7. Table 1  
= 10 Group D Occupancy, Building is of noncombustible construction with fire separations without fire resistance ratings.

V = Building volume in cubic meters

Footprint Area (sq.m)	Height (m)	Volume (cu.m)
763	7.64	5,834

S<sub>Total</sub> = Total of spatial coefficients from exposure distances

$$= 1.0 + S_{\text{Side 1}} + S_{\text{Side 2}} + S_{\text{Side 3}} + S_{\text{Side 4}}$$

	Spatial Coefficient	Exposure Distance (m)	
S <sub>Side 1</sub>	0.0	76	(to N property line)
S <sub>Side 2</sub>	0.0	32	(to centerline Wescar Ln)
S <sub>Side 3</sub>	0.0	38	(to S property line)
S <sub>Side 4</sub>	0.0		(to 2 hr firewall)
S <sub>Total</sub>	1.0		

Q = KVS<sub>Tot</sub> (required water supply in litres)

$$Q = 58,339 \text{ L}$$

$$= 2,700 \text{ L/min as per OBC A-3.2.5.7. Table 2}$$

$$= 45 \text{ L/s}$$

Q = 81,000 L (minimum)      Duration: 30 minutes (minimum 30 minutes)

# D.B. Gray Engineering Inc.

*Stormwater Management - Grading & Drainage - Storm & Sanitary Sewers - Watermains*

700 Long Point Circle  
Ottawa, Ontario K1T 4E9

613-425-8044  
d.gray@dbgrayengineering.com

August 15, 2023

**151-159 Wescar Lane**  
**PHASE 1 BUILDING 'B' - 1-Storey Warehouse + Mezanine**  
Ottawa, Ontario

## FIRE FLOW CALCULATIONS OBC Method

As per "Required Minimum Water Supply Flow Rate" as calculated using the Ontario Building Code - Appendix A - Article A-3.2.5.7 "Water Supply For Fire Fighting".

K = Water supply coefficient as per OBC A-3.2.5.7. Table 1  
= 17 Group F-2 Occupancy, Building is of noncombustible construction with fire separations without fire resistance ratings.

V = Building volume in cubic meters

Footprint Area (sq.m)	Average Height (m)	Volume (cu.m)
1,081	10.50	11,354

S<sub>Total</sub> = Total of spatial coefficients from exposure distances

$$= 1.0 + S_{\text{Side 1}} + S_{\text{Side 2}} + S_{\text{Side 3}} + S_{\text{Side 4}}$$

	Spatial Coefficient	Exposure Distance (m)	
S <sub>Side 1</sub>	0.0	76	(to N property line)
S <sub>Side 2</sub>	0.0		(to 2 hr firewall)
S <sub>Side 3</sub>	0.0	38	(to S property line)
S <sub>Side 4</sub>	0.0		(to 2 hr firewall)
S <sub>Total</sub>	1.0		

Q = KVS<sub>Tot</sub> (required water supply in litres)

$$Q = 193,023 \text{ L}$$

$$= 6,300 \text{ L/min as per OBC A-3.2.5.7. Table 2}$$

$$= 105 \text{ L/s}$$

Q = 193,023 L (minimum)    Duration: 31 minutes (minimum 30 minutes)

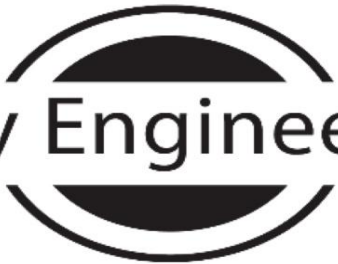

# D.B. Gray Engineering Inc.

*Stormwater Management - Grading & Drainage - Storm & Sanitary Sewers - Watermains*

700 Long Point Circle  
Ottawa, Ontario K1T 4E9

613-425-8044  
d.gray@dbgrayengineering.com

August 15, 2023

151-159 Wescar Lane  
PHASE 1 BUILDING 'C' - 1-Storey Warehouse + Mezanine  
Ottawa, Ontario

## FIRE FLOW CALCULATIONS OBC Method

As per "Required Minimum Water Supply Flow Rate" as calculated using the Ontario Building Code - Appendix A - Article A-3.2.5.7 "Water Supply For Fire Fighting".

K = Water supply coefficient as per OBC A-3.2.5.7. Table 1  
= 17 Group F-2 Occupancy, Building is of noncombustible construction with fire separations without fire resistance ratings.

V = Building volume in cubic meters

Footprint Area (sq.m)	Average Height (m)	Volume (cu.m)
1,497	10.50	15,726

S<sub>Total</sub> = Total of spatial coefficients from exposure distances

$$= 1.0 + S_{\text{Side 1}} + S_{\text{Side 2}} + S_{\text{Side 3}} + S_{\text{Side 4}}$$

	Spatial Coefficient	Exposure Distance (m)	
S <sub>Side 1</sub>	0.0	76	(to N property line)
S <sub>Side 2</sub>	0.0		(to 2 hr firewall)
S <sub>Side 3</sub>	0.0	38	(to S property line)
S <sub>Side 4</sub>	0.0	83.0	(to W property line)
S <sub>Total</sub>	1.0		

Q = KVS<sub>Tot</sub> (required water supply in litres)

Q = 267,339 L  
= 6,300 L/min as per OBC A-3.2.5.7. Table 2  
= 105 L/s

Q = 267,339 L (minimum) Duration: 42 minutes (minimum 30 minutes)



*Stormwater Management - Grading & Drainage - Storm & Sanitary Sewers - Watermains*

700 Long Point Circle  
Ottawa, Ontario K1T 4E9

613-425-8044  
d.gray@dbgrayengineering.com

August 15, 2023  
REVISED January 10, 2024

## 151-159 Wescar Lane

### PHASE 2 BUILDING 1-Storey Office / Warehouse + Mezanine

Ottawa, Ontario

## FIRE FLOW CALCULATIONS

### OBC Method

As per "Required Minimum Water Supply Flow Rate" as calculated using the Ontario Building Code - Appendix A - Article A-3.2.5.7 "Water Supply For Fire Fighting".

K = Water supply coefficient as per OBC A-3.2.5.7. Table 1  
= 17 Group F-2 Occupancy, Building is of noncombustible construction with fire separations without fire resistance ratings.

V = Building volume in cubic meters

Footprint Area (sq.m)	Average Height (m)	Volume (cu.m)
1,128	10.50	11,849

$S_{Total}$  = Total of spatial coefficients from exposure distances

$$= 1.0 + S_{Side\ 1} + S_{Side\ 2} + S_{Side\ 3} + S_{Side\ 4}$$

	Spatial Coefficient	Exposure Distance (m)	
$S_{Side\ 1}$	0.0	34	(to N property line)
$S_{Side\ 2}$	0.0	27	(to E property line)
$S_{Side\ 3}$	0.0	141	(to PH1 Building)
$S_{Side\ 4}$	0.0	55	(to W property line)
$S_{Total}$	1.0		

Q =  $KVS_{Tot}$  (required water supply in litres)

$$Q = 201,433\ L$$

$$= 6,300\ L/min\ \text{as per OBC A-3.2.5.7. Table 2}$$

$$= 105\ L/s$$

Q = 201,433 L (minimum)    Duration: 32 minutes (minimum 30 minutes)



Douglas Gray &lt;d.gray@dbgrayengineering.com&gt;

---

**RE: 151-159 Wescar Lane**

1 message

**Evans, Allan** <Allan.Evans@ottawa.ca>

Thu, Jul 11, 2024 at 1:55 PM

To: Douglas Gray &lt;d.gray@dbgrayengineering.com&gt;

Cc: "Whittaker, Damien" &lt;Damien.Whittaker@ottawa.ca&gt;, Keith Riley &lt;keith@argueconstruction.ca&gt;, Shawn Argue &lt;Shawn@argueconstruction.ca&gt;, "Mark.Watson@Sunbeltrentals.com" &lt;mark.watson@sunbeltrentals.com&gt;, Mark Smith &lt;mark.smith2@sunbeltrentals.com&gt;, Ryan Faith &lt;r.faiht@dbgrayengineering.com&gt;, laurent Brosseau &lt;l.brosseau@dbgrayengineering.com&gt;

Hi Doug – the process has been modified from the previous iteration (apologies – this was a work in progress and clarification was needed from building code services around the Q value intent). The flowchart below is to be considered DRAFT and subject to change until such time as it is officially released in the new tech bulletin, but this should be very close (likely exactly) to what appears in the final release.

The biggest changes come from us wanting to provide some storage credit for sites that meet the FUS requirements for superior tanker shuttle. Specifically the site must be within 5km of a fire station and 2.5 km of an approved water source (ie: large lake, pressurized hydrant typically). Unfortunately this site does not meet the FUS requirements (nearest fire station is 7.4km and the nearest water source is 2.9km) so no reduction of the Q value will be permitted.

Since the fire flow is below the 9000 L/min OBC maximum, the OBC calculation still applies and 2 draft points from a shared storage tank system is required. We will work out the layout of this separately based upon your site plan – please contact me further to discuss.

**Required Storage = Q = 267 339 L with two draft points**

Damien – anything further you require from OFS?



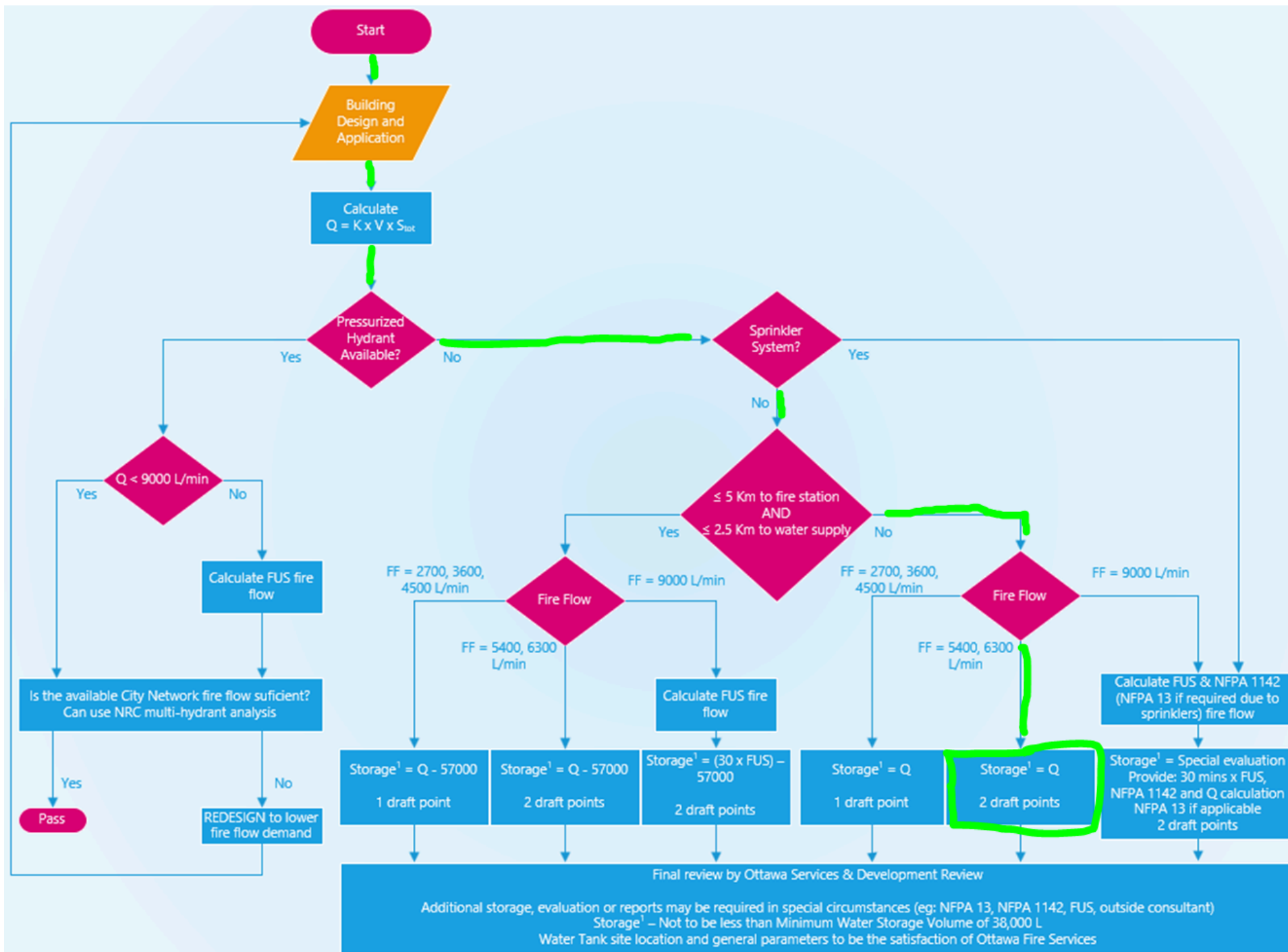

Ottawa Fire Station 81, 1641 Stittville 



151 Wescar Ln, Carp, ON K0A 1L0 

 Add destination

---

Leave now  [Options](#)







---

 [Send directions to your phone](#)  [Copy link](#)

---

 **via Carp Rd/Route 5** **11 min**  
Fastest route, despite the usual traffic **7.4 km**  
[Details](#)

---

Best 4 min 40 min 10 min —

151 Wescar Ln, Carp, ON K0A 1L0 



2145 Carp Rd, Carp, ON K0A 1L0

 Add destination

---

Leave now  [Options](#)

---

 [Send directions to your phone](#)  [Copy link](#)

---

 **via Carp Rd/Route 5** **4 min**  
Fastest route, despite the usual traffic **2.9 km**

$Q = KVS_{Tot}$  (required water supply in litres)

$Q = 267,339$  L

$= 6,300$  L/min as per OBC A-3.2.5.7. Table 2  
(less than 9,000 L/min; therefore, FUS calculations are not required)

$Q = 189,000$  L (minimum storage for 30 minute supply)

*Allan Evans*

Fire Protection Engineer / Ingénieur de Protection d'Incendies

Prevention Division / Prévention des Incendies

Ottawa Fire Services / Service des Incendies d'Ottawa

1445 Carling Avenue / 1445 Avenue Carling

Ottawa, ON K1Z 7L9

Allan.Evans@Ottawa.ca

☎ (613) 913-2747 | ☎ (613) 580-2424 x24119 | ☎ (613) 580-2866 | ✉ Mail Code: 25-102 | @OFSFPE



An internationally accredited agency 2019-2024



OTTAWA FIRE SERVICES  
SERVICE DES INCENDIES D'OTTAWA

Protecting Our Nation's Capital With Honour  
Protéger notre capitale nationale avec honneur

**From:** Douglas Gray <d.gray@dbgrayengineering.com>

**Sent:** July 10, 2024 5:28 PM

**To:** Evans, Allan <Allan.Evans@ottawa.ca>

**Cc:** Whittaker, Damien <Damien.Whittaker@ottawa.ca>; Keith Riley <keith@argueconstruction.ca>; Shawn Argue <Shawn@argueconstruction.ca>; Mark.Watson@Sunbeltrentals.com; Mark Smith <mark.smith2@sunbeltrentals.com>; Ryan Faith <r.faith@dbgrayengineering.com>; laurent Brosseau <l.brosseau@dbgrayengineering.com>

**Subject:** Re: 151-159 Wescar Lane

**CAUTION: This email originated from an External Sender. Please do not click links or open attachments unless you recognize the source.**

**ATTENTION : Ce courriel provient d'un expéditeur externe. Ne cliquez sur aucun lien et n'ouvrez pas de pièce jointe, excepté si vous connaissez l'expéditeur.**

Hi Allan

Have you had a chance to review our calculations?

Regards, Doug

Douglas Gray

**D. B. Gray Engineering Inc.**

[700 Long Point Circle](#)

[Ottawa, ON K1T 4E9](#)

613-425-8044

On Wed, Jun 19, 2024 at 9:18 AM Douglas Gray <[d.gray@dbgrayengineering.com](mailto:d.gray@dbgrayengineering.com)> wrote:

Hi Allan

Attached are our fire flow / storage calculations for [151-159 Wescar Lane](#) based on the OFS proposal. .

We have calculated that the required fire flow is 6,300 L/min and based on a 30 minute supply the minimum required storage volume is 189,000 L (with two draft points).

Please review and comment before we revise and submit our drawings.

Thanks, Doug

Douglas Gray

**D. B. Gray Engineering Inc.**

[700 Long Point Circle](#)

[Ottawa, ON K1T 4E9](#)

613-425-8044

This e-mail originates from the City of Ottawa e-mail system. Any distribution, use or copying of this e-mail or the information it contains by other than the intended recipient(s) is unauthorized. Thank you.

Le présent courriel a été expédié par le système de courriels de la Ville d'Ottawa. Toute distribution, utilisation ou reproduction du courriel ou des renseignements qui s'y trouvent par une personne autre que son destinataire prévu est interdite. Je vous remercie de votre collaboration.

8/23/24, 8:46 AM

D.B. Gray Engineering Inc. Mail - RE: 151-159 Wescar Lane

 **Gray Eng 151-159 Wescar Ln PH1 Building C OBC Fire Flow Calcs Jun19-24.pdf**  
77K

## **APPENDIX B**

### SANITARY SERVICING

## GR-5000 SERIES

### Certified oil interceptor

For occasional automobile mechanics, such as body workshops, car windows, aesthetics, etc.

The interceptor is made of steel coated with enamel antirust paint, including a flow rate regulator, a 2" blowhole at the entrance and exit, a non-skid cover bolted airtight. A warning signal is built in a PVC case ULC + CSA approved to be fixed to the workshop wall (pre-fabricated at factory) and is connected to the interceptor using a 10 foot teck that is buried underground.

A 115 Volt – 15 Amp outlet is required at the workshop for the warning signal. The oil interceptor must be drained at least once a year.

Note: A sand interceptor is required upstream the oil interceptor, with an appropriate capacity (GR-520 series) and has to be drained more frequently to avoid any overflow. (4.7.6)

### OPTIONS(SUFFIX)

- E:** Extension (dim. 'C' specify)
- LP:** Thermal epoxy coated
- SS:** Stainless steel
- XH:** Extra heavy traffic cover
- GRP:** Made of polypropylene
- SB:** Steel sediment basket
- TECK:** Total length wire

### TECHNICAL DRAWINGS

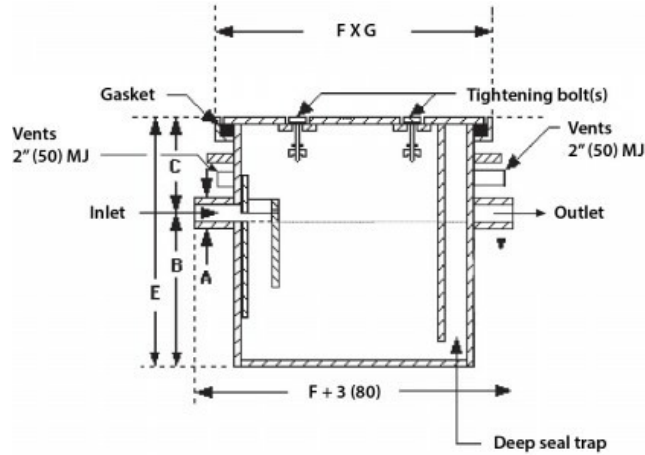

### SPECIFICATIONS

	Model	GPM	Nom. Dia. M.J.			Dimension			Used oil	Weight	Car Unit
			A	B	C	height	length	width			
						E	F	G			
Unit			<i>in (mm)</i>	<i>in (mm)</i>	<i>in (mm)</i>	<i>in (mm)</i>	<i>in (mm)</i>	<i>in (mm)</i>	<i>gallons (litres)</i>	<i>lbs (kg)</i>	
<input type="checkbox"/>	GR-5020	20	3 (75)	14 (360)	6 (150)	20 (500)	32 (810)	24 (610)	20 (90)	190 (86)	1
<input type="checkbox"/>	GR-5025	25	3 (75)	16 (405)	6 (150)	22 (550)	32 (810)	24 (610)	20 (90)	200 (91)	2
<input checked="" type="checkbox"/>	GR-5035	35	3 (75)	19 (480)	6 (150)	25 (635)	32 (810)	24 (610)	20 (90)	215 (98)	3
<input type="checkbox"/>	GR-5050	50	4 (100)	24 (610)	6 (150)	30 (760)	32 (810)	24 (610)	20 (90)	240 (109)	4
<input type="checkbox"/>	GR-5060	60	4 (100)	35 (890)	6 (150)	41 (1040)	32 (810)	24 (610)	20 (90)	295 (134)	5
<input type="checkbox"/>	GR-5075	75	4 (100)	24 (610)	6 (150)	30 (760)	44 (1120)	32 (810)	50 (225)	375 (170)	6

## **APPENDIX C**

### STORMWATER MANAGEMENT



# VERIFICATION STATEMENT

## GLOBE Performance Solutions

Verifies the performance of

### CDS Hydrodynamic Separator®

Developed by CONTECH Engineered Solutions LLC  
Scarborough, Maine, USA

**Registration: GPS-ETV\_VR2020-03-31\_CDS**

In accordance with

**ISO 14034:2016**

**Environmental Management —  
Environmental Technology Verification (ETV)**



John D. Wiebe, PhD  
Executive Chairman  
GLOBE Performance Solutions

March 31, 2020  
Vancouver, BC, Canada



Verification Body  
GLOBE Performance Solutions  
404 – 999 Canada Place | Vancouver, B.C | Canada |V6C 3E2

## Technology description and application

The CDS® is a Stormwater treatment device designed to remove pollutants, including sediment, trash and hydrocarbons from Stormwater runoff. The CDS is typically comprised of a manhole that houses flow and screening controls that use a combination of swirl concentration and continuous deflective separation.

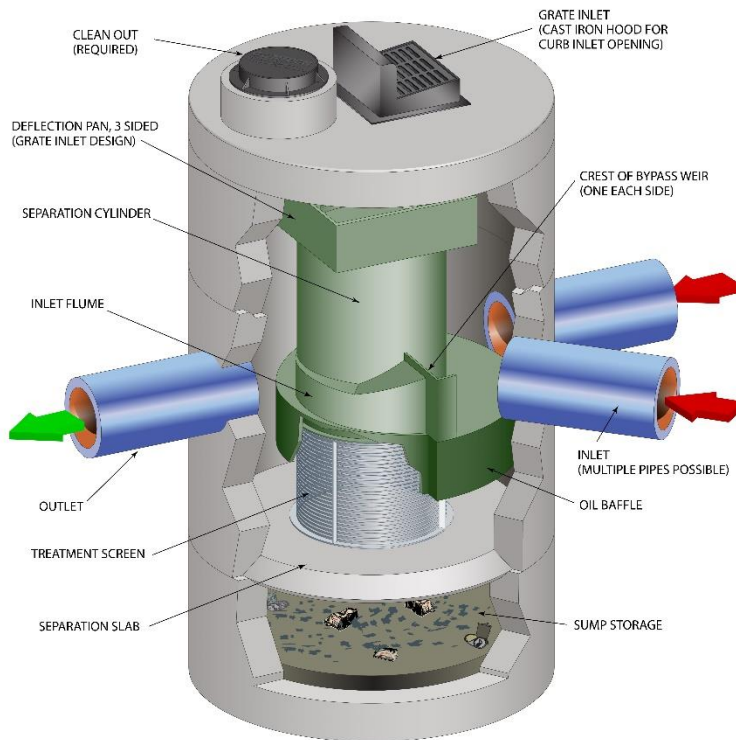

Figure 1. Graphic of typical inline CDS unit and core components.

When stormwater runoff enters the CDS unit's diversion chamber, the diversion pan guides the flow into the unit's separation chamber. The water and associated gross pollutants contained within the separation cylinder are kept in continuous circular motion by the energy generated from the incoming flow. This has the effect of a continuous deflective separation of the pollutants and their eventual deposition into the sump storage below. A perforated screen plate allows the filtered water to pass through to a volute return system and thence to the outlet pipe. The oil and other light liquids are retained within the oil baffle. Figure 1 shows a schematic representation of a typical CDS unit including critical components

## Performance conditions

The data and results published in this Technology Fact Sheet were obtained from the testing program conducted on the Contech CDS-4 OGS device, in accordance with the Procedure for Laboratory Testing of Oil-Grit Separators (Version 3.0, June 2014). The Procedure was prepared by the Toronto and Region Conservation Authority (TRCA) for Environment Canada's Environmental Technology Verification (ETV) Program requirements. A copy of the Procedure may be accessed on the Canadian ETV website at [www.etvcanada.ca](http://www.etvcanada.ca).

## Performance claim(s)

### Capture test<sup>1</sup>:

During the sediment capture test, the Contech CDS OGS device with a false floor set to 50% of the manufacturer's recommended maximum sediment storage depth and a constant influent test sediment concentration of 200 mg/L, removed 74, 70, 63, 53, 45, 42, 32 and 23 percent of influent sediment by mass at surface loading rates of 40, 80, 200, 400, 600, 1000, 1400 and 1893 L/min/m<sup>2</sup>, respectively.

### Scour test<sup>2</sup>:

During the scour test, the Contech CDS OGS device with preloaded test sediment reaching 50% of the manufacturer's recommended maximum sediment storage depth, generated corrected effluent concentrations of 1.8, 6.5, 8.2, 11.2, and 309.3 mg/L during a test run<sup>2</sup> with approximately 5 minute duration surface loading rates of 200, 800, 1400, 2000, and 2600 L/min/m<sup>2</sup>, respectively.

### Light liquid re-entrainment test<sup>2</sup>:

During the light liquid re-entrainment test, the Contech CDS OGS device with surrogate low-density polyethylene beads preloaded within the oil collection skirt area, representing floating liquid to a volume equal to a depth of 50.8 mm over the sedimentation area, retained 100, 99.9, 98.6, 99.5, and 99.7 percent of loaded beads by volume during a test run<sup>2</sup> with 5 minutes duration surface loading rates of 200, 800, 1400, 2000, and 2600 L/min/m<sup>2</sup>, respectively.

## Performance results

The test sediment consisted of ground silica (1 – 1000 micron) with a specific gravity of 2.65, uniformly mixed to meet the particle size distribution specified in the testing procedure. The *Procedure for Laboratory Testing of Oil Grit Separators* requires that the three sample average of the test sediment particle size distribution (PSD) meet the specified PSD percent less than values within a boundary threshold of 6%. The comparison of the average test sediment PSD to the CETV specified PSD in Figure 2 indicates that the test sediment used for the capture and scour tests met this condition.

---

<sup>1</sup> The claim can be applied to other units smaller or larger than the tested unit as long as the untested units meet the scaling rule specified in the Procedure for Laboratory of Testing of Oil Grit Separators (Version 3.0, June 2014)

<sup>2</sup> See variance #1 in "Variances from testing procedure" section below.

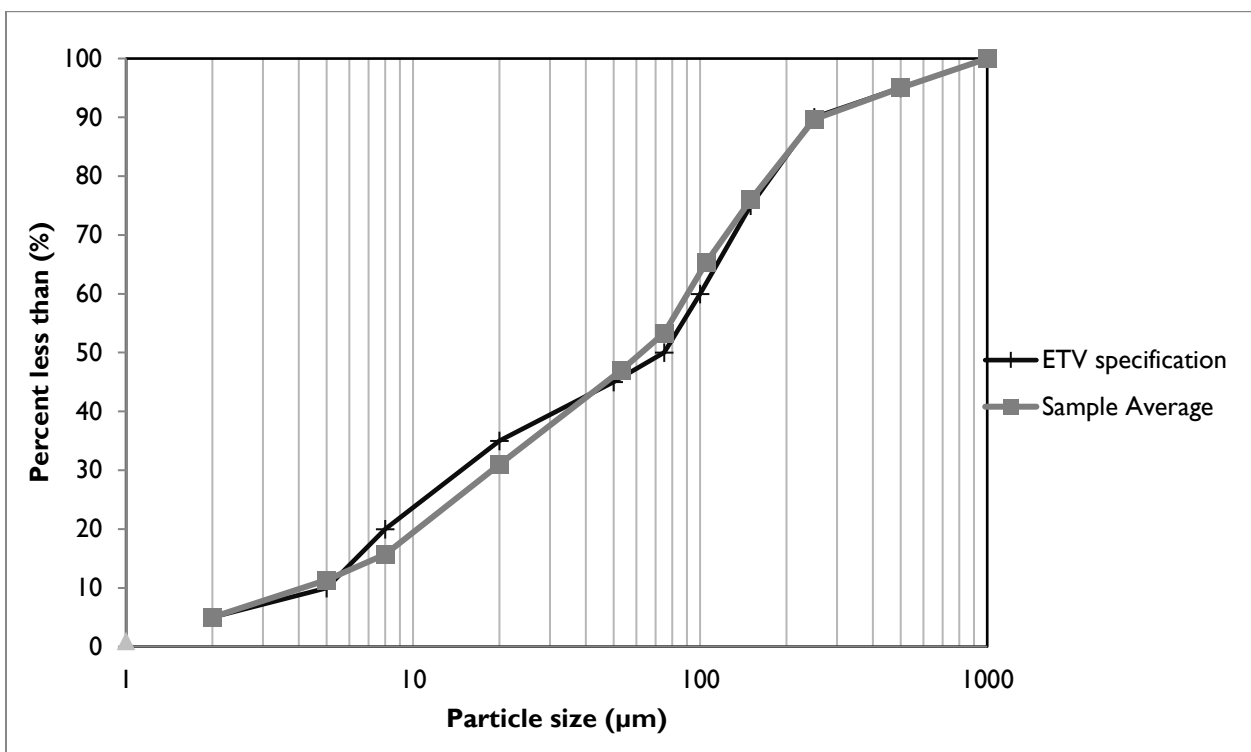

Figure 2. The three sample average particle size distribution (PSD) of the test sediment used for the capture and scour test compared to the specified PSD.

The capacity of the device to retain sediment was determined at eight surface loading rates using the modified mass balance method. This method involved measuring the mass and particle size distribution of the injected and retained sediment for each test run. Performance was evaluated with a false floor simulating the technology filled to 50% of the manufacturer’s recommended maximum sediment storage depth. The test was carried out with clean water that maintained a sediment concentration below 20 mg/L. Based on these conditions, removal efficiencies for individual particle size classes and for the test sediment as a whole were determined for each of the tested surface loading rates (Table I).

In some instances, the calculated removal efficiencies were above 100% for certain particle size fractions (marked with asterisks in Table I). These discrepancies are not entirely avoidable and may be attributed to errors relating to the blending of sediment, collection of representative samples, and laboratory analysis of PSD. Due to these errors, caution should be exercised in applying the removal efficiencies by particle size fraction for the purposes of sizing the tested device (see [Bulletin # CETV 2016-11-0001](#)). The results for “all particle sizes by mass balance” in Table I are based on measurements of the total injected and retained sediment mass, and are therefore not subject to sampling or PSD analysis errors.

Table I. Removal efficiencies (%) at specified surface loading rates.

Particle size fraction (µm)	Surface loading rate (L/min/m <sup>2</sup> )							
	40	80	200	400	600	1000	1400	1893
>500	100	100*	66	79	97	100*	84	77
250 - 500	100*	100*	85	95	100*	91	100*	75
150 - 250	99	100*	100*	97	100	75	68	37
105 - 150	100	100*	100*	74	47	45	30	27
75 - 105	90	91	100*	61	33	36	26	18
53 - 75	71	27	54	100	42	44	15	16
20 - 53	65	51	20	8	10	8	5	4
8 - 20	28	22	9	7	1	1	2	1
5 - 8	30	9	0	8	2	0	1	0
<5	11	8	16	2	6	5	2	2
<b>All particle sizes by mass balance</b>	<b>73.5</b>	<b>70.3</b>	<b>63.4</b>	<b>52.6</b>	<b>45.1</b>	<b>41.5</b>	<b>32.4</b>	<b>23.0</b>

\* Removal efficiencies were calculated to be above 100%. Calculated values typically ranged between 101 and 175% (average 126%). Higher values were observed for the >500 µm and 150-250 µm size fractions during the 80 L/min/m<sup>2</sup> test run. See text and [Bulletin # CETV 2016-11-0001](#) for more information.

Figure 3 compares the particle size distribution (PSD) of the three sample average of the test sediment to the PSD of the retained sediment at each of the tested surface loading rates. As expected, the capture efficiency for fine particles was generally found to decrease as surface loading rates increased.

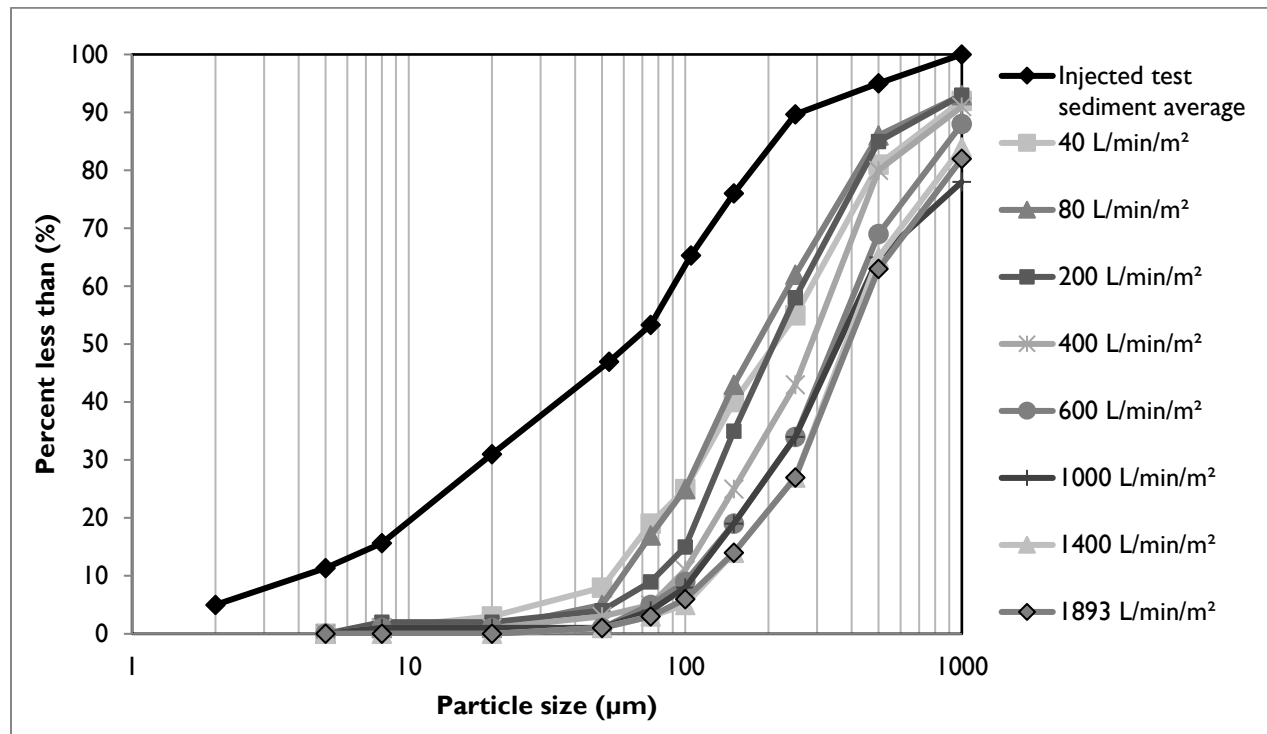

Figure 3. Particle size distribution of retained sediment in relation to the injected test sediment average.

Table 2 shows the results of the sediment scour and re-suspension test. This test involved preloading 10.2 cm of fresh test sediment into the sedimentation sump of the device. The sediment was placed on a false floor to mimic a device filled to 50% of the maximum recommended sediment storage depth. Sediment was also pre-loaded to the same depth on the separation slab (see Figure 1) since sediment was observed to have been deposited in this area during the sediment capture test. Clean water was run through the device at five surface loading rates over a 36 minute period. The test was stopped and started after the second flow rate in order to change flow meters. Each flow rate was maintained for 5 minutes with a one minute transition time between flow rates. Effluent samples were collected at one minute sampling intervals and analyzed for Suspended Sediment Concentration (SSC) and PSD by recognized methods. The effluent samples were subsequently adjusted based on the background concentration of the influent water and the smallest 5% of particles captured during the 40 L/min/m<sup>2</sup> sediment capture test, as per the method described in [Bulletin # CETV 2016-09-0001](#).

Table 2. Scour test adjusted effluent sediment concentration.

Run	Surface loading rate (L/min/m <sup>2</sup> )	Run time (min)	Background sample concentration (mg/L)	Adjusted effluent suspended sediment concentration (mg/L) <sup>†</sup>	Average (mg/L)
1	200	1.03	0.5	1.0	1.8
		2.03		1.6	
		3.03		1.8	
		4.03		1.8	
		5.03		2.6	
2	800	6.23	2.0	5.0	6.5
		7.23		6.7	
		8.23		9.4	
		9.23		5.4	
		10.23		5.9	
3	1400	11.43 <sup>‡</sup>	2.0	3.1	8.2
		12.43		11.0	
		13.43		14.6	
		14.43		7.1	
		15.43		5.2	
4	2000	17.20	3.2	7.3	11.2
		18.20		22.8	
		19.20		6.9	
		20.20		6.8	
		21.20		12.1	
5	2600	22.40	8.5	248.5	309.3
		23.40		83.0	
		24.40		438.9	
		25.40		338.7	
		26.40		437.5	

<sup>†</sup> The adjusted effluent suspended sediment concentration represents the actual measured effluent concentration minus the smallest 5% of sediment particles (i.e. d<sub>5</sub>) removed during the 40 L/min/m<sup>2</sup> capture test, minus the background concentration. For more information see [Bulletin # CETV 2016-09-0001](#).

<sup>‡</sup> See variance #1 in "Variances from testing procedure" section below.

The results of the light liquid re-entrainment test used to evaluate the unit’s capacity to prevent re-entrainment of light liquids are reported in Table 3. The test involved preloading 58.3 L (corresponding to a 5 cm depth over the collection sump area of 1.17m<sup>2</sup>) of surrogate low-density polyethylene beads within the oil collection skirt and running clean water through the device at five surface loading rates (200, 800, 1400, 2000, and 2600 L/min/m<sup>2</sup>) over a 38 minute period. As with the sediment scour test, flow was stopped and started after the second flow rate to change flow meters. Each flow rate was maintained for 5 minutes with approximately 1 minute transition time between flow rates. The effluent flow was screened to capture all re-entrained pellets throughout the test.

Table 3. Light liquid re-entrainment test results.

Target Flow (L/min/m <sup>2</sup> )	Time Stamp	Collected Volume (L)	Collected Mass (g)	Percent re-entrained by volume	Percent retained by volume
200	10:48:42	27 pellets	0.8	0.01	99.99
800	10:55:09	0.07	41	0.12	99.88
1400	11:06:59	0.8	439	1.37	98.63
2000	11:13:00	0.31	177	0.53	99.47
2600	11:19:00	0.18	98	0.31	99.69
Interim Collection Net		0.025	14.2	0.04	99.96
Total Loaded		58.3	33398	--	--
Total Re-entrained		1.385	770	--	--
Percent Re-entrained and retained		--	--	2.38	97.62

## Variations from testing Procedure

The following minor deviations from the *Procedure for Laboratory Testing of Oil-Grit Separators* (Version 3.0, June 2014) have been noted:

1. It was necessary to change flow meters during the scour and light liquid re-entrainment test, as the required flows exceeded the minimum and/or maximum range of any single meter. After the loading rate of 800 L/min/m<sup>2</sup>, the flow was gradually shut down and re-initiated through the larger meter immediately after closing the valve controlling flows to the small meter. The transition time of 1-minute for each target flow was followed, resulting in an elapsed time of 3 minutes to reach the next target flow of 1400 L/min/m<sup>2</sup>. This procedure was approved by CETV prior to testing, in recognition that most particles susceptible to scour at low flows would not be in the sump at higher flows. Similarly, re-entrainment of the oil beads was not expected to be significantly affected by the flow meter change.
2. As part of the capture test, evaluation of the 40 L/min/m<sup>2</sup> surface loading rate was split into 3 parts due to the long duration needed to feed the required minimum of 11.3 kg of test sediment into the unit. At the end of the first and second parts of the test, the flow rates were gradually shutdown to prevent capture of particles that would have been washed out under normal circumstances. The amended procedure was reviewed and approved by the verifier prior to testing.
3. Inflow concentrations during the 40 L/min/m<sup>2</sup> surface loading rate varied from 162 mg/L to 246 mg/L, which is wider than specified ±25 mg/L range in the Procedure.

## Verification

This verification was first completed in March 2017 and is considered valid for subsequent renewal periods every three (3) years thereafter, subject to review and confirmation of the original performance and performance claims. The original verification was completed by the Toronto and Region Conservation Authority of Mississauga, Ontario, Canada using the Canadian ETV Program's General Verification Protocol (June 2012) and taking into account ISO 14034:2016. This ETV renewal is considered to meet the equivalency of an ETV verification completed using the International Standard *ISO 14034:2016 Environmental management – Environmental technology verification (ETV)*.

Data and information provided by Contech Engineered Solutions to support the performance claim included the following: Performance test report prepared by Alden Research Laboratory, Inc of Holden, Massachusetts, USA and dated February 2015; the report is based on testing completed in accordance with the Procedure for Laboratory Testing of Oil-Grit Separators (Version 3.0, June 2014).

## What is ISO 14034:2016 Environmental management – Environmental technology verification (ETV)?

ISO 14034:2016 specifies principles, procedures and requirements for environmental technology verification (ETV) and was developed and published by the International Organization for Standardization (ISO). The objective of ETV is to provide credible, reliable and independent verification of the performance of environmental technologies. An environmental technology is a technology that either results in an environmental added value or measures parameters that indicate an environmental impact. Such technologies have an increasingly important role in addressing environmental challenges and achieving sustainable development.

**For more information on the CDS Stormwater Treatment System please contact:**

CONTECH Engineered Solutions LLC  
71 US Route 1, Suite F  
Scarborough, ME  
04074 USA  
Tel: 207-885-9830  
info@conteches.com  
www.conteches.com

**For more information on ISO 14034:2016 / ETV please contact:**

GLOBE Performance Solutions  
404 – 999 Canada Place  
Vancouver, BC  
V6C 3E2 Canada  
Tel: 604-695-5018 / Toll Free: 1-855-695-5018  
etv@globepformance.com  
www.globepformance.com

### **Limitation of verification - Registration: GPS-ETV\_VR2020-03-31\_CDS**

GLOBE Performance Solutions and the Verification Expert provide the verification services solely on the basis of the information supplied by the applicant or vendor and assume no liability thereafter. The responsibility for the information supplied remains solely with the applicant or vendor and the liability for the purchase, installation, and operation (whether consequential or otherwise) is not transferred to any other party as a result of the verification.



## CDS Average Annual Efficiency For TSS Removal

**Area =** 4.01 ha  
**C =** 0.82  
**CDS Model:** CDS PMSU2015\_5  
**Flowrate:** 20  
**IDF Data:** Ottawa

**Engineer:** D.B. Gray Engineering Inc.  
**Contact:** Laurent Brosseau  
**Date:** 7/Feb/25  
  
**Project:** 151-159 Wescar Ln.  
**Location:** Ottawa, ON  
**OGS ID:** OGS

Return	Period	Flow	TSS Percentage Captured	Treated Flow Volume	Total Flow Volume	Frequency of Occurrence	System Flow	CDS Flow	By-Pass Flow	Volume Percentage Treated
month / yr	Yr	l/s	%	litres	litres	%	l/s	l/s	l/s	%
1m	0.08	4.30	94.7	4599	4599	91.70	4.30	4	0.00	100.00
2m	0.17	7.10	92.1	7584	7584	83.33	7.10	7	0.00	100.00
3m	0.25	9.45	89.8	10101	10101	75.00	9.45	9	0.00	100.00
4m	0.33	11.62	87.7	12414	12414	66.70	11.62	12	0.00	100.00
5m	0.42	13.47	86.1	14228	14228	58.30	13.47	13	0.00	100.00
6m	0.50	15.01	84.5	16042	16042	50.00	15.01	15	0.00	100.00
7m	0.58	16.44	83.2	17426	17426	41.70	16.44	16	0.00	100.00
8m	0.67	17.75	82.0	18810	18810	33.30	17.75	18	0.00	100.00
9m	0.75	18.90	80.7	20194	20194	25.00	18.90	19	0.00	100.00
10m	0.83	20.00	79.5	21142	21303	16.70	20.00	20	0.00	99.32
11m	0.92	21.04	78.2	22091	22411	8.30	21.04	20	0.94	98.64
1y	1	22.01	77.0	23039	23520	1.00	22.01	20	1.91	97.96
2y	2	30.82	64.6	27714	32932	0.50	30.82	20	10.72	84.16
5y	5	36.25	58.6	29748	38734	0.20	36.25	20	16.15	76.80
10y	10	41.30	54.1	31428	44130	0.10	41.30	20	21.20	71.22
25y	25	45.40	51.0	32631	48510	0.04	45.40	20	25.30	67.27
50y	50	52.20	46.5	34368	55776	0.02	52.20	20	32.10	61.62
100y	100	55.39	44.7	35092	59185	0.01	55.39	20	35.29	59.29
<b>Q-ave</b>		<b>14.76</b> l/s		378653.1	467899.2					

**Average Annual TSS Removal Efficiency [%]: 85**      **Ave. Ann. T. Volume [%]: 99**

\\FILESERVER-ND\IPUBLIC\SHARE\4.0 MANUFACTURERS\CONTECH PRODUCT INFO\TREATMENT\CDS\DRAWINGS ECHOLON\IN LINE-PDF\2022 - PMSU UPDATED CONTECH DRAWINGS - HUDA\15\CDS\2015-5-C-DTL.DWG - 1/27/2025 9:24 AM

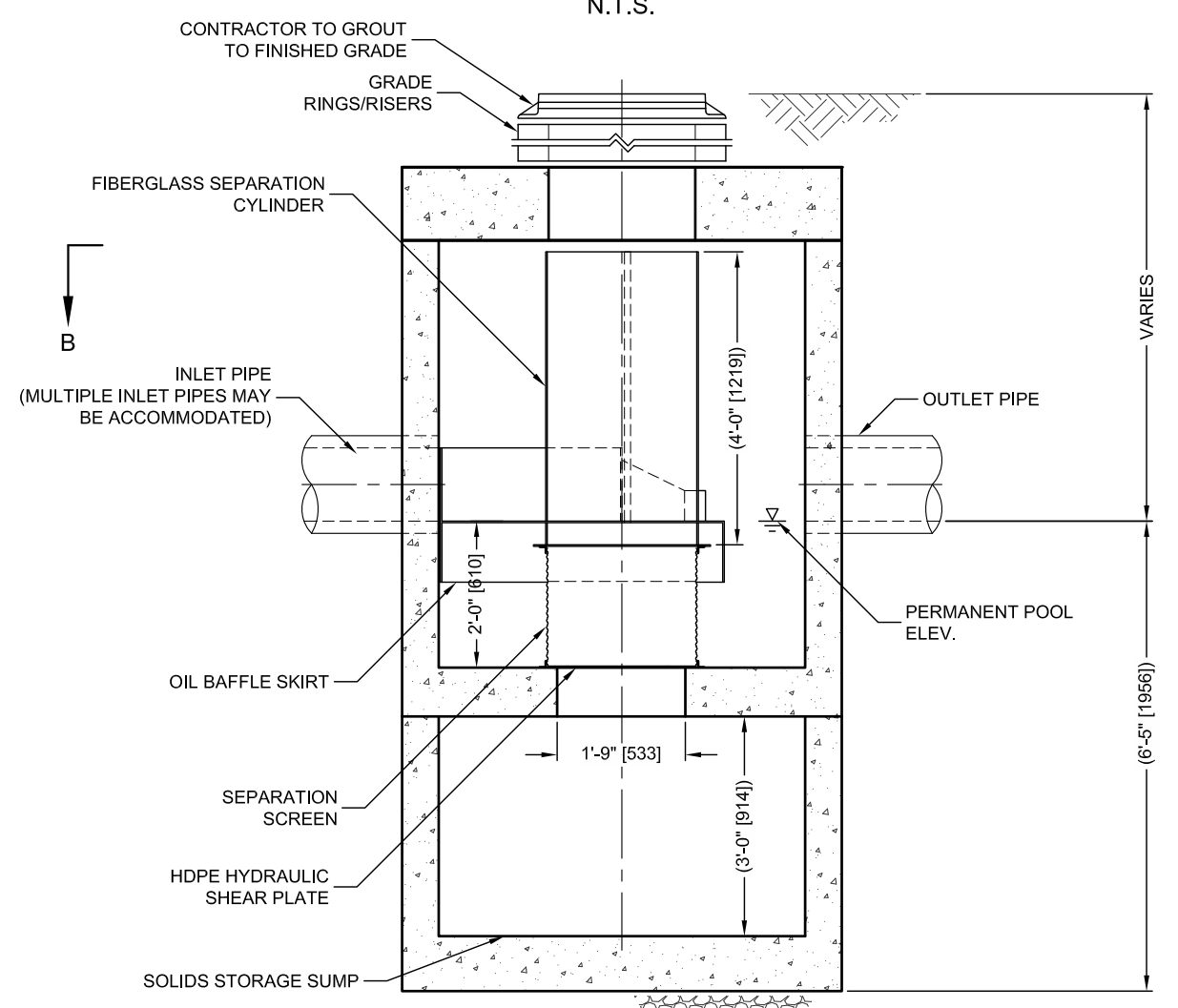
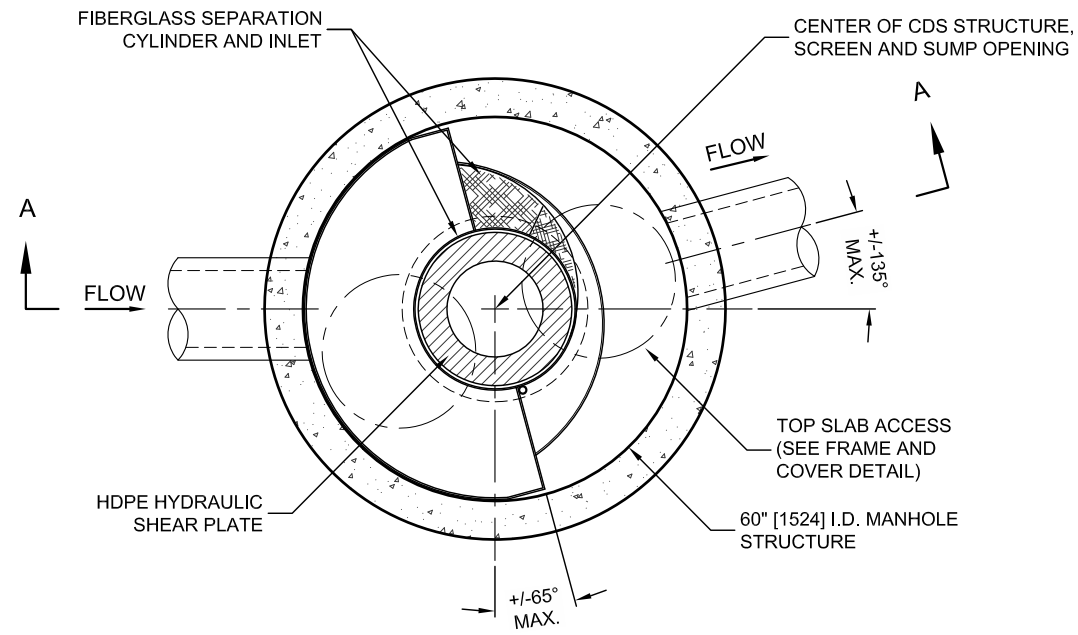

CDS PMSU2015-5-C DESIGN NOTES	
CDS PMSU2015-5-C RATED TREATMENT CAPACITY IS 0.7 CFS [19.8 L/s], OR PER LOCAL REGULATIONS. MAXIMUM HYDRAULIC INTERNAL BYPASS CAPACITY IS 10.0 CFS [396 L/s]. IF THE SITE CONDITIONS EXCEED 14.0 [396 L/s] CFS, AN UPSTREAM BYPASS STRUCTURE IS REQUIRED.	
THE STANDARD CDS PMSU2015-5-C CONFIGURATION IS SHOWN. ALTERNATE CONFIGURATIONS ARE AVAILABLE AND ARE LISTED BELOW. SOME CONFIGURATIONS MAY BE COMBINED TO SUIT SITE REQUIREMENTS.	
CONFIGURATION DESCRIPTION	
GRATED INLET ONLY (NO INLET PIPE)	
GRATED INLET WITH INLET PIPE OR PIPES	
CURB INLET ONLY (NO INLET PIPE)	
CURB INLET WITH INLET PIPE OR PIPES	

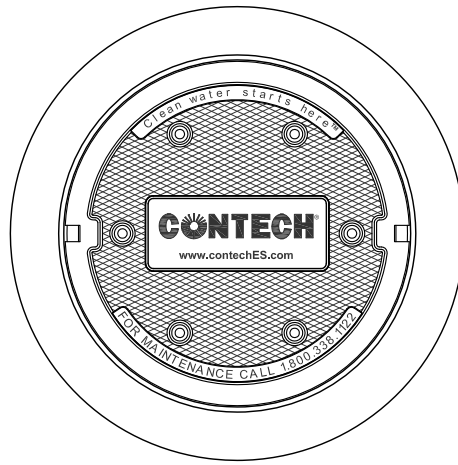

SITE SPECIFIC DATA REQUIREMENTS			
STRUCTURE ID			
WATER QUALITY FLOW RATE (CFS OR L/s)		*	
PEAK FLOW RATE (CFS OR L/s)		*	
RETURN PERIOD OF PEAK FLOW (YRS)		*	
SCREEN APERTURE (2400 OR 4700)		*	
PIPE DATA:	I.E.	MATERIAL	DIAMETER
INLET PIPE 1	*	*	*
INLET PIPE 2	*	*	*
OUTLET PIPE	*	*	*
RIM ELEVATION		*	
ANTI-FLOTATION BALLAST	WIDTH	HEIGHT	
	*	*	
NOTES/SPECIAL REQUIREMENTS:			
* PER ENGINEER OF RECORD			

- GENERAL NOTES**
- CONTECH TO PROVIDE ALL MATERIALS UNLESS NOTED OTHERWISE.
  - DIMENSIONS MARKED WITH ( ) ARE REFERENCE DIMENSIONS. ACTUAL DIMENSIONS MAY VARY.
  - FOR FABRICATION DRAWINGS WITH DETAILED STRUCTURE DIMENSIONS AND WEIGHTS, PLEASE CONTACT YOUR CONTECH CONSTRUCTION PRODUCTS REPRESENTATIVE. [www.contech-cpi.com](http://www.contech-cpi.com)
  - CDS WATER QUALITY STRUCTURE SHALL BE IN ACCORDANCE WITH ALL DESIGN DATA AND INFORMATION CONTAINED IN THIS DRAWING.
  - STRUCTURE SHALL MEET AASHTO HS20 AND CASTINGS SHALL MEET HS20 (AASHTO M 306) LOAD RATING, ASSUMING GROUNDWATER ELEVATION AT, OR BELOW, THE OUTLET PIPE INVERT ELEVATION. ENGINEER OF RECORD TO CONFIRM ACTUAL GROUNDWATER ELEVATION.
  - PVC HYDRAULIC SHEAR PLATE IS PLACED ON SHELF AT BOTTOM OF SCREEN CYLINDER. REMOVE AND REPLACE AS NECESSARY DURING MAINTENANCE CLEANING.
  - MANHOLE MANUFACTURED TO ASTM C478 SPECIFICATION.

- INSTALLATION NOTES**
- ANY SUB-BASE, BACKFILL DEPTH, AND/OR ANTI-FLOTATION PROVISIONS ARE SITE-SPECIFIC DESIGN CONSIDERATIONS AND SHALL BE SPECIFIED BY ENGINEER OF RECORD.
  - CONTRACTOR TO PROVIDE EQUIPMENT WITH SUFFICIENT LIFTING AND REACH CAPACITY TO LIFT AND SET THE CDS MANHOLE STRUCTURE (LIFTING CLUTCHES PROVIDED).
  - CONTRACTOR TO ADD JOINT SEALANT BETWEEN ALL STRUCTURE SECTIONS, AND ASSEMBLE STRUCTURE.
  - CONTRACTOR TO PROVIDE, INSTALL, AND GROUT PIPES. MATCH PIPE INVERTS WITH ELEVATIONS SHOWN.
  - CONTRACTOR TO TAKE APPROPRIATE MEASURES TO ASSURE UNIT IS WATER TIGHT, HOLDING WATER TO FLOWLINE INVERT MINIMUM. IT IS SUGGESTED THAT ALL JOINTS BELOW PIPE INVERTS ARE GROUTED.

**rainwater**  
MANAGEMENT  
Port Coquitlam, B.C.  
604-944-9265 888-966-7246 Fax: 604-676-2601

**GDS**  
THIS PRODUCT MAY BE PROTECTED BY ONE OR MORE OF THE FOLLOWING U.S. PATENTS: 6,788,848; 6,841,722; 6,911,502; 6,981,783; RELATED FOREIGN PATENTS, OR OTHER PATENTS FROM TIME TO TIME.

**CONTECH**  
CONSTRUCTION PRODUCTS INC.  
[www.contech-cpl.com](http://www.contech-cpl.com)  
9025 Centre Pointe Dr., Suite 400, West Chester, OH 45069  
800-338-1122 513-645-7000 513-645-7993 FAX

CDS PMSU2015-5-C  
INLINE CDS  
STANDARD DETAIL

# BOREHOLE BH-STORM

**PROJECT:**Proposed Industrial Development  
**CLIENT:**Sunbelt Rentals Inc  
**LOCATION:**151 - 159 Wescar Lane  
**PENETRATION TEST HAMMER:**

**PROJECT NUMBER:**230403  
**DATE OF BORING:** 2023-05-30  
**SHEET:**1 of 1  
**DATUM:**GEODETIC

DEPTH SCALE (meters)	SOIL PROFILE				SAMPLES			UNDIST SHEAR STRENGTH					DYNAMIC CONE PENETRATION TEST					MOISTURE CONTENT (%)	PIEZOMETER OR STANDPIPE INSTALLATION	
	DESCRIPTION	DEPTH (m)	STRATA PLOT	ELEV. (m)	NUMBER	TYPE	BLOWS/0.3m	x Cu. kPa x					blows/300 mm							
								o Cu. kPa o												
0.00 0.15	Red brown fine to medium sand (FILL) Grey brown fine to medium sand (FILL)		X		1	SS	5													
1.0	Grey brown sand and gravel (FILL)	1.07	X		2	SS	8													
2.0	Grey brown CLAYEY SILT, trace sand	1.52			3	SS	7													
3.0					4	SS	7													
	End of borehole in SILT	3.05																		

▽

Some groundwater observed at about 1.1 metres below the existing ground surface, May 30, 2023.

**DEPTH SCALE:** 1 to 50 **LOGGED:** CI  
**BORING METHOD:** Power Auger **CHECKED:** SD  
**AUGER TYPE:** 200 mm Hollow Stem

# Unified Soil Classification System

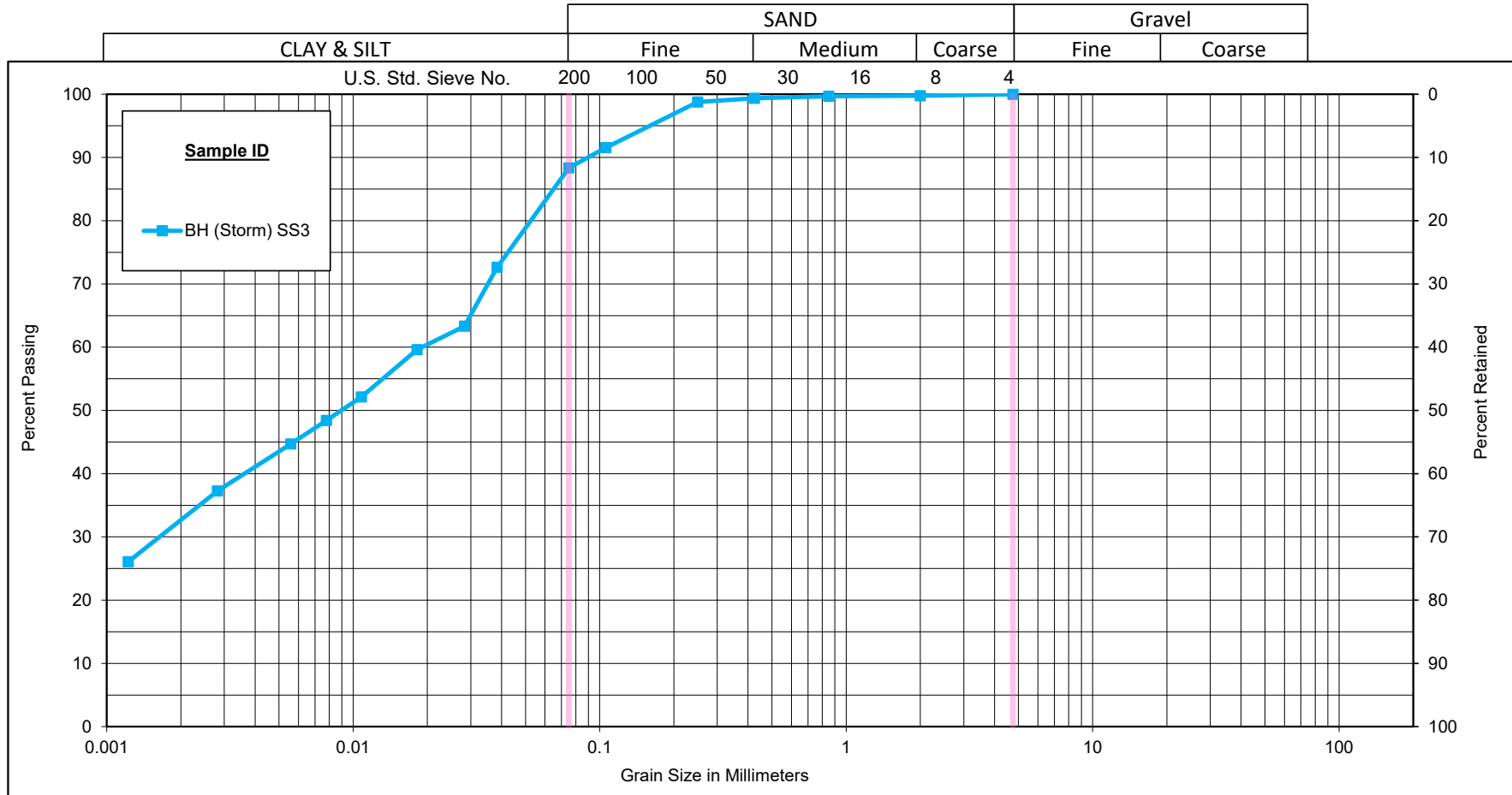

Sample ID	Depth	% Gravel	% Sand	% Silt	% Clay
BH (Storm) SS3	5'-7'	0.0	11.6	56.4	32.0



## GRAIN SIZE DISTRIBUTION

Kollaard Associates, File #230403  
151-159 Wescar Lane

Figure No.

Project No. 122410003



# Particle-Size Analysis of Soils

LS702

AASHTO T88

PROJECT DETAILS			
Client:	Kollaard Associates, File #230403	Project No.:	122410003
Project:	151-159 Wescar Lane	Test Method:	LS702
Material Type:	Soil	Sampled By:	Kollaard Associates
Source:	BH (Storm)	Date Sampled:	June 13, 2023
Sample No.:	SS3	Tested By:	Daniel Boateng
Sample Depth:	5'-7'	Date Tested:	June 18, 2023

WASH TEST DATA	
Oven Dry Mass In Hydrometer Analysis (g)	52.41
Sample Weight after Hydrometer and Wash (g)	6.14
Percent Passing No. 200 Sieve (%)	88.3
Percent Passing Corrected (%)	88.08

PERCENT LOSS IN SIEVE	
Sample Weight Before Sieve (g)	217.30
Sample Weight After Sieve (g)	216.50
Percent Loss in Sieve (%)	0.37

SOIL INFORMATION		
Liquid Limit (LL)		
Plasticity Index (PI)		
Soil Classification		
Specific Gravity (G <sub>s</sub> )	2.750	
Sg. Correction Factor (α)	0.978	
Mass of Dispersing Agent/Litre	40	g

CALCULATION OF DRY SOIL MASS	
Oven Dried Mass (W <sub>o</sub> ), (g)	160.14
Air Dried Mass (W <sub>a</sub> ), (g)	162.79
Hygroscopic Corr. Factor (F=W <sub>o</sub> /W <sub>a</sub> )	0.9837
Air Dried Mass in Analysis (M <sub>a</sub> ), (g)	53.28
Oven Dried Mass in Analysis (M <sub>o</sub> ), (g)	52.41
Percent Passing 2.0 mm Sieve (P <sub>10</sub> ), (%)	99.77
Sample Represented (W), (g)	52.53

SIEVE ANALYSIS		
Sieve Size mm	Cum. Wt. Retained	Percent Passing
75.0		100.0
63.0		100.0
53.0		100.0
37.5		100.0
26.5		100.0
19.0		100.0
13.2		100.0
9.5		100.0
4.75	0.0	100.0
2.00	0.5	99.8
<b>Total (C + F)<sup>1</sup></b>	<b>216.50</b>	
0.850	0.05	99.67
0.425	0.22	99.35
0.250	0.52	98.78
0.106	4.31	91.57
0.075	5.99	88.37
PAN	6.08	

Note 1: (C + F) = Coarse + Fine

HYDROMETER DETAILS	
Volume of Bulb (V <sub>B</sub> ), (cm <sup>3</sup> )	63.0
Length of Bulb (L <sub>2</sub> ), (cm)	14.47
Length from '0' Reading to Top of Bulb (L <sub>1</sub> ), (cm)	10.29
Scale Dimension (h <sub>s</sub> ), (cm/Div)	0.155
Cross-Sectional Area of Cylinder (A), (cm <sup>2</sup> )	27.25
Meniscus Correction (H <sub>m</sub> ), (g/L)	1.0

START TIME 9:01 AM

HYDROMETER ANALYSIS											
Date	Time	Elapsed Time T Mins	H <sub>s</sub> Divisions g/L	H <sub>c</sub> Divisions g/L	Temperature T <sub>c</sub> °C	Corrected Reading R = H <sub>s</sub> - H <sub>c</sub> g/L	Percent Passing P %	L cm	η Poise	K	Diameter D mm
18-Jun-23	9:02 AM	1	46.0	7.0	23.5	39.0	72.63	9.08404	9.28431	0.012744	0.03841
18-Jun-23	9:03 AM	2	41.0	7.0	23.5	34.0	63.32	9.85904	9.28431	0.012744	0.02830
18-Jun-23	9:06 AM	5	39.0	7.0	23.5	32.0	59.60	10.16904	9.28431	0.012744	0.01817
18-Jun-23	9:16 AM	15	35.0	7.0	23.5	28.0	52.15	10.78904	9.28431	0.012744	0.01081
18-Jun-23	9:31 AM	30	33.0	7.0	23.0	26.0	48.42	11.09904	9.39251	0.012818	0.00780
18-Jun-23	10:01 AM	60	31.0	7.0	23.0	24.0	44.70	11.40904	9.39251	0.012818	0.00559
18-Jun-23	1:11 PM	250	27.0	7.0	23.0	20.0	37.2475	12.02904	9.39251	0.012818	0.00281
19-Jun-23	9:01 AM	1440	21.0	7.0	22.5	14.0	26.0732	12.95904	9.50295	0.012894	0.00122

Remarks:

Reviewed By: *Daniel Boateng*  
Date: June 21, 2023



December 4, 2023

230403

Sunbelt Rentals Inc.  
2849 Sheffield Road  
Ottawa, Ontario  
K1B 3V6

## TECHNICAL MEMORANDUM – INSITU INFILTRATION RATE

**Re: RESPONSE TO CITY OF OTTAWA'S REVIEW FEEDBACK  
DATED OCTOBER 24, 2023 - ENGINEERING COMMENTS  
PROPOSED SITE PLAN CONTROL  
151-159 WESCAR LANE, STITTSVILLE  
OTTAWA, ONTARIO**

This memo provides our response to the City of Ottawa's review comment (below) regarding the geotechnical report dated June 14, 2023 by Kollaard Associates Inc., Project 230403, for the proposed commercial development at 151-159 Wescar Lane, Stittsville, City of Ottawa, Ontario. The comments were addressed to Mr. Keith Riley of Argue Construction and were subsequently forwarded to Kollaard Associates Inc.

- ***The report should include permeability testing of the soils within the area where the Infiltration trench will be located***

Kollaard Associates Inc returned to the site on November 28 and 30, 2023 to complete two in-situ hydraulic conductivity assessments within the foot print of the proposed stormwater management infiltration trench (see Site Plan, Figure 1). The subsurface conditions consisted of about 1.5 metres of fill materials (fine to medium sand or sand and gravel) overlying clayey silt with a trace of sand.

Two in-situ hydraulic conductivity tests were completed using a Guelph Permeameter within the area of the proposed storm infiltration area in the existing materials within 1.0 metres of the underside of the proposed infiltration trench. The existing soils at this level were described as red brown fine to medium sand fill. The results of the testing and associated calculations are included as Appendix A following this report.

The results of the calculations based on the in-situ hydraulic conductivity tests gave a coefficient of permeability of between  $1.0 \times 10^{-4}$  and  $2.7 \times 10^{-5}$  cm/s.

The following table obtained from the Low Impact Development Stormwater Management Planning and Design Guide - Appendix C produced by Credit Valley Conservation and Toronto and Region Conservation indicates the relationship between the Percolation Time, Coefficient of Permeability and Infiltration Rate.





**Table C1: Approximate relationships between hydraulic conductivity, percolation time and infiltration rate**

Hydraulic Conductivity, $K_{fs}$ (centimetres/second)	Percolation Time, T (minutes/centimetre)	Infiltration Rate, 1/T (millimetres/hour)
0.1	2	300
0.01	4	150
0.001	8	75
0.0001	12	50
0.00001	20	30
0.000001	50	12

Source: Ontario Ministry of Municipal Affairs and Housing (OMMAH). 1997. Supplementary Guidelines to the Ontario Building Code 1997. SG-6 Percolation Time and Soil Descriptions. Toronto, Ontario.

From the above comparison, the existing soils within 1 metre of the bottom of the infiltration trenches would have an estimated infiltration rate of 30 to 50 millimetres/hour.

We trust that this report provides sufficient information for your present purposes. If you have any questions concerning this information or if we can be of further assistance to you, please do not hesitate to contact our office.

Yours truly,  
Kollaard Associates Inc.

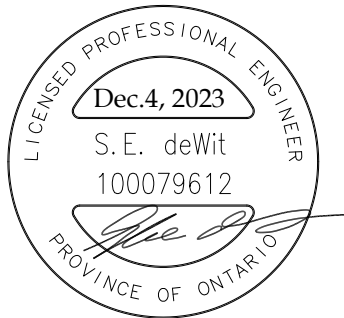

Steve deWit, P.Eng.

# Guelph Permeameter Test

Location 151 - 159 Wescar Lane

Date: 2023-11-28

Investigator CI

Depth of Hole (cm) 25 Hole Diameter (cm) 6

Reservoir Used During Test (Select One) Combined (X)

Reservoir Constant Used 35.31

---

## Single/First Head Test

---

Water Level in Well (cm) 15

[t] Time (mins.)	$\Delta t$ (mins.)	Water Level in Reservoir (cm)	$\Delta h$ (cm)	Rate of change $\Delta h/\Delta t$ (cm/min)
0		5.5		
2	2	5.7	0.2	0.1
4	2	6	0.3	0.15
6	2	6.2	0.2	0.1
8.5	2.5	6.6	0.4	0.16
10.5	2	6.8	0.2	0.1
12.5	2	7	0.2	0.1
14.5	2	7.2	0.2	0.1



# Guelph Permeameter Test

Location 151 - 159 Wescar Lane

Date: 2023-11-30

Investigator Isaac Bacon

Depth of Hole (cm) 28 Hole Diameter (cm) 6

Reservoir Used During Test (Select One) Combined (X)

Reservoir Constant Used 35.31

---

## Single/First Head Test

---

Water Level in Well (cm) 20

[t] Time (mins.)	$\Delta t$ (mins.)	Water Level in Reservoir (cm)	$\Delta h$ (cm)	Rate of change $\Delta h/\Delta t$ (cm/min)
0		5.5		
1	1	6.3	0.8	0.8
2	1	6.8	0.5	0.5
3	1	7.5	0.7	0.7
4	1	8.2	0.7	0.7
5	1	8.8	0.6	0.6
6	1	9.3	0.5	0.5
7	1	10	0.7	0.7
8	1	10.6	0.6	0.6
9	1	11.2	0.6	0.6
10	1	11.7	0.5	0.5
11	1	12.3	0.6	0.6
12	1	13.0	0.7	0.7
13	1	13.5	0.5	0.5
14	1	14.1	0.6	0.6
15	1	14.7	0.6	0.6
16	1	15.3	0.6	0.6
17	1	15.8	0.5	0.5
18	1	16.3	0.5	0.5
19	1	16.8	0.5	0.5
20	1	17.3	0.5	0.5

# Guelph Permeameter Calculations

Input  
Result

## Single Head Method - Nov 28, 2023

Reservoir Cross-sectional area in cm<sup>2</sup>  
(enter "35.22" for Combined and "2.16" for Inner reservoir): 35.22

Enter water Head Height ("H" in cm): 15

Enter the Borehole Radius ("a" in cm): 6

Enter the soil texture-structure category (enter one of the below numbers): 3

1. Compacted, Structure-less, clayey or silty materials such as landfill caps and liners, lacustrine or marine sediments, etc.
2. Soils which are both fine textured (clayey or silty) and unstructured; may also include some fine sands.
3. Most structured soils from clays through loams; also includes unstructured medium and fine sands. The category most frequently applicable for agricultural soils.
4. Coarse and gravely sands; may also include some highly structured soils with large and/or numerous cracks, macropores, etc

Steady State Rate of Water Level Change ("R" in cm/min): 0.1000

Res Type: 35.22 \* "R" = three values in a row with matching Δh/Δt

H	15	α*	<span style="background-color: #FFD700; border: 1px solid black; padding: 2px;">0.12</span> cm <sup>-1</sup>
a	6	C	<span style="background-color: #FFD700; border: 1px solid black; padding: 2px;">1.062625</span>
H/a	2.5	Q	<span style="background-color: #FFD700; border: 1px solid black; padding: 2px;">0.0587</span>
a*	0.12	K <sub>fs</sub>	<span style="background-color: #FFD700; border: 1px solid black; padding: 2px;">2.69E-05</span> cm/sec
CO.01	1.033		<span style="background-color: #FFD700; border: 1px solid black; padding: 2px;">1.61E-03</span> cm/min
CO.04	1.085		<span style="background-color: #FFD700; border: 1px solid black; padding: 2px;">2.69E-07</span> m/sec
CO.12	1.063		<span style="background-color: #FFD700; border: 1px solid black; padding: 2px;">6.35E-04</span> inch/min
CO.36	1.063		<span style="background-color: #FFD700; border: 1px solid black; padding: 2px;">1.06E-05</span> inch/sec
C	1.063	Φ <sub>m</sub>	<span style="background-color: #FFD700; border: 1px solid black; padding: 2px;">2.24E-04</span> cm <sup>2</sup> /min
R	0.100		
Q	0.059		
pi	3.142		

## Single Head Method - Nov 30, 2023

Reservoir Cross-sectional area in cm<sup>2</sup>  
(enter "35.22" for Combined and "2.16" for Inner reservoir): 35.22

Enter water Head Height ("H" in cm): 20

Enter the Borehole Radius ("a" in cm): 6

Enter the soil texture-structure category (enter one of the below numbers): 3

1. Compacted, Structure-less, clayey or silty materials such as landfill caps and liners, lacustrine or marine sediments, etc.
2. Soils which are both fine textured (clayey or silty) and unstructured; may also include some fine sands.
3. Most structured soils from clays through loams; also includes unstructured medium and fine sands. The category most frequently applicable for agricultural soils.
4. Coarse and gravely sands; may also include some highly structured soils with large and/or numerous cracks, macropores, etc

Steady State Rate of Water Level Change ("R" in cm/min): 0.5000

Res Type: 35.22 \* "R" = three values in a row with matching Δh/Δt

H	20	α*	<span style="background-color: #FFD700; border: 1px solid black; padding: 2px;">0.12</span> cm <sup>-1</sup>
a	6	C	<span style="background-color: #FFD700; border: 1px solid black; padding: 2px;">1.287543</span>
H/a	3.33333	Q	<span style="background-color: #FFD700; border: 1px solid black; padding: 2px;">0.2935</span>
a*	0.12	K <sub>fs</sub>	<span style="background-color: #FFD700; border: 1px solid black; padding: 2px;">1.02E-04</span> cm/sec
CO.01	1.21841		<span style="background-color: #FFD700; border: 1px solid black; padding: 2px;">6.12E-03</span> cm/min
CO.04	1.29023		<span style="background-color: #FFD700; border: 1px solid black; padding: 2px;">1.02E-06</span> m/sec
CO.12	1.28754		<span style="background-color: #FFD700; border: 1px solid black; padding: 2px;">2.41E-03</span> inch/min
CO.36	1.28754		<span style="background-color: #FFD700; border: 1px solid black; padding: 2px;">4.01E-05</span> inch/sec
C	1.28754	Φ <sub>m</sub>	<span style="background-color: #FFD700; border: 1px solid black; padding: 2px;">8.50E-04</span> cm <sup>2</sup> /min
R	0.500		
Q	0.2935		
pi	3.1415		

## Average

K<sub>fs</sub> = 6.44E-05 cm/sec  
3.87E-03 cm/min  
6.44E-07 m/s  
1.52E-03 inch/min  
2.54E-05 inch/sec

Φ<sub>m</sub> = 5.37E-04 cm<sup>2</sup>/min

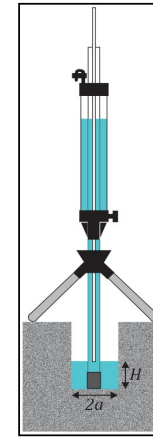

Calculation formulas related to shape factor (C). Where H<sub>1</sub> is the first water head height (cm), H<sub>2</sub> is the second water head height (cm), a is borehole radius (cm) and α\* is microscopic capillary length factor which is decided according to the soil texture-structure category. For one-head method, only C<sub>1</sub> needs to be calculated while for two-head method, C<sub>1</sub> and C<sub>2</sub> are calculated (Zang et al., 1998).

Soil Texture-Structure Category	α*(cm <sup>-1</sup> )	Shape Factor
Compacted, Structure-less, clayey or silty materials such as landfill caps and liners, lacustrine or marine sediments, etc.	0.01	$C_1 = \left( \frac{H_2/a}{2.081 + 0.121(H_2/a)} \right)^{0.672}$
Soils which are both fine textured (clayey or silty) and unstructured; may also include some fine sands.	0.04	$C_1 = \left( \frac{H_2/a}{1.992 + 0.091(H_2/a)} \right)^{0.683}$ $C_2 = \left( \frac{H_2/a}{1.992 + 0.091(H_2/a)} \right)^{0.683}$
Most structured soils from clays through loams; also includes unstructured medium and fine sands. The category most frequently applicable for agricultural soils.	0.12	$C_1 = \left( \frac{H_2/a}{2.074 + 0.093(H_2/a)} \right)^{0.754}$ $C_2 = \left( \frac{H_2/a}{2.074 + 0.093(H_2/a)} \right)^{0.754}$
Coarse and gravely sands; may also include some highly structured soils with large and/or numerous cracks, macro pores, etc.	0.36	$C_1 = \left( \frac{H_2/a}{2.074 + 0.093(H_2/a)} \right)^{0.754}$ $C_2 = \left( \frac{H_2/a}{2.074 + 0.093(H_2/a)} \right)^{0.754}$

Calculation formulas related to one-head and two-head methods. Where R is steady-state rate of fall of water in reservoir (cm/s), K<sub>fs</sub> is Soil saturated hydraulic conductivity (cm/s), Φ<sub>m</sub> is Soil matric flux potential (cm<sup>2</sup>/s), α\* is Macroscopic capillary length parameter (from Table 2), a is Borehole radius (cm), H<sub>1</sub> is the first head of water established in borehole (cm), H<sub>2</sub> is the second head of water established in borehole (cm) and C<sub>1</sub> is Shape factor (from Table 2).

One Head, Combined Reservoir	Q <sub>1</sub> = R̄ <sub>1</sub> × 35.22	$K_{fs} = \frac{C_1 \times Q_1}{2\pi H_1^2 + \pi a^2 C_1 + 2\pi \left( \frac{H_1}{a} \right)}$ $\Phi_m = \frac{C_1 \times Q_1}{(2\pi H_1^2 + \pi a^2 C_1) a^* + 2\pi H_1}$
One Head, Inner Reservoir	Q <sub>1</sub> = R̄ <sub>1</sub> × 2.16	
Two Head, Combined Reservoir	Q <sub>1</sub> = R̄ <sub>1</sub> × 35.22 Q <sub>2</sub> = R̄ <sub>2</sub> × 35.22	$G_1 = \frac{H_2 C_1}{\pi(2H_1 H_2 (H_2 - H_1) + a^2 (H_1 C_2 - H_2 C_1))}$ $G_2 = \frac{H_1 C_2}{\pi(2H_1 H_2 (H_2 - H_1) + a^2 (H_1 C_2 - H_2 C_1))}$ $K_{fs} = G_2 Q_2 - G_1 Q_1$ $G_3 = \frac{(2H_2^2 + a^2 C_2) C_1}{2\pi(2H_1 H_2 (H_2 - H_1) + a^2 (H_1 C_2 - H_2 C_1))}$
Two Head, Inner Reservoir	Q <sub>1</sub> = R̄ <sub>1</sub> × 2.16 Q <sub>2</sub> = R̄ <sub>2</sub> × 2.16	$G_4 = \frac{(2H_1^2 + a^2 C_1) C_2}{2\pi(2H_1 H_2 (H_2 - H_1) + a^2 (H_1 C_2 - H_2 C_1))}$ $\Phi_m = G_3 Q_1 - G_4 Q_2$

DRAWING NUMBER:  
SITE SKETCH

LEGEND:

APPROXIMATE BOREHOLE LOCATION

REFERENCE: PLAN SUPPLIED BY  
SUNBELT RENTALS INC

SPECIAL NOTE: BOREHOLE LOCATIONS AS PER D. B.  
GRAY ENGINEERING REQUEST

REV.	NAME	DATE	DESCRIPTION

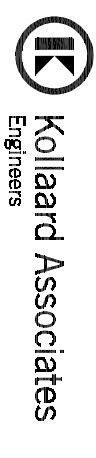

**Kollaard Associates**  
Engineers  
P.O. BOX 189, 210 PRESCOTT ST (613) 860-0923  
KEMPVILLE ONTARIO info@kollaard.ca  
K0G 1J0 FAX (613) 258-0475  
http://www.kollaard.ca

CLIENT:  
SUNBELT RENTALS INC.

PROJECT:  
PROPOSED COMMERCIAL DEVELOPMENT  
STORM POND AND SEPTIC SYSTEM  
BOREHOLE LOCATIONS

LOCATION:  
151-159 WESCAR LANE  
OTTAWA, ONTARIO

DESIGNED BY:  
DATE: JUNE 14, 2023

DRAWN BY:  
DT  
SCALE: N.T.S.

KOLLAARD FILE NUMBER:  
230403

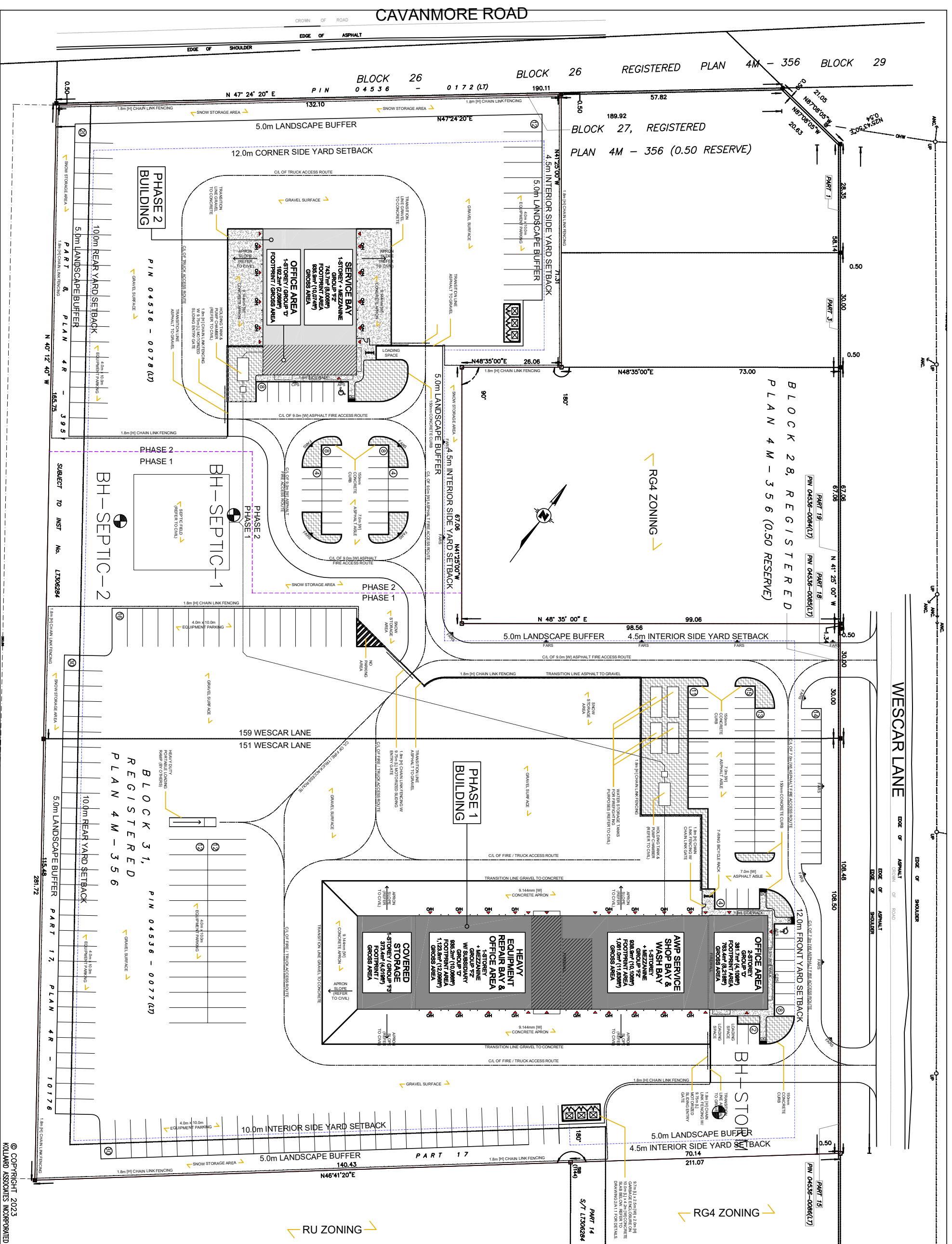

© COPYRIGHT 2023  
KOLLAARD ASSOCIATES INCORPORATED

# 151-159 Wescar Lane Ottawa, Ontario

## INFILTRATION CALCULATIONS

### DRAINAGE AREA II

		C
Roof Area:	3,566 sq.m.	0.90
Asphalt/Concrete Area:	30,832 sq.m.	0.90
Stormwater Detention Area:	897 sq.m.	1.00
Gravel Area:	0 sq.m.	0.80
Landscaped:	4,808 sq.m.	0.20
 Total Catchment Area	 40,103 sq.m.	 0.82

Required Volume Required to Capture:      5      mm rain event:      164.1      cu.m.

64% of days with precipitation are 5mm or less

\* Ottawa International Airport (1981-2010)

Infiltration Trench						
Water	Water	Clear	Clear	Void		
Depth	Volume	Stone	Stone	Volume	40%	Total
m	cu.m.	Depth	Area	Volume	cu.m.	Volume
		m	sq.m.	cu.m.	cu.m.	cu.m.
0.20	169.6	0.00	848	0.0	0.00	169.6

Silt, trace sand

---

Infiltration Rate			
	30	mm/hr	High End of Range
	50	mm/hr	Low End of Range
Design Infiltration Rate (2.5 safety factor)			
	12	mm/hr	High End of Range
Time to Draw Down:	16.7	Hours	
	20	mm/hr	Low End of Range
Time to Draw Down:	10.0	Hours	

# SUMMARY TABLES

100-YEAR EVENT					
Drainage Area	Pre-Development Flow Rate (L/s)	Maximum Allowable Release Rate (L/s)	Maximum Release Rate (L/s)	Maximum Volume Required (cu.m)	Maximum Volume Stored (cu.m)
AREA I (Uncontrolled Flow Off Site)	-	-	87.86	-	-
AREA II	-	-	55.39	2022.78	2022.78
TOTAL	476.49	155.44	143.25	2022.78	2022.78

2-YEAR EVENT					
Drainage Area	Pre-Development Flow Rate (L/s)	Maximum Allowable Release Rate (L/s)	Maximum Release Rate (L/s)	Maximum Volume Required (cu.m)	Maximum Volume Stored (cu.m)
AREA I (Uncontrolled Flow Off Site)	-	-	30.89	-	-
AREA II	-	-	30.82	734.61	734.61
TOTAL	155.44	155.44	61.71	734.61	734.61

# 151-159 Wescar Lane

Ottawa, Ontario

## STORMWATER MANAGEMENT CALCULATIONS

### Modified Rational Method

### PRE-DEVELOPMENT CONDITIONS

#### 100-YEAR EVENT

Total Catchment Area: 46,268 sq.m

C  
0.375

1.25 x Woodland or Pasture - Flat - Clay and Silt Loam as per Table 5.7 Ottawa Sewer Design Guidelines

Airport Formula (Used when C < 0.40)

$$T_c = \frac{3.26 \cdot (1.1 - C) \cdot L^{1/2}}{S_w^{0.33}} \text{ min}$$

Runoff Coefficient (C): 0.375  
 Sheet Flow Distance (L): 130 m  
 Slope of Land (Sw): 1 %  
 Time of Concentration (Sheet Flow): 27 min

Rainfall Intensity (i): 99 mm/hr (100-year event)

100-Year Pre-Development Flow Rate (2.78AiC): 476.49 L/s

#### 2-YEAR EVENT

#### MAXIMUM ALLOWABLE RELEASE RATE

Total Catchment Area: 46,268 sq.m

C  
0.30

Woodland or Pasture - Flat - Clay and Silt Loam as per Table 5.7 Ottawa Sewer Design Guidelines

Airport Formula (Used when C < 0.40)

$$T_c = \frac{3.26 \cdot (1.1 - C) \cdot L^{1/2}}{S_w^{0.33}} \text{ min}$$

Runoff Coefficient (C): 0.30  
 Sheet Flow Distance (L): 130 m  
 Slope of Land (Sw): 1 %  
 Time of Concentration (Sheet Flow): 30 min

Rainfall Intensity (i): 40 mm/hr (2-year event)

5-Year Pre-Development Flow Rate (2.78AiC): 155.44 L/s

# 100-YEAR EVENT

## DRAINAGE AREA I (Uncontrolled Flow Off Site)

(100-YEAR EVENT)

			C
Roof Area:	0	sq.m	1.00
Hard Area:	305	sq.m	1.00
Detention Area:	0	sq.m	1.00
Gravel Area:	0	sq.m	1.00
Soft Area:	<u>5,860</u>	<u>sq.m</u>	<u>0.25</u>
Total Catchment Area:	6,165	sq.m	0.29
Area (A):	6,165	sq.m	
Time of Concentration:	10	min	
Rainfall Intensity (i):	179	mm/hr	
Runoff Coeficient (C):	0.29		
Flow Rate (2.78AiC):	87.86	L/s	

# DRAINAGE AREA II

(100-YEAR EVENT)

			C
Roof Area:	3,566	sq.m	1.00
Asphalt/Concrete Area:	30,832	sq.m	1.00
Detention Area:	897	sq.m	1.00
Gravel Area:	0	sq.m	1.00
Soft Area:	4,808	sq.m	0.25
Total Catchment Area:			40,103 sq.m 0.91

Water Elevation: 122.18 m

Head: 1.88 m

Centroid of ICD Orifice: 120.30 m  
(ICD in Inlet of Culvert)

Invert of Inlet of Culvert: 121.04 m

Orifice Diameter: 138 mm

Orifice Area: 14,944 sq.mm

Discharge Coefficient: 0.61

Maximum Release Rate: 55.39 L/s

### Surface Ponding

Above	Top Area	Depth	Volume	
CB or	(sq.m)	(m)		
CB/MH				
CB-1	6	0.02	0.04	cu.m
CB-5	6	0.02	0.04	cu.m
CB-6	549	0.20	36.93	cu.m
CB-7	197	0.31	46.74	cu.m
CB/MH-8	11	0.02	0.08	cu.m
CB-9	740	0.20	49.78	cu.m
CB-10	814	0.20	54.70	cu.m
CB-10A	430	0.43	124.64	cu.m
CB/MH-11	814	0.20	54.70	cu.m
CB-12	232	0.20	15.59	cu.m
CB-12A	323	0.20	21.74	cu.m
CB/MH-14	655	0.20	44.04	cu.m
CB/MH-15	9	0.03	0.09	cu.m
CB-16	751	0.20	50.46	cu.m
CB/MH-17	769	0.20	51.70	cu.m
CB-18	506	0.20	34.05	cu.m
CB/MH-19	653	0.20	43.90	cu.m
CB-20	756	0.20	50.81	cu.m
CB/MH-21	853	0.20	57.37	cu.m
CB-22	359	0.20	24.14	cu.m
CB/MH-23	504	0.20	33.92	cu.m
CB/MH-24	638	0.20	42.87	cu.m
CB/MH-25	370	0.20	24.89	cu.m

Volume Stored: 863.23 cu.m

### Stormwater Detention Area (above outlet invert elevation: 121.04)

Average	Average	Depth	Volume	
Length	Width	(m)		
(sq.m)	(sq.m)			
68.5	12.7	1.14	989.88	cu.m

### Stormwater Detention Area (below outlet invert elevation: 121.04)

Length	Width	Depth	Volume	
(sq.m)	(sq.m)	(m)		
66.8	12.7	0.20	169.67	cu.m

Maximum Volume Stored: 2022.78 cu.m

Maximum Volume Required: 2022.78 cu.m



## DRAINAGE AREA II (Continued)

(100-YEAR EVENT)

Time (min)	i (mm/hr)	2.78AiC (L/s)	ICD Release Rate (L/s)	Stored Rate (L/s)	Required Storage Volume (cu.m)
10	179	1811.69	55.39	1756.30	1053.78
15	143	1449.83	55.39	1394.44	1254.99
20	120	1217.04	55.39	1161.65	1393.98
25	104	1053.65	55.39	998.26	1497.39
30	92	932.11	55.39	876.72	1578.10
35	83	837.86	55.39	782.47	1643.18
40	75	762.44	55.39	707.05	1696.91
45	69	700.60	55.39	645.21	1742.06
50	64	648.89	55.39	593.50	1780.50
55	60	604.95	55.39	549.56	1813.56
60	56	567.12	55.39	511.73	1842.22
65	53	534.16	55.39	478.77	1867.21
70	50	505.17	55.39	449.78	1889.10
75	47	479.46	55.39	424.07	1908.33
80	45	456.49	55.39	401.10	1925.26
85	43	435.82	55.39	380.43	1940.19
90	41	417.12	55.39	361.73	1953.34
95	39	400.11	55.39	344.72	1964.92
100	38	384.57	55.39	329.18	1975.09
105	36	370.31	55.39	314.92	1983.99
110	35	357.17	55.39	301.78	1991.75
115	34	345.02	55.39	289.63	1998.48
120	33	333.76	55.39	278.37	2004.25
125	32	323.28	55.39	267.89	2009.15
130	31	313.50	55.39	258.11	2013.25
135	30	304.35	55.39	248.96	2016.61
140	29	295.78	55.39	240.39	2019.29
145	28	287.73	55.39	232.34	2021.33
150	28	280.14	55.39	224.75	2022.78
180	24	242.52	55.39	187.13	2021.00
210	21	214.54	55.39	159.15	2005.24
240	19	192.84	55.39	137.45	1979.22
270	17	175.47	55.39	120.08	1945.36
300	16	161.24	55.39	105.85	1905.27
330	15	149.33	55.39	93.95	1860.12
360	14	139.22	55.39	83.83	1810.77
390	13	130.51	55.39	75.12	1757.88
420	12	122.93	55.39	67.54	1701.94
450	11	116.25	55.39	60.87	1643.38
480	11	110.34	55.39	54.95	1582.50
510	10	105.05	55.39	49.66	1519.59
540	9.9	100.29	55.39	44.90	1454.85
570	9.5	95.99	55.39	40.60	1388.49
600	9.1	92.07	55.39	36.69	1320.66
630	8.7	88.50	55.39	33.11	1251.50
660	8.4	85.22	55.39	29.83	1181.11
690	8.1	82.19	55.39	26.80	1109.62
720	7.8	79.40	55.39	24.01	1037.10
750	7.6	76.80	55.39	21.41	963.63
780	7.3	74.39	55.39	19.00	889.29
810	7.1	72.14	55.39	16.75	814.14
840	6.9	70.04	55.39	14.65	738.22
870	6.7	68.06	55.39	12.67	661.60
900	6.5	66.21	55.39	10.82	584.32

## 2-YEAR EVENT

### DRAINAGE AREA I (Uncontrolled Flow Off Site)

(2-YEAR EVENT)

			C
Roof Area:	0	sq.m	0.90
Hard Area:	305	sq.m	0.90
Detention Area:	0	sq.m	0.90
Gravel Area:	0	sq.m	0.80
Soft Area:	<u>5,860</u>	<u>sq.m</u>	<u>0.20</u>
Total Catchment Area:	6,165	sq.m	0.23
Area (A):	6,165	sq.m	
Time of Concentration:	10	min	
Rainfall Intensity (i):	77	mm/hr (2-year event)	
Runoff Coefficient (C):	0.23		
Flow Rate (2.78AiC):	30.89	L/s	

# DRAINAGE AREA II

(2-YEAR EVENT)

			C
Roof Area:	3,566	sq.m	0.90
Asphalt/Concrete Area:	30,832	sq.m	0.90
Detention Area:	897	sq.m	1.00
Gravel Area:	0	sq.m	0.80
Landscaped Area:	4,808	sq.m	0.20
			<hr/>
Total Catchment Area:	40,103	sq.m	0.82

Water Elevation: 121.69 m

Head: 0.58 m

Centroid of ICD Orifice: 121.11 m  
(ICD in Inlet of Culvert)

Invert of Inlet of Culvert: 121.04 m

Orifice Diameter: 138 mm

Orifice Area: 14,944 sq.mm

Discharge Coefficient: 0.61

Maximum Release Rate: 30.82 L/s

## Surface Ponding

Above	Top Area	Depth	Volume	
CB or	(sq.m)	(m)		
CB/MH				
CB-1	0	0.00	0.00	cu.m
CB-5	0	0.00	0.00	cu.m
CB-6	0	0.00	0.00	cu.m
CB-7	0	0.00	0.00	cu.m
CB/MH-8	0	0.00	0.00	cu.m
CB-9	0	0.00	0.00	cu.m
CB-10	0	0.00	0.00	cu.m
CB-10A	0	0.00	0.00	cu.m
CB/MH-11	0	0.00	0.00	cu.m
CB-12	0	0.00	0.00	cu.m
CB-12A	0	0.00	0.00	cu.m
CB/MH-14	0	0.00	0.00	cu.m
CB/MH-15	0	0.00	0.00	cu.m
CB-16	0	0.00	0.00	cu.m
CB/MH-17	0	0.00	0.00	cu.m
CB-18	0	0.00	0.00	cu.m
CB/MH-19	0	0.00	0.00	cu.m
CB-20	0	0.00	0.00	cu.m
CB/MH-21	0	0.00	0.00	cu.m
CB-22	0	0.00	0.00	cu.m
CB/MH-23	0	0.00	0.00	cu.m
CB/MH-24	0	0.00	0.00	cu.m
CB/MH-25	0	0.00	0.00	cu.m

Volume Stored: 0.00 cu.m

## Stormwater Detention Area (above outlet invert elevation: 121.04)

Average	Average	Depth	Volume	
Length	Width	(m)		
(sq.m)	(sq.m)			
68.5	12.7	0.65	564.94	cu.m

## Stormwater Detention Area (below outlet invert elevation: 121.04)

Length	Width	Depth	Volume	
(sq.m)	(sq.m)	(m)		
66.8	12.7	0.20	169.67	cu.m

Maximum Volume Stored: 734.61 cu.m

Maximum Volume Required: 734.61 cu.m

## DRAINAGE AREA II (Continued)

(2-YEAR EVENT)

Time (min)	i (mm/hr)	2.78AiC (L/s)	ICD Release Rate (L/s)	Stored Rate (L/s)	Required Storage Volume (cu.m)
10	77	700.70	30.82	669.88	401.93
15	62	563.51	30.82	532.69	479.42
20	52	474.68	30.82	443.86	532.64
25	45	412.06	30.82	381.24	571.86
30	40	365.32	30.82	334.50	602.10
35	36	328.97	30.82	298.15	626.12
40	33	299.82	30.82	269.00	645.60
45	30	275.88	30.82	245.06	661.65
50	28	255.82	30.82	225.00	675.00
55	26	238.76	30.82	207.93	686.19
60	25	224.04	30.82	193.22	695.59
65	23	211.21	30.82	180.39	703.51
70	22	199.91	30.82	169.09	710.18
75	21	189.88	30.82	159.06	715.77
80	20	180.91	30.82	150.09	720.42
85	19	172.83	30.82	142.01	724.26
90	18	165.52	30.82	134.70	727.37
95	17	158.86	30.82	128.04	729.84
100	17	152.78	30.82	121.96	731.74
105	16	147.19	30.82	116.37	733.12
110	16	142.04	30.82	111.22	734.03
115	15	137.27	30.82	106.45	734.52
120	15	132.85	30.82	102.03	734.61
125	14	128.73	30.82	97.91	734.35
130	14	124.89	30.82	94.07	733.76
135	13	121.30	30.82	90.48	732.87
140	13	117.93	30.82	87.11	731.69
145	13	114.76	30.82	83.94	730.25
150	12	111.77	30.82	80.95	728.57
180	11	96.95	30.82	66.13	714.17
210	9	85.90	30.82	55.08	693.98
240	8	77.32	30.82	46.50	669.55
270	8	70.44	30.82	39.62	641.85
300	7	64.80	30.82	33.98	611.57

151-159 Wescar Lane  
Ottawa, Ontario

## BROAD CRESTED WEIR CALCULATIONS

### 1:100 YEAR EVENT

#### DRAINAGE AREA II

(ONE HUNDRED YEAR EVENT)

Length of Weir based on an assumed coefficient of discharge (Cd):

if Q =	55.39	L/s (maximum 100-year release rate)	assumes Cd= 0.577
=	0.05539	cu.m/s	(assumes P/H is large)
& H =	0.025	m (max. depth of water above top of weir)	
then L =	8.00	m (length of weir)	$L = Q / ((1.705) \times H^{(3/2)})$

Length of Weir based on a calculated coefficient of discharge (Cd):

if P =	1.88	m (depth of pond)	
& Lp =	10.6	m (width of pond perpendicular to direction of flow)	
then Vp =	0.00	m/s (velocity in pond)	$Vp = Q / ((P+H) / Lp)$
& E =	0.025	m (energy)	$E = H + V^2/2g$
& Cd =	0.577		$= 0.577 \times (E/H)^{(3/2)}$
if Q =	55.39	L/s (maximum permitted flow)	
=	0.05539	cu.m/s	
& H =	0.025	m (depth of water above top of weir)	
then L =	8.00	m (length of weir)	$L = Q / (Cd^{(2/3)} \times (2 \times 9.81)^{(1/2)} \times H^{(3/2)})$

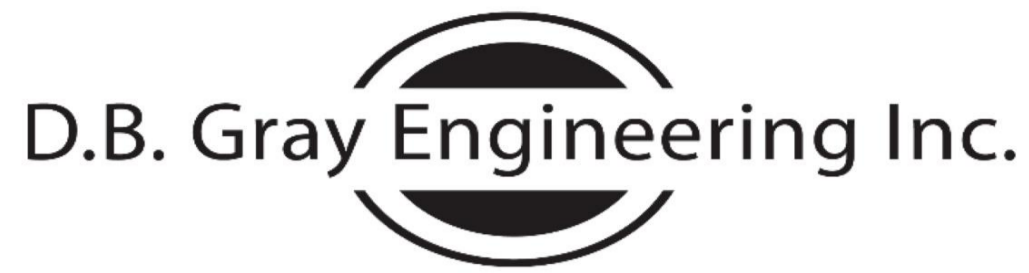

STORM SEWER CALCULATIONS

Rational Method

TWO YEAR EVENT

Stormwater Management - Grading & Drainage - Storm & Sanitary Sewers - Watermains

700 Long Point Circle  
Ottawa, Ontario K1T 4E9

613-425-8044  
d.gray@dbgrayengineering.com

151-159 Wescar Ln  
Equipment Maintenance Facility  
Ottawa, Ontario

January 28, 2025

Manning's Roughness Coefficient: 0.013

Location		Individual				Cumulative				Sewer Data									
		Roof C = 0.90 (ha)	Hard C = 0.90 (ha)	Gravel C = 0.70 (ha)	Soft C = 0.20 (ha)	2.78AC	2.78AC	Time (min)	Rainfall Intensity (mm/hr)	Flow Rate (L/s)	Length (m)	Nominal Diameter (mm)	Actual Diameter (mm)	Slope (%)	Velocity (m/s)	Q <sub>Full</sub> Capacity (L/s)	Time (min)	Q / Q <sub>Full</sub>	
From	To																		
CB-27	Phase 2 Building		0.0163			0.0408	0.0408	10.00	77	3.13	1.5	250	251	2	1.72	85.00	0.01	0.04	
CB-1	CB/MH-2		0.2041		0.0335	0.5293	0.5293	10.00	77	40.65	18	300	299	0.34	0.80	55.89	0.38	0.73	
CB/MH-2	CB/MH-3	0.0234	0.2211			0.6117	1.1410	10.38	75	86.02	61.3	375	366	0.26	0.80	83.79	1.28	1.03	
CB/MH-3	CB/MH-8	0.0234	0.0485		0.0564	0.2113	1.3931	11.66	71	98.87	23.9	375	366	0.26	0.80	83.79	0.50	1.18	
CB-4	CB/MH-8	0.0234	0.3523		0.0184	0.9502	0.9502	10.00	77	72.98	26.6	375	366	0.26	0.80	83.79	0.56	0.87	
CB-5	CB/MH-8		0.0429		0.0107	0.1133	0.1133	10.00	77	8.70	6.2	250	251	0.43	0.80	39.41	0.13	0.22	
CB-6	CB/MH-8		0.1149		0.0143	0.2954	0.2954	10.00	77	22.69	19.7	250	251	0.43	0.80	39.41	0.41	0.58	
CB-7	CB/MH-8		0.0256		0.0447	0.0889	0.0889	10.00	77	6.83	3.8	250	251	0.43	0.80	39.41	0.08	0.17	
CB/MH-8	CB/MH-11	0.0234	0.1022		0.0426	0.3379	3.1788	12.16	69	220.61	94.4	450	457	0.195	0.80	131.19	1.97	1.68	
CB-9	CB/MH-11	0.0187	0.0944			0.2830	0.2830	10.00	77	21.73	28.3	250	251	0.43	0.80	39.41	0.59	0.55	
CB-10	CB/MH-11	0.0568	0.1877			0.6117	0.6117	10.00	77	46.98	8.6	375	366	0.26	0.80	83.79	0.18	0.56	
CB-10A	CB/MH-11		0.0310		0.0583	0.1100	0.1100	10.00	77	8.45	13.7	250	251	0.43	0.80	39.41	0.29	0.21	
CB/MH-11	CB/MH-14	0.0371	0.1305			0.4193	4.6029	14.13	64	294.16	68.6	450	457	0.195	0.80	131.19	1.43	2.24	
CB-12A	CB/MH-14		0.0633		0.0037	0.1604	0.1604	10.00	77	12.32	15	250	251	0.43	0.80	39.41	0.31	0.31	
CB-12	CB/MH-14		0.0373		0.0132	0.1007	0.1007	10.00	77	7.73	7.8	250	251	0.43	0.80	39.41	0.16	0.20	
CB-13	CB/MH-14		0.0223		0.0014	0.0566	0.0566	10.00	77	4.35	9.7	250	251	0.43	0.80	39.41	0.20	0.11	
CB/MH-14	CB/MH-15		0.0962		0.0177	0.2505	5.1711	15.56	60	312.77	61.1	450	457	0.195	0.80	131.19	1.27	2.38	
CB/MH-15	Detention Area	0.0378	0.0321			0.1749	5.3460	16.83	58	308.79	31.9	450	457	0.195	0.80	131.19	0.66	2.35	
CB-16	CB/MH-17		0.1785		0.0580	0.4789	0.4789	10.00	77	36.78	28.3	250	251	0.43	0.80	39.41	0.59	0.93	
CB/MH-17	CB/MH-19		0.1486		0.0550	0.4024	0.8812	10.59	75	65.74	28.3	375	366	0.26	0.80	83.79	0.59	0.78	
CB-18	CB/MH-19		0.0783		0.0104	0.2017	0.2017	10.00	77	15.49	28.3	250	251	0.43	0.80	39.41	0.59	0.39	
CB/MH-19	CB/MH-21		0.0676		0.0052	0.1720	1.2549	11.18	73	91.03	28.3	375	366	0.26	0.80	83.79	0.59	1.09	
CB-20	CB/MH-21		0.1251		0.0080	0.3174	0.3174	10.00	77	24.38	28.3	250	251	0.43	0.80	39.41	0.59	0.62	
CB/MH-21	CB/MH-23		0.1131		0.0081	0.2875	1.8599	11.78	71	131.30	28	375	366	0.26	0.80	83.79	0.59	1.57	
CB-22	CB/MH-23		0.1269		0.0066	0.3212	0.3212	10.00	77	24.67	30.1	250	251	0.43	0.80	39.41	0.63	0.63	
CB/MH-23	CB/MH-24		0.0982			0.2457	2.4267	12.36	69	166.93	32.3	450	457	0.195	0.80	131.19	0.67	1.27	
CB/MH-24	CB/MH-25	0.0187	0.1274			0.3655	2.7923	13.04	67	186.61	36.3	450	457	0.195	0.80	131.19	0.76	1.42	
CB/MH-25	Detention Area	0.0371	0.0860		0.0092	0.3131	3.1054	13.79	65	201.15	10.5	450	457	0.195	0.80	131.19	0.22	1.53	
Detention Area	MH-26	0.0568	0.1108		0.0951	0.4722	8.9236	17.49	56	503.69	5.6	450	457	1.00	1.81	297.09	0.05	1.70	
										FLOW THROUGH ICD:	31.40	5.6	450	457	1.00	1.81	297.09	0.05	0.11
MH-26	Ditch					0.0000	8.9236	17.55	56	502.80	2.7	450	457	1.00	1.81	297.09	0.02	1.69	

## **APPENDIX D**

### **PRE-CONSULTATION MEETING NOTES & CITY OF OTTAWA SERVICING STUDY CHECKLIST**

## **Pre-Application Consultation Meeting Notes**

**Property Address:** 151, 159 Wescar Lane  
PC2023-0019  
February 14, 2023

### **Attendees:**

**Sarah McCormick**, Planner II, City of Ottawa  
**Brian Morgan**, Project Manager, City of Ottawa  
**Mark Elliot**, Environmental Planner II, City of Ottawa  
**Patrick McMahon**, Transportation Engineer, City of Ottawa

**Keith Riley**, Argue Construction Ltd.  
**Shawn Argue**, Argue Construction Ltd.  
**Mark Watson**, Sunbelt Rentals Inc.  
**Jason Tieman**, Sunbelt Rentals Inc.  
**Patrick Swaim**, Sunbelt Rentals Inc.  
**Peter Mansfield**, P Mansfield architect  
**Tom Bonhomme**, P Mansfield architect  
**Doug Gray**, DB Gray Engineering

### **Regrets:**

**Anissa McAlpine**, Parks Planner II, City of Ottawa  
**Mercedes Liedtke**, Planner, MVCA

**Subject: 151, 159 Wescar Lane**

### **Meeting notes:**

#### **Development Proposal**

- Merge and consolidate the lots as part of the proposal.
- Previous land owner cleared all the trees.
- 3 entrances; 2 larger for truck access, one smaller for workers/clients.
- The owner intends to construct a new 2,617 sq metres (footprint) equipment maintenance facility, with related offices on this property.
- This property will be serviced with a private well and septic system.
- With the building footprint being over 600 sq metres (Part 3), it will require on site water storage for fire-fighting purposes.
- Occupancy projection – 55 people
- TIA screening was submitted
- SWM – site drains from NW to SE; why they chose location of pond.



Preliminary comments and questions from staff and agencies, including follow-up actions:

## Planning

### *Official Plan*

- The Subject Properties are designated Rural Industrial and Logistics on Schedule B9 of the Official Plan
- Section 10.1.7 of the Official Plan requires that:
  - (4) Land within three kilometres of an operating Solid Waste Disposal Site boundary is considered to be within the influence area of the site. New lot creation within this zone will require a notice on title to ensure the impacts of the operating Solid Waste Disposal Site (i.e. noise, dust, odours and haul route) are provided.
  - (5) Development within the influence area of an operating Solid Waste Disposal Site shall demonstrate that the Solid Waste Disposal Site shall not have any unacceptable adverse effects on the proposed development and will not pose any risks to human health and safety.
- The properties are identified as being subject to Area-Specific Policies (Area 8) in Annex 5 of the Official Plan. This relates to the former Carp Road Corridor CDP. The Area Specific Policies are found in Volume 2C of the Official Plan.
- The Area Specific Policies (area 8) identify that lands designated as light industrial (as seen in the Carp Road Corridor CDP), permitted uses include, but are not limited to; light manufacturing, warehouse, distribution, storage, service and repair, and transportation depots. Commercial uses are prohibited.

### *Zoning By-law*

- The Subject Properties are zoned Rural General Industrial, Subzone 4 (RG4)
- Heavy equipment and vehicle sales, rental and servicing is a permitted use on the property.
- An office accessory to a principle permitted use is also permitted under the current zoning.

### *Discussion*

- Fueling Station – where permitted, must be only for private use accessory to the principal use of the building(s)
  - TSSA approval may be required, based on the size of the tanks
  - Ensure adequate accessibility and protection of the fueling station and tanks
  - Staff will look into the verbiage in the zoning and provide feedback on whether a fueling station is permitted on the property.
- Site Plan must demonstrate protection of septic field using bollards/large rocks
- Staff would be looking to have trees re-instated on the lot towards achieving a 30-40% tree canopy coverage as identified in the Official Plan.

- The site plan should be re-worked to accommodate for a minimum of a 5m landscape buffer along the perimeter of the site; this includes a landscape buffer between the SWM pond and the property line.
- Vacant corners in the parking lot should also be landscaped.
- From the images provided, trees within the Cavanmore ROW have been cleared. Re-instatement of trees will be required as part of the site plan review process. Through the Site Plan review process, the City's forestry department will be circulated to determine compensation.
- Given the property is located within 3km of a solid waste disposal site, an 'Impact Assessment – Waste Disposal Sites' is required demonstrating the Solid Waste Disposal Site shall not have any unacceptable adverse effects on the proposed development and will not pose any risks to human health and safety.
- When preparing the site plan, please ensure the following are considered in the design:
  - Refuse collection area;
    - this must be screened by a 2m opaque fence, which has no gaps between boards.
    - Refuse collection areas must be located a minimum of 9m from a lot line abutting a street and a minimum of 3m from any other lot lines.
    - Snow storage
    - Zoning chart listing the above as well as parking calculation for the proposed uses. Parking rates can be found in Section 101 of the Zoning By-law. Bicycle parking (Section 111) must also be provided in the zoning chart
- Staff note that there is an area adjacent to Cavanmore Road that is identified as having archaeological potential. An archaeological Report will be required when approvals for Phase 2 are considered.
- Subdivision agreement was reviewed, and while it does not explicitly state that access from Cavanmore is prohibited, a reserve was put in place along the property line. These reserves are typically used in subdivisions to limit access. It is unlikely staff would support the lifting of the reserve along Cavanmore to provide access to the subject properties.
- Given the information provided, the project will trigger a **Complex Site Plan Application**
  - Staff would recommend that the Phase 2 lands are simply identified on the Site Plan as 'reserved for future development' and no buildings are shown.
  - A Site Plan Revision application would be required when the owner is prepared to continue with the second phase of development.
- Bill 109 will impact the Site Plan Control processes related to this proposal. The City is considering new processes for how Planning staff will review Site Plan Control (and Zoning By-law Amendment) applications to meet the aggressive timelines set out in the Provincial legislation and ensure we are complying with the new regulations. While staff do not have anything definitive to provide at this time, the intention is that a report will be brought forward to Council in April, with the new process.

- Staff note that it is anticipated that if Site Plan applications are not submitted and deemed adequate by the time Council approves the new process, that a phased pre-consult may be required for this file.

### Transportation

- A TIA is not required for this development.
- On site plan:
  - Show all details of the roads abutting the site; include such items as pavement markings and accesses;
  - Turning templates will be required for all accesses showing the largest vehicle to access the site; required for internal movements and at all access (entering and exiting and going in both directions);
  - Show lane/aisle widths.
  - Label the 26m ROW protection along the Cavanmore Road frontage. It does not appear that a widening is required.
- As per the Private Approach By-Law, only two two-way private approaches or one two-way and two one-way private approaches are allowed in 137m of frontage.
- As the proposed site is commercial/industrial and for general public use, AODA legislation applies. Ensure that an access aisle and curb depression are provided for the accessible parking space.

### Mississippi Valley Conservation Authority

- Given Provincial legislative changes, the involvement of Conservation Authorities is now more limited.
- The MVCA has noted that the property is not regulated by the Mississippi Valley Conservation Authority (MVCA) under Ontario Regulation 153/06, *Development, Interference with Wetlands and Alterations to Shorelines and Watercourses*.

### Parks

- Parkland dedication will be required for the development in the form of Cash in Lieu (CIL) of parkland.
- The required rates for parkland dedication for commercial and industrial purpose developments, as per the City of Ottawa Parkland Dedication By-law No. 2022-280 calculated as 2% of the gross land area of the site being developed. Therefore, the parkland dedication requirement is calculated as follows:
  - a. Gross Land Area: ..... 4.564 (45642 sq m )
  - b. Parkland Dedication requirements (2% of 'a'): ..... 0.091 ha
- Parks & Facilities Planning is requesting payment of Cash-in-lieu-of-Parkland for this development. The value of the land, will be determined as of the day before the building permit is issued.

### Environmental

- This application will require an EIS. There are natural heritage features within the 120m trigger to the west of the site, and the area across the road to the north is the part of the natural

heritage system core area. It should be noted that the NHS core area has a higher standard of protection than usual. From 5.6.4.1 of the OP:

“In Natural Heritage System Core Areas, development or site alteration shall maintain or enhance the integrity, biodiversity and ecosystem services of the area; and, not compromise the potential for longterm enhancement and restoration of the ecological integrity, biodiversity and ecosystem services of the area...”

- The EIS should address the significant woodlands, wildlife habitat, light pollution, and linkages of both the areas to the west and north. Additionally, there is some discrepancy between municipal and provincial mapping with the province showing a small area of wetland just west of the property which may trigger wetland setbacks if it is present. This needs to be investigated as well. The EIS should incorporate mitigation measures from the Protocols for Wildlife Protection During Construction.
- A TCR looking into the critical root zone of trees on neighbouring properties should be provided. It may be incorporated into the EIS.
- As discussed, the city right of way has been cleared and will need to be replanted. A planting plan that addresses the right of way and incorporates vegetated buffers of 5m or more along the edges of the site where feasible is required. This should be coordinated with Forestry.

## Engineering

### General:

- All dimensions and areas must be in metric units.
- All elevations provided in drawings and reports submitted to the City must be geodetic.
- Please indicate the Site Benchmark and the external reference that provides the horizontal and vertical datum of the reference used to set this benchmark.
- Bollards must be provided around sensitive servicing or infrastructure.
- Indicate snow storage areas on the Site plan. Note that these areas are not to interfere with stormwater flows or servicing.

### Geotechnical Report

- The geotechnical investigation should include:
  - On-site boreholes or test pits complete with borehole logs.
  - On-site groundwater level.
  - All elevations must be geodetic.
  - Liquefaction statement. Is this likely to be an issue on this site, or not?
  - Thin soils statement. Is this likely to be present on this site, or not?
  - Sensitive marine clays statement. Is this likely to be present on this site, or not?
- All as per the City web site [Geotechnical Investigation and Reporting Guidelines for Development Applications in the City of Ottawa](#)

### Hydrogeological & Terrain Analysis

- The quantity criteria for the development is that the 100-yr post development peak flow rate must match the 2-year pre-development peak flow rate.
- The quality criteria for this site is TSS removal rate of 80%

- All as per the City Website: City of Ottawa Sewer Design Guidelines Revised Section 8 – Stormwater Management. (Not presently available online, information requests can be made by contacting [StandardsSection@ottawa.ca](mailto:StandardsSection@ottawa.ca) )

#### Oil/Grit separators

- Note that if the oil/grit separators are to drain to a ditch, then the applicant will need to receive ECA approval from the MECP.
- If the oil/grit separators are out-letting to the septic tank, this will increase the volume to the system significantly. Sanitary flows over 10,000 L/day will require ECA Approv.

#### Other

- The City requires an approved septic permit to be submitted prior to Site Plan approval.
- Consult with Allan Evans in Fire Services regarding fire tanks and fire separation walls.  
[Allan.evans@ottawa.ca](mailto:Allan.evans@ottawa.ca)
- Fire Routes now require review and designation by By-law. Contact:  
[fireroutes@ottawa.ca](mailto:fireroutes@ottawa.ca)
- The City will require an Exterior Lighting Certificate certified by a qualified engineer.

#### Next steps

- It is encourage that you discuss the proposal with the Ward Councillor, local community groups and neighbours

## **GENERAL**

Executive Summary: **N/A**

Date and revision number of report: **Included**

Location map and plan showing municipal address, boundary and layout of proposed development: **Included**

Plan showing site and location of all existing services: **Included**

Development statistics, land use, density, adherence to zoning and Official Plan and reference to applicable watershed and subwatershed plans: **N/A**

Summary of Pre-Application Consultation meetings with City of Ottawa and other approval agencies: **Included**

Confirmation of conformance with higher level studies: **N/A**

Statement of objectives and servicing criteria: **Included**

Identification of existing and proposed infrastructure available in the immediate area: **Included**

Identification of Environmentally Significant Areas, watercourses and Municipal Drains potentially impacted by the proposed development: **N/A**

Concept level master grading plan to confirm existing and proposed grades in the proposed development: **Included**

Identification of potential impacts of proposed piped services on private services on adjacent lands: **N/A**

Proposed phasing of proposed development: **N/A**

Reference to geotechnical studies: **Included**

All preliminary and formal site plan submissions should have the following information:

Metric scale: **Included**

North arrow: **Included**

Key plan: **Included**

Property limits: **Included**

Existing and proposed structures and parking areas: **Included**

Easements, road widenings and right-of-ways: **Included**

Street names: **Included**

## **WATER SERVICING**

Confirmation of conformance with Master Servicing Study: **N/A**

Availability of public infrastructure to service proposed development: **Included**

Identification of system constraints: **Included**

Identification of boundary conditions: **Included**

Confirmation of adequate domestic supply: **Included**

Confirmation of adequate fire flow: **Included**

Check of high pressures: **Included**

Definition of phasing constraints: **N/A**

Address reliability requirements: **N/A**

Check on necessity of a pressure zone boundary modification: **N/A**

Reference to water supply analysis to show that major infrastructure is capable of delivering sufficient water for proposed development: **Included**

Description of proposed water distribution network: **Included**

Description of required off-site infrastructure to service proposed development: **N/A**

Confirmation that water demands are calculated based on the City of Ottawa Water Design Guidelines: **Included**

Provision of a model schematic showing the boundary conditions locations, streets, parcels and building locations: **Included**

## **SANITARY SERVICING**

Summary of proposed design criteria: **Included**

Confirmation of conformance with Master Servicing Study: **N/A**

Consideration of local conditions that may contribute to extraneous flows that are higher than the recommended flows in the City of Ottawa Sewer Design Guidelines: **N/A**

Description of existing sanitary sewer available for discharge of wastewater from proposed development: **Included**

Verification of available capacity in downstream sanitary sewer and/or identification of upgrades necessary to service proposed development: **N/A**

Calculations related to dry-weather and wet-weather flow rates: **Included**

Description of proposed sewer network: **Included**

Discussion of previously identified environmental constraints and impact on servicing: **N/A**

Impacts of proposed development on existing pumping stations or requirements for new pumping station: **N/A**

Forcemain capacity in terms of operational redundancy, surge pressure and maximum flow velocity: **N/A**

Identification and implementation of emergency overflow from sanitary pumping stations in relation to the hydraulic grade line to protect against basement flooding: **N/A**

Special considerations (e.g. contamination, corrosive environment): **N/A**

## **STORMWATER MANAGEMENT & STORM SERVICING**

Description of drainage outlets and downstream constraints: **Included**

Analysis of available capacity in existing public infrastructure: **N/A**

Plan showing subject lands, its surroundings, receiving watercourse, existing drainage pattern and proposed drainage pattern: **Included**

Water quantity control objective: **Included**

Water quality control objective: **Included**

Description of the stormwater management concept: **Included**

Setback from private sewage disposal systems: **N/A**

Watercourse and hazard lands setbacks: **N/A**

Record of pre-consultation with the Ministry of the Environment, Conservation and Parks and the Conservation Authority having jurisdiction on the affected watershed: **N/A**

Confirmation of conformance with Master Servicing Study: **N/A**

Storage requirements and conveyance capacity for minor events (5-year return period) and major events (100-year return period): **Included**

Identification of watercourses within the proposed development and how watercourses will be protected or if necessary altered by the proposed development: **N/A**

Calculation of pre-development and post-development peak flow rates: **Included**

Any proposed diversion of drainage catchment areas from one outlet to another: **N/A**



Proposed minor and major systems: **Included**

If quantity control is not proposed, demonstration that downstream system has adequate capacity for the post-development flows up to and including the 100-year return period storm event: **N/A**

Identification of potential impacts to receiving watercourses: **N/A**

Identification of municipal drains: **N/A**

Description of how the conveyance and storage capacity will be achieved for the proposed development: **Included**

100-year flood levels and major flow routing: **Included**

Inclusion of hydraulic analysis including hydraulic grade line elevations: **N/A**

Description of erosion and sediment control during construction: **Included**

Obtain relevant floodplain information from Conservation Authority: **N/A**

Identification of fill constraints related to floodplain and geotechnical investigation: **N/A**

## **APPROVAL AND PERMIT REQUIREMENTS**

Conservation Authority as the designated approval agency for modification of floodplain, potential impact on fish habitat, proposed works in or adjacent to a watercourse, cut/fill permits and Approval under Lakes and Rivers Improvement Act. The Conservation Authority is not the approval authority for the Lakes and Rivers Improvement Act. Where there are Conservation Authority regulations in place, approval under the Lakes and Rivers Improvement Act is not required, except in cases of dams as defined in the Act: **N/A**

Application for Certificate of Approval (CofA) under the Ontario Water Resources Act: **N/A**

Changes to Municipal Drains: **N/A**

Other permits (e.g. National Capital Commission, Parks Canada, Public Works and Government Services Canada, Ministry of Transportation): **N/A**

## **CONCLUSIONS**

Clearly stated conclusions and recommendations: **Included**

Comments received from review agencies: **N/A**

Signed and stamped by a professional Engineer registered in Ontario: **Included**