

# MULTI HOUSING ORLÉANS

3479 ST-JOSEPH BOULEVARD

SUBMISSION PHASE 3 - V2 - 2024-12-20



Lemay Michaud

111, rue Saint-Pierre, Québec QC G1K 4A6

PROJECT

MULTI HOUSING - ORLÉANS  
3479 ST. JOSEPH BOULEVARD  
OTTAWA, QC

CLIENT

ISABEL CHARBONNEAU  
PAUL-ANDRÉ CHARBONNEAU

CONSULTANT

SCALE :

REVISIONS

No	DATE	DESCRIPTION
1	2020-05-10	ÉMIS POUR COORDINATION
2	2020-05-26	ÉMIS POUR INFORMATION
3	2020-06-25	ÉMIS POUR INFORMATION
4	2020-08-30	ÉMIS POUR INFORMATION
5	2020-08-16	ÉMIS POUR INFORMATION
6	2022-04-05	ÉMIS POUR INFORMATION
7	2022-08-24	ÉMIS POUR INFORMATION
8	2022-04-20	ÉMIS POUR INFORMATION
9	2022-07-05	ÉMIS POUR INFORMATION
10	2023-07-06	ÉMIS POUR COORDINATION
11	2023-07-14	ÉMIS POUR COORDINATION
12	2023-12-06	ÉMIS POUR COORDINATION
13	2024-06-26	ÉMIS POUR INFORMATION
14	2024-12-20	SUBMISSION PHASE 3 CITY - V2

SEAL

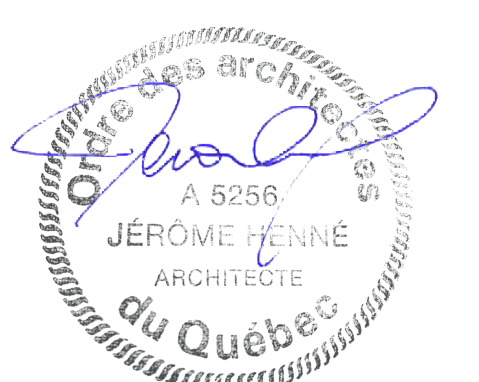

NOTES

IT IS THE CONTRACTOR'S RESPONSIBILITY TO VERIFY ALL MEASUREMENTS AND DIMENSIONS ON SITE PRIOR TO PROCEEDING WITH THIS WORK.  
THIS DOCUMENT REMAINS THE PROPERTY OF LEMAYMICHAUD ARCHITECTURE DESIGN AND IS TO BE USED ONLY FOR THE SPECIFIC PURPOSE FOR WHICH IT IS INTENDED.

FOLDER

109821B

PAGE



Lemay Michaud

111, rue Saint-Pierre, Québec QC G1K 4A6

PROJECT  
MULTI HOUSING - ORLÉANS  
3479 ST. JOSEPH BOULEVARD  
OTTAWA, QC

CLIENT  
ISABEL CHARBONNEAU  
PAUL-ANDRÉ CHARBONNEAU

CONSULTANT

SITE PLAN

SCALE :

No	DATE	DESCRIPTION
1	2020-05-10	EMIS POUR COORDINATION
2	2020-05-26	EMIS POUR INFORMATION
3	2020-06-25	EMIS POUR INFORMATION
4	2020-06-30	EMIS POUR INFORMATION
5	2020-08-18	EMIS POUR INFORMATION
6	2022-04-05	EMIS POUR INFORMATION
7	2022-04-24	EMIS POUR INFORMATION
8	2022-04-20	EMIS POUR INFORMATION
9	2022-07-05	EMIS POUR INFORMATION
10	2023-07-06	EMIS POUR COORDINATION
11	2023-07-14	EMIS POUR COORDINATION
12	2023-12-06	EMIS POUR COORDINATION
13	2024-06-26	EMIS POUR INFORMATION
14	2024-12-20	SUBMISSION PHASE 3 CITY - V2



NOTES  
IT IS THE CONTRACTOR'S RESPONSIBILITY TO VERIFY ALL MEASUREMENTS AND DIMENSIONS ON SITE PRIOR TO PROCEEDING WITH THIS WORK.  
THIS DOCUMENT REMAINS THE PROPERTY OF LEMAYMICHAUD ARCHITECTURE DESIGN AND IS TO BE USED ONLY FOR THE SPECIFIC PURPOSE FOR WHICH IT IS INTENDED.

FOLDER  
109821B

PAGE  
A-100

LÉGENDE

- LOT BOUNDARY
- GREEN AREA
- RAISED GREEN AREA
- PARKING PROFILE
- PROPOSED BUILDING
- PAVED GROUND AREA
- MID-BOULEVARD LINE AND PROTECTION ROW
- MID-ACCESS ROAD MEDIAN FIRE SERVICE ACCESS

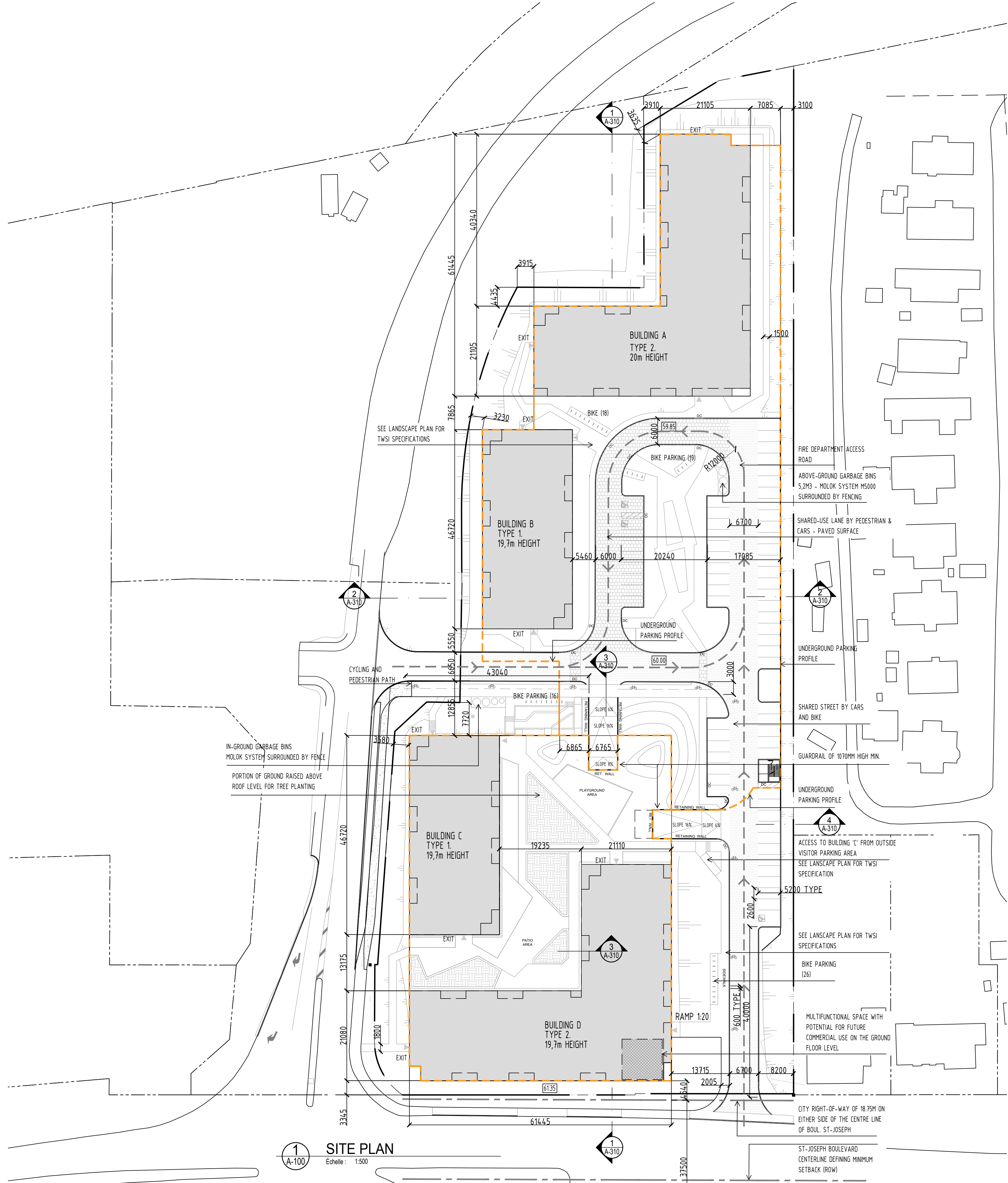
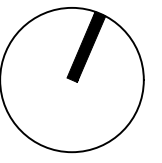

PROJECT'S STATISTICS

NUMBER OF UNITS	
BUILDING A:	103 UNITS
BUILDING B:	60 UNITS
BUILDING C:	60 UNITS
BUILDING D:	103 UNITS
TOTAL:	326 UNITS

UNIT TYPES	
1 BEDROOM:	172 UNITS
2 BEDROOMS:	154 UNITS

LOT AREA	
% OF GREEN AREA ON SITE:	36.6% (6 533 M <sup>2</sup> / 17 813 M <sup>2</sup> )
% OF BUILT-UP AREA:	32.45% (5 782.8 / 17 813 M <sup>2</sup> )
GROSS FLOOR AREA :	23 082.35 M <sup>2</sup>

AMENITY AREAS	
OUTDOOR AREA:	920 M <sup>2</sup>
BALCONY:	1 025.5 M <sup>2</sup>
INDOOR COMMON AREA (GROUND FLOOR OF BUILDINGS A & D):	178.5 M <sup>2</sup>
TOTAL:	2 124 M <sup>2</sup> (1 956 M <sup>2</sup> REQUIRED)

WASTE MANAGEMENT	
CONTAINER VOLUMES OUTSIDE	
GARBAGE:	5 M <sup>3</sup> x 2 BIN
PAPER:	5 M <sup>3</sup> x 2 BIN
GLASS, METAL, PLASTIC:	3 M <sup>3</sup> x 2 BINS
ORGANIC MATTER:	1,3 M <sup>3</sup> x 1BIN + 3 M <sup>3</sup> x 1BIN

PARKING SPACES	
UNDERGROUND SPACES:	375 SPACES (391 REQUIRED - 20 SPACES)
NUMBER OF OUTDOOR SPACES:	65 SPACES (65 REQUIRED)
TOTAL:	440 SPACES

BIKE PARKING	
NUMBER OF OUTDOOR SPACES:	80 SPACES
NUMBER OF BASEMENT SPACES:	86 SPACES
TOTAL:	166 SPACES (163 REQUIRED)

APPLICABLE REGULATIONS

ZONING PROVISIONS: GM13(4-34)H(20)

MINIMUM AREA:	NO MINIMUM
MINIMUM LOT WIDTH:	NO MINIMUM
FRONT YARD SETBACK:	MINIMUM 3 M
INTERIOR SIDE YARD SETBACK:	MINIMUM 3 M
REAR YARD SETBACK:	7.5 M / NO MINIMUM
MINIMUM NUMBER OF STOREYS:	2
MAXIMUM BUILDING HEIGHT:	20 M
MINIMUM LANDSCAPE SPACE WIDTH:	MINIMUM 3 M
RESIDENTIAL PARKING:	1.2 SPACES PER UNIT REQUIRED (AREA C) REDUCED BY 10% OR 20 SPACES, WHICHEVER IS LESS, IF ALL SPACES ARE UNDERGROUND.
VISITOR PARKING:	0.2 SPACES PER UNIT
REQUIRED (AREA C)	
MIN. DIMENSIONS OF PARKING SPACES:	2.6 M X 5.2 M
	2.6 M X 6.7 M (PARALLEL SPACES)
DRIVEWAY FOR UNDERGROUND PARKING:	MAX. 6.7 M / MIN. 6 M
MIN. NUMBER OF BICYCLE PARKING:	0.5 PER DWELLING UNIT
RECREATION AREA:	6 M <sup>2</sup> PER DWELLING UNIT

ADDITIONAL PROVISIONS FOR PLANNED UNIT DEVELOPMENT

MIN. PRIVATE ROAD WIDTH:	6 M
MIN. DISTANCE BETWEEN BUILDING AND ROAD:	1.8 M
MIN. SEPARATION BETWEEN BUILDINGS:	3 M

PARKING:  
IN ADDITION TO PROVIDING PARKING IN ACCORDANCE WITH ARTICLE 100 OF THIS REGULATION, PARKING IN A PLANNED UNIT DEVELOPMENT MAY BE LOCATED ANYWHERE WITHIN THE DEVELOPMENT, WHETHER THE DEVELOPMENT PARCELS WITHIN THE PLANNED UNIT DEVELOPMENT ARE SEPARATED OR NOT.

SITE PLAN

Echelle: 1:500



Lemay Michaud

111, rue Saint-Pierre, Québec QC G1K 4A6

PROJECT  
MULTI HOUSING - ORLÉANS  
3479 ST. JOSEPH BOULEVARD  
OTTAWA, QC

CLIENT  
ISABEL CHARBONNEAU  
PAUL-ANDRÉ CHARBONNEAU

CONSULTANT

UNDERGROUND PARKING

SCALE :

No	DATE	DESCRIPTION
1	2020-05-10	EMIS POUR COORDINATION
2	2020-05-26	EMIS POUR INFORMATION
3	2020-08-25	EMIS POUR INFORMATION
4	2020-08-30	EMIS POUR INFORMATION
5	2020-08-18	EMIS POUR INFORMATION
6	2022-04-05	EMIS POUR INFORMATION
7	2024-06-26	EMIS POUR INFORMATION
8	2024-12-20	SUBMISSION PHASE 3 CITY - V2



NOTES  
IT IS THE CONTRACTOR'S RESPONSIBILITY TO VERIFY ALL MEASUREMENTS AND DIMENSIONS ON SITE PRIOR TO PROCEEDING WITH THIS WORK.  
THIS DOCUMENT REMAINS THE PROPERTY OF LEMAYMICHAUD ARCHITECTURE DESIGN AND IS TO BE USED ONLY FOR THE SPECIFIC PURPOSE FOR WHICH IT IS INTENDED.

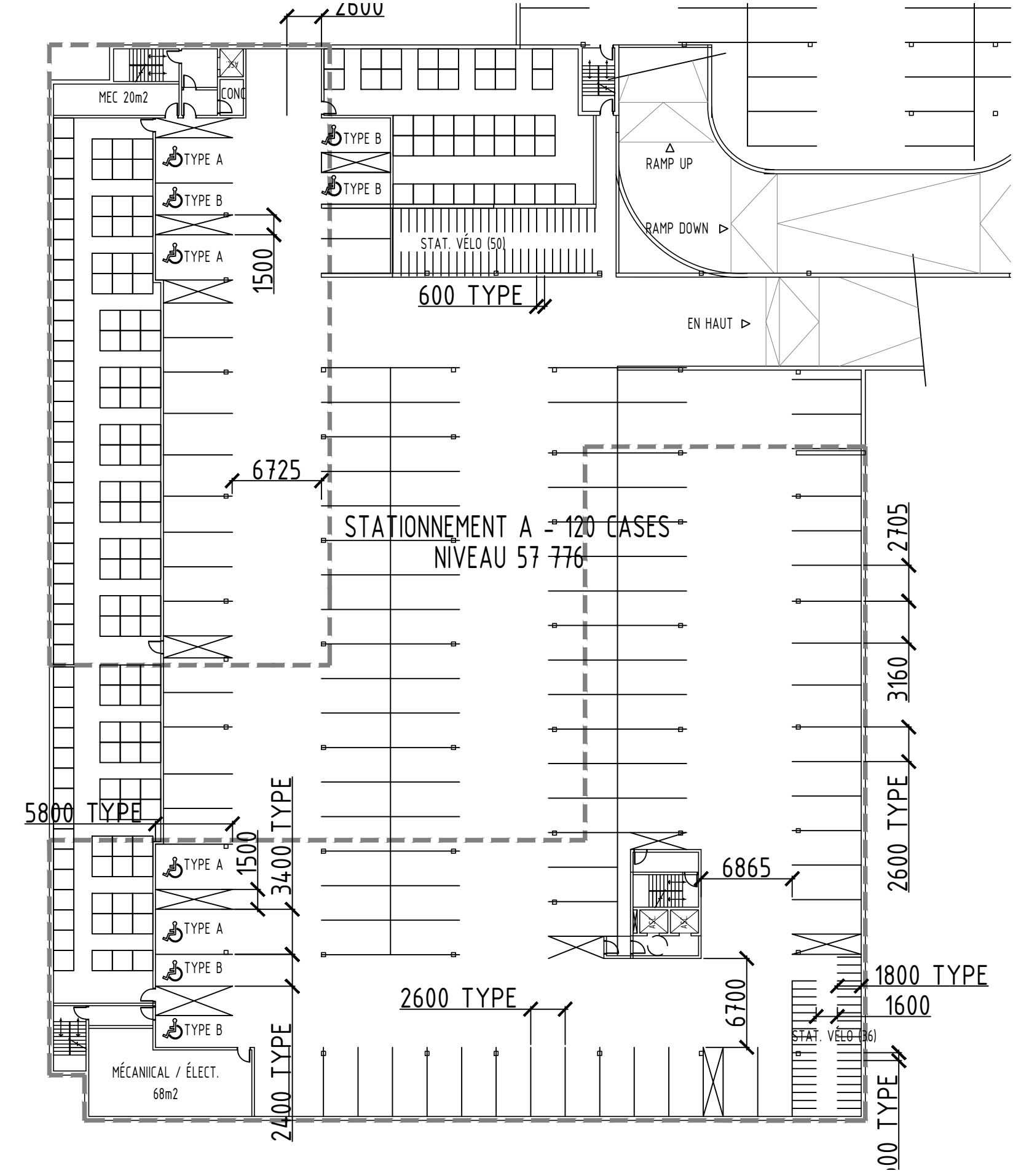

3 PLAN STATIONNEMENT SUD  
A-101 Echelle : 1:350

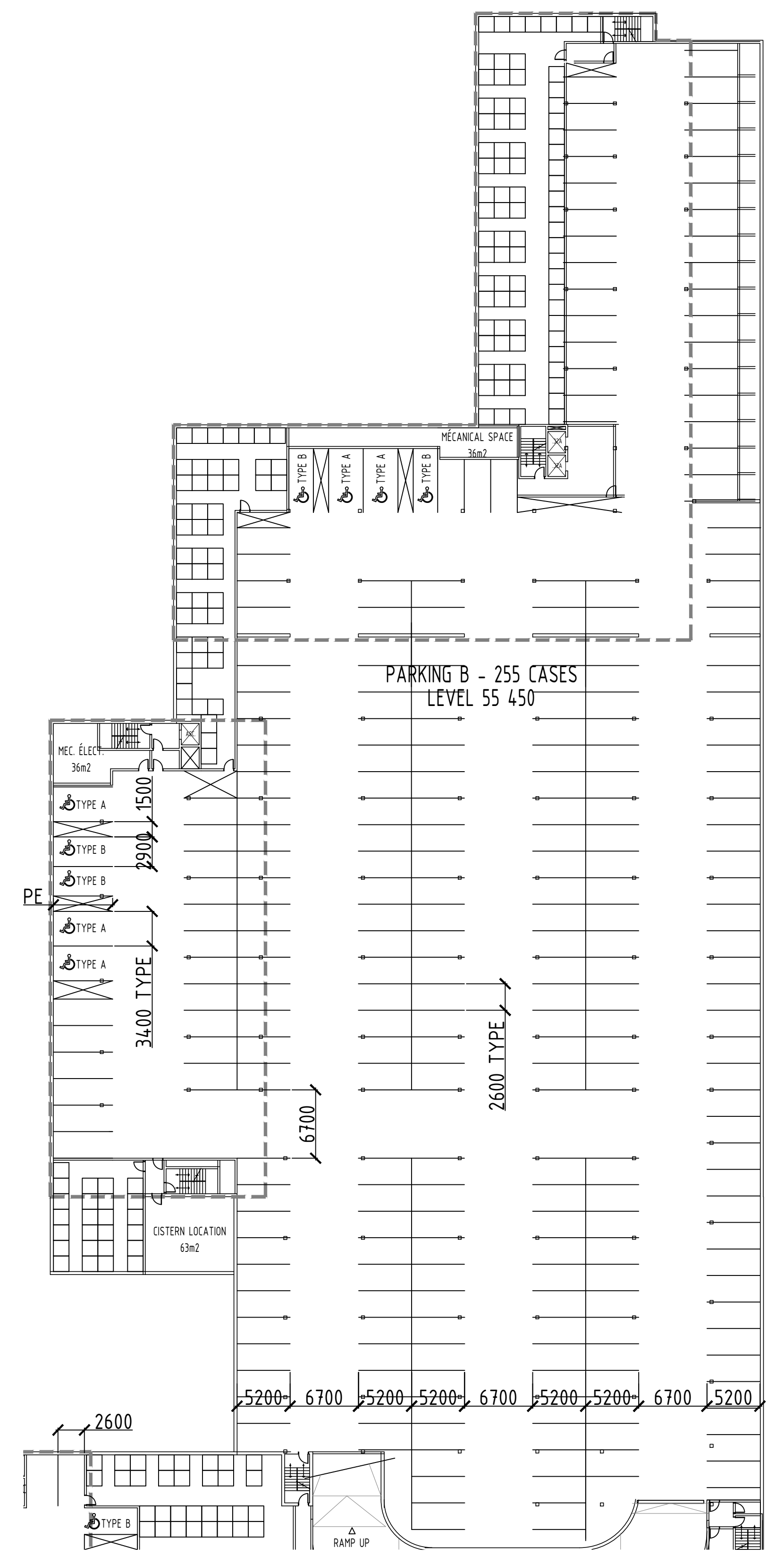

2 PLAN STATIONNEMENT NORD  
A-101 Echelle : 1:350

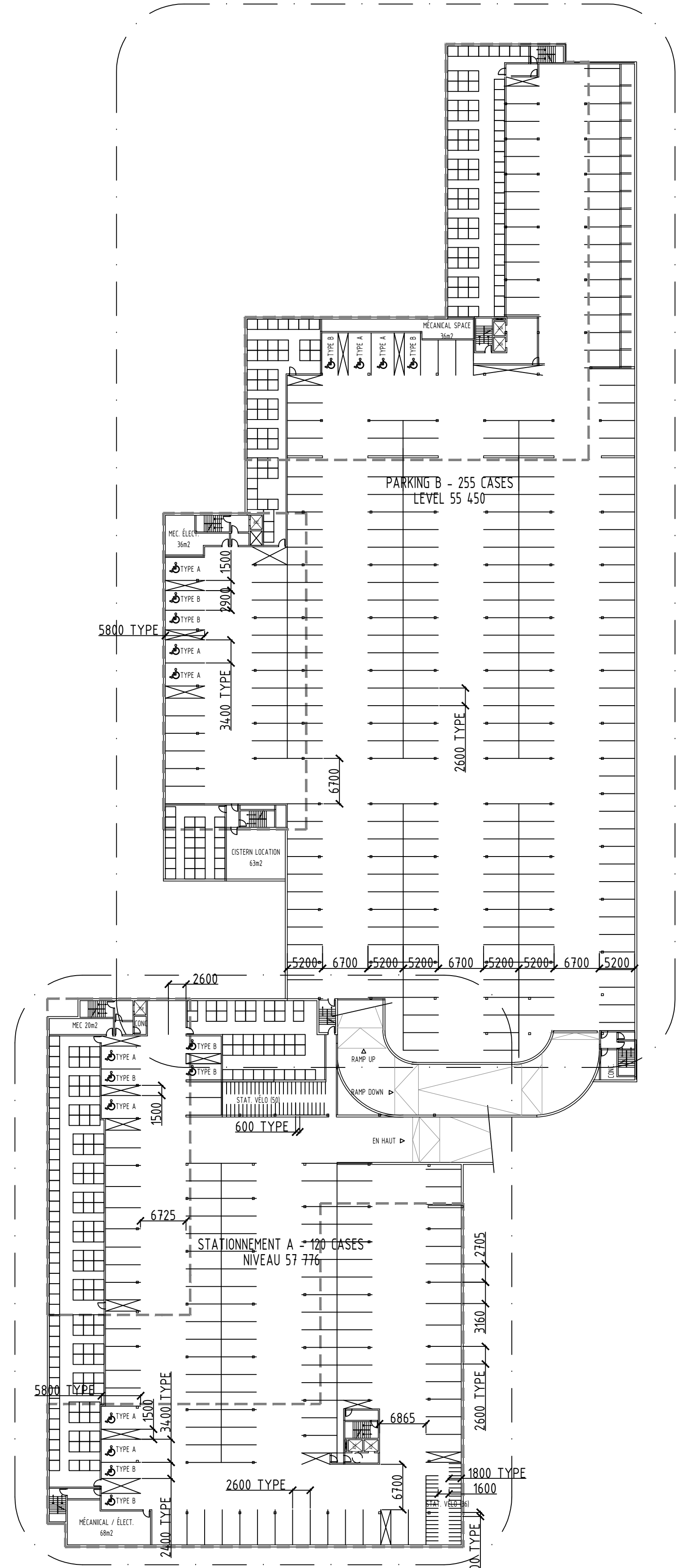

1 UNDERGROUND PARKING LAYOUT  
A-101 Echelle : 1:500







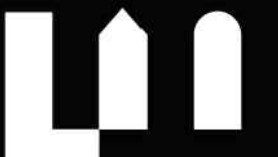

Lemay Michaud

111, rue Saint-Pierre, Québec QC G1K 4A6

**PROJECT**  
MULTI HOUSING - ORLÉANS  
3479 ST. JOSEPH BOULEVARD  
OTTAWA, QC

**CLIENT**  
ISABEL CHARBONNEAU  
PAUL-ANDRÉ CHARBONNEAU

**CONSULTANT**

**PLANS  
BUILDING A & D**

SCALE :

No	DATE	DESCRIPTION
1	2020-05-10	EMIS POUR COORDINATION
2	2020-05-26	EMIS POUR INFORMATION
3	2020-06-25	EMIS POUR INFORMATION
4	2020-08-30	EMIS POUR INFORMATION
5	2020-08-18	EMIS POUR INFORMATION
6	2022-04-05	EMIS POUR INFORMATION
7	2024-06-26	EMIS POUR INFORMATION
8	2024-12-20	SUBMISSION PHASE 3 CITY - V2

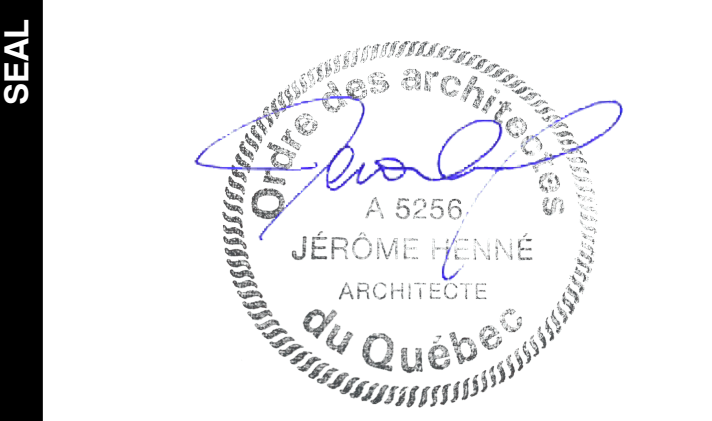

**NOTES**  
IT IS THE CONTRACTOR'S RESPONSIBILITY TO VERIFY ALL MEASUREMENTS AND DIMENSIONS ON SITE PRIOR TO PROCEEDING WITH THIS WORK.  
THIS DOCUMENT REMAINS THE PROPERTY OF LEMAYMICHAUD ARCHITECTURE DESIGN AND IS TO BE USED ONLY FOR THE SPECIFIC PURPOSE FOR WHICH IT IS INTENDED.

**FOLDER**  
109821B

**PAGE**  
A-105



**1** FIRST FLOOR  
A-105  
Echelle : 1:125













Lemay Michaud

111, rue Saint-Pierre, Québec QC G1K 4A6

PROJECT  
MULTI HOUSING - ORLÉANS  
3479 ST. JOSEPH BOULEVARD  
OTTAWA, QC

CLIENT  
ISABEL CHARBONNEAU  
PAUL-ANDRÉ CHARBONNEAU

CONSULTANT

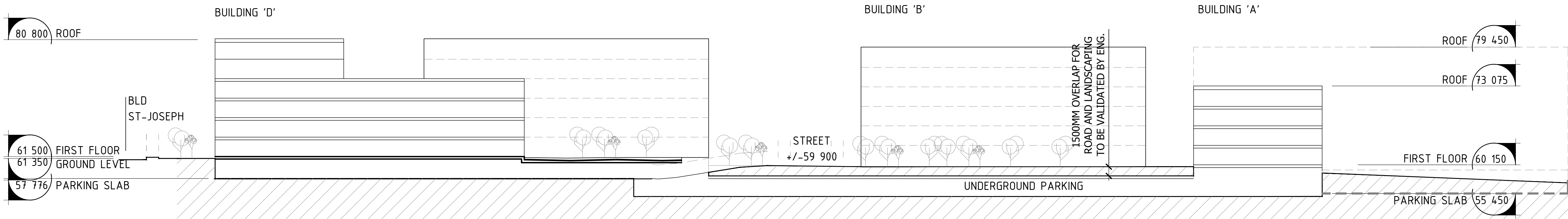

1 SECTION EAST-WEST

Echelle : 1:350

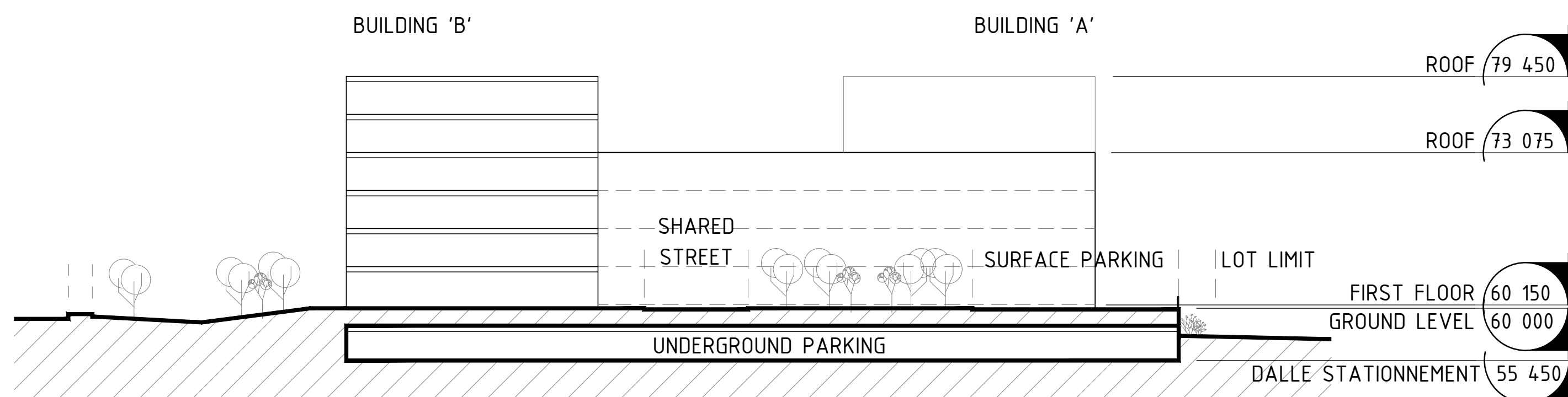

2 SECTION EAST-WEST

Echelle : 1:350

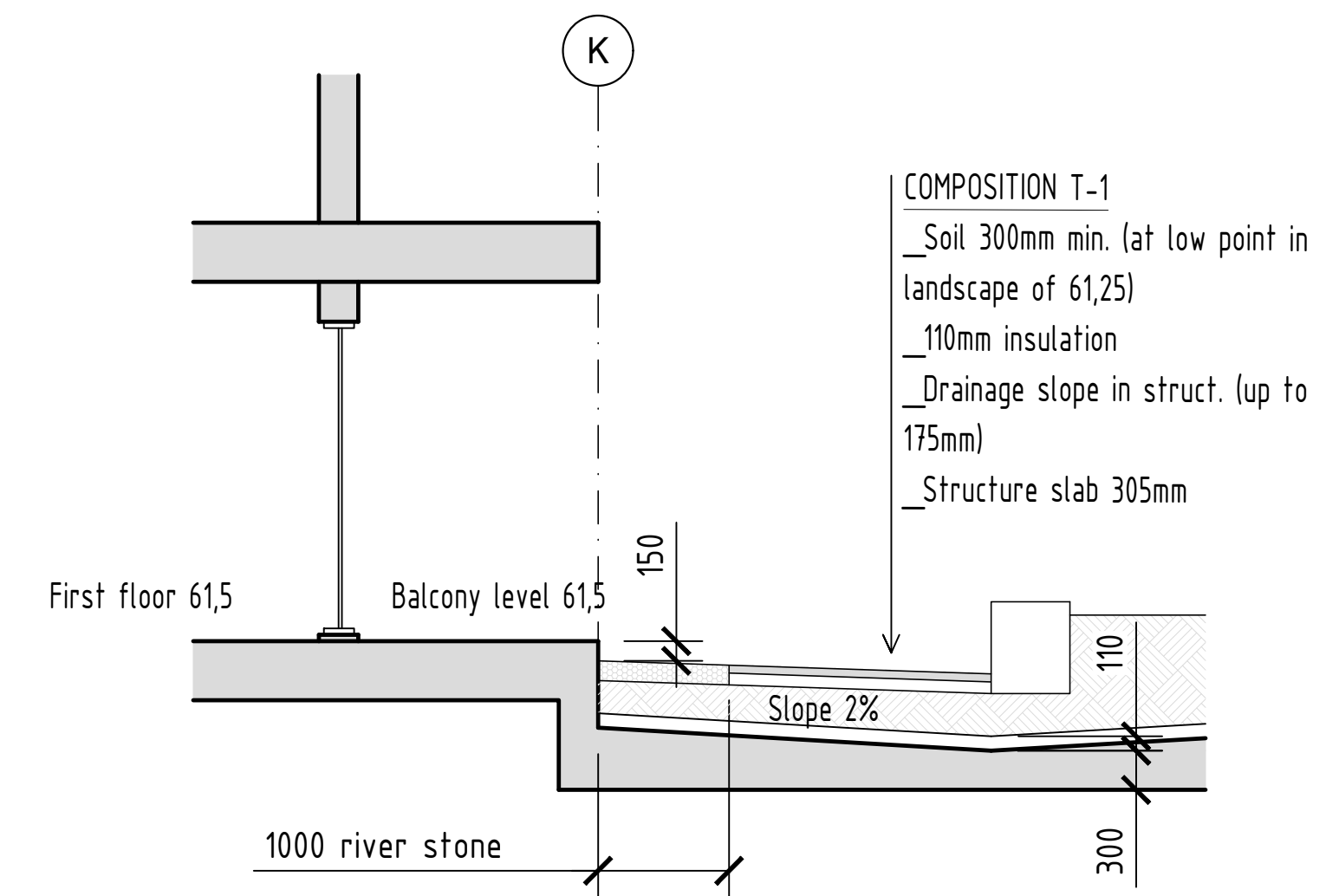

3 SCHEMATIC SECTION GREEN ROOF

Echelle : 1:50

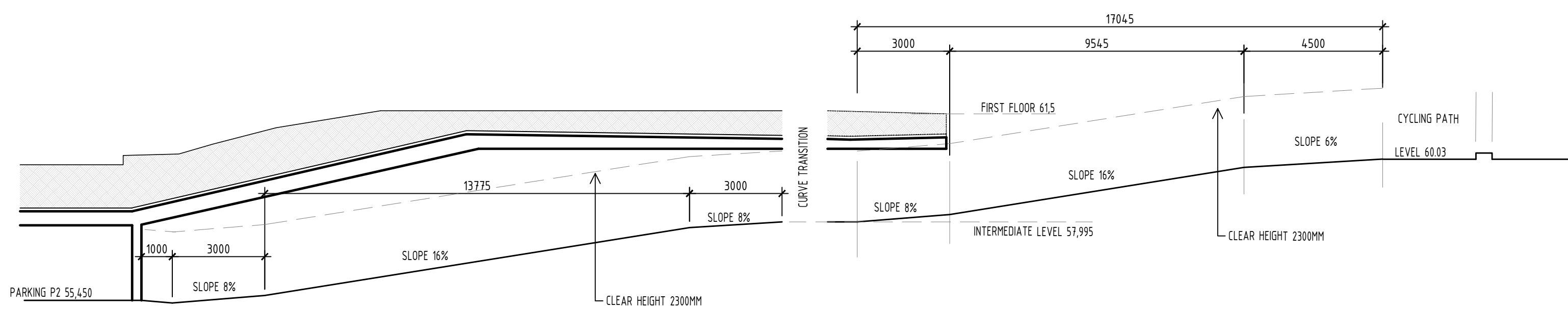

4 RAMP - NORTH ACCESS

Echelle : 1:125

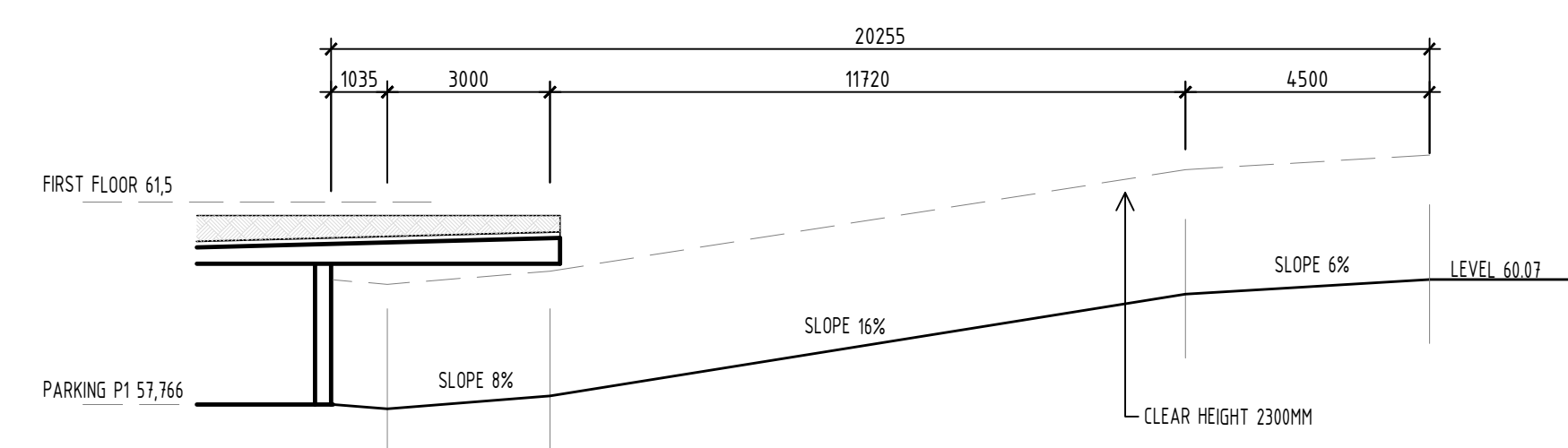

4 RAMP ACCES - EAST

Echelle : 1:125

GENERAL SECTION

SCALE :

No	DATE	DESCRIPTION
6	2022-04-05	ÉMIS POUR INFORMATION
7	2024-05-26	ÉMIS POUR INFORMATION
8	2024-12-20	SUBMISSION PHASE 3 CITY - V2

REVISIONS



SEAL

NOTES  
IT IS THE CONTRACTOR'S RESPONSIBILITY TO VERIFY ALL MEASUREMENTS AND DIMENSIONS ON SITE PRIOR TO PROCEEDING WITH THIS WORK.  
THIS DOCUMENT REMAINS THE PROPERTY OF LEMAYMICHAUD ARCHITECTURE DESIGN AND IS TO BE USED ONLY FOR THE SPECIFIC PURPOSE FOR WHICH IT IS INTENDED.

FOLDER  
109821B

PAGE  
A-310