

**JOHN SEVIGNY C.E.T.**  
**MANAGER (A), DEVELOPMENT REVIEW EAST PLANNING, DEVELOPMENT & BUILDING SERVICES DEPARTMENT, CITY OF OTTAWA**

**APPROVED**  
 By sevignyjo at 10:14 am, Jan 09, 2025

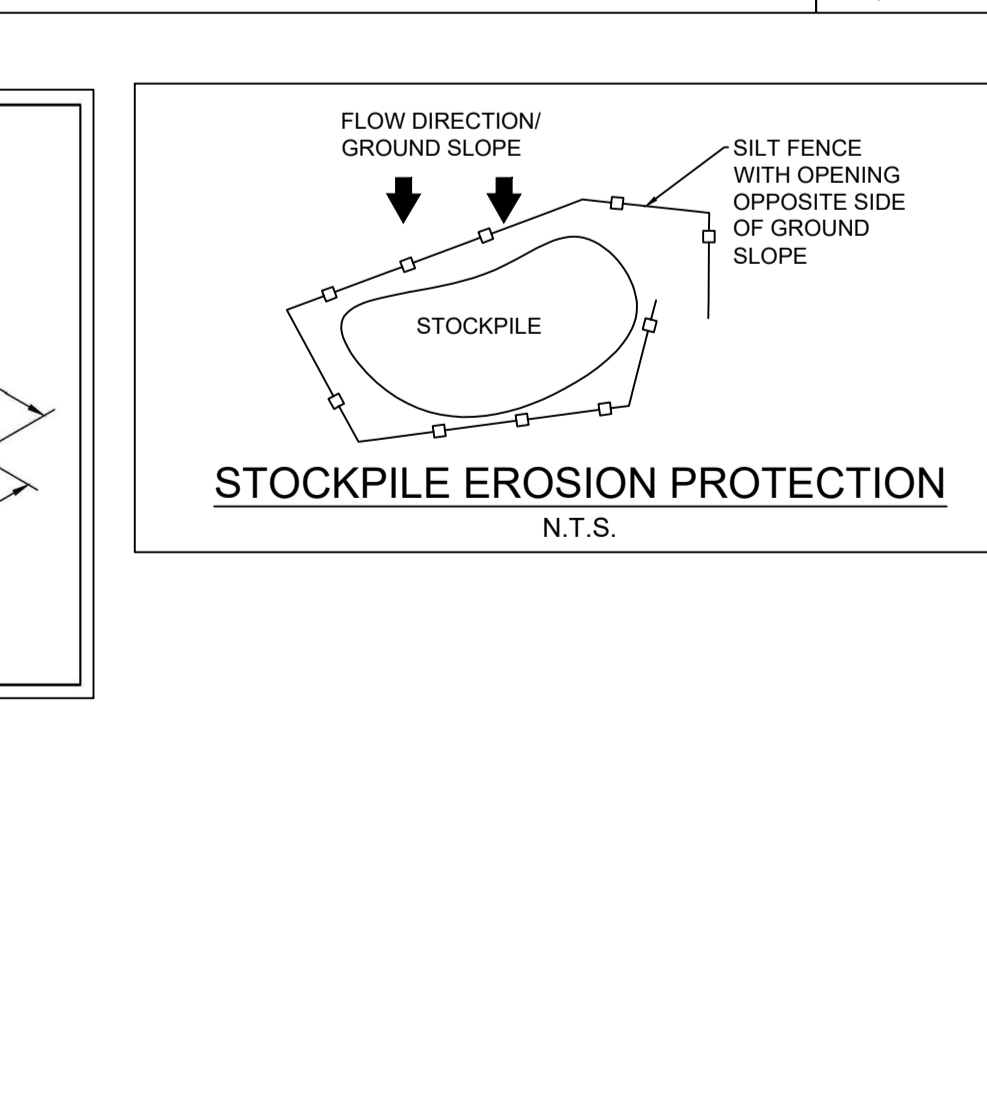
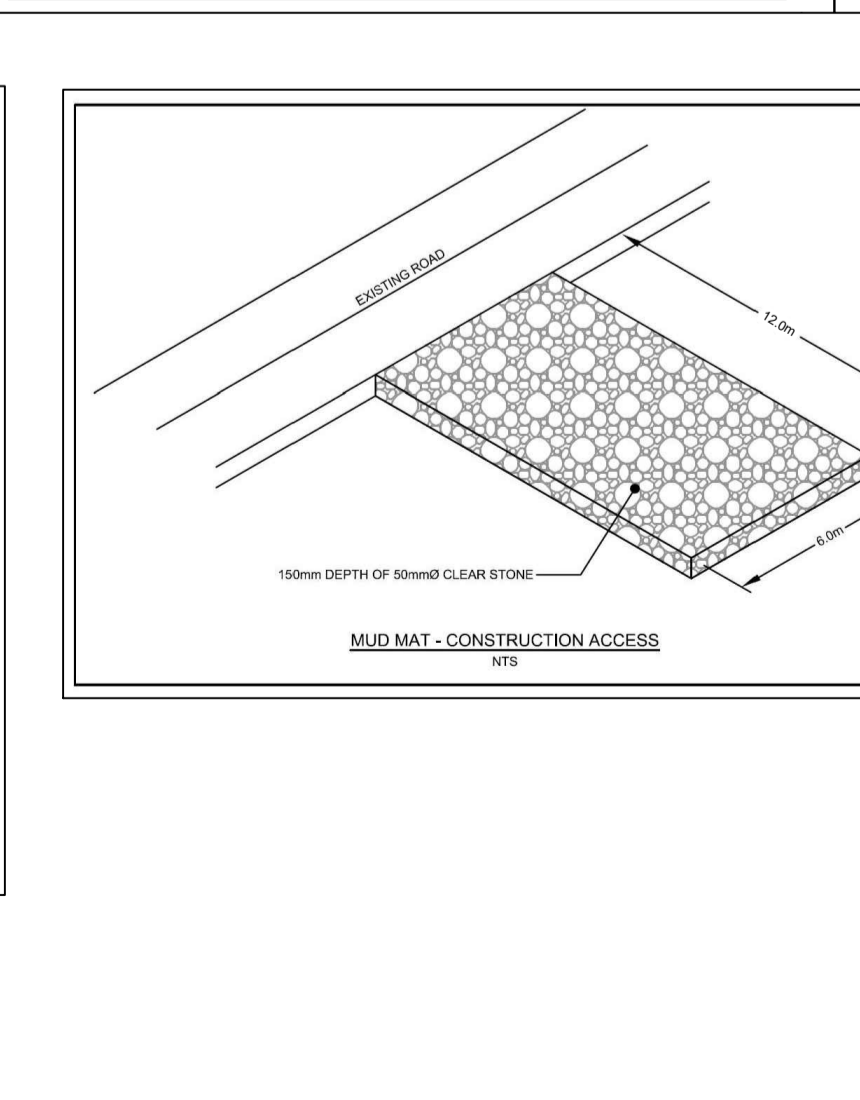
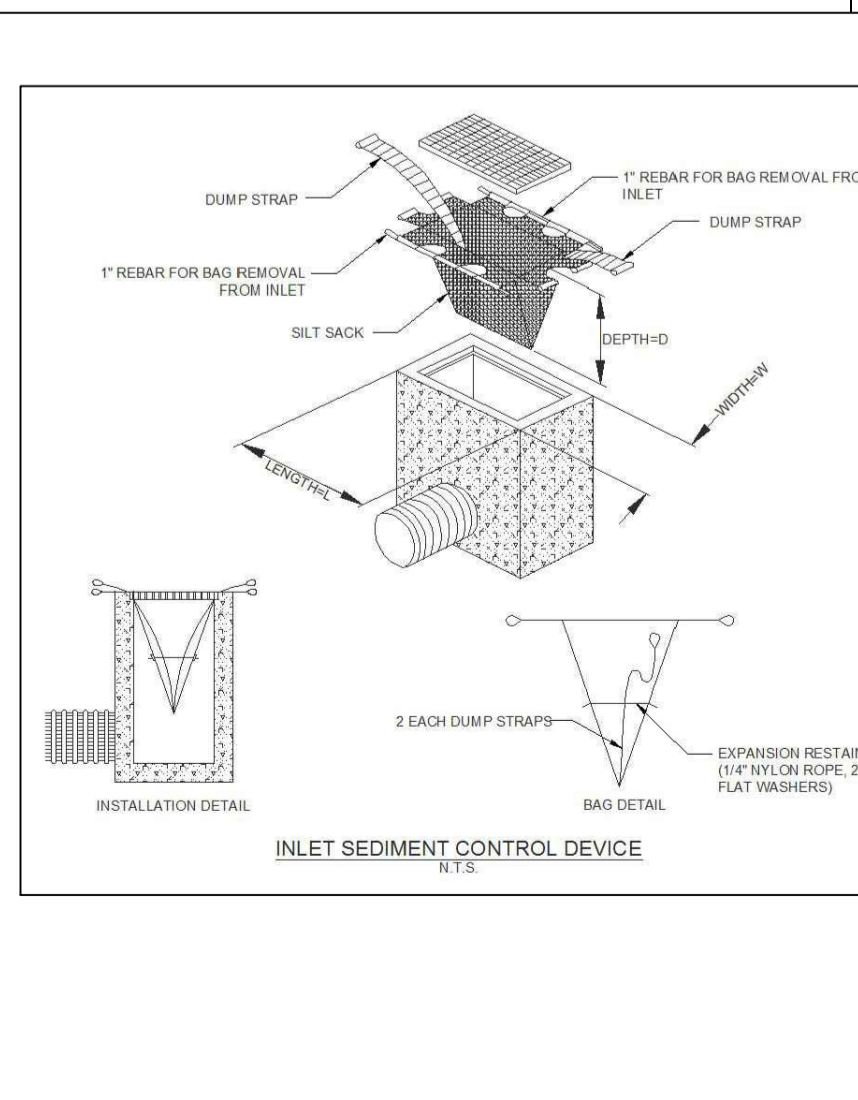
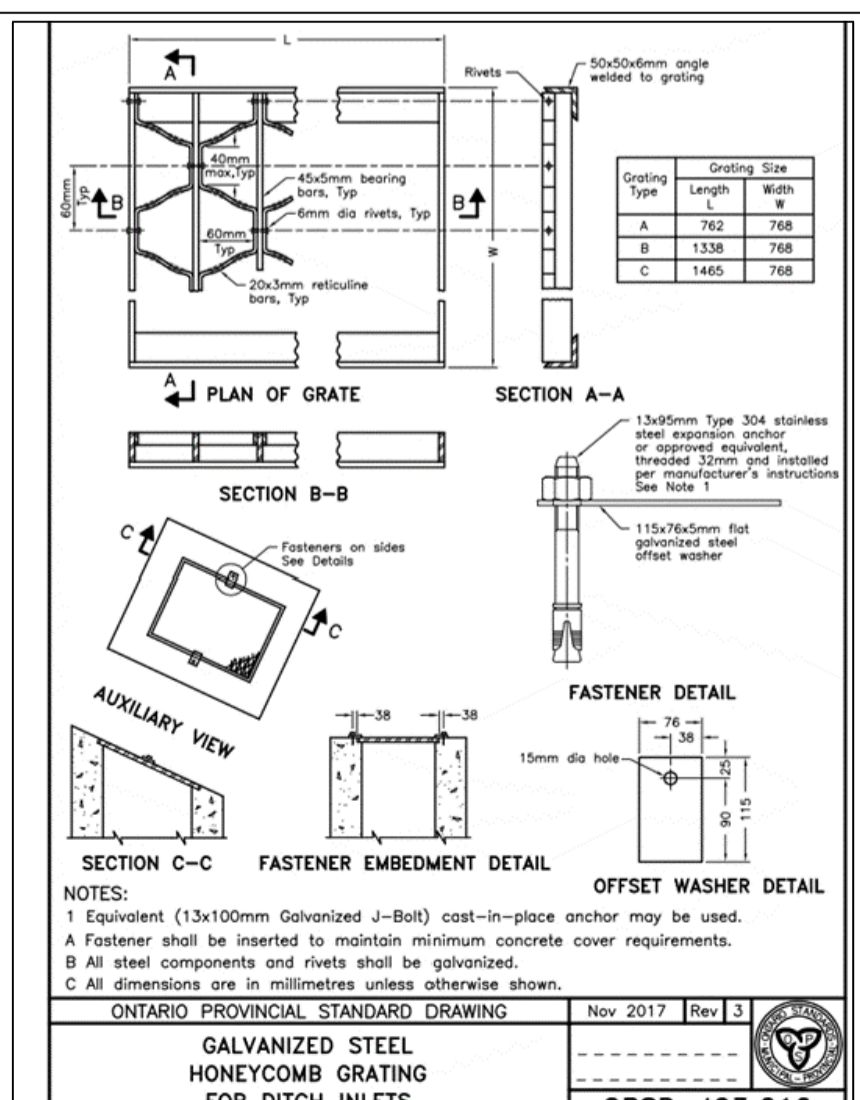
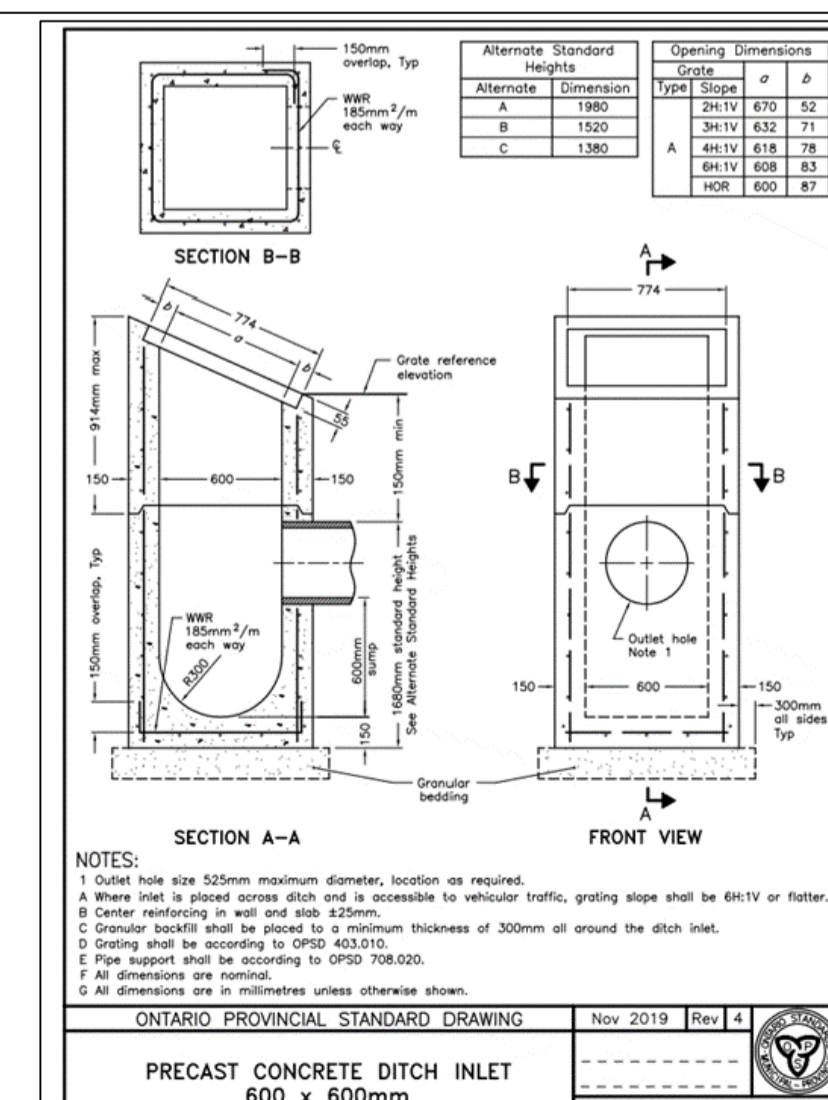
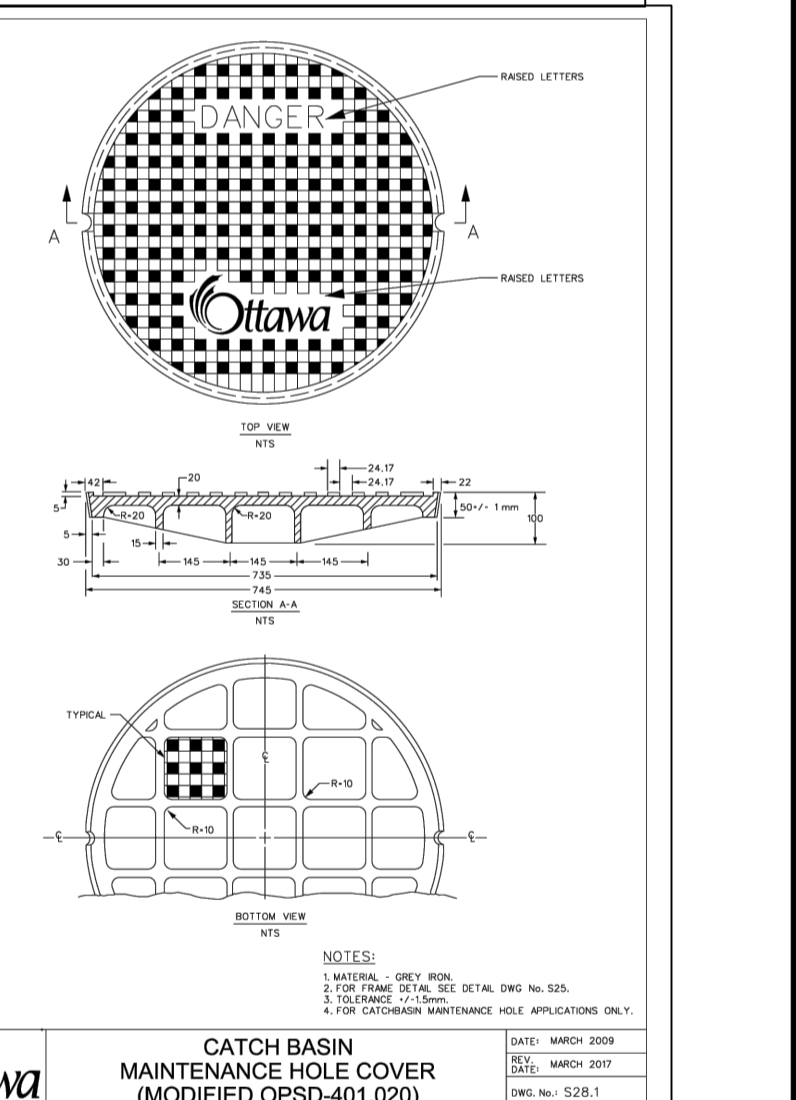
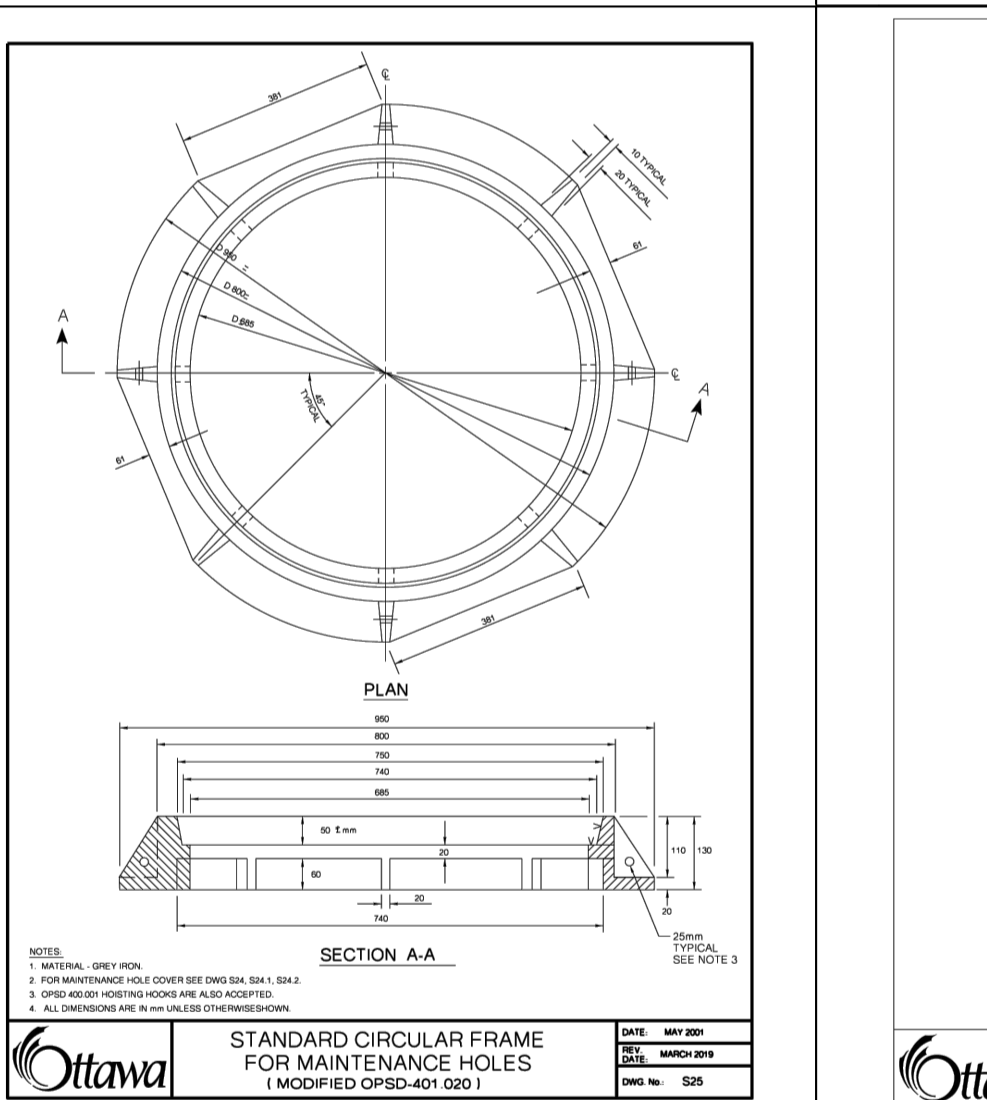
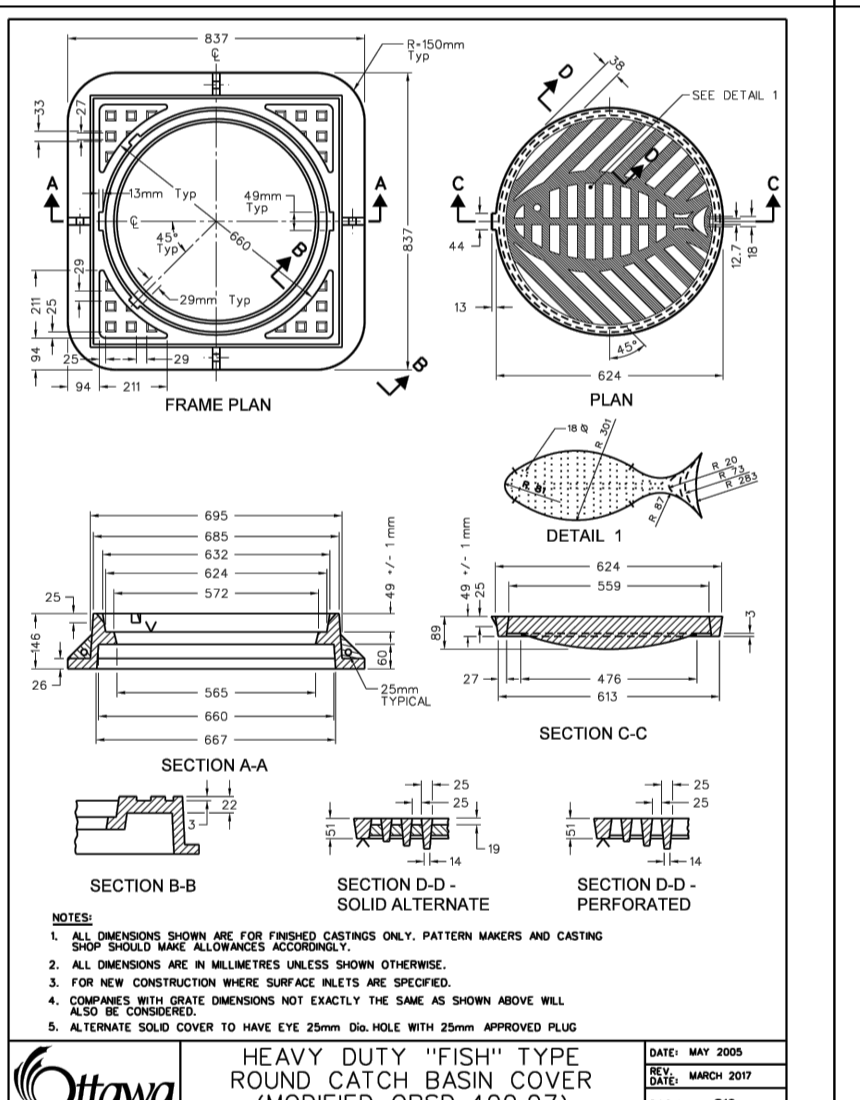
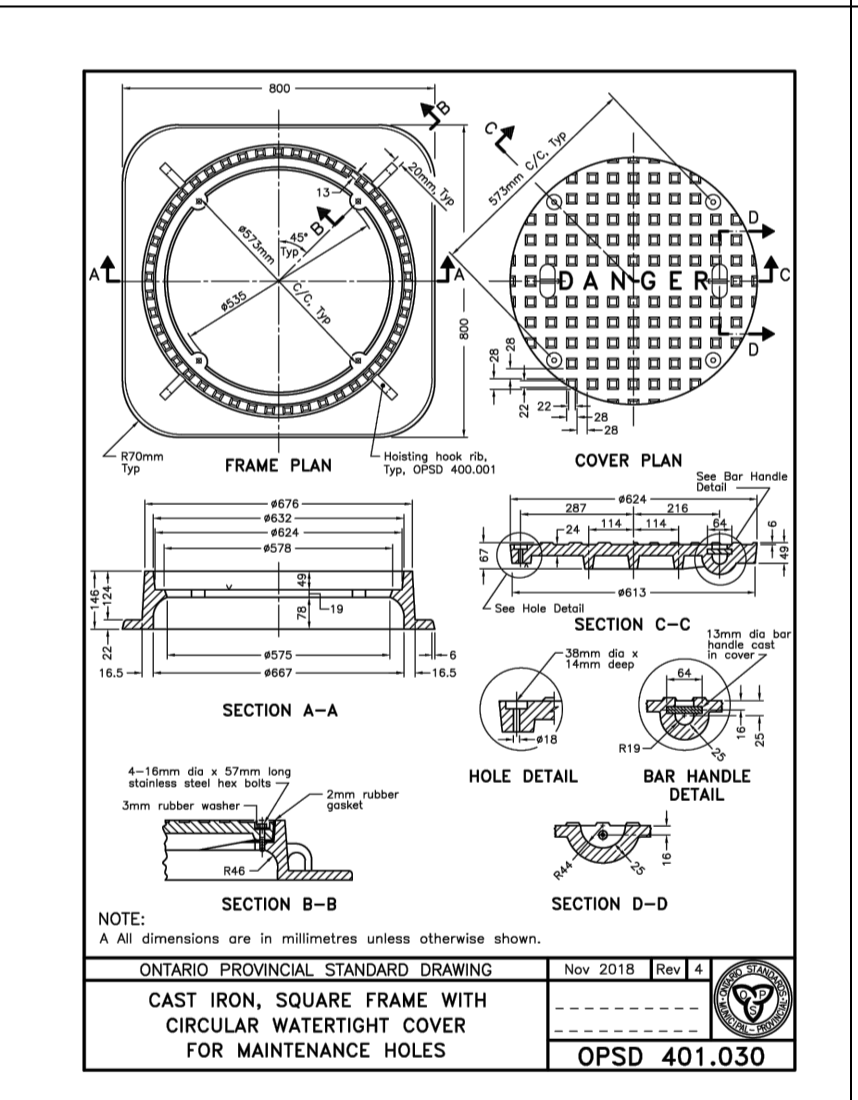
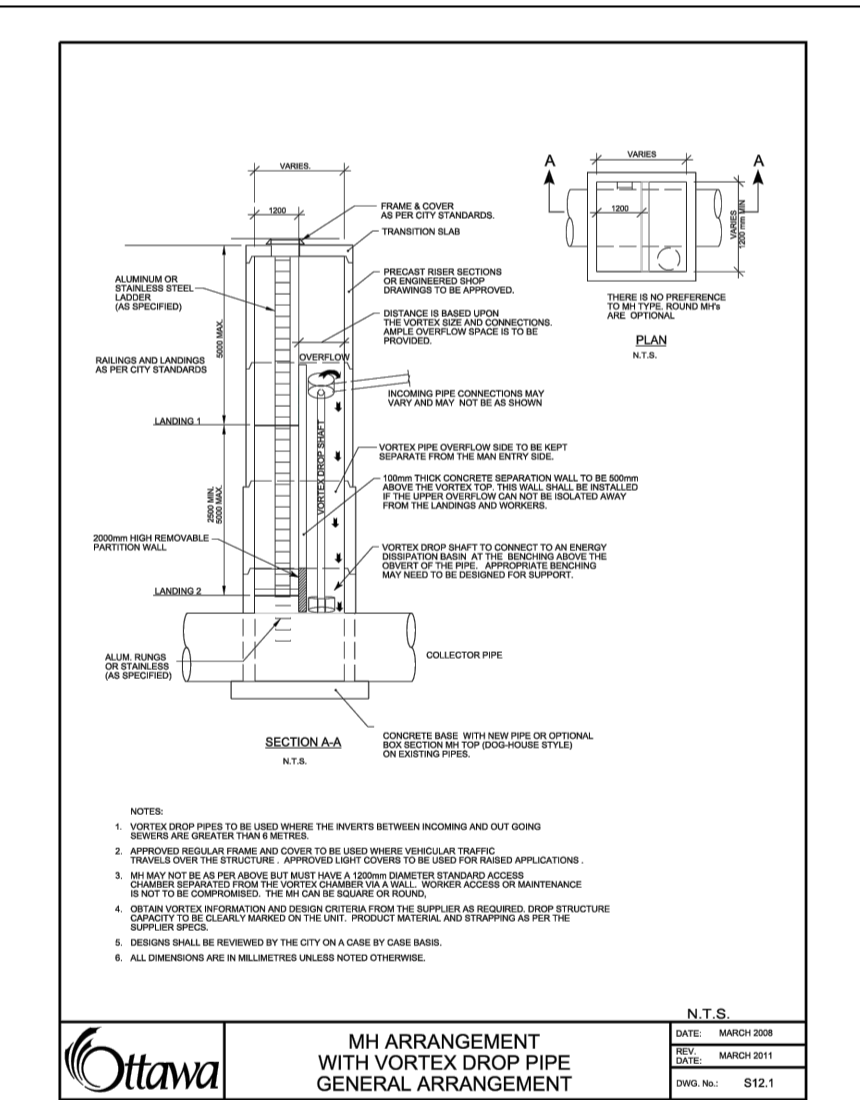
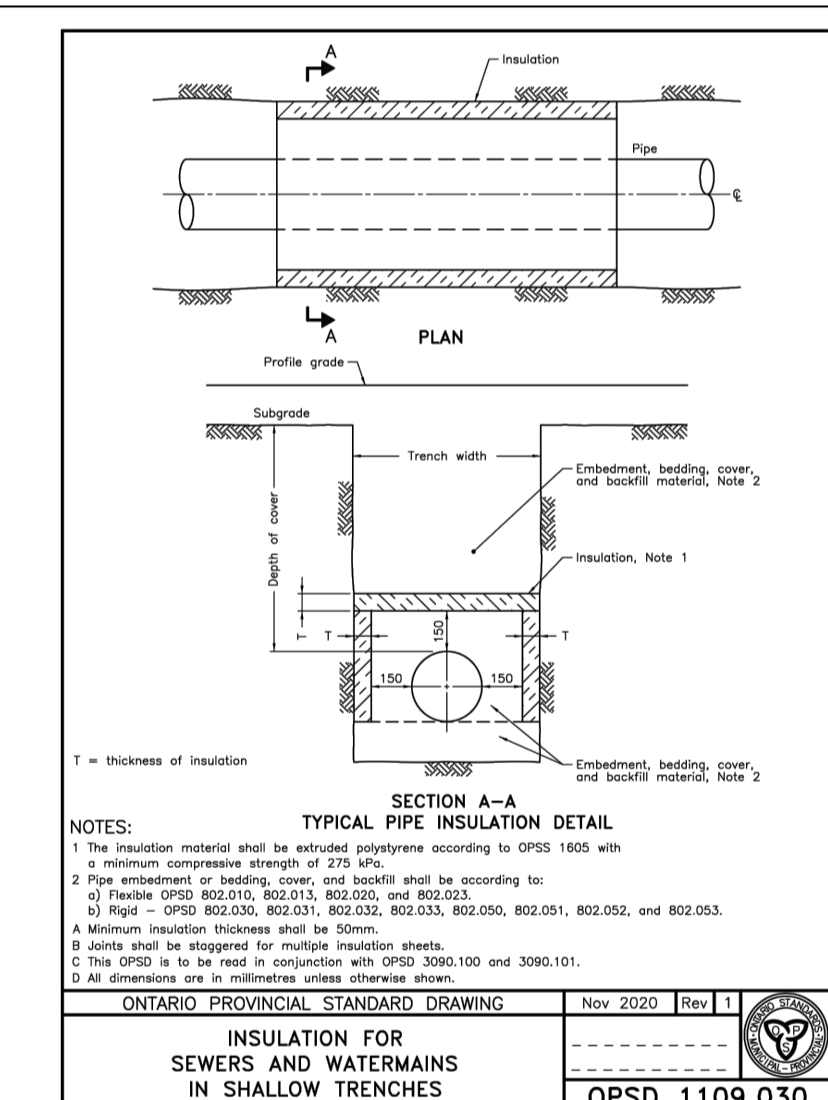
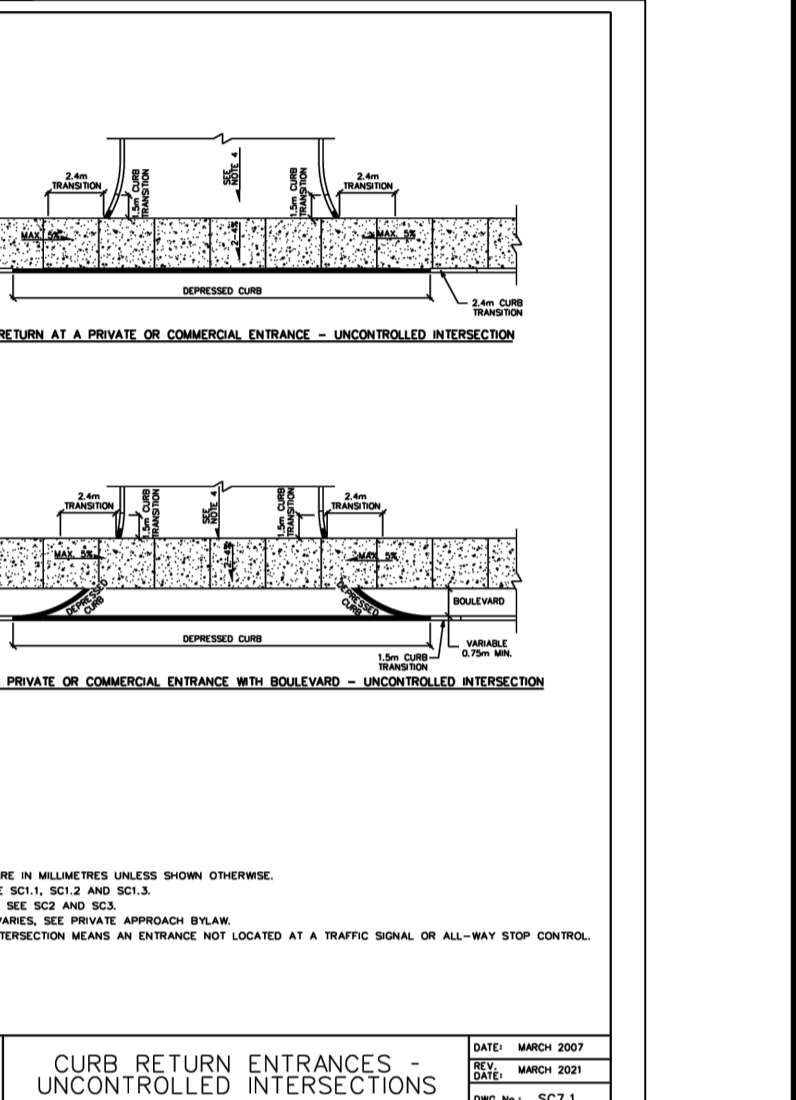
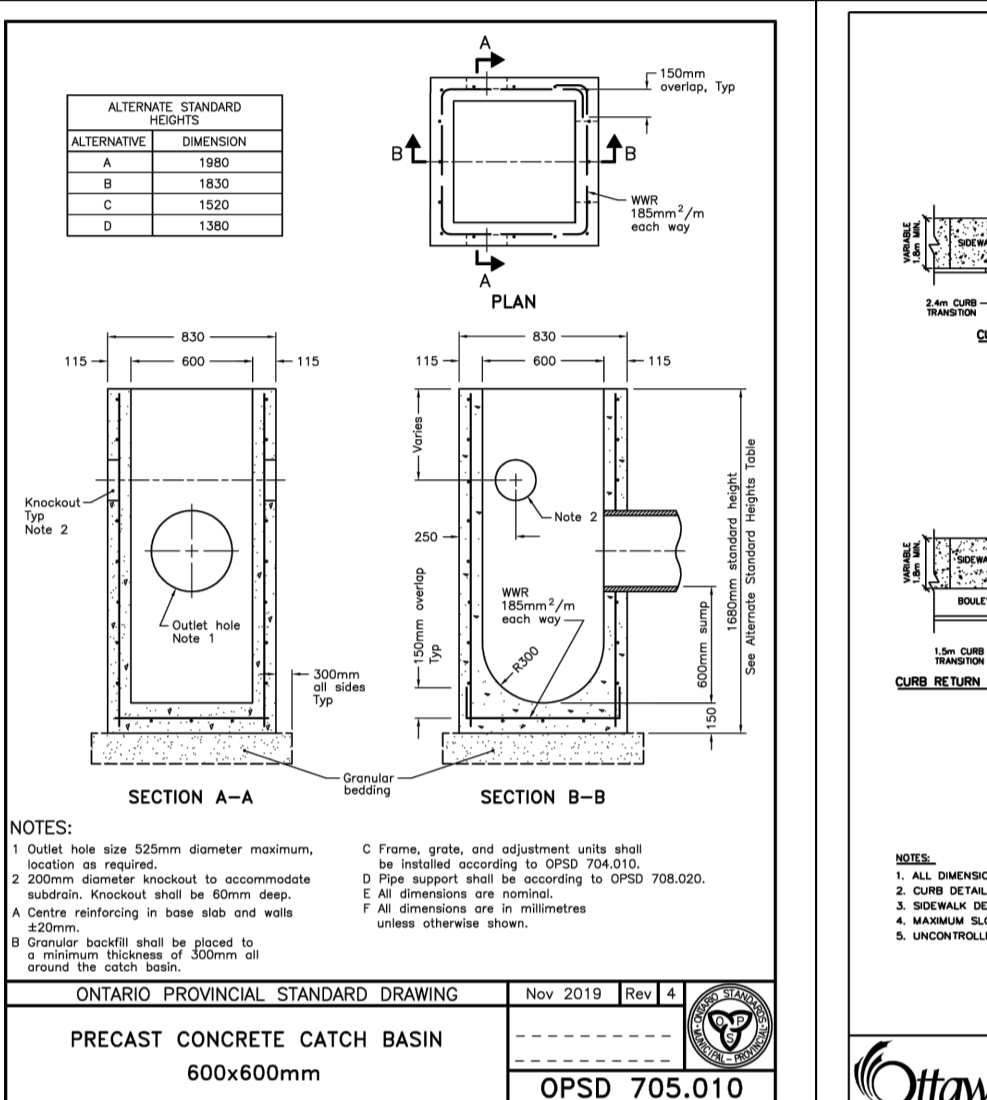
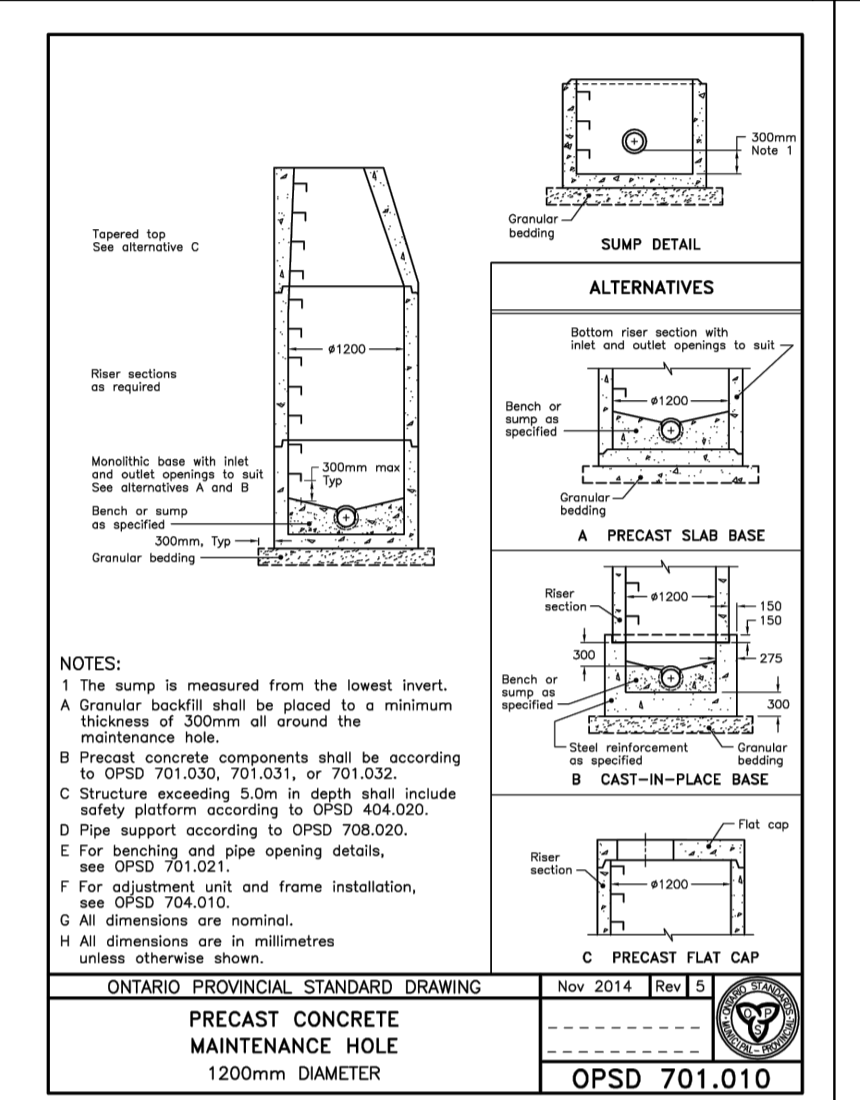
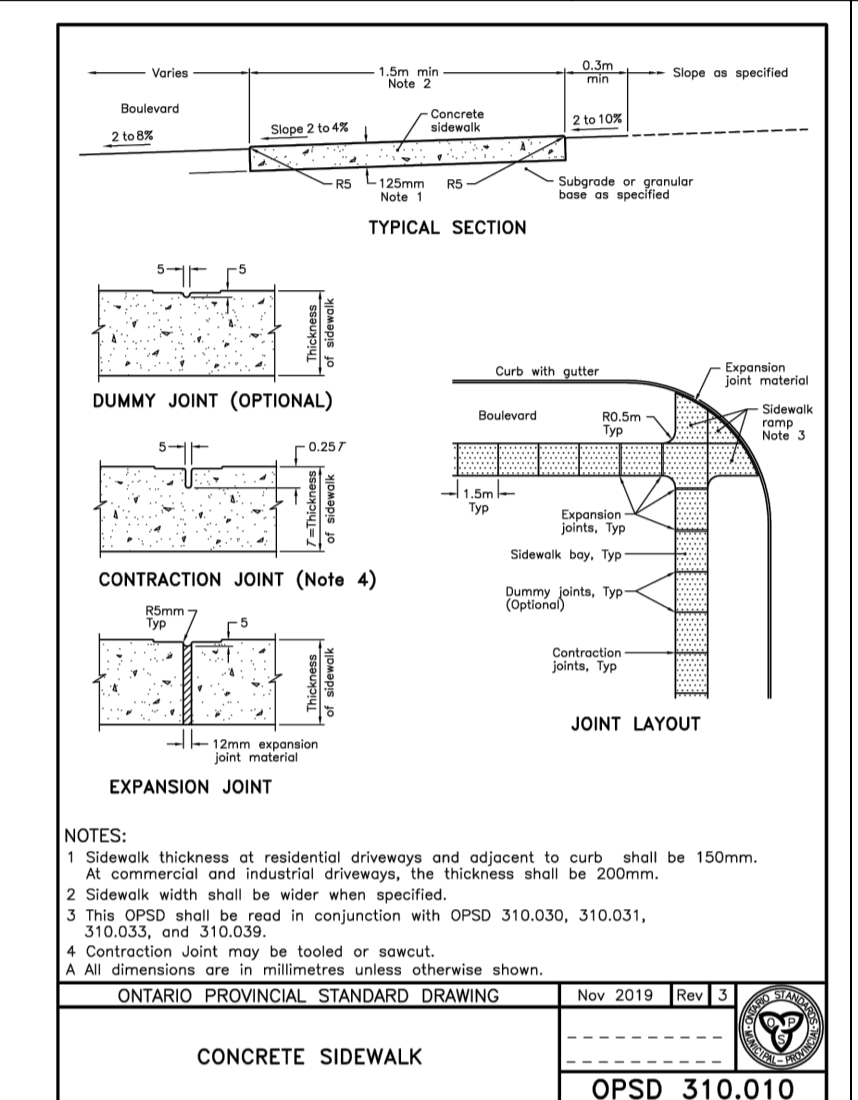
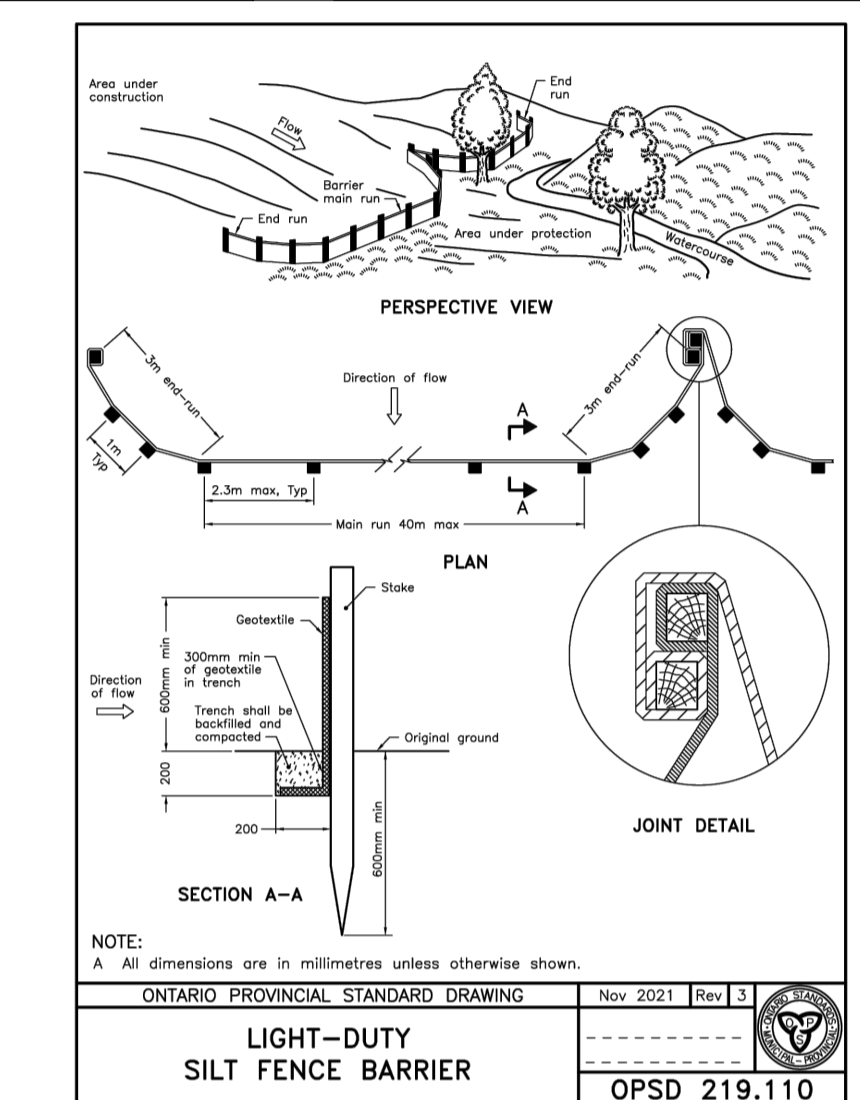
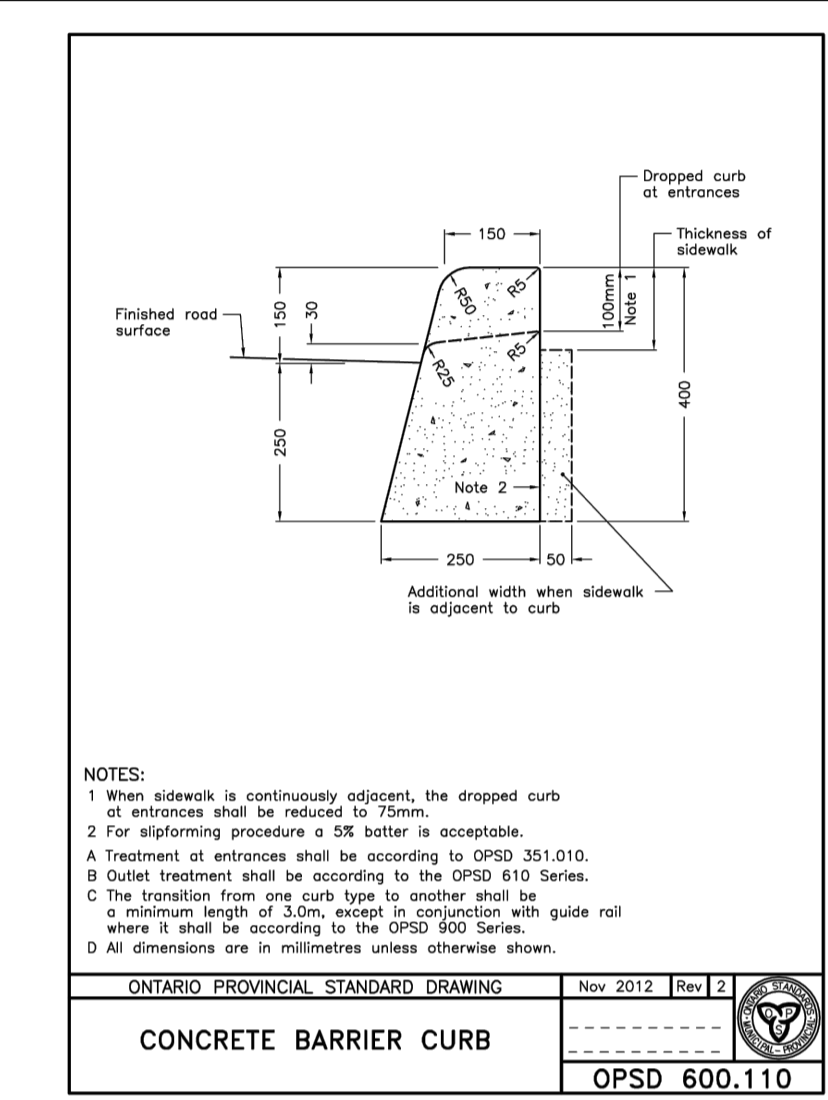

**SUBJECT FOR APPROVAL**

No.	REVISIONS	BY	DATE
09	ISSUED FOR APPROVAL	M.L.	17 DEC 2024
08	ISSUED FOR APPROVAL	M.L.	24 OCT 2024
07	ISSUED FOR APPROVAL	M.L.	11 OCT 2024
06	ISSUED FOR APPROVAL	M.L.	08 AUG 2024
05	ISSUED FOR APPROVAL	S.V.	30 JUL 2024
04	ISSUED FOR APPROVAL	M.L.	28 JUN 2024
03	ISSUED FOR APPROVAL	M.L.	29 JAN 2024
02	ISSUED FOR APPROVAL	M.L.	25 OCT 2023
01	ISSUED FOR COORDINATION	M.L.	06 OCT 2023

**NOT AUTHENTIC UNLESS SIGNED AND DATED**

**PROFESSIONAL ENGINEER**  
 M. BASNET  
 100501996  
 PROVINCE OF ONTARIO

**LRL**  
 ENGINEERING | INGENIERIE  
 5430 Canotek Road | Ottawa, ON, K1J 9G2  
 www.lrl.ca | (613) 842-3434

**CLIENT**  
 TRIM WORKS DEVELOPMENT LTD

**DESIGNED BY:** M.L.     **DRAWN BY:** M.L.     **APPROVED BY:** M.B.

**PROJECT**  
 PLAZA TRIM ROAD DEVELOPMENT  
 1280 TRIM RD,  
 OTTAWA, ON

**DRAWING TITLE**  
 CONSTRUCTION DETAIL PLAN

**PROJECT NO.** 230202     **DATE** APRIL 2023

**C901**