

# 384 ARLINGTON AVE

## Location

OTTAWA, ON

ISSUED FOR SPC FORMAL REV 1

## Key Plan

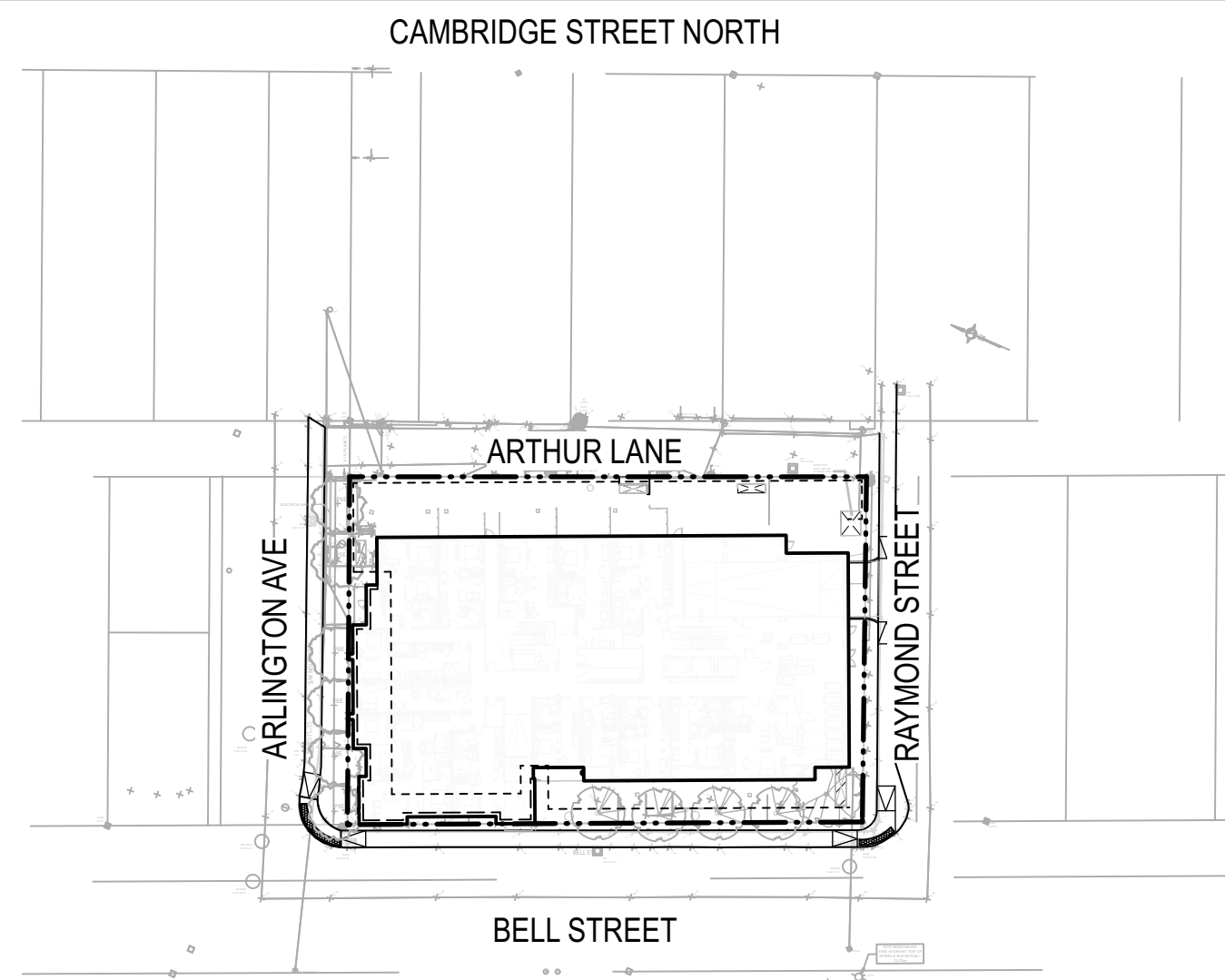

## Project Team

### CONSULTANT TEAM

ARCHITECTS      NEUF  
 PLANNER        FOTENN  
 CIVIL ENGINEER   CIMA+

## General Notes

1. EXISTING CONDITIONS ARE FROM TOPOGRAPHIC SURVEY BY (STANTEC, JUNE 16, 2022).
2. REFER TO ARCHITECTURAL DRAWINGS FOR BUILDING INFORMATION, AND TO ENGINEERING DRAWINGS FOR SERVICES, GRADING, STRUCTURAL, AND MECHANICAL INFORMATION.
3. CONTRACTOR SHALL REVIEW ALL DRAWINGS AND SPECIFICATIONS TO DETERMINE THE REQUIRED SCOPE OF WORK AND ALL REQUIRED COORDINATION.
4. CONTRACTOR IS RESPONSIBLE FOR A THOROUGH SITE EXAMINATION TO CONFIRM THE ACTUAL SITE CONDITIONS PRIOR TO SUBMISSION OF BIDS OR COMMENCING WORK.
5. CONTRACTOR SHALL VERIFY ALL EXISTING UTILITY LOCATIONS PRIOR TO EXCAVATION AND COMMENCING WORK.
6. ALL PROPOSED WORK LINES ARE PARALLEL OR PERPENDICULAR TO THE LINES FROM WHICH THEY ARE MEASURED, UNLESS OTHERWISE NOTED.
7. CONTRACTOR SHALL BE RESPONSIBLE FOR DOCUMENTING THE LOCATIONS OF ALL SITE ELEMENTS TO BE RESET IN THEIR SAME LOCATION.
8. ANY AREA OUTSIDE OF THE LIMIT OF WORK THAT IS DISTURBED SHALL BE RESTORED TO ITS ORIGINAL CONDITION BY THE CONTRACTOR, AT NO COST TO THE OWNER.
9. REQUIRED SHOP DRAWINGS SHALL BE BASED ON FIELD MEASUREMENT AND LAYOUT VERIFICATION BY THE CONTRACTOR.
10. WHERE APPLICABLE, THE LIMIT OF WORK LINE IS THE FACE OF THE BUILDING AND THE PROPERTY LINE, OR AS OTHERWISE NOTED ON THE DRAWINGS.
11. ALL LINE AND GRADE WORK PER DRAWINGS AND SPECIFICATIONS SHALL BE LAID OUT BY A REGISTERED CIVIL ENGINEER OR SURVEYOR ENGAGED BY THE GENERAL CONTRACTOR.
12. STORAGE AREAS FOR CONTRACTOR'S EQUIPMENT AND MATERIALS SHALL BE WITHIN THE LIMIT OF WORK AS SHOWN ON THE PLAN.
13. CONTRACTOR TO PROTECT ALL TREES FROM DAMAGE (THE CANOPY, TRUNK, AND ROOT ZONE AREAS) AS REQUIRED BY LOCAL GOVERNMENT REGULATIONS, AND TO THE SATISFACTION OF THE LANDSCAPE ARCHITECT.
14. ALL LAYOUTS FOR WALKS AND PATHS SHALL BE ADEQUATELY STAKED BY THE CONTRACTOR AND APPROVED BY THE LANDSCAPE ARCHITECT PRIOR TO CONSTRUCTION.
15. WHERE NEW PAVING OR EARTHWORK MEETS EXISTING PAVING OR EARTHWORK, CONTRACTOR IS TO SMOOTHLY BLEND THE LINE AND GRADE OF EXISTING WITH NEW.
16. DIMENSIONS ON ROADS AND SIDEWALKS ARE FROM FACE OF CURB UNLESS OTHERWISE NOTED ON DRAWINGS. DIMENSIONS TO SITE FROM BUILDING ARE FROM THE OUTSIDE (EXPOSED) FACE OF WALL, UNLESS OTHERWISE NOTED.
17. EXPANSION JOINT FILLER SHALL BE PLACED WHERE PAVEMENT MEETS STRUCTURES, INCLUDING WALLS, LIGHT POLES, HYDRANTS, BUILDINGS, AND BUILDING COLUMNS, STAIRS, AND AT OTHER LOCATIONS SHOWN ON THE DRAWINGS. CONTRACTOR SHALL REQUEST THE PRESENCE OF THE LANDSCAPE ARCHITECT TO REVIEW THE LAYOUT OF EXPANSION JOINTS AND CONTROL JOINTS PRIOR TO PLACING FINISHED WORK.
18. EXCAVATION REQUIRED WITHIN PROXIMITY OF UTILITY LINES AND WITHIN DRIFLINE OF TREES DESIGNATED TO REMAIN SHALL BE DONE BY HAND. CONTRACTOR SHALL REPAIR ANY DAMAGE TO EXISTING UTILITY LINES OR STRUCTURES INCURRED DURING CONSTRUCTION OPERATIONS, AT NO COST TO THE UTILITY COMPANIES OR THE OWNER.
19. ALL POINTS OF CONSTRUCTION EGRESS OR INGRESS SHALL BE MAINTAINED TO PREVENT TRACKING OR FLOWING OF SEDIMENT ONTO PUBLIC ROADS OR ABUTTING PROPERTY.

## Sheet #

## Sheet Title

L0.1	SOIL VOLUME PLAN
L1.1	LANDSCAPE PLAN - GROUND FLOOR
L1.2	LANDSCAPE PLAN - 4TH FLOOR
L1.3	LANDSCAPE PLAN - 7TH FLOOR
L2	LANDSCAPE DETAILS
L3	LANDSCAPE DETAILS
L4	PLANTING DETAILS

10		
9		
8		
7		
6		
5		
4	SPC FORMAL SUBMISSION REV 1	2024-12-04
3	ISSUED FOR SPC FORMAL SUBMISSION	2024-10-04
2	ISSUED FOR SPA 2	2024-06-06
1	ISSUED FOR SPA	2024-02-09

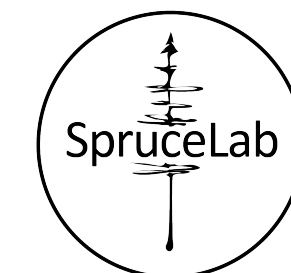
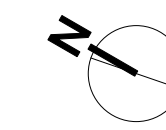

**SpruceLab Inc.**  
 Address: 550 Bayview Ave, Suite 300  
 Toronto, ON, M4W 3X8  
 Telephone: (647) 899-5891  
 www.sprucelab.ca

Note:  
 All drawing information shall be checked and verified and any discrepancies reported in writing to the Landscape Architect before commencing any affected work. This drawing shall be used only for the project named on this drawing and for reference purposes only. This drawing shall not be scaled. This drawing is not for construction unless signed by the Landscape Architect. This drawing and all aspects of its content are the copyright property of SpruceLab. Reproduction in whole or in part, by any means whatsoever, without the express written permission of SpruceLab, is prohibited.

Legal Description: L1s 14 & 15, Pt 33, (S Of Stone Boundary) E Bell St N, Pt L1s 13 & 16, Pt 33, (S Of Stone Boundary) E Bell St N, as in Cr11653, Cr101496, Cr472519 & Cr513256, Ottawa/Nepean

Client

**Windmill Developments**  
 Toronto, ON

Project

**384 ARLINGTON AVE**  
 OTTAWA, ON

Property Identification Number: 04105-0128

Drawing Title

**COVER PAGE**

Scale:	NTS	Project #	
Designed By:	SB		0.001
Drawn By:	KG/NS		Drawing #
Approved By:	SB		
Date:	10/13/21		

**L0**

**NOT FOR CONSTRUCTION**

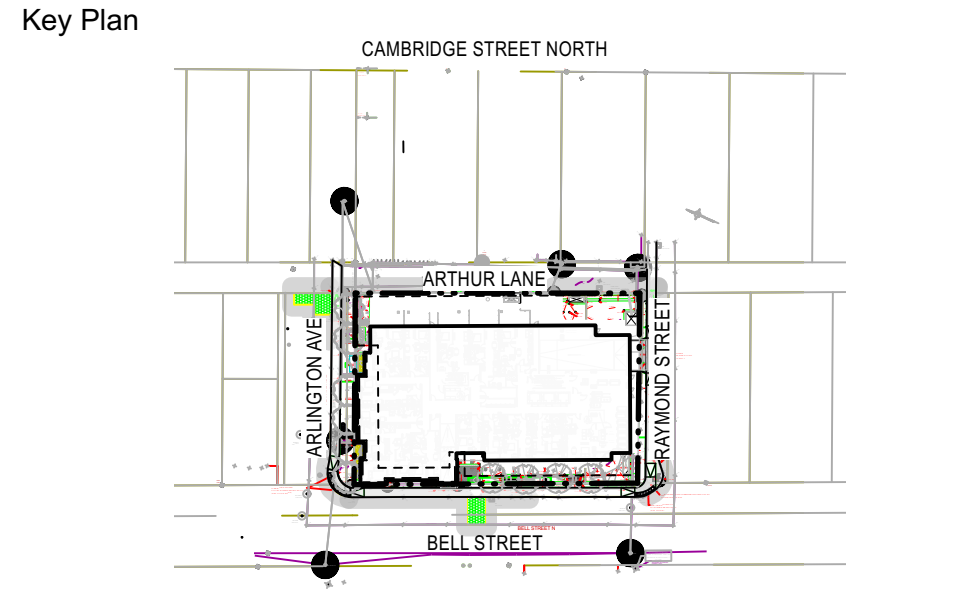
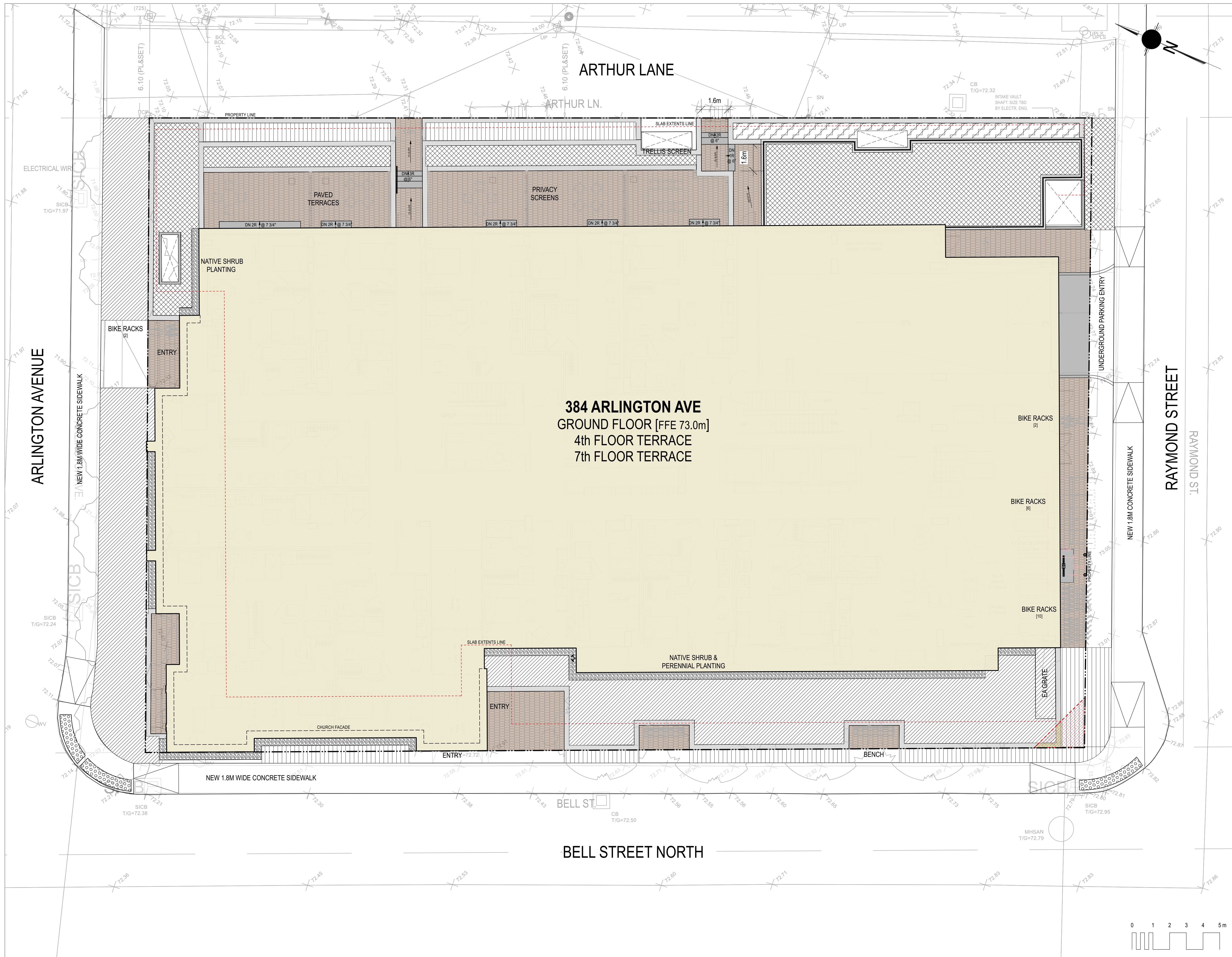

- LEGEND:**
- Property Line
  - Planting (3') DEPTH
  - Concrete Pavers 600mm (2') DEPTH
  - Harvest Table 450mm (1.5') DEPTH
  - BBQ & Prep Counter 200mm (8") DEPTH
  - Bistro Set

10		
9		
8		
7		
6		
5		
4	SPC FORMAL SUBMISSION REV 1	2024-12-04
3	ISSUED FOR SPC FORMAL SUBMISSION	2024-10-04
2	ISSUED FOR SPA 2	2024-06-06
1	ISSUED FOR SPA	2024-02-09

Stamp

**SpruceLab Inc.**  
 Address: 550 Bayview Ave, Suite 300  
 Toronto, ON, M4W 3X8  
 Telephone: (647) 899-5891  
 www.sprucelab.ca

**Note:**  
 All drawing information shall be checked and verified and any discrepancies reported in writing to the Landscape Architect before commencing any affected work. This drawing shall be used only for the project named on this drawing and for reference purposes only. This drawing shall not be scaled. This drawing is not for construction unless signed by the Landscape Architect. This drawing and all aspects of its content are the copyright property of SpruceLab. Reproduction in whole or in part, by any means whatsoever, without the express written permission of SpruceLab, is prohibited.

**Legal Description:** Lts 14 & 15, Pt 33, (S Of Stone Boundary) E Bell St N, Pt Lts 13 & 16, Pt 33, (S Of Stone Boundary) E Bell St N, as in C01653, C101496, C472519 & C513256, Ottawa/Nepean

Client  
**Windmill Developments**  
 Toronto, ON

Project  
**384 ARLINGTON AVE**  
 OTTAWA, ON  
 Property Identification Number: 04105-0128

Drawing Title  
**Soil Depth Plan**

Scale: 1:100  
 Project # 0.001  
 Designed By: SB  
 Drawing # L0.1  
 Drawn By: KG/NS  
 Approved By: SB  
 Date: 10/13/21

**NOT FOR CONSTRUCTION**

File: D07-16-24-017, Plan: 19189

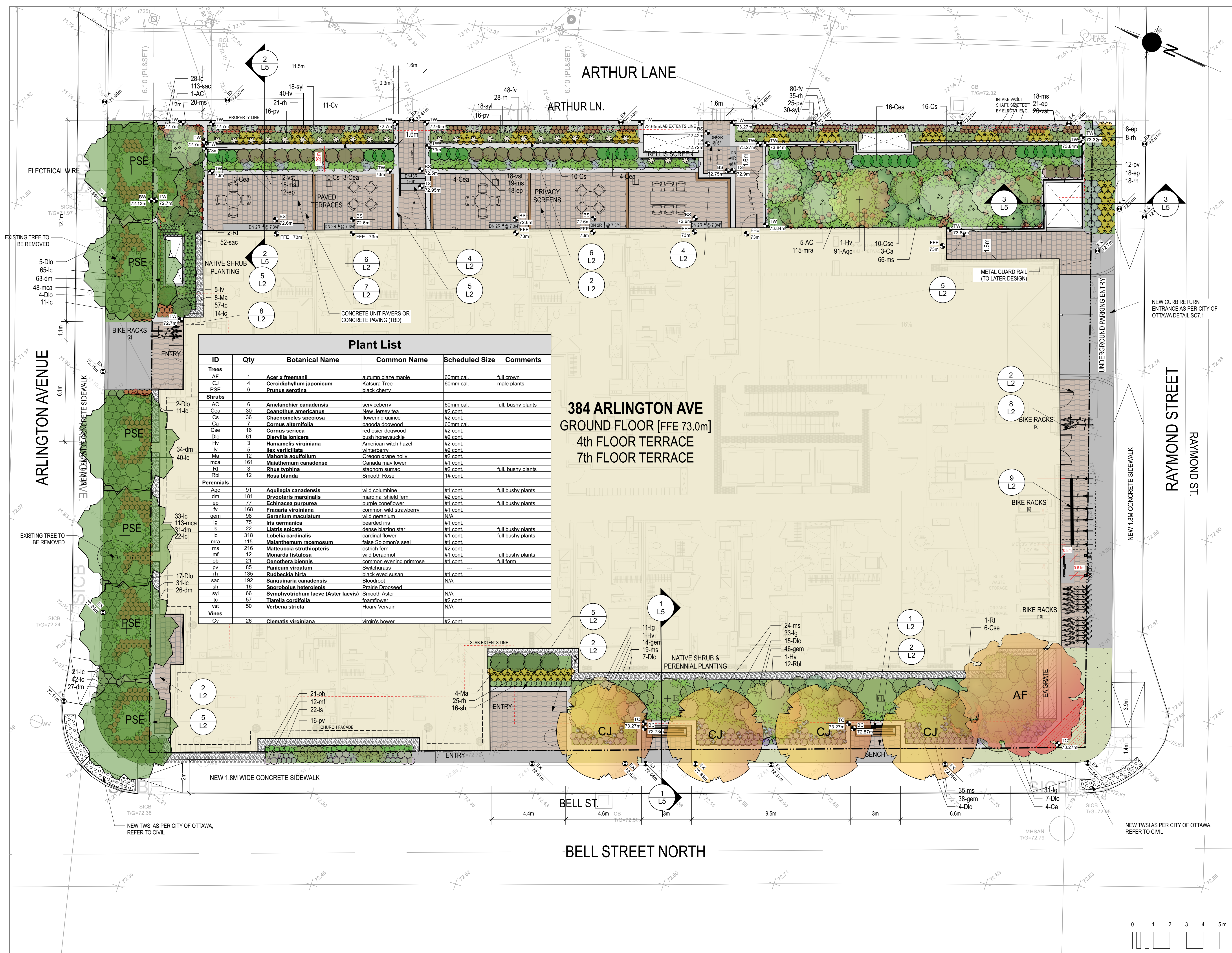

**Plant List**

ID	Qty	Botanical Name	Common Name	Scheduled Size	Comments
<b>Trees</b>					
AF	1	<i>Acer x freemanii</i>	autumn blaze maple	60mm cal.	full crown
CJ	4	<i>Cercidiphyllum japonicum</i>	Katsura Tree	60mm cal.	male plants
PSE	6	<i>Prunus serotina</i>	black cherry		
<b>Shrubs</b>					
AC	6	<i>Amelanchier canadensis</i>	serviceberry	60mm cal.	full, bushy plants
Cea	30	<i>Ceanothus americanus</i>	New Jersey tea	#2 cont.	
Ca	36	<i>Chaenomeles speciosa</i>	flowering quince	#2 cont.	
Ca	7	<i>Cornus alternifolia</i>	paocoda dogwood	60mm cal.	
Cse	16	<i>Cornus sericea</i>	red osier dogwood	#2 cont.	
Dlo	61	<i>Diervilla lonicera</i>	bush honeysuckle	#2 cont.	
Hv	3	<i>Hamelis virginiana</i>	American witch hazel	#2 cont.	
lv	5	<i>Ilex verticillata</i>	winterberry	#2 cont.	
Ma	12	<i>Mahonia aquifolium</i>	Oregon grape holly	#2 cont.	
mca	161	<i>Maianthemum canadense</i>	Canada mayflower	#1 cont.	
Rt	3	<i>Rhus typhina</i>	staghorn sumac	#2 cont.	full, bushy plants
Rbl	12	<i>Rosa blanda</i>	Smooth Rose	1# cont.	
<b>Perennials</b>					
Aqc	91	<i>Aquilegia canadensis</i>	wild columbine	#1 cont.	full bushy plants
dm	181	<i>Dryopteris marginalis</i>	maroon shield fern	#2 cont.	
ep	77	<i>Echinacea purpurea</i>	purple coneflower	#1 cont.	full bushy plants
fv	168	<i>Fragaria virginiana</i>	common wild strawberry	#1 cont.	
gem	98	<i>Geranium maculatum</i>	wild geranium	N/A	
lg	75	<i>Iris germanica</i>	bearded iris	#1 cont.	
ls	22	<i>Liatris spicata</i>	dense blazing star	#1 cont.	full bushy plants
lc	318	<i>Lobelia cardinalis</i>	cardinal flower	#1 cont.	full bushy plants
mra	115	<i>Maianthemum racemosum</i>	false Solomon's seal	#1 cont.	
ms	216	<i>Matteuccia struthiopteris</i>	ostrich fern	#2 cont.	
mf	12	<i>Monarda fistulosa</i>	wild bergamot	#1 cont.	full bushy plants
ob	21	<i>Oenothera biennis</i>	common evening primrose	#1 cont.	full form
pv	85	<i>Panicum virgatum</i>	Switchgrass	#1 cont.	
rh	135	<i>Rudbeckia hirta</i>	black eyed susan	#1 cont.	
sac	192	<i>Sanguinaria canadensis</i>	Bloodroot	N/A	
sh	16	<i>Sporobolus heterolepis</i>	Prairie Dropseed	#1 cont.	
svl	66	<i>Symphoricarpon laeve (Aster laevis)</i>	Smooth Aster	N/A	
tc	57	<i>Tiarrella cordifolia</i>	foamflower	#2 cont.	
vst	50	<i>Verbena stricta</i>	Hoary Vervain	N/A	
<b>Vines</b>					
Cv	26	<i>Clematis virginiana</i>	virgin's bower	#2 cont.	

**384 ARLINGTON AVE**  
GROUND FLOOR [FFE 73.0m]  
4th FLOOR TERRACE  
7th FLOOR TERRACE

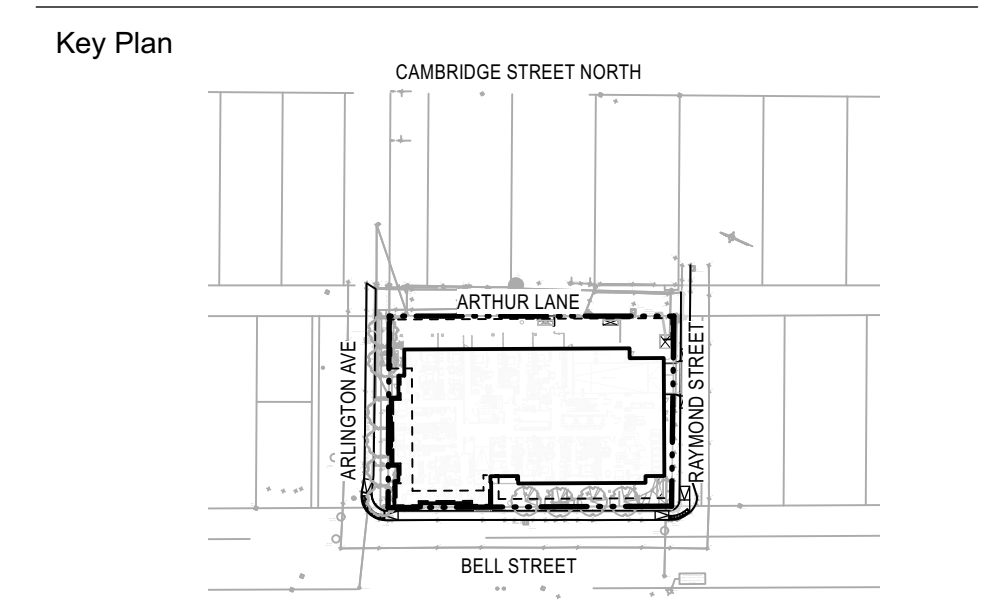

- LEGEND:**
- Property Line
  - Sod
  - Concrete Pavers (4th, 7th floors)
  - Conc. Unit Pavers or Conc. Paving
  - Bench
  - Stone Planter Curb
  - 450mm Drip Strip
  - Stone Steps
  - Metal Planters
- GRADING LEGEND:**
- Existing Survey Grade
  - Existing Grade
  - Proposed Grade
  - TW Top of Wall
  - BW Bottom of Wall
  - TC Top of Curb
  - BR Bottom of Ramp
  - TS Top of Step
  - BS Bottom of Step

- 10
  - 9
  - 8
  - 7
  - 6
  - 5
  - 4
  - 3
  - 2
- 4 SPC FORMAL SUBMISSION REV 1 2024-12-04  
3 ISSUED FOR SPC FORMAL SUBMISSION 2024-10-04  
2 ISSUED FOR SPA 2 2024-06-06  
1 ISSUED FOR SPA 2024-02-09

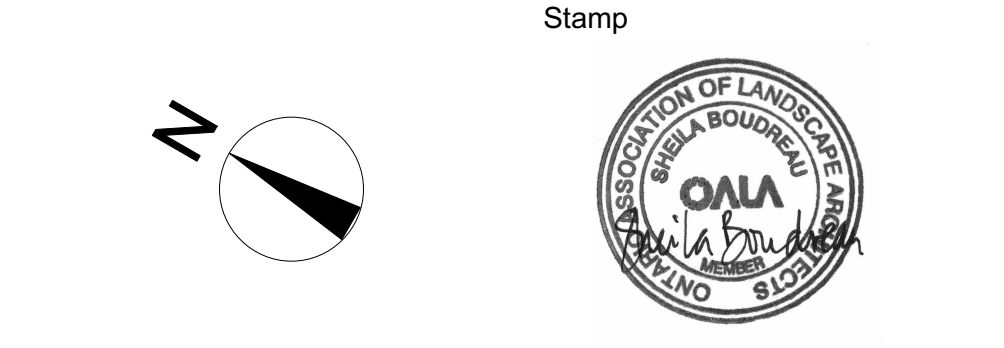

**SpruceLab Inc.**  
Address: 550 Bayview Ave, Suite 300  
Toronto, ON, M4W 3X8  
Telephone: (647) 899-5891  
www.spruceclab.ca

Note:  
All drawing information shall be checked and verified and any discrepancies reported in writing to the Landscape Architect before commencing any affected work. This drawing shall be used only for the project named on this drawing and for reference purposes only. This drawing shall not be scaled. This drawing is not for construction unless signed by the Landscape Architect. This drawing and all aspects of its content are the copyright property of SpruceLab. Reproduction in whole or in part, by any means whatsoever, without the express written permission of SpruceLab, is prohibited.

Legal Description: Lts 14 & 15, Pt 33, (S of Stone Boundary) E Bell St N, Pt Lts 13 & 16, Pt 33, (S of Stone Boundary) E Bell St N, as in C/O1653, C/O1496, C/O472519 & C/O15256, Ottawa/Nepean

Client  
**Windmill Developments**  
Toronto, ON

Project  
**384 ARLINGTON AVE**  
OTTAWA, ON  
Property Identification Number: 04105-0128

Drawing Title  
**Landscape Plan - Gound Floor**

Scale: 1:100  
Designed By: SB  
Drawn By: KG/NS  
Approved By: SB  
Date: 10/13/21

Project # 0.001  
Drawing # **L1.1**

**NOT FOR CONSTRUCTION**

File: D07-12-24-0127, Plan: 19189

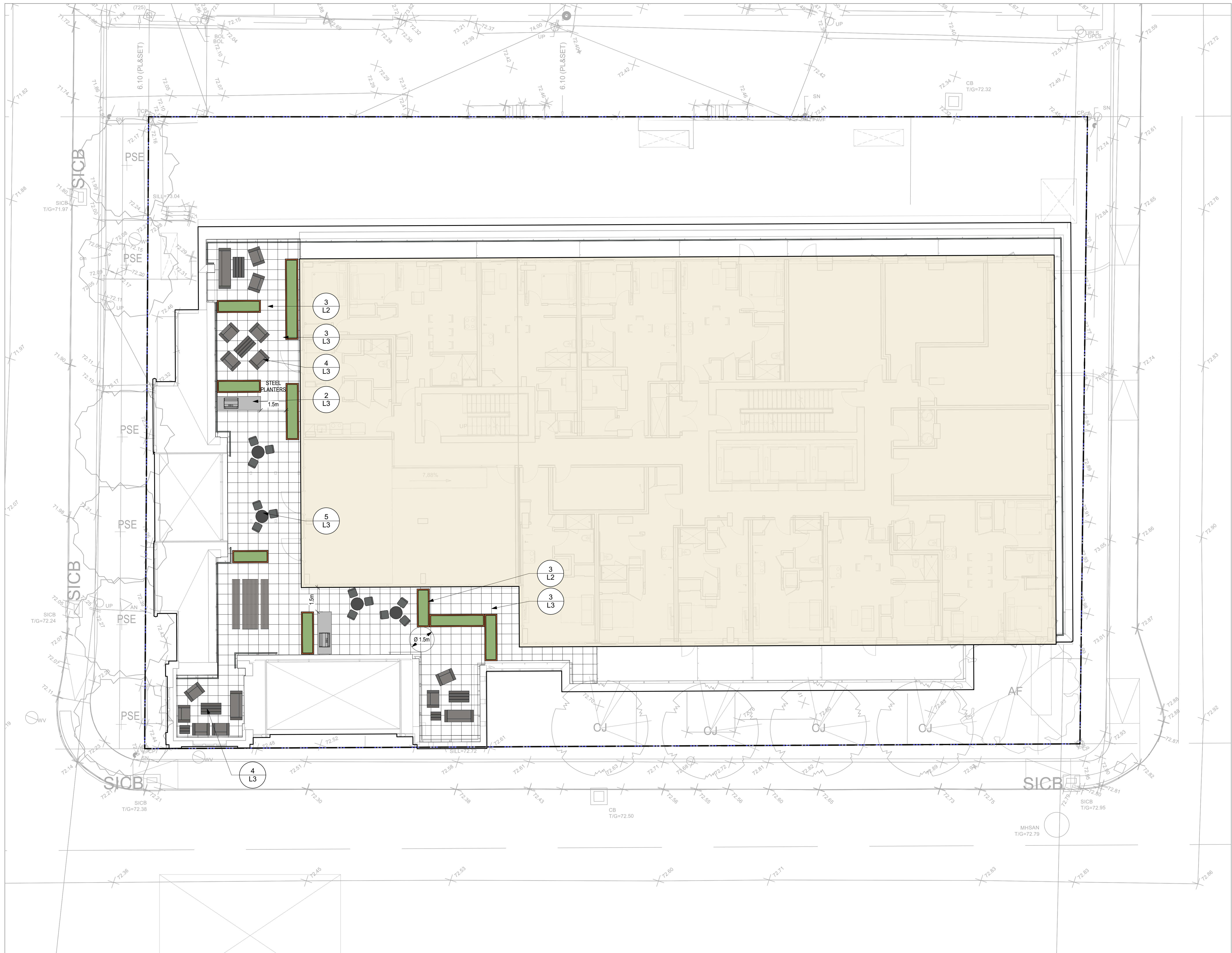

Key Plan

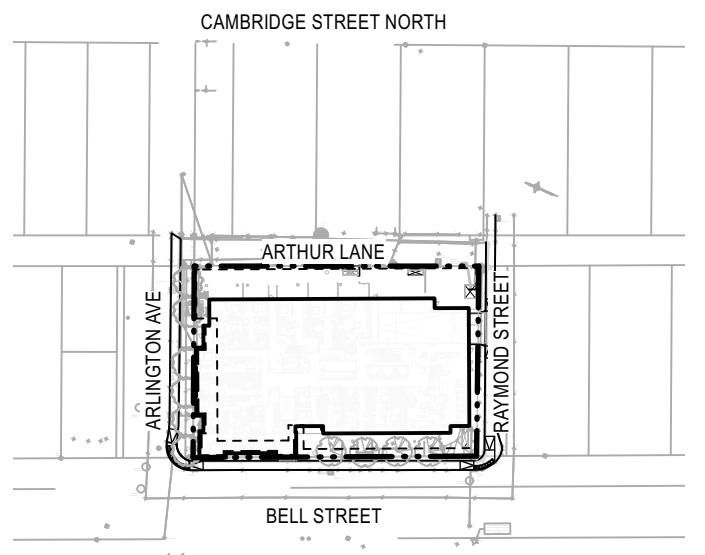

Legend

10		
9		
8		
7		
6		
5		
4	SPC FORMAL SUBMISSION REV 1	2024-12-04
3	ISSUED FOR SPC FORMAL SUBMISSION	2024-10-04
2	ISSUED FOR SPA 2	2024-06-06
1	ISSUED FOR SPA	2024-02-09

Stamp

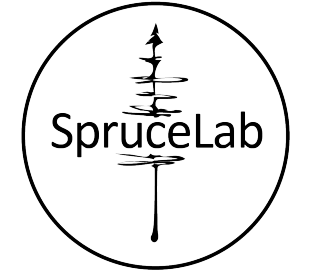
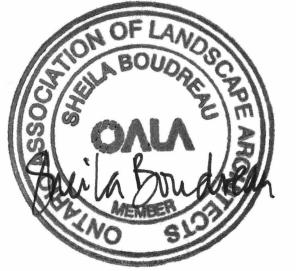
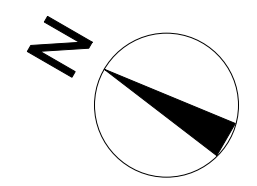

**SpruceLab Inc.**  
 Address: 550 Bayview Ave, Suite 300  
 Toronto, ON, M4W 3X8  
 Telephone: (647) 899-5891  
 www.sprucelab.ca

**Note:**  
 All drawing information shall be checked and verified and any discrepancies reported in writing to the Landscape Architect before commencing any affected work. This drawing shall be used only for the project named on this drawing and for reference purposes only. This drawing shall not be scaled. This drawing is not for construction unless signed by the Landscape Architect. This drawing and all aspects of its content are the copyright property of SpruceLab. Reproduction in whole or in part, by any means whatsoever, without the express written permission of SpruceLab, is prohibited.

**Legal Description:** Lts 14 & 15, Pt 33, (S Of Stone Boundary) E Bell St N, Pt Lts 13 & 16, Pt 33, (S Of Stone Boundary) E Bell St N, as in CrO1653, Cr101496, C472519 & Cr513256, Ottawa/Nepean

Client

**Windmill Developments**  
 Toronto, ON

Project  
**384 ARLINGTON AVE**  
 OTTAWA, ON

Property Identification Number: 04105-0128

Drawing Title  
**Landscape Plan - 4th Floor**

Scale:	Project #
Designed By: SB	0.001
Drawn By: KG/NS	Drawing #
Approved By: SB	<b>L1.2</b>
Date: 10/13/21	

**NOT FOR CONSTRUCTION**

File: D07-12-24-017, Plan: 19189

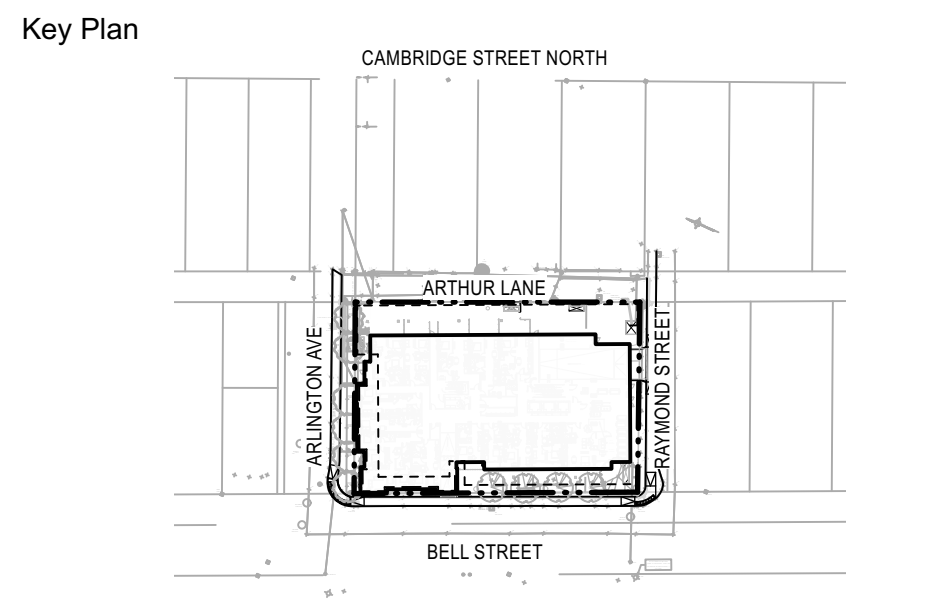
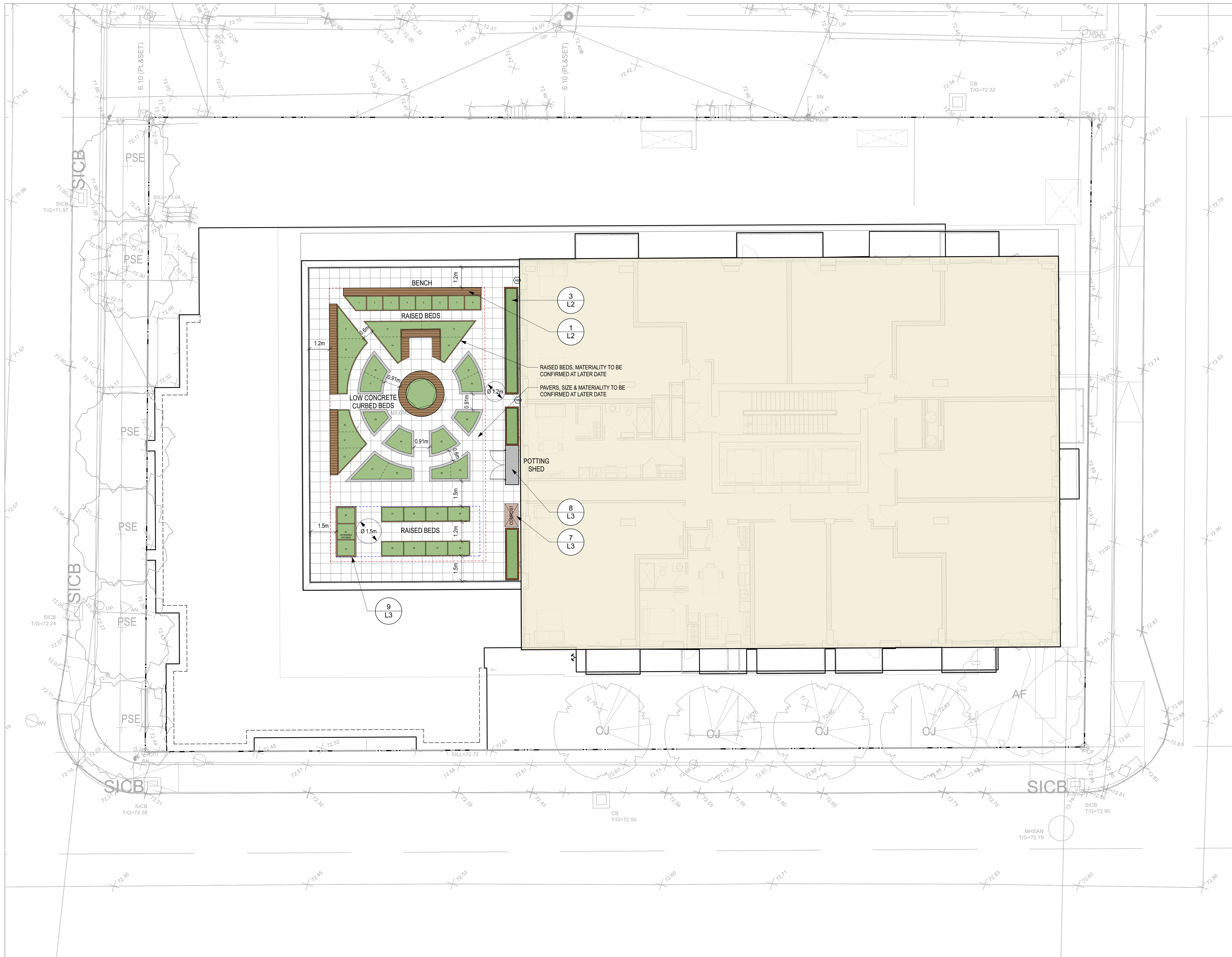

Legend

10		
9		
8		
7		
6		
5		
4	SPC FORMAL SUBMISSION REV 1	2024-12-04
3	ISSUED FOR SPC FORMAL SUBMISSION	2024-10-04
2	ISSUED FOR SPA 2	2024-06-06
1	ISSUED FOR SPA	2024-02-09

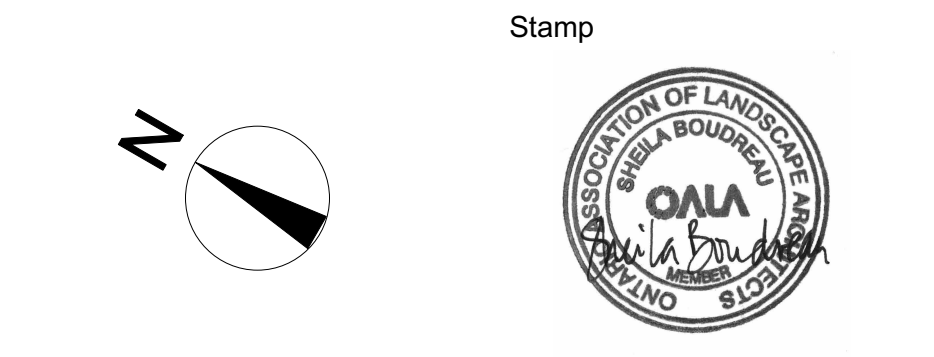

**SpruceLab Inc.**  
 Address: 550 Bayview Ave, Suite 300  
 Toronto, ON, M4W 3X8  
 Telephone: (647) 899-5891  
 www.sprucelab.ca

Note:  
 All drawing information shall be checked and verified and any discrepancies reported in writing to the Landscape Architect before commencing any affected work. This drawing shall be used only for the project named on this drawing and for reference purposes only. This drawing shall not be scaled. This drawing is not for construction unless signed by the Landscape Architect. This drawing and all aspects of its content are the copyright property of SpruceLab. Reproduction in whole or in part, by any means whatsoever, without the express written permission of SpruceLab, is prohibited.

Legal Description: Lts 14 & 15, Pl 33, (S Of Stone Boundary) E Bell St N, Pl Lts 13 & 16, Pl 33, (S Of Stone Boundary) E Bell St N, as in C/O1653, C/O1496, C/O42519 & C/O513256, Ottawa/Nepean

Client  
**Windmill Developments**  
 Toronto, ON

Project  
**384 ARLINGTON AVE**  
**OTTAWA, ON**

Property Identification Number: 04105-0128  
 Drawing Title  
**Landscape Plan - 7th Floor**

Scale:	Project #
Designed By: SB	0.001
Drawn By: KG/NS	Drawing #
Approved By: SB	<b>L1.3</b>
Date: 10/13/21	

**NOT FOR CONSTRUCTION**

File: D07-12-24-017, Plan: 19189



ROUGHREADY BENCH BY STREETLIFE WITH BACK & ARM RESTS  
CUT SHEET PENDING



**INDUSTRIA 300 SERIES**

DESCRIPTION: Paver TEXTURE: HD<sup>3</sup> Polished

PALLET OVERVIEW - 300x100

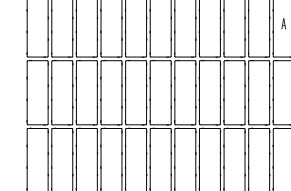

PALLET OVERVIEW - 300x150

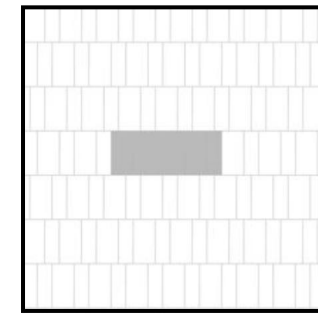
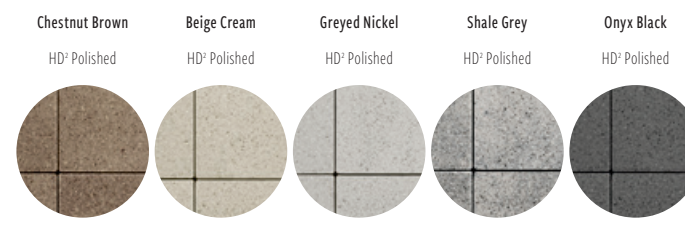

Specifications per pallet		Imperial	Metric
300x150	Cubing	71.20 Ft <sup>2</sup>	6.62 m <sup>2</sup>
	Approx. Weight	3 288 lbs	1 491 kg
	Number of rows	7	
	Coverage per row	10.17 Ft <sup>2</sup>	0.95 m <sup>2</sup>
	Linear coverage per row	Depth 20.67 lin. ft	6.30 lin. m
		Length 10.33 lin. ft	3.15 lin. m



**NOTES**  
See page 62 to 64 for more technical information.  
See page 30 for more information about applications.  
300 Series HD<sup>3</sup> Polished and HD<sup>3</sup> Granite are made-to-order, minimum order of 500 sq. ft. Deposit required. HD<sup>3</sup> Smooth is in stock with shorter lead times.

Unit dimensions	in	mm	Units/pallet
Height	3 3/4	98	147 units
Width	11 1/4	300	
Length	5 3/4	150	

2 DETAIL: PAVERS  
Scale: N.T.S.

1 DETAIL: BENCH  
Scale: N.T.S.

**Product Sheet Shrubtubs Square**

Steel tree planter including 7cm high supports rails at the bottom and a 6 cm wide lip at the top

Product Code **STUB-PL-90-180-90-CT / STUB-PL-90-180-90-PC**

Dimensions ca. 90x180x90 cm | 35x71x35" (l=w×h), vol. 1,35 m<sup>3</sup> | 48 ft<sup>3</sup>

Weight Empty ca. 220 kg | 485 lbs  
Filled with soil approx. 2515kg | 5545 lbs (based on 1700 kg / m<sup>3</sup>)

Material Planter (-CT) version: Corten Steel (weathering steel) 4mm thick, delivered unweathered  
Planter (-PC) version: Corten Steel (weathering steel), finished with a double powder coating in RAL colour

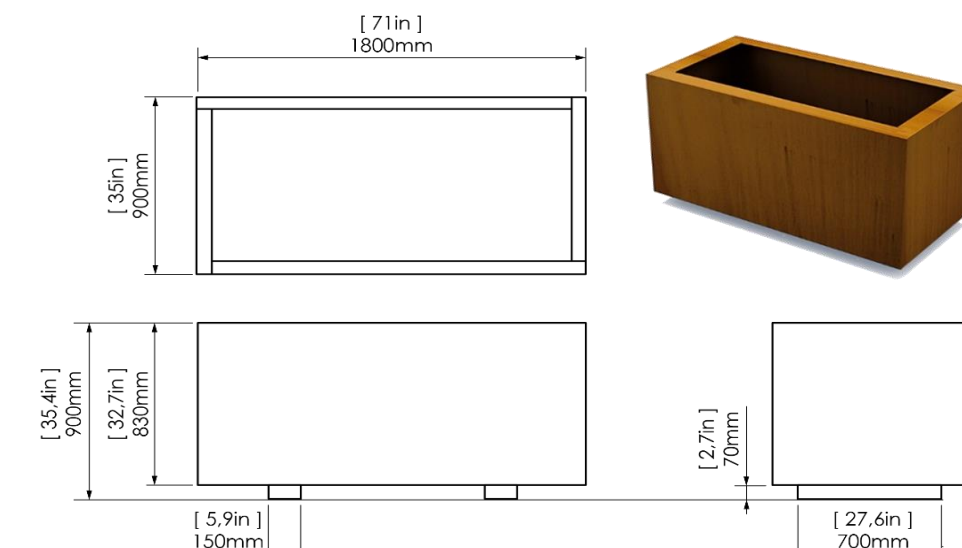

\*Metric units are leading  
Design: Streetlife  
Protected by int. Modeldepots & Patents



NOTE: TO BE CUSTOM DESIGNED TO THE FOLLOWING DIMENSIONS (HEIGHT)

3 DETAIL: CORTEN STEEL RAISED PLANTERS  
Scale: N.T.S.

**ERAMOSA-FLAGSTONE™ COLLECTION**  
Product Specifications

**ROCKFACE STEPS**

48" x 16" x 6"  
(1207mm x 406mm x 152mm)

72" x 16" x 6"  
(1810mm x 432mm x 150mm)

**APPLICATIONS**

steps, retaining walls, seat walls, raised landings

**FEATURES**

- flamed top finish with low relief texture
- flamed ends for tighter joints
- rockface front with natural undercuts

**AVAILABLE COLOURS**

sand buff, charcoal grey, terra brown

4 MATERIAL: ROCK FACE STEPS  
Scale: N.T.S.

**ORILLIA GUILLOTINE WALL-STONE™ COLLECTION**  
Product Specifications

**WALL STONE**

18"L x 12"W x 4"H  
(444mm x 300mm x 102mm)

18"L x 12"W x 4"H - Wall Ends  
(444mm x 300mm x 102mm)

**APPLICATIONS**

retaining walls, planters, steps, pool copings, water features, garden beds, raised landings

**FEATURES**

- sawn bed and ends
- authentic sawn texture
- natural guillotine finish on two sides
- tight joints for seamless appearance
- wall ends - guillotine finish on three sides

**AVAILABLE COLOURS**

sand buff, charcoal grey, terra brown

5 MATERIAL: RETAINING WALL STONE  
Scale: N.T.S.

POTENTIAL FOR INDIGENOUS CUSTOM ART DESIGN

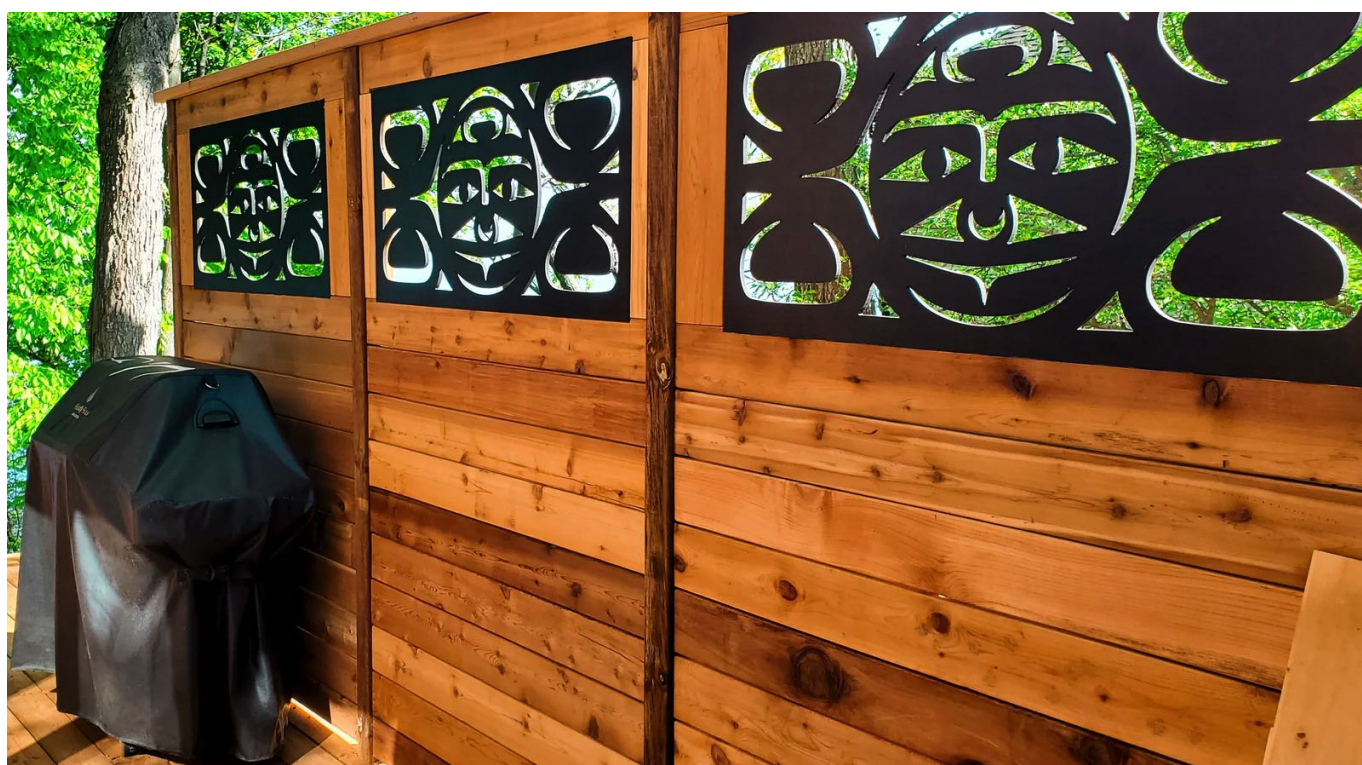

7 DETAIL: 6" WOOD PRIVACY SCREEN W/ POTENTIAL ART  
Scale: N.T.S.



Multiple Series



STANDARD SPECIFICATIONS

Boa model, as manufactured by Dobra Design, Vancouver BC. (604-733-9486) info@dobradesign.com  
Material to be Hollow Structural Steel Tubing, 1.900 x 0.100" (48mm x 2.24mm) ASTM A500C  
Preparation to be by Mechanical and Chemical cleaning and Iron Phosphate treatment  
Finish to be electrostatic polyester powdercoating in triple-thick MaxiCoat™ with oven curing  
Installation to be by flush, drop-in anchors and button-head capscrews 1/2" UNC (12.7mm), 2 per rack  
All fasteners to be concealed inside rack tubes for safety and vandal resistance and access holes capped  
Stainless Steel Boa series to be 1 1/2" SCH 10 x 0.109 304 stainless steel pipe with #4 Architectural finish

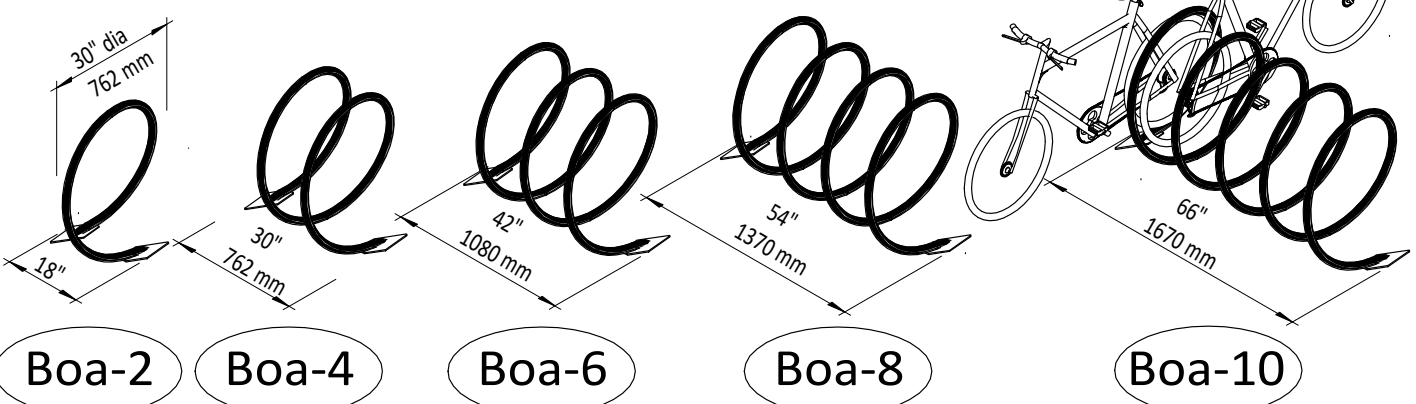

8 DETAIL: Bike Rack  
Scale: N.T.S.

6 DETAIL: GREENSCREEN  
Scale: N.T.S.

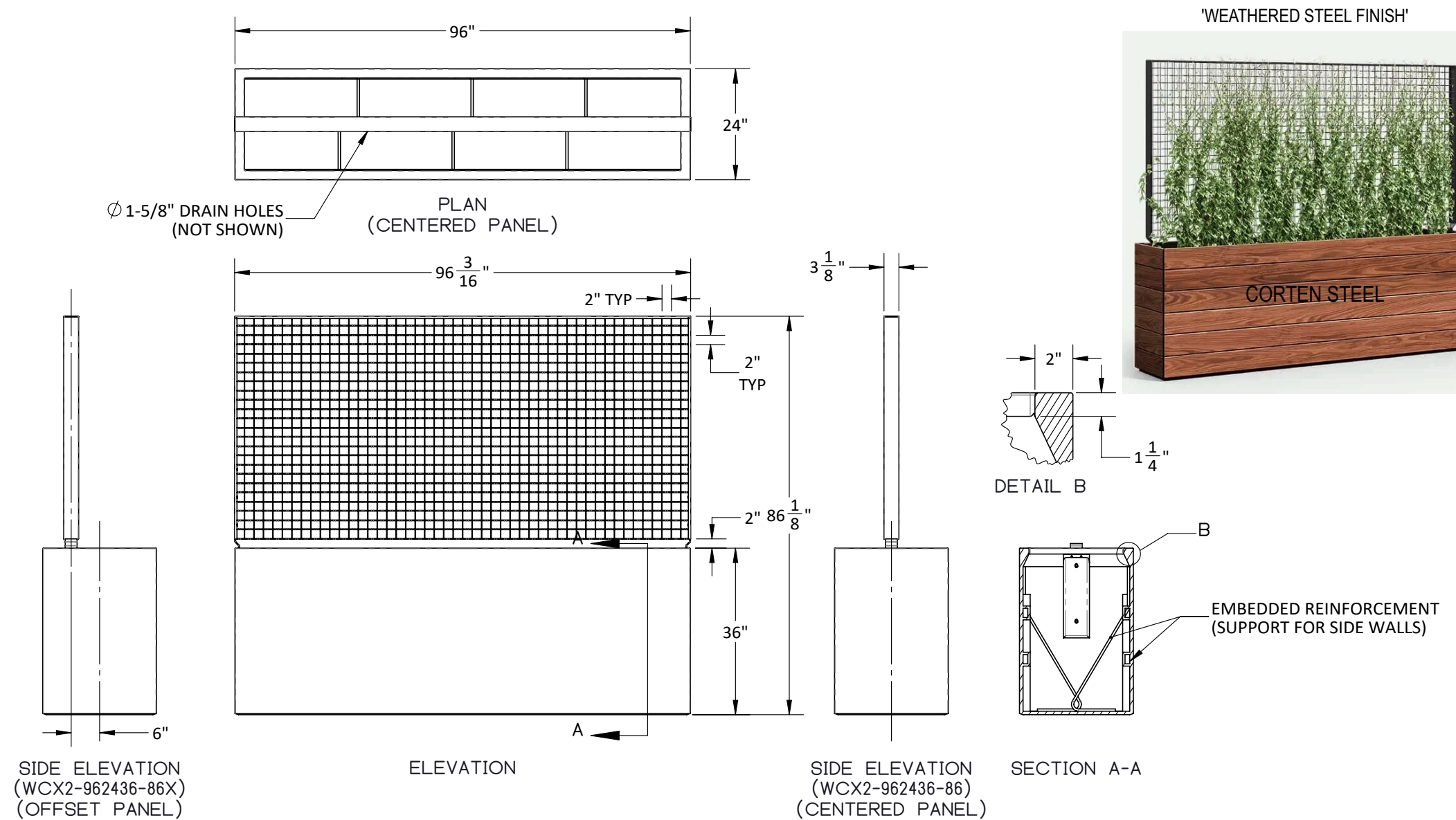

9 DETAIL: Custom Bike Rack  
Scale: N.T.S.

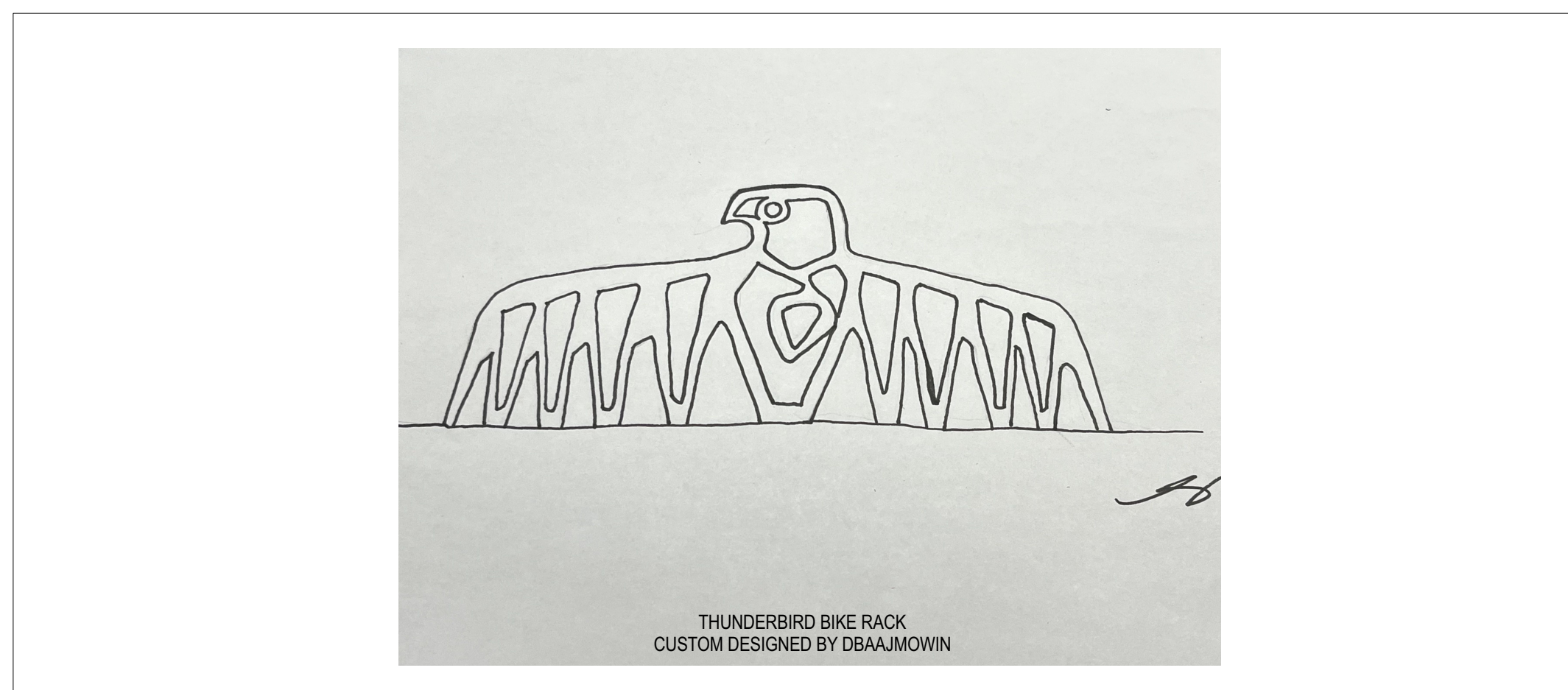

Key Plan

Legend

10		
9		
8		
7		
6		
5		
4	SPC FORMAL SUBMISSION REV 1	2024-12-04
3	ISSUE FOR SPC FORMAL SUBMISSION	2024-10-04
2	ISSUED FOR SPA 2	2024-06-06
1	ISSUED FOR SPA	2024-02-09

Stamp

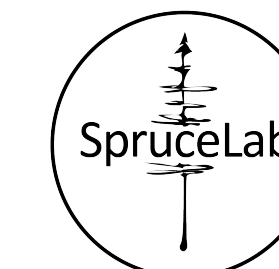

**SpruceLab Inc.**

Address: 550 Bayview Ave, Suite 300  
Toronto, ON, M4W 3X8

Telephone: (647) 899-5891

www.spruceclub.ca

**Note:**

All drawing information shall be checked and verified and any discrepancies reported in writing to the Landscape Architect before commencing any affected work. This drawing shall be used only for the project named on this drawing and for reference purposes only. This drawing shall not be scaled. This drawing is not for construction unless signed by the Landscape Architect. This drawing and all aspects of its content are the copyright property of SpruceLab. Reproduction in whole or in part, by any means whatsoever, without the express written permission of SpruceLab, is prohibited.

Legal Description: Lts 14 & 15, Pl 33, (S Of Stone Boundary) E Bell St N; Pl Lts 13 & 16, Pl 33, (S Of Stone Boundary) E Bell St N; as in C31853, C101496, C472519 & C513256; Ottawa/Nepesee

Client

**Windmill Developments**  
Toronto, ON

Project

**384 ARLINGTON AVE**  
OTTAWA, ON

Property Identification Number: 04105-0128

Drawing Title

**Landscape Details - Ground Floor**

Scale: \_\_\_\_\_ Project # \_\_\_\_\_  
Designed By: SB \_\_\_\_\_ 0.001

Drawn By: KG/NS \_\_\_\_\_ Drawing # \_\_\_\_\_

Approved By: SB \_\_\_\_\_

Date: 10/13/21

**L2**

Plan#: 19189

**NOT FOR CONSTRUCTION**



HARVEST TABLE BY STREETLIFE  
CUT SHEET PENDING

1 DETAIL: Harvest Table  
Scale: N.T.S.

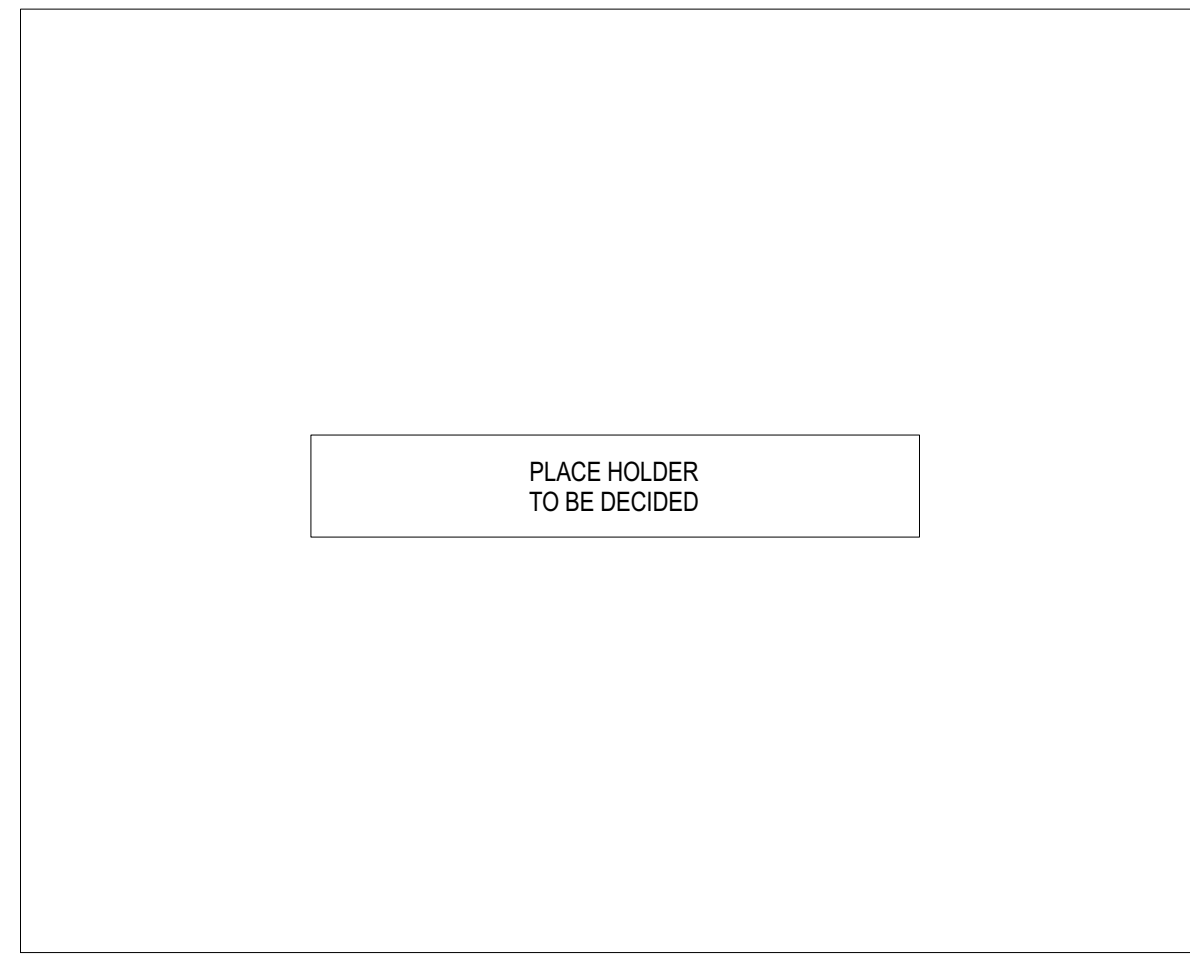

2 DETAIL: Outdoor Kitchen - BBQ & Counter  
Scale: N.T.S.

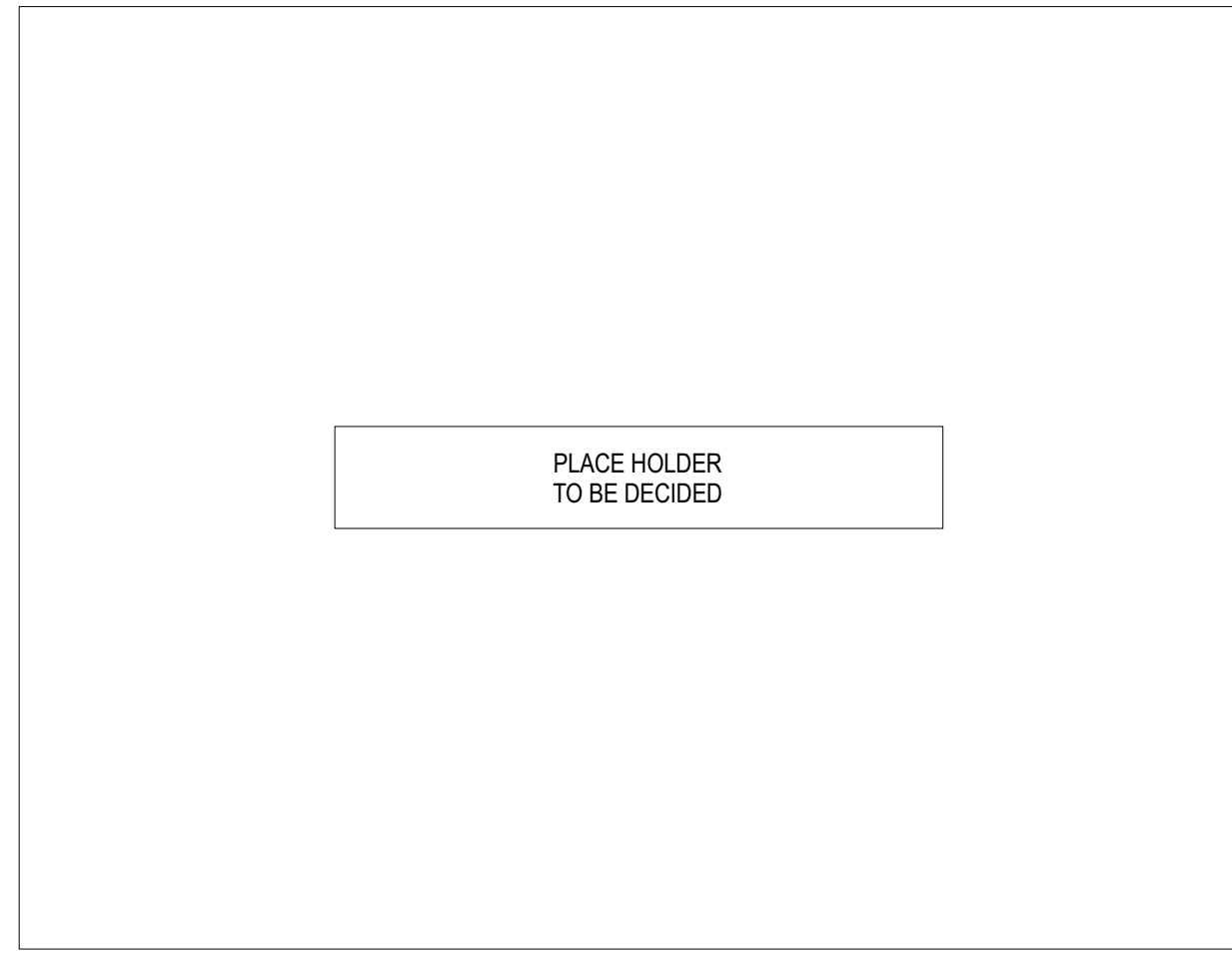

3 DETAIL: Pavers  
Scale: N.T.S.



LARNACA OUTDOOR SLATE GREY METAL x ALL-WEATHER WEAVE LINE

4 DETAIL: Lounge Furniture  
Scale: N.T.S.



RIVERVIEW OUTDOOR BISTRO SET - WEST ELM CANADA

5 DETAIL: Bistro Set  
Scale: N.T.S.

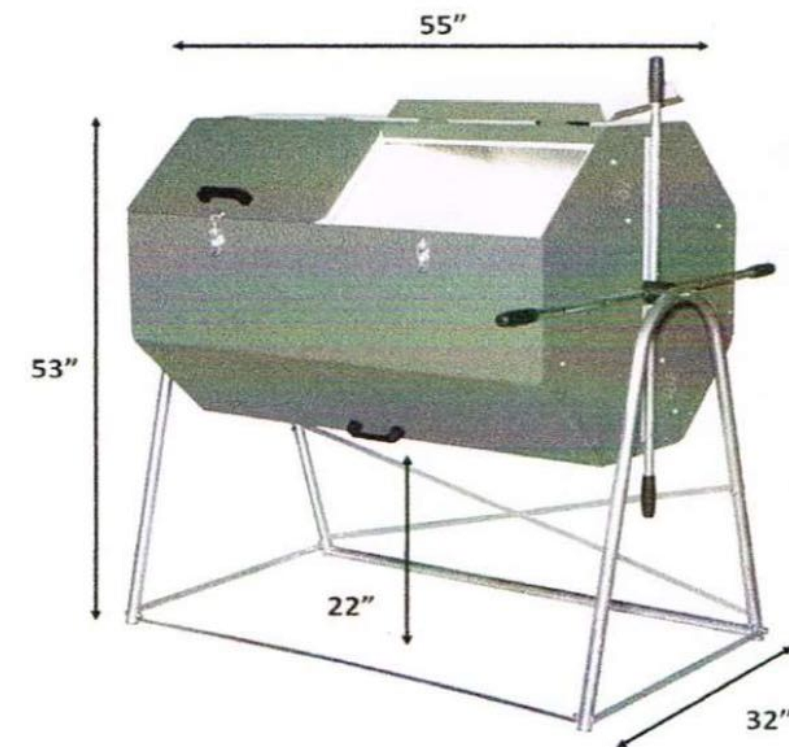

**ALL JORA COMPOSTERS**

**JK 400**  
UPC 13964468601

14.2 Cubic Feet  
106-Gallon Capacity

167 pounds  
Each JK400 Ships in **3 Boxes**

- Galvanized Steel
- Powder Coated I Green
- Low and High Density Polyethylene Insulation

7 DETAIL: Composter  
Scale: N.T.S.



8 DETAIL: Garden Shed  
Scale: N.T.S.

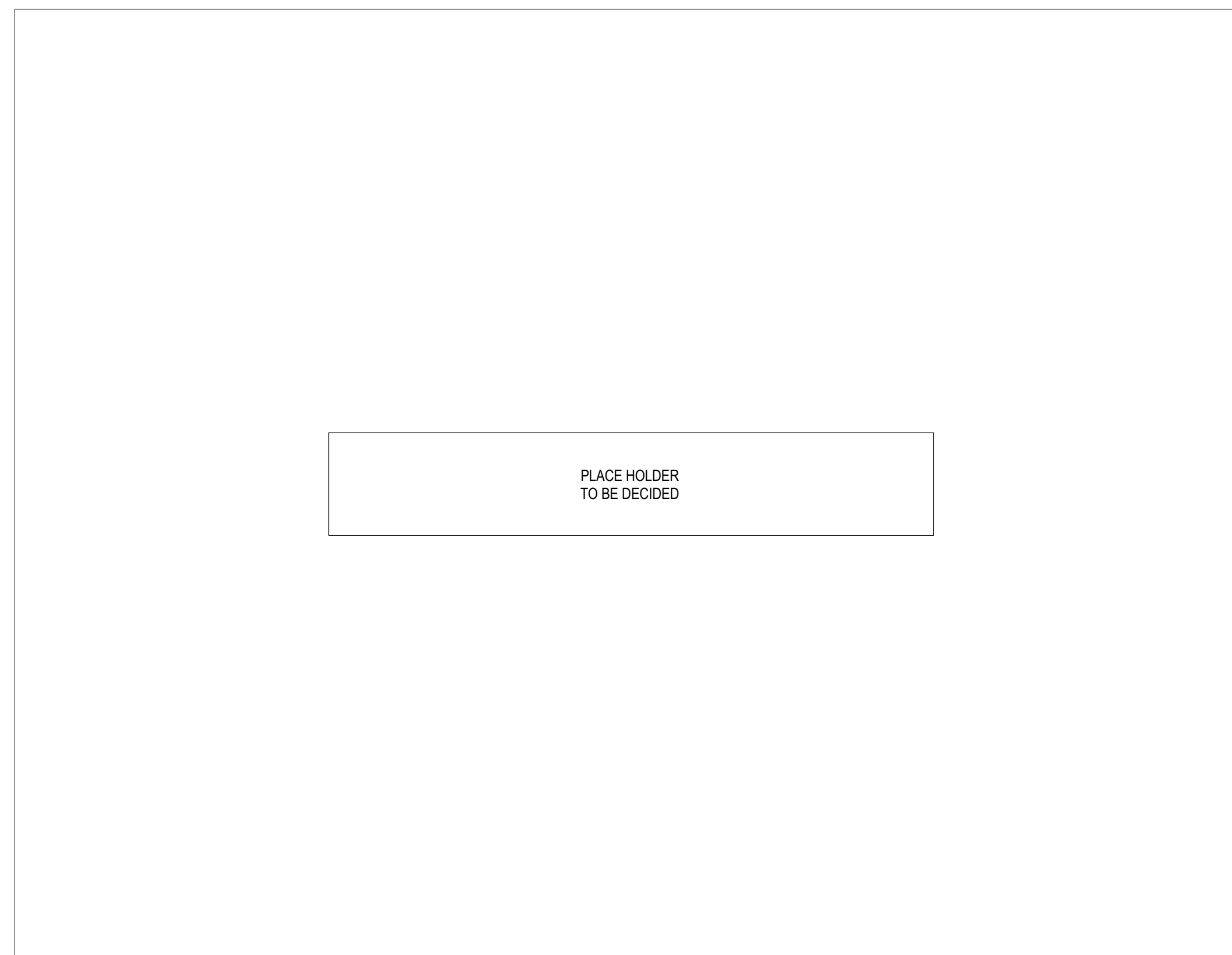

9 DETAIL: Wheelchair Accessible Raised Beds  
Scale: N.T.S.

Key Plan

Legend

10		
9		
8		
7		
5		
4	SPC FORMAL SUBMISSION REV 1	2024-12-04
3	ISSUE FOR SPC FORMAL SUBMISSION	2024-10-04
2	ISSUED FOR SPA 2	2024-06-06
1	ISSUED FOR SPA	2024-02-09

Stamp

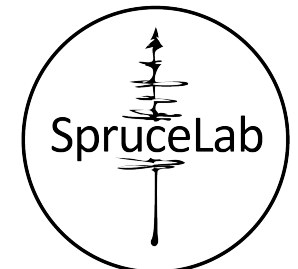
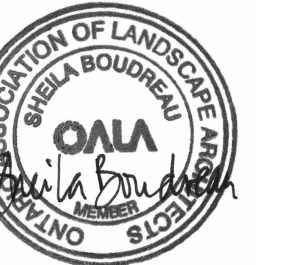

**SpruceLab Inc.**

Address: 550 Bayview Ave, Suite 300  
Toronto, ON, M4W 3X8  
Telephone: (647) 899-5891  
www.sprucelab.ca

**Note:**  
All drawing information shall be checked and verified and any discrepancies reported in writing to the Landscape Architect before commencing any affected work. This drawing shall be used only for the project named on this drawing and for reference purposes only. This drawing shall not be scaled. This drawing is not for construction unless signed by the Landscape Architect. This drawing and all aspects of its content are the copyright property of SpruceLab. Reproduction in whole or in part, by any means whatsoever, without the express written permission of SpruceLab, is prohibited.

Legal Description: Lts 14 & 15, Pl 33, (S Of Stone Boundary) E Bell St N; Pl Lts 13 & 16, Pl 33, (S Of Stone Boundary) E Bell St N; as in Cr31653, Cr101496, Cr472519 & Cr513256; Ottawa/Nepean

Client

**Windmill Developments**  
Toronto, ON

Project

**384 ARLINGTON AVE**  
OTTAWA, ON

Property Identification Number: 04105-0128

Drawing Title

**Landscape Details - Terraces**

Scale: \_\_\_\_\_ Project # \_\_\_\_\_  
Designed By: SB 0.001  
Drawn By: KG/NS Drawing # \_\_\_\_\_  
Approved By: SB  
Date: 10/13/21

**L3**  
Plan: 19169

**NOT FOR CONSTRUCTION**

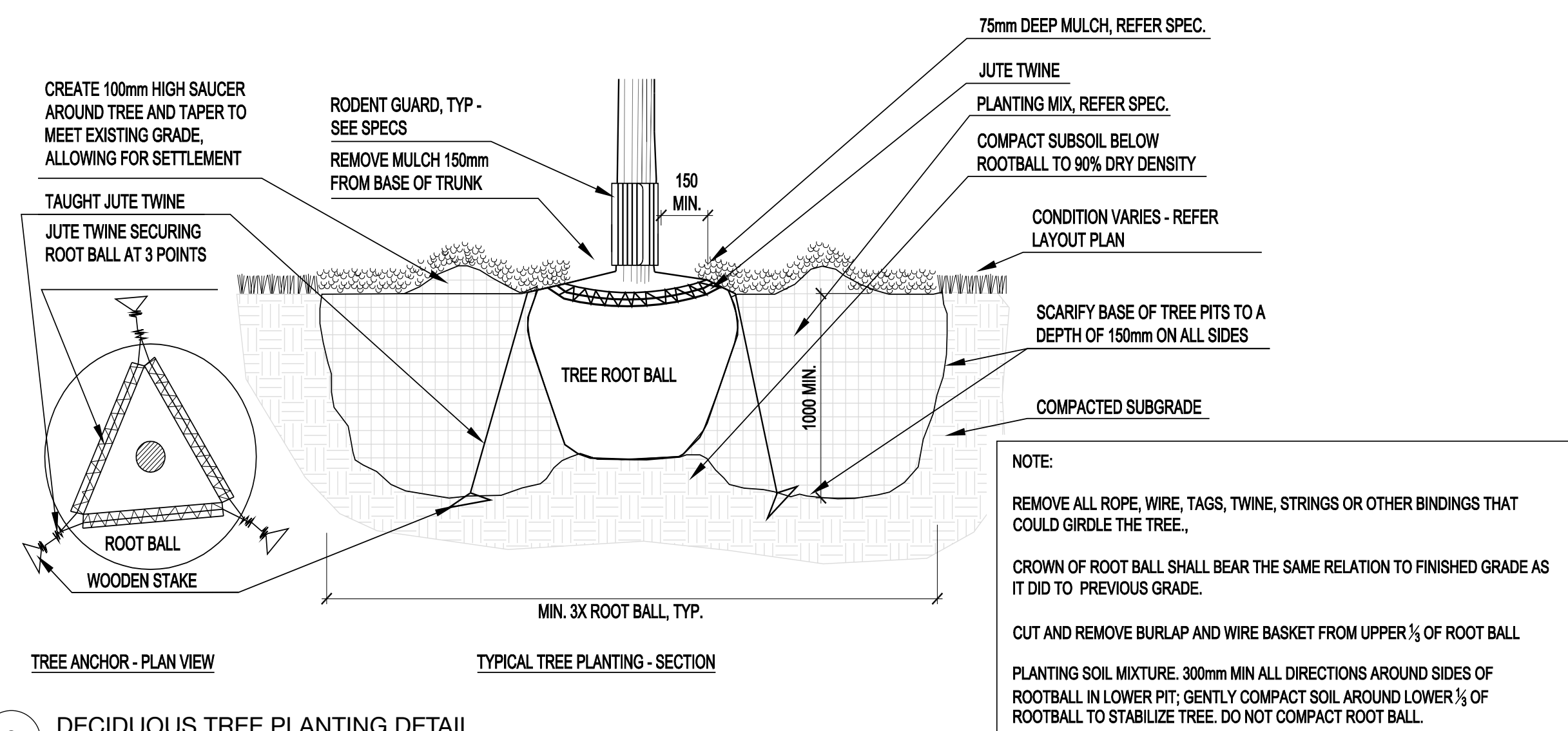

8 DECIDUOUS TREE PLANTING DETAIL  
 Scale: N.T.S.

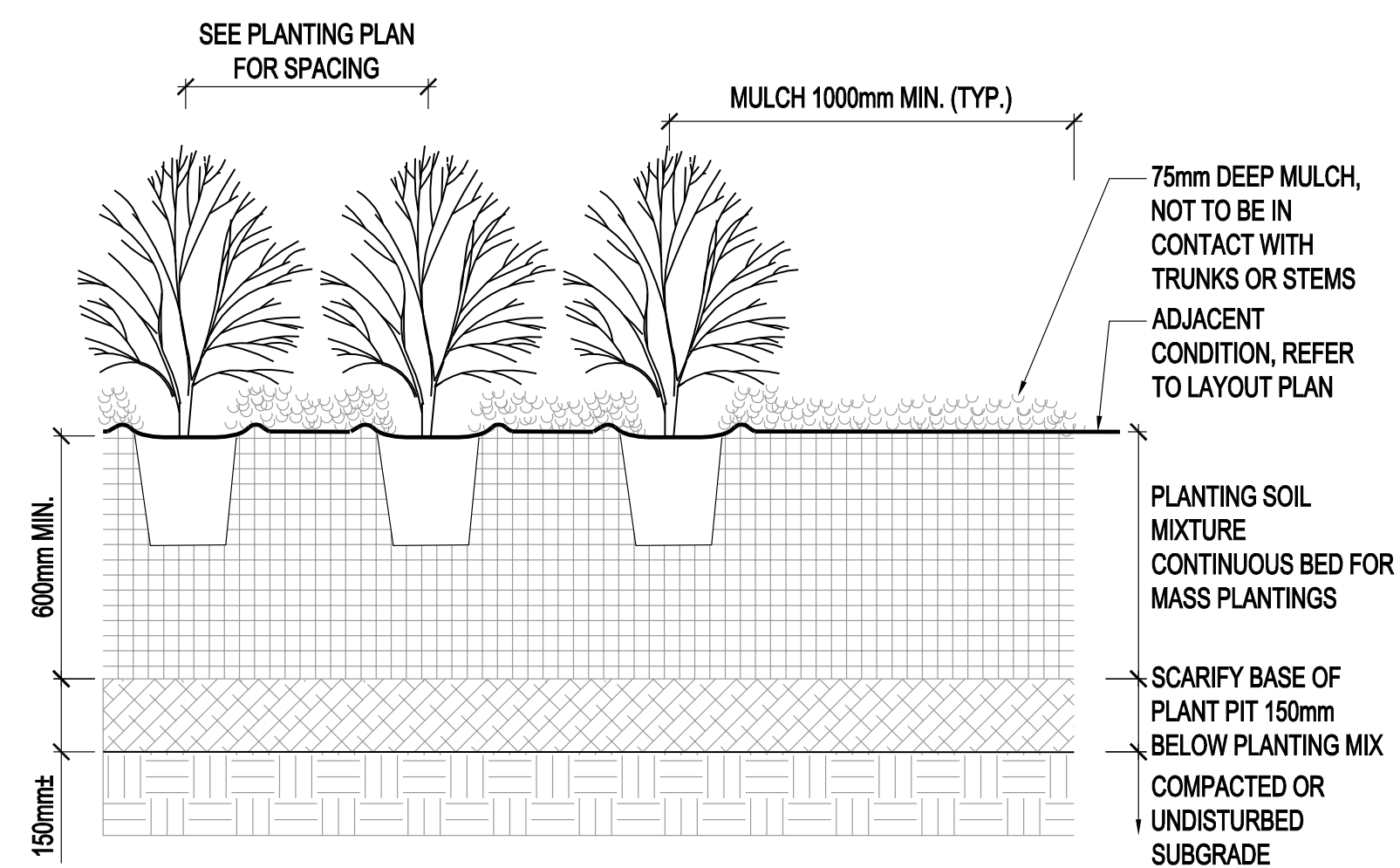

9 SHRUB PLANTING DETAIL  
 Scale: N.T.S.

Legend

10		
9		
8		
7		
6		
5		
4	SPC FORMAL SUBMISSION REV 1	2024-12-04
3	ISSUE FOR SPC FORMAL SUBMISSION	2024-10-04
2	ISSUED FOR SPA 2	2024-06-06
1	ISSUED FOR SPA	2024-02-09

Stamp

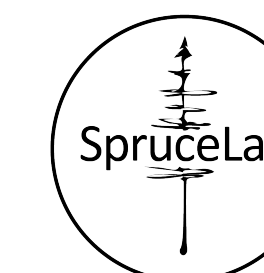

**SpruceLab Inc.**  
 Address: 550 Bayview Ave, Suite 300  
 Toronto, ON, M4W 3X8  
 Telephone: (647) 899-5891  
 www.sprucelab.ca

Note:  
 All drawing information shall be checked and verified and any discrepancies reported in writing to the Landscape Architect before commencing any affected work. This drawing shall be used only for the project named on this drawing and for reference purposes only. This drawing shall not be scaled. This drawing is not for construction unless signed by the Landscape Architect. This drawing and all aspects of its content are the copyright property of SpruceLab. Reproduction in whole or in part, by any means whatsoever, without the express written permission of SpruceLab, is prohibited.

Legal Description: Lts 14 & 15, Pl 33, (S Of Stone Boundary) E Bell St N; Pl Lts 13 & 16, Pl 33, (S Of Stone Boundary) E Bell St N; as in Cr31653, Cr101496, Cr472519 & Cr513258; Ottawa/Nepean

Client

**Windmill Developments**  
 Toronto, ON

Project

**384 ARLINGTON AVE**  
 OTTAWA, ON

Property Identification Number: 04105-0128

Drawing Title

**Planting Details**

Scale:	Project #
Designed By: SB	0.001
Drawn By: KG/NS	Drawing #
Approved By: SB	<b>L4</b>
Date: 10/13/21	

**NOT FOR CONSTRUCTION**