

APPROVED
By Kersten Nitsche at 11:52 am, Nov 27, 2024

Kersten Nitsche

**KERSTEN NITSCHKE, MCIP RPP
MANAGER (A), DEVELOPMENT REVIEW WEST
PLANNING, DEVELOPMENT AND BUILDING SERVICES
DEPARTMENT, CITY OF OTTAWA**

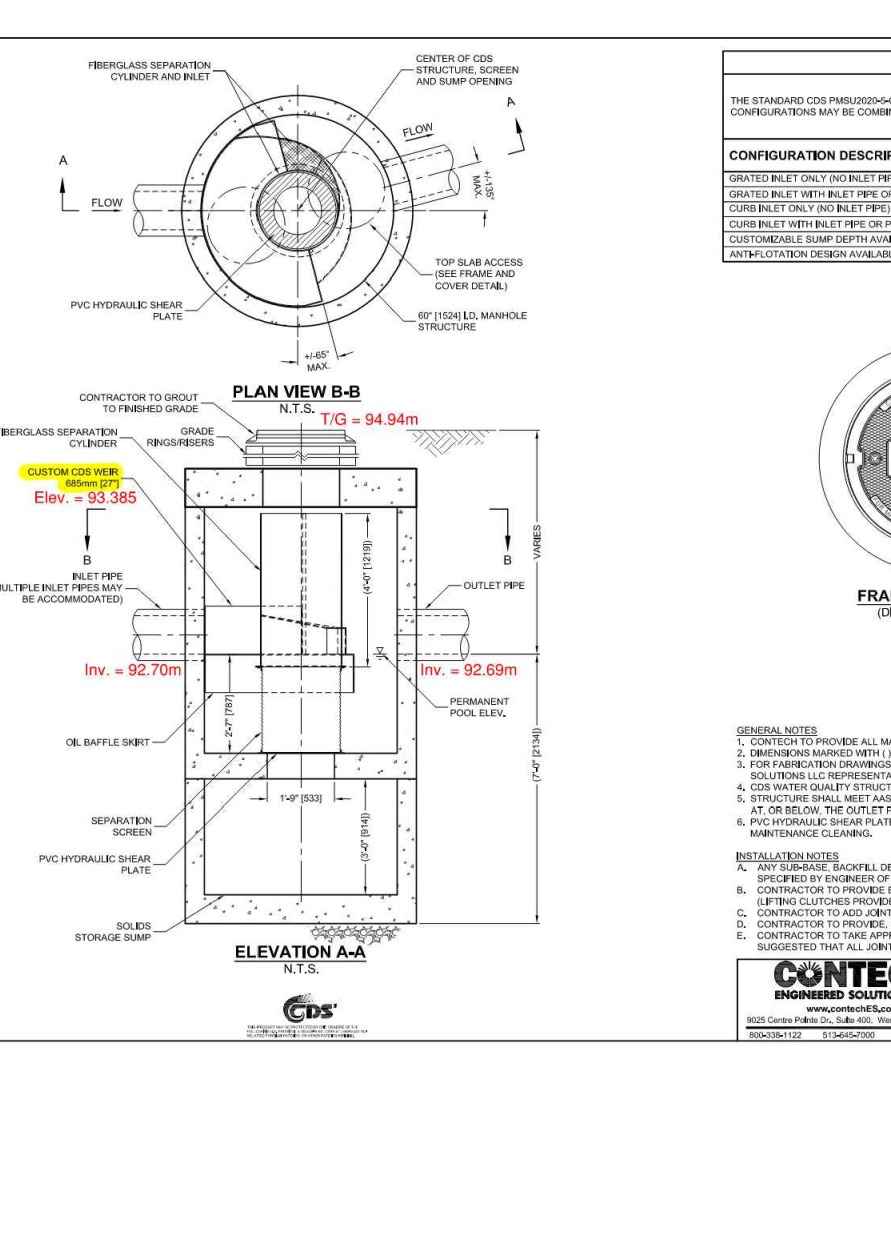
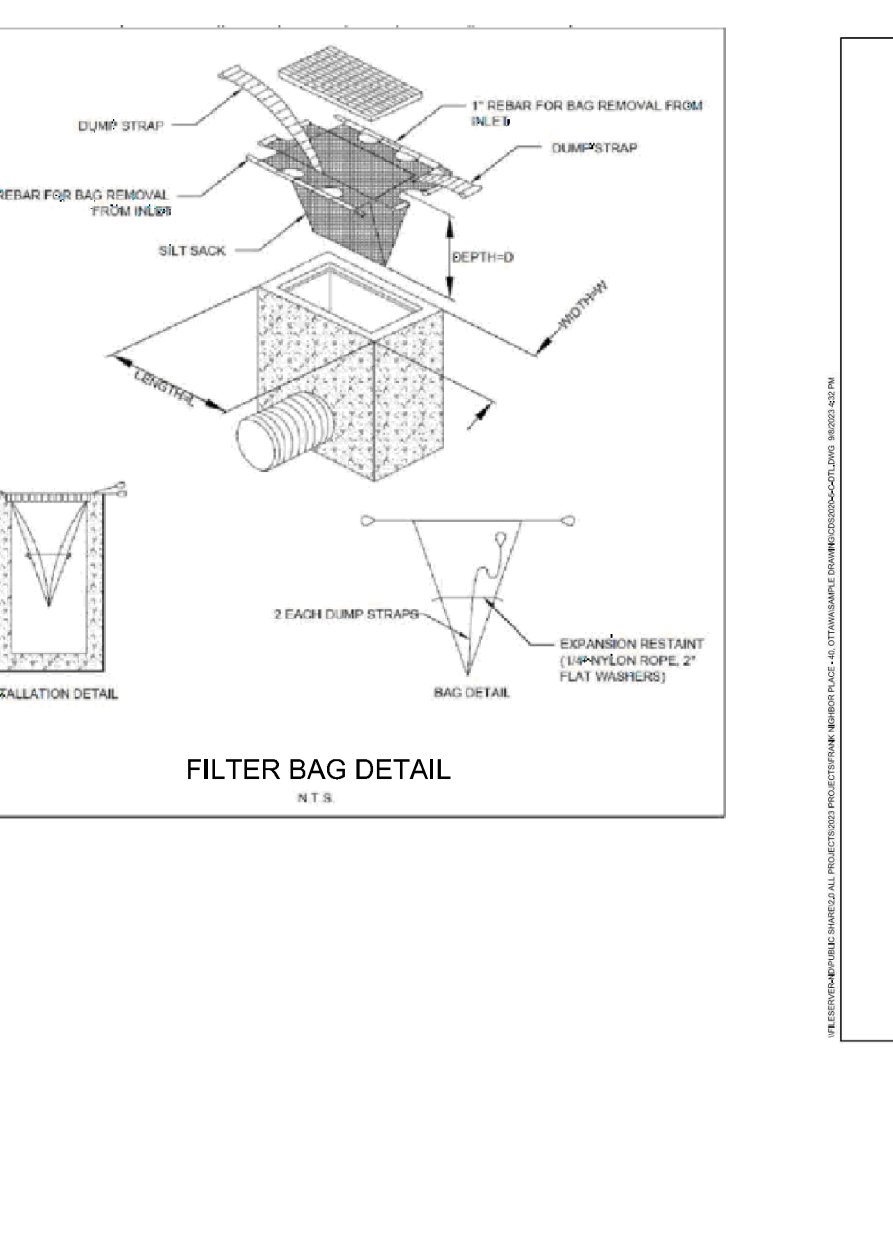
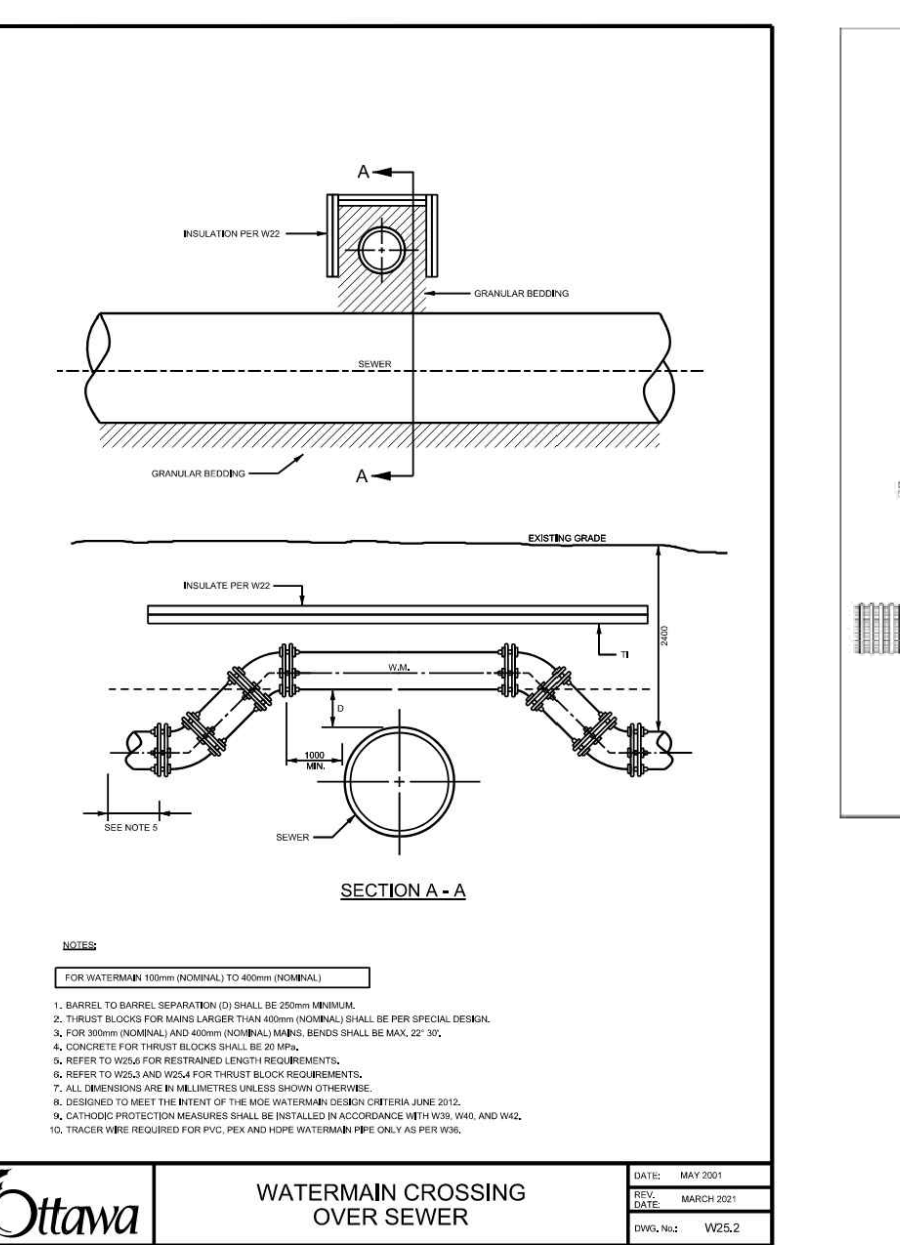
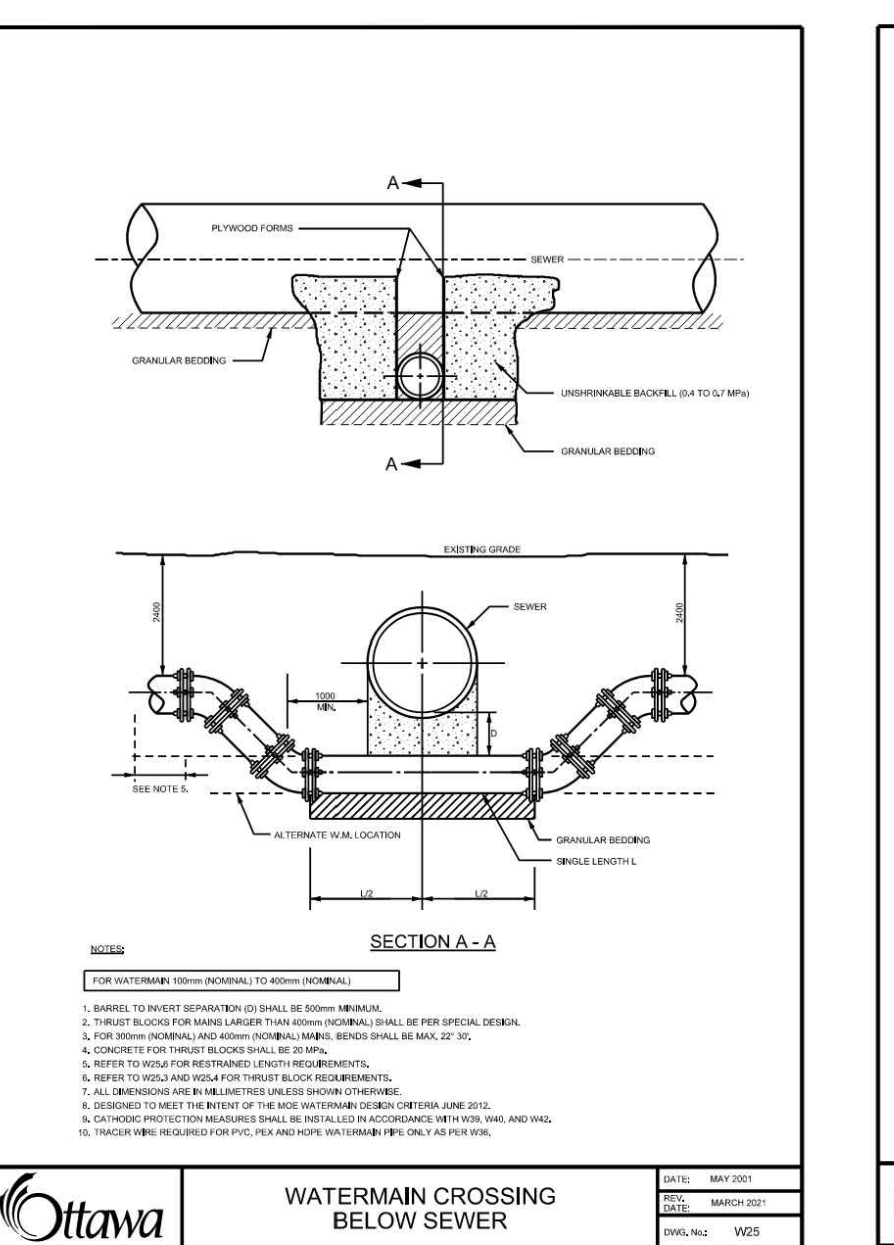
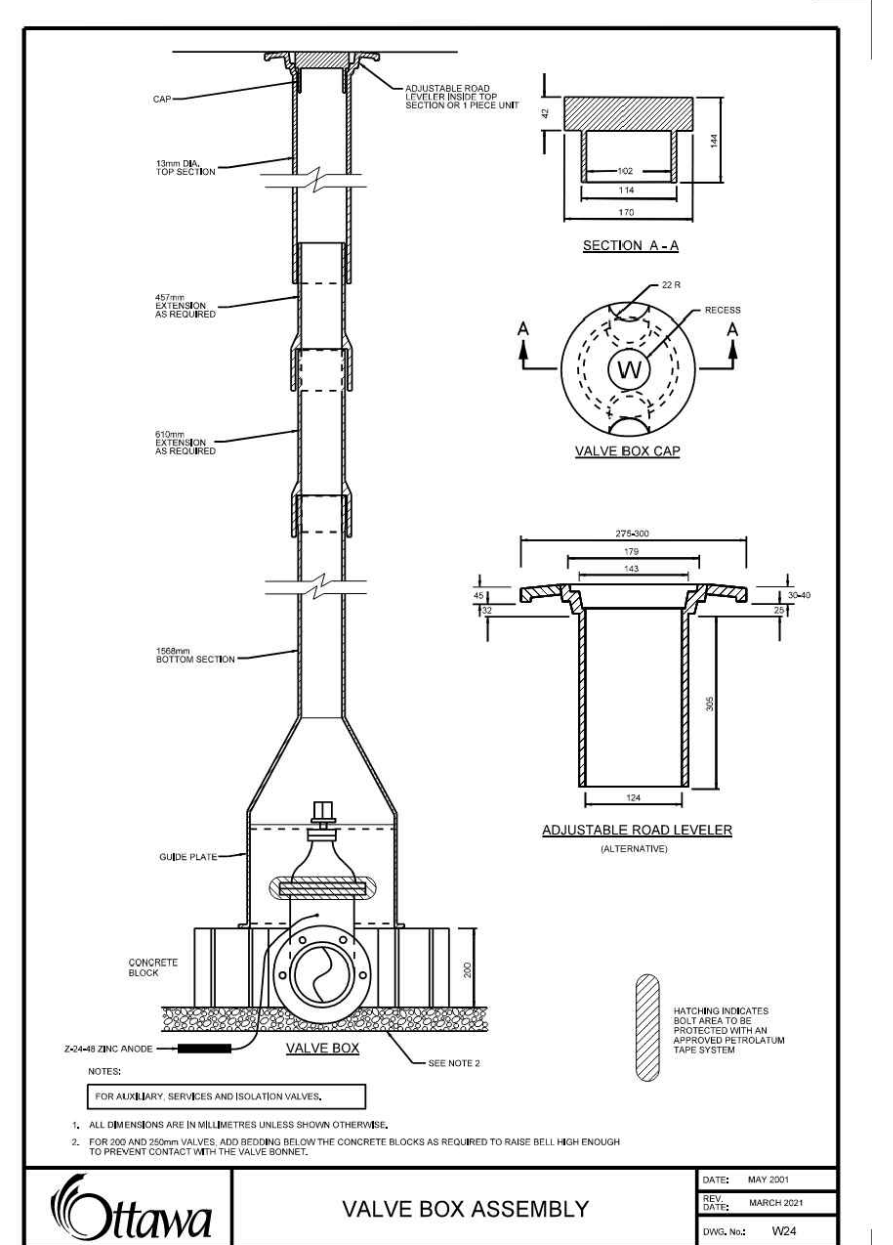
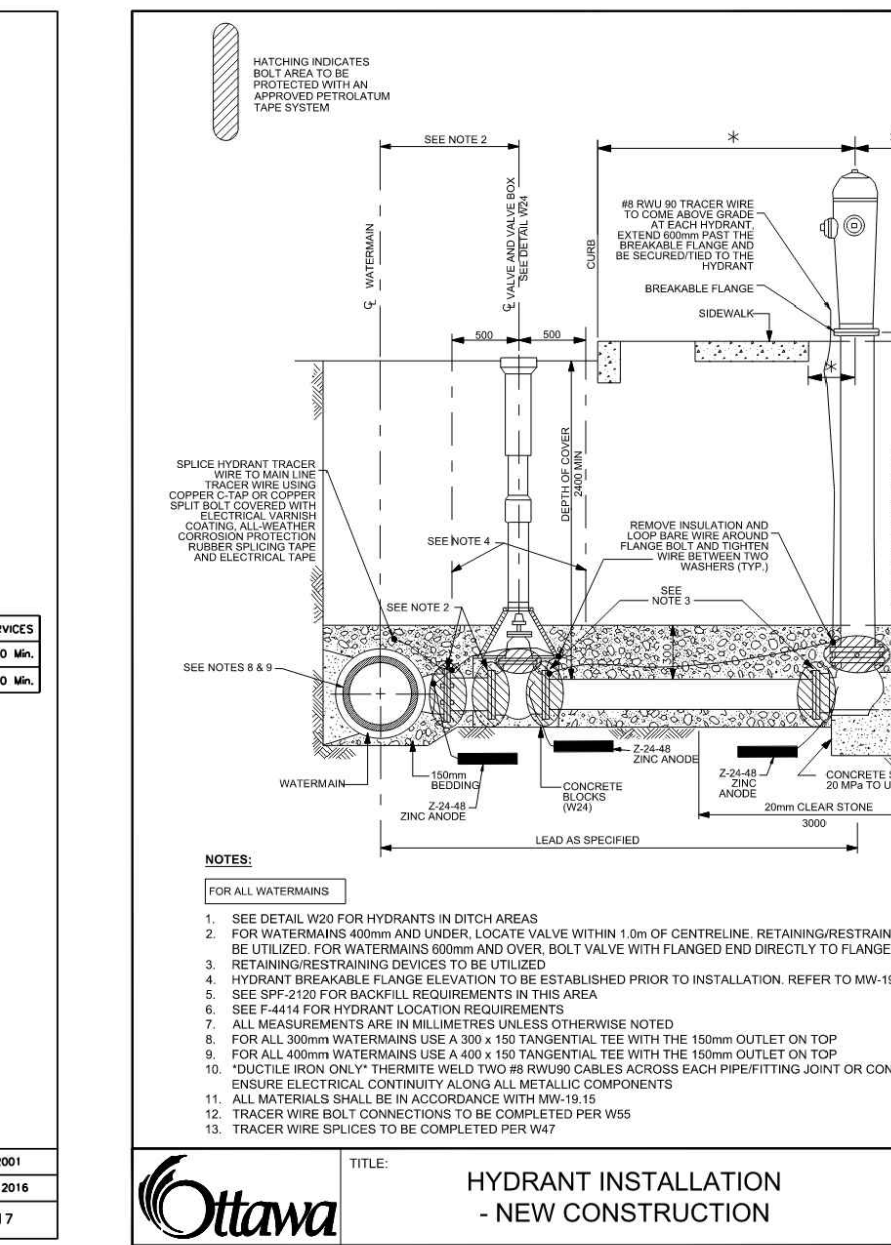
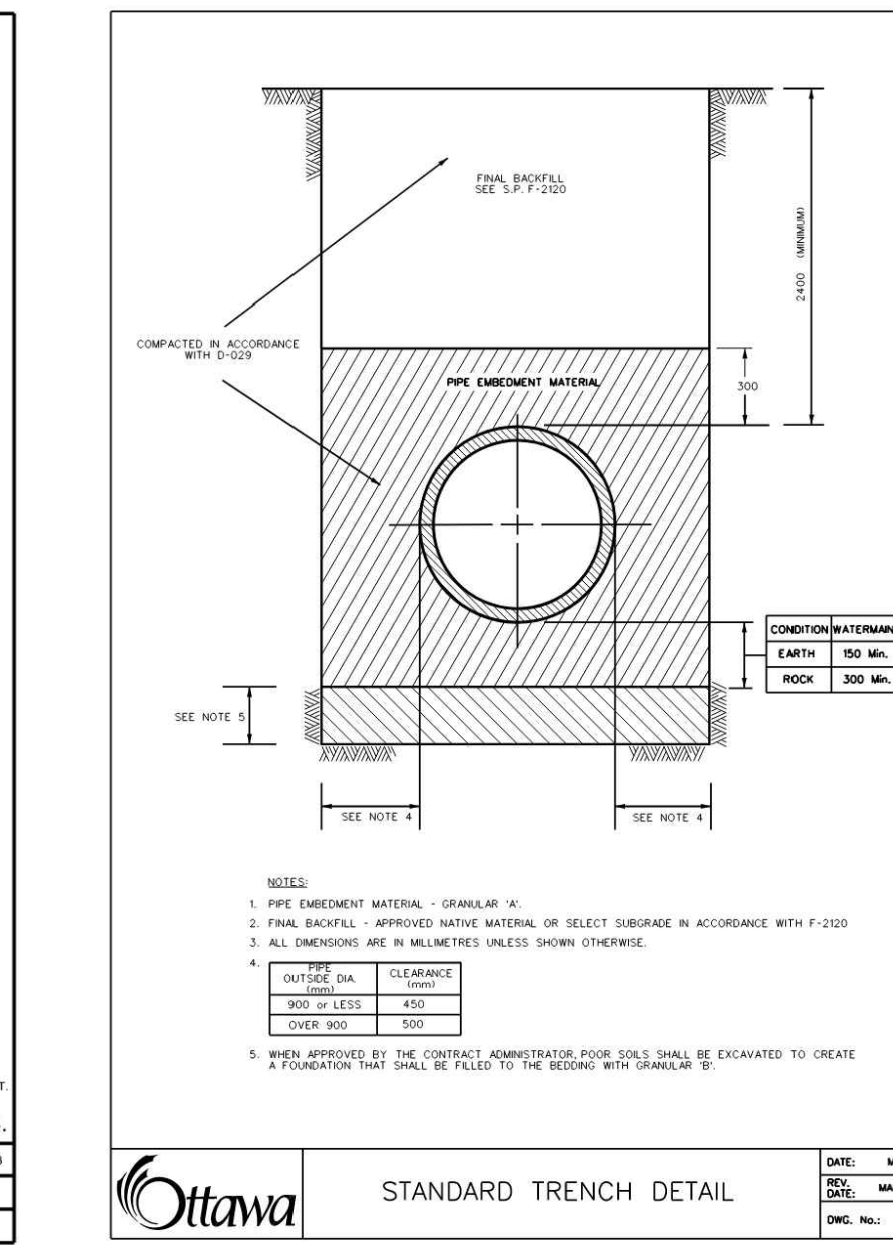
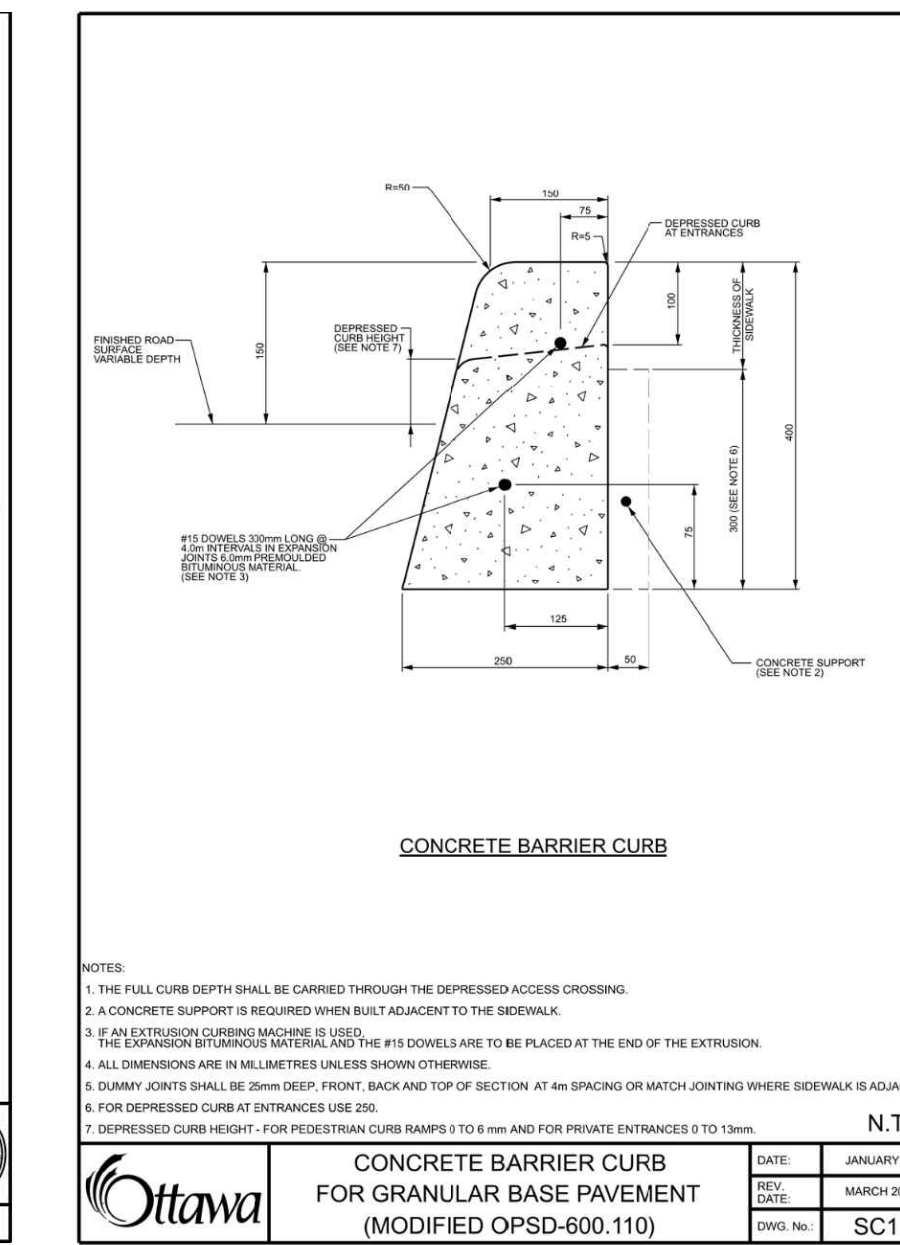
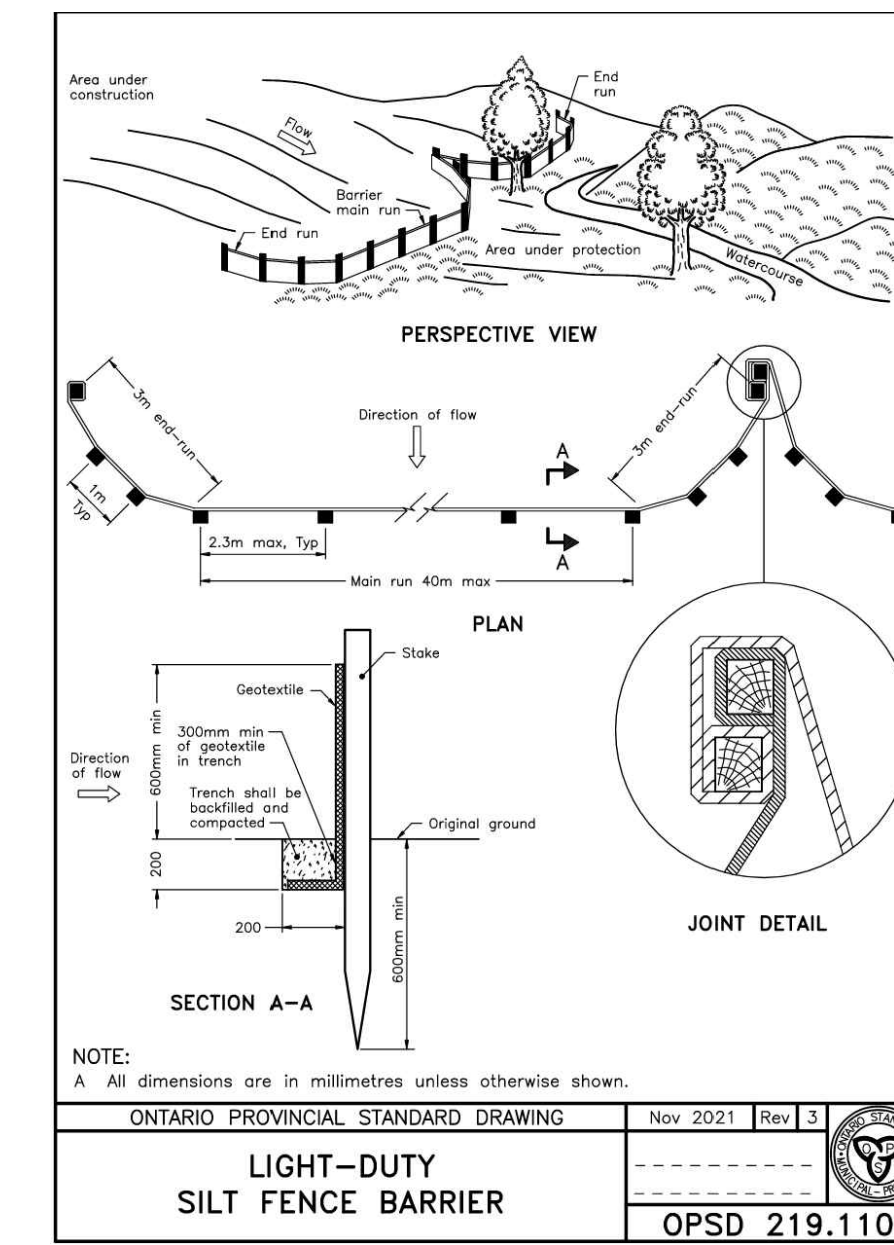
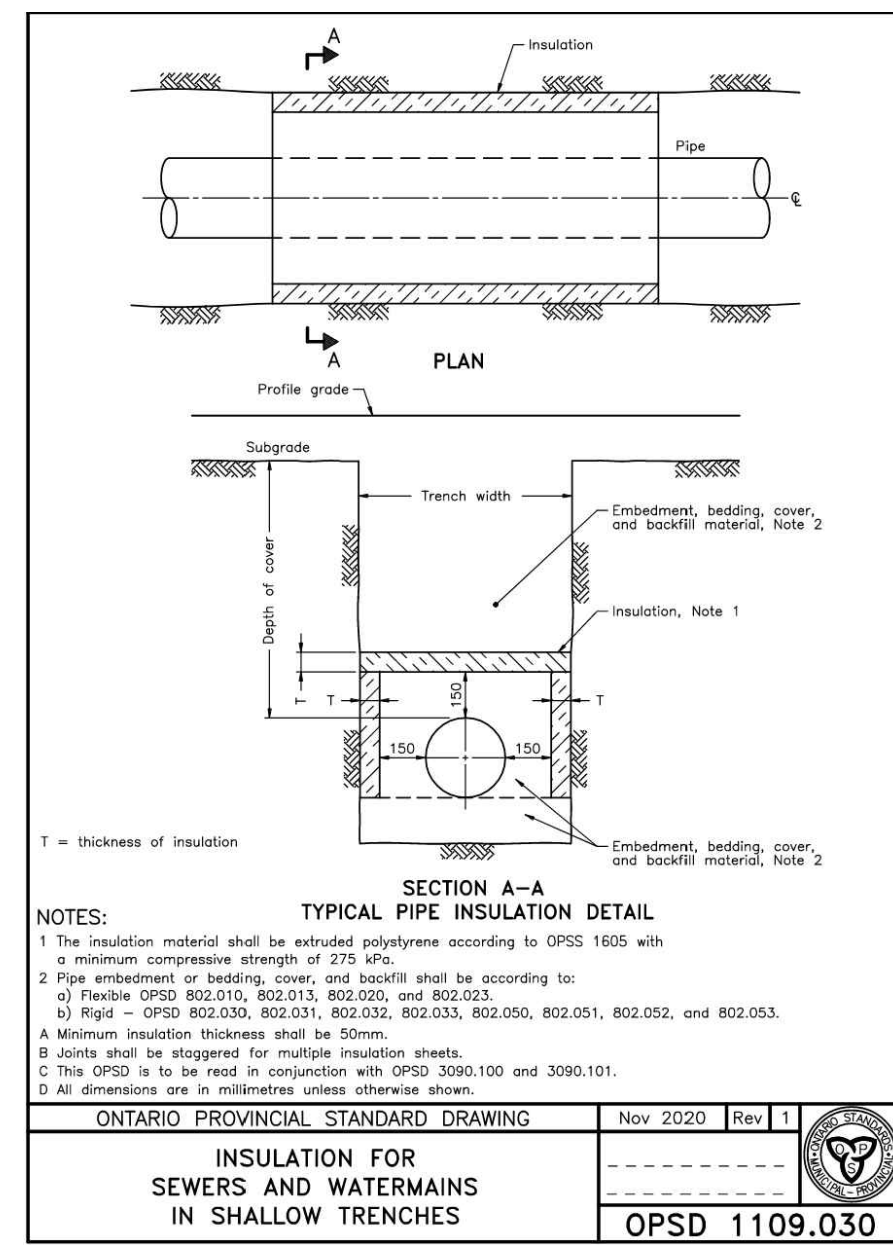
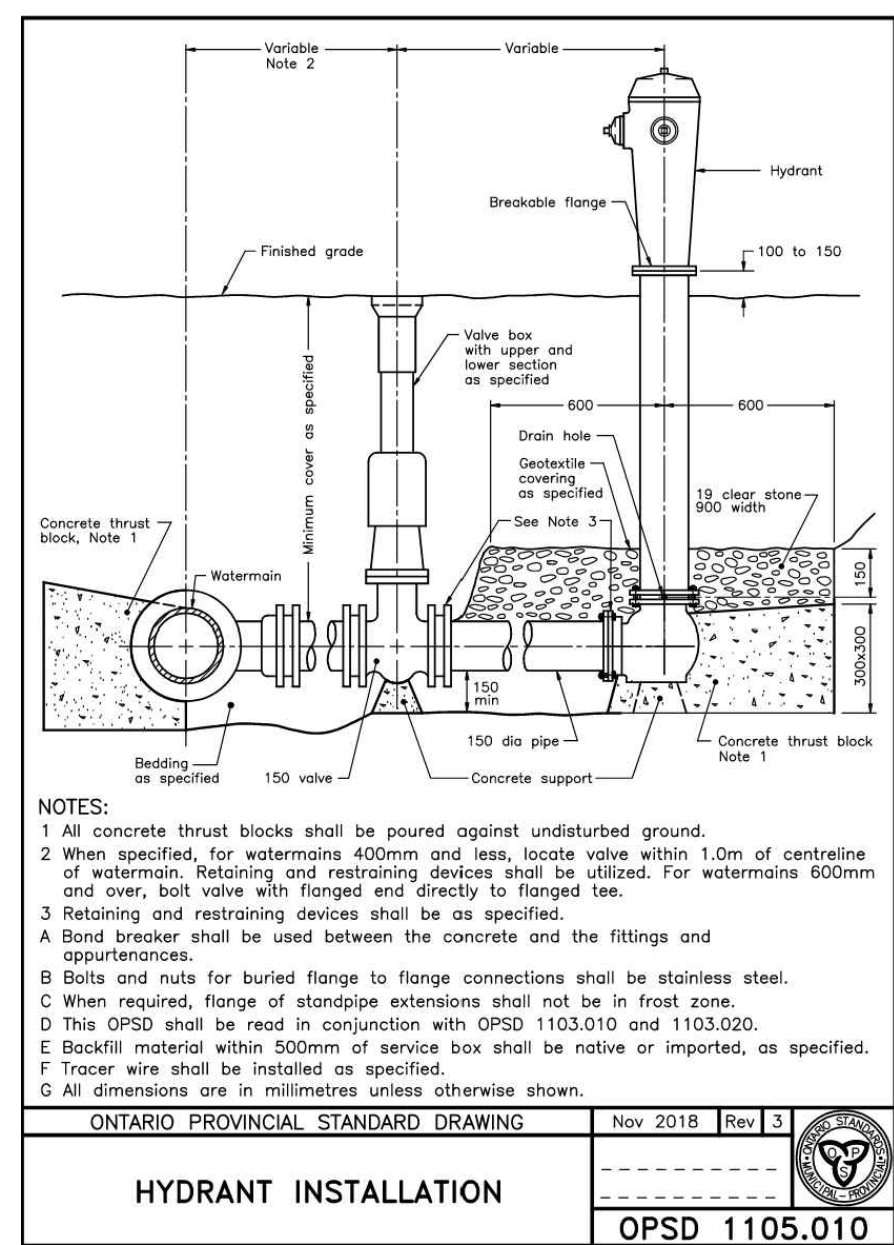

CDS PMSU2020-C-C DESIGN NOTES	
<p>1. ALL DIMENSIONS ARE IN MILLIMETRES UNLESS OTHERWISE SHOWN.</p> <p>2. ALL DIMENSIONS ARE IN MILLIMETRES UNLESS OTHERWISE SHOWN.</p> <p>3. ALL DIMENSIONS ARE IN MILLIMETRES UNLESS OTHERWISE SHOWN.</p> <p>4. ALL DIMENSIONS ARE IN MILLIMETRES UNLESS OTHERWISE SHOWN.</p> <p>5. ALL DIMENSIONS ARE IN MILLIMETRES UNLESS OTHERWISE SHOWN.</p> <p>6. ALL DIMENSIONS ARE IN MILLIMETRES UNLESS OTHERWISE SHOWN.</p> <p>7. ALL DIMENSIONS ARE IN MILLIMETRES UNLESS OTHERWISE SHOWN.</p> <p>8. ALL DIMENSIONS ARE IN MILLIMETRES UNLESS OTHERWISE SHOWN.</p> <p>9. ALL DIMENSIONS ARE IN MILLIMETRES UNLESS OTHERWISE SHOWN.</p> <p>10. ALL DIMENSIONS ARE IN MILLIMETRES UNLESS OTHERWISE SHOWN.</p> <p>11. ALL DIMENSIONS ARE IN MILLIMETRES UNLESS OTHERWISE SHOWN.</p> <p>12. ALL DIMENSIONS ARE IN MILLIMETRES UNLESS OTHERWISE SHOWN.</p> <p>13. ALL DIMENSIONS ARE IN MILLIMETRES UNLESS OTHERWISE SHOWN.</p> <p>14. ALL DIMENSIONS ARE IN MILLIMETRES UNLESS OTHERWISE SHOWN.</p> <p>15. ALL DIMENSIONS ARE IN MILLIMETRES UNLESS OTHERWISE SHOWN.</p> <p>16. ALL DIMENSIONS ARE IN MILLIMETRES UNLESS OTHERWISE SHOWN.</p> <p>17. ALL DIMENSIONS ARE IN MILLIMETRES UNLESS OTHERWISE SHOWN.</p> <p>18. ALL DIMENSIONS ARE IN MILLIMETRES UNLESS OTHERWISE SHOWN.</p> <p>19. ALL DIMENSIONS ARE IN MILLIMETRES UNLESS OTHERWISE SHOWN.</p> <p>20. ALL DIMENSIONS ARE IN MILLIMETRES UNLESS OTHERWISE SHOWN.</p>	
<p>CONTECH</p> <p>CONTECH ENGINEERING INC.</p> <p>100041590</p> <p>SEP 29, 2023</p> <p>PROVINCE OF ONTARIO</p>	
<p>CDS PMSU2020-C-C</p> <p>IN-LINE CDS</p> <p>STANDARD DETAIL</p>	

NOTE:
THE POSITION OF ALL POLE LINES, CONDUITS, WATERMANS, SEWERS AND OTHER UNDERGROUND AND OVERGROUND UTILITIES AND STRUCTURES IS NOT NECESSARILY SHOWN ON THE CONTRACT DRAWINGS, AND WHERE SHOWN, THE ACCURACY OF THE POSITION OF SUCH UTILITIES AND STRUCTURES IS NOT GUARANTEED. BEFORE STARTING WORK, DETERMINE THE EXACT LOCATION OF ALL SUCH UTILITIES AND STRUCTURES AND ASSUME ALL LIABILITY FOR DAMAGE TO THEM.

OWNER INFORMATION
401 REAL ESTATE TRUST INC.
2225 EAGLE STREET N.
CAMBRIDGE, ONTARIO, N3H 4R7
TED LANCASTER
PHONE: (705) 816-6355
ted.lancaster@401auto.ca

SCALE
1:300

DESIGN
ZA

CHECKED
FST

DRAWN
ZA

CHECKED
FST

APPROVED
FST

FOR REVIEW ONLY

1 REVISED PER CITY COMMENTS
SEPT 29/23
FST

NOVATECH
Engineers, Planners & Landscape Architects
Suite 200, 240 Michael Cowpland Drive
Ottawa, Ontario, Canada K2M 1P6
Telephone (613) 254-9643
Facsimile (613) 254-5867
Website www.novatech-eng.com

CITY OF OTTAWA
40 FRANK NIGHBOR PLACE
DRAWING NAME
CIVIL DETAILS PLAN

PROJECT NO. 123002
REV. REV #1
DRAWING NO. 123002-D
PLAN #19002

D07-12-23-0061