

HOMESTEAD LAND HOLDINGS LIMITED

210 CLEARVIEW AVENUE REDEVELOPMENT FUNCTIONAL SERVICING REPORT

SEPTEMBER 24, 2024

COPY





210 CLEARVIEW AVENUE
REDEVELOPMENT
FUNCTIONAL SERVICING REPORT
HOMESTEAD LAND HOLDINGS LIMITED

SERVICING REPORT
COPY

PROJECT NO.: 221-08957-00
CLIENT REF: N/A
DATE: SEPTEMBER 24, 2024
VERSION: 01

WSP
201-1224 GARDINERS ROAD
KINGSTON, ON
CANADA K7P 0G2

T: +1 613 634-7373
F: +1 613 634-3523
WSP.COM

SIGNATURES

PREPARED BY

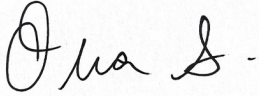

Olivia Simpson
Designer – Kingston

REVIEWED BY



Scott Taylor, P.Eng.
Senior Civil Engineer, Municipal Engineering – Ottawa



WSP Canada Inc. prepared this report solely for the use of the intended recipient, Homestead Land Holdings Limited, in accordance with the professional services agreement. The intended recipient is solely responsible for the disclosure of any information contained in this report. The content and opinions contained in the present report are based on the observations and/or information available to WSP Canada Inc. at the time of preparation. If a third party makes use of, relies on, or makes decisions in accordance with this report, said third party is solely responsible for such use, reliance or decisions. WSP Canada Inc. does not accept responsibility for damages, if any, suffered by any third party as a result of decisions made or actions taken by said third party based on this report. This limitations statement is considered an integral part of this report.

The original of this digital file will be conserved by WSP Canada Inc. for a period of not less than 10 years. As the digital file transmitted to the intended recipient is no longer under the control of WSP Canada Inc., its integrity cannot be assured. As such, WSP Canada Inc. does not guarantee any modifications made to this digital file subsequent to its transmission to the intended recipient.



TABLE OF CONTENTS

1	INTRODUCTION.....	1
2	OBJECTIVE	1
3	EXISTING CONDITIONS	2
3.1	OVERVIEW / EXISTING LAND USE.....	2
3.2	EXISTING ACCESS AND PARKING	2
3.3	EXISTING SANITARY AND WATER SERVICING	2
3.4	EXISTING TOPOGRAPHY & DRAINAGE	2
4	PROPOSED DEVELOPMENT	3
4.1	ADHERENCE TO ZONING AND RELATED REQUIREMENTS.....	3
4.2	GEOTECHNICAL STUDY	3
4.3	ACCESS AND PARKING	3
4.4	SANITARY SERVICING	3
4.4.1	PROPOSED SYSTEM DESCRIPTION	3
4.4.2	DESIGN CRITERIA.....	4
4.4.3	PROPOSED SEWER SIZING	4
4.4.4	ADEQUACY OF MUNICIPAL INFRASTRUCTURE	4
4.5	POTABLE WATER SUPPLY.....	5
4.5.1	PROPOSED SYSTEM DESCRIPTION	5
4.5.2	DESIGN CRITERIA.....	5
4.5.3	FIRE FLOW DEMANDS	6
4.5.4	WATERMAIN MODELLING & RESULTS.....	6
4.5.5	FIRE HYDRANTS	7
4.5.6	RELIABILITY REQUIREMENTS	7
4.5.7	NEED FOR PRESSURE ZONE BOUNDARY MODIFICATION	7
4.6	STORMWATER MANAGEMENT	7
4.7	HYDRO, COMMUNICATIONS, GAS, AND LIGHTING..	8



5	MISCELLANEOUS CITY VERIFICATIONS.....	8
5.1	ENVIRONMENTAL CONSTRAINTS, ENVIRONMENTALLY SIGNIFICANT AREAS, WATERCOURSES, AND MUNICIPAL DRAINS.....	8
5.2	IMPACTS TO PRIVATE SERVICES	8
6	APPROVAL AND PERMIT REQUIREMENTS	8
7	CONCLUSIONS CHECKLIST	8
7.1	CONCLUSIONS AND RECOMMENDATIONS	8
7.2	COMMENTS RECEIVED FROM REVIEW AGENCIES .	8

APPENDICES

A	CIVIL DRAWINGS
B	CITY COMMUNICATION, PRE-CONSULTATION DOCUMENTS & CITY SERVICING CHECKLIST
C	SANITARY SYSTEM CALCULATION
D	WATER SYSTEM CALCULATIONS & MODELLING RESULT

1 INTRODUCTION

WSP Canada Inc. (WSP) was retained by Homestead Land Holdings Limited (Homestead) to complete a Servicing Report for the development of 210 Clearview Avenue (the site) located in Ottawa, Ontario (See Figure 1). The purpose of this report is to summarize the servicing requirements for the Site Plan Control Agreement Application, including but not limited to the following:

- Transportation System
- Sanitary Servicing
- Potable Water Supply
- Stormwater Management
- Utility Servicing
- Approvals



Figure 1: Site Location (Source: Google Earth Pro).

2 OBJECTIVE

The objective of the site servicing report is to meet the requirements for the proposed modification of the site while adhering to the stipulations of all relevant master servicing documents and City of Ottawa servicing design guidelines.

3 EXISTING CONDITIONS

3.1 OVERVIEW / EXISTING LAND USE

The site measures approximately 0.54 ha (5,437 m²) and is located between Clearview Avenue (to the north), 200 Clearview Ave (to the east), Lanark Avenue (to the south), and 281 Clearview Ave (to the west). The entire site is described as Blocks A & D Registered Plan 302828 and Part of Lot 32 Concession A in the City of Ottawa and fronts Clearview Avenue and Lanark Avenue where there is one (1) access corridors on each front.

The property is currently zoned as “R5C – residential Fifth Density Zone” which permits a wide range of residential building forms. Subzone “C” specifically promotes efficient land use and compact form while showcasing newer design approaches. Refer to Appendix A for the Civil Drawings.

3.2 EXISTING ACCESS AND PARKING

The site currently includes parking, greenspace, and pathways. There are two (2) access corridors, the northern access corridor connects 210 Clearview Avenue to Clearview Avenue and the southern access corridor connects 210 Clearview Avenue to Lanark Avenue.

3.3 EXISTING SANITARY AND WATER SERVICING

The existing civil infrastructure near the site is located along Clearview Avenue to the north of the site and Lanark Avenue to the south of the site.

One (1) 225 mm concrete sanitary sewer extends along Clearview Avenue and connects to the sanitary sewer from Ellendale and continues to the east. The sanitary manhole Ex. SANMH201 (located at the northern access corridor to Clearview Avenue) is reported (based on as-built mark-ups provided by Farley, Smith & Denis Surveying Ltd.) to have a west pipe invert elevation of 56.37 m. One (1) 250 mm PVC sanitary sewer extends along Lanark Avenue and appears to gravity drain from west to east, across Lanark Avenue to Ellendale Crescent to the north.

One (1) 200 mm UCI watermain extends along Clearview Avenue and one (1) 300 mm PVC watermain extends along Lanark Avenue, as per the City of Ottawa web mapping (GeoOttawa). It should be noted that the topographic and utility drawing measured a 150 mm main along Lanark Avenue. Similar to the sanitary sewers, watermains are located near the northern (along Clearview Avenue) and southern (along Lanark Avenue) access corridors.

According to GeoOttawa, the nearest fire hydrants to the proposed building are located at the north-east and south-east corners of the existing parking lot within the City Right-Of-Way (ROW). An additional fire hydrant is located at the south-east corner of the site.

Refer to **Appendix A** (Civil Drawings) for information related to existing services.

3.4 EXISTING TOPOGRAPHY & DRAINAGE

The topographic survey (carried out on February 8, 2022, by Farley, Smith & Denis Surveying Ltd.) shows split drainage with flows travelling to north-west and south-east corners of the property, with ground elevations ranging from 59.22 m to 61.53 m.

According to the topographic survey, it appears that stormwater sheet flows off the site to Clearview and Lanark Avenues. From here, surface inlets capture the stormwater in the municipal right of way and route it eastward along Clearview and Lanark Avenues via municipal storm sewers (375-900 mm diameter).

4 PROPOSED DEVELOPMENT

The proposed development includes a new 25-storey multi-residential apartment building with two-storey underground parking. The development will accommodate 184 residential units, including amenity space, and private balconies. The construction of this development will not be carried out in phases.

The following studies have been completed to support development on this site:

- Geotechnical Investigation - Proposed High-Rise Building – 210 Clearview Avenue Ottawa, Ontario (Paterson Group Inc. | Report, Dated July 12, 2022)
- Phase I Environmental Site Assessment (Paterson Group Inc. | Report dated July 15, 2022)

Pre-consultation with the City of Ottawa was held on February 1st, 2024. Refer to **Appendix B** for provided relevant documentation, including the completed Servicing Report Checklist, and correspondence with the City of Ottawa related to the design.

4.1 ADHERENCE TO ZONING AND RELATED REQUIREMENTS

The proposed property use will be in conformance with zoning and related requirements prior to approval and construction and is understood to be in conformance with current zoning.

4.2 GEOTECHNICAL STUDY

A geotechnical investigation report has been prepared by Paterson Group (Report PG6283-1, July 12, 2022). Its recommendations have been taken into account in the development of the engineering drawings.

4.3 ACCESS AND PARKING

Access to the site will be provided via two (2) laneways. The laneway connected to Clearview Avenue will be 6.0 m wide and will provide access to the underground parking. The laneway connected to Lanark Avenue will be 6.7 m wide and will provide access to the front of the building. The fire access routing will be off Lanark Avenue to the Siamese connection near the front of the building. This access route will be a dead-end without turn around facilities, as the length of the route is less than 90.0 m long, in accordance with the Ontario Building Code 2012 Section 3.2.5.6.

Parking for both bicycles and vehicles will be provided, 250 vehicle spaces and 226 bicycle spaces are currently proposed. Of the 250 vehicle parking spaces, ten (10) are visitor parking above ground, the other 240 spaces are located in the below ground parking levels.

Refer to **Appendix A** for the Civil Drawings.

4.4 SANITARY SERVICING

4.4.1 PROPOSED SYSTEM DESCRIPTION

It is recommended the proposed development is serviced with a 200 mm diameter PVC pipe installed at a 1% slope to Ex. SANMH201. A control maintenance hole will be installed on the property line along Clearview Avenue prior to discharging to the municipal sewer. Refer to Civil Drawings, and detailed calculations in **Appendix A** and **Appendix C**, respectively.

There will be a sump pump located on the lower parking level (P2) which will pump the wastewater to the gravity sewer outlet. There are no forcemains or syphons in the proposed design.

4.4.2 DESIGN CRITERIA

Private sanitary sewers and service laterals for the subject site were designed in accordance with the following publications:

- Sewer Design Guidelines (October 2012) & Technical Bulletins ISTB-2018-01 (2018) | City of Ottawa
- Design Guidelines for Sewage Works (2008) | Ministry of the Environment, Conservation, and Parks

Design sanitary flows and associated peaking factors were calculated using a population/unit-based approach using values summarized in Table 1.

Table 1: Sanitary System - Design Values.

Description	Value Used	Source
Population Density	1.4 persons/1 bedroom unit 2.1 persons/2 bedroom unit	City of Ottawa
Average Daily Flow / Capita	280 L/cap/day	City of Ottawa
Peaking Factor (Harmon)	Min. 2 – Max. 4*	City of Ottawa
Peaking Factor – Correction Factor	0.8	City of Ottawa
Total Extraneous Flow	0.33 L/s/ha	City of Ottawa

Refer to the sanitary sewer design sheet (Appendix C) for calculated Harmon peaking factors.

Based on a review of the geotechnical report (prepared by Paterson Group) there are no local conditions which would warrant the allocation of additional extraneous flows to size the system.

4.4.3 PROPOSED SEWER SIZING

Total sanitary flow for the site was calculated to be 4.21 L/s, corresponding to a population of 425 persons. Refer to **Appendix C** for detailed calculations. Per the City's Sewer Design Guidelines, the sewer lateral should be designed with a minimum diameter of 135 mm, minimum slope of 1.0%. The sanitary sewer lateral size will be confirmed with the mechanical designer during detailed design.

A 150 mm diameter sanitary sewer with a slope of 1.0% is proposed to convey the sanitary flow to Clearview Avenue to achieve design velocities within 0.6 m/s to 3.0 m/s. The sanitary sewer connection has been proposed at the existing MHSA27341 (Ex. SANMH201) within the ROW. Refer to **Appendix A** for the civil drawing package which show the layout and connection location. A control maintenance hole structure will also be provided at the property line.

Steps were introduced into the sewers at all maintenance hole structures to accommodate for hydraulics losses in accordance MECP Design Guidelines of Sewage Works (2008).

4.4.4 ADEQUACY OF MUNICIPAL INFRASTRUCTURE

It was confirmed by the City (via email dated September 2, 2022), that the receiving sanitary sewer on Clearview Avenue has sufficient capacity for the proposed development (4.26 L/s). The correspondence has been provided in **Appendix B**.

4.5 POTABLE WATER SUPPLY

4.5.1 PROPOSED SYSTEM DESCRIPTION

Per the City of Ottawa’s Water Distribution Guidelines, the site is required to be serviced with two (2) watermain connections for redundancy as the average day demand is greater than 50 m³/day (0.58 L/s).

The 200 mm diameter water service along Clearview Avenue is a dead-end main and therefore, given the underground parking garage structure area and site plan layout, a dual feed (each 200 mm diameter) from Lanark Avenue is proposed. Based on written communication provided by the City of Ottawa (on May 30th, 2023), it is understood that two (2) services will be permitted for this development.

Refer to **Appendix B** for associated correspondence and **Appendix A** for the Civil Drawings that show the servicing layout and connection locations.

4.5.2 DESIGN CRITERIA

Private watermains and water services for the subject site were designed in accordance with the following publications:

- Ottawa Design Guidelines – Water Distribution (July 2010) & Technical Bulletins | City of Ottawa
- Design Guidelines for Drinking-Water Systems (2008) | Ministry of the Environment, Conservation, and Parks

Domestic water demands and associated peaking factors were calculated using a population/unit-based approach using values summarized in Table 2. Refer to Table 3 for the calculated domestic water demands from the development.

Table 2: Domestic Demand Design Values.

DESCRIPTION	VALUE USED	SOURCE
Population Density	1.4 persons/1 bedroom unit 2.1 persons/2 bedroom unit	City of Ottawa
Average Daily Flow / Capita	280 L/cap/day	City of Ottawa
Peaking Factor	Maximum Daily Demand (MDD): 2.5 Maximum Hourly Demand (MHD): 2.2	Table 4.2 City of Ottawa Water Distribution Design Guidelines (July 2010).

Table 3: Calculated Domestic Water Demands.

	AVERAGE DAILY FLOW (L/S)	MAXIMUM DAILY FLOW, MDD (L/S)	MAXIMUM HOURLY DEMAND, MHD (L/S)
Residential Units	1.13	2.83	6.22
Amenity Space	0.04	0.09	0.16
Total	1.17 L/s	2.92 L/s	6.38 L/s

Refer to **Appendix D** for detailed water demand calculations.

4.5.3 FIRE FLOW DEMANDS

Required fire flow for the proposed development was determined in accordance with the following publication.

- Water Supply for Public Fire Protection (1999) | Fire Underwriters Survey (FUS)

The FUS fire flow was first calculated, as it is typically the governing flow of the two methods. Based on the Architect's building design drawings, WSP has used the following inputs to complete the FUS calculation:

- Construction type: non-combustible (C=0.80)
- Protected or unprotected openings: protected vertical openings (Area = largest floor area + 25% of each 2 adjoining floors)
- Occupancy and contents: limited combustible (-15%)
- Automatic sprinkler protection (-50%):
 - Automatic sprinkler protection designed and installed in accordance with NFPA 13 (-30%)
 - Standard Water Supply (-10%)
 - Fully supervised system (-10%)
- North exposure: 20.1-30 m separation (+10%)

Given these inputs, the required fire flow was calculated to be 83.3 L/s. Refer to **Appendix D** for detailed fire flow demand calculations.

4.5.4 WATERMAIN MODELLING & RESULTS

In order to appropriately size the proposed watermain on the site a WaterGEMS (version 10.03.01.08) steady-state hydraulic model was constructed.

The model layout was based on the proposed watermain configuration detailing the Civil design drawings (refer to **Appendix A**). It was assumed that the watermain profile is 2.4 m below proposed finished grade.

The model was set up to demonstrate appropriate level of service for the development under a variety of typical design demand scenarios. Three (3) scenarios were simulated to confirm adequacy of the proposed watermain design. All scenarios have corresponding requirements for residual pressures (under specific demands) in the system which are dictated by the City water distribution design guidelines. Refer to Table 4 for a summary of model scenarios, assigned demands, and associated pressure objectives.

Table 4: Watermain Pressure and Demand Objectives.

ID	SCENARIOS	DEMANDS	SYSTEM RESIDUAL PRESSURE THRESHOLDS
1	Average Daily Demand (ADD)	1.16 L/s	505 kPa (73.24 PSI)
2	Maximum Hourly Demand (MHD)	2.90 L/s	Min. 505 kPa (73.24 PSI)
3	Maximum Daily Demand + Fire Flow (MDD+FF)	89.64 L/s	Min. 140 kPa (20 PSI)

Boundary conditions for WSP's water model were set through specifying of hydraulic grade line (HGL) elevations, represented through water levels in reservoirs at the connections to the municipal water distribution system. Refer to Table 5 for HGL elevations provided by the City of Ottawa (refer to **Appendix B**). It should be noted that watermain boundary condition results provided by the City on September 22nd, 2022, were based on a dual municipal service connection to the 300 mm diameter watermain on Lanark Avenue relative to the site's full demand.

Table 5: Water Model Boundary Conditions.

SCENARIOS	HGL @ LANARK AVENUE
Assumed Average Watermain Elevation	58.20 m
Minimum HGL	108.6 m
Maximum HGL	115.1 m
MDD+FF	109.9 m

The proposed design was found to satisfy each of the pressure objectives noted in Table 4. The governing scenario used to size the system was Scenario #3 (Maximum Daily + Fire Flow Demand) which yielded the highest demands. Available fire flows throughout the private main were found to exceed FUS requirements (Scenario #3). The maximum available fire flow within the private main was simulated to provide flow to meet the demand criteria of 89.64 L/s with available pressure of 73 PSI. Therefore, it is expected that the available flow and pressure would be adequate to service the site. Based on the results, domestic and fire demands can be serviced within the City's pressure boundaries. Refer to **Appendix D** for water modelling results.

4.5.5 FIRE HYDRANTS

According to GeoOttawa, the nearest fire hydrants to the proposed building are located at the north-east and south-east corners of the existing parking lot within the City Right-Of-Way (ROW). Per Section 3.2.5 of the OBC, these hydrants are within the maximum spacing of the following:

- 45.0 m from the hydrants to ideal pumping truck parking locations,
- 45.0 m from the ideal pumping truck parking locations to building principal entrances, and
- 90.0 m from any fire department connection (i.e. Siamese connection).

4.5.6 RELIABILITY REQUIREMENTS

A total of two (2) shut off valves are provided. One (1) shut off valve is provided for each connection off of Lanark Avenue at the site boundaries. In addition, an isolation valve will be included to avoid a vulnerable service area as per the Ottawa Design Guidelines - Water Distribution, WDG001, July 2010 Clause 4.3.1 Configuration.

4.5.7 NEED FOR PRESSURE ZONE BOUNDARY MODIFICATION

There is no need for a pressure zone boundary modification.

4.6 STORMWATER MANAGEMENT

Refer to the Stormwater Management Report, prepared by WSP, Project 221-08957-00 for details related to the drainage, storm sewers, stormwater management, erosion and sediment control, foundation drainage, etc.

4.7 HYDRO, COMMUNICATIONS, GAS, AND LIGHTING

Hydro, communications, gas, and lighting will be provided as part of the proposed development and will be designed by others in accordance with the applicable codes/standards. Details related to the servicing from these utilities will be completed in the detailed design phase of the project.

5 MISCELLANEOUS CITY VERIFICATIONS

5.1 ENVIRONMENTAL CONSTRAINTS, ENVIRONMENTALLY SIGNIFICANT AREAS, WATERCOURSES, AND MUNICIPAL DRAINS

There are no watercourses, municipal drains, or environmentally significant areas on the site. The building program proposed for the site is not subject to any restrictions associated with the surrounding lands.

There are no previously identified environmental constraints that impact the servicing design in order to preserve the physical condition of watercourses, vegetation, or soil cover, or to manage water quantity or quality.

There is no known need for special considerations related to existing site conditions.

5.2 IMPACTS TO PRIVATE SERVICES

There are no existing domestic private services (i.e. septic system and well) located on the site, nor are there neighbouring properties using these private services.

6 APPROVAL AND PERMIT REQUIREMENTS

The proposed development is subject to site plan approval and building permit approval. No approvals related to municipal drains are required. No permits or approvals are anticipated to be required from the Ontario Ministry of Transportation, Ministry of the Environment, Conservation, and Parks, National Capital Commission, Parks Canada, Public Works and Government Services Canada, or any other provincial or federal regulatory agency.

7 CONCLUSIONS CHECKLIST

7.1 CONCLUSIONS AND RECOMMENDATIONS

It is concluded that the proposed development can meet all provided servicing constraints and associated requirements. It is recommended that this report be submitted to the City of Ottawa in support of the application for site plan approval.

7.2 COMMENTS RECEIVED FROM REVIEW AGENCIES

Minutes from the pre-application meeting held on February 1st, 2024, with the City of Ottawa are provided in **Appendix B**.

APPENDIX

A

CIVIL DRAWINGS



GENERAL

- DRAWINGS TO BE READ IN CONJUNCTION WITH ARCHITECTURAL DRAWINGS.
- ALL SERVICES, MATERIALS, CONSTRUCTION METHODS AND INSTALLATIONS SHALL BE IN ACCORDANCE WITH THE LATEST STANDARDS AND REGULATIONS OF THE: CITY OF OTTAWA STANDARD SPECIFICATIONS AND DRAWINGS, ONTARIO PROVINCIAL SPECIFICATION STANDARD SPECIFICATION (OPSS) AND ONTARIO PROVINCIAL STANDARD DRAWINGS (OPSD), UNLESS OTHERWISE SPECIFIED, TO THE SATISFACTION OF THE CITY AND THE CONSULTANT.
- THE POSITION OF EXISTING POLE LINES, CONDUITS, WATERMAINS, SEWERS AND OTHER UNDERGROUND AND ABOVEGROUND UTILITIES, STRUCTURES AND APPURTENANCES IS NOT NECESSARILY SHOWN ON THE CONTRACT DRAWING, AND WHERE SHOWN, THE ACCURACY OF THE POSITION OF SUCH UTILITIES AND STRUCTURES IS NOT GUARANTEED. PRIOR TO CONSTRUCTION, THE CONTRACTOR SHALL SATISFY THEMSELVES OF THE EXACT LOCATION OF ALL SUCH UTILITIES AND STRUCTURES AND SHALL ASSUME ALL LIABILITY FOR DAMAGE TO THEM DURING THE COURSE OF CONSTRUCTION. ANY RELOCATION OF EXISTING UTILITIES REQUIRED BY THE DEVELOPMENT OF SUBJECT LANDS IS TO BE UNDERTAKEN AT CONTRACTOR'S EXPENSE.
- THE CONTRACTOR MUST NOTIFY ALL EXISTING UTILITY COMPANY OFFICIALS FIVE (5) BUSINESS DAYS PRIOR TO START OF CONSTRUCTION AND HAVE ALL EXISTING UTILITIES AND SERVICES LOCATED IN THE FIELD OR EXPOSED PRIOR TO THE START OF CONSTRUCTION, INCLUDING BUT NOT LIMITED TO POWER, COMMUNICATION AND GAS LINES.
- ALL TRENCHING AND EXCAVATIONS TO BE IN ACCORDANCE WITH THE LATEST REVISIONS OF THE OCCUPATIONAL HEALTH AND SAFETY ACT AND REGULATIONS FOR CONSTRUCTION PROJECTS AND AS PER THE RECOMMENDATIONS INCLUDED IN THE FOLLOWING GEOTECHNICAL REPORT:
 - REPORT PG6283-1 PREPARED PATERSON GROUP, DATED JULY 12, 2022 AND TITLED "GEOTECHNICAL INVESTIGATION - PROPOSED HIGH-RISE BUILDING - 210 CLEARVIEW, OTTAWA, ONTARIO".
- REFER TO ARCHITECTS PLANS FOR BUILDING DIMENSIONS, LAYOUT AND REMOVALS. REFER TO LANDSCAPE PLAN FOR LANDSCAPED DETAILS AND OTHER RELEVANT INFORMATION. ALL INFORMATION SHALL BE CONFIRMED PRIOR TO COMMENCEMENT OF CONSTRUCTION.
- TOPOGRAPHIC SURVEY COMPLETED AND PROVIDED BY FARLEY, SMITH & DENIS SURVEYING LTD. DATED FEBRUARY 8, 2022. ALL ELEVATIONS ARE GEODETIC AND UTILIZE METRIC UNITS. VERIFY THAT JOB BENCHMARKS HAVE NOT BEEN ALTERED OR DISTURBED.
- ALL GROUND SURFACES SHALL BE EVENLY GRADED WITHOUT PONDING AREAS AND WITHOUT LOW POINTS EXCEPT WHERE APPROVED SWALE OR CATCH BASIN OUTLETS ARE PROVIDED.
- ALL EDGES OF DISTURBED PAVEMENT SHALL BE SAW CUT TO FORM A NEAT AND STRAIGHT LINE PRIOR TO PLACING NEW PAVEMENT. PAVEMENT REINSTATEMENT SHALL BE WITH STEP JOINTS OF 500mm WIDTH MINIMUM PER DETAIL 1/C01.
- ALL DISTURBED AREAS OUTSIDE PROPOSED GRADING LIMITS ARE TO BE RESTORED TO ORIGINAL ELEVATIONS AND CONDITIONS UNLESS OTHERWISE SPECIFIED. ALL RESTORATION SHALL BE COMPLETED WITH THE GEOTECHNICAL REQUIREMENTS FOR BACKFILL AND COMPACTION.
- ABUTTING PROPERTY GRADES TO BE MATCHED UNLESS OTHERWISE SHOWN.
- CONTRACTOR SHALL OBTAIN AND PAY FOR ALL NECESSARY PERMITS AND APPROVALS FROM THE MUNICIPAL AUTHORITIES PRIOR TO COMMENCING CONSTRUCTION, INCLUDING WATER PERMIT AND ROAD CUT PERMIT.
- MINIMIZE DISTURBANCE TO EXISTING VEGETATION DURING THE EXECUTION OF ALL WORKS.
- REMOVE FROM SITE ALL EXCESS EXCAVATED MATERIAL UNLESS OTHERWISE DIRECTED FROM THE ENGINEER. EXCAVATE AND REMOVE ALL ORGANIC MATERIAL AND DEBRIS LOCATED WITHIN THE PROPOSED BUILDING, PARKING AND ROADWAY LOCATIONS.
- AT PROPOSED UTILITY CONNECTION POINTS AND CROSSINGS (I.E. STORM SEWER, SANITARY SEWER, WATER, ETC.) THE CONTRACTOR SHALL DETERMINE THE PRECISE LOCATION AND DEPTH OF EXISTING UTILITIES AND REPORT ANY DISCREPANCIES OR CONFLICTS TO THE ENGINEER BEFORE COMMENCING WORK.
- CONTRACTOR TO OBTAIN POST-CONSTRUCTION TOPOGRAPHIC SURVEY, COMPLETED BY OLS OR P. ENG CONFIRMING COMPLIANCE WITH DESIGN GRADING AND SERVICING. SURVEY IS TO INCLUDE LOCATION AND INVERTS FOR BURIED UTILITIES.
- ABIDE BY RECOMMENDATIONS OF GEOTECHNICAL REPORT. REPORT ANY VARIATIONS IN OBSERVED CONDITIONS FROM THOSE INCLUDED IN REPORT.
- PROVIDE CCTV INSPECTION REPORT FOR ALL SEWERS AND CATCHBASIN LEADS 200mm DIAMETER AND LARGER. REPEAT CCTV INSPECTION FOLLOWING RECTIFICATION OF ANY DEFICIENCIES.
- SEWER SERVICE CONNECTIONS TO FLEXIBLE MAIN SEWER PIPES AND RIGID MAIN SEWERS PIPES SHALL BE PER RESPECTIVE CITY OF OTTAWA STANDARD S11, S11.1, AND S11.2.
- COMMON TRENCHES FOR SERVICING SHALL BE PER CITY OF OTTAWA STANDARD S11.3.
- CONTRACTOR TO FIELD VERIFY AND REPORT TO ENGINEER OF RECORD THE ELEVATION, MATERIAL, AND DIAMETER OF EXISTING UTILITIES AT ALL PROPOSED CONNECTIONS PRIOR TO CONSTRUCTION.

2. WATERMAIN

- ALL WATERMAIN AND WATERMAIN APPURTENANCES, MATERIALS, CONSTRUCTION AND TESTING METHODS SHALL CONFORM TO THE CURRENT CITY OF OTTAWA AND MINISTRY OF ENVIRONMENT, CONSERVATION, AND PARKS WATERWORKS GUIDELINES.
- ALL WATERMAIN 300mm DIAMETER AND SMALLER TO BE POLY VINYL CHLORIDE (PVC) CLASS 150 DR 18 MEETING AWWA SPECIFICATION C900.
- ALL WATERMAIN TO BE INSTALLED AT MINIMUM COVER OF 2.4m BELOW FINISHED GRADE IN ACCORDANCE WITH CITY OF OTTAWA STANDARD W17. WHERE WATERMAINS CROSS OTHER UTILITIES, A MINIMUM 0.30m CLEARANCE SHALL BE MAINTAINED; WHERE WATERMAINS CROSS UNDER OTHER UTILITIES, A MINIMUM 0.50m CLEARANCE SHALL BE MAINTAINED. WHERE THE MINIMUM SEPARATION CANNOT BE ACHIEVED, THE WATERMAIN SHALL BE INSTALLED AS PER CITY OF OTTAWA STANDARDS W25 AND W25.2. WHERE 2.4m MINIMUM DEPTH CANNOT BE ACHIEVED, THERMAL INSULATION SHALL BE PROVIDED AS PER CITY OF OTTAWA STANDARD W22. WHERE A WATERMAIN IS IN CLOSE PROXIMITY TO AN OPEN STRUCTURE, THERMAL INSULATION SHALL BE PROVIDED AS PER CITY OF OTTAWA STANDARD W23.
- CONCRETE THRUST BLOCKS AND MECHANICAL RESTRAINTS ARE TO BE INSTALLED AT ALL TEES, BENDS, HYDRANTS, REDUCERS, ENDS OF MAINS AND CONNECTIONS 100mm AND LARGER, IN ACCORDANCE WITH CITY OF OTTAWA STANDARDS W25.3 & W25.4.
- CATHODIC PROTECTION REQUIRED FOR ALL IRON FITTINGS AS PER CITY OF OTTAWA STANDARD W40 & W42.
- DOMESTIC WATER SERVICES SHALL BE IN ACCORDANCE WITH CITY STANDARD DETAIL W26.
- ALL VALVES AND VALVE BOXES AND CHAMBERS, HYDRANTS, AND HYDRANT VALVES AND ASSEMBLES SHALL BE INSTALLED AS PER CITY OF OTTAWA STANDARD.
- FIRE HYDRANT LOCATION AND INSTALLATION AS PER CITY OF OTTAWA STANDARD W18 & W19. CONTRACTOR TO PROVIDE FLOW TEST AND PAINTING OF NEW HYDRANT IN ACCORDANCE WITH CITY STANDARDS.
- IF WATERMAIN MUST BE DEFLECTED TO MEET ALIGNMENT, ENSURE THAT THE AMOUNT OF DEFLECTION USED IS LESS THAN HALF THAT RECOMMENDED BY THE MANUFACTURER.

3. SANITARY SEWER AND MANHOLES

- ALL SANITARY SEWER, SANITARY SEWER APPURTENANCES AND CONSTRUCTION METHODS SHALL CONFORM TO THE CURRENT CITY OF OTTAWA STANDARDS AND SPECIFICATIONS. PROVIDE CCTV INSPECTION REPORTS FOR ALL NEW SANITARY PIPING. PROVIDE DYE TESTING FOR NEW SERVICES.
- SANITARY SEWER PIPE SIZE 150mm DIAMETER AND GREATER TO BE PVC SDR-35 (UNLESS SPECIFIED OTHERWISE) WITH RUBBER GASKET TYPE JOINTS IN CONFORMANCE WITH CSA B-182.2,3,4.
- SEWER BEDDING AS PER CITY OF OTTAWA DETAIL S6.
- ALL SANITARY MAINTENANCE HOLES 1200mm IN DIAMETER TO BE AS PER OPSD 701.010. FRAME AND COVER TO BE AS PER CITY OF OTTAWA STANDARD S25 AND S24.
- MAINTENANCE HOLE BENCHING AND PIPE OPENING ALTERNATIVES AS PER THE OPSD 701.021
- ANY NEW OR EXISTING SANITARY SEWER (INCLUDING SERVICE LATERALS) WITH LESS THAN 2.0m COVER REQUIRES THERMAL INSULATION AS PER DETAIL 2/C01 OR APPROVED BY THE ENGINEER.

- SANITARY MAINTENANCE HOLE WHICH RESIDE WITHIN 100-YEAR STORMWATER PONDING AREAS SHALL BE EQUIPPED WITH WATER-TIGHT LIDS IN ACCORDANCE WITH CITY STANDARD.

4. STORM SEWERS AND STRUCTURES

- ALL STORM SEWER MATERIALS AND CONSTRUCTION METHODS SHALL CONFORM TO THE CURRENT CITY OF OTTAWA STANDARDS AND SPECIFICATIONS. PROVIDE CCTV INSPECTION REPORTS FOR ALL NEW STORM SEWERS, SERVICES AND CB LEADS.
- STORM SEWERS 450mm DIAMETER AND SMALLER SHALL BE PVC SDR-35, WITH RUBBER GASKET PER CSA A-257.3.
- STORM SEWER LARGER THAN 450mm SHALL BE REINFORCED CONCRETE CLASS 100.
- SEWER BEDDING AS PER CITY OF OTTAWA DETAIL S6.
- ANY NEW OR EXISTING STORM SEWER (INCLUDING SERVICE LATERALS) WITH LESS THAN 2.0m COVER REQUIRES THERMAL INSULATION AS PER DETAIL 2/C01 OR APPROVED BY THE ENGINEER.
- CB IN LANDSCAPE AREAS SHALL BE AS PER CITY OF OTTAWA STANDARD S29, S30 AND S31, UNLESS OTHERWISE SPECIFIED.
- ALL CATCHBASIN LEADS TO BE MINIMUM 200mm DIAMETER AT MINIMUM 1.0% SLOPE UNLESS OTHERWISE SPECIFIED.
- STORM CATCHBASINS AS PER OPSD 705.010 AND FRAME/COVER AS PER CITY STANDARD DRAWINGS S19 UNLESS OTHERWISE NOTED.

5. PARKING LOT AND WORK IN PUBLIC RIGHTS OF WAY

- CONTRACTOR TO REINSTATE ROAD CUTS AS PER CITY OF OTTAWA DETAIL R10.
- CONTRACTOR TO PREPARE SUBGRADE, INCLUDING PROOF ROLLING, TO THE SATISFACTION OF THE GEOTECHNICAL CONSULTANT PRIOR TO THE COMMENCEMENT OF PLACEMENT OF SUB-BASE MATERIAL.
- FILL TO BE PLACED AND COMPACTED PER THE GEOTECHNICAL REPORT REQUIREMENTS.
- CONTRACTOR TO SUPPLY, PLACE AND COMPACT SUB-BASE MATERIAL IN ACCORDANCE WITH THE RECOMMENDATIONS OF THE GEOTECHNICAL CONSULTANT. CONTRACTOR TO PROVIDE CONSULTANT WITH SAMPLES OF SUB-BASE MATERIAL FOR TESTING AND CERTIFICATION FROM THE GEOTECHNICAL CONSULTANT THAT THE MATERIAL MEETS THE GRADATION REQUIREMENTS SPECIFIED IN THE GEOTECHNICAL REPORT.
- BASE MATERIAL TO BE PLACED ONLY UPON APPROVAL BY THE GEOTECHNICAL CONSULTANT OF SUB-BASE PLACEMENT.
- CONTRACTOR TO SUPPLY, PLACE AND COMPACT BASE MATERIAL IN ACCORDANCE WITH THE RECOMMENDATIONS OF THE GEOTECHNICAL CONSULTANT. CONTRACTOR TO PROVIDE CONSULTANT WITH SAMPLES OF BASE MATERIAL FOR TESTING AND CERTIFICATION FROM THE GEOTECHNICAL CONSULTANT THAT THE MATERIAL MEETS THE GRADATION REQUIREMENTS SPECIFIED IN THE GEOTECHNICAL REPORT.
- ASPHALT MATERIAL TO BE PLACED ONLY UPON APPROVAL BY THE GEOTECHNICAL CONSULTANT OF BASE PLACEMENT.
- CONTRACTOR TO SUPPLY, PLACE AND COMPACT ASPHALT MATERIAL IN ACCORDANCE WITH THE RECOMMENDATIONS OF THE GEOTECHNICAL CONSULTANT. CONTRACTOR TO PROVIDE CONSULTANT WITH SAMPLES OF ASPHALT MATERIAL FOR TESTING AND CERTIFICATION FROM THE GEOTECHNICAL CONSULTANT THAT THE MATERIAL MEETS THE REQUIREMENTS SPECIFIED IN THE GEOTECHNICAL REPORT.
- CONTRACTOR IS RESPONSIBLE FOR ESTABLISHING LINE AND GRADE IN ACCORDANCE WITH THE PLANS, AND FOR PROVIDING THE CONSULTANT WITH VERIFICATION PRIOR TO PLACEMENT.
- ALL EXCESS MATERIAL TO BE HAULED OFF-SITE AND DISPOSED OF AT AN APPROVED SITE. SHOULD THE CONTRACTOR DISCOVER ANY HAZARDOUS MATERIAL, CONTRACTOR IS TO NOTIFY CONSULTANT. CONSULTANT TO DETERMINE APPROPRIATE DISPOSAL METHOD/LOCATION.
- PAVEMENT STRUCTURE (MATERIAL TYPES AND THICKNESS) TO BE AS SPECIFIED IN THE GEOTECHNICAL REPORT AND SHOWN ON THE ARCHITECTURAL PLANS.

6. EROSION AND SEDIMENT CONTROL

- ** CONTRACTOR IS RESPONSIBLE FOR ALL INSTALLATION, MONITORING, REPAIR AND REMOVAL OF ALL EROSION AND SEDIMENT CONTROL FEATURES. **
- PRIOR TO START OF CONSTRUCTION:**
 - INSTALL SILT FENCE IN LOCATION SHOWN ON DWG C02.
 - INSTALL FILTER FABRIC OR SILT SACK FILTERS IN ALL THE CATCHBASINS AND MAINTENANCE HOLES TO REMAIN DURING CONSTRUCTION WITHIN THE SITE AS SHOWN ON DWG C02.
 - INSPECT MEASURES IMMEDIATELY AFTER INSTALLATION.
 - DURING CONSTRUCTION:**
 - MINIMIZE THE EXTENT OF DISTURBED AREAS AND THE DURATION OF EXPOSURE AND IMPACTS TO EXISTING GRADING.
 - PERIMETER VEGETATION TO REMAIN IN PLACE UNTIL PERMANENT STORM WATER MANAGEMENT IS IN PLACE. OTHERWISE, IMMEDIATELY INSTALL SILT FENCE WHEN THE EXISTING SITE IS DISTURBED AT THE PERIMETER.
 - PROTECT DISTURBED AREAS FROM OVERLAND FLOW BY PROVIDING TEMPORARY SWALES TO THE SATISFACTION OF THE CONSULTANT. TIE-IN TEMPORARY SWALE TO EXISTING CATCH BASINS AS REQUIRED.
 - PROVIDE TEMPORARY COVER SUCH AS SEEDING OR MULCHING IF DISTURBED AREA WILL NOT BE REHABILITATED WITHIN 30 DAYS.
 - INSPECT SILT FENCES, FILTER FABRIC FILTERS AND CATCH BASIN SUMPS WEEKLY AND WITHIN 24 HOURS AFTER A STORM EVENT. CLEAN AND REPAIR WHEN NECESSARY.
 - SEDIMENT AND EROSION CONTROL PLAN DRAWING TO BE REVIEWED AND REVISED AS REQUIRED DURING CONSTRUCTION.
 - SEDIMENT CONTROL FENCING TO BE INSTALLED AROUND THE BASE OF ALL STOCKPILES.
 - DO NOT LOCATE TOPSOIL PILES AND EXCAVATION MATERIAL CLOSER THAN 2.5m FROM ANY PAVED SURFACE, OR ONE WHICH IS TO BE PAVED BEFORE THE PILE IS REMOVED. ALL TOPSOIL PILES ARE TO BE SEEDING IF THEY ARE TO REMAIN ON-SITE LONG ENOUGH FOR SEEDS TO GROW (LONGER THAN 30 DAYS).
 - CONTROL WIND-BLOWN DUST OFF-SITE BY SEEDING TOPSOIL PILES AND OTHER AREAS TEMPORARILY (PROVIDE WATERING AS REQUIRED AND TO THE SATISFACTION OF THE ENGINEER).
 - NO ALTERNATE METHODS OF EROSION PROTECTION SHALL BE PERMITTED UNLESS APPROVED BY THE CONSULTANT.
 - CITY ROADWAY AND SIDEWALK TO BE CLEANED OF ALL SEDIMENT FROM VEHICULAR TRACKING AS REQUIRED.
 - DURING WET CONDITIONS, TIRES OF ALL VEHICLES/EQUIPMENT LEAVING THE SITE ARE TO BE SCRAPPED.
 - ANY MUD/MATERIAL TRACKED ONTO THE ROAD SHALL BE REMOVED IMMEDIATELY BY HAND OR RUBBER TIRE LOADER.
 - TAKE ALL NECESSARY STEPS TO PREVENT BUILDING MATERIAL, CONSTRUCTION DEBRIS OR WASTE BEING SPILLED OR TRACKED ONTO ABUTTING PROPERTIES OR PUBLIC STREETS DURING CONSTRUCTION AND PROCEED IMMEDIATELY TO CLEAN UP ANY AREAS SO AFFECTED.
 - ALL EROSION CONTROL STRUCTURE TO REMAIN IN PLACE UNTIL ALL DISTURBED GROUND SURFACES HAVE BEEN STABILIZED EITHER BY PAVING OR RESTORATION OF VEGETATIVE GROUND COVER.
 - THE CONTRACTOR SHALL IMPLEMENT BEST MANAGEMENT PRACTICES, TO PROVIDE FOR PROTECTION OF THE AREA DRAINAGE SYSTEM, DURING CONSTRUCTION ACTIVITIES. THE CONTRACTOR ACKNOWLEDGES THAT FAILURE TO IMPLEMENT APPROPRIATE EROSION AND SEDIMENT CONTROL MEASURES MAY BE SUBJECT TO PENALTIES IMPOSED BY ANY APPLICABLE REGULATORY AGENCY.

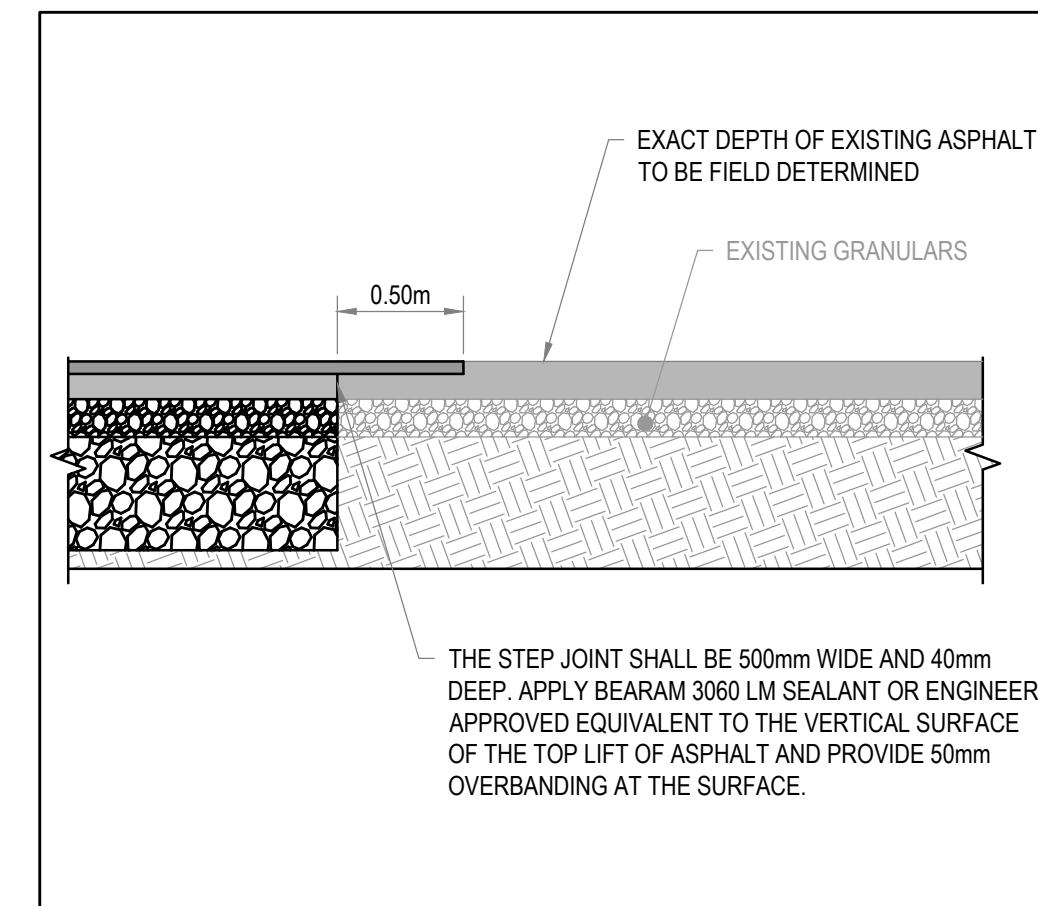

1 TYPICAL STEP CONNECTION
SCALE: 1:30

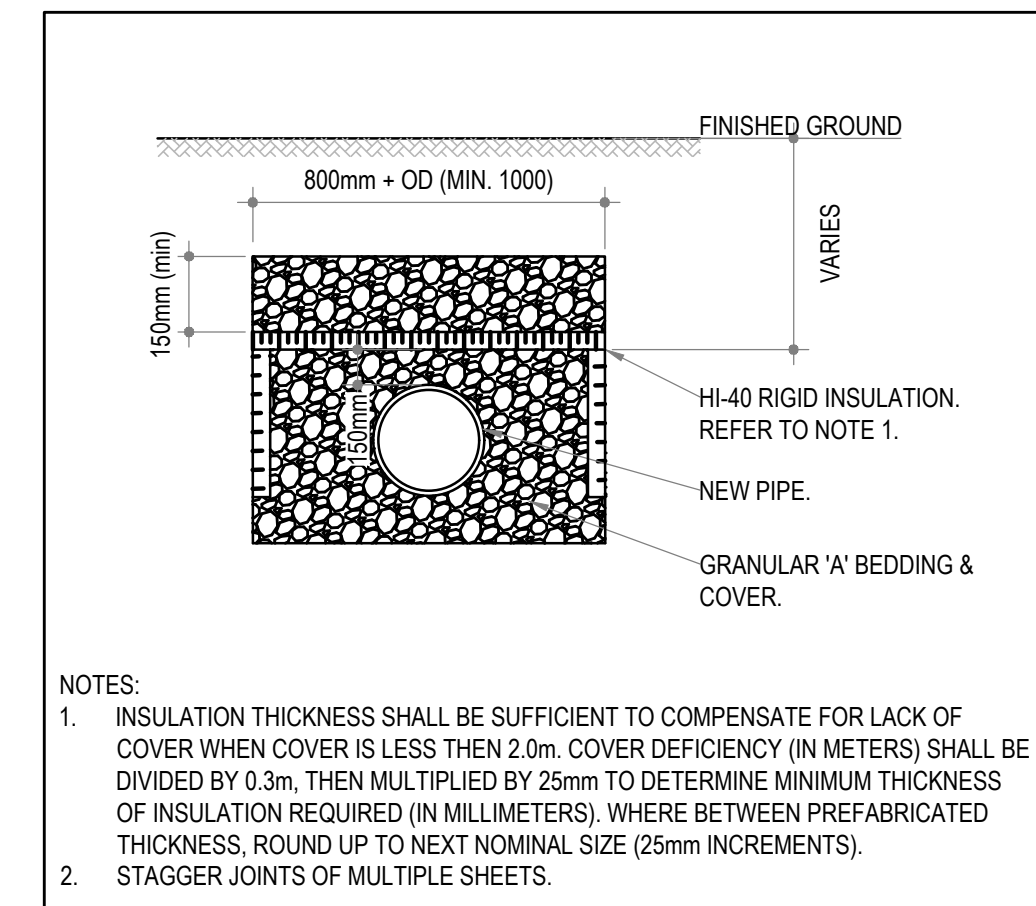

2 FROST PROTECTION DETAIL (SEWERS)
SCALE: 1:20

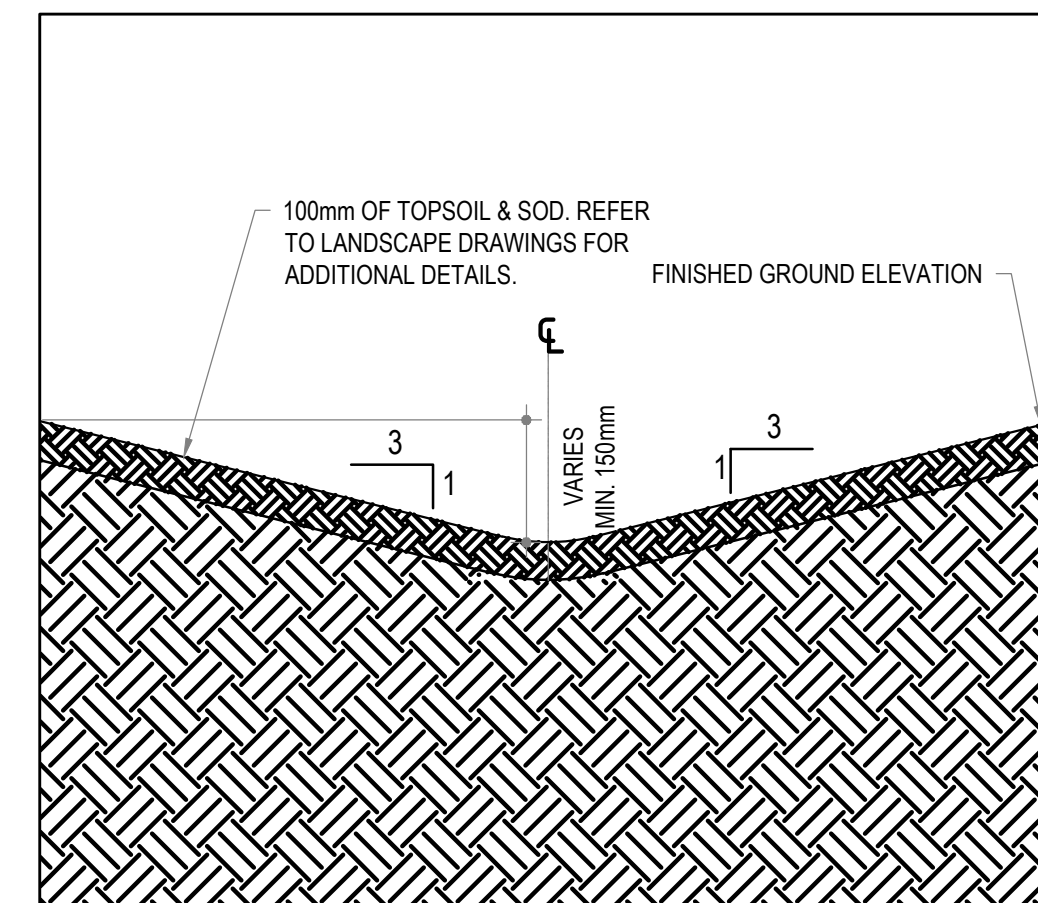

3 TYPICAL SWALE
SCALE: 1:20

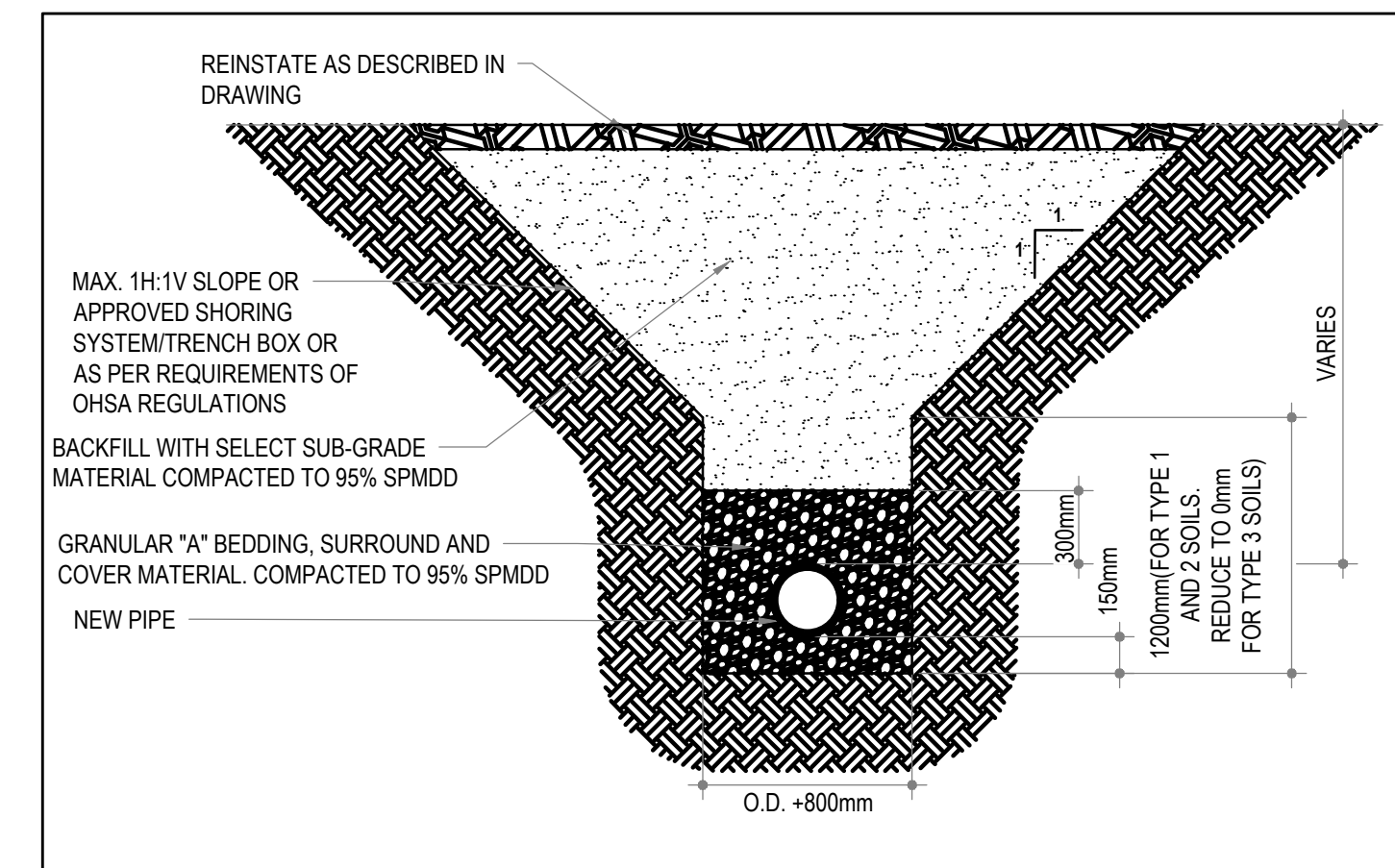

4 TYPICAL TRENCH DETAIL
SCALE: NTS

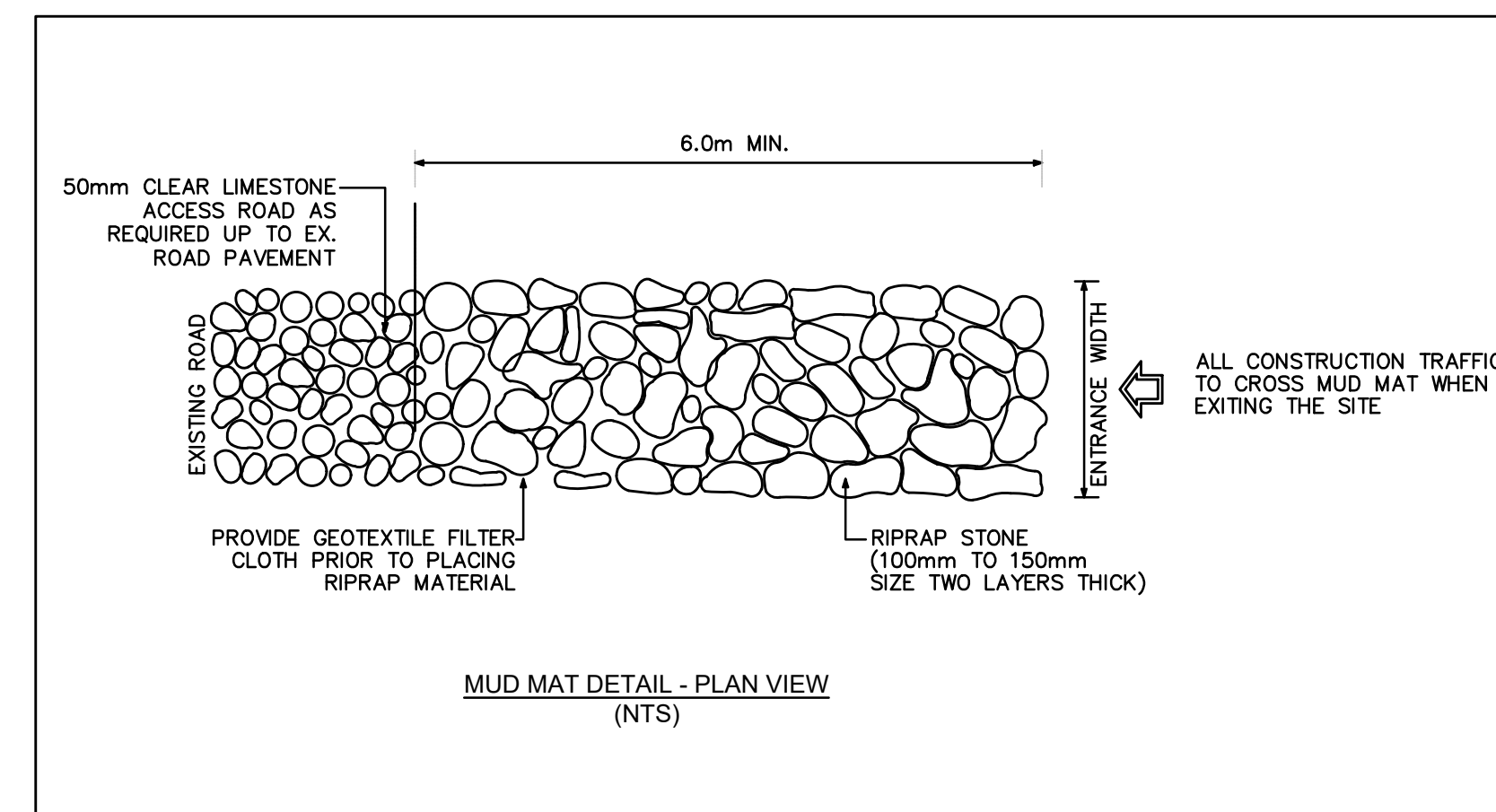

5 MUD MAT DETAIL
SCALE: NTS

Recommended Pavement Structure			
Location	Asphalt Thickness	Base Thickness OPSS Granular A (mm)	Subbase Thickness Granular B Type II (mm)
Full Depth Asphalt	40mm SP12.5 mm 50mm SP SP19.0mm	150	450

REVISION	DATE	DESCRIPTION	BY
0	2024-09-24	ISSUED FOR SITE PLAN CONTROL	ST

SEAL:

DESIGNED BY: M. ST. MARSEILLE
DRAWN BY: G. HOOGWERF
CHECKED BY: S. TAYLOR

DATE: SEPTEMBER 2024

DISCIPLINE: CIVIL

DISCLAIMER: THIS DRAWING AND DESIGN IS COPYRIGHT PROTECTED WHICH SHALL NOT BE USED, REPRODUCED OR REVISED WITHOUT WRITTEN PERMISSION BY WSP. THE CONTRACTOR SHALL CHECK AND VERIFY ALL DIMENSIONS AND UTILITY LOCATIONS AND REPORT ALL ERRORS AND OMISSIONS PRIOR TO COMMENCING WORK.

wsp

WSP CANADA INC.
1224 GARDINERS ROAD, SUITE 201
KINGSTON, ONTARIO
CANADA K7P 0G2
PHONE: 613-634-7373
WWW.WSP.COM

CLIENT: **HOMESTEAD**

PROJECT NUMBER: 221-08957-00

CLIENT REF. #:

TITLE: **GENERAL NOTES AND DETAILS**

PROJECT: **210 CLEARVIEW AVENUE**

DRAWING NUMBER: **C01**

REV: **0**

C:\Users\jhooper\OneDrive\Desktop\240824\210 Clearview Avenue\Drawings\01_C01.dwg
 FILE: m:\020221-08957-00 - 210 Clearview Avenue\Drawings\01_C01.dwg
 PLOTTED: 2024-09-24 8:52 AM
 C:\Users\jhooper\OneDrive\Desktop\240824\210 Clearview Avenue\Drawings\01_C01.dwg
 FILE: m:\020221-08957-00 - 210 Clearview Avenue\Drawings\01_C01.dwg
 PLOTTED: 2024-09-24 8:52 AM

C:\Users\jhooper\OneDrive\Desktop\240824\210 Clearview Avenue\Drawings\01_C01.dwg
 FILE: m:\020221-08957-00 - 210 Clearview Avenue\Drawings\01_C01.dwg
 PLOTTED: 2024-09-24 8:52 AM

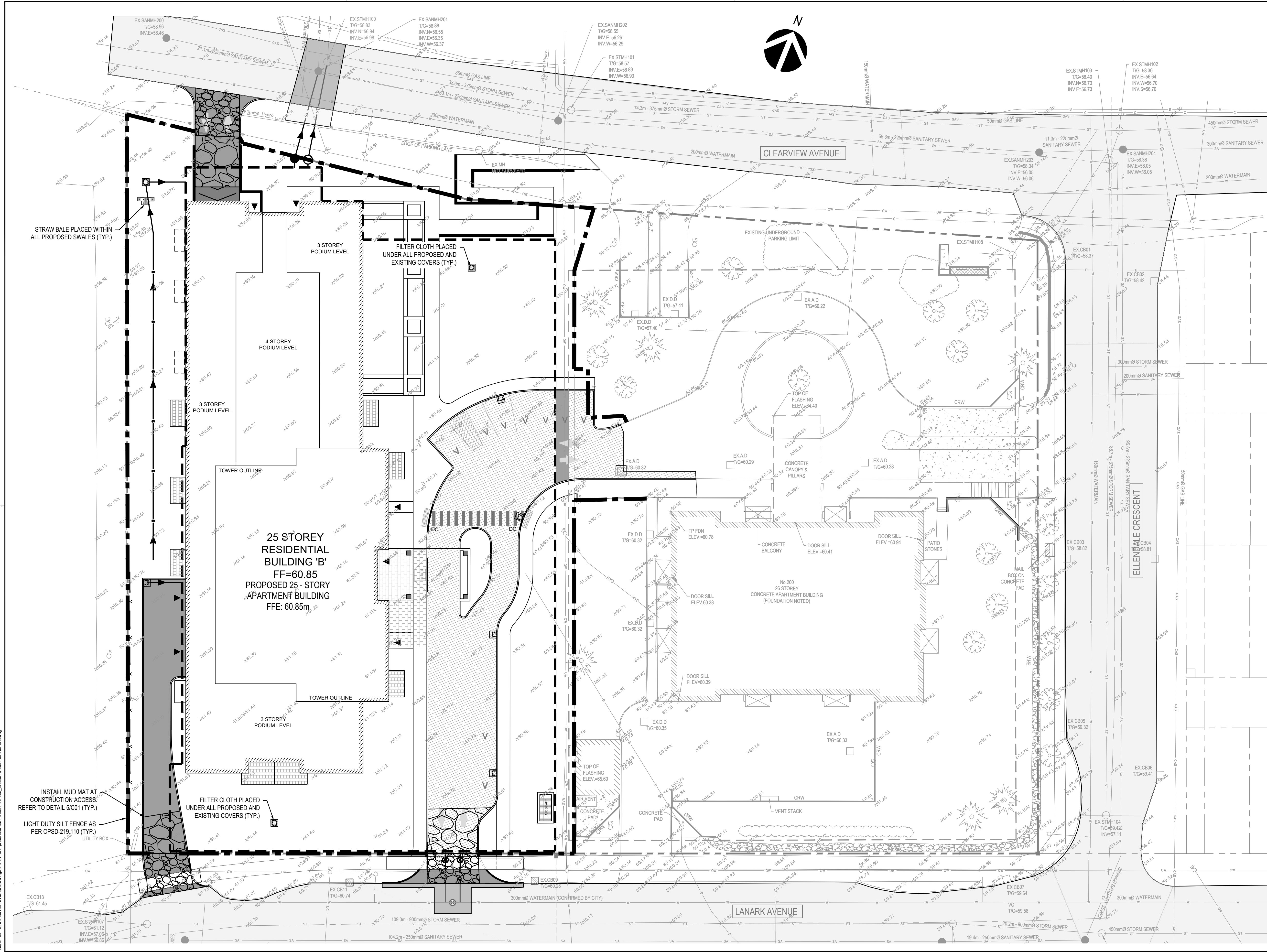

EXISTING LEGEND:		PROPOSED LEGEND:	
	EDGE OF PAVEMENT		EDGE OF PAVEMENT
	CURB		CONCRETE BARRIER CURB (SC.1)
	MAJOR CONTOURS		WATER SERVICE
	MINOR CONTOURS		STORM SEWER
	OVERHEAD WIRE		SANITARY SEWER
	GUY ANCHOR		SWALE
	WATERMAIN		PROPOSED WOOD FENCE
	STORM SEWER		DECK DRAIN
	SANITARY SEWER		STORM CATCH BASIN
	GAS		STORM MAINTENANCE HOLE
	UNDERGROUND		CATCH BASIN MAINTENANCE HOLE
	SWALE		SANITARY MAINTENANCE HOLE
	FENCE		WATERMAIN VALVE
	PROPERTY BOUNDARY		BUILDING ENTRANCE
	SITE TEMPORARY BENCH MARK		SIGN
	FIRE HYDRANT		GRADE ELEVATION
	STORM MANHOLE		FULL DEPTH ASPHALT
	CATCH BASIN		PARTIAL DEPTH ASPHALT
	SANITARY MANHOLE		PAVED SURFACE ROOF
	WATERMAIN VALVE		PAVED SURFACE ROOF REFER TO ARCHITECTURAL
	UTILITY POLE		CONCRETE SIDEWALK (SC2 OR SC4, AS APPLICABLE)
	LIGHT STANDARD		BUILDING
	ROAD SIGN		SURFACE HIGH POINT OVER PARKING GARAGE
	TRANSFORMER		UNDERGROUND PARKING GARAGE
	CULVERT		
	ASPHALT		
	SIDEWALK		
	BUILDING		

ESC LEGEND:	
	LIGHT DUTY SILT FENCE (OPSD 219.110)
	FILTER CLOTH PROTECTION
	MUD MAT
	STRAW BALE FLOW CHECK DAM (OPSD 219.180)

- REFERENCE(S)**
- TOPOGRAPHIC SURVEY BY FARLEY, SMITH & DENIS SURVEYING LTD. FILE NO. 669-21. FEBRUARY 8, 2022.
 - ARCHITECTURAL SITE PLAN BY RODERICK LAHEY ARCHITECT INC. PROJECT NO. 2117. JULY 04, 2024.
 - GEOOTTAWA WEBMAP BY <https://maps.ottawa.ca/geottawa/>, JULY 30, 2024

NOTE(S)

- THIS PLAN IS TO BE READ IN CONJUNCTION WITH THE OTHER DRAWINGS IN THIS PLAN SET.

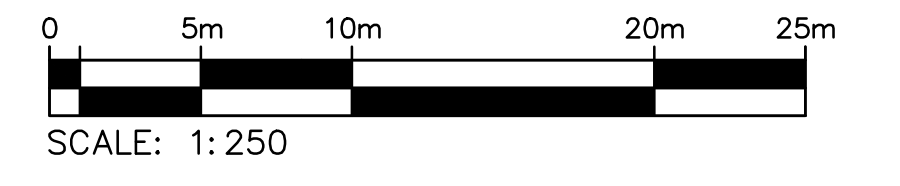

REVISION	DATE	DESCRIPTION	BY
0	2024-09-24	ISSUED FOR SITE PLAN CONTROL	ST

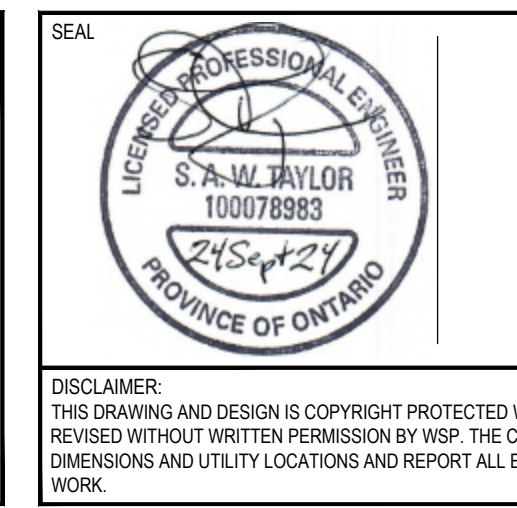

ORIGINAL SCALE: 1:250 DESIGNED BY: M. ST. MARSELLE DRAWN BY: G. HOOGWERF CHECKED BY: S. TAYLOR	DATE: SEPTEMBER 2024 IF THIS BAR IS NOT 25mm LONG, ADJUST YOUR PLOTTING SCALE
DISCIPLINE: CIVIL	DISCLAIMER: THIS DRAWING AND DESIGN IS COPYRIGHT PROTECTED WHICH SHALL NOT BE USED, REPRODUCED OR REVISED WITHOUT WRITTEN PERMISSION BY WSP. THE CONTRACTOR SHALL CHECK AND VERIFY ALL DIMENSIONS AND UTILITY LOCATIONS AND REPORT ALL ERRORS AND OMISSIONS PRIOR TO COMMENCING WORK.

WSP CANADA INC.
 1224 GARDINERS ROAD, SUITE 201
 KINGSTON, ONTARIO
 CANADA K7P 0G2
 PHONE: 613-634-7373
 WWW.WSP.COM

CLIENT:

HOMESTEAD
 CLIENT REF. #

TITLE:
**EROSION AND
 SEDIMENT CONTROL
 PLAN**

PROJECT:
210 CLEARVIEW AVENUE
 DRAWING NUMBER:
C02
 REV. **0**

FILE: m:\2022\221-10857-00-210 clearview avenue\drawing\01_civil\production\22-10857-00-c02_erosion & sediment control.dwg
 PLOTTED: 2024-09-24 8:57 AM
 C:\wsp\kroton\245472

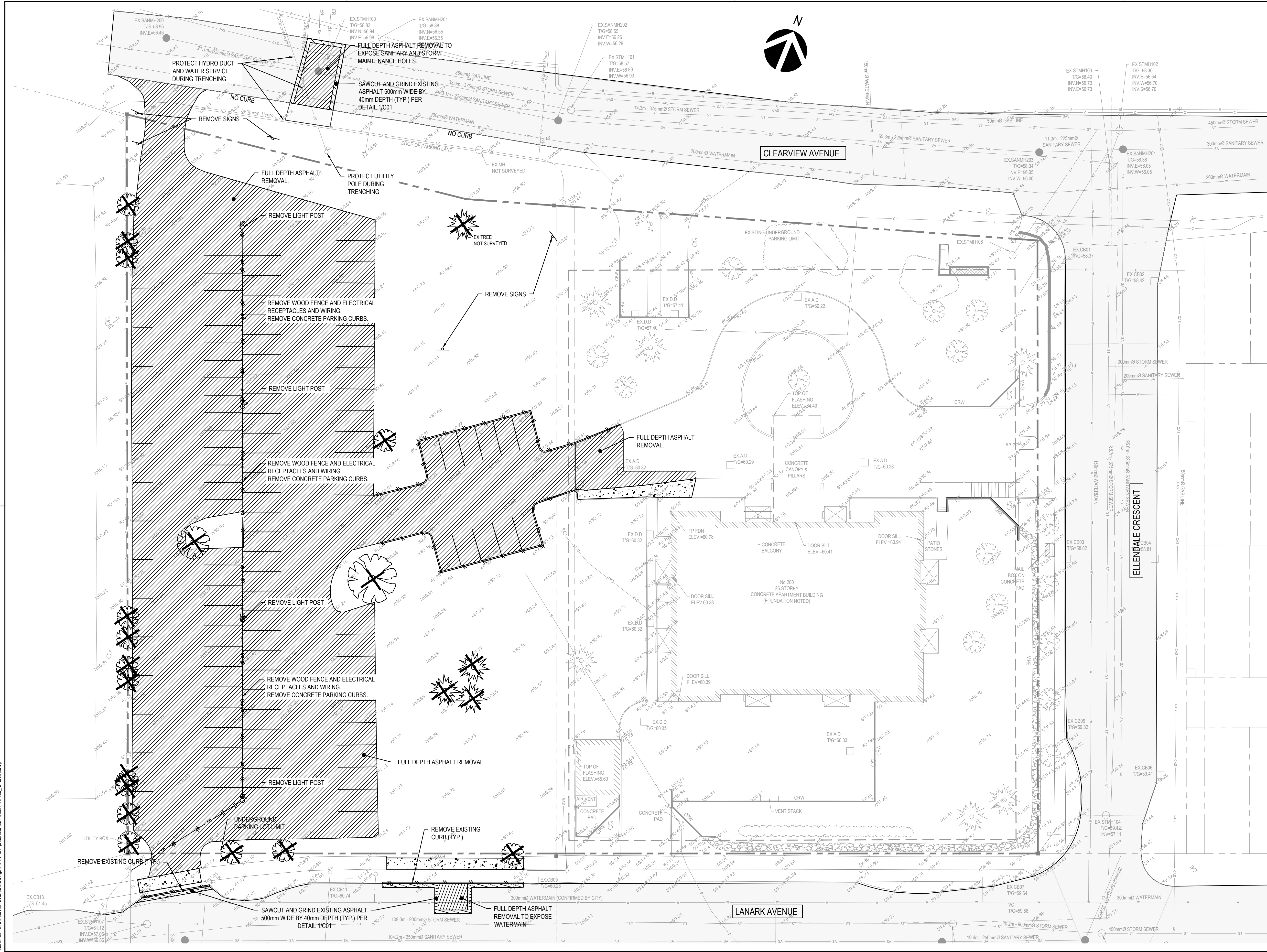

EXISTING LEGEND:

- EDGE OF PAVEMENT
- CURB
- - - BOTTOM OF SLOPE
- - - TOP OF SLOPE
- 99.00 MAJOR CONTOURS
- 0W MINOR CONTOURS
- OVERHEAD WIRE
- GUY ANCHOR
- WATERMAIN
- ST STORM SEWER
- SA SANITARY SEWER
- GAS
- UG UNDERGROUND
- C CABLE
- SWALE
- FENCE
- PROPERTY BOUNDARY
- ⊕ TBM# SITE TEMPORARY BENCH MARK
- TP # TEST PIT LOCATION
- UP UTILITY POLE
- ⊙ SL STREET LIGHT
- ⊙ RS ROAD SIGN
- ⊕ TRANSFORMER
- CULVERT
- ASPHALT
- SIDEWALK
- BUILDING

REMOVAL LEGEND:

- CURB REMOVAL
- UNDERGROUND UTILITY REMOVAL
- ⊗ VEGETATION REMOVAL
- FULL DEPTH ASPHALT REMOVAL
- PARTIAL DEPTH ASPHALT REMOVAL
- CONCRETE SIDEWALK REMOVAL

REFERENCE(S)

1. TOPOGRAPHIC SURVEY BY FARLEY, SMITH & DENIS SURVEYING LTD. FILE NO. 669-21. FEBRUARY 8, 2022.
2. ARCHITECTURAL SITE PLAN BY RODERICK LAHEY ARCHITECT INC. PROJECT NO. 2117. JULY 04, 2024.
3. GEOTOWNA WEBMAP BY <https://maps.ottawa.ca/geotowna/>, JULY 30, 2024

NOTE(S)

1. THIS PLAN IS TO BE READ IN CONJUNCTION WITH THE OTHER DRAWINGS IN THIS PLAN SET.

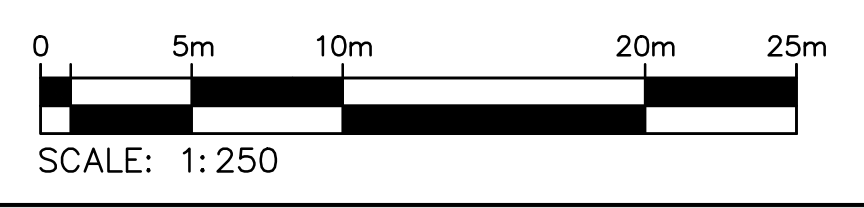

REVISION	DATE	DESCRIPTION	BY
0	2024-09-24	ISSUED FOR SITE PLAN CONTROL	ST



DISCLAIMER: THIS DRAWING AND DESIGN IS COPYRIGHT PROTECTED WHICH SHALL NOT BE USED, REPRODUCED OR REVISED WITHOUT WRITTEN PERMISSION BY WSP. THE CONTRACTOR SHALL CHECK AND VERIFY ALL DIMENSIONS AND UTILITY LOCATIONS AND REPORT ALL ERRORS AND OMISSIONS PRIOR TO COMMENCING WORK.

ORIGINAL SCALE: 1:250
 DESIGNED BY: M. ST. MARSELLE
 DRAWN BY: G. HOOGWERF
 CHECKED BY: S. TAYLOR
 DATE: SEPTEMBER 2024
 IF THIS BAR IS NOT 25mm LONG, ADJUST YOUR PLOTTING SCALE.
 25mm
 DISCIPLINE: CIVIL

wsp
 WSP CANADA INC.
 1224 GARDINERS ROAD, SUITE 201
 KINGSTON, ONTARIO
 CANADA K7P 0G2
 PHONE: 613-634-7373
 WWW.WSP.COM

CLIENT: **HOMESTEAD**
 CLIENT REF. #

TITLE: **REMOVALS PLAN**

PROJECT: **210 CLEARVIEW AVENUE**
 DRAWING NUMBER: **C03**
 REV. **0**

C:\Users\kjohnson\OneDrive\Desktop\240924\210 Clearview Avenue\Drawings\01_C03_1\production\240924_03_C03_removals.dwg
 PLOTTED: 2024-09-24 9:58 AM
 C:\Users\kjohnson\OneDrive\Desktop\240924\210 Clearview Avenue\Drawings\01_C03_1\production\240924_03_C03_removals.dwg

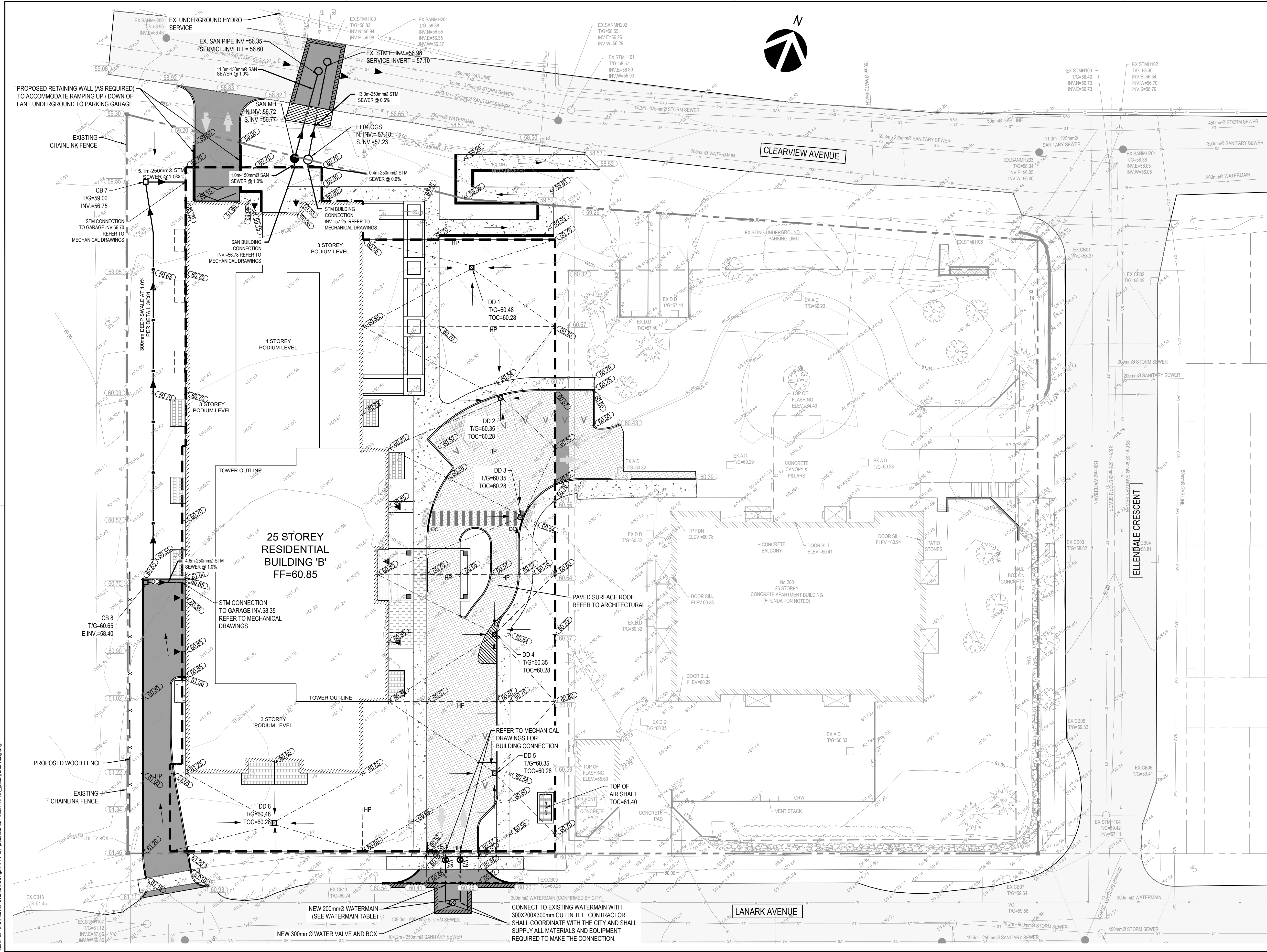

EXISTING LEGEND:

- EDGE OF PAVEMENT
- CURB
- MAJOR CONTOURS
- MINOR CONTOURS
- OVERHEAD WIRE
- GUY ANCHOR
- WATERMAIN
- STORM SEWER
- SANITARY SEWER
- GAS
- UNDERGROUND
- SWALE
- FENCE
- PROPERTY BOUNDARY
- TBM#
- FIRE HYDRANT
- STORM MAINTENANCE HOLE
- CATCH BASIN
- SANITARY MAINTENANCE HOLE
- WATERMAIN VALVE
- UTILITY POLE
- LIGHT STANDARD
- ROAD SIGN
- TRANSFORMER
- EXISTING ELEVATION
- CULVERT
- ASPHALT
- SIDEWALK
- BUILDING

PROPOSED LEGEND:

- EDGE OF PAVEMENT
- CONCRETE BARRIER CURB (SC1.1)
- WATER SERVICE
- ST
- SA
- S
- X
- DECK DRAIN
- STORM CATCH BASIN
- STORM MAINTENANCE HOLE
- CATCH BASIN MAINTENANCE HOLE
- SANITARY MAINTENANCE HOLE
- WATERMAIN VALVE
- BUILDING ENTRANCE
- SIGN
- GRADE ELEVATION
- FULL DEPTH ASPHALT
- PARTIAL DEPTH ASPHALT
- PAVED SURFACE ROOF. REFER TO ARCHITECTURAL
- CONCRETE SIDEWALK (SC2 OR SC4, AS APPLICABLE)
- BUILDING
- HP
- UNDERGROUND PARKING GARAGE
- FLOW DIRECTION ARROW

- REFERENCE(S)**
- TOPOGRAPHIC SURVEY BY FARLEY, SMITH & DENIS SURVEYING LTD. FILE NO. 669-21. FEBRUARY 8, 2022.
 - ARCHITECTURAL SITE PLAN BY RODERICK LAHEY ARCHITECT INC. PROJECT NO. 2117. JULY 04, 2024.
 - GEOOTTAWA WEBMAP BY <https://maps.ottawa.ca/geoottawa/>, JULY 30, 2024

- NOTE(S)**
- THIS PLAN IS TO BE READ IN CONJUNCTION WITH THE OTHER DRAWINGS IN THIS PLAN SET.

WATERMAIN TABLE

STATION	DESCRIPTION	FINISHED GRADE	TOP OF WATERMAIN	COVER
200mm WATERMAIN SERVICE FROM LANARK AVE TO SITE				
W1				
0+000	Connect to Existing	60.35	57.95	2.4
0+005.8	200mm Valve & Box	60.52	58.12	2.4
0+007	Connect to Building	60.57	58.17	2.4
W2				
0+000	Connect to Existing	60.40	58.00	2.4
0+005.8	200mm Valve & Box	60.52	58.12	2.4
0+007	Connect to Building	60.57	58.17	2.4

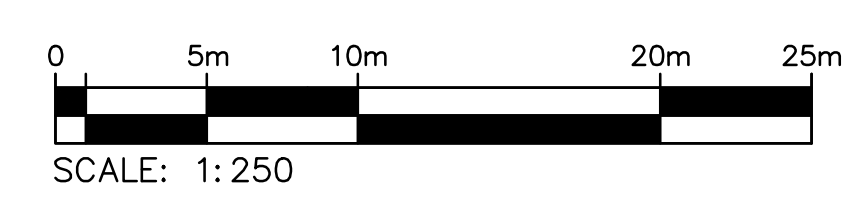

REVISION

REV	DATE	DESCRIPTION	BY
0	2024-09-24	ISSUED FOR SITE PLAN CONTROL	ST



SEAL

DISCLAIMER: THIS DRAWING AND DESIGN IS COPYRIGHT PROTECTED WHICH SHALL NOT BE USED, REPRODUCED OR REVISED WITHOUT WRITTEN PERMISSION BY WSP. THE CONTRACTOR SHALL CHECK AND VERIFY ALL DIMENSIONS AND UTILITY LOCATIONS AND REPORT ALL ERRORS AND OMISSIONS PRIOR TO COMMENCING WORK.

ORIGINAL SCALE: 1:250

DESIGNED BY: M. ST. MARSEILLE

DRAWN BY: G. HOOGWERF

CHECKED BY: S. TAYLOR

DATE: SEPTEMBER 2024

IF THIS BAR IS NOT 25mm LONG, ADJUST YOUR PLOTTING SCALE

25mm

DISCIPLINE: CIVIL

wsp

WSP CANADA INC.
1224 GARDINERS ROAD, SUITE 201
KINGSTON, ONTARIO
CANADA K7P 0G2
PHONE: 613-634-7373
WWW.WSP.COM

HOMESTEAD

CLIENT:

CLIENT REF. #:

TITLE: GRADING AND SERVICING PLAN

PROJECT: 210 CLEARVIEW AVENUE

DRAWING NUMBER: C04

REV.: 0

C:\wsp\proj\2024\2024-09-24-1511\210_clearview_avenue\dwg\01_civil_1_production\2024-09-24_1511.dwg
 PLOTTED: 2024-09-24 1:51 PM
 C:\wsp\proj\2024\2024-09-24-1511\210_clearview_avenue\dwg\01_civil_1_production\2024-09-24_1511.dwg

APPENDIX

B

CITY COMMUNICATION, PRE-CONSULTATION DOCUMENTS & CITY SERVICING CHECKLIST

Ottenhof, Maggie

From: Fawzi, Mohammed <mohammed.fawzi@ottawa.ca>
Sent: September 2, 2022 12:00 PM
To: Ottenhof, Maggie
Cc: Nicholas Higginson; Davidson, Steve
Subject: RE: 210 Clearview Avenue ZBLA - Request for Water Boundary Conditions and Sanitary Capacity

Hi Maggie,

This is to confirm there are no constraints regarding sanitary flow.

Thank you and have a great weekend.

Best Regards,

Mohammed Fawzi, P.Eng.

Project Manager
Planning, Infrastructure and Economic Development Department - Services de la planification, de l'infrastructure et du développement économique
Development Review - Central Branch
City of Ottawa | Ville d'Ottawa
110 Laurier Avenue West Ottawa, ON | 110, avenue. Laurier Ouest. Ottawa (Ontario) K1P 1J1
613.580.2424 ext./poste 20120, Mohammed.Fawzi@ottawa.ca

****Please note that due to the current situation, I am working remotely. Email is currently the best way to contact me****

From: Fawzi, Mohammed
Sent: August 29, 2022 11:24 AM
To: Ottenhof, Maggie <Maggie.Ottenhof@wsp.com>
Cc: Nicholas Higginson <NHigginson@homestead.ca>; Davidson, Steve <Steve.P.Davidson@wsp.com>
Subject: RE: 210 Clearview Avenue ZBLA - Request for Water Boundary Conditions and Sanitary Capacity

Hi Maggie,

This is to confirm that your request for boundary conditions has been received. I am also looking into the matter regarding sanitary sewer capacity constraints.

In regards to the required plans/reports. A SWM report is not required for the ZBLA submission. As mentioned below, however, the Adequacy of Servicing Report must include a section that speaks to storm water management such as existing conditions, quantity and quality controls, etc.

Happy to discuss further if needed. Thank you.

Best Regards,

Mohammed Fawzi, P.Eng.

Project Manager

Planning, Infrastructure and Economic Development Department - Services de la planification, de l'infrastructure et du développement économique

Development Review - Central Branch

City of Ottawa | Ville d'Ottawa

110 Laurier Avenue West Ottawa, ON | 110, avenue. Laurier Ouest. Ottawa (Ontario) K1P 1J1

613.580.2424 ext./poste 20120, Mohammed.Fawzi@ottawa.ca

****Please note that due to the current situation, I am working remotely. Email is currently the best way to contact me****

From: Ottenhof, Maggie <Maggie.Ottenhof@wsp.com>

Sent: August 25, 2022 5:00 PM

To: Fawzi, Mohammed <mohammed.fawzi@ottawa.ca>

Cc: Nicholas Higginson <NHigginson@homestead.ca>; Davidson, Steve <Steve.P.Davidson@wsp.com>

Subject: 210 Clearview Avenue ZBLA - Request for Water Boundary Conditions and Sanitary Capacity

CAUTION: This email originated from an External Sender. Please do not click links or open attachments unless you recognize the source.

ATTENTION : Ce courriel provient d'un expéditeur externe. Ne cliquez sur aucun lien et n'ouvrez pas de pièce jointe, excepté si vous connaissez l'expéditeur.

Good afternoon,

We are currently preparing an Adequacy of Services Report to support a rezoning application for 200 Clearview Avenue in Ottawa. We have received initial pre-consultation notes from the City and would therefore like to request water boundary conditions. Additionally, we would like to confirm if there is sufficient capacity in the existing 250 mm diameter sanitary sewer on Lanark Avenue and/or sufficient capacity in the 225 mm diameter sanitary sewer along Clearview Avenue. Based on the conceptual design, the demands are as follows:

Water Supply:

Average Day Demand: 1.25 L/s

Maximum Daily Demand: 3.10 L/s

Maximum Hourly Demand: 6.75 L/s

Fire Flow: 83.3 L/s (FUS calculation attached)

Max Day + Fire Flow: 86.4 L/s

Sanitary Demand:

Average Day: 1.25 L/s

Peak: 4.45 L/s

In addition to the requested information above, can you please confirm that an Adequacy of Services Report is sufficient for the ZBLA submission (i.e., a SWM report will not be required for ZBLA)? Our report will include a section on stormwater management quantity and quality control and we will submit a detailed SWM report at the SPCA stage.

Let me know if you need anything further from us or have any questions.

Thank you,
Maggie



Maggie Ottenhof

Municipal Engineer
P.Eng.
She/Her

T+ 1 613-856-0329

WSP Canada Inc.
1224 Gardiners Road, Suite 201
Kingston, Ontario
K7P 0G2 Canada

wsp.com

NOTICE: This communication and any attachments ("this message") may contain information which is privileged, confidential, proprietary or otherwise subject to restricted disclosure under applicable law. This message is for the sole use of the intended recipient(s). Any unauthorized use, disclosure, viewing, copying, alteration, dissemination or distribution of, or reliance on, this message is strictly prohibited. If you have received this message in error, or you are not an authorized or intended recipient, please notify the sender immediately by replying to this message, delete this message and all copies from your e-mail system and destroy any printed copies. You are receiving this communication because you are listed as a current WSP contact. Should you have any questions regarding WSP's electronic communications policy, please consult our Anti-Spam Commitment at www.wsp.com/cas. For any concern or if you believe you should not be receiving this message, please forward this message to cascompliance@wsp.com so that we can promptly address your request. Note that not all messages sent by WSP qualify as commercial electronic messages.

AVIS : Ce message, incluant tout fichier l'accompagnant (« le message »), peut contenir des renseignements ou de l'information privilégiés, confidentiels, propriétaires ou à divulgation restreinte en vertu de la loi. Ce message est destiné à l'usage exclusif du/des destinataire(s) voulu(s). Toute utilisation non permise, divulgation, lecture, reproduction, modification, diffusion ou distribution est interdite. Si vous avez reçu ce message par erreur, ou que vous n'êtes pas un destinataire autorisé ou voulu, veuillez en aviser l'expéditeur immédiatement et détruire le message et toute copie électronique ou imprimée. Vous recevez cette communication car vous faites partie des contacts de WSP. Si vous avez des questions concernant la politique de communications électroniques de WSP, veuillez consulter notre Engagement anti-pourriel au www.wsp.com/lcap. Pour toute question ou si vous croyez que vous ne devriez pas recevoir ce message, prière de le transférer au conformitelcap@wsp.com afin que nous puissions rapidement traiter votre demande. Notez que ce ne sont pas tous les messages transmis par WSP qui constituent des messages électroniques commerciaux.

-LAEmhHhZdJzBITWfa4Hgs7pbKl

This e-mail originates from the City of Ottawa e-mail system. Any distribution, use or copying of this e-mail or the information it contains by other than the intended recipient(s) is unauthorized. Thank you.

Le présent courriel a été expédié par le système de courriels de la Ville d'Ottawa. Toute distribution, utilisation ou reproduction du courriel ou des renseignements qui s'y trouvent par une personne autre que son destinataire prévu est interdite. Je vous remercie de votre collaboration.

Ottenhof, Maggie

From: Fawzi, Mohammed <mohammed.fawzi@ottawa.ca>
Sent: September 22, 2022 11:01 AM
To: Ottenhof, Maggie
Cc: Nicholas Higginson; Davidson, Steve
Subject: RE: 210 Clearview Avenue ZBLA - Request for Water Boundary Conditions and Sanitary Capacity
Attachments: 210 Clearview Avenue September 2022.pdf

Hi Maggie,

The following are boundary conditions, HGL, for hydraulic analysis at 210 Clearview Avenue (zone 1W) assumed to be a dual connection to the 305 mm watermain on Lanark Avenue (see attached PDF for location).

Minimum HGL: 108.6 m

Maximum HGL: 115.1 m

Max Day + Fire Flow (83.3 L/s): 109.9 m

These are for current conditions and are based on computer model simulation.

Disclaimer: The boundary condition information is based on current operation of the city water distribution system. The computer model simulation is based on the best information available at the time. The operation of the water distribution system can change on a regular basis, resulting in a variation in boundary conditions. The physical properties of watermains deteriorate over time, as such must be assumed in the absence of actual field test data. The variation in physical watermain properties can therefore alter the results of the computer model simulation.

Best Regards,

Mohammed Fawzi, P.Eng.

Project Manager

Planning, Infrastructure and Economic Development Department - Services de la planification, de l'infrastructure et du développement économique

Development Review - Central Branch

City of Ottawa | Ville d'Ottawa

110 Laurier Avenue West Ottawa, ON | 110, avenue. Laurier Ouest. Ottawa (Ontario) K1P 1J1

613.580.2424 ext./poste 20120, Mohammed.Fawzi@ottawa.ca

****Please note that due to the current situation, I am working remotely. Email is currently the best way to contact me****

From: Ottenhof, Maggie <Maggie.Ottenhof@wsp.com>

Sent: September 19, 2022 9:28 AM

To: Fawzi, Mohammed <mohammed.fawzi@ottawa.ca>
Cc: Nicholas Higginson <NHigginson@homestead.ca>; Davidson, Steve <Steve.P.Davidson@wsp.com>
Subject: RE: 210 Clearview Avenue ZBLA - Request for Water Boundary Conditions and Sanitary Capacity

CAUTION: This email originated from an External Sender. Please do not click links or open attachments unless you recognize the source.

ATTENTION : Ce courriel provient d'un expéditeur externe. Ne cliquez sur aucun lien et n'ouvrez pas de pièce jointe, excepté si vous connaissez l'expéditeur.

Hi Mohammed,

Are there any updates regarding the boundary conditions request for Lanark Avenue?

Thanks,
Maggie



Maggie Ottenhof

Municipal Engineer
P.Eng.
She/Her

T+ 1 613-856-0329

WSP Canada Inc.
1224 Gardiners Road, Suite 201
Kingston, Ontario
K7P 0G2 Canada

wsp.com

From: Ottenhof, Maggie
Sent: September 12, 2022 12:00 PM
To: Fawzi, Mohammed <mohammed.fawzi@ottawa.ca>
Cc: Nicholas Higginson <NHigginson@homestead.ca>; Davidson, Steve <Steve.P.Davidson@wsp.com>
Subject: RE: 210 Clearview Avenue ZBLA - Request for Water Boundary Conditions and Sanitary Capacity

Hi Mohammed,

Thank you for confirming. I've attached a revised connection location figure (dual feed from Lanark Avenue).

Thanks,
Maggie



Maggie Ottenhof

Municipal Engineer
P.Eng.
She/Her

T+ 1 613-856-0329

WSP Canada Inc.
1224 Gardiners Road, Suite 201

Kingston, Ontario
K7P 0G2 Canada

wsp.com

From: Fawzi, Mohammed <mohammed.fawzi@ottawa.ca>
Sent: September 12, 2022 10:25 AM
To: Ottenhof, Maggie <Maggie.Ottenhof@wsp.com>
Cc: Nicholas Higginson <NHigginson@homestead.ca>; Davidson, Steve <Steve.P.Davidson@wsp.com>
Subject: RE: 210 Clearview Avenue ZBLA - Request for Water Boundary Conditions and Sanitary Capacity

Hi Maggie,

After further review, the 203mm watermain on Clearview is a dead-end main. The site requires two feeds and **both cant be from Clearview i.e. a dead-end.**

Please provide a revised connection location figure, whether it be a dual feed from Lanark or 1st connection from Clearview and the 2nd from Lanark.

Thank you.

Best Regards,

Mohammed Fawzi, P.Eng.

Project Manager
Planning, Infrastructure and Economic Development Department - Services de la planification, de l'infrastructure et du développement économique
Development Review - Central Branch
City of Ottawa | Ville d'Ottawa
110 Laurier Avenue West Ottawa, ON | 110, avenue. Laurier Ouest. Ottawa (Ontario) K1P 1J1
613.580.2424 ext./poste 20120, Mohammed.Fawzi@ottawa.ca

****Please note that due to the current situation, I am working remotely. Email is currently the best way to contact me****

From: Ottenhof, Maggie <Maggie.Ottenhof@wsp.com>
Sent: September 09, 2022 10:47 AM
To: Fawzi, Mohammed <mohammed.fawzi@ottawa.ca>
Cc: Nicholas Higginson <NHigginson@homestead.ca>; Davidson, Steve <Steve.P.Davidson@wsp.com>
Subject: RE: 210 Clearview Avenue ZBLA - Request for Water Boundary Conditions and Sanitary Capacity

CAUTION: This email originated from an External Sender. Please do not click links or open attachments unless you recognize the source.

ATTENTION : Ce courriel provient d'un expéditeur externe. Ne cliquez sur aucun lien et n'ouvrez pas de pièce jointe, excepté si vous connaissez l'expéditeur.

Hi Mohammed,

Are there any updates regarding the boundary conditions request?

Thanks,
Maggie



Maggie Ottenhof

Municipal Engineer
P.Eng.
She/Her

T+ 1 613-856-0329

WSP Canada Inc.
1224 Gardiners Road, Suite 201
Kingston, Ontario
K7P 0G2 Canada

wsp.com

From: Fawzi, Mohammed <mohammed.fawzi@ottawa.ca>

Sent: August 29, 2022 11:24 AM

To: Ottenhof, Maggie <Maggie.Ottenhof@wsp.com>

Cc: Nicholas Higginson <NHigginson@homestead.ca>; Davidson, Steve <Steve.P.Davidson@wsp.com>

Subject: RE: 210 Clearview Avenue ZBLA - Request for Water Boundary Conditions and Sanitary Capacity

Hi Maggie,

This is to confirm that your request for boundary conditions has been received. I am also looking into the matter regarding sanitary sewer capacity constraints.

In regards to the required plans/reports. A SWM report is not required for the ZBLA submission. As mentioned below, however, the Adequacy of Servicing Report must include a section that speaks to storm water management such as existing conditions, quantity and quality controls, etc.

Happy to discuss further if needed. Thank you.

Best Regards,

Mohammed Fawzi, P.Eng.

Project Manager

Planning, Infrastructure and Economic Development Department - Services de la planification, de l'infrastructure et du développement économique

Development Review - Central Branch

City of Ottawa | Ville d'Ottawa

110 Laurier Avenue West Ottawa, ON | 110, avenue. Laurier Ouest. Ottawa (Ontario) K1P 1J1

613.580.2424 ext./poste 20120, Mohammed.Fawzi@ottawa.ca

****Please note that due to the current situation, I am working remotely. Email is currently the best way to contact me****

From: Ottenhof, Maggie <Maggie.Ottenhof@wsp.com>

Sent: August 25, 2022 5:00 PM

To: Fawzi, Mohammed <mohammed.fawzi@ottawa.ca>

Cc: Nicholas Higginson <NHigginson@homestead.ca>; Davidson, Steve <Steve.P.Davidson@wsp.com>

Subject: 210 Clearview Avenue ZBLA - Request for Water Boundary Conditions and Sanitary Capacity

CAUTION: This email originated from an External Sender. Please do not click links or open attachments unless you recognize the source.

ATTENTION : Ce courriel provient d'un expéditeur externe. Ne cliquez sur aucun lien et n'ouvrez pas de pièce jointe, excepté si vous connaissez l'expéditeur.

Good afternoon,

We are currently preparing an Adequacy of Services Report to support a rezoning application for 200 Clearview Avenue in Ottawa. We have received initial pre-consultation notes from the City and would therefore like to request water boundary conditions. Additionally, we would like to confirm if there is sufficient capacity in the existing 250 mm diameter sanitary sewer on Lanark Avenue and/or sufficient capacity in the 225 mm diameter sanitary sewer along Clearview Avenue. Based on the conceptual design, the demands are as follows:

Water Supply:

Average Day Demand: 1.25 L/s

Maximum Daily Demand: 3.10 L/s

Maximum Hourly Demand: 6.75 L/s

Fire Flow: 83.3 L/s (FUS calculation attached)

Max Day + Fire Flow: 86.4 L/s

Sanitary Demand:

Average Day: 1.25 L/s

Peak: 4.45 L/s

In addition to the requested information above, can you please confirm that an Adequacy of Services Report is sufficient for the ZBLA submission (i.e., a SWM report will not be required for ZBLA)? Our report will include a section on stormwater management quantity and quality control and we will submit a detailed SWM report at the SPCA stage.

Let me know if you need anything further from us or have any questions.

Thank you,
Maggie



Maggie Ottenhof

Municipal Engineer

P.Eng.

She/Her

T+ 1 613-856-0329

WSP Canada Inc.

1224 Gardiners Road, Suite 201

Kingston, Ontario
K7P 0G2 Canada

wsp.com

NOTICE: This communication and any attachments ("this message") may contain information which is privileged, confidential, proprietary or otherwise subject to restricted disclosure under applicable law. This message is for the sole use of the intended recipient(s). Any unauthorized use, disclosure, viewing, copying, alteration, dissemination or distribution of, or reliance on, this message is strictly prohibited. If you have received this message in error, or you are not an authorized or intended recipient, please notify the sender immediately by replying to this message, delete this message and all copies from your e-mail system and destroy any printed copies. You are receiving this communication because you are listed as a current WSP contact. Should you have any questions regarding WSP's electronic communications policy, please consult our Anti-Spam Commitment at www.wsp.com/cas. For any concern or if you believe you should not be receiving this message, please forward this message to cascompliance@wsp.com so that we can promptly address your request. Note that not all messages sent by WSP qualify as commercial electronic messages.

AVIS : Ce message, incluant tout fichier l'accompagnant (« le message »), peut contenir des renseignements ou de l'information privilégiés, confidentiels, propriétaires ou à divulgation restreinte en vertu de la loi. Ce message est destiné à l'usage exclusif du/des destinataire(s) voulu(s). Toute utilisation non permise, divulgation, lecture, reproduction, modification, diffusion ou distribution est interdite. Si vous avez reçu ce message par erreur, ou que vous n'êtes pas un destinataire autorisé ou voulu, veuillez en aviser l'expéditeur immédiatement et détruire le message et toute copie électronique ou imprimée. Vous recevez cette communication car vous faites partie des contacts de WSP. Si vous avez des questions concernant la politique de communications électroniques de WSP, veuillez consulter notre Engagement anti-pourriel au www.wsp.com/lcap. Pour toute question ou si vous croyez que vous ne devriez pas recevoir ce message, prière de le transférer au conformitelcap@wsp.com afin que nous puissions rapidement traiter votre demande. Notez que ce ne sont pas tous les messages transmis par WSP qui constituent des messages électroniques commerciaux.

-LAEmHhHzdJzBITWfa4Hgs7pbKl

This e-mail originates from the City of Ottawa e-mail system. Any distribution, use or copying of this e-mail or the information it contains by other than the intended recipient(s) is unauthorized. Thank you.

Le présent courriel a été expédié par le système de courriels de la Ville d'Ottawa. Toute distribution, utilisation ou reproduction du courriel ou des renseignements qui s'y trouvent par une personne autre que son destinataire prévu est interdite. Je vous remercie de votre collaboration.

This e-mail originates from the City of Ottawa e-mail system. Any distribution, use or copying of this e-mail or the information it contains by other than the intended recipient(s) is unauthorized. Thank you.

Le présent courriel a été expédié par le système de courriels de la Ville d'Ottawa. Toute distribution, utilisation ou reproduction du courriel ou des renseignements qui s'y trouvent par une personne autre que son destinataire prévu est interdite. Je vous remercie de votre collaboration.

This e-mail originates from the City of Ottawa e-mail system. Any distribution, use or copying of this e-mail or the information it contains by other than the intended recipient(s) is unauthorized. Thank you.

Le présent courriel a été expédié par le système de courriels de la Ville d'Ottawa. Toute distribution, utilisation ou reproduction du courriel ou des renseignements qui s'y trouvent par une personne autre que son destinataire prévu est interdite. Je vous remercie de votre collaboration.

Boundary Conditions for 210 Clearview Avenue

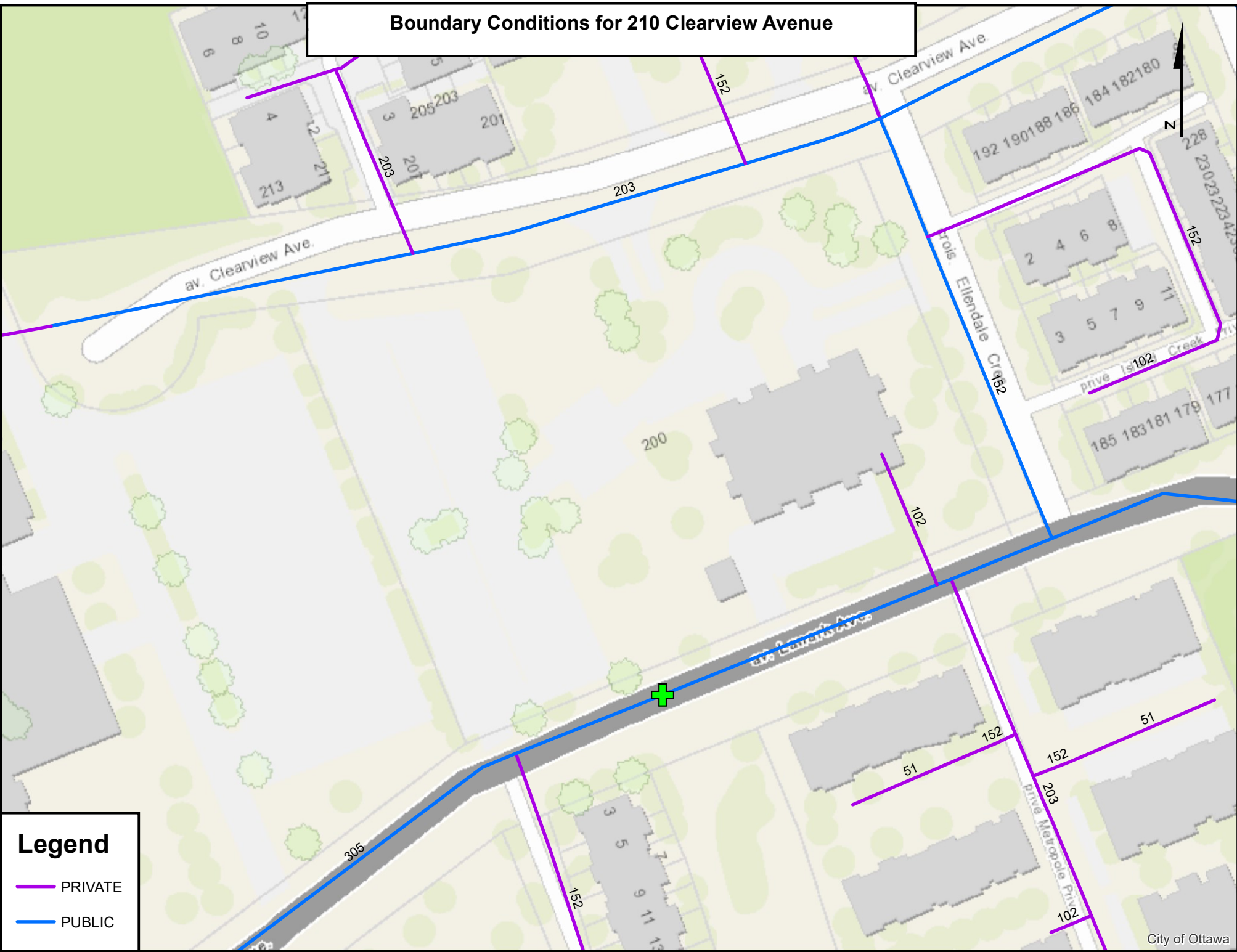

Legend

- PRIVATE
- PUBLIC

Ottenhof, Maggie

From: Eric Lalande <eric.lalande@rvca.ca>
Sent: September 12, 2022 9:35 AM
To: Ottenhof, Maggie
Cc: Nicholas Higginson
Subject: RE: 210 Clearview Avenue, Ottawa - Confirmation of SWM Quality Criteria

Hi Maggie,

I notice your email shows as having an attachment, although none is present when I open the email.

Based on your email it would appear that enhanced water protection would be required. (i.e., Level 1, enhanced protection 80% Total Suspended Solids (TSS) removal). This is the standard within our watershed, I would typically review site plans to determine if these requirements could be waived, however given the proximity to the outlet, I am not sure that would be the case here.

Thanks,

Eric Lalande, MCIP, RPP
Planner, RVCA
613-692-3571 x1137

From: Ottenhof, Maggie <Maggie.Ottenhof@wsp.com>
Sent: Wednesday, September 7, 2022 1:31 PM
To: Eric Lalande <eric.lalande@rvca.ca>
Cc: Nicholas Higginson <NHigginson@homestead.ca>
Subject: RE: 210 Clearview Avenue, Ottawa - Confirmation of SWM Quality Criteria

Hi Eric,

Following up to the email below – are you able to please confirm the level of stormwater quality treatment required for the proposed development at 210 Clearview Avenue?

Thanks,
Maggie



Maggie Ottenhof

Municipal Engineer
P.Eng.
She/Her

T+ 1 613-856-0329

WSP Canada Inc.
1224 Gardiners Road, Suite 201
Kingston, Ontario
K7P 0G2 Canada

wsp.com

From: Ottenhof, Maggie
Sent: August 22, 2022 12:20 PM
To: eric.lalande@rvca.ca
Cc: Davidson, Steve <Steve.P.Davidson@wsp.com>; Nicholas Higginson <NHigginson@homestead.ca>
Subject: 210 Clearview Avenue, Ottawa - Confirmation of SWM Quality Criteria

Hi Eric,

We are currently working on a re-zoning application at 210 Clearview Avenue in Ottawa. The 25-storey building development is proposed in the location of the existing parking lot and a portion of greenspace to the west of the existing building. We've received initial pre-consultation comments from the City which includes a note that the RVCA is to provide quality control criteria.

Can you please confirm the level of stormwater quality treatment as per the Ministry of Environment, Conservation and Parks (MECP) Stormwater Management Planning and Design Manuel (i.e., Level 1, enhanced protection 80% Total Suspended Solids (TSS) removal)?

Thank you,
Maggie



Maggie Ottenhof

Municipal Engineer
P.Eng.
She/Her

T+ 1 613-856-0329

WSP Canada Inc.
1224 Gardiners Road, Suite 201
Kingston, Ontario
K7P 0G2 Canada

wsp.com

NOTICE: This communication and any attachments ("this message") may contain information which is privileged, confidential, proprietary or otherwise subject to restricted disclosure under applicable law. This message is for the sole use of the intended recipient(s). Any unauthorized use, disclosure, viewing, copying, alteration, dissemination or distribution of, or reliance on, this message is strictly prohibited. If you have received this message in error, or you are not an authorized or intended recipient, please notify the sender immediately by replying to this message, delete this message and all copies from your e-mail system and destroy any printed copies. You are receiving this communication because you are listed as a current WSP contact. Should you have any questions regarding WSP's electronic communications policy, please consult our Anti-Spam Commitment at www.wsp.com/cas. For any concern or if you believe you should not be receiving this message, please forward this message to caslcompliance@wsp.com so that we can promptly address your request. Note that not all messages sent by WSP qualify as commercial electronic messages.

AVIS : Ce message, incluant tout fichier l'accompagnant (« le message »), peut contenir des renseignements ou de l'information privilégiés, confidentiels, propriétaires ou à divulgation restreinte en vertu de la loi. Ce message est destiné à l'usage exclusif du/des destinataire(s) voulu(s). Toute utilisation non permise, divulgation, lecture, reproduction, modification, diffusion ou distribution est interdite. Si vous avez reçu ce message par erreur, ou que vous n'êtes pas un destinataire autorisé ou voulu, veuillez en aviser l'expéditeur immédiatement et détruire le message et toute copie électronique ou imprimée. Vous recevez cette communication car vous faites partie des contacts de WSP. Si vous avez des questions concernant la politique de communications électroniques de WSP, veuillez consulter notre Engagement anti-pourriel au www.wsp.com/lcap. Pour toute question ou si vous croyez que vous ne devriez pas recevoir ce message, prière de le transférer au conformitelcap@wsp.com afin que nous puissions rapidement traiter votre demande. Notez que ce ne sont pas tous les messages transmis par WSP qui constituent des messages électroniques commerciaux.

-LAEmHhHzdJzBITWfa4Hgs7pbKl

St. Marseille, Marina

From: Davidson, Steve
Sent: May 31, 2023 16:40
To: Nicholas Higginson
Cc: St. Marseille, Marina; Searle, Daniel
Subject: Re: 200/210 Clearview Avenue - First Resubmission

Good news. Thanks Nick!

SD



Steve Davidson

Senior Manager
Land Development & Municipal Engineering
P.Eng., OLS (Ret.), MBA
(He/Him)

T+ 1 613-634-7373
T+ 1 613-856-0307 (Direct)



WSP Canada Inc.
1224 Gardiners Road, Suite 201
Kingston, ON
K7P 0G2 Canada

wsp.com

VACATION ALERT: June 12 – June 16, 2023

(Returning on June 19th)

From: Nicholas Higginson <NHigginson@homestead.ca>
Sent: May 31, 2023 4:03 PM
To: Davidson, Steve <Steve.P.Davidson@wsp.com>
Subject: FW: 200/210 Clearview Avenue - First Resubmission

Hi Steve,

See below, the City will allow two set of services to our site.



Nicholas Higginson, P.Eng. | Project Manager, Construction

Homestead Land Holdings Limited
80 Johnson Street, Kingston, ON, K7L 1X7
p: 613.532.0492 | f: 613.546.2969

From: Bernier, John <John.Bernier@ottawa.ca>
Sent: Tuesday, May 30, 2023 2:53 PM
To: Patricia Warren <warren@fotenn.com>
Cc: Jack Mangan <JMangan@homestead.ca>; Mark Brule <mbrule@homestead.ca>; Paul Black <black@fotenn.com>
Subject: RE: 200/210 Clearview Avenue - First Resubmission

Hi Patricia,

AMB advises that two sets of services on this particular lot will be permissible.

Regards,

John Bernier, MCIP, RPP

Planner II | Urbaniste II

Development Review, Central | *Examen des projets d'aménagement, Central*

Planning, Real Estate and Economic Development Department | Direction générale de la planification, des biens immobiliers et du développement

City of Ottawa | *Ville d'Ottawa*

110 Laurier Avenue West. Ottawa, ON | *110, avenue. Laurier Ouest. Ottawa (Ontario) K1P 1J1*

613.580.2424 ext./poste 21576

ottawa.ca/planning / ottawa.ca/urbanisme

Please note that during the current public health emergency I am working remotely. Email is the easiest and most reliable way of reaching me at this time. Thank you for your cooperation.

From: Patricia Warren <warren@fotenn.com>
Sent: May 26, 2023 1:30 PM
To: Bernier, John <John.Bernier@ottawa.ca>
Cc: Jack Mangan <JMangan@homestead.ca>; Mark Brule <mbrule@homestead.ca>; Paul Black <black@fotenn.com>
Subject: RE: 200/210 Clearview Avenue - First Resubmission

CAUTION: This email originated from an External Sender. Please do not click links or open attachments unless you recognize the source.

ATTENTION : Ce courriel provient d'un expéditeur externe. Ne cliquez sur aucun lien et n'ouvrez pas de pièce jointe, excepté si vous connaissez l'expéditeur.

Hi John,

Hope you're doing well! Comment 6 under the Adequacy of Services Report comments states that comments would be forwarded as it relates to two sets of services being permitted on the site. Can you confirm if you have received any comments about this?

Thank you!

Patricia Warren, M.Pl.

Planner

T 613.730.5709. ext. 225

St. Marseille, Marina

From: Davidson, Steve
Sent: May 31, 2023 16:40
To: Nicholas Higginson
Cc: St. Marseille, Marina; Searle, Daniel
Subject: Re: 200/210 Clearview Avenue - First Resubmission

Good news. Thanks Nick!

SD



Steve Davidson

Senior Manager
Land Development & Municipal Engineering
P.Eng., OLS (Ret.), MBA
(He/Him)

T+ 1 613-634-7373
T+ 1 613-856-0307 (Direct)



WSP Canada Inc.
1224 Gardiners Road, Suite 201
Kingston, ON
K7P 0G2 Canada

wsp.com

VACATION ALERT: June 12 – June 16, 2023

(Returning on June 19th)

From: Nicholas Higginson <NHigginson@homestead.ca>
Sent: May 31, 2023 4:03 PM
To: Davidson, Steve <Steve.P.Davidson@wsp.com>
Subject: FW: 200/210 Clearview Avenue - First Resubmission

Hi Steve,

See below, the City will allow two set of services to our site.



Nicholas Higginson, P.Eng. | Project Manager, Construction

Homestead Land Holdings Limited

80 Johnson Street, Kingston, ON, K7L 1X7

p: 613.532.0492 | f: 613.546.2969

From: Bernier, John <John.Bernier@ottawa.ca>
Sent: Tuesday, May 30, 2023 2:53 PM
To: Patricia Warren <warren@fotenn.com>
Cc: Jack Mangan <JMangan@homestead.ca>; Mark Brule <mbrule@homestead.ca>; Paul Black <black@fotenn.com>
Subject: RE: 200/210 Clearview Avenue - First Resubmission

Hi Patricia,

AMB advises that two sets of services on this particular lot will be permissible.

Regards,

John Bernier, MCIP, RPP

Planner II | Urbaniste II

Development Review, Central | *Examen des projets d'aménagement, Central*

Planning, Real Estate and Economic Development Department | Direction générale de la planification, des biens immobiliers et du développement

City of Ottawa | *Ville d'Ottawa*

110 Laurier Avenue West. Ottawa, ON | *110, avenue. Laurier Ouest. Ottawa (Ontario) K1P 1J1*

613.580.2424 ext./poste 21576

ottawa.ca/planning / ottawa.ca/urbanisme

Please note that during the current public health emergency I am working remotely. Email is the easiest and most reliable way of reaching me at this time. Thank you for your cooperation.

From: Patricia Warren <warren@fotenn.com>
Sent: May 26, 2023 1:30 PM
To: Bernier, John <John.Bernier@ottawa.ca>
Cc: Jack Mangan <JMangan@homestead.ca>; Mark Brule <mbrule@homestead.ca>; Paul Black <black@fotenn.com>
Subject: RE: 200/210 Clearview Avenue - First Resubmission

CAUTION: This email originated from an External Sender. Please do not click links or open attachments unless you recognize the source.

ATTENTION : Ce courriel provient d'un expéditeur externe. Ne cliquez sur aucun lien et n'ouvrez pas de pièce jointe, excepté si vous connaissez l'expéditeur.

Hi John,

Hope you're doing well! Comment 6 under the Adequacy of Services Report comments states that comments would be forwarded as it relates to two sets of services being permitted on the site. Can you confirm if you have received any comments about this?

Thank you!

Patricia Warren, M.Pl.

Planner

T 613.730.5709. ext. 225

St. Marseille, Marina

From: Searle, Daniel
Sent: March 25, 2024 16:31
To: St. Marseille, Marina
Subject: FW: 200 Clearview Discussion

Follow Up Flag: Follow up
Flag Status: Completed

FYI



Daniel Searle

Team Lead, Cornwall
Land Development & Municipal Engineering, Ontario
P.Eng.
(He/Him)

T+ 1 613-933-5602
T+ 1 613-935-0538 (Direct)
M+ 1 613-618-4825



From: Fawzi, Mohammed <mohammed.fawzi@ottawa.ca>
Sent: Monday, March 25, 2024 4:14 PM
To: Searle, Daniel <Daniel.Searle@wsp.com>
Subject: RE: 200 Clearview Discussion

Hi Daniel,

Given that the outlet to the Ottawa River is less than 2km and there is a significant area of hard surface proposed the quality control criteria is 80% TSS removal.

Let me know if you wish to discuss further.

Best Regards,

Mohammed Fawzi, P.Eng.

Project Manager, Infrastructure - Gestionnaire de projet, Projets d'infrastructure
Planning, Infrastructure and Economic Development Department
Development Review All Wards (DRAW)
City of Ottawa | Ville d'Ottawa
110 Laurier Avenue West | 110 Avenue Laurier Ouest

Ottawa, ON K1P 1J1
613.580.2424 ext./poste 20120, Mohammed.Fawzi@ottawa.ca

From: Searle, Daniel <Daniel.Searle@wsp.com>
Sent: Monday, March 25, 2024 1:23 PM
To: Fawzi, Mohammed <mohammed.fawzi@ottawa.ca>
Subject: RE: 200 Clearview Discussion

CAUTION: This email originated from an External Sender. Please do not click links or open attachments unless you recognize the source.

ATTENTION : Ce courriel provient d'un expéditeur externe. Ne cliquez sur aucun lien et n'ouvrez pas de pièce jointe, excepté si vous connaissez l'expéditeur.

Hi Mohammed,

Thanks for the follow-up, look forward to hearing back when you confirm.

Thanks,



Daniel Searle

Team Lead, Cornwall
Land Development & Municipal Engineering, Ontario
P.Eng.
(He/Him)

T+ 1 613-933-5602
T+ 1 613-935-0538 (Direct)
M+ 1 613-618-4825



From: Fawzi, Mohammed <mohammed.fawzi@ottawa.ca>
Sent: Thursday, March 21, 2024 2:59 PM
To: Searle, Daniel <Daniel.Searle@wsp.com>
Subject: RE: 200 Clearview Discussion

Hi Daniel,

Given the amount of hard surface area on site and that we are less than 2km from the outlet to the Ottawa River, quality control measures will be required. The target rate would be 80%TSS removal. We may have to look at proposing LID measures in combination with an OGS unit, as an OGS unit alone does not achieve 80%.

I will get back to you.

Thanks Daniel.

Best Regards,

Mohammed Fawzi, P.Eng.

Project Manager

Planning, Infrastructure and Economic Development Department - Services de la planification, de l'infrastructure et du développement économique

Development Review - Central Branch

City of Ottawa | Ville d'Ottawa

110 Laurier Avenue West Ottawa, ON | 110, avenue. Laurier Ouest. Ottawa (Ontario) K1P 1J1

613.580.2424 ext./poste 20120, Mohammed.Fawzi@ottawa.ca

****Please note that due to the current situation, I am working remotely. Email is currently the best way to contact me****

From: Searle, Daniel <Daniel.Searle@wsp.com>

Sent: Wednesday, March 20, 2024 1:10 PM

To: Fawzi, Mohammed <mohammed.fawzi@ottawa.ca>

Subject: RE: 200 Clearview Discussion

CAUTION: This email originated from an External Sender. Please do not click links or open attachments unless you recognize the source.

ATTENTION : Ce courriel provient d'un expéditeur externe. Ne cliquez sur aucun lien et n'ouvrez pas de pièce jointe, excepté si vous connaissez l'expéditeur.

Hi Mohammed,

Hope you are well.

I had one follow-up question for you on this file, specially 22. a) from the SPA pre-application meeting (see below).

19	Engineering
20	22 The Stormwater Management Criteria, for the subject site, is to be based on the following:
21	22 a) Water Quantity Control: In the absence of area specific SWM criteria, please control post-development runoff from the subject site, up to and including the 100-year storm event, to a pre-development level of 2-year. The pre-development runoff coefficient will need to be determined as per existing conditions but in no case more than 0.5. [If 0.5 applies it needs to be clearly demonstrated in the report that the pre development runoff coefficient is greater than 0.5]. The time of concentration (Tc) used to determine the pre-development condition should be calculated. Tc should not be less than 10 min. since IDF curves become unrealistic at less than 10 min; Tc of 10 minutes shall be used for all post-development calculations]. Water Quality Control: Not required if there will be no surface drainage capture/control infrastructure such as a catch basin, catch basin with ICD.

If our works include catch basins to collect runoff from the internal laneways (hardscape), what would be the quality control target we'd need to meet with our SWM works?

Thanks,



Daniel Searle

Team Lead, Cornwall
Land Development & Municipal Engineering, Ontario
P.Eng.
(He/Him)

T+ 1 613-933-5602
T+ 1 613-935-0538 (Direct)
M+ 1 613-618-4825



From: Fawzi, Mohammed <mohammed.fawzi@ottawa.ca>
Sent: Wednesday, February 28, 2024 10:59 AM
To: Searle, Daniel <Daniel.Searle@wsp.com>
Subject: RE: 200 Clearview Discussion

Hi Daniel,

Please see images below.

2-Year HGL on Clearview System

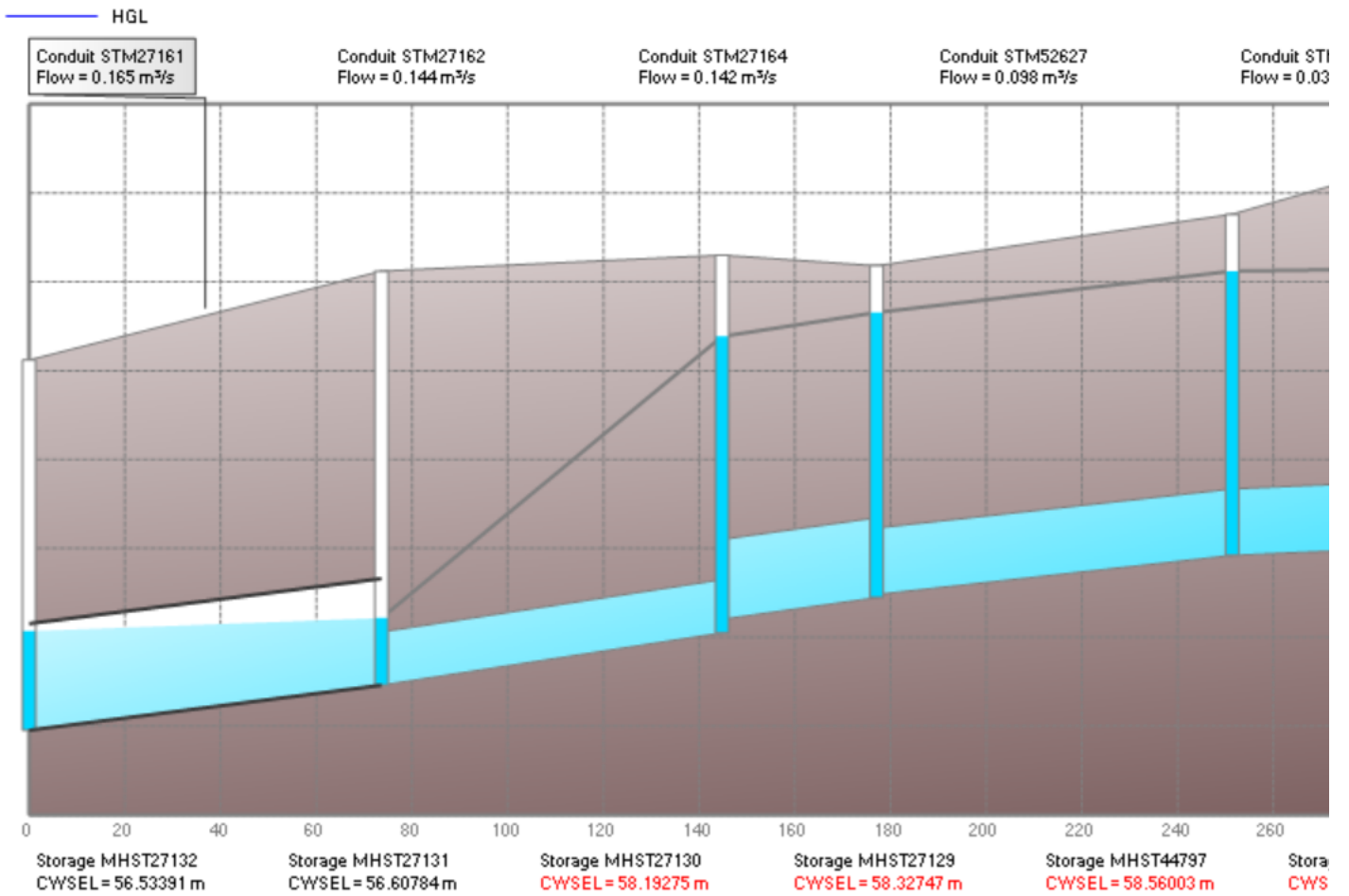

2-Year HGL on Lanark System

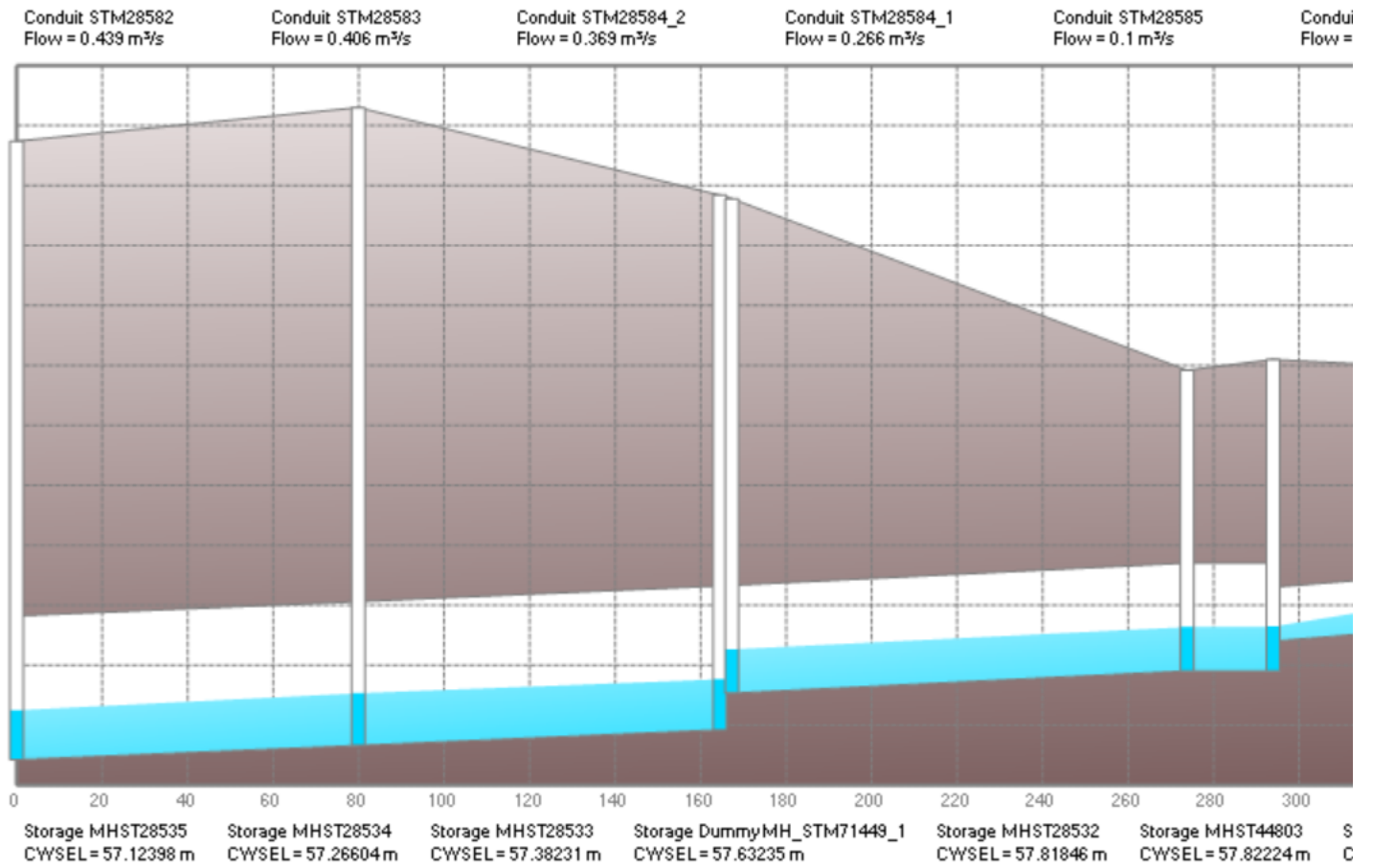

100-Year HGL on Clearview System

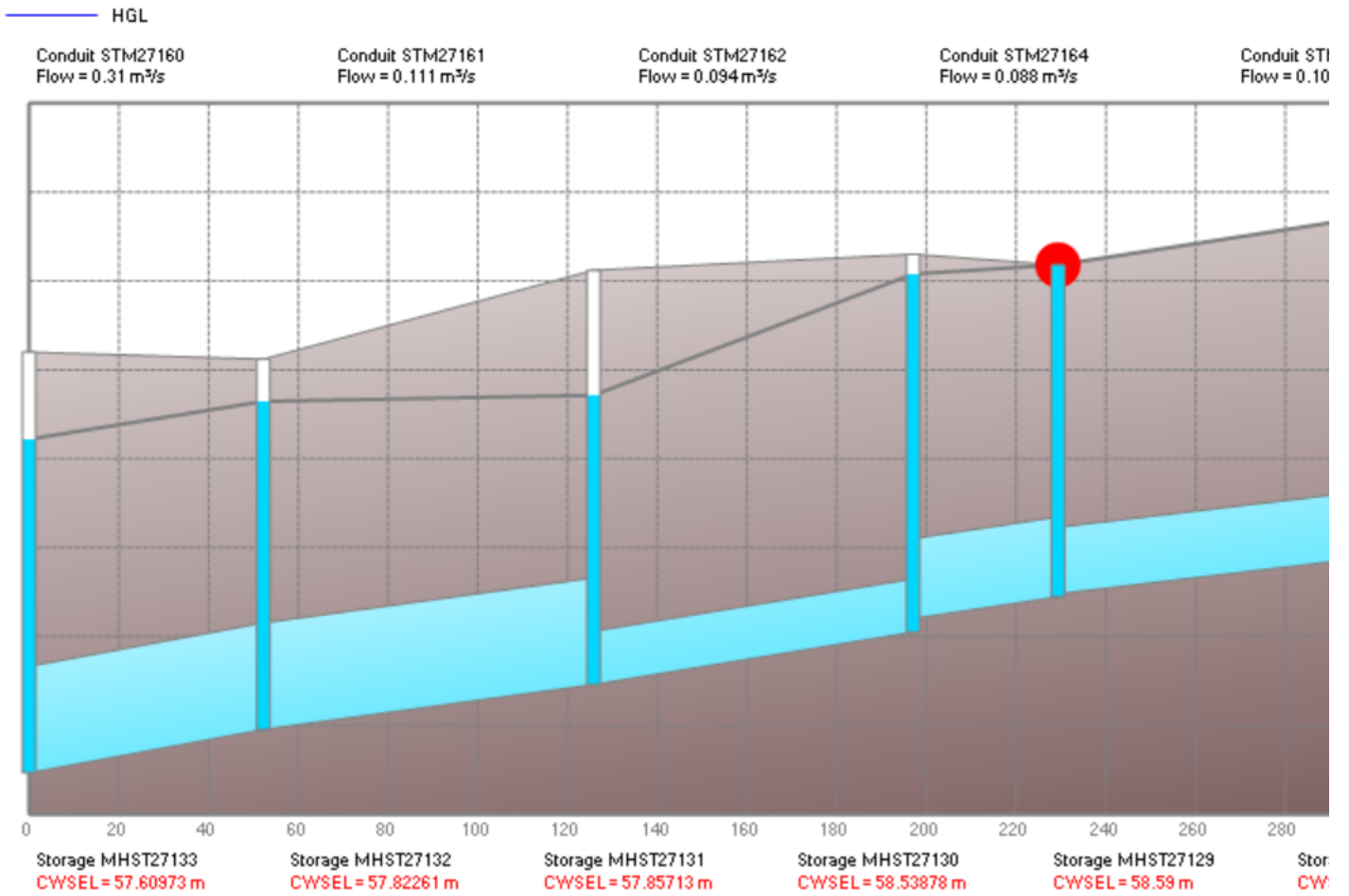

100-Year HGL on Lanark System

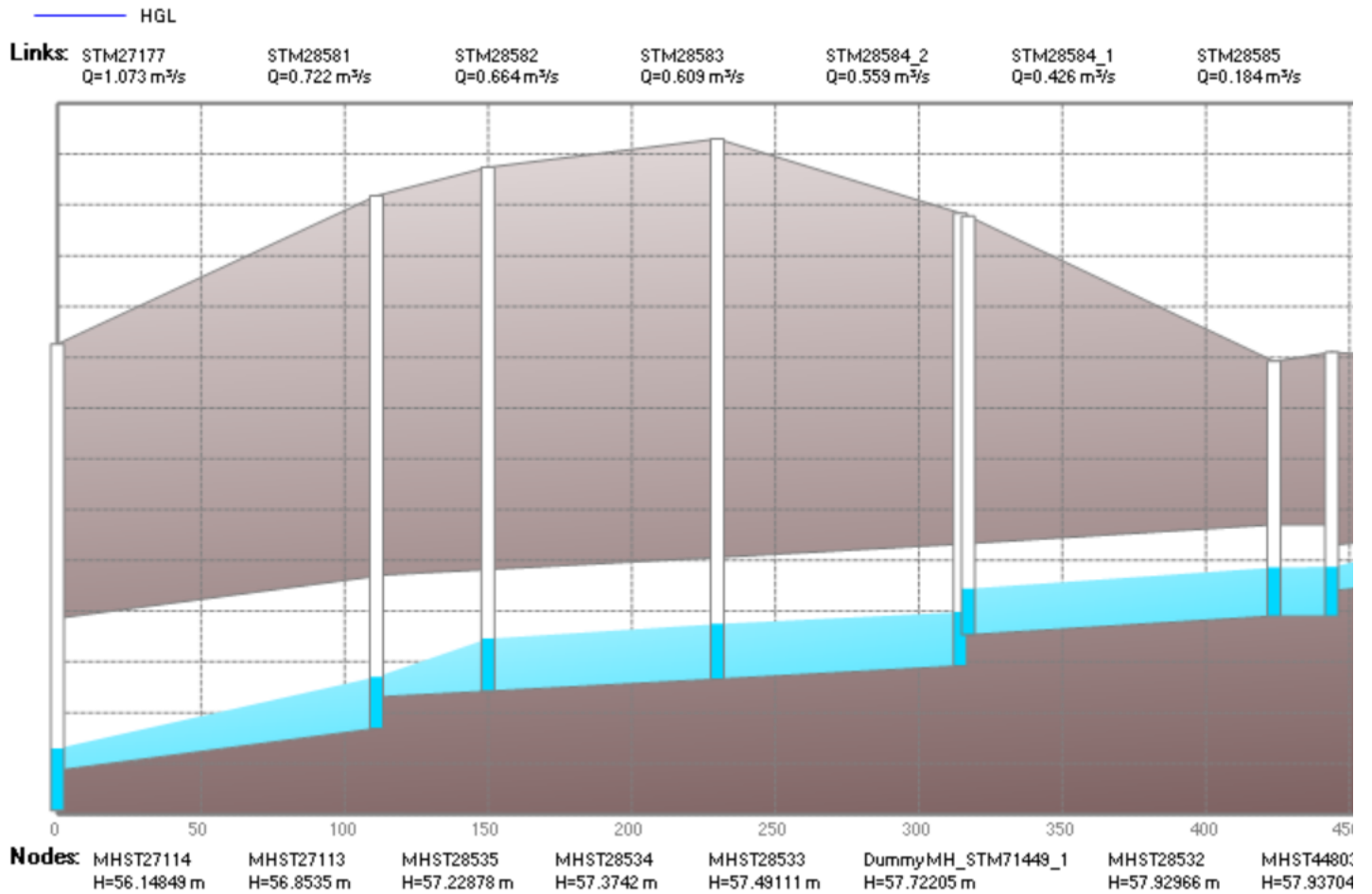

These can be used as boundary conditions but please note that they are approximate but still a reasonable approximation.

Best Regards,

Mohammed Fawzi, P.Eng.

Project Manager

Planning, Infrastructure and Economic Development Department - Services de la planification, de l'infrastructure et du développement économique

Development Review - Central Branch

City of Ottawa | Ville d'Ottawa

110 Laurier Avenue West Ottawa, ON | 110, avenue. Laurier Ouest. Ottawa (Ontario) K1P 1J1

613.580.2424 ext./poste 20120, Mohammed.Fawzi@ottawa.ca

****Please note that due to the current situation, I am working remotely. Email is currently the best way to contact me****

From: Searle, Daniel <Daniel.Searle@wsp.com>
Sent: February 27, 2024 4:20 PM
To: Fawzi, Mohammed <mohammed.fawzi@ottawa.ca>
Subject: RE: 200 Clearview Discussion

CAUTION: This email originated from an External Sender. Please do not click links or open attachments unless you recognize the source.

ATTENTION : Ce courriel provient d'un expéditeur externe. Ne cliquez sur aucun lien et n'ouvrez pas de pièce jointe, excepté si vous connaissez l'expéditeur.

Hi Mohammed,

Thank you for clarifying these sewer items.

For the storm sewers, we would appreciate the City providing the 2-year and 100-year HGL, thank you for offering. Can you please confirm whether it would be acceptable if WSP used these HGLs as our boundary conditions in our stormwater design?

Let me know your thoughts.

Thank you,



Daniel Searle

Municipal – Project Engineer
Land Development & Municipal Engineering
P.Eng.
(He/Him)

T+ 1 613-935-0538 (Direct)
M+ 1 613-618-4825



From: Fawzi, Mohammed <mohammed.fawzi@ottawa.ca>
Sent: Friday, February 23, 2024 10:00 AM
To: Searle, Daniel <Daniel.Searle@wsp.com>
Subject: RE: 200 Clearview Discussion

Hi Daniel,

For the sanitary sewer, during normal conditions, free flow can be assumed. There are no issues with respect to capacity but the area is prone to surcharging, a backwater valve and/or pumping system is highly recommended.

With respect to the storm sewers, both Lanark and Clearview have storm sewers designed with a 2-year level of service. Free flow conditions should not be assumed. The City can provide you with the rough HGL for both the 2-year and 100-year if there are any concerns.

Let me know if you wish to discuss further.

Best Regards,

Mohammed Fawzi, P.Eng.

Project Manager

Planning, Infrastructure and Economic Development Department - Services de la planification, de l'infrastructure et du développement économique

Development Review - Central Branch

City of Ottawa | Ville d'Ottawa

110 Laurier Avenue West Ottawa, ON | 110, avenue. Laurier Ouest. Ottawa (Ontario) K1P 1J1

613.580.2424 ext./poste 20120, Mohammed.Fawzi@ottawa.ca

****Please note that due to the current situation, I am working remotely. Email is currently the best way to contact me****

From: Searle, Daniel <Daniel.Searle@wsp.com>

Sent: February 21, 2024 4:29 PM

To: Fawzi, Mohammed <mohammed.fawzi@ottawa.ca>

Subject: RE: 200 Clearview Discussion

CAUTION: This email originated from an External Sender. Please do not click links or open attachments unless you recognize the source.

ATTENTION : Ce courriel provient d'un expéditeur externe. Ne cliquez sur aucun lien et n'ouvrez pas de pièce jointe, excepté si vous connaissez l'expéditeur.

Hi Mohammed,

Really appreciate your time today.

Please see below a summary of our discussion in relation to select City comments from the attached Pre-Consultation Meeting Feedback Form (Proposed Site Plan Control Application – 200 Clearview Avenue - File No.: PC2024-0006).

Item #	Pre-Consultation: Meeting Feedback Comment (City of Ottawa)	Summary of Discussion (WSP/City) and Actions
Item 12	<i>Water Boundary condition requests must include the location of the service (map or plan with connection location(s) indicated) and the expected loads required by the proposed development, including calculations. Please provide the following information: ...</i>	<ul style="list-style-type: none">- DS requested confirmation as to whether update municipal water servicing hydraulic boundary conditions would be required.- MF confirmed that the previous boundary conditions do not expire and remain valid unless domestic and/or fire flow demands change. If so, a request for updated boundary conditions will be required, accompanied by the new flows.- No further action at this time.

<p>Item 13. a)</p>	<p><i>Water Supply Redundancy: Residential buildings with a basic day demand greater than 50m³/day (0.57 L/s) are required to be connected to a minimum of two water services separated by an isolation valve to avoid a vulnerable service area as per the Ottawa Design Guidelines - Water Distribution, WDG001, July 2010 Clause 4.3.1 Configuration. The basic day demand for this site not expected to exceed 50m³/day.</i></p>	<ul style="list-style-type: none"> - DS indicated that a double water service connection (off Lanark) was proposed in the ZBA submission and remains the current strategy of the applicant. DS also indicated that the average day demands (detailed in the ZBA submission) are higher than the 50 m³/day threshold. - MF indicated this was a general comment and confirmed the proposal appears to align with the requirement. - No further action at this time.
<p>Item 14. m)</p>	<p><i>Modeling can be provided to ensure capacity for both storm and sanitary sewers for the proposed development by City's Water Distribution Dept. – Modeling Group, through PM and upon request.</i></p>	<ul style="list-style-type: none"> - DS asked for clarification as to whether the City would be revisiting available capacity in the proposed receiving municipal sanitary and storm sewers at the SPA stage, even though this was not raised as a concern in the ZBA stage. - MF confirmed the City has <u>no concern</u> with available capacity in the proposed receiving sanitary sewer (Clearview). <ul style="list-style-type: none"> o Action: MF to confirm whether flow free conditions can be assumed (by the applicant) at the proposed connection to the municipal sanitary sewer. - MF confirmed the City has <u>no concern</u> with available capacity in the proposed receiving storm sewer (Clearview) if all post-development flows (up to 100-year) to the municipal storm sewer do not exceed 2-year pre-development flows (as detailed in the ZBA report). <ul style="list-style-type: none"> o Action: MF to confirm whether flow free conditions can be assumed (by the applicant) at the proposed connection to the municipal storm sewer (under all design storm events - up to the 100-year) if the peak allowable release rate of 2-year pre-development is adhered to.

Please advise if you feel I have misinterpreted our discussion in anyway.



Daniel Searle

Municipal – Project Engineer
Land Development & Municipal Engineering
P.Eng.
(He/Him)

T+ 1 613-935-0538 (Direct)
M+ 1 613-618-4825



-----Original Appointment-----

From: Fawzi, Mohammed <mohammed.fawzi@ottawa.ca>

Sent: Wednesday, February 21, 2024 1:02 PM

To: Searle, Daniel

Subject: 200 Clearview Discussion

When: February 21, 2024 2:00 PM-2:30 PM (UTC-05:00) Eastern Time (US & Canada).

Where: Microsoft Teams Meeting

Microsoft Teams [Need help?](#)

[Join the meeting now](#)

Meeting ID: 299 878 101 314

Passcode: d5unur

Dial-in by phone

[+1 613-319-1080](tel:+16133191080),[,347519314#](tel:+16133191080) Canada, Ottawa-Hull

[Find a local number](#)

Phone conference ID: 347 519 314#

Join on a video conferencing device

Tenant key: teams@vc.ottawa.ca

Video ID: 119 440 437 3

[More info](#)

For organizers: [Meeting options](#) | [Reset dial-in PIN](#)

This e-mail originates from the City of Ottawa e-mail system. Any distribution, use or copying of this e-mail or the information it contains by other than the intended recipient(s) is unauthorized. Thank you.

Le présent courriel a été expédié par le système de courriels de la Ville d'Ottawa. Toute distribution, utilisation ou reproduction du courriel ou des renseignements qui s'y trouvent par une personne autre que son destinataire prévu est interdite. Je vous remercie de votre collaboration.

NOTICE: This communication and any attachments ("this message") may contain information which is privileged, confidential, proprietary or otherwise subject to restricted disclosure under applicable law. This message is for the sole use of the intended recipient(s). Any unauthorized use, disclosure, viewing, copying, alteration, dissemination or distribution of, or reliance on, this message is strictly prohibited. If you have received this message in error, or you are not an authorized or intended recipient, please notify the sender immediately by replying to this message, delete this message and all copies from your e-mail system and destroy any printed copies. You are receiving this communication because you are listed as a current WSP contact. Should you have any questions regarding WSP's electronic communications policy, please consult our Anti-Spam Commitment at www.wsp.com/cas/. For any concern or if you believe you should not be receiving this message, please forward this message to cascompliance@wsp.com so that we can promptly address your request. Note that not all messages sent by WSP qualify as commercial electronic messages.

AVIS : Ce message, incluant tout fichier l'accompagnant (« le message »), peut contenir des renseignements ou de l'information privilégiés, confidentiels, propriétaires ou à divulgation restreinte en vertu de la loi. Ce message est destiné à l'usage exclusif du/des destinataire(s) voulu(s). Toute utilisation non permise, divulgation, lecture, reproduction, modification, diffusion ou distribution est interdite. Si vous avez reçu ce message par erreur, ou que vous n'êtes pas un destinataire autorisé ou voulu, veuillez en aviser l'expéditeur immédiatement et détruire le message et toute copie électronique ou imprimée. Vous recevez cette communication car vous faites partie des contacts de WSP. Si vous avez des questions concernant la politique de communications électroniques de WSP, veuillez consulter notre Engagement anti-pourriel au www.wsp.com/lcap. Pour toute question ou si vous croyez que vous ne devriez pas recevoir ce message, prière de le transférer au conformitelcap@wsp.com afin que nous puissions rapidement traiter votre demande. Notez que ce ne sont pas tous les messages transmis par WSP qui constituent des messages électroniques commerciaux.

-LAEmlHhHzdJzBITWfa4Hgs7pbKl

This e-mail originates from the City of Ottawa e-mail system. Any distribution, use or copying of this e-mail or the information it contains by other than the intended recipient(s) is unauthorized. Thank you.

Le présent courriel a été expédié par le système de courriels de la Ville d'Ottawa. Toute distribution, utilisation ou reproduction du courriel ou des renseignements qui s'y trouvent par une personne autre que son destinataire prévu est interdite. Je vous remercie de votre collaboration.

This e-mail originates from the City of Ottawa e-mail system. Any distribution, use or copying of this e-mail or the information it contains by other than the intended recipient(s) is unauthorized. Thank you.

Le présent courriel a été expédié par le système de courriels de la Ville d'Ottawa. Toute distribution, utilisation ou reproduction du courriel ou des renseignements qui s'y trouvent par une personne autre que son destinataire prévu est interdite. Je vous remercie de votre collaboration.

This e-mail originates from the City of Ottawa e-mail system. Any distribution, use or copying of this e-mail or the information it contains by other than the intended recipient(s) is unauthorized. Thank you.

Le présent courriel a été expédié par le système de courriels de la Ville d'Ottawa. Toute distribution, utilisation ou reproduction du courriel ou des renseignements qui s'y trouvent par une personne autre que son destinataire prévu est interdite. Je vous remercie de votre collaboration.

This e-mail originates from the City of Ottawa e-mail system. Any distribution, use or copying of this e-mail or the information it contains by other than the intended recipient(s) is unauthorized. Thank you.

Le présent courriel a été expédié par le système de courriels de la Ville d'Ottawa. Toute distribution, utilisation ou reproduction du courriel ou des renseignements qui s'y trouvent par une personne autre que son destinataire prévu est interdite. Je vous remercie de votre collaboration.

Patricia Warren
Fotenn Planning + Design
Via email: warren@fotenn.com

**Subject: Pre-Consultation: Meeting Feedback
Proposed Site Plan Control Application – 200 Clearview Avenue**

Please find below information regarding next steps as well as consolidated comments from the above-noted pre-consultation meeting held on February 1, 2024.

Pre-Consultation Preliminary Assessment

1 <input type="checkbox"/>	2 <input type="checkbox"/>	3 <input type="checkbox"/>	4 <input checked="" type="checkbox"/>	5 <input type="checkbox"/>
----------------------------	----------------------------	----------------------------	---------------------------------------	----------------------------

One (1) indicates that considerable major revisions are required while five (5) suggests that the proposal appears to meet the City's key land use policies and guidelines. This assessment is purely advisory and does not consider technical aspects of the proposal or in any way guarantee application approval.

Next Steps

1. A review of the proposal and materials submitted for the above-noted pre-consultation has been undertaken. Please proceed to Phase 3 Pre-consultation Application Form and submit it together with the necessary studies and/or plans to planningcirculations@ottawa.ca.
2. In your subsequent pre-consultation submission, please ensure that all comments or issues detailed herein are addressed. A detailed cover letter stating how each issue has been addressed must be included with the submission materials. Please coordinate the numbering of your responses within the cover letter with the comment number(s) herein.
3. Please note, if your development proposal changes significantly in scope, design, or density before the Phase 3 pre-consultation, you may be required to complete or repeat the Phase 2 pre-consultation process.

Supporting Information and Material Requirements

1. The attached **Study and Plan Identification List** outlines the information and material that has been identified, during this phase of pre-consultation, as either required (R) or advised (A) as part of a future complete application submission.
 - a. The required plans and studies must meet the City's Terms of Reference (ToR) and/or Guidelines, as available on Ottawa.ca. These ToR and Guidelines outline

the specific requirements that must be met for each plan or study to be deemed adequate.

Consultation with Technical Agencies

1. You are encouraged to consult with technical agencies early in the development process and throughout the development of your project concept. A list of technical agencies and their contact information is enclosed.

Planning

Comments:

1. Please consider family size units.
2. Please ensure accessibility standards are met.
3. Provide a plan describing the design of the rooftop amenity.
4. We will accept a Phase 3, but will need to put a hold on the file until the ZBA and OPA appeal is resolved.
5. Section 131 - Planned Unit Development Provisions apply.
 - Min 6m for a private way. This may pose an issue to the access lane off of Lanark. A Minor Variance would be required.
 - ***Private way means a privately-owned driveway, aisle or parking lot that leads to a public street, including a privately-owned driveway, aisle or parking lot within a planned unit development that leads to a public street. (voie privée) (By-law 2010-307)***
6. Waste Management: Connected with WCS and they have no issues with the proposed (based on the floor plans from the ZBA/OPA)
7. Trees/Landscaping:
 - Preserving the row next to the loading area?
 - Adding to this buffer.
 - We question the survivability of the trees on top of parking garage. Please provide a detail on the landscape plan which includes soil volumes.
8. Community Benefits Charge
 - a. The former Section 37 regime has been replaced with a “Community Benefits Charge”, [By-law No. 2022-307](#), of 4% of the land value. This charge will be required for ALL buildings that are 5 or more storeys and 10 or more units and will be required at the time of building permit unless the



development is subject to an existing registered Section 37 agreement. Questions regarding this change can be directed to Ranbir.Singh@ottawa.ca.

Urban Design

Submission Requirements:

9. An Urban Design Brief is required. Please see attached customized Terms of Reference to guide the preparation of the submission.
 - a. The Urban Design Brief should be structured by generally following the headings highlighted under **Section 3 – Contents of these Terms of Reference**.
 - b. The following elements are particularly important for this development application:
 - Ground floor relationships.

Comments on Preliminary Design:

10. The Site plan has not been updated from the re-zoning application stage, so more material needs to be submitted for us to perform a fulsome review

Recommendations:

11. We recommend the ground floor be detailed in the application to facilitate review of site relationships and grade related units.

Feel free to contact Christopher Moise, Urban Designer, Architect, for follow-up questions.

Engineering

Comments:

22. The Stormwater Management Criteria, for the subject site, is to be based on the following:
 - a) **Water Quantity Control:** In the absence of area specific SWM criteria, please control post-development runoff from the subject site, up to and including the **100-year storm event**, to a **pre-development level of 2-year**. The pre-development runoff coefficient will need to be determined **as per existing conditions** but in no case more than 0.5. **[If 0.5 applies it needs to be clearly demonstrated in the report that the pre-development runoff coefficient is greater than 0.5]**. The time of

concentration (T_c) used to determine the pre-development condition should be calculated. *T_c should not be less than 10 min. since IDF curves become unrealistic at less than 10 min; T_c of 10 minutes shall be used for all post-development calculations*].

Any storm events greater than the established **2-year allowable** release rate, up to and including the **100-year storm event**, shall be detained on-site. The SWM measures required to avoid impact on the downstream sewer system will be subject to review.

Water Quality Control: Not required if there will be no surface drainage capture/control infrastructure such as a catch basin, catch basin with ICD.

12. Water Boundary condition requests must include the location of the service (map or plan with connection location(s) indicated) and the expected loads required by the proposed development, including calculations. Please provide the following information:

- a. Location of service
- b. Type of development and the amount of fire flow required (as per FUS).
- c. Average daily demand: ___ l/s.
- d. Maximum daily demand: ___ l/s.
- e. Maximum hourly daily demand: ___ l/s.

13. Water

- a) Water Supply Redundancy: Residential buildings with a basic day demand greater than 50m³/day (0.57 L/s) are required to be connected to a minimum of two water services separated by an isolation valve to avoid a vulnerable service area as per the Ottawa Design Guidelines - Water Distribution, WDG001, July 2010 Clause 4.3.1 Configuration. The basic day demand for this site not expected to exceed 50m³/day.
- b) Please review Technical Bulletin ISTB-2018-02, maximum fire flow hydrant capacity is provided in Section 3 Table 1 of Appendix I. A hydrant coverage figure shall be provided and demonstrate there is adequate fire protection for the proposal. Two or more public hydrants are anticipated to be required to handle fire flow.
- c) Existing residential service(s) to be blanked at the main.

14. Sewer (sanitary and storm)

- a) A storm sewer monitoring maintenance hole is required to be installed at the property line (on the private side of the property) as per City of Ottawa Sewer-Use By-Law 2003-514 (14) Monitoring Devices.

- b) Sanitary sewer monitoring maintenance hole is required to be installed at the property line (on the private side of the property) as per City of Ottawa Sewer-Use By-Law 2003-514 (14) Monitoring Devices.
- c) Document how any foundation drainage system will be integrated into the servicing design and show the positive outlet on the plan. Foundation drainage is to be independently connected to sewer main unless being pumped with appropriate back up power, sufficient sized pump and back flow prevention. It is recommended that the foundation drainage system be drained by a sump pump connection to the storm sewer to minimize risk of basement flooding as it will provide the best protection from the uncontrolled sewer system compared to relying on the backwater valve.
- d) Please note that the minimum orifice dia. for a plug style ICD is 83mm and the minimum flow rate from a vortex ICD is 6 L/s in order to reduce the likelihood of plugging.
- e) Please provide a Pre-Development Drainage Area Plan to define the pre-development drainage areas/patterns. Existing drainage patterns shall be maintained and discussed as part of the proposed SWM solution.
- f) Post-development site grading shall match existing property line grades in order to minimize disruption to the adjacent residential properties. A **topographical plan of survey** shall be provided as part of the submission and a note provided on the plans.
- g) There must be at least **15cm of vertical clearance** between the spill elevation and the ground elevation at the building envelope that is in proximity of the flow route or ponding area. The exception in this case would be at reverse sloped loading dock locations. At these locations, a minimum of 15cm of vertical clearance must be provided below loading dock openings. Ensure to provide discussion in report and ensure grading plan matches if applicable.
- h) **Underground Storage:** Please note that the Modified Rational Method for storage computation in the Sewer Design Guidelines was originally intended to be used for above ground storage (i.e., parking lot) where the change in head over the orifice varied from 1.5 m to 1.2 m (assuming a 1.2 m deep CB and a max ponding depth of 0.3 m). This change in head was small and hence the release rate fluctuated little, therefore there was no need to use an average release rate.
- i) When underground storage is used, the release rate fluctuates from a maximum peak flow based on maximum head down to a release rate of zero. This difference is large and has a significant impact on storage requirements. **We therefore require that an average release rate equal to 50% of the peak allowable rate shall be applied to estimate the required volume. Alternatively, the consultant may choose to use a submersible pump in the design to ensure a constant release rate.**
- j) If there is a disagreement from the designer regarding the required storage, the City will require that the designer demonstrate their rationale utilizing dynamic modelling, that will then be reviewed by City modellers in the Water Resources Group.

- k) Provide information on type of underground storage system including product name and model, number of chambers, chamber configuration, confirm invert of chamber system, top of chamber system, required cover over system and details, interior bottom slope (for self-cleansing), chart of storage values, length, width and height, capacity, entry ports (maintenance) etc. UG storage to provide actual 2- and 100-year event storage requirements.
- l) In regard to all proposed UG storage, ground water levels (and in particular HGW levels) will need to be reviewed to ensure that the proposed system does not become surcharged and thereby ineffective.
- m) Modeling can be provided to ensure capacity for both storm and sanitary sewers for the proposed development by City's Water Distribution Dept. – Modeling Group, through PM and upon request.
- n) If rooftop control and storage is proposed as part of the SWM solutions sufficient details (Cl. 8.3.8.4) shall be discussed and document in the report and on the plans. Roof drains are to be connected downstream of any incorporated ICDs within the SWM system and not to the foundation drain system. Provide a Roof Drain Plan as part of the submission.
- o) Street catch basins are not to be located at any proposed entrances.
- p) Sewer connections to be made above the springline of the sewermain as per:
 - i. Std Dwg S11.1 for flexible main sewers – connections made using approved tee or wye fittings.
 - ii. Std Dwg S11 (For rigid main sewers) – lateral must be less than 50% the diameter of the sewermain,
 - iii. Std Dwg S11.2 (for rigid main sewers using bell end insert method) – for larger diameter laterals where manufactured inserts are not available; lateral must be less than 50% the diameter of the sewermain,
 - iv. Connections to manholes permitted when the connection is to rigid main sewers where the lateral exceeds 50% the diameter of the sewermain. – Connect obvert to obvert with the outlet pipe unless pipes are a similar size.
 - v. No submerged outlet connections.

30. Grading

Post-development site grading shall match existing property line grades to minimize disruption to the adjacent residential properties. A **topographical plan of survey** shall be provided as part of the submission and a note provided on the plans.

31. Geotechnical (including sensitive marine clay, where appropriate)

Geotechnical Study shall be consistent with the Geotechnical Investigation and Reporting Guidelines for Development Applications.

<https://documents.ottawa.ca/sites/default/files/documents/cap137602.pdf>

32. Snow Storage

Any portion of the subject property which is intended to be used for permanent or temporary snow storage shall be as shown on the approved site plan and grading plan. Snow storage shall not interfere with approved grading and drainage patterns or servicing. Snow storage areas shall be setback from the property lines, foundations, fencing or landscaping a minimum of 1.5m. Snow storage areas shall not occupy driveways, aisles, required parking spaces or any portion of a road allowance. If snow is to be removed from the site please indicate this on the plan(s).

33. Road Reinstatement

Where servicing involves three or more service trenches, either a full road width or full lane width 40 mm asphalt overlay will be required, as per amended Road Activity By- Law 2003-445 and City Standard Detail Drawing R10. The amount of overlay will depend on condition of roadway and width of roadway(s).

34. Gas pressure regulating station

A gas pressure regulating station may be required depending on HVAC needs (typically for 12+ units). Be sure to include this on the Grading, Site Servicing, SWM and Landscape plans. This is to ensure that there are no barriers for overland flow routes (SWM) or conflicts with any proposed grading or landscape features with installed structures and has nothing to do with supply and demand of any product.

35. Phase One Environmental Site Assessment

- a) A Phase I ESA is required to be completed in accordance with Ontario Regulation 153/04 in support of this development proposal to determine the potential for site contamination. Depending on the Phase I recommendations a Phase II ESA may be required.
- b) The Phase I ESA shall provide all the required Environmental Source Information as required by O. Reg. 153/04. ERIS records are available to public at a reasonable cost and need to be included in the ESA report to comply with O.Reg. 153/04 and the Official Plan. The City will not be in a position to approve the Phase I ESA without the inclusion of the ERIS reports.
- c) Official Plan Section 10.1.6

36. General

- a. It is the sole responsibility of the consultant to investigate the location of existing underground utilities in the proposed servicing area and submit a request for locates to avoid conflict(s). The location of existing utilities and services shall be documented on an **Existing Conditions Plan**.
- b. Any easements on the subject site shall be identified and respected by any development proposal and shall adhere to the conditions identified in the easement agreement. A **legal survey plan** shall be provided, and all easements shall be shown on the engineering plans.

- c. All underground and above ground building footprints and permanent walls need to be shown on the plans to confirm that any permanent structure does not extend either above or below into the existing property lines and sight triangles.
- d. **Construction approach** – Please contact the Right-of-Ways Permit Office TMconstruction@ottawa.ca early in the Site Plan process to determine the ability to construct site and copy File Lead on this request.

Feel free to contact Mohammed Fawzi, Infrastructure Project Manager, for follow-up questions.

Noise

Comments:

1. A **Transportation Noise Assessment** is required as the subject development fronts a collector road.
2. A **Stationary Noise Assessment** is required to assess the noise impact of the proposed sources of stationary noise (mechanical HVAC system/equipment) of the development onto the surrounding residential area to ensure the noise levels do not exceed allowable limits specified in the City Environmental Noise Control Guidelines.
3. **Detailed Noise Study** in Support of Class 1 Designation that verifies applicable sound level limits will be met at the new noise sensitive land use with the appropriate mitigation measures for all noise sources to achieve a Class 1 designation to include in Appendix A of Part 1 of the ENCG, pursuant to the ENCG and NPC-300.

Feel free to contact Mohammed Fawzi for follow-up questions.

Transportation

Comments:

15. Please update the TIA to include the required modules for site plan application. Ensure the number of units is updated per the site plan.
16. There is a proposed pedestrian crossover -PXO on Lanark. Provide evaluation of appropriate PXO type per OTM Book 15 in the TIA. RMA will be required for the PXO.
17. Provide truck turning movements for the loading and at the access – entering and exiting.
18. Remove crosswalk from the access at Lanark.

19. As the site proposed is residential, AODA legislation applies for all areas accessible to the public (i.e. outdoor pathways, parking, etc.).
- Clearly define accessible parking stalls and ensure they meet AODA standards (include an access aisle next to the parking stall and a pedestrian curb ramp at the end of the access aisle, as required).
 - For the internal crosswalk, ensure the curbs are depressed and TWSI's are added as required.

Please consider using the City's Accessibility Design Standards, which provide a summary of AODA requirements. <https://ottawa.ca/en/city-hall/creating-equal-inclusive-and-diverse-city/accessibility-services/accessibility-design-standards-features#accessibility-design-standards>

20. The development proponent should protect the corner triangle at intersections per policies 2.1.1 (e) & (f). The City requires a 3 metre x 9 metre triangle, with the longer portion located on, the higher order road segment for intersections with the following characteristics:
- Collector (Ellendale Crescent) and local (Lanark Avenue)

If there is existing underground parking infrastructure and the corner triangle cannot be provided, please provide this information for consideration.

Feel free to contact **Neeti Paudel**, Transportation Project Manager, for follow-up questions.

Environment and Trees

Comments:

21. The City's Bird Safe Design Guidelines will be required at Site Plan Control application.
22. Please, ensure there is sufficient room and space for trees and shrubs to survive.
23. An updated TCR and a landscape plan will be required; guidelines have been provided below. Removal of boundary/adjacent trees will not be supported if trees are healthy and retainable; where possible, retention of existing trees should be prioritized.
24. The following Tree Conservation Report (TCR) guidelines have been adapted from the Schedule E of the Tree Protection By-law – for more information on these requirements please contact julian.alvarez-barkham@ottawa.ca

- a. A Tree Conservation Report (TCR) must be supplied for review along with the suite of other plans/reports required by the City
 - i. An approved TCR is a requirement of Site Plan approval.
- b. Any removal of privately-owned trees 10cm or larger in diameter, or city-owned trees of any diameter requires a tree permit issued under the Tree Protection Bylaw (Bylaw 2020 – 340); the permit will be based on an approved TCR and made available at or near plan approval.
- c. The TCR must contain 2 separate plans:
 - i. Plan/Map 1 - show existing conditions with tree cover information.
 - ii. Plan/Map 2 - show proposed development with tree cover information.
- d. The TCR must list all trees on site, as well as off-site trees if the CRZ (critical root zone) extends into the developed area, by species, diameter, and health condition.
 - i. For ease of review, the Planning Forester suggests that all trees be numbered and referenced in an inventory table.
- e. Please identify trees by ownership – private onsite, private on adjoining site, city owned, co-owned (trees on a property line)
- f. If trees are to be removed, the TCR must clearly show where they are, and document the reason they cannot be retained.
 - i. Compensation may be required for the removal of city owned trees.
- g. The removal of trees on a property line will require the permission of both property owners.
- h. All retained trees must be shown, and all retained trees within the area impacted by the development process must be protected as per City guidelines available on the Tree Protection Specification or by searching Ottawa.ca.
 - i. The location of tree protection fencing must be shown on the plan;
 - ii. Show the critical root zone of the retained trees.
- i. The City encourages the retention of healthy trees; if possible, please seek opportunities for retention of trees that will contribute to the design/function of the site.

25. The following Landscape Plan (LP) guidelines have been adapted from the Schedule E of the Tree Protection By-law – for more information on these requirements please contact julian.alvarez-barkham@ottawa.ca

- a. Please ensure any retained trees are shown on the LP.
- b. Minimum Setbacks
 - i. Maintain 1.5m from sidewalk or MUP/cycle track or water service laterals.
 - ii. Maintain 2.5m from curb.
- b. Coniferous species require a minimum 4.5m setback from curb, sidewalk, or MUP/cycle track/pathway.

- c. Maintain 7.5m between large growing trees, and 4m between small growing trees. Park or open space planting should consider 10m spacing, except where otherwise approved in naturalization / afforestation areas.
- d. Adhere to Ottawa Hydro’s planting guidelines (species and setbacks) when planting around overhead primary conductors.
- e. Tree specifications
 - i. Minimum stock size: 50mm tree caliper for deciduous, 200cm height for coniferous.
 - ii. Maximize the use of large deciduous species wherever possible to maximize future canopy coverage
- f. Tree planting on city property shall be in accordance with the City of Ottawa’s Tree Planting Specification; and if possible, include watering and warranty as described in the specification.
- g. No root barriers, dead-man anchor systems, or planters are permitted.
- h. No tree stakes unless necessary (and only 1 on the prevailing winds side of the tree)
- i. Hard surface planting
 - i. If there are hard surface plantings, a planting detail must be provided.
 - ii. Curb style planter design is highly recommended.
 - iii. No grates are to be used and if guards are required, City of Ottawa standard (which can be provided) shall be used.
- c. Trees are to be planted at grade.
- d. Soil Volume - Please demonstrate as per the **Landscape Plan Terms of Reference** that the available soil volumes for new plantings will meet or exceed the following:

Tree Type/Size	Single Tree Soil Volume (m3)	Multiple Tree Soil Volume (m3/tree)
Ornamental	15	9
Columnar	15	9
Small	20	12
Medium	25	15
Large	30	18
Conifer	25	15

- i. It is strongly suggested that the proposed species list include a column listing the available soil volume.
- e. Sensitive Marine Clay - Please follow the City’s 2017 Tree Planting in Sensitive Marine Clay guidelines.
- f. The City requests that consideration be given to planting native species wherever there is a high probability of survival to maturity.
- g. Efforts shall be made to provide as much future canopy cover as possible at a site level, through tree planting and tree retention. The

Landscape Plan shall show/document that the proposed tree planting and retention will contribute to the City's overall canopy cover over time. **Please provide a projection of the future canopy cover for the site to 40 years.**

Feel free to contact Sami Rehman, Environmental Planner, or Julian Alvarez-Barkham, Forester, for follow-up questions.

Parkland

Comments:

26. Cash-in-lieu of Parkland (CILP) will be required, at the rate specified in the Parkland Dedication By-law No.2022-280 (or as amended).
 - a. CILP rate for residential uses > 18 units/net ha = one hectare per 1,000 net residential units but shall not exceed a maximum of 10% of the gross land area where the land is less than or equal to five hectares.
 - b. CILP rate for commercial uses = 2% of gross land area
 - c. Where land is developed for a mix of uses within a building, the conveyance requirement shall be the cumulative sum for each use, as calculated using the applicable rate prorated proportionally to the gross floor area allocated to each use
27. In the next submission, Parks staff request the following information to calculate the CILP:
 - a. Lot area, in square meters
 - b. Number of existing/proposed residential units
 - c. Total Gross Floor area
 - d. Gross floor area of residential uses
 - e. Gross floor area of commercial uses

Feel free to contact Mike Russet, Parks Planner, for follow-up questions.

Other

28. The High Performance Development Standard (HPDS) is a collection of voluntary and required standards that raise the performance of new building projects to achieve sustainable and resilient design. The HPDS was passed by Council on April 13, 2022.



- a. At this time, the HPDS is not in effect and Council has referred the 2023 HPDS Update Report back to staff with direction to bring forward an updated report to Committee with recommendations for revised phasing timelines, resource requirements and associated amendments to the Site Plan Control By-law by no later than Q1 2024.
 - b. Please refer to the HPDS information attached and ottawa.ca/HPDS for more information.
29. Please, review and implement accessibility standards. ADS Checklist is included into a follow-up package.

Should there be any questions, please do not hesitate to contact myself or the contact identified for the above areas / disciplines.

Yours Truly,
Masha Wakula

- c.c. John Bernier
- Christopher Moise
- Mohammed Fawzi
- Abdul Mottalib
- Neeti Paudel
- Julian Alvarez-Barkham
- Mark Richardson
- Mike Russet
- Amy MacPherson

Servicing study guidelines for development applications

4. Development Servicing Study Checklist

The following section describes the checklist of the required content of servicing studies. It is expected that the proponent will address each one of the following items for the study to be deemed complete and ready for review by City of Ottawa Infrastructure Approvals staff.

The level of required detail in the Servicing Study will increase depending on the type of application. For example, for Official Plan amendments and re-zoning applications, the main issues will be to determine the capacity requirements for the proposed change in land use and confirm this against the existing capacity constraint, and to define the solutions, phasing of works and the financing of works to address the capacity constraint. For subdivisions and site plans, the above will be required with additional detailed information supporting the servicing within the development boundary.

4.1 General Content

- Executive Summary (for larger reports only).
- Date and revision number of the report.
- Location map and plan showing municipal address, boundary, and layout of proposed development.
- Plan showing the site and location of all existing services.
- Development statistics, land use, density, adherence to zoning and official plan, and reference to applicable subwatershed and watershed plans that provide context to which individual developments must adhere.
- Summary of Pre-consultation Meetings with City and other approval agencies.
- Reference and confirm conformance to higher level studies and reports (Master Servicing Studies, Environmental Assessments, Community Design Plans), or in the case where it is not in conformance, the proponent must provide justification and develop a defensible design criteria.
- Statement of objectives and servicing criteria.
- Identification of existing and proposed infrastructure available in the immediate area.
- Identification of Environmentally Significant Areas, watercourses and Municipal Drains potentially impacted by the proposed development (Reference can be made to the Natural Heritage Studies, if available).
- Concept level master grading plan to confirm existing and proposed grades in the development. This is required to confirm the feasibility of proposed stormwater management and drainage, soil removal and fill constraints, and potential impacts to neighbouring properties. This is also required to confirm that the proposed grading will not impede existing major system flow paths.
- Identification of potential impacts of proposed piped services on private services (such as wells and septic fields on adjacent lands) and mitigation required to address potential impacts.
- Proposed phasing of the development, if applicable.

- Reference to geotechnical studies and recommendations concerning servicing.

- All preliminary and formal site plan submissions should have the following information:
 - Metric scale

 - North arrow (including construction North)

 - Key plan

 - Name and contact information of applicant and property owner

 - Property limits including bearings and dimensions

 - Existing and proposed structures and parking areas

 - Easements, road widening and rights-of-way

 - Adjacent street names

4.2 Development Servicing Report: Water

- Confirm consistency with Master Servicing Study, if available
- Availability of public infrastructure to service proposed development
- Identification of system constraints
- Identify boundary conditions
- Confirmation of adequate domestic supply and pressure
- Confirmation of adequate fire flow protection and confirmation that fire flow is calculated as per the Fire Underwriter's Survey. Output should show available fire flow at locations throughout the development.
- Provide a check of high pressures. If pressure is found to be high, an assessment is required to confirm the application of pressure reducing valves.
- Definition of phasing constraints. Hydraulic modeling is required to confirm servicing for all defined phases of the project including the ultimate design
- Address reliability requirements such as appropriate location of shut-off valves
- Check on the necessity of a pressure zone boundary modification.
- Reference to water supply analysis to show that major infrastructure is capable of delivering sufficient water for the proposed land use. This includes data that shows that the expected demands under average day, peak hour and fire flow conditions provide water within the required pressure range

- Description of the proposed water distribution network, including locations of proposed connections to the existing system, provisions for necessary looping, and appurtenances (valves, pressure reducing valves, valve chambers, and fire hydrants) including special metering provisions.
- Description of off-site required feeder mains, booster pumping stations, and other water infrastructure that will be ultimately required to service proposed development, including financing, interim facilities, and timing of implementation.
- Confirmation that water demands are calculated based on the City of Ottawa Design Guidelines.
- Provision of a model schematic showing the boundary conditions locations, streets, parcels, and building locations for reference.

4.3 Development Servicing Report: Wastewater

- Summary of proposed design criteria (Note: Wet-weather flow criteria should not deviate from the City of Ottawa Sewer Design Guidelines. Monitored flow data from relatively new infrastructure cannot be used to justify capacity requirements for proposed infrastructure).
- Confirm consistency with Master Servicing Study and/or justifications for deviations.
- Consideration of local conditions that may contribute to extraneous flows that are higher than the recommended flows in the guidelines. This includes groundwater and soil conditions, and age and condition of sewers.
- Description of existing sanitary sewer available for discharge of wastewater from proposed development.
- Verify available capacity in downstream sanitary sewer and/or identification of upgrades necessary to service the proposed development. (Reference can be made to previously completed Master Servicing Study if applicable)
- Calculations related to dry-weather and wet-weather flow rates from the development in standard MOE sanitary sewer design table (Appendix 'C') format.
- Description of proposed sewer network including sewers, pumping stations, and forcemains.
- Discussion of previously identified environmental constraints and impact on servicing (environmental constraints are related to limitations imposed on the development in order to preserve the physical condition of watercourses, vegetation, soil cover, as well as protecting against water quantity and quality).
- Pumping stations: impacts of proposed development on existing pumping stations or requirements for new pumping station to service development.
- Forcemain capacity in terms of operational redundancy, surge pressure and maximum flow velocity.
- Identification and implementation of the emergency overflow from sanitary pumping stations in relation to the hydraulic grade line to protect against basement flooding.
- Special considerations such as contamination, corrosive environment etc.

4.4 Development Servicing Report: Stormwater Checklist

- Description of drainage outlets and downstream constraints including legality of outlets (i.e. municipal drain, right-of-way, watercourse, or private property)
- Analysis of available capacity in existing public infrastructure.
- A drawing showing the subject lands, its surroundings, the receiving watercourse, existing drainage patterns, and proposed drainage pattern.
- Water quantity control objective (e.g. controlling post-development peak flows to pre-development level for storm events ranging from the 2 or 5 year event (dependent on the receiving sewer design) to 100 year return period); if other objectives are being applied, a rationale must be included with reference to hydrologic analyses of the potentially affected subwatersheds, taking into account long-term cumulative effects.
- Water Quality control objective (basic, normal or enhanced level of protection based on the sensitivities of the receiving watercourse) and storage requirements.
- Description of the stormwater management concept with facility locations and descriptions with references and supporting information.
- Set-back from private sewage disposal systems.
- Watercourse and hazard lands setbacks.
- Record of pre-consultation with the Ontario Ministry of Environment and the Conservation Authority that has jurisdiction on the affected watershed.
- Confirm consistency with sub-watershed and Master Servicing Study, if applicable study exists.
- Storage requirements (complete with calculations) and conveyance capacity for minor events (1:5 year return period) and major events (1:100 year return period).
- Identification of watercourses within the proposed development and how watercourses will be protected, or, if necessary, altered by the proposed development with applicable approvals.
- Calculate pre and post development peak flow rates including a description of existing site conditions and proposed impervious areas and drainage catchments in comparison to existing conditions.
- Any proposed diversion of drainage catchment areas from one outlet to another.
- Proposed minor and major systems including locations and sizes of stormwater trunk sewers, and stormwater management facilities.
- If quantity control is not proposed, demonstration that downstream system has adequate capacity for the post-development flows up to and including the 100 year return period storm event.
- Identification of potential impacts to receiving watercourses
- Identification of municipal drains and related approval requirements.
- Descriptions of how the conveyance and storage capacity will be achieved for the development.
- 100 year flood levels and major flow routing to protect proposed development from flooding for establishing minimum building elevations (MBE) and overall grading.

- Inclusion of hydraulic analysis including hydraulic grade line elevations.
- Description of approach to erosion and sediment control during construction for the protection of receiving watercourse or drainage corridors.
- Identification of floodplains – proponent to obtain relevant floodplain information from the appropriate Conservation Authority. The proponent may be required to delineate floodplain elevations to the satisfaction of the Conservation Authority if such information is not available or if information does not match current conditions.
- Identification of fill constraints related to floodplain and geotechnical investigation.

4.5 Approval and Permit Requirements: Checklist

The Servicing Study shall provide a list of applicable permits and regulatory approvals necessary for the proposed development as well as the relevant issues affecting each approval. The approval and permitting shall include but not be limited to the following:

- Conservation Authority as the designated approval agency for modification of floodplain, potential impact on fish habitat, proposed works in or adjacent to a watercourse, cut/fill permits and Approval under Lakes and Rivers Improvement Act. The Conservation Authority is not the approval authority for the Lakes and Rivers Improvement Act. Where there are Conservation Authority regulations in place, approval under the Lakes and Rivers Improvement Act is not required, except in cases of dams as defined in the Act.
- Application for Certificate of Approval (CofA) under the Ontario Water Resources Act.
- Changes to Municipal Drains.
- Other permits (National Capital Commission, Parks Canada, Public Works and Government Services Canada, Ministry of Transportation etc.)

4.6 Conclusion Checklist

- Clearly stated conclusions and recommendations
- Comments received from review agencies including the City of Ottawa and information on how the comments were addressed. Final sign-off from the responsible reviewing agency.
- All draft and final reports shall be signed and stamped by a professional Engineer registered in Ontario

APPENDIX

C

SANITARY SYSTEM
CALCULATION



Table A1 - Proposed Development

DESIGNED BY: Marina St. Marseille, EIT
CHECKED BY: Scott Taylor, P.Eng.

Proposed Building Space Allocation

Building Type	No. of Units	Total Capita	Area (ha)
1 Bedroom Unit (1.4 Persons/Unit)	54	76	-
2 Bedroom Unit (2.1 Persons/Unit)	130	273	-
Amenity Space	-	-	0.1235
Total	184	349	0.1235

Table A2 - Sanitary Sewer Calculation

DRAINAGE DESCRIPTION												OUTLET PIPE DATA					
AREA DESCRIPTION	FROM	TO	Contributing Area		Average Daily Flow, Individual* (L/d)	Average Daily Flow (L/s)	M	Cumulative Peak Flow (L/d)	Cumaltive Peak Flow (L/s)	Peak Extraneous Flow (L/s)	Q (L/s)	SIZE (mm)	Slope (%)	CAP (L/s)	Q/Qfull	Velocity (m/s)	
			No.	Ha													
Apartment Building	Manhole	Street		0.54	101,178	1.17	3.44	348,020	4.03	0.18	4.21	150	1.00%	15.2	0.3	0.86	
(Total to ROW)																	
DESIGN PARAMETER				Designed By:								PROJECT:					
Manning's n =	0.013			City of Ottawa Sewer Design Guidelines (2012), Technical Bulletins	Marina St. Marseille, EIT								210 Clearview Avenue				
1 & 2 Bedroom Daily Flow (q)=	280	L/cap/d			Checked By:								LOCATION:				
Amenity Space (q)=	28,000	L/ha/d			Scott Taylor, P.Eng.								Ottawa, Ontario				
Infiltration Rate (I) =	0.33	L/s/Ha			Project Number: 221-08957-00								Date: September 4, 2024				
Peaking Factor (M) = $1+14/(4+P^{0.5}) \times 0.8$	3.44	Harmon Formula															
Notes: Refer to Table A1 for population calculations.																	

**Table A3 - Proposed Domestic Demands
210 Clearview Avenue**

PROPOSED DOMESTIC DEMANDS	REFERENCES
<p>Average Day Demand</p> <p>Residential 280 L/cap/d Other Commercial 28,000 L/gross ha/d</p> <p>Average Day Demand (ADD):</p> <p>Residential Population 349 capita 349 capita x 280 L/cap/d 97,720 L/day ADD_{Residential} = 1.13 L/s</p> <p>Amenity Space 0.1235 ha 0.1235 ha x 28,000 L/gross ha/d 3,458 L/day ADD_{Amenity Space} = 0.04 L/s</p> <p>ADD_{TOTAL} = 1.17 L/s</p>	<p>Ottawa Design Guidelines - Water Distribution (July 2010), Table 4.2 Ottawa Design Guidelines - Water Distribution (July 2010), Table 4.2 Technical Bulletins to Water Design Guidelines</p> <p>Statistics provided by Architect (Project Statistics dated July 31, 2024)</p> <p>Statistics provided by Architect (Project Statistics dated July 31, 2024)</p>
<p>Maximum Day Demand (MDD):</p> <p>Maximum Day Factor_{Residential} = 2.5 x ADD_{Residential} Maximum Day Factor_{Amenity Space} = 2.2 x ADD_{Amenity Space}</p> <p>MDD_{Residential} = 2.83 L/s MDD_{Amenity Space} = 0.09 L/s</p> <p>MDD_{TOTAL} = 2.92 L/s</p>	<p>Ottawa Design Guidelines - Water Distribution (July 2010), Table 4.2 Ottawa Design Guidelines - Water Distribution (July 2010), Table 4.2</p> <p>Average Day Demand x Maximum Day Factor Average Day Demand x Maximum Day Factor</p>
<p>Maximum Hour Demand (MHD):</p> <p>Maximum Day Factor_{Residential} = 2.2 x MDD_{Residential} Maximum Day Factor_{Amenity Space} = 1.8 x MDD_{Amenity Space}</p> <p>MHD_{Residential} = 6.22 L/s MHD_{Amenity Space} = 0.16 L/s</p> <p>MHD_{TOTAL} = 6.38 L/s</p>	<p>Ottawa Design Guidelines - Water Distribution (July 2010), Table 4.2 Ottawa Design Guidelines - Water Distribution (July 2010), Table 4.2</p> <p>Maximum Day Demand x Maximum Hour Factor Maximum Day Demand x Maximum Hour Factor</p>
<p>Designed By: Marina St. Marseille, EIT</p>	<p>Project: 210 Clearview Avenue</p>
<p>Checked By: Scott Taylor, P.Eng.</p>	<p>Location: Ottawa, Ontario</p>
<p>Project Number: 221-08957-00</p>	<p>Dwg. Reference: N/A</p>



Fire Flow Calculation

210 Clearview Avenue FIRE UNDERWRITERS SURVEY FIRE FLOW CALCULATION

A = 2,921 sq.m 31,436 sq.ft (Total Effective Area per FUS 2020)

Formula $F = 220 \times c \times \text{Sq. Root "A"}$

F = the required fire flow in litres per minute c = the coefficient related to type of construction
A = Floor Area (Per FUS (2020), Total Effective Area, 2(b), largest floor area plus 25% of each of 2 adjoining floors)

STEP 1: TYPE OF CONSTRUCTION TO DETERMINE "c" COEFFICIENT

c: 1.5 for Wood Frame Construction c: 1.0 for Ordinary Construction
c: 0.8 for Non-Combustible Construction c: 0.6 for Fire-Resistive Construction

$$F = 220 \times c \quad \underline{0.8} \quad \times \text{Sq. Root "A"} \quad \underline{54.0} \quad = \quad \underline{9,511.3}$$

STEP 2: INCREASE OR DECREASE FOR OCCUPANCY

Non-Combustible (-0.25%) Charge: Limited Combustible (-15%) Charge: Combustible (0%)
Free Burning (+15%) Charge: Rapid Burning (+25%) Charge

"APPLY ONE OF THESE CHARGES TO THE VALUE OBTAINED IN STEP 1 ROUNDED OFF TO THE NEAREST 1000"

$$\text{Value from Step 1} \quad \underline{10,000.0} \quad \times \quad \text{Charge} \quad \underline{0.85} \quad = \quad \underline{8,500.0}$$

STEP 3: DETERMINE THE DECREASE FOR SPRINKLER SYSTEM (See FUS for Details)

Adequately Designed System (NFPA 13) -30%, Partial Building Coverage 30% x % of Total Floor Area Serviced
Standard Water Supply -10%, Partial Building Coverage 10% x % of Total Floor Area Serviced
Fully Supervised System -10%, Partial Building Coverage 10% x % of Total Floor Area Serviced

$$\text{Value from Step 2} \quad \underline{8,500.0} \quad \times \quad \text{Above Value} \quad \underline{0.5} \quad = \quad \underline{4,250.0}$$

$$\text{Value from Step 2} \quad \underline{8,500.0} \quad - \quad \text{Answer from Above} \quad \underline{4,250.0} \quad = \quad \underline{4,250.0}$$

STEP 4: INCREASE FOR EXPOSURE FROM OTHER BUILDINGS

Maximum Exposure: 0 to 3 m (+25%); 3.1 to 10 m (+20%); 10.1 to 20 m (+15%); 20.1 to 30 m (+10%); 30.1 to 45 m (0%)
Exposure Adjustment Charges per Table 6 (FUS, 2020)

THE TOTAL % SHALL BE THE SUM OF THE % FOR ALL SIDES, BUT SHALL NOT EXCEED 75%

Value from Step 2	<u>8,500</u>	x	North Side Step Charge	<u>0.10</u>	=	<u>850</u>
Value from Step 2	<u>8,500</u>	x	East Side Step Charge	<u>0.00</u>	=	<u>0</u>
Value from Step 2	<u>8,500</u>	x	South Side Step Charge	<u>0.00</u>	=	<u>0</u>
Value from Step 2	<u>8,500</u>	x	West Side Step Charge	<u>0.00</u>	=	<u>0</u>
			Total	<u>0.1</u>	=	<u>850</u>

$$\text{Value from Step 3} \quad \underline{4,250} \quad + \quad \text{Total} \quad \underline{850} \quad = \quad \underline{5,100}$$

STEP 5: TO DETERMINE THE FIRE FLOW

Round to nearest 1000

$$\text{Take Value from Step 4} \quad \underline{5,000} \quad \text{Divide by 60} \quad = \quad \underline{83.3} \quad \text{L/S}$$

NOTES:

- Total effective area has been calculated assuming all vertical opening and exterior communications are properly protected in accordance with the National Building Code. Floor area 1947m² plus 25% of floor areas 1947m² and 1947m² were used.
- Non combustibile construction type has been assumed.
- The occupancy and contents has been assumed to be limited combustible.
- It has been assumed that there are no unprotected vertical openings.
- Automatic sprinkler system will be designed and installed in accordance with NFPA 13. The water supply is standard for for both the system and fire department hose lines. The system will be fully supervised.

APPENDIX

D

WATER SYSTEM
CALCULATIONS &
MODELLING RESULT

210 CLEARVIEW - WATERGEMS MODEL OUTPUT

Hydraulic Model Properties

Title	210 Clearview - SPA Submittal Water Model
Engineer	Marina St. Marseille, EIT
Company	WSP Canada Inc.
Date	2024-08-23
Notes	

Scenario Summary

ID	1
Label	Average Day Demand
Notes	
Active Topology	Base Active Topology
User Data Extensions	Base User Data Extensions
Physical	Base Physical
Demand	Base Demand
Initial Settings	Base Initial Settings
Operational	Base Operational
Age	Base Age
Constituent	Base Constituent
Trace	Base Trace
Fire Flow	FUS
Energy Cost	Base Energy Cost
Pressure Dependent Demand	Base Pressure Dependent Demand
Transient	Base Transient
Failure History	Base Failure History
SCADA	Base SCADA
Steady State / EPS Solver Calculation Options	ADD
Transient Solver Calculation Options	Base Calculation Options

Hydraulic Summary

Time Analysis Type	Steady State	Simulation Start Date	2000-01-01
Friction Method	Hazen-Williams	Hydraulic Time Step	1.000
Accuracy	0.001	Duration	24.000
Trials	40	Calculation Type	Hydraulics Only

Junction Table - Time: 0.00 hours

ID	Label	Elevation (m)	Zone	Demand Collection	Demand (L/s)	Hydraulic Grade (m)
52	J-4	58.17	<None>	<Collection: 0 items>	0.00	109.90
32	J-1	58.30	<None>	<Collection: 1 item>	1.16	109.90
Pressure (psi)						
73						
73						

210 CLEARVIEW - WATERGEMS MODEL OUTPUT

Pipe Table - Time: 0.00 hours

ID	Label	Length (Scaled) (m)	Start Node	Stop Node	Diameter (mm)	Material
35	P-1	11	J-4	J-1	204.0	PVC
54	P-2(2)	10	J-4	J-1	204.0	PVC
53	P-2(1)	9	R-1	J-4	1,000.0	Ductile Iron
Hazen-Williams C	Has Check Valve?	Minor Loss Coefficient (Local)	Flow (L/s)	Velocity (m/s)	Headloss Gradient (m/m)	Has User Defined Length?
110.0	False	0.000	0.58	0.02	0.000	True
110.0	False	0.000	0.58	0.02	0.000	True
140.0	False	0.000	1.16	0.00	0.000	True
Length (User Defined) (m)						
7						
7						
1						

Reservoir Table - Time: 0.00 hours

ID	Label	Elevation (m)	Zone	Flow (Out net) (L/s)	Hydraulic Grade (m)
31	R-1	109.90	<None>	1.16	109.90

210 CLEARVIEW - WATERGEMS MODEL OUTPUT

Scenario Summary

ID	41
Label	Maximum Hour Demand
Notes	
Active Topology	Base Active Topology
User Data Extensions	Base User Data Extensions
Physical Demand	Peak Hour
Initial Settings	Base Initial Settings
Operational	Base Operational
Age	Base Age
Constituent	Base Constituent
Trace	Base Trace
Fire Flow	FUS
Energy Cost	Base Energy Cost
Pressure Dependent Demand	Base Pressure Dependent Demand
Transient	Base Transient
Failure History	Base Failure History
SCADA	Base SCADA
Steady State / EPS Solver Calculation Options	MHD
Transient Solver Calculation Options	Base Calculation Options

Hydraulic Summary

Time Analysis Type	Steady State	Simulation Start Date	2000-01-01
Friction Method	Hazen-Williams	Hydraulic Time Step	1.000
Accuracy	0.001	Duration	24.000
Trials	40	Calculation Type	Hydraulics Only

Junction Table - Time: 0.00 hours

ID	Label	Elevation (m)	Zone	Demand Collection	Demand (L/s)	Hydraulic Grade (m)
52	J-4	58.17	<None>	<Collection: 0 items>	0.00	109.90
32	J-1	58.30	<None>	<Collection: 1 item>	2.90	109.90
Pressure (psi)						
73						
73						

Pipe Table - Time: 0.00 hours

ID	Label	Length (Scaled) (m)	Start Node	Stop Node	Diameter (mm)	Material
35	P-1	11	J-4	J-1	204.0	PVC
54	P-2(2)	10	J-4	J-1	204.0	PVC

210 CLEARVIEW - WATERGEMS MODEL OUTPUT

Pipe Table - Time: 0.00 hours

ID	Label	Length (Scaled) (m)	Start Node	Stop Node	Diameter (mm)	Material
53	P-2(1)	9	R-1	J-4	1,000.0	PVC
Hazen-Williams C	Has Check Valve?	Minor Loss Coefficient (Local)	Flow (L/s)	Velocity (m/s)	Headloss Gradient (m/m)	Has User Defined Length?
110.0	False	0.000	1.46	0.04	0.000	True
110.0	False	0.000	1.44	0.04	0.000	True
140.0	False	0.000	2.90	0.00	0.000	True
Length (User Defined) (m)						
7						
7						
1						

Reservoir Table - Time: 0.00 hours

ID	Label	Elevation (m)	Zone	Flow (Out net) (L/s)	Hydraulic Grade (m)
31	R-1	109.90	<None>	2.90	109.90

210 CLEARVIEW - WATERGEMS MODEL OUTPUT

Scenario Summary

ID	47
Label	Max Day + Fire Flow (FUS)
Notes	
Active Topology	Base Active Topology
User Data Extensions	Base User Data Extensions
Physical	Max Day + FF
Demand	Max Day + FF
Initial Settings	Base Initial Settings
Operational	Base Operational
Age	Base Age
Constituent	Base Constituent
Trace	Base Trace
Fire Flow	FUS
Energy Cost	Base Energy Cost
Pressure Dependent Demand	Base Pressure Dependent Demand
Transient	Base Transient
Failure History	Base Failure History
SCADA	Base SCADA
Steady State / EPS Solver Calculation Options	MDD+FF
Transient Solver Calculation Options	Base Calculation Options

Hydraulic Summary

Time Analysis Type	Steady State	Simulation Start Date	2000-01-01
Friction Method	Hazen-Williams	Hydraulic Time Step	1.000
Accuracy	0.001	Duration	24.000
Trials	40	Calculation Type	Hydraulics Only

Junction Table - Time: 0.00 hours

ID	Label	Elevation (m)	Zone	Demand Collection	Demand (L/s)	Hydraulic Grade (m)
52	J-4	58.20	<None>	<Collection: 0 items>	0.00	109.90
32	J-1	58.30	<None>	<Collection: 1 item>	89.64	109.81
Pressure (psi)						
73						
73						

Pipe Table - Time: 0.00 hours

ID	Label	Length (Scaled) (m)	Start Node	Stop Node	Diameter (mm)	Material
35	P-1	11	J-4	J-1	204.0	PVC
54	P-2(2)	10	J-4	J-1	204.0	PVC

210 CLEARVIEW - WATERGEMS MODEL OUTPUT

Pipe Table - Time: 0.00 hours

ID	Label	Length (Scaled) (m)	Start Node	Stop Node	Diameter (mm)	Material
53	P-2(1)	9	R-1	J-4	1,000.0	Ductile Iron
Hazen-Williams C	Has Check Valve?	Minor Loss Coefficient (Local)	Flow (L/s)	Velocity (m/s)	Headloss Gradient (m/m)	Has User Defined Length?
110.0	False	0.000	45.10	1.38	0.013	True
110.0	False	0.000	44.54	1.36	0.013	True
140.0	False	0.000	89.64	0.11	0.000	True
Length (User Defined) (m)						
7						
7						
1						

Reservoir Table - Time: 0.00 hours

ID	Label	Elevation (m)	Zone	Flow (Out net) (L/s)	Hydraulic Grade (m)
31	R-1	109.90	<None>	89.64	109.90