

# SERVICING & STORMWATER MANAGEMENT REPORT MIXED USE DEVELOPMENT – 3030 ST JOSEPH BLVD



Project No.: CCO-24-0142

City File No.: D07-12-23-0090

Prepared for:

Theberge Developments Ltd.  
1600 Laperriere Ave Ottawa, ON K1Z 8P5

Prepared by:

Egis Canada Ltd. (Formerly McIntosh Perry Consulting Engineers Ltd.)  
115 Walgreen Road  
Carp, ON K0A 1L0

May 23, 2023

Rev: Sep 05, 2024

TABLE OF CONTENTS

1.0	PROJECT DESCRIPTION.....	1
1.1	<i>Purpose</i> .....	1
1.2	<i>Site Description</i> .....	1
1.3	<i>Proposed Development and Statistics</i> .....	2
1.4	<i>Existing Conditions and Infrastructure</i> .....	2
1.5	<i>Approvals</i> .....	3
2.0	BACKGROUND STUDIES.....	3
2.1	<i>Applicable Guidelines and Standards</i> .....	3
3.0	PRE-CONSULTATION SUMMARY.....	5
4.0	WATERMAIN.....	6
4.1	<i>Existing Watermain</i> .....	6
4.2	<i>Proposed Watermain</i> .....	6
5.0	SANITARY DESIGN.....	9
5.1	<i>Existing Sanitary Sewer</i> .....	9
5.2	<i>Proposed Sanitary Sewer</i> .....	9
5.3	<i>Proposed Sanitary Capacity</i> .....	10
6.0	STORM SEWER DESIGN.....	11
6.1	<i>Existing Storm Sewers</i> .....	11
6.2	<i>Proposed Storm Sewers</i> .....	11
7.0	PROPOSED STORMWATER MANAGEMENT.....	12
7.1	<i>Design Criteria and Methodology</i> .....	12
7.2	<i>Runoff Calculations</i> .....	12
7.3	<i>Pre-Development Drainage</i> .....	13
7.4	<i>Post-Development Drainage</i> .....	13
7.5	<i>Quality Control</i> .....	14
8.0	EROSION AND SEDIMENT CONTROL.....	15
8.1	<i>Temporary Measures</i> .....	15
8.2	<i>Permanent Measures</i> .....	15
9.0	SUMMARY.....	17
10.0	RECOMMENDATION.....	18
11.0	STATEMENT OF LIMITATIONS.....	19

## LIST OF TABLES

Table 1: Water Demands.....	7
Table 2: Fire Protection Confirmation.....	7
Table 3: Boundary Condition Results.....	8
Table 4: Sanitary Design Criteria.....	10
Table 5: Summary of Estimated Sanitary Flow.....	10
Table 6: Pre-Development Runoff Summary.....	13
Table 7: Post-Development Runoff Summary.....	13

## APPENDICES

Appendix A: Site Location Plan

Appendix B: City of Ottawa Pre-Consultation Notes

Appendix C: Watermain Calculations

Appendix D: Sanitary Calculations

Appendix E: Pre-Development Drainage Plan

Appendix F: Post-Development Drainage Plan

Appendix G: Stormwater Management Calculations

Appendix H: City of Ottawa Design Checklist

## 1.0 PROJECT DESCRIPTION

### 1.1 Purpose

Egis (formerly McIntosh Perry) has been retained by Theberge Developments Ltd. to prepare this Servicing and Stormwater Management Report in support of the Site Plan Control process for the proposed mixed-use development, located at 3030 St Joseph Boulevard within the City of Ottawa.

The main purpose of this report is to present a servicing design for the development in accordance with the recommendations and guidelines provided by the City of Ottawa (City), the Rideau Valley Conservation Authority (RVCA), and the Ministry of the Environment, Conservation and Parks (MECP). This report will address the water, sanitary and storm sewer servicing for the development, ensuring that existing and available services will adequately service the proposed development.

This report should be read in conjunction with the following drawings:

- CCO-24-0142, C101 – Site Grading and Drainage Plan,
- CCO-24-0142, C102 – Site Servicing Plan,
- CCO-24-0142, PRE – Pre-Development Drainage Area Plan (*Appendix E*), and
- CCO-24-0142, POST – Post-Development Drainage Area Plan (*Appendix F*)

### 1.2 Site Description



Figure 1: Site Map

The subject property, herein referred to as the site, is located 3030 St Joseph Boulevard within the Orleans East-Cumberland ward. It is described as Part 1 Plan of Part of Lots 1,2,3 and 4, Registered



Plan 17, City of Ottawa. The land in question covers approximately *0.26 ha* and is located between St Joseph Boulevard and Duford Drive. See the Site Location Plan in *Appendix A* for more details.

### 1.3 Proposed Development and Statistics

The proposed development consists of an 18 -storey mixed-use residential building. Site access will be provided via a drive aisle extending from St Joseph Boulevard with underground parking provided for residents and visitors. Refer to the Site Plan prepared by RLA Architecture included in *Appendix B* for details.

### 1.4 Existing Conditions and Infrastructure

The existing site is currently undeveloped and is not serviced by any sanitary or water services. There is an existing 254mm diameter cast iron and 305mm diameter PVC municipal watermain which traverse the site from Duford to St. Joseph. There is also an existing 450mm diameter concrete municipal sanitary which traverses the site from Duford to St. Joseph. Storm servicing for the site is provided via municipal catch basins within Duford Drive and St Joseph Boulevard.

Sewer and watermain mapping collected from the City of Ottawa indicate that the following services exist across the property frontages within the adjacent municipal rights-of-way(s):

- St Joseph Boulevard
  - 305 mm diameter cast iron watermain,
  - 305 mm diameter PVC watermain,
  - 406 mm diameter ductile iron watermain
  - 610 mm C01 Watermain
  - 250 mm diameter and 450 mm diameter concrete sanitary sewer tributary to the Cumberland Collector, and a
  - 675-750 mm diameter concrete storm sewer tributary to Taylor Creek approximately 0.4 km downstream.
- Duford Drive
  - 254mm diameter cast iron watermain,
  - 450 mm concrete sanitary sewer tributary to the Cumberland Collector, and a
  - 600 mm diameter concrete storm sewer tributary to Taylor Creek approximately 0.50 km downstream.

## 1.5 Approvals

The proposed development is subject to the City of Ottawa site plan control approval process. Site plan control requires the City to review, provided concurrence and approve the engineering design package. Permits to construct can be requested once the City has issued a site plan agreement.

An Environmental Compliance Approval (ECA) through the Ministry of Environment, Conservation and Parks (MECP) is not anticipated to be required for the development since the development is contained within a single parcel of land, is not within a combined sewershed, and does not propose industrial sewage. As a result, the stormwater management system meets the exemption requirements under O.Reg 525/90.

## 2.0 BACKGROUND STUDIES

Background studies that have been completed for the proposed site include City of Ottawa as-built drawings, and a topographical survey.

As-built drawings of existing services within the vicinity of the proposed site were reviewed in order to determine accurate servicing and stormwater management schemes for the site.

A topographic survey of the site was completed by Annis, O'Sullivan, Vollebakk Ltd.

### 2.1 Applicable Guidelines and Standards

City of Ottawa:

- ◆ Ottawa Sewer Design Guidelines, City of Ottawa, SDG002, October 2012. (*Ottawa Sewer Guidelines*)
  - Technical Bulletin ISTB-2014-01 City of Ottawa, February 2014. (*ISTB-2014-01*)
  - Technical Bulletin PIEDTB-2016-01 City of Ottawa, September 2016. (*PIEDTB-2016-01*)
  - Technical Bulletin ISTB-2018-01 City of Ottawa, January 2018. (*ISTB-2018-01*)
  - Technical Bulletin ISTB-2018-03 City of Ottawa, March 2018. (*ISTB-2018-03*)
  - Technical Bulletin ISTB-2019-01 City of Ottawa, January 2019. (*ISTB-2019-01*)
  - Technical Bulletin ISTB-2019-02 City of Ottawa, February 2019. (*ISTB-2019-02*)
- ◆ Ottawa Design Guidelines – Water Distribution City of Ottawa, July 2010. (*Ottawa Water Guidelines*)
  - Technical Bulletin ISD-2010-2 City of Ottawa, December 15, 2010. (*ISD-2010-2*)
  - Technical Bulletin ISDTB-2014-02 City of Ottawa, May 2014. (*ISDTB-2014-02*)
  - Technical Bulletin ISTB-2018-02 City of Ottawa, March 2018. (*ISTB-2018-02*)

Ministry of Environment, Conservation and Parks:

- ◆ Stormwater Planning and Design Manual, Ministry of the Environment, March 2003. (*MECP Stormwater Design Manual*)

- ◆ Design Guidelines for Sewage Works, Ministry of the Environment, 2008. (*MECP Sewer Design Guidelines*)

Other:

- ◆ Water Supply for Public Fire Protection, Fire Underwriters Survey, 2020. (*FUS Guidelines*)

### 3.0 PRE-CONSULTATION SUMMARY

A pre-consultation meeting was conducted on March 23, 2023 regarding the proposed site. Specific design parameters to be incorporated within this design include the following:

- Post-development 100-year storm to be restricted to pre-development 5-year storm.
- The allowable release rate is to be computed using the lesser of  $C=0.5$  or existing.
- Quality control as per RVCA requirements

The notes from the City of Ottawa can be found in *Appendix B*.

## 4.0 WATERMAIN

### 4.1 Existing Watermain

The site is located within the 2E pressure zone, as per the Water Distribution System Mapping included in *Appendix C*. There are existing, 406mm ductile iron and 610mm C01 watermains within St Joseph Boulevard. There is an existing 254 cast iron - 305mm PVC watermain which extends through the site into Duford Drive. There are three public hydrants located on St Joseph Boulevard available to provide fire flow to the development.

There are currently no existing private water services within the site.

### 4.2 Watermain Relocation

The existing 254 cast iron – 305mm PVC watermain currently located within the site is to be relocated around the site prior to the construction of the development. The proposed watermain will be extend around the site within the Duford Drive ROW before connecting back to the existing watermain 610mm C01 watermain within St. Joseph Boulevard. Refer to plans *C102*, *C201*, *C202*, and *C203* for detailed servicing layouts.

### 4.3 Proposed Watermain

Dual 150mm diameter PVC water services are proposed to service the development complete with water valves located at the property line. The water services are proposed to be serviced by the existing 406 mm diameter ductile iron watermain within St Joseph Boulevard. The services are designed to have a minimum of 2.4m cover. Refer to drawing *C102* for a detailed servicing layout.

The Fire Underwriters Survey 2020 (FUS) method was utilized to determine the required fire flow for the site. The 'C' factor (type of construction) for the FUS calculation was determined to be 0.8 (non-combustible construction). The total effective floor area ('A' value) for the FUS calculation was determined to be  $3,309 m^2$ . The results of the calculations yielded a required fire flow of  $5,000 L/min$ . The detailed calculations for the FUS and can be found in *Appendix C*.

The water demands for the proposed building have been calculated to adhere to the *Ottawa Design Guidelines – Water Distribution* manual and can be found in *Appendix C*. The results have been summarized below. In accordance with Section 4.3.1 of the guidelines, service areas with a basic day demand greater than  $50 m^3/day$  require a dual connection to the municipal system. The basic day demand for the development is estimated to be  $103 m^3/day$ , therefore a dual connection is required.

Table 1: Water Demands

Site Area	0.26ha
Residential	280 L/c/day
Commercial	28,000 L/ha/day
Average Day Demand (L/s)	1.08
Maximum Daily Demand (L/s)	3.60
Peak Hourly Demand (L/s)	5.41
FUS Fire Flow Requirement (L/s)	83.33

To confirm the adequacy of fire flow to protect the proposed development, public fire hydrants within 150 m of the proposed building were reviewed per City of Ottawa *ISTB 2018-02* Appendix I Table 1. Based on City guidelines (*ISTB-2018-02*), the existing hydrants can provide adequate fire coverage to the proposed development. The results are summarized below.

Table 2: Fire Protection Confirmation

Building	Fire Flow Demand (L/min.)	Fire Hydrant(s) within 75m*	Fire Hydrant(s) within 150m*	Combined Fire Flow (L/min.)
Proposed Building	5,000 (FUS)	1	2	13,000

\*Fire hydrants within 75 metres contribute 5,700 L/min to fire flow and fire hydrants within 150 meters contribute 3,800 L/min to fire flow, respectively, per *ISTB-2018-02*.

The City provided the estimated water pressures at both for the average day scenario, peak hour scenario and the max day plus fire flow scenario for the demands indicated by the correspondence in *Appendix C*. The resulting pressures for the boundary conditions results are shown in *Table 3*, below.



Table 3: Boundary Condition Results

Scenario	Proposed Demands (L/s)	Connection 1 HGL (m H <sub>2</sub> O)* /kPa
Average Day Demand	1.08	44.7 / 438.5
Maximum Daily + Fire Flow Demand	86.93	41.8 / 410.1
Peak Hourly Demand	5.41	40.0 / 392.4
*Adjusted for an estimated ground elevation of 69.4m above the connection point.		

The normal operating pressure range is anticipated to be 392 kPa to 439 kPa and will not be less than 275 kPa (40 psi) or exceed 689 kPa (100 psi). The proposed watermains will meet the minimum required 20 psi (140 kPa) from the *Ottawa Water Guidelines* at the ground level under maximum day demand and fire flow conditions. A pressure reducing valve is not anticipated to be required since the pressures do not exceed 552 kPa (80 psi) in the average day scenario.

## 5.0 SANITARY DESIGN

### 5.1 Existing Sanitary Sewer

There is an existing 250 mm diameter and 450 mm diameter Concrete sanitary sewer within St Joseph Boulevard, tributary to the Cumberland Collector. There is an existing 450mm concrete sanitary that sewer extends through the site from Duford Drive. Refer to the City of Ottawa Trunk Sewer Map figure available in *Appendix D*.

### 5.2 Sanitary Sewer Realignment

The existing 450mm diameter concrete sanitary sewer, which is routed through the site, is to be realigned from MHS353869 to MHS4436, to allow for the construction of the proposed building.

As shown on plan *C102* a maintenance structure (*MH2A*) is proposed to tie into the existing sewer just downstream of MHS35869. The proposed alignment will route the sewer outside of the property within the Duford Drive before tying back into the existing 450mm diameter sewer at *MH2E* just downstream of existing MHS4436. Refer to plan *C102*.

The contractor will be required to submit a formal construction phasing and flow management plan to both Egis and the City inspector for approval prior to commencement of construction.

#### 5.2.1 Pipe Capacity

The approximate capacity of the existing 450mm sewer downstream of MHS4436 is 119 L/s. As demonstrated on the *Sanitary Sewer Design Relocation Sheet* in *Appendix D* the capacity of the realigned 450mm diameter sewer network from *MH2A* to *MH2E* is 495 L/s. Therefore, capacity of the realigned network exceeds that of the existing immediate downstream network. Due to the complexity of the further downstream network, the City will need to advise of any downstream constraints.

### 5.3 Proposed Sanitary Sewer

A new 200 mm diameter gravity sanitary service is proposed to be connected to the existing 250 mm diameter sanitary sewer within St Joseph Boulevard. The sanitary service will be complete with a maintenance hole (*MH1A*) which will be installed at the property line as per the *City of Ottawa – Sewer Design Guidelines*.

The proposed development consists of a mixed-use residential building. The peak design flows for the proposed buildings were calculated using criteria from the Ottawa Sewer Guidelines and are summarized in *Table 4*, below.

Table 4: Sanitary Design Criteria

Design Parameter	Value
Site Area	0.26 ha
Residential Demand	280 L/c/d
Residential Peaking Factor	3.45
Commercial/Amenity	2,800 L/(1000m <sup>2</sup> /d )
Institutional Peaking Factor	1.0
Extraneous Flow Allowance	0.33 L/s/ha

Based on the unit occupancy statistics provided by the architect, the proposed site development will generate a flow of 4.29 L/s. Table 5 below, summarizes the estimated wastewater flow from the proposed development. Refer to *Appendix D* for detailed calculations.

Table 5: Summary of Estimated Sanitary Flow

Design Parameter	Total Flow (L/s)
Total Estimated Average Dry Weather Flow	1.17
Total Estimated Peak Dry Weather Flow	3.80
Total Estimated Peak Wet Weather Flow	3.88

#### 5.4 Proposed Sanitary Capacity

The proposed sanitary network has been designed to attain a minimum full flow target velocity (cleansing velocity) of 0.6 m/s and a full flow velocity of not more than 3.0 m/s. The capacity of the proposed 200 mm diameter sanitary service with a slope of 1.00% is 34.22 L/s based on sanitary sewer design calculations available in *Appendix D*.

Due to the complexity of the downstream network, the City will need to advise of any downstream constraints.

## 6.0 STORM SEWER DESIGN

### 6.1 Existing Storm Sewers

Water runoff from the site is currently tributary to Taylor Creek within the Ottawa River East Subwatershed. Storm servicing for the site is currently provided via municipal catchbasins within St Joseph Boulevard and Duford Drive.

There is an existing 600mm diameter concrete sewer within Duford Drive. There is also a 675mm diameter concrete sewer within St Joseph Boulevard. Drainage collected from the existing storm sewers is tributary to Taylor Creek approximately 0.5 km downstream and ultimately the Ottawa River.

### 6.2 Proposed Storm Sewers

A new 200mm diameter storm service is proposed to be extended from the existing 600mm diameter storm sewer within Duford Drive. The sewer system will provide attenuation for the roof area and at grade walkway area east of the building by an internal cistern complete with a flow attenuation device to be specified by the mechanical engineer.

Runoff from the landscaped area south of the building will be directed to a catchbasin complete with a Tempest LMF40 ICD to provide attenuation. Attenuated flow will discharge to the existing 600mm diameter storm sewer via a 250mm diameter catchbasin lead.

See drawing *C102* for a detailed servicing layout and *CCO-23-1150 - POST* included in *Appendix 'F'* of this report for more details. The Stormwater Management design for the subject property will be outlined in *Section 7.0* of this report.

## 7.0 PROPOSED STORMWATER MANAGEMENT

### 7.1 Design Criteria and Methodology

Stormwater management for the proposed site will be maintained through two methods. The first will store and control runoff collected from the roof of the proposed building and the at-grade walkway area within the site. The second will control stormwater via a subsurface storage tank and will collect runoff from the at-grade area to the south of the site. Flow will be directed to a catch basin complete with an ICD for attenuation before discharging to the existing 600mm diameter concrete storm sewer within Duford Drive.

In summary, the following design criteria have been employed in developing the stormwater management design for the site as directed by the RVCA and City:

#### Quality Control

- Due to the site proximity to the outlet runoff must be designed to achieve an 80% total suspended solids removal (*enhanced* level).

#### Quantity Control

- Pre-development time of concentration (TC) shall be calculated and be no less than 10minutes. Post development runoff shall be calculated with a TC of 10 minutes.
- Control site post-development flows to the 5-year pre-development flows with a calculated C value no greater than 0.50.

### 7.2 Runoff Calculations

Runoff calculations presented in this report are derived using the Rational Method, given as:

$$Q = 2.78CIA \text{ (L/s)}$$

Where	C	= Runoff coefficient
	I	= Rainfall intensity in mm/hr (City of Ottawa IDF curves)
	A	= Drainage area in hectares

It is recognized that the Rational Method tends to overestimate runoff rates. As a result, the conservative calculation of runoff ensures that any SWM facility sized using this method is expected to function as intended.

The following coefficients were used to develop an average C for each area:

Roofs/Concrete/Asphalt	0.90
Gravel	0.60
Undeveloped and Grass	0.20

As per the *City of Ottawa - Sewer Design Guidelines*, the average 'C' value must be increased by 25% for a 100-year storm event to a maximum of 1.0.

### 7.3 Pre-Development Drainage

It has been assumed that the site contains no stormwater management controls for flow attenuation. The estimated pre-development peak flows for the 5, and 100-year events are summarized below in *Table 6*. See CCO-24-0142 - *PRE* in *Appendix E* and *Appendix G* for calculations.

Table 6: Pre-Development Runoff Summary

Drainage Area	Area (ha)	Q (L/s)	
		5-Year	100-Year
A1	0.264	15.31	32.79
Total	0.264	15.31	32.79

See *Appendix E* for an existing conditions drainage plan and *Appendix G* for calculations.

### 7.4 Post-Development Drainage

The proposed site drainage limits are demonstrated on the Post-Development Drainage Area Plan. See CCO-24-0142 - *POST* in *Appendix F* of this report for more details. A summary of the Post-Development Runoff Calculations can be found below.

Table 7: Post-Development Runoff Summary

Drainage Area	Area (ha)	5-Year Peak Flow (L/s)	100-Year Peak Flow (L/s)	100-Year Storage Requirement (m <sup>3</sup> )	100-Year Storage Available (m <sup>3</sup> )
B1	0.179	1.26	2.40	102.3	102.3
B2	0.057	1.10	1.30	5.7	13.0
B3	0.028	6.04	11.58		
Total	0.264	8.40	15.28	107.92	115.26



Runoff for Area B1 will be collected by roof drains (uncontrolled) and a trench drain (*TD1*) before being conveyed to the internal cistern. The  $102.3\text{ m}^3$  internal cistern is anticipated to direct stormwater to the outlet at a maximum flow rate of  $1.26\text{ L/s}$  and  $2.40\text{ L/s}$  for the 5 and 100-year storms, respectively. Flows in excess of the 100-year storm will need to be directed towards Duford Street via a cistern overflow. A flow attenuation device is to be specified by the Mechanical Engineer.

Runoff for Area B2 will be collected by catch basins (*CB1 & LCB2*) complete with a Tempest LMF 40 ICD which will provide attenuation. Runoff storage for area B2 will be provided by a Triton S-29B storage tank (or approved equivalent). Refer to *Appendix G* for detailed storage tank drawings. Runoff will be restricted to maximum flow rate of  $1.10\text{ L/s}$  and  $1.30\text{ L/s}$  for the 5 and 100-year storms, respectively, with up to  $13.0\text{ m}^3$  of tank storage.

Runoff for Area B3 will be directed to the St Joseph Boulevard right of way without attenuation and will be compensated for in areas with attenuation.

## 7.5 Quality Control

The following methods will be utilized to provide quality controls for the site:

- Quality controls for Area B1 will be provided via the cistern in a settling pit. No surface parking or drive aisles are proposed within this area. Runoff from at grade areas will combine with clean roof drainage before discharging to the city sewer. Cistern details are to be provided by the mechanical engineer.
- Area B2 will collect runoff from landscaped areas and therefore drainage is considered clean.

## 8.0 EROSION AND SEDIMENT CONTROL

### 8.1 Temporary Measures

Before construction begins, temporary silt fence, straw bale or rock flow check dams will be installed at all natural runoff outlets from the property. It is crucial that these controls be maintained throughout construction and inspection of sediment and erosion control will be facilitated by the Contractor or Contract Administration staff throughout the construction period.

Silt fences will be installed where shown on the final engineering plans, specifically along the downstream property limits. The Contractor, at their discretion or at the instruction of the City, Conservation Authority or the Contract Administrator shall increase the quantity of sediment and erosion controls on-site to ensure that the site is operating as intended and no additional sediment finds its way off site. The rock flow, straw bale & silt fence check dams and barriers shall be inspected weekly and after rainfall events. Care shall be taken to properly remove sediment from the fences and check dams as required. Fibre roll barriers are to be installed at all existing curb inlet catchbasins and filter fabric is to be placed under the grates of all existing catchbasins and manholes along the frontage of the site and any new structures immediately upon installation. The measures for the existing/proposed structures is to be removed only after all areas have been paved. Care shall be taken at the removal stage to ensure that any silt that has accumulated is properly handled and disposed of. Removal of silt fences without prior removal of the sediments shall not be permitted.

Although not anticipated, work through winter months shall be closely monitored for erosion along sloped areas. Should erosion be noted, the Contractor shall be alerted and shall take all necessary steps to rectify the situation. Should the Contractor's efforts fail at remediating the eroded areas, the Contractor shall contact the City and/or Conservation Authority to review the site conditions and determine the appropriate course of action. As the ground begins to thaw, the Contractor shall place silt fencing at all required locations as soon as ground conditions warrant. Please see the *Site Grading, Drainage and Sediment & Erosion Control Plan* for additional details regarding the temporary measures to be installed and their appropriate OPSD references.

### 8.2 Permanent Measures

Rip-rap will be placed at all locations that have the potential for concentrated flow. It is crucial that the Contractor ensure that the geotextile is keyed in properly to ensure runoff does not undermine the rip rapped area. Additional rip rap is to be placed at erosion prone locations as identified by the Contractor / Contract Administrator / City or Conservation Authority.

It is expected that the Contractor will promptly ensure that all disturbed areas receive topsoil and seed/sod and that grass be established as soon as possible. Any areas of excess fill shall be removed or levelled as soon as possible and must be located a sufficient distance from any watercourse to ensure that no sediment is washed out into the watercourse. As the vegetation growth within the

site provides a key component to the control of sediment for the site, it must be properly maintained once established. Once the construction is complete, it will be up to the landowner to maintain the vegetation and ensure that the vegetation is not overgrown or impeded by foreign objects.

## 9.0 SUMMARY

- A new mixed-use residential building is proposed to be constructed at 3030 St Joseph Boulevard.
- Dual 150 mm diameter water services are proposed to be connected to the existing 406 mm diameter watermain within St Joseph Boulevard.
- A new 200 mm diameter sanitary service complete with a maintenance hole at the property line is proposed to service the development, extending from the existing 250 mm diameter sanitary sewer within St Joseph Boulevard.
- A new 200mm storm service for rooftop, surface, and foundation drainage is proposed to service the development. The storm service will connect to the 600 mm diameter storm sewer within Duford Drive.
- A new 200 mm storm service is proposed to convey drainage from the landscaped south of the building to the existing 600 mm diameter storm sewer within Duford Drive.
- Storage for the 5- through 100-year storm events will be provided through an internal cistern and a sub-surface storage system.
- Quality control is proposed to be provided via the cistern settling pit.

## 10.0 RECOMMENDATION

Based on the information presented in this report, we recommend that City of Ottawa approve this Servicing and Stormwater Management Report in support of the proposed mixed-use residential development at 3030 St Joseph Boulevard.

This report is respectfully being submitted for approval.

Regards,

Egis Canada Ltd.



Andrew MacLeod, P.Eng.  
Senior Engineer  
T: 365.527.2696  
E: Andrew.MACLEOD@egis-group.com

Ryan Robineau  
Project Coordinator  
T: 613.714.6611  
E: Ryan.ROBINEAU@egis-group.com

## 11.0 STATEMENT OF LIMITATIONS

This report was produced for the exclusive use of Theberge Developments Ltd. The purpose of the report is to assess the existing stormwater management system and provide recommendations and designs for the post-construction scenario that are in compliance with the guidelines and standards from the Ministry of the Environment, Conservation and Parks, City of Ottawa and local approval agencies. Egis reviewed the site information and background documents listed in Section 2.0 of this report. While the previous data was reviewed by Egis and site visits were performed, no field verification/measures of any information were conducted.

Any use of this review by a third party, or any reliance on decisions made based on it, without a reliance report is the responsibility of such third parties. Egis accepts no responsibility for damages, if any, suffered by any third party as a result of decisions or actions made based on this review.

The findings, conclusions and/or recommendations of this report are only valid as of the date of this report. No assurance is made regarding any changes in conditions subsequent to this date. If additional information is discovered or becomes available at a future date, Egis should be requested to re-evaluate the conclusions presented in this report, and provide amendments, if required.



APPENDIX A  
KEY PLAN

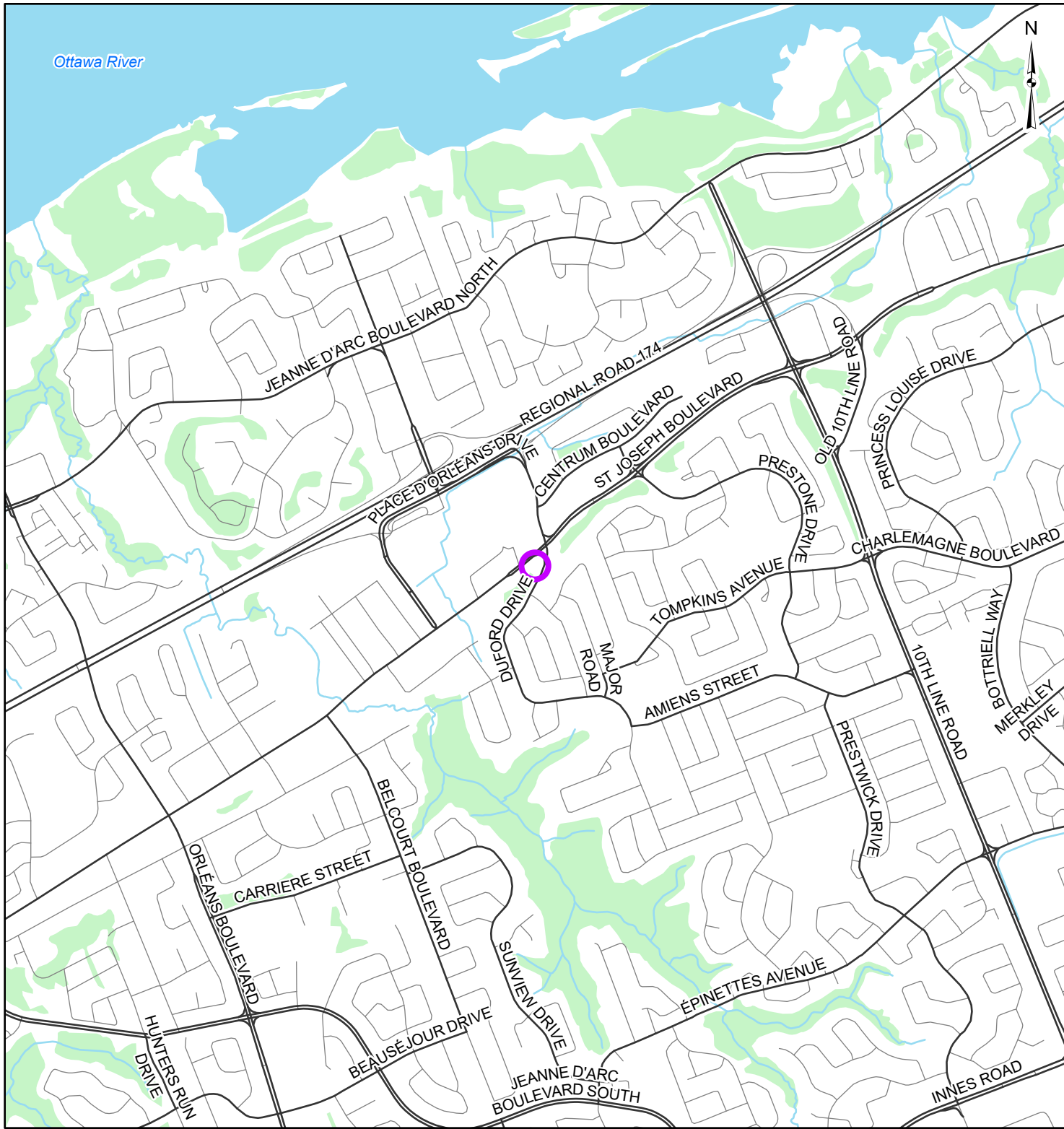

Ottawa River

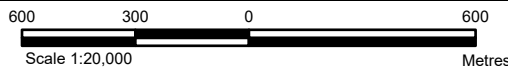

**LEGEND**

- Site Location
- Watercourse
- Local Road
- Waterbody
- Major Road
- Wooded Area

**REFERENCE**

GIS data provided by the Ontario Ministry of Natural Resources and Forestry, 2023.

CLIENT:		<b>THEBERGE HOMES</b>	
PROJECT:		<b>3030 ST. JOSEPH BOULEVARD</b>	
TITLE:		<b>SITE LOCATION</b>	
PROJECT NO: CCO-24-0142		FIGURE:	
Date	Apr., 27, 2023	<b>1</b>	
GIS	AH		
Checked By	RR		

**McINTOSH PERRY**  
 115 Walgreen Road, RR3, Carp, ON K0A1L0  
 Tel: 613-836-2184 Fax: 613-836-3742  
 www.mcintoshperry.com

C:\Users\stjames@mcintosh\_perry\GIS - Documents\Projects\2024\CCO-24-0142\_Theberge - 3030 St. Joseph Blvd\aprx\Key Maps\LandDevelopment\CCO-24-0142\_SiteLocation.aprx

APPENDIX B  
BACKGROUND DOCUMENTS

---

From: Belan, Steve <[Steve.Belan@ottawa.ca](mailto:Steve.Belan@ottawa.ca)>  
Sent: Thursday, May 4, 2023 4:00 PM  
To: Scott Alain <[alain@fotenn.com](mailto:alain@fotenn.com)>; Tamara Nahal <[nahal@fotenn.com](mailto:nahal@fotenn.com)>  
Cc: Belan, Steve <[Steve.Belan@ottawa.ca](mailto:Steve.Belan@ottawa.ca)>; Jeremy Silburt <[jeremy@thebergehomes.com](mailto:jeremy@thebergehomes.com)>; Joey Theberge <[joeytheberge@thebergehomes.com](mailto:joeytheberge@thebergehomes.com)>; Giles, Peter <[peter.giles1@ottawa.ca](mailto:peter.giles1@ottawa.ca)>; Hassan, Selma <[Selma.Hassan@ottawa.ca](mailto:Selma.Hassan@ottawa.ca)>; Polyak, Alex <[alex.polyak@ottawa.ca](mailto:alex.polyak@ottawa.ca)>; McMahon, Patrick <[patrick.mcmahon@ottawa.ca](mailto:patrick.mcmahon@ottawa.ca)>; Wildman, Geraldine <[Geraldine.Wildman@ottawa.ca](mailto:Geraldine.Wildman@ottawa.ca)>  
Subject: FW: Pre-con Follow-up - 3030 St Joseph - Zoning, OPA and Site Plan

**CAUTION: This email is from an external sender. Do not click links or open attachments unless you recognize the sender and know the content is safe.**

Scott and Tamara,

Please refer to the below and/or attached notes regarding the Pre-Application Consultation (pre-con) Meeting held on Wednesday March 22, 2023 for the property at 1887 St. Joseph Blvd for a Rezoning Application in anticipation of selling the property to a developer to construct building complex consisting mid and modest high-rise residential buildings with a private street and POP. I have also attached the required Plans & Study List for application submission.

Below or attached are staff's preliminary comments based on the information available at the time of pre-con meeting:

### **Planning**

- Policies and provisions
  - The New Official Plan has designated the subject property as Hub, Evolving Neighbourhood and on a Major Collector and is in close proximity with the Place de Orleans Light Rail station. The secondary plan has recently been approved and been appealed and set out a similar development scenario for the site.
- The Official Plan Amendment will address policy concerns related to the ambiguity within the Official Plan pertaining to this site and the proposed development.
- Zoning will be specific to the proposed development on this site and a schedule will be employee to implement the building's terracing. A (-h) Hold Provision will be placed on the site until there is an approved Site Plan and an agreement to relocate the existing sewer which crosses the property.
- Community benefits vs. the Section 37
  - The previous Zoning By-law Amendment required a Section 37 agreement be executed..
  - "Community Benefits Charge", [By-law No. 2022-307](#), of 4% of the land value. This charge will be required for ALL buildings that are 5 or more storeys and 10 or more units and will be required at the time of building permit. Questions regarding this change can be directed to [Ranbir.Singh@ottawa.ca](mailto:Ranbir.Singh@ottawa.ca).
  - Two ways to approach this: the previous Section 37 agreement can be amended to include the up-lift of the 2 additional storeys, with an exemption from paying the CBC. Or, we remove the current agreement and charge the entire CBC towards the development as assessed at the time of site plan approval and paid at the time of the Building permit.
- I have concerns that these application will stir up a similar response within the community as the original application made.
- For Zoning By-law Amendments the Applicant must now provide a proposed strategy for public consultation as directed by Bill 73

## Urban Design

### **UDRP, Design Guidelines, Design Brief and Analyses**

1. The site is subject to UDRP review. Given the question of height has been essentially determined via the SP and Zoning, the applicant can likely expect Panel attention focused on the building design, relationship to adjacent uses and to the public realm.
2. The City's Urban Design Guidelines for Highrise Buildings are applicable to the site. Given the UDRP review, the applicant should pay particular attention to these guidelines and be able to indicate how the design responds to these.
3. A Design Brief is required. A Terms of Reference for the Design Brief is attached; all elements highlighted in yellow must be addressed in written and / or graphic format in the Design Brief. Given the sloped site, the Design Brief needs to include a number of clear site sections that illustrate how the building is designed in consideration of the topography.
4. Shadow and Wind Analysis are required. The Terms of Reference for these are attached.
5. The Site and Landscape Plans need to clearly show:
  - a. The footprint of the underground parking
  - b. The location of all street lights, hydro poles and wires

### **Public Realm**

6. The site is subject to the Orleans Corridor Study. This Study includes cross-sections for the evolution of the St. Joseph Blvd. ROW; these are shown in Annex B. The cross-section applicable to this site is shown below.

The proposed building setback makes it difficult to meet the vision for the ROW in the short to medium term. If the future sidewalk is built as part of this proposal, there is no soft surface area for street tree planting, until the ultimate ROW design is implemented. This is show on the first slide of the attached PDF "3030 St. Joseph frontage design". However, if the future sidewalk location is delayed and instead trees are planted, these trees will all have to be ripped out when the ultimate ROW is built.

The second slid of the PDF "3030 St. Joseph frontage design" illustrates a proposal that would see a slight deviation from the ROW design, but that meets the spirit of the design and allows street trees to be planted now that would remain in place through the ultimate ROW design. It would create a present and future condition that would enhance both the public realm and frontage of the building.

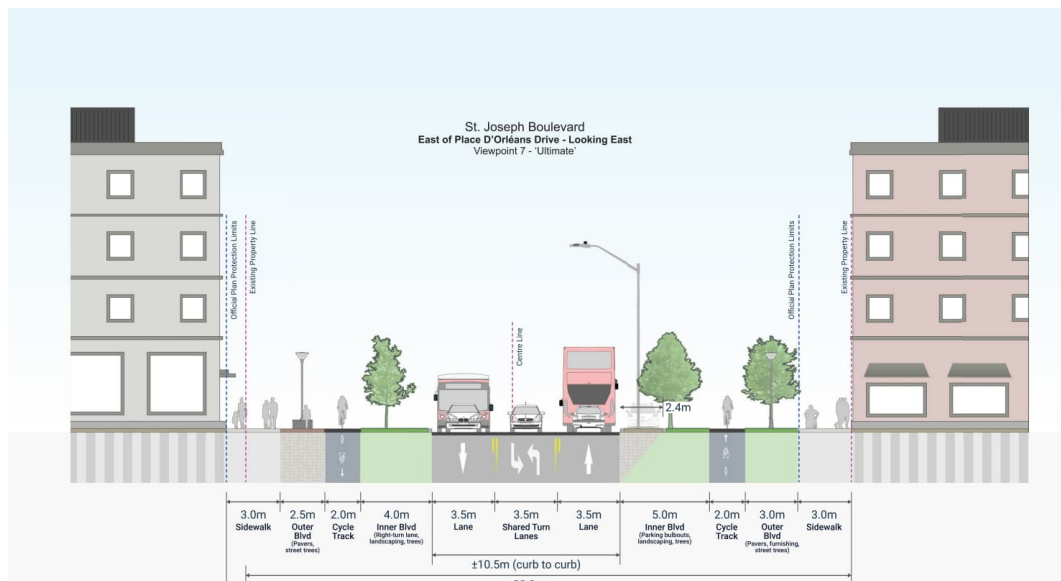

7. At the corner of St. Joseph and Duford, as well as going up the hill, the ROW design is predominantly hard surface and includes stairs and retaining walls. Urban Design has concerns with this. To help achieve OP goals policies related to the urban tree canopy and urban heat island, the area between the sidewalk and the property line should be soft surface and include street trees (planted 8 – 10m o/c depending on species).
8. As the applicant designs the amenity area / POPS on their site, special attention needs to be paid to ensuring clear site lines of all spaces so that no CEPTED concerns are raised.
9. Any elements that remain in the ROW (planter boxes, stairs, ramps, retaining walls etc.) will require a permanent encroachment agreement with the City . The encroachment agreement has required annual fees included on the Tax roll. The Site Plan Control agreement must include a condition related to the requirement for the encroachment agreement.
10. Similarly, a Maintenance and Liability Agreement (MLA) will also be required, in perpetuity, for any stairs, retaining walls, pavers etc. that remain in the ROW. The property owner will be responsible for repairs, snow clearing etc. The agreement must be registered on title. The Site Plan Control agreement must include a condition related to the requirement for the MLA.

Feel free to contact the Urban Design Planner, Selma Hassan, at [selma.hassan@ottawa.caa](mailto:selma.hassan@ottawa.caa), for follow-up questions.

**Engineering**

**Site Plan Requirements**

Required:

Water Boundary condition requests must include the location of the service and the expected loads required by the proposed development. Please provide the following information:

- Location of service connections (MAP provided)
- Type of development and the amount of fire flow required (as per FUS).



- Average daily demand: \_\_\_\_ l/s.
- Maximum daily demand: \_\_\_\_ l/s.
- Maximum hourly daily demand: \_\_\_\_ l/s.

### **Submission Documents:**

- Site Plan
- Topographical Plan of Survey Plan with a published Bench Mark
- Removals Plan
- Grading & Drainage Plan
- General Plan of Services
- Erosion & Sediment Control Plan
- Design Brief and Stormwater Management Report
- Geotechnical Report including a slope stability analysis

### **Design Criteria - Civil Engineer to contact me directly**

- Suggest to prepare a concept servicing plan and share it with the City for comment prior to a detailed submission.
- Stormwater Management requires runoff detention on site:
  - Post 100 year to Pre 5 year
- The allowable release rate is to be computed using the lesser of C=0.5 or existing.
- Consider pedestrian Accessibilities at max 5%.
- Quality control as per Rideau Valley Conservation Authority Requirements.
- Permissible ponding of 350mm for 100-year. No spilling to adjacent sites.
- At 100-year ponding elevation you must spill to the ROW.
- 100-year Spill elevation must be 300mm lower than any building opening or ramp.

### **Minimum Drawing and File Requirements- All Plans**

- Plans are to be submitted on standard **A1 size** (594mm x 841mm) sheets, utilizing an appropriate Metric scale (1:200, 1:250, 1:300, 1:400, or 1:500).
- With all submitted hard copies provide individual PDF of the DWGs and for reports please provide one PDF file of the reports. **All PDF documents are to be unlocked and flattened.**

Feel free to contact the Infrastructure Project Manager, Alex Polyak, at [Alex.Polyak@ottawa.ca](mailto:Alex.Polyak@ottawa.ca), for follow-up questions.

### **Transportation**

- Follow Traffic Impact Assessment Guidelines
  - Ensure that the screening form is signed and stamped.
  - Proceed with the scoping report. Communication between the consultant and City is required at every step of the process.
  - The application cannot be deemed complete without the submission of the TIA Strategy. It is preferred to complete this step prior to application to allow time for potential RMA.
- Ensure that the site triangle at Duford and St. Joseph is at least 5mx5m.
- Noise Impact Studies required for the following at Site Plan:
  - Road (proximity to St Joseph/Duford); and,

- Stationary (if there will be any exposed mechanical equipment due to the proximity to neighbouring noise sensitive land uses).
- The clear throat requirement for 100-200 apartment units accessing an arterial is 25m.
- On site plan:
  - Show all details of the roads abutting the site up to and including the opposite curb; include such items as pavement markings, accesses and/or sidewalks.
  - Turning templates will be required for all accesses showing the largest vehicle to access the site; required for internal movements and at all access (entering and exiting and going in both directions).
  - Show all curb radii measurements; ensure that all curb radii are reduced as much as possible.
  - The aisle width requirement is 6.7m.
  - Sidewalk is to be continuous across access as per City Specification 7.1.
- The site is within 600m of future Place d’Orleans LRT Station – therefore TOD measures would apply. To achieve target mode shares within TOD zones, we highly recommend developments to provide as many TDM measures as possible.
- As the site proposed is residential, AODA legislation applies for all areas accessible to the public (i.e. outdoor pathways, parking, etc.).
- St. Joseph and Duford have protected rights of way of 37.5m and 24m, respectively according to the Official Plan. A widening might be required along the St. Joseph frontage, clearly show the ultimate property line as shown in the Orleans Corridor Secondary Plan, it appears that a 1m widening is required. Tree planting as shown on the concept plan would be temporary until the ultimate cross-section is constructed.
- While the location of the St. Joseph access is preferred as far from the intersection of St Joseph and Duford, as shown, it may require a median extension to prevent westbound and northbound left turns. This would be at the applicant’s cost. Explore the possibility of providing access from Duford.
- Consider locating the bicycle parking at grade, ensure that the number of bicycle parking spaces are shown on the site plan.

Feel free to contact the Transportation Project Manager, Patrick McMahon, at [[patrick.mcmahon@ottawa.ca](mailto:patrick.mcmahon@ottawa.ca)], for follow-up questions.

### **Parkland**

- A new Parkland Dedication By-law, [By-law No. 2022-280](#), was approved by Council on August 31, 2022. The By-law increases the required parkland conveyance for mid-rise and high-rise residential development and includes one-year transition policies for in-stream development and building permit applications or those that met the requirements for completeness by September 1, 2022.

### **City Surveyor**

- The determination of property boundaries, minimum setbacks and other regulatory constraints are a critical component of development. An Ontario Land Surveyor (O.L.S.) needs to be consulted at the outset of a project to ensure properties are properly defined and can be used as the geospatial framework for the development.
- Topographic details may also be required for a project and should be either carried out by the O.L.S. that has provided the Legal Survey or done in consultation with the O.L.S. to ensure that the project is integrated to the appropriate control network.

Questions regarding the above requirements can be directed to the City’s Surveyor, Bill Harper, at [Bill.Harper@ottawa.ca](mailto:Bill.Harper@ottawa.ca)

## Waste Services

- New multi-unit residential development, defined as containing six (6) or more units, intending to receive City waste collection services will be required, as of June 1, 2022, to participate in the City's Green Bin program in accordance with Council's approval of the [multi-residential waste diversion strategy](#). The development must include adequate facilities for the proper storage of allocated garbage, recycling, and green bin containers and such facilities built in accordance with the approved site design. Questions regarding this change and requirements can be directed to [Andre.Laplante@ottawa.ca](mailto:Andre.Laplante@ottawa.ca).
- A project of this size will be on private services and

## Other

- Contact the Conservation Authority (RVCA) Office for their requirements
- Plans are to be standard A1 size (594 mm x 841 mm) or Arch D size (609.6 mm x 914.4 mm) sheets, dimensioned in metric and utilizing an appropriate Metric scale (1:200, 1:250, 1:300, 1:400 or 1:500).
- All PDF submitted documents are to be unlocked, flattened and not saved as a portfolio file. .
- Please use the standard border (below) A0.1 Place on all plans; DWG # and D07 # as per sample

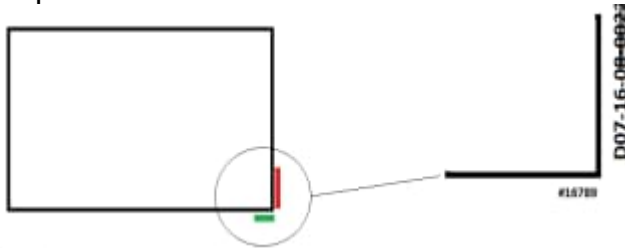

Use Bold Black text: Your Numbers are as per the colours listed here. DWG XXXXX (place number on the bottom right) D07 Number D07-12-23-xxxx.

- For information/question related to Development Charge, please contact AJ Mohmmand, Development Information Officer, Suburban East at [DIOCentrum@ottawa.ca](mailto:DIOCentrum@ottawa.ca) or 613-580-2424, ext. 29674
- For sites containing one or more buildings with a total GFA greater than 2000 square metres with more than 75 units
  - A Waste Reduction Workplan Summary is required for the construction project as required by O.Reg. 102/94, being "Waste Audits and Waste Reduction Work Plans" made under the Environmental Protection Act, RSO 1990, c E.19, as amended.
- You are encouraged to contact the Ward Councillor, Councillor Luloff, about the proposal.

Please refer to the links to [Guide to preparing studies and plans](#) and [fees](#) for further information. Additional information is available related to [building permits](#), [development charges](#), and the [Accessibility Design Standards](#). Be aware that other fees and permits may be required, outside of the development review process. You may obtain background drawings by contacting [geoinformation@ottawa.ca](mailto:geoinformation@ottawa.ca).

It is anticipated that, as a result of the *More Homes for Everyone Act, 2022*, for applications for site plan approval and zoning by-law amendments, new processes in respect of pre-application consultation will be put in place. The new processes are anticipated to require a multiple phase pre-application consultation approach before an application will be deemed complete. Applicants who have not filed a complete application by the effective date may be required to undertake further pre-application consultation(s) consistent with the provincial changes. The by-laws to be amended include By-law 2009-320, the Pre-Consultation By-law, By-law 2022-239, the planning fees by-law and By-law 2022-254, the Information and Materials for Planning Application By-law.

These pre-con comments are valid for one year. If you submit a development application(s) after this time, you may be required to meet for another pre-consultation meeting and/or the submission requirements may

change. You are as well encouraged to contact us for a follow-up meeting if the plan/concept will be further refined.

Please do not hesitate to contact me if you have any questions.

Regards,

Steve Belan, MCIP, RPP

Planner Planning Services, Development Review Services  
Planning, Corporate Real Estate and Economic Development department (PRED)  
City of Ottawa / Ville d'Ottawa  
110 Laurier Avenue West, 4th Floor / 110, avenue Laurier Ouest, 4e étage  
Ottawa, ON K1P 1J1  
Telephone / tél.: 613-580-2424 ext./poste 27591  
E-mail / courriel: [Steve.Belan@ottawa.ca](mailto:Steve.Belan@ottawa.ca)

.

This e-mail originates from the City of Ottawa e-mail system. Any distribution, use or copying of this e-mail or the information it contains by other than the intended recipient(s) is unauthorized. Thank you.

Le présent courriel a été expédié par le système de courriels de la Ville d'Ottawa. Toute distribution, utilisation ou reproduction du courriel ou des renseignements qui s'y trouvent par une personne autre que son destinataire prévu est interdite. Je vous remercie de votre collaboration.

.

.

This e-mail originates from the City of Ottawa e-mail system. Any distribution, use or copying of this e-mail or the information it contains by other than the intended recipient(s) is unauthorized. Thank you.

Le présent courriel a été expédié par le système de courriels de la Ville d'Ottawa. Toute distribution, utilisation ou reproduction du courriel ou des renseignements qui s'y trouvent par une personne autre que son destinataire prévu est interdite. Je vous remercie de votre collaboration.

.



**CONSTRUCTION MANAGER**  
 Vuze Construction  
 Street \_\_\_\_\_ City \_\_\_\_\_  
 Quebec, ### ##  
 Tel: (819) 664-4195  
 Email: mchenier@vuzeconstruction.com

**PROJECT DEVELOPER**  
**Theberge Developments Ltd.**  
 1600 Laperrerie Ave Suite 205  
 Ottawa, ON K1Z 1B7  
 Tel: (613) 421-1515  
 Cell: (613) 880-5491  
 Email: joeytheberge@thebergehomes.com  
 Email: jeremy@thebergehomes.com

**PROJECT DEVELOPER**  
**Starwood Group Inc.**  
 188 Eglinton Avenue East Suite 800  
 Toronto, Ontario, M4P 2X7  
 Tel: (416) 482-4822  
 Fax: (416) 482-8224

**LEGAL DESCRIPTION**  
**TOPOGRAPHICAL PLAN OF SURVEY**  
**PART 1** Plan of  
**PART OF LOTS 1, 2, 3 AND 4**  
**REGISTERED PLAN 17**  
**CITY OF OTTAWA**  
 Surveyed by Annis, O'Sullivan, Vollebakk Ltd.

**URBAN PLANNER**  
**Fotenn Consultants Inc.**  
 396 Cooper Street, Suite 300  
 Ottawa, ON Canada, K2P 2H7  
 Tel: (613) 730-5709  
 Fax: (613) 730-1136  
 E-Mail: nahal@fotenn.com  
 E-Mail: alain@fotenn.com

**CIVIL ENGINEER**  
**McINTOSH PERRY**  
 115 Walgreen Road  
 Ottawa, ON K0A 1L0  
 Tel: (613) 836-2184  
 Fax: (613) 836-3742  
 Email: r.robineau@mcintoshperry.com

**LANDSCAPE ARCHITECT**  
**James B. Lennox & Associates Inc.**  
 Landscape Architects  
 3332 Carling Ave.  
 Ottawa, Ontario K2H 5A8  
 Tel: 613-722-5188  
 Fax: 1-866-343-3942  
 Email: ml@jbla.ca

**TRANSPORTATION ENGINEER**  
**CHG Transportation Inc.**  
 13 Markham Avenue  
 Ottawa, ON K2G 3Z1  
 Tel: (343) 999-9117  
 Cell: (613) 697-3797  
 Email: Christopher.Gordon@CHGTransportation.com  
 Email: john.kingsley@chgtransportation.com

**WIND / NOISE ENGINEER**  
**Gradient Wind Engineering**  
 127 Walgreen Road,  
 Ottawa, ON, Canada K0A 1L0  
 Tel: (613) 836-0934  
 Cell: (613) 226-5273  
 Email: joshua.foster@gradientwind.com

**SURVEYOR**  
**Annis O'Sullivan Vollebakk Ltd.**  
 Ontario Land Surveyors  
 14 Concourse Gate, Suite 500,  
 Nepean, Ontario K2E 7S6  
 Tel: (613) 727-0850  
 Fax: (613) 727-1079  
 E-Mail: Andys@aovltd.com

**PROJECT INFORMATION**

Zoning By-law 2008-250 Consolidation AM3(2015) S438	SITE AREA	0.264 ha.	2,643.97 sq. m. (28,459 sq. ft.)
<b>ZONING</b>	<b>REQUIRED</b>	<b>PROVIDED</b>	
BUILDING HEIGHT	16 STOREYS / 52.4m	18 STOREYS / 58.0m	
ALLOWABLE PROJECTION - AMENITY LEVEL	0.0m	6.0m	
GRADE (GEODETIC ELEVATION - ASL)	72.40m ASL	72.40m ASL	
DENSITY - MAXIMUM FLOOR SPACE INDEX	4.25	5.1	
FRONT YARD SETBACK - AS PER SCHEDULE S438	9.0m	9.3m	
CORNER YARD SETBACK (Saint Joseph / Duford Avenue)	3.5m / 0.0m	3.5m / 0.3m	
INTERIOR SIDE YARD SETBACK	0.0m	0.3m	
AMENITY AREA - TOTAL PER UNIT - 6.0m <sup>2</sup>	1,212m <sup>2</sup>	1,635m <sup>2</sup>	
AMENITY AREA - 50% COMMUNAL PER UNIT - 3.0m <sup>2</sup>	606m <sup>2</sup>	785m <sup>2</sup>	
RESIDENTIAL PARKING (AREA Z' - MIN. 0 / MAX. 1.75 PER UNIT)	MIN. 0 / MAX. 354	124	
VISITOR PARKING - 0.1 PER UNIT AFTER 12 UNITS	2	19	
COMMERCIAL PARKING (AREA Z')	NOT REQUIRED	230	
BICYCLE PARKING - RESIDENTIAL - 0.5 PER UNIT	104	8	
BICYCLE PARKING - COMMERCIAL - 1 PER 250m <sup>2</sup> GFA	2	8	
ASILE & DRIVEWAY MINIMUM / MAXIMUM WIDTH	6.0m / 6.7m	6.0m / 6.7m	
ST. JOSEPH BOULEVARD FRONTAGE MINIMUM GROUND FLOOR GLAZING	50%	± 65%	

IT IS THE RESPONSIBILITY OF THE APPROPRIATE CONTRACTOR TO CHECK AND VERIFY ALL DIMENSIONS ON SITE AND TO REPORT ALL ERRORS AND/OR OMISSIONS TO THE ARCHITECT.  
 ALL CONTRACTORS MUST COMPLY WITH ALL PERTINENT CODES AND BY-LAWS.  
 THIS DRAWING MAY NOT BE USED FOR CONSTRUCTION UNTIL SIGNED BY THE ARCHITECT.  
 DO NOT SCALE DRAWINGS.  
 COPYRIGHT RESERVED.

**NOTATION SYMBOLS:**

- Ⓢ INDICATES DRAWING NOTES, LISTED ON EACH SHEET.
- Ⓜ INDICATES ASSEMBLY TYPE: REFER TO TYPICAL ASSEMBLY SCHEDULE.
- Ⓦ INDICATES WINDOW TYPE: REFER TO WINDOW ELEVATIONS AND DETAILS ON A800 SERIES.
- Ⓝ INDICATES DOOR TYPE: REFER TO DOOR SCHEDULE AND DETAILS ON A800 SERIES.
- Ⓝ - DETAIL NUMBER
- Ⓝ - TITLE
- Ⓝ - SCALE
- Ⓝ - DETAIL REFERENCE PAGE
- Ⓝ - DETAIL CROSS REFERENCE PAGE



**PROJECT STATISTICS**

GROSS BUILDING (GFA DEFINED PER SECTIONAL CITY OF OTTAWA BYLAWS (OFFICIAL CODES FLOOR AREA))

PARKING LEVELS (3 TYPICAL)	N/A
GROUND FLOOR	259.8 sq. m. (2,798 sq. ft.)
1st FLOOR	452.4 sq. m. (4,870 sq. ft.)
2nd FLOOR	1,042.5 sq. m. (11,221 sq. ft.)
3rd & 4th FLOOR	2,085.0 sq. m. (22,442 sq. ft.)
5th to 17th FLOOR	13 x 714.0 sq. m. (99,805 sq. ft.)
18th FLOOR	552.0 sq. m. (5,941 sq. ft.)
MECHANICAL LEVEL	N/A
TOTAL AREA	13,674.6 sq. m. (147,192 sq. ft.)

**UNIT STATISTICS**

STUDIO UNIT	0
1 BEDROOM UNIT	25
1 BEDROOM + DEN UNIT	114
2 BEDROOM UNIT	65
3 BEDROOM UNIT	3
TOTAL	207

COMMERCIAL RETAIL: 190.0 sq. m. (2,050 sq. ft.)

**CAR PARKING**

REQUIRED BY ZONING BY-LAW

RESIDENCE	- AREA Z' NONE REQUIRED	0
VISITOR	- 0.1 PER DWELLING UNIT (AFTER 12 UNITS)	20
COMMERCIAL RETAIL	- AREA Z' NONE REQUIRED	0
TOTAL		20

PROVIDED

RESIDENCE	- 0.6 PER UNIT	124
VISITOR	- 0.1 PER UNIT (AFTER 12)	20
TOTAL		144

**BICYCLE PARKING**

REQUIRED

RESIDENCE	- 0.5 PER UNIT (206 UNITS)	103
COMMERCIAL RETAIL	- 1.0 PER 250m <sup>2</sup> OF G.F.A.	2
TOTAL		105

PROVIDED

EXTERIOR	8
INDOOR ON MEZZANINE FLOOR	230
TOTAL	238

**LOT COVERAGE**

PAVED SURFACE =	43.7 sq. m.	1.6%
BUILDING FOOTPRINT =	1,618.9 sq. m.	61.2%
LANDSCAPE OPEN SPACE =	981.4 sq. m.	37.2%
TOTAL =	2,643.97 sq. m.	100.0%

**AMENITY SPACE**

AT GRADE COMMUNAL =	150.0 sq. m.
GRND FLOOR AMENITY ROOM COMMUNAL =	175.0 sq. m.
1st FLOOR TERRACE COMMUNAL =	360.0 sq. m.
1st FLOOR TERRACE COMMUNAL =	30.0 sq. m.
ROOF INTERIOR COMMUNAL =	140.0 sq. m.
ROOF TOP COMMUNAL =	145.0 sq. m.
PRIVATE TERRACE =	885.0 sq. m.
PRIVATE BALCONIES =	395.0 sq. m.
TOTAL =	2,250.0 sq. m.
TOTAL COMMUNAL =	885.0 sq. m.
REQUIRED - 6.0M <sup>2</sup> PER UNIT (207) =	1,242.0 sq. m.
REQUIRED COMMUNAL @ 50% =	621.0 sq. m.

**SOLID WASTE (207 UNITS)**

GARBAGE - COMPACTED	- 0.11 PER UNIT	11 YARDS
RECYCLING GMP	- 0.018 PER UNIT	4 YARDS
RECYCLING FIBER	- 0.038 PER UNIT	8 YARDS
COMPOST	- 240L PER 50 UNITS	4

**ISSUED FOR OPA, ZA & SPC APPLICATION R03** Sept 04, 24

**ISSUED FOR FOUNDATION PERMIT** Aug. 15, 24

**ISSUED FOR OPA, ZA & SPC APPLICATION R02** July 31, 24

**ISSUED FOR OPA, ZA & SPC APPLICATION R01** Mar 15, 24

**ISSUED FOR 33% REVIEW** Sept 15, 23

**ISSUED FOR OPA, ZA & SPC APPLICATION** June 09, 23

**ISSUED FOR OWNER / CONSULTANT REVIEW** May 30, 23

**ISSUED FOR OWNER REVIEW** Dec. 22, 22

REVISIONS:

NO.	DESCRIPTION	DATE
1		
2		
3		
4		
5		
6		
7		
8		
9		
10		
11		
12		
13		
14		
15		
16		
17		
18		
19		
20		
21		
22		
23		
24		
25		
26		
27		
28		
29		
30		
31		
32		
33		
34		
35		
36		
37		
38		
39		
40		
41		
42		
43		
44		
45		
46		
47		
48		
49		
50		
51		
52		
53		
54		
55		
56		
57		
58		
59		
60		

ARCHITECT ASSOCIATION OF ARCHITECTS  
 REGISTERED PROFESSIONAL ARCHITECT  
 LICENSE #4375

SEAL DATE: STAMP DATE

CLIENT: **St. Joseph Inc.**  
**MASTERCRAFT STARWOOD**  
 Investment Builders Since 1951

**rla / architecture**  
 roderick lahey architect inc.  
 56 beech street, ottawa, ontario K1S 3J6  
 t. 613.724.9932 f. 613.724.1209 rla@architecture.ca

PROJECT TITLE: **3030 St. JOSEPH BOULIVARD**

OTTAWA ONTARIO

SHEET TITLE: **SITE PLAN**

DRAWN: R.V. CHECKED: R.V.  
 SCALE: 1:125 SHEET No. SP-1  
 PROJECT No. 2222



APPENDIX C  
WATERMAIN CALCULATIONS



## CCO-24-0142 - 3030 St Joseph Boulevard - Water Demands

Project:	3030 St Joseph Boulevard
Project No.:	CCO-24-0142
Designed By:	RRR
Checked By:	CJM
Date:	July 23, 2024
Site Area:	0.26 gross ha

<u>Residential</u>	NUMBER OF UNITS	UNIT RATE	
Single Family	homes	3.4	persons/unit
Semi-detached	homes	2.7	persons/unit
Townhouse	homes	2.7	persons/unit
Bachelor Apartment	0 units	1.4	persons/unit
1 Bedroom Apartment	153 units	1.4	persons/unit
2 Bedroom Apartment	50 units	2.1	persons/unit
3 Bedroom Apartment	4 units	3.1	persons/unit
Average Apartment	units	1.8	persons/unit

Total Population 332 persons

<u>Commercial</u>	190 m2
<u>Industrial - Light</u>	m2
<u>Industrial - Heavy</u>	m2

### AVERAGE DAILY DEMAND

DEMAND TYPE	AMOUNT	UNITS	
Residential	280	L/c/d	
Industrial - Light	35,000	L/gross ha/d	
Industrial - Heavy	55,000	L/gross ha/d	
Shopping Centres	2,500	L/(1000m <sup>2</sup> /d	
Hospital	900	L/(bed/day)	
Schools	70	L/(Student/d)	
Trailer Park with no Hook-Ups	340	L/(space/d)	
Trailer Park with Hook-Ups	800	L/(space/d)	
Campgrounds	225	L/(campsite/d)	
Mobile Home Parks	1,000	L/(Space/d)	
Motels	150	L/(bed-space/d)	
Hotels	225	L/(bed-space/d)	
Tourist Commercial	28,000	L/gross ha/d	
Other Commercial	28,000	L/gross ha/d	
AVERAGE DAILY DEMAND	Residential	1.08	L/s
	Commercial/Industrial/ Institutional	0.01	L/s



### MAXIMUM DAILY DEMAND

DEMAND TYPE	AMOUNT		UNITS
Residential	3.34	x avg. day	L/c/d
Industrial	1.5	x avg. day	L/gross ha/d
Commercial	1.5	x avg. day	L/gross ha/d
Institutional	1.5	x avg. day	L/gross ha/d
MAXIMUM DAILY DEMAND	Residential	3.59	L/s
	Commercial/Industrial/ Institutional	0.01	L/s

### MAXIMUM HOUR DEMAND

DEMAND TYPE	AMOUNT		UNITS
Residential	5.01	x avg. day	L/c/d
Industrial	1.8	x max. day	L/gross ha/d
Commercial	1.8	x max. day	L/gross ha/d
Institutional	1.8	x max. day	L/gross ha/d
MAXIMUM HOUR DEMAND	Residential	5.39	L/s
	Commercial/Industrial/ Institutional	0.02	L/s

WATER DEMAND DESIGN FLOWS PER UNIT COUNT  
CITY OF OTTAWA - WATER DISTRIBUTION GUIDELINES, JULY 2010

AVERAGE DAILY DEMAND	1.08	L/s
MAXIMUM DAILY DEMAND	3.60	L/s
MAXIMUM HOUR DEMAND	5.41	L/s





CCO-24-0142 - 3030 St Joseph Boulevard - Fire Underwriters Survey

Project: 3030 St Joseph Boulevard  
 Project No.: CCO-24-0142  
 Designed By: RRR  
 Checked By: CJM  
 Date: July 23, 2024

From the Fire Underwriters Survey (2020)

From Part II – Guide for Determination of Required Fire Flow Copyright I.S.O.:  
 City of Ottawa Technical Bulletin ISTB-2018-02 Applied Where Applicable

A. BASE REQUIREMENT (Rounded to the nearest 1000 L/min)

F = 220 x C x vA Where: F = Required fire flow in liters per minute  
 C = Coefficient related to the type of construction.  
 A = The total floor area in square meters (including all storey's, but excluding basements at least 50 percent below grade) in the building being considered.

Construction Type Non-Combustible Construction

C 0.8 A 13,317.3 m<sup>2</sup>

Total Floor Area (per the 2020 FUS Page 20 - Total Effective Area) 3,309.4 m<sup>2</sup> Protected Vertical Openings

Calculated Fire Flow	10,124.9 L/min
	10,000.0 L/min

B. REDUCTION FOR OCCUPANCY TYPE (No Rounding)

From Page 24 of the Fire Underwriters Survey:  
 Non-Combustible -25%

Fire Flow	7,500.0 L/min
-----------	---------------

C. REDUCTION FOR SPRINKLER TYPE (No Rounding)

Fully Supervised Sprinklered -50%

Reduction	-3,750.0 L/min
-----------	----------------

D. INCREASE FOR EXPOSURE (No Rounding)

	Separation Distance (m)	Cons.of Exposed Wall	Length Exposed Adjacent Wall (m)	Height (Stories)	Length-Height Factor	
Exposure 1	Over 30 m	Ordinary - Mass Timber (Unprotected)	55	2	110.0	0%
Exposure 2	Over 30 m	Ordinary - Mass Timber (Unprotected)	10	2	20.0	0%
Exposure 3	Over 30 m	Ordinary - Mass Timber (Unprotected)	10	2	20.0	0%
Exposure 4	0 to 3	Ordinary - Mass Timber (Unprotected)	25	2	50.0	17%
					% Increase*	17%

Increase*	1,275.0 L/min
-----------	---------------

E. Total Fire Flow (Rounded to the Nearest 1000 L/min)

Fire Flow	5,025.0 L/min
Fire Flow Required**	5,000.0 L/min

\*In accordance with Part II, Section 4, the Increase for separation distance is not to exceed 75%  
 \*\*In accordance with Section 4 the Fire flow is not to exceed 45,000 L/min or be less than 2,000 L/min



## CCO-24-0142 - 3030 St Joseph Boulevard - Boundary Condition Unit Conversion

---

Project: 3030 St Joseph Boulevard

Project No.: CCO-24-0142

Designed By: RRR

Checked By: CJM

Date: July 23, 2024

---

### Boundary Conditions Unit Conversion

---

#### St. Joseph Boulevard

Scenario	Height (m)	Elevation (m)	m H <sub>2</sub> O	PSI	kPa
<b>Avg. DD</b>	114.1	69.4	44.7	63.6	438.5
<b>Fire Flow (83 L/s or 5,000 L/min)</b>	111.2	69.4	41.8	59.5	410.1
<b>Peak Hour</b>	109.4	69.4	40.0	56.9	392.4

Ground Elevation = 69.4m



# 3030 St-Joseph - Existing Hydrant Coverage Per 2020 FUS Guideline

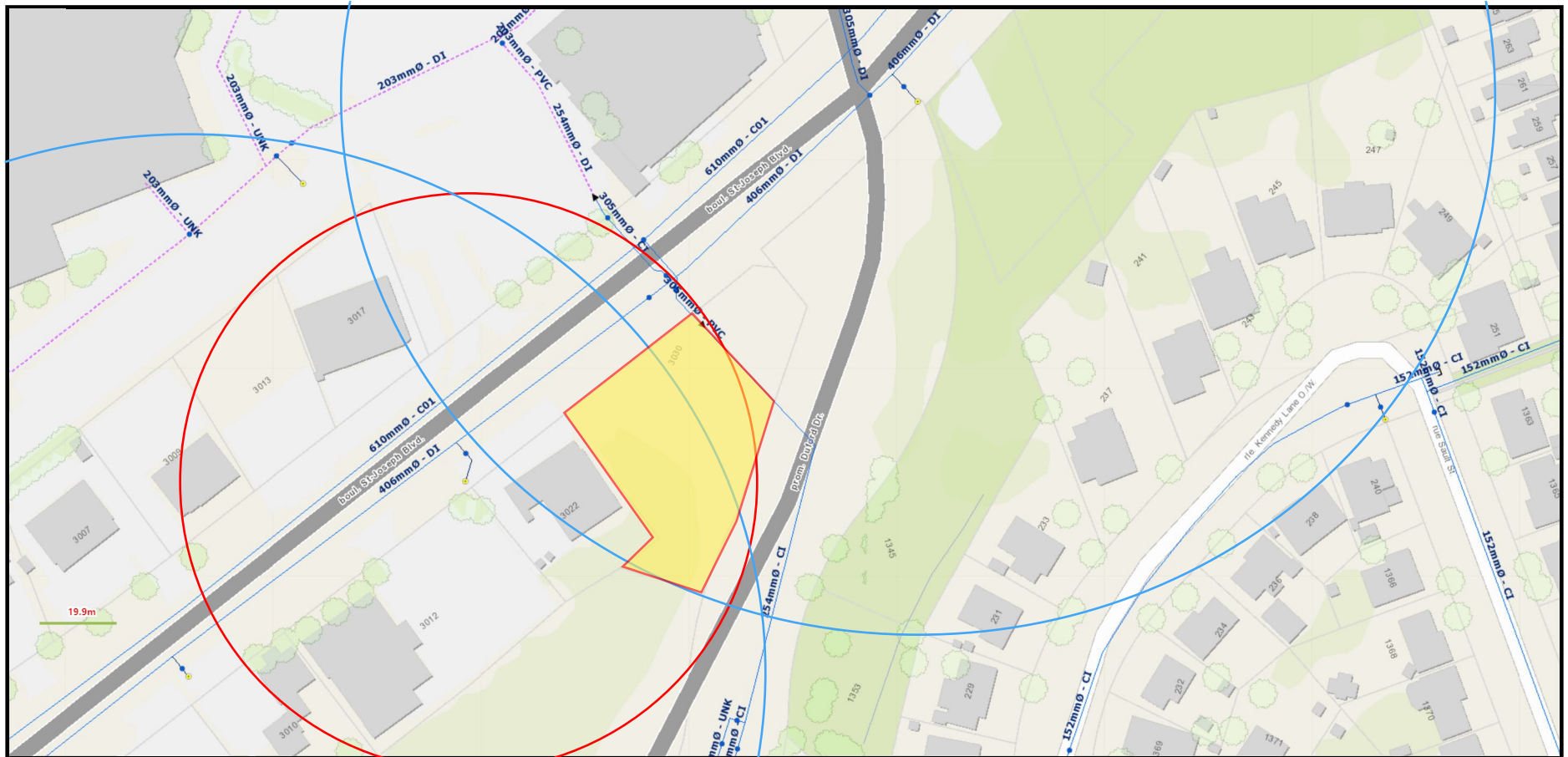

Existing Hydrants Within 75m: 1

Existing Hydrants Within 150m: 2

APPENDIX D  
SANITARY CALCULATIONS



## CCO-24-0142 - 3030 St Joseph - Sanitary Demands

Project:	3030 St Joseph
Project No.:	CCO-24-0142
Designed By:	R.R.R.
Checked By:	C.J.M.
Date:	July 23, 2024

Site Area	0.26	Gross ha	
1 Bedroom	153		1.40 Persons per unit
2 Bedroom	50		2.10 Persons per unit
3 Bedroom	4		3.10 Persons per unit
Bachelor	0		1.40 Persons per unit
Total Population	332	Persons	
Commercial Area	190.00	m <sup>2</sup>	
Amenity Space	2250.00	m <sup>2</sup>	

### DESIGN PARAMETERS

Institutional/Commercial Peaking Factor	1	*Check technical bulleting (Either use 1.0 or 1.5)
Residential Peaking Factor	3.45	* Using Harmon Formula = $1 + (14 / (4 + P^{0.5})) * 0.8$ where P = population in thousands, Harmon's Correction Factor = 0.8
Mannings coefficient (n)	0.013	
Demand (per capita)	280	L/day
Infiltration allowance	0.33	L/s/Ha

### EXTRANEOUS FLOW ALLOWANCES

Infiltration / Inflow	Flow (L/s)
Dry	0.01
Wet	0.07
Total	0.09

### AVERAGE DAILY DEMAND

DEMAND TYPE	AMOUNT	UNITS	POPULATION / AREA	Flow (L/s)
Residential	280	L/c/d	332	1.08
Industrial - Light**	35,000	L/gross ha/d		0
Industrial - Heavy**	55,000	L/gross ha/d		0
Commercial / Amenity	2,800	L/(1000m <sup>2</sup> / d )	2440.00	0.08
Hospital	900	L/(bed/day)		0
Schools	70	L/(Student/d)		0
Trailer Parks no Hook-Ups	340	L/(space/d)		0
Trailer Park with Hook-Ups	800	L/(space/d)		0
Campgrounds	225	L/(campsite/d)		0
Mobile Home Parks	1,000	L/(Space/d)		0
Motels	150	L/(bed-space/d)		0
Hotels	225	L/(bed-space/d)		0
Office	75	L/7.0m <sup>2</sup> /d		0
Tourist Commercial	28,000	L/gross ha/d		0
Other Commercial	28,000	L/gross ha/d		0



AVERAGE RESIDENTIAL FLOW	1.08	L/s
PEAK RESIDENTIAL FLOW	3.71	L/s
AVERAGE ICI FLOW	0.08	L/s
PEAK INSTITUTIONAL/COMMERCIAL FLOW	0.08	L/s
PEAK INDUSTRIAL FLOW	0.00	L/s
TOTAL PEAK ICI FLOW	0.08	L/s

TOTAL SANITARY DEMAND

TOTAL ESTIMATED AVERAGE DRY WEATHER FLOW	1.17	L/s
TOTAL ESTIMATED PEAK DRY WEATHER FLOW	3.80	L/s
TOTAL ESTIMATED PEAK WET WEATHER FLOW	3.88	L/s

\*\* PEAK INDUSTRIAL FLOW PER CITY OF OTTAWA SEWER DESIGN GUIDELINES APPENDIX 4B

SANITARY SEWER DESIGN SHEET

PROJECT: CCO-24-0142  
 LOCATION: 3030 St. Joseph



LOCATION				RESIDENTIAL								ICI AREAS								INFILTRATION ALLOWANCE			FLOW		SEWER DATA					
1	2	3	4	5	6	7	8	9	10	11	12	13	14	15	16	17	18	19	20	21	22	23	24	25	26	27	28	29	30	31
STREET	AREA ID	FROM MH	TO MH	UNIT TYPES				AREA (ha)	POPULATION		PEAK FACTOR	PEAK FLOW (L/s)	AREA (ha)						PEAK FLOW (L/s)	AREA (ha)		FLOW (L/s)	DESIGN FLOW (L/s)	CAPACITY (L/s)	LENGTH (m)	DIA (mm)	SLOPE (%)	VELOCITY (full) (m/s)	AVAILABLE CAPACITY	
				BAC/1-BED	2-BED	3-BED	IND		CUM	INSTITUTIONAL			COMMERCIAL	INDUSTRIAL	IND	CUM	IND	CUM		IND	CUM								IND	CUM
St Joseph Boulevard		BLDG	MH1A	153	50	4		0.26	332.0	332.0	3.45	3.71		0.00	0.24	0.24		0.00	0.08	0.26	0.26	0.09	3.88	34.22	3.00	200	1.00	1.055	30.34	88.67
		MH1A	EX. Sewer						0.0	332.0	3.45	3.71		0.00		0.24		0.00	0.08	0.00	0.26	0.09	3.88	34.22	16.85	200	1.00	1.055	30.34	88.67
Design Parameters:				Notes:								Designed: RRR								No.		Revision						Date		
Residential				ICI Areas								Checked: AM								Project No.:		CCO-24-0142						Sheet No:		
BAC/1-BED 1.4 p/p/u				1. Mannings coefficient (n) = 0.013																										
2-BED 2.1 p/p/u				2. Demand (per capita): 280 L/day																										
3-BED 3.1 p/p/u				3. Infiltration allowance: 0.33 L/s/Ha																										
Other 60 p/p/Ha				4. Residential Peaking Factor: Harmon Formula = 1+(14/(4+P*0.5)*0.8) where P = population in thousands																										
																												1 of 1		



SANITARY SEWER RELOCATION DESIGN SHEET

PROJECT: CCO-24-0142  
 LOCATION: 3030 St. Joseph



LOCATION				RESIDENTIAL									ICI AREAS						INFILTRATION ALLOWANCE			FLOW		SEWER DATA								
1	2	3	4	5	6	7	8	9	10	11	12	13	14	15	16	17	18	19	20	21	22	23	24	25	26	27	28	29	30	31		
STREET	AREA ID	FROM MH	TO MH	UNIT TYPES				AREA (ha)	POPULATION		PEAK FACTOR	PEAK FLOW (L/s)	AREA (ha)						PEAK FLOW (L/s)	AREA (ha)		DESIGN FLOW (L/s)	CAPACITY (L/s)	LENGTH (m)	DIA (mm)	SLOPE (%)	VELOCITY (full) (m/s)	AVAILABLE CAPACITY				
				BAC/1-BED	2-BED	3-BED	IND		CUM	INSTITUTIONAL			COMMERCIAL		INDUSTRIAL		IND	CUM		IND	CUM							L/s	(%)	L/s	(%)	
										IND			CUM	IND	CUM	IND	CUM	IND		CUM	IND							CUM				
St Joseph Blvd. Existing Downstream Capacity		MHSA4436	MHS20921																				118.97	12.02	450	0.16	0.725					
Proposed Alignment Duford Dr. to St Joseph Blvd.		MH2A	MH2B																				488.28	6.04	450	2.70	2.974					
		MH2B	MH2C																				488.73	35.49	450	2.70	2.977					
		MH2C	MH2D																				488.73	21.77	450	2.70	2.977					
		MH2D	MH2E (TIE INTO EX. SEWER)																				458.86	39.54	450	2.38	2.795					
Design Parameters:				Notes:									Designed: RRR						No.			Revision						Date				
Residential				ICI Areas									Checked: AM						Project No.: CCO-24-0142									Sheet No:				
BAC/1-BED 1.4 p/p/u				1. Mannings coefficient (n) = 0.013																												
2-BED 2.1 p/p/u				2. Demand (per capita): 280 L/day																												
3-BED 3.1 p/p/u				3. Infiltration allowance: 0.33 L/s/Ha																												
Other 60 p/p/Ha				4. Residential Peaking Factor: Harmon Formula = 1+(14/(4+P^0.5)*0.8) where P = population in thousands																												
Note: Capacity of proposed alignment exceeds immediate existing downstream capacity between MHSA4436 to MHS20921. Due to the complexity of the downstream network, the City will need to advise of any downstream constraints.																									1 of 1							

# 3030 St-Joseph Sanitary Trunk Figure

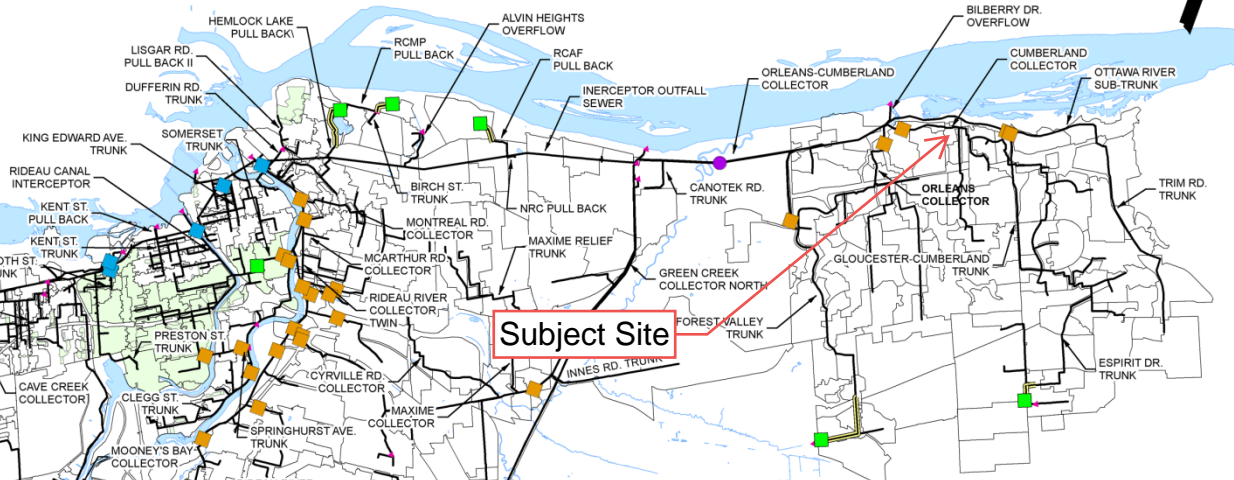

APPENDIX E  
PRE-DEVELOPMENT DRAINAGE PLAN



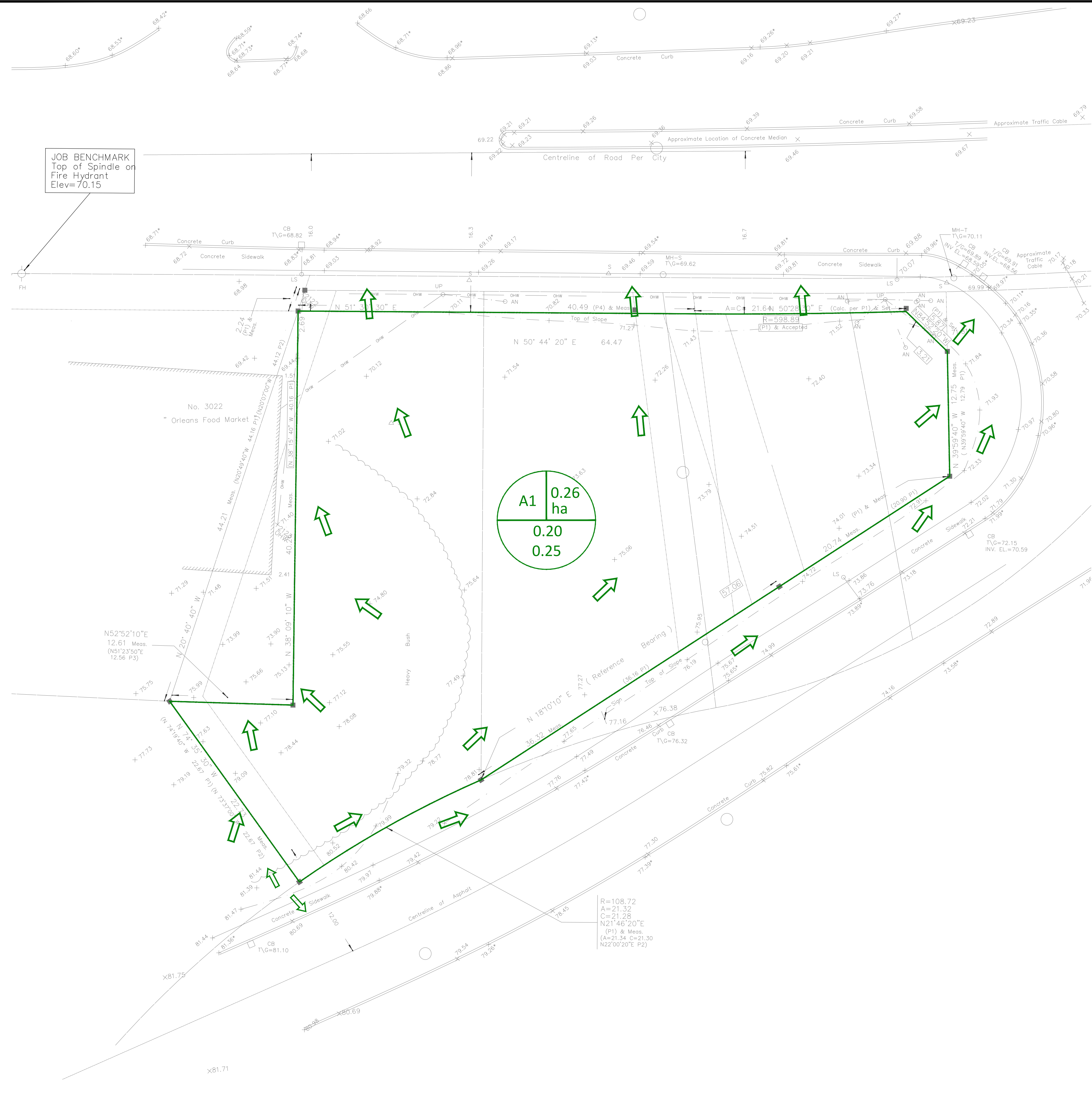

**GENERAL NOTES**

1. THE ORIGINAL TOPOGRAPHY, GROUND ELEVATION AND SURVEY DATA SHOWN ARE SUPPLIED FOR INFORMATION PURPOSES ONLY, AND IMPLY NO GUARANTEE OF ACCURACY. IT SHALL BE THE RESPONSIBILITY OF THE CONTRACTOR TO VERIFY ALL INFORMATION SHOWN.
2. THIS PLAN IS NOT A CADASTRAL SURVEY SHOWING LEGAL PROPERTY BOUNDARIES AND EASEMENTS. THE PROPERTY BOUNDARIES SHOWN HEREON HAVE BEEN DERIVED FROM INFORMATION SUPPLIED BY ANNIS, O'SULLIVAN, VOLLEBEK LTD. AND CANNOT BE RELIED UPON TO BE ACCURATE OR COMPLETE. THE PRECISE LOCATION OF THE CURRENT PROPERTY BOUNDARIES AND EASEMENTS CAN ONLY BE DETERMINED BY AN UP-TO-DATE LAND TITLES SEARCH AND A SUBSEQUENT CADASTRAL SURVEY PERFORMED AND CERTIFIED BY AN ONTARIO LAND SURVEYOR. THE BEARINGS DISPLAYED ARE ASTRONOMIC, DERIVED FROM PART OF THE EASTERLY LIMIT OF PLAN 50R-4499, SHOWN TO BE N 18°10'10" E. REFER TO THE SURVEY.
3. THE CONTRACTOR IS TO OBTAIN AND PAY FOR ALL NECESSARY PERMITS AND APPROVALS FROM THE CITY BEFORE COMMENCING CONSTRUCTION.
4. THE CONTRACTOR IS RESPONSIBLE FOR ALL LAYOUT.
5. THE CONTRACTOR IS TO DETERMINE THE EXACT LOCATION, SIZE, MATERIAL AND ELEVATION OF ALL EXISTING UTILITIES PRIOR TO COMMENCING CONSTRUCTION. PROTECT AND ASSUME ALL RESPONSIBILITY FOR EXISTING UTILITIES WHETHER OR NOT SHOWN ON THESE DRAWINGS. IF THERE IS ANY DISCREPANCY THE CONTRACTOR IS TO NOTIFY THE ENGINEER PROMPTLY.
6. RESTORE ALL TRENCHES AND SURFACES OF PUBLIC ROAD ALLOWANCES TO CONDITION EQUAL OR BETTER THAN ORIGINAL CONDITION AND TO THE SATISFACTION OF THE CITY AUTHORITIES.
7. EXCAVATE AND DISPOSE OF ALL EXCESS EXCAVATED MATERIAL, SUCH AS ASPHALT, CURBING AND DEBRIS, OFF SITE AS DIRECTED BY THE ENGINEER AND THE CITY.
8. TOPSOIL TO BE STRIPPED AND STOCKPILED FOR REHABILITATION. CLEAN FILL TO BE PLACED IN FILL AREAS AND COMPACTED TO 95% STANDARD PROCTOR DENSITY.
9. ALL DISTURBED AREAS TO BE RESTORED TO ORIGINAL CONDITION OR BETTER UNLESS OTHERWISE SPECIFIED.
10. THE CONTRACTOR SHALL BE RESPONSIBLE FOR ALL TRAFFIC CONTROL AND SAFETY MEASURES DURING THE CONSTRUCTION PERIOD, INCLUDING THE SUPPLY, INSTALLATION, AND REMOVAL OF ALL NECESSARY SIGNAGE, DELINEATORS, MARKERS AND BARRIERS.
11. DO NOT ALTER GRADING OF THE SITE WITHOUT PRIOR APPROVAL OF THE ENGINEER/CITY.
12. ALL ROADWAY, PARKING LOT, AND GRADING WORKS TO BE UNDERTAKEN IN ACCORDANCE WITH CITY STANDARDS AND SPECIFICATIONS. THE CONTRACTOR IS TO PROVIDE POSITIVE DRAINAGE AWAY FROM THE BUILDING.
13. CONTACT THE CITY FOR INSPECTION OF ROUGH GRADING OF PARKING LOTS, ROADWAYS AND LANDSCAPED AREAS PRIOR TO PLACEMENT OF ANY ASPHALT, TOPSOIL, SEED & MULCH AND/OR SOD.
14. ALL DIMENSIONS AND INVERTS MUST BE VERIFIED PRIOR TO CONSTRUCTION, IF THERE IS ANY DISCREPANCY THE CONTRACTOR IS TO NOTIFY THE ENGINEER PROMPTLY.
15. ELECTRICAL, GAS, TELEPHONE AND TELEVISION SERVICE LOCATIONS ARE SUBJECT TO THE INDIVIDUAL AGENCY:
  - ELECTRICAL SERVICE - HYDRO OTTAWA,
  - GAS SERVICE - ENBRIDGE,
  - TELEPHONE SERVICE - BELL CANADA,
  - TELEVISION SERVICE - ROGERS.
16. INSTALLATION TO BE IN ACCORDANCE WITH CURRENT CODES AND STANDARDS OF APPROVAL AGENCIES HYDRO ONE, BELL AND THE CITY.
17. CONTRACTOR TO ENSURE ALL APPLICABLE OPS SPECIFICATIONS ARE FOLLOWED DURING CONSTRUCTION
18. ALL PROPOSED CURB TO BE CONCRETE BARRIER CURB UNLESS OTHERWISE SPECIFIED.
19. THIS PLAN MUST BE READ IN CONJUNCTION WITH THE GEOTECHNICAL INVESTIGATION BY PATERSON GROUP, REPORT NO. PG6609-1
20. THE CONTRACTOR IS RESPONSIBLE FOR CONSTRUCTION PHASING AND LAYOUT. A PHASING PLAN SHALL BE ESTABLISHED FOR THE REALIGNMENT OF THE PROPOSED WATER AND SANITARY SERVICES TO ENSURE CONTINUAL SERVICE FOR THE OFF-SITE FLOWS.

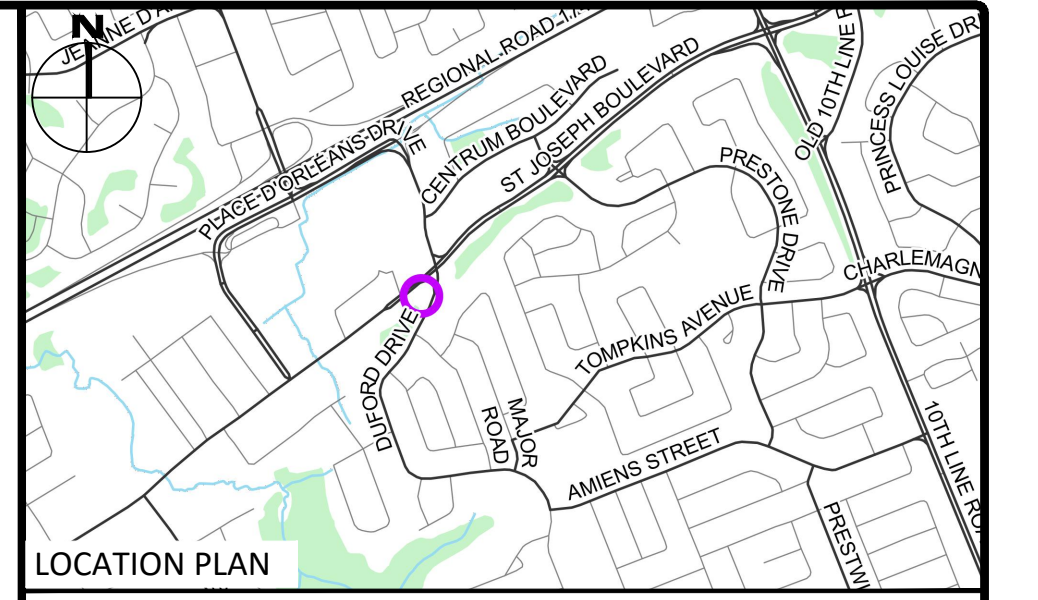

**LEGEND**

UC	BARRIER CURB & CURB DEPRESSION	SLOPING AT 3:1 UNLESS SPECIFIED
PC	PROPOSED CONCRETE PAVERS	95.94 93.20 PROPOSED ELEVATION EXISTING ELEVATION
MHR	STORM MANHOLE	95.94 93 TOP ELEVATION
CB	CATCHBASIN, CURB INLET OR DITCH INLET	X/W100.50 X/W90.50 TOP/BOTTOM WALL FACE ELEVATIONS
MHR	SANITARY MANHOLE	PROPOSED EMERGENCY OVERLAND FLOW ROUTE
PL	PROPERTY LINE	PRE AND POST-DEVELOPMENT DRAINAGE DIRECTIONS
WV	EX. WATER VALVE/CHAMBER	HEAVY DUTY SILT FENCE BARRIER PER OPSD 219.130
WV	PROP. VALVE PER CITY W24	BUILDING ENTRANCE
FH	FIRE HYDRANT	PROPOSED GRASS
W	PROPOSED WALL	CENTRELINE OF SWALE
SC	PROPOSED SIAMASE CONNECTION	PROPOSED ROAD/CUT AND REINSTATEMENT PER CITY
M	PROPOSED WATER METER AND REMOTE METER	TEMPORARY CONSTRUCTION MUD MAT PER C101 DETAIL
SC	PROPOSED CONCRETE SIDEWALK	CB SILT SACK PER C101 DETAIL
TR	PROP AND EX. REDUCER	① SERVICE/SEWER CROSSING
P	1/16" HYDRO DUCT PER ELEC.	L EX. UG STREET LIGHT
ST	EX. STM SEWER	TF EX. TRAFFIC LINE
SAN	EX. SAN SEWER	W EX. WATERMAIN
		GAS EX. GAS
		OHW EX. OHW
		GAS EX. EX. TRAFFIC CABLE
		BELL EX. BELL
		ROG EX. ROGERS

<b>SUBJECT TO APPROVAL</b>		
----------------------------	--	--

2	ISSUED FOR SITE PLAN CONTROL	MAR 04, 2024
1	ISSUED FOR SITE PLAN CONTROL	JUNE 02, 2023
No.	Revisions	Date

Check and verify all dimensions before proceeding with the work. Do not scale drawings.

**SCALE 1 : 200**

0 10 20 Metres

**McINTOSH PERRY**  
115 Walgreen Road, RR3, Carp, ON K0A 1L0  
Tel: 613-836-2184 Fax: 613-836-3742  
www.mcintoshperry.com

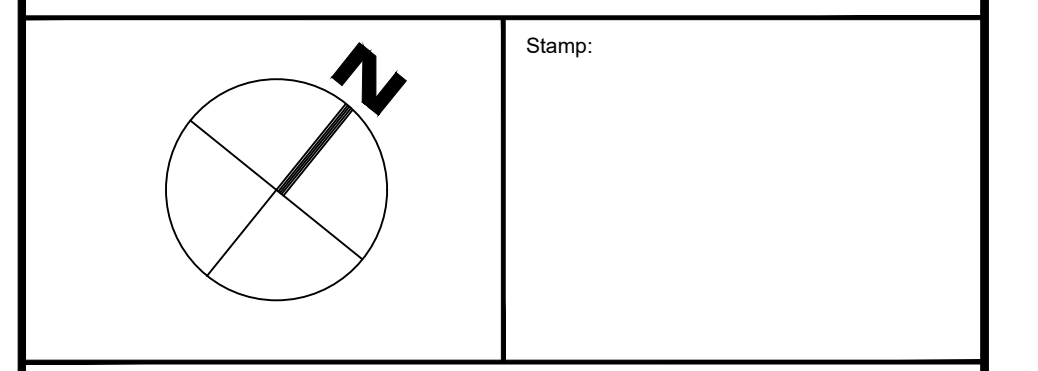

Client: **THEBERGE DEVELOPMENTS LTD**  
1600 LAPERRIERE AVE  
OTTAWA, ON K1Z 8P5

Project: **3030 ST. JOSEPH BOULEVARD**  
OTTAWA ON

Drawing Title: **PRE-DEVELOPMENT DRAINAGE PLAN**

Scale: 1:200	Project Number: CCO-24-0142
Drawn By: RRR	Checked By: RRR
Designed By: RRR	Drawing Number: PRE

FILENAME: U:\Information\3201\CCO-24-0142\Theberge - 2023\9 Joseph Blvd\12 - Drainage\CCO-24-0142 - PRESENTATION.dwg  
 DATE SAVED: Thursday, March 07, 2024, LAST SAVED BY: rrobson  
 LAST PLOTTED: Thursday, March 07, 2024, CBTREED, HP-CV51MDMD.ctb

APPENDIX F  
POST-DEVELOPMENT DRAINAGE PLAN



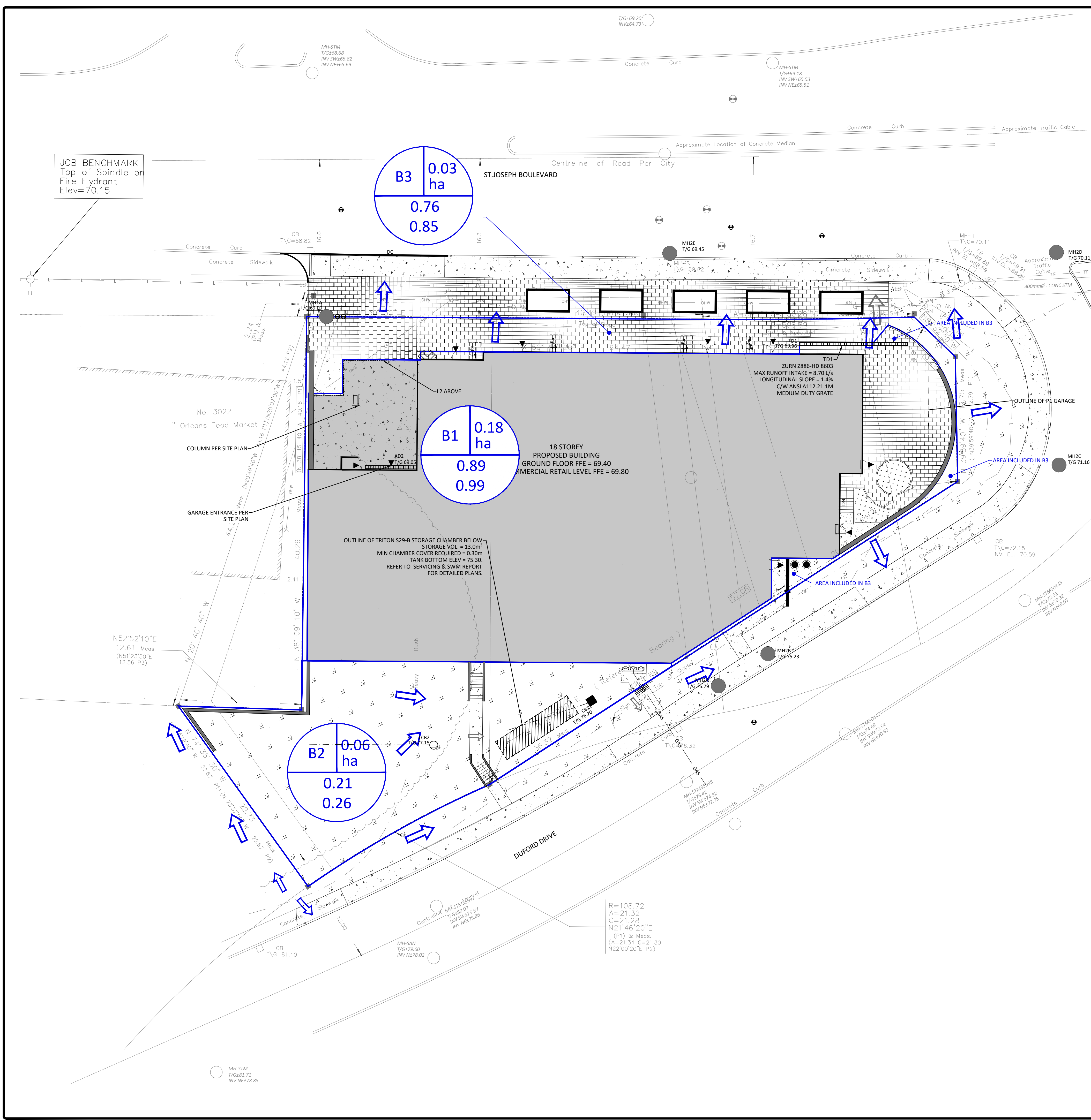

### GENERAL NOTES

1. THE ORIGINAL TOPOGRAPHY, GROUND ELEVATION AND SURVEY DATA SHOWN ARE SUPPLIED FOR INFORMATION PURPOSES ONLY, AND IMPLY NO GUARANTEE OF ACCURACY. IT SHALL BE THE RESPONSIBILITY OF THE CONTRACTOR TO VERIFY ALL INFORMATION SHOWN.
2. THIS PLAN IS NOT A CADASTRAL SURVEY SHOWING LEGAL PROPERTY BOUNDARIES AND EASEMENTS. THE PROPERTY BOUNDARIES SHOWN HEREON HAVE BEEN DERIVED FROM INFORMATION SUPPLIED BY ANNIS, O'SULLIVAN, VOLLEBEKK LTD. AND CANNOT BE RELIED UPON TO BE ACCURATE OR COMPLETE. THE PRECISE LOCATION OF THE CURRENT PROPERTY BOUNDARIES AND EASEMENTS CAN ONLY BE DETERMINED BY AN UP-TO-DATE LAND TITLES SEARCH AND A SUBSEQUENT CADASTRAL SURVEY PERFORMED AND CERTIFIED BY AN ONTARIO LAND SURVEYOR. THE BEARINGS DISPLAYED ARE ASTRONOMIC, DERIVED FROM PART OF THE EASTERLY LIMIT OF PLAN 50R-4499, SHOWN TO BE N 18°10'10"E. REFER TO THE SURVEY.
3. THE CONTRACTOR IS TO OBTAIN AND PAY FOR ALL NECESSARY PERMITS AND APPROVALS FROM THE CITY BEFORE COMMENCING CONSTRUCTION.
4. THE CONTRACTOR IS RESPONSIBLE FOR ALL LAYOUT.
5. THE CONTRACTOR IS TO DETERMINE THE EXACT LOCATION, SIZE, MATERIAL AND ELEVATION OF ALL EXISTING UTILITIES PRIOR TO COMMENCING CONSTRUCTION. PROTECT AND ASSUME ALL RESPONSIBILITY FOR EXISTING UTILITIES WHETHER OR NOT SHOWN ON THESE DRAWINGS. IF THERE IS ANY DISCREPANCY THE CONTRACTOR IS TO NOTIFY THE ENGINEER PROMPTLY.
6. RESTORE ALL TRENCHES AND SURFACES OF PUBLIC ROAD ALLOWANCES TO CONDITION EQUAL OR BETTER THAN ORIGINAL CONDITION AND TO THE SATISFACTION OF THE CITY AUTHORITIES.
7. EXCAVATE AND DISPOSE OF ALL EXCESS EXCAVATED MATERIAL, SUCH AS ASPHALT, CURBING AND DEBRIS, OFF SITE AS DIRECTED BY THE ENGINEER AND THE CITY.
8. TOPSOIL TO BE STRIPPED AND STOCKPILED FOR REHABILITATION. CLEAN FILL TO BE PLACED IN FILL AREAS AND COMPACTED TO 95% STANDARD PROCTOR DENSITY.
9. ALL DISTURBED AREAS TO BE RESTORED TO ORIGINAL CONDITION OR BETTER UNLESS OTHERWISE SPECIFIED.
10. THE CONTRACTOR SHALL BE RESPONSIBLE FOR ALL TRAFFIC CONTROL AND SAFETY MEASURES DURING THE CONSTRUCTION PERIOD, INCLUDING THE SUPPLY, INSTALLATION, AND REMOVAL OF ALL NECESSARY SIGNAGE, DELINEATORS, MARKERS AND BARRIERS.
11. DO NOT ALTER GRADING OF THE SITE WITHOUT PRIOR APPROVAL OF THE ENGINEER/CITY.
12. ALL ROADWAY, PARKING LOT, AND GRADING WORKS TO BE UNDERTAKEN IN ACCORDANCE WITH CITY STANDARDS AND SPECIFICATIONS. THE CONTRACTOR IS TO PROVIDE POSITIVE DRAINAGE AWAY FROM THE BUILDING.
13. CONTACT THE CITY FOR INSPECTION OF ROUGH GRADING OF PARKING LOTS, ROADWAYS AND LANDSCAPED AREAS PRIOR TO PLACEMENT OF ANY ASPHALT, TOPSOIL, SEED & MULCH AND/OR SOD.
14. ALL DIMENSIONS AND INVERTS MUST BE VERIFIED PRIOR TO CONSTRUCTION, IF THERE IS ANY DISCREPANCY THE CONTRACTOR IS TO NOTIFY THE ENGINEER PROMPTLY.
15. ELECTRICAL, GAS, TELEPHONE AND TELEVISION SERVICE LOCATIONS ARE SUBJECT TO THE INDIVIDUAL AGENCY:
  - ELECTRICAL SERVICE - HYDRO OTTAWA,
  - GAS SERVICE - ENBRIDGE,
  - TELEPHONE SERVICE - BELL CANADA,
  - TELEVISION SERVICE - ROGERS.
16. INSTALLATION TO BE IN ACCORDANCE WITH CURRENT CODES AND STANDARDS OF APPROVAL AGENCIES HYDRO ONE, BELL AND THE CITY.
17. CONTRACTOR TO ENSURE ALL APPLICABLE OPS SPECIFICATIONS ARE FOLLOWED DURING CONSTRUCTION.
18. ALL PROPOSED CURB TO BE CONCRETE BARRIER CURB UNLESS OTHERWISE SPECIFIED.
19. THIS PLAN MUST BE READ IN CONJUNCTION WITH THE GEOTECHNICAL INVESTIGATION BY PATERSON GROUP, REPORT NO. PG6609-1.
20. THE CONTRACTOR IS RESPONSIBLE FOR CONSTRUCTION PHASING AND LAYOUT. A PHASING PLAN SHALL BE ESTABLISHED FOR THE REALIGNMENT OF THE PROPOSED WATER AND SANITARY SERVICES TO ENSURE CONTINUAL SERVICE FOR THE OFF-SITE FLOWS.

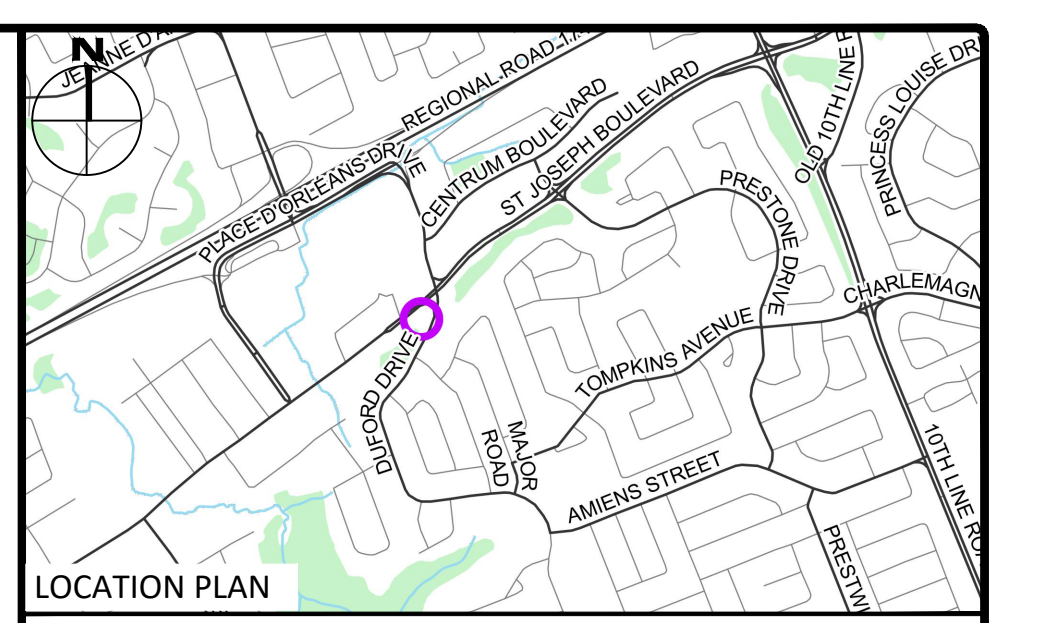

#### LEGEND

DC	BARRIER CURB & CURB DEPRESSION	SLOPING AT 3:1 UNLESS SPECIFIED	
PC	PROPOSED CONCRETE PAVERS	EXISTING ELEVATION	
MH#	STORM MANHOLE	TOP/BOTTOM WALL FACE ELEVATIONS	
CB	CATCHBASIN, CURB INLET OR DITCH INLET	PRE AND POST-DEVELOPMENT DRAINAGE DIRECTIONS	
MH#A	SANITARY MANHOLE	PROPOSED EMERGENCY OVERLAND FLOW ROUTE	
PL	PROPERTY LINE	HEAVY DUTY SILT FENCE BARRIER PER OPSD 219.130	
WV	EX. WATER VALVE/CHAMBER	BUILDING ENTRANCE	
WV	PROP. VALVE PER CITY W24	PROPOSED GRASS	
FH	FIRE HYDRANT	CENTRELINE OF SWALE	
W	PROPOSED WALL	PROPOSED ROAD CUT AND REINSTATEMENT PER CITY	
SC	PROPOSED SIAMASE CONNECTION		
M	PROPOSED WATER METER AND REMOTE METER		
SC	PROPOSED CONCRETE SIDEWALK	CB SILT SACK PER C101 DETAIL	
TR	PROP AND EX. REDUCER	SERVICE/SEWER CROSSING	
H	EX. HYDRO LUCT PER ELEC.	LF	EX. UG STREET LIGHT
W	EX. STM SEWER	T	EX. TRAFFIC LINE
W	EX. SAN SEWER	W	EX. WATERMAIN
		GAS	EX. GAS
		OHW	EX. OHW
		GAS	EX. TRAFFIC CABLE
		BELL	EX. BELL
		ROG	EX. ROGERS

<b>SUBJECT TO APPROVAL</b>		
3	ISSUED FOR SITE PLAN CONTROL	JUL 25, 2024
2	ISSUED FOR SITE PLAN CONTROL	MAR 04, 2024
1	ISSUED FOR SITE PLAN CONTROL	JUNE 02, 2023
No.	Revisions	Date
Check and verify all dimensions before proceeding with the work. Do not scale drawings.		

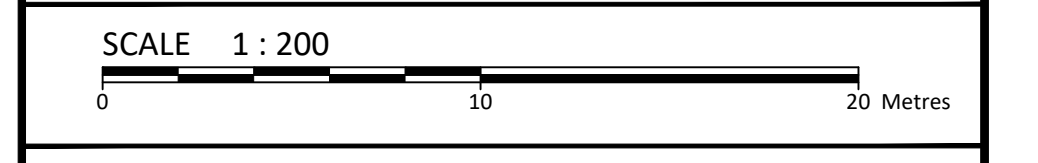

115 Walgreen Road, R.R.3  
Carp, ON K0A 1L0  
Tel: 613-836-2184  
Fax: 613-836-3742  
www.egis-group.com

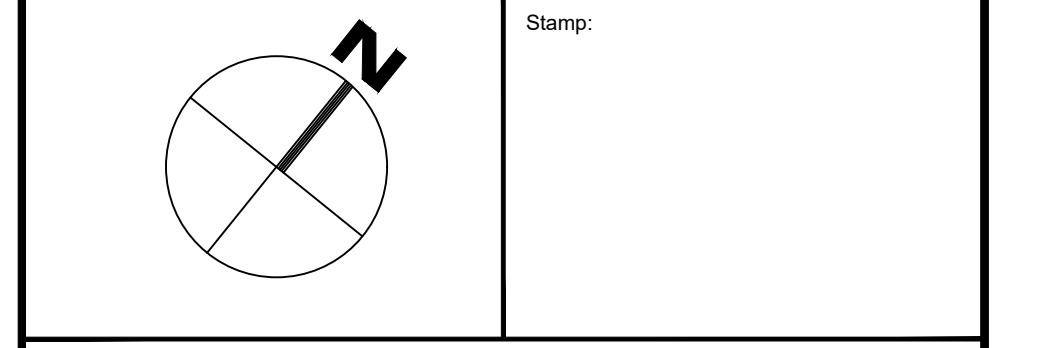

Client: **THEBERGE DEVELOPMENTS LTD**  
1600 LAPERRIERE AVE  
OTTAWA, ON K1Z 8P5

Project: **3030 ST. JOSEPH BOULEVARD**  
OTTAWA ON

Drawing Title: **POST-DEVELOPMENT DRAINAGE PLAN**

Scale: 1:200	Project Number: CCO-24-0142
Drawn By: RRR	
Checked By: AM	Drawing Number: POST
Designed By: RRR	

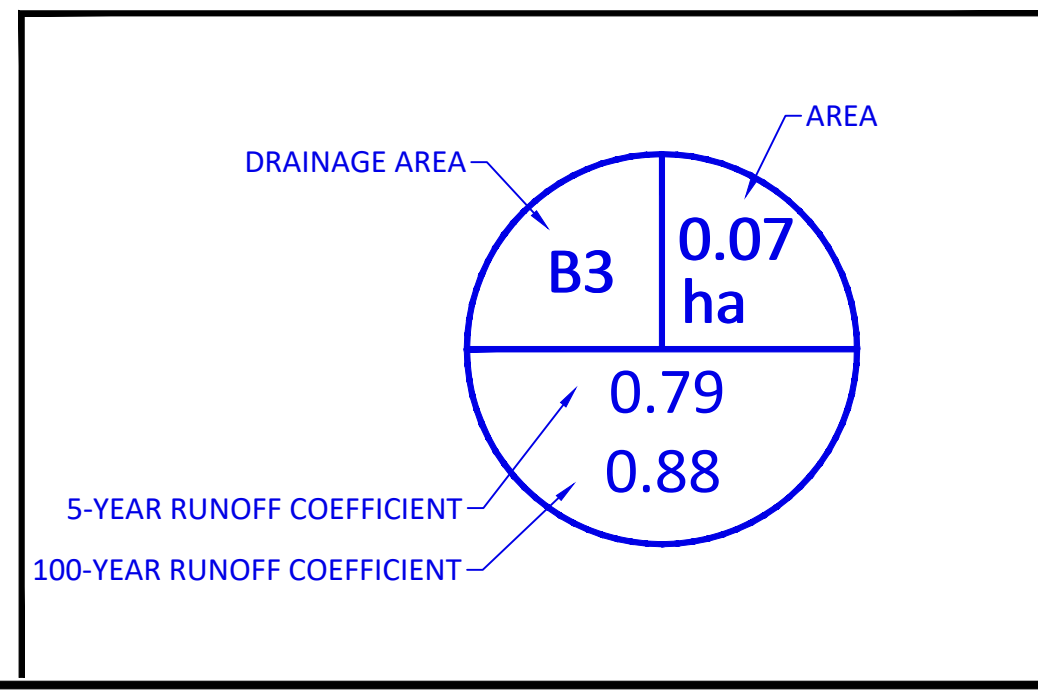

FILENAME: U:\Information\2024\CCO-24-0142\Theberge - 3030 St Joseph Blvd\12 - Drainage\CCO-24-0142 - PRESENTATION.dwg  
 USER: RRR, Tuesday, July 23, 2024, 1:51 PM  
 LAST SAVED: Tuesday, July 23, 2024, 1:51 PM  
 LAST PLOTTED: Tuesday, July 23, 2024, 1:51 PM  
 C:\Users\RRR\AppData\Local\Temp\1\12-Drainage\CCO-24-0142 - PRESENTATION.dwg

APPENDIX G  
STORMWATER MANAGEMENT CALCULATIONS





Tc (min)	Intensity (mm/hr)		
	5-Year	100-Year	
10	104.2	178.6	PRE-DEVELOPMENT
10	104.2	178.6	POST-DEVELOPMENT

C-Values	
Impervious	0.90
Gravel	0.60
Pervious	0.20

Pre-Development Runoff Coefficient

Drainage Area	Impervious Area (m <sup>2</sup> )	Gravel (m <sup>2</sup> )	Pervious Area (m <sup>2</sup> )	Average C (5-year)	Average C (100-year)
A1	0	0	2,643	0.20	0.25

Pre-Development Runoff Calculations

Drainage Area	Area (ha)	C 5-Year	C 100-Year	Tc (min)	Q (L/s)	
					5-Year	100-Year
A1	0.26	0.20	0.25	10	15.31	32.79
Total	0.26				15.31	32.79

Post-Development Runoff Coefficient

Drainage Area	Impervious Area (m <sup>2</sup> )	Gravel (m <sup>2</sup> )	Pervious Area (m <sup>2</sup> )	Average C (5-year)	Average C (100-year)
B1	1,781	0	18	0.89	0.99
B2	67	0	501	0.28	0.34
B3	219	0	56	0.76	0.85

Post-Development Runoff Calculations

Drainage Area	Area (ha)	C 5-Year	C 100-Year	Tc (min)	Q (L/s)		
					5-Year	100-Year	
B1	0.180	0.89	0.99	10	46.54	88.64	Restricted
B2	0.057	0.28	0.34	10	4.65	9.54	Restricted
B3	0.028	0.76	0.85	10	6.04	11.58	Unrestricted
Total	0.26				57.22	109.75	

Required Restricted Flow

Drainage Area	Area (ha)	C 5-Year	Tc (min)	Q (L/s)
				5-Year
A1	0.26	0.20	10	15.31

Post-Development Restricted Runoff Calculations

Drainage Area	Unrestricted Flow (L/S)		Restricted Flow (L/S)		Storage Required (m <sup>3</sup> )		Storage Provided (m <sup>3</sup> )	
	5-year	100-Year	5-Year	100-Year	5-Year	100-Year	5-Year	100-Year
B1	46.54	88.64	1.26	2.40	55.0	102.3	102.3	102.3
B2	4.65	9.54	1.10	1.30	2.4	6.5	13.0	13.0
B3	6.04	11.58	6.04	11.58				
Total	57.22	109.75	8.40	15.28	57.48	108.79	115.26	115.26



Storage Requirements for Area B1

5-Year Storm Event

Tc (min)	I (mm/hr)	Runoff (L/s) B1	Allowable Outflow (L/s)	Runoff to be Stored (L/s)	Storage Required (m <sup>3</sup> )
200	13.0	5.81	1.26	4.55	54.56
210	12.6	5.63	1.26	4.37	55.04
220	12.1	5.40	1.26	4.14	54.71
230	11.7	5.23	1.26	3.97	54.73
240	11.3	5.05	1.26	3.79	54.54

Maximum Storage Required 5-year = 55 m<sup>3</sup>

100-Year Storm Event

Tc (min)	I (mm/hr)	Runoff (L/s) B1	Allowable Outflow (L/s)	Runoff to be Stored (L/s)	Storage Required (m <sup>3</sup> )
190	22.9	11.37	2.40	8.97	102.24
200	22.0	10.92	2.40	8.52	102.26
210	21.1	10.47	2.40	8.07	101.74
220	20.4	10.13	2.40	7.73	102.00
230	19.7	9.78	2.40	7.38	101.84
240	19.0	9.43	2.40	7.03	101.26
250	18.4	9.13	2.40	6.73	101.01
260	17.8	8.84	2.40	6.44	100.41
270	17.3	8.59	2.40	6.19	100.25
280	16.8	8.34	2.40	5.94	99.79

Maximum Storage Required 100-year = 102 m<sup>3</sup>

5-Year Storm Event Storage Summary

Storage Available (m <sup>3</sup> ) = 102.3	*
Storage Required (m <sup>3</sup> ) = 55.0	

100-Year Storm Event Storage Summary

Storage Available (m <sup>3</sup> ) = 102.3	*
Storage Required (m <sup>3</sup> ) = 102.3	

\*Available Storage from internal cistern

Storage Requirements for Area B2

5-Year Storm Event

Tc (min)	I (mm/hr)	Runoff (L/s) B2	Allowable Outflow (L/s)	Runoff to be Stored (L/s)	Storage Required (m <sup>3</sup> )
5	141.2	6.30	1.10	5.20	1.56
10	104.2	4.65	1.10	3.55	2.13
15	83.6	3.73	1.10	2.63	2.37
20	70.3	3.13	1.10	2.03	2.44
25	60.9	2.72	1.10	1.62	2.42

Maximum Storage Required 5-year = 2.4 m<sup>3</sup>

100-Year Storm Event

Tc (min)	I (mm/hr)	Runoff (L/s) B2	Allowable Outflow (L/s)	Runoff to be Stored (L/s)	Storage Required (m <sup>3</sup> )
5	242.7	12.96	1.30	11.66	3.50
15	142.9	7.63	1.30	6.33	5.70
25	103.8	5.54	1.30	4.24	6.37
35	82.6	4.41	1.30	3.11	6.54
45	69.1	3.69	1.30	2.39	6.46
55	59.6	3.18	1.30	1.88	6.22
65	52.6	2.81	1.30	1.51	5.89
75	47.3	2.53	1.30	1.23	5.52
85	43.0	2.30	1.30	1.00	5.08
95	39.4	2.10	1.30	0.80	4.59

Maximum Storage Required 100-year = 6.5 m<sup>3</sup>

Storage Available in Triton S-29B Storage Tank\* (m<sup>3</sup>) = 13 (m<sup>3</sup>)

Refer to manufacturer's specification sheet in Appendix G for full storage tank details/specifications.

5-Year Storm Event Storage Summary

Storage Available (m <sup>3</sup> ) = 13.0
Storage Required (m <sup>3</sup> ) = 2.4

100-Year Storm Event Storage Summary

Storage Available (m <sup>3</sup> ) = 13.0
Storage Required (m <sup>3</sup> ) = 6.5



Time of Concentration Pre-Development

Drainage Area ID	Sheet Flow Distance (m)	Slope of Land (%)	Tc (min) (5-Year)	Tc (min) (100-Year)
A1	44	10.00	9	9

Therefore, a Tc of 10 can be used

$$T_c = (3.26(1.1-c)L^{0.5}/S^{0.33})$$

c = Balanced Runoff Coefficient

L = Length of drainage area

S = Average slope of watershed

# Area B2 ICD

Chart 1: LMF 14 Preset Flow Curves

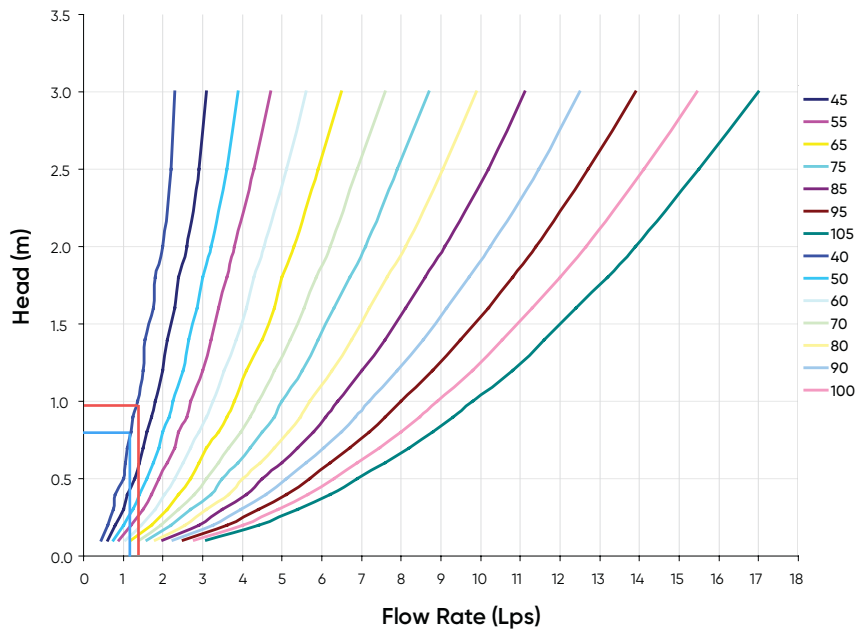

TEMPEST  
LMF ICD

Chart 2: LMF Flow vs. ICD Alternatives

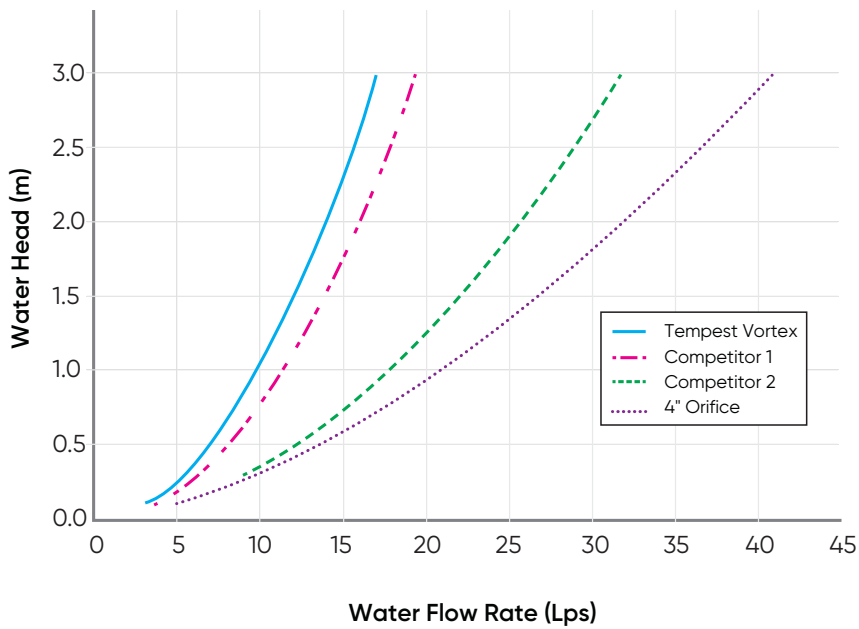

APPENDIX H  
CITY OF OTTAWA DESIGN CHECKLIST

## Parameters

Units: Metric

Storage Volume: 12 Cu m

Chamber Selection: S-29B

Header Row Position: Left

Fill Over Embedment Stone: 300 mm

Controlled By: width 3.00 m

### Embedment Stone mm:

Over: 150 Under: 150 Porosity: 0.4

Min 150mm over and under

### Double Stacked

Double Stacked?: No

Stone Between:

Note: After making an input change you must hit calculate to update the Field Diagram and Project Results.

\* The image generation will not save if using MicroSoft Edge

## Project Results

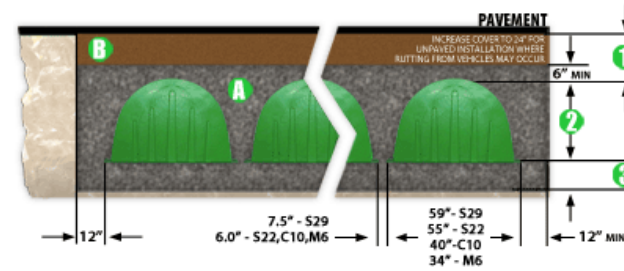

1 Total Cover Over Chambers: 301 mm

2 Height Of Chamber: 947 mm

3 Embedment Stone Under Chambers: 151 mm

A Volume of Embedment Stone Required: 17 Cu. m

B Volume of Fill Material Required: 6 Cu. m

Total Storage Provided: 14 Cu. m

Type Of Chambers: S-29B

# Of Chambers Required: 8

# Of End Caps Required: 4

Required Bed Size: 19 Sq. m

Volume of Excavation: 24 Cu. m

\* Area of Filter Fabric: 47 Sq. m

# of Chambers Long: 7

# of rows: 1

Actual Trench Length: 8.70 m

Actual Trench Width: 2.18 m

\* Filter Fabric quantity for Fabric on Top and Sides of System Only, does not include overlap

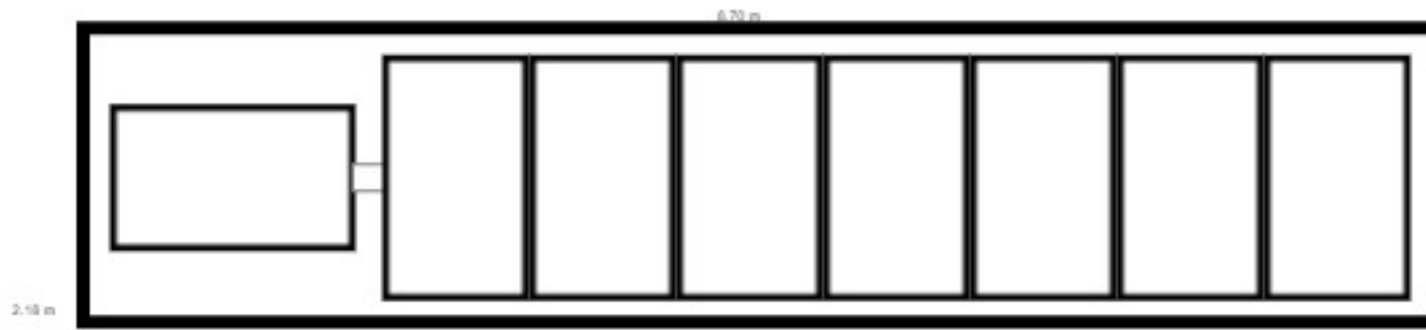

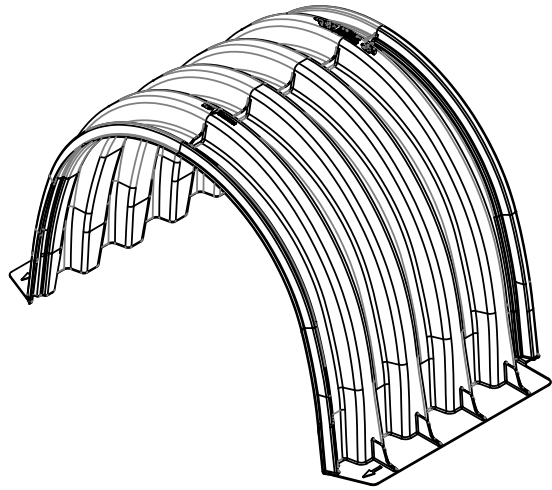

S-29-B CHAMBER SPECS	
NOMINAL DIMENSIONS (LAYUP LENGTH X WIDTH X HEIGHT)	33.35" x 61.76" x 37.27" [847mm x 1569mm x 947mm]
BARE CHAMBER STORAGE	27.80 ft <sup>3</sup> [0.787 m <sup>3</sup> ]
*MIN INSTALLED STORAGE	42.52 ft <sup>3</sup> [1.204 m <sup>3</sup> ]
CHAMBER WEIGHT	34 lbs [15.42 kg]
STORAGE PER LINEAR UNIT WITHOUT STONE	10.0 ft <sup>3</sup> /ft [0.929 m <sup>3</sup> /m]
STORAGE PER LINEAR UNIT WITH STONE	15.3 ft <sup>3</sup> /ft [1.421 m <sup>3</sup> /m]

\*ASSUMING A MIN OF 6" (152mm) STONE ABOVE AND BELOW AND 5" (127mm) BETWEEN ROWS WITH 40% STONE POROSITY (DOES NOT INCLUDE 12" (305mm) PERIMETER STONE VOLUME)

NOTE: S-29-B CHAMBER DETAILS TESTED AND RATED TO EXCEED HS-25 LOAD CONDITIONS WITH 18" (457mm) OF COVER AND NO PAVEMENT.

EACH S29-B CHAMBER HAS A TOTAL FLANGE SURFACE CONTACT AREA OF 294 IN<sup>2</sup> (1896 CM<sup>2</sup>) OR 147 IN<sup>2</sup> (948 CM<sup>2</sup>) PER FLANGE

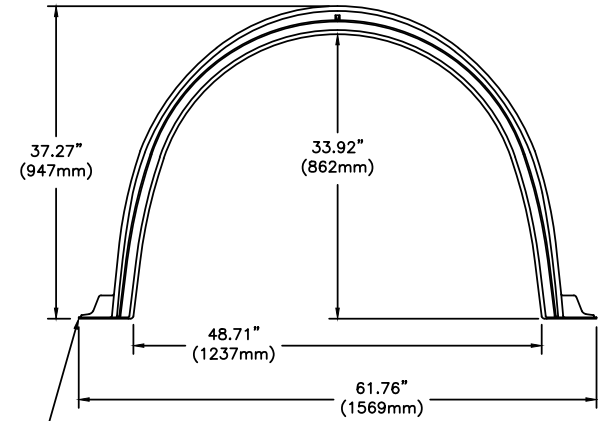

PART THICKNESS  
0.118" - 0.177"  
[3.0mm - 4.5mm]

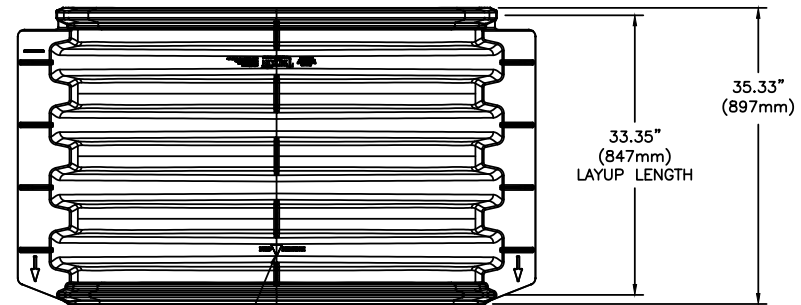
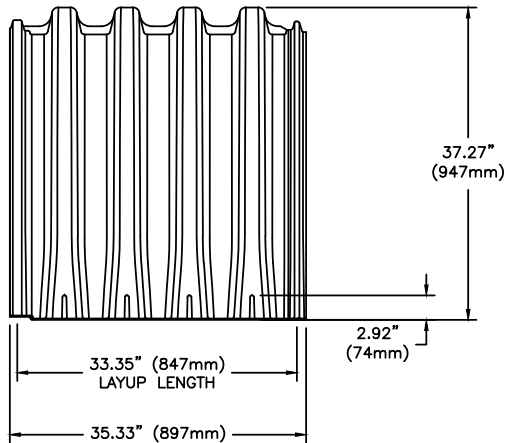

CHAMBERS TO BE INSTALLED IN THIS DIRECTION. FOLLOW DIRECTION ARROW ON THE PART.

**CONCEPTUAL PLAN DISCLAIMER**  
THIS GENERIC DETAIL DOES NOT ENCOMPASS THE SIZING, FIT, AND APPLICABILITY OF THE TRITON CHAMBER SYSTEM FOR THIS SPECIFIC PROJECT. IT IS THE ULTIMATE RESPONSIBILITY OF THE DESIGN ENGINEER TO ASSURE THAT THE STORMWATER SYSTEM DESIGN IS IN FULL COMPLIANCE WITH ALL APPLICABLE LAWS AND REGULATIONS. TRITON PRODUCTS MUST BE DESIGNED AND INSTALLED IN ACCORDANCE WITH TRITON'S MINIMUM REQUIREMENTS. TRITON STORMWATER SOLUTIONS DOES NOT APPROVE PLANS, SIZING, OR SYSTEM DESIGNS. THE DESIGN ENGINEER IS RESPONSIBLE FOR ALL DESIGN DECISIONS.



7600 EAST GRAND RIVER, STE. 195  
BRIGHTON, MI 48114  
PHONE: (810) 222-7652 • FAX: (810) 222-1769  
WWW.TRITONSW.COM

## S-29-B CHAMBER DETAIL

TRITON - STANDARD DETAILS

REVISED:

01-24-23 JWM



- CISTERN NOTES:**
1. SEE MCINTOSH PERRY EGIS STORMWATER MANAGEMENT REPORT FOR ADDITIONAL SUPPORTING INFORMATION FOR THE SYSTEM. THAT REPORT SHALL FORM PART OF THE SUPPORTING DOCUMENTS FOR THIS CONTRACT. CONTRACTOR SHALL READ THE REPORT PRIOR TO SUBMITTING CONTRACT PRICE.
  2. THIS CONTRACTOR TO PROVIDE PIPING, CONTROLS, CONDUIT, WIRING AND MECHANICAL EQUIPMENT FOR THE CISTERNS, CISTERNS TO BE PROVIDED BY GENERAL CONTRACTOR.
  3. ALL PIPING SHALL BE PRESSURE PIPING INCLUDING STORM UP TO THE 2ND FLOOR SLAB.
  4. ALL PENETRATIONS OF THE CISTERN SHALL BE MADE PRESSURE AND WATER TIGHT, AND SHALL BE MADE ABOVE THE FREE SURFACE.
  5. CONTRACTOR TO MEASURE AREA OF CISTERN AFTER IT IS FORMED AND DETERMINE HEIGHTS OF ALL WATER LEVELS, FLOAT LEVELS AND PIPE PENETRATIONS. SUBMIT FABRICATION SKETCH TO ENGINEER FOR REVIEW PRIOR TO STARTING WORK. ALL PIPE AND CONTROLS OPENINGS TO BE CORED IN THE CISTERN AFTER IT IS FORMED.

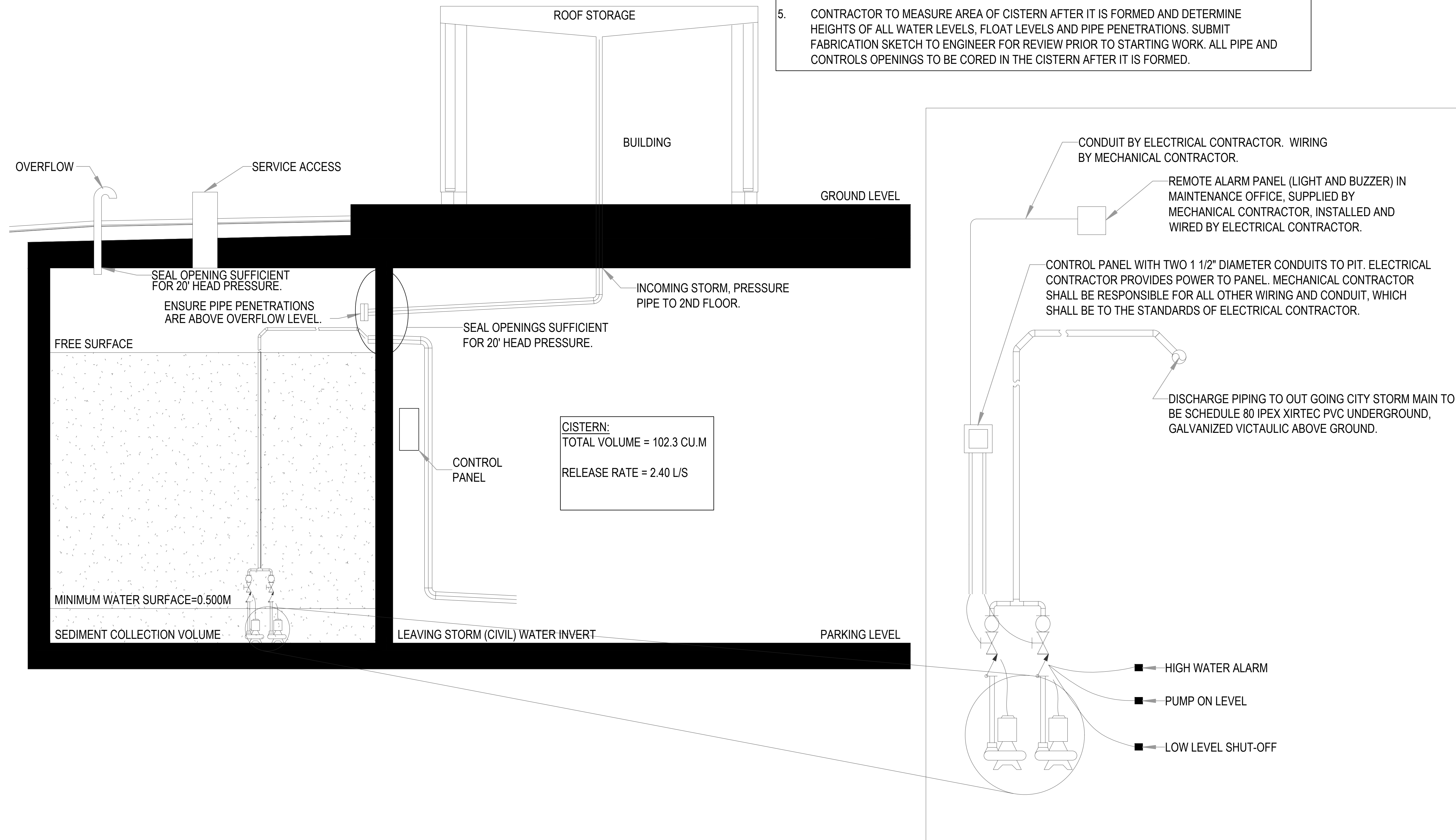

# City of Ottawa

## 4. Development Servicing Study Checklist

The following section describes the checklist of the required content of servicing studies. It is expected that the proponent will address each one of the following items for the study to be deemed complete and ready for review by City of Ottawa Infrastructure Approvals staff.

The level of required detail in the Servicing Study will increase depending on the type of application. For example, for Official Plan amendments and re-zoning applications, the main issues will be to determine the capacity requirements for the proposed change in land use and confirm this against the existing capacity constraint, and to define the solutions, phasing of works and the financing of works to address the capacity constraint. For subdivisions and site plans, the above will be required with additional detailed information supporting the servicing within the development boundary.

### 4.1 General Content

Criteria	Location (if applicable)
<input type="checkbox"/> Executive Summary (for larger reports only).	N/A
<input type="checkbox"/> Date and revision number of the report.	On Cover
<input type="checkbox"/> Location map and plan showing municipal address, boundary, and layout of proposed development.	Appendix A
<input type="checkbox"/> Plan showing the site and location of all existing services.	Site Servicing Plan (C102)
<input type="checkbox"/> Development statistics, land use, density, adherence to zoning and official plan, and reference to applicable subwatershed and watershed plans that provide context to which individual developments must adhere.	1.1 Purpose 1.2 Site Description 6.0 Stormwater Management
<input type="checkbox"/> Summary of pre-consultation meetings with City and other approval agencies.	Appendix B
<input type="checkbox"/> Reference and confirm conformance to higher level studies and reports (Master Servicing Studies, Environmental Assessments, Community Design Plans), or in the case where it is not in conformance, the proponent must provide justification and develop a defensible design criteria.	1.1 Purpose 1.2 Site Description 6.0 Stormwater Management
<input type="checkbox"/> Statement of objectives and servicing criteria.	3.0 Pre-Consultation Summary

<input type="checkbox"/> Identification of existing and proposed infrastructure available in the immediate area.	N/A
<input type="checkbox"/> Identification of Environmentally Significant Areas, watercourses and Municipal Drains potentially impacted by the proposed development (Reference can be made to the Natural Heritage Studies, if available).	Site Grading Plan (C101)
<input type="checkbox"/> Concept level master grading plan to confirm existing and proposed grades in the development. This is required to confirm the feasibility of proposed stormwater management and drainage, soil removal and fill constraints, and potential impacts to neighbouring properties. This is also required to confirm that the proposed grading will not impede existing major system flow paths.	Site Grading Plan (C101)
<input type="checkbox"/> Identification of potential impacts of proposed piped services on private services (such as wells and septic fields on adjacent lands) and mitigation required to address potential impacts.	N/A
<input type="checkbox"/> Proposed phasing of the development, if applicable.	N/A
<input type="checkbox"/> Reference to geotechnical studies and recommendations concerning servicing.	Section 2.0 Background Studies, Standards and References
<input type="checkbox"/> All preliminary and formal site plan submissions should have the following information: <ul style="list-style-type: none"> <li>○ Metric scale</li> <li>○ North arrow (including construction North)</li> <li>○ Key plan</li> <li>○ Name and contact information of applicant and property owner</li> <li>○ Property limits including bearings and dimensions</li> <li>○ Existing and proposed structures and parking areas</li> <li>○ Easements, road widening and rights-of-way</li> <li>○ Adjacent street names</li> </ul>	Site Grading Plan (C101)

## 4.2 Development Servicing Report: Water

Criteria	Location (if applicable)
<input type="checkbox"/> Confirm consistency with Master Servicing Study, if available	N/A
<input type="checkbox"/> Availability of public infrastructure to service proposed development	N/A
<input type="checkbox"/> Identification of system constraints	N/A
<input type="checkbox"/> Identify boundary conditions	Appendix C
<input type="checkbox"/> Confirmation of adequate domestic supply and pressure	N/A
<input type="checkbox"/> Confirmation of adequate fire flow protection and confirmation that fire flow is calculated as per the Fire Underwriter's Survey. Output should show available fire flow at locations throughout the development.	Appendix C
<input type="checkbox"/> Provide a check of high pressures. If pressure is found to be high, an assessment is required to confirm the application of pressure reducing valves.	N/A
<input type="checkbox"/> Definition of phasing constraints. Hydraulic modeling is required to confirm servicing for all defined phases of the project including the ultimate design	N/A
<input type="checkbox"/> Address reliability requirements such as appropriate location of shut-off valves	N/A
<input type="checkbox"/> Check on the necessity of a pressure zone boundary modification.	N/A
<input type="checkbox"/> Reference to water supply analysis to show that major infrastructure is capable of delivering sufficient water for the proposed land use. This includes data that shows that the expected demands under average day, peak hour and fire flow conditions provide water within the required pressure range	Appendix C, Section 4.2

<input type="checkbox"/> Description of the proposed water distribution network, including locations of proposed connections to the existing system, provisions for necessary looping, and appurtenances (valves, pressure reducing valves, valve chambers, and fire hydrants) including special metering provisions.	Site Servicing Plan (C101)
<input type="checkbox"/> Description of off-site required feeder mains, booster pumping stations, and other water infrastructure that will be ultimately required to service proposed development, including financing, interim facilities, and timing of implementation.	N/A
<input type="checkbox"/> Confirmation that water demands are calculated based on the City of Ottawa Design Guidelines.	Appendix C
<input type="checkbox"/> Provision of a model schematic showing the boundary conditions locations, streets, parcels, and building locations for reference.	N/A

#### 4.3 Development Servicing Report: Wastewater

Criteria	Location (if applicable)
<input type="checkbox"/> Summary of proposed design criteria (Note: Wet-weather flow criteria should not deviate from the City of Ottawa Sewer Design Guidelines. Monitored flow data from relatively new infrastructure cannot be used to justify capacity requirements for proposed infrastructure).	N/A
<input type="checkbox"/> Confirm consistency with Master Servicing Study and/or justifications for deviations.	N/A
<input type="checkbox"/> Consideration of local conditions that may contribute to extraneous flows that are higher than the recommended flows in the guidelines. This includes groundwater and soil conditions, and age and condition of sewers.	N/A
<input type="checkbox"/> Description of existing sanitary sewer available for discharge of wastewater from proposed development.	Section 5.2 Proposed Sanitary Sewer

<input type="checkbox"/> Verify available capacity in downstream sanitary sewer and/or identification of upgrades necessary to service the proposed development. (Reference can be made to previously completed Master Servicing Study if applicable)	Section 5.3 Proposed Sanitary Design
<input type="checkbox"/> Calculations related to dry-weather and wet-weather flow rates from the development in standard MOE sanitary sewer design table (Appendix 'C') format.	N/A
<input type="checkbox"/> Description of proposed sewer network including sewers, pumping stations, and forcemains.	Section 5.2 Proposed Sanitary Sewer
<input type="checkbox"/> Discussion of previously identified environmental constraints and impact on servicing (environmental constraints are related to limitations imposed on the development in order to preserve the physical condition of watercourses, vegetation, soil cover, as well as protecting against water quantity and quality).	N/A
<input type="checkbox"/> Pumping stations: impacts of proposed development on existing pumping stations or requirements for new pumping station to service development.	N/A
<input type="checkbox"/> Forcemain capacity in terms of operational redundancy, surge pressure and maximum flow velocity.	N/A
<input type="checkbox"/> Identification and implementation of the emergency overflow from sanitary pumping stations in relation to the hydraulic grade line to protect against basement flooding.	N/A
<input type="checkbox"/> Special considerations such as contamination, corrosive environment etc.	N/A

#### 4.4 Development Servicing Report: Stormwater Checklist

Criteria	Location (if applicable)
<input type="checkbox"/> Description of drainage outlets and downstream constraints including legality of outlets (i.e. municipal drain, right-of-way, watercourse, or private property)	Section 6.0 Stormwater Sewer Design & Section 7.0 Proposed Stormwater Management
<input type="checkbox"/> Analysis of available capacity in existing public infrastructure.	N/A
<input type="checkbox"/> A drawing showing the subject lands, its surroundings, the receiving watercourse, existing drainage patterns, and proposed drainage pattern.	Pre & Post-Development Plans
<input type="checkbox"/> Water quantity control objective (e.g. controlling post-development peak flows to pre-development level for storm events ranging from the 2 or 5-year event (dependent on the receiving sewer design) to 100-year return period); if other objectives are being applied, a rationale must be included with reference to hydrologic analyses of the potentially affected subwatersheds, taking into account long-term cumulative effects.	Section 6.0 Stormwater Sewer Design & Section 7.0 Proposed Stormwater Management
<input type="checkbox"/> Water Quality control objective (basic, normal or enhanced level of protection based on the sensitivities of the receiving watercourse) and storage requirements.	Section 6.0 Stormwater Sewer Design & Section 7.0 Proposed Stormwater Management
<input type="checkbox"/> Description of the stormwater management concept with facility locations and descriptions with references and supporting information.	Section 6.0 Stormwater Sewer Design & Section 7.0 Proposed Stormwater Management
<input type="checkbox"/> Set-back from private sewage disposal systems.	N/A
<input type="checkbox"/> Watercourse and hazard lands setbacks.	N/A
<input type="checkbox"/> Record of pre-consultation with the Ontario Ministry of Environment and the Conservation Authority that has jurisdiction on the affected watershed.	N/A
<input type="checkbox"/> Confirm consistency with sub-watershed and Master Servicing Study, if applicable study exists.	N/A
<input type="checkbox"/> Storage requirements (complete with calculations) and conveyance capacity for minor events (1:5-year return period) and major events (1:100-year return period).	Appendix G

<input type="checkbox"/> Identification of watercourses within the proposed development and how watercourses will be protected, or, if necessary, altered by the proposed development with applicable approvals.	Site Grading Plan
<input type="checkbox"/> Calculate pre-and post development peak flow rates including a description of existing site conditions and proposed impervious areas and drainage catchments in comparison to existing conditions.	Section 7.0 Proposed Stormwater Management Appendix G
<input type="checkbox"/> Any proposed diversion of drainage catchment areas from one outlet to another.	Section 6.0 Stormwater Sewer Design & Section 7.0 Proposed Stormwater Management
<input type="checkbox"/> Proposed minor and major systems including locations and sizes of stormwater trunk sewers, and stormwater management facilities.	Section 6.0 Stormwater Sewer Design & Section 7.0 Proposed Stormwater Management
<input type="checkbox"/> If quantity control is not proposed, demonstration that downstream system has adequate capacity for the post-development flows up to and including the 100-year return period storm event.	N/A
<input type="checkbox"/> Identification of potential impacts to receiving watercourses	N/A
<input type="checkbox"/> Identification of municipal drains and related approval requirements.	N/A
<input type="checkbox"/> Descriptions of how the conveyance and storage capacity will be achieved for the development.	Section 6.0 Stormwater Sewer Design & Section 7.0 Proposed Stormwater Management
<input type="checkbox"/> 100-year flood levels and major flow routing to protect proposed development from flooding for establishing minimum building elevations (MBE) and overall grading.	Site Grading Plan (C101)
<input type="checkbox"/> Inclusion of hydraulic analysis including hydraulic grade line elevations.	N/A



<input type="checkbox"/> Description of approach to erosion and sediment control during construction for the protection of receiving watercourse or drainage corridors.	Section 8.0 Sediment & Erosion Control
<input type="checkbox"/> Identification of floodplains – proponent to obtain relevant floodplain information from the appropriate Conservation Authority. The proponent may be required to delineate floodplain elevations to the satisfaction of the Conservation Authority if such information is not available or if information does not match current conditions.	N/A
<input type="checkbox"/> Identification of fill constraints related to floodplain and geotechnical investigation.	N/A

#### 4.5 Approval and Permit Requirements: Checklist

The Servicing Study shall provide a list of applicable permits and regulatory approvals necessary for the proposed development as well as the relevant issues affecting each approval. The approval and permitting shall include but not be limited to the following:

Criteria	Location (if applicable)
<input type="checkbox"/> Conservation Authority as the designated approval agency for modification of floodplain, potential impact on fish habitat, proposed works in or adjacent to a watercourse, cut/fill permits and Approval under Lakes and Rivers Improvement Act. The Conservation Authority is not the approval authority for the Lakes and Rivers Improvement Act. Where there are Conservation Authority regulations in place, approval under the Lakes and Rivers Improvement Act is not required, except in cases of dams as defined in the Act.	N/A
<input type="checkbox"/> Application for Certificate of Approval (CofA) under the Ontario Water Resources Act.	N/A
<input type="checkbox"/> Changes to Municipal Drains.	N/A
<input type="checkbox"/> Other permits (National Capital Commission, Parks Canada, Public Works and Government Services Canada, Ministry of Transportation etc.)	N/A

#### 4.6 Conclusion Checklist

Criteria	Location (if applicable)
<input type="checkbox"/> Clearly stated conclusions and recommendations	Section 9.0 Summary  Section 10.0 Recommendations
<input type="checkbox"/> Comments received from review agencies including the City of Ottawa and information on how the comments were addressed. Final sign-off from the responsible reviewing agency.	All are stamped
<input type="checkbox"/> All draft and final reports shall be signed and stamped by a professional Engineer registered in Ontario	All are stamped