



David Schaeffer Engineering Ltd.

120 Iber Road, Suite 103

Stittsville, ON K2S 1E9

613-836-0856

dsel.ca

DESIGN BRIEF

FOR

**BARRHAVEN CONSERVANCY
DEVELOPMENT CORPORATION**

**PROPOSED RESIDENTIAL SITE
PLAN**

CONSERVANCY STACKED TOWNS

CITY OF OTTAWA

PROJECT NO.: 24-1398

AUGUST 2024

© DSEL

**DESIGN BRIEF
FOR
PROPOSED RESIDENTIAL SITE PLAN**

BARRHAVEN CONSERVANCY DEVELOPMENT CORPORATION

PROJECT NO: 24-1398

TABLE OF CONTENTS

1.0	INTRODUCTION.....	1
1.1	Existing Conditions	1
1.2	Site Plan Layout	2
1.3	Consultation Summary.....	2
2.0	GUIDELINES, PREVIOUS STUDIES, AND REPORTS	4
2.1	Existing Studies, Guidelines, and Reports	4
3.0	WATER SUPPLY SERVICING	6
3.1	Existing Water Supply Services	6
3.2	Water Supply Servicing Design	6
3.3	Water Supply Conclusion.....	7
4.0	WASTEWATER SERVICING	8
4.1	Existing Wastewater Services	8
4.2	Wastewater Design.....	8
4.3	Wastewater Servicing Conclusions	9
5.0	STORMWATER MANAGEMENT	10
5.1	Existing Stormwater Services	10
5.2	Stormwater Management Design.....	10
5.3	Stormwater Servicing Conclusions	13
6.0	CONCLUSION AND RECOMMENDATIONS	14

DRAWINGS

Drawing 0	Title Page and Key Plan
Drawing 1	General Notes
Drawing 2	Details and Tables
Drawing 3	Details
Drawing 4	TWSI Details
Drawings 5	General Plan
Drawings 6-8	Plan and Profiles
Drawing 9	Grading Plan
Drawing 10	Cross-sections
Drawing 11	Sanitary Drainage Plan
Drawing 12	Storm Drainage Plan
Drawing 13	100-Year Static Pond Area and ICDs
Drawings 14-15	Erosion and Sediment Control Plans

TABLES

Table 1:	Development Statistics for BCDC East Condo Site Plan
Table 2:	Potential Required Permits/Approvals
Table 3:	Water Supply Design Criteria
Table 4:	Water Demand Proposed Conditions
Table 5:	Wastewater Design Criteria
Table 6:	Storm Sewer Design Criteria

APPENDICES

Appendix A	General
Appendix B	Water Supply
Appendix C	Wastewater Collection
Appendix D	Stormwater Management

**DESIGN BRIEF
FOR
PROPOSED RESIDENTIAL SITE PLAN**

BARRHAVEN CONSERVANCY DEVELOPMENT CORPORATION

**CITY OF OTTAWA
PROJECT NO: 24-1398**

1.0 INTRODUCTION

David Schaeffer Engineering Limited (DSEL) has been retained to prepare a Design Brief in support of a site plan application for the stacked townhouse condo block within Barrhaven Conservancy East on behalf of the Barrhaven Conservancy Development Corporation (BCDC).

The overall Conservancy land area is approximately 139.7 ha (all land use components) and is located within the City of Ottawa urban boundary in the Barrhaven ward. The Conservancy East development area has previously had detailed design prepared and approved with initial phases of servicing/homebuilding currently under construction. The subject site plan block is within the Conservancy East lands and is bound by the proposed townhomes fronting Les Emmerson (N) to the north, Les Emmerson (N) to the west, Conservancy Drive to the south, and Mineral Street to the east. The site plan block design (Q4 Architects Inc., August 2024) is provided in **Appendix A**.

The objective of this report is to provide sufficient detail with respect to the availability of site services to support the application of site plan control.

1.1 Existing Conditions

The **Conservancy East** lands containing the site plan block are relatively flat with the existing elevations ranging from 91.9 m in the north to 91 m in the south. All existing flows are either overland to the Jock River or conveyed to the Jock River by way of the Fraser-Clarke Watercourse (and its tributaries) and Borrisokane Road ditches which run through the subject property. The property is within the Jock River watershed and is under the jurisdiction of the RVCA.

1.2 Site Plan Layout

The proposed project consists of 10 blocks of stacked dwellings, above ground parking, walkways, and amenity space. See proposed site plan in **Appendix A**.

The predicted populations currently associated with the development concept are described in the following table below.

Table 1: Development Statistics for BCDC East Condo Site Plan

Land Use	Total Area (ha)	Projected Residential Units	Residential Population per Unit *	Projected Population
Stacked Townhouses	0.47	196	2.3	451
Parkette/Amenity	0.67			
Roads/parking/walkways	0.62			
Total	1.76	196		451

* NOTE: Population projections may differ from population estimates used in background Transportation Studies, Planning Rationale, and other studies.

1.3 Consultation Summary

Consultation with the with City of Ottawa Planning and Engineering Staff was initiated in July 2024 for the Conservancy East Stacked Condo block to review City Standards, submission requirements, and the availability of background information. The subject Site Plan was contemplated in the servicing of the Conservancy East Phase 3 & 4 subdivision area.

1.4 Required Permits / Approvals

The City of Ottawa must approve detailed engineering design drawings and reports prior to construction of the proposed infrastructure identified in this report.

The following additional approvals and permits listed in **Table 2** are expected to be required prior to construction of the municipal infrastructure detailed herein. Other permits and approvals may be required, as detailed in the other studies submitted as part of the Planning Act applications (e.g. *Tree Conservation Report, Phase 1 Environmental Site Assessment, etc.*).

Table 2: Potential Required Permits/Approvals

Agency	Permit/Approval Required	Trigger	Remarks
MECP / City of Ottawa	Environmental Compliance Approval	Construction of new sanitary & storm sewers.	MECP is expected to review the stormwater collection system and wastewater collection system by transfer of review.

DESIGN BRIEF
 BARRHAVEN CONSERVANCY DEVELOPMENT CORPORATION
 PROPOSED RESIDENTIAL SITE PLAN

MECP	Permit to Take Water	Construction of proposed land uses (e.g. basements for residential homes) and services.	Pumping of groundwater will be required during construction, given groundwater conditions and proposed land uses/ municipal infrastructure.
City of Ottawa	MOE Form 1 – Record of Watermains Authorized as a Future Alteration	Construction of watermains.	The City of Ottawa is expected to review the watermains on behalf of the MECP.

2.0 GUIDELINES, PREVIOUS STUDIES, AND REPORTS

2.1 Existing Studies, Guidelines, and Reports

The following documents were referenced in the preparation of this report:

- **Ottawa Sewer Design Guidelines,
City of Ottawa, *SDG002*, October 2012.
(*City Standards*)**
 - **Technical Bulletin ISDTB-2014-01, Revisions to Ottawa Design Guidelines – Sewer,
City of Ottawa, February 5, 2014.
(ISDTB-2014-01)**
 - **Technical Bulletin PIEDTB-2016-01, Revisions to Ottawa Design Guidelines – Sewer,
City of Ottawa, September 6, 2016.
(PIEDTB-2016-01)**
 - **Technical Bulletin ISTB-2018-01, Revisions to Ottawa Design Guidelines – Sewer,
City of Ottawa, March 21, 2018.
(ISTB-2018-01)**
 - **Technical Bulletin ISTB-2018-03, Revisions to Ottawa Design Guidelines – Sewer,
City of Ottawa, June, 2018.
(ISTB-2018-04)**
 - **Technical Bulletin ISTB-2019-02, Revisions to Ottawa Design Guidelines – Sewer,
City of Ottawa, July 8, 2019.
(ISTB-2019-02)**
- **Ottawa Design Guidelines – Water Distribution
City of Ottawa, July 2010.
(*Water Supply Guidelines*)**
 - **Technical Bulletin ISD-2010-2
City of Ottawa, December 15, 2010.
(ISD-2010-2)**
 - **Technical Bulletin ISDTB-2014-02
City of Ottawa, May 27, 2014.
(ISDTB-2014-02)**
 - **Technical Bulletin ISTB-2018-02
City of Ottawa, March 21, 2018.
(ISTB-2018-02)**

- **Technical Bulletin ISTB-2021-03
City of Ottawa, August 18, 2021
(ISTB-2021-03)**
- **Design Guidelines for Sewage Works,
Ministry of the Environment, 2008.
(MOE Design Guidelines)**
- **Stormwater Planning and Design Manual,
Ministry of the Environment, March 2003.
(SWMP Design Manual)**
- **Ontario Building Code Compendium
Ministry of Municipal Affairs and Housing Building Development Branch,
January 1, 2010 Update.
(OBC)**
- **Mississippi-Rideau Source Water Protection Plan,
MVCA & RVCA, August 2014.**
- **Erosion & Sediment Control Guidelines for Urban Construction,
Greater Golden Horseshoe Area Conservation Authorities, December 2006.**
- **Hydraulic Potable Water Assessment for Barrhaven Conservancy
Development Corporation, March 2021
(Stantec Hydraulic Analysis)**
- **Jock River Reach One Subwatershed Study
Stantec, 2007
(Jock River SWS)**
- **Geotechnical Investigation, Proposed Residential Development,
Conservancy Lands East, Ottawa, Ontario
Paterson Group, September 24, 2019 (Project No. PG5036-1)
(Geotechnical Report)**
- **Barrhaven Conservancy East (Phases 2, 3, 4 & Jock River): Water
Distribution System Analysis, Stantec, June 2, 2022
(Stantec Hydraulic Analysis - East)**
- **Adequacy of Services Report for Barrhaven Conservancy Development
Corporation, Barrhaven Conservancy East
David Schaeffer Engineering Ltd., July 2021
(DSEL East FSR)**
- **Design Brief for Barrhaven Conservancy East – Phase 2, 3, & Jock River
David Schaeffer Engineering Ltd., June 2022
(DSEL East Design Brief)**

3.0 WATER SUPPLY SERVICING

3.1 Existing Water Supply Services

The Conservancy East lands are located adjacent to the City of Ottawa’s Pressure Zone (PZ) 3SW (previously known as PZ BARR). PZ SUC services the lands that are east of the subject property, as well as south of the Jock River.

An extension of the watermain network is proposed within the Conservancy East Subdivision, which will also provide a feed for the subject site plan block. The watermains for the subdivision were designed in conjunction with the **Water Distribution System Analysis** and the **Potable Water Hydraulic Analysis Update** prepared by Stantec included in **Appendix B**.

3.2 Water Supply Servicing Design

As shown in the **General Plan**, a 300mm watermain will service the units (Blocks 3,4,7 and 10) fronting Conservancy Drive, a 150mm watermain will service units (Block 9) fronting Les Emmerson (N), and a 200mm watermain will service units (Block 1) fronting Mineral Street. The remainder of the blocks (Blocks 2, 5, 6 and 8) will be serviced via a 200mm watermain that will be looped internally within the site plan block and connect to the 200mm diameter watermain on Mineral Street and to the 300mm diameter watermain on Conservancy Drive.

The **Water Distribution System Analysis** and the **Potable Water Hydraulic Analysis Update** for the broader subdivision estimated the required fire flow was previously estimated at 217 L/s (13,000 L/min). The **Potable Water Hydraulic Analysis Update**, which included the proposed site plan demands assuming 204 units, whereas the application includes 196 units. Stantec estimated the minimum available flow within the site (Junction 92 and 93) under MXDY + FF conditions are between 14,250 to 14,486 L/min. Along Conservancy Drive (Junctions 21 and 22) between 18,499 and 18,780 L/min was estimated to be available. The analysis by Stantec concludes that adequate water pressures are available under all scenarios highlighted in **Table 3**.

Table 3: Water Supply Design Criteria

Design Parameter	Value
Extracted from Section 4: Ottawa Design Guidelines, Water Distribution (July 2010)	
Residential – Detached Single	2.3 p/unit
Minimum Watermain Size	150 mm diameter
Minimum Depth of Cover	2.4 m from top of watermain to finished grade
During normal operating conditions desired operating pressure is within	350 kPa and 480kPa
During fire flow operating pressure must not drop below	140 kPa
Stantec Hydraulic Analysis, Stantec, June 2022 for Population Exceeding 3000 Persons	
Residential – SFH, MLT	280 L/cap/day
Residential – Average Day Demand	Population x Demand
Residential – Max Day Demand	AVDY x 2.5

Residential – Peak Hour Demand	MXDY x 2.2
Fire Flow Requirement	13,000 L/min

Table 4 summarizes the estimated water supply demands seen in **Appendix B** for the proposed site plan based on the **Water Supply Guidelines**. Fire flows were estimated for blocks 1, 4, 5, and 9. Block 4 yielded the highest required fire flow of 15,000L/min, which has frontage on Conservancy Drive where flow in excess of 18,000L/min is available.

Table 4: Water Demand Proposed Conditions

Design Parameter	Estimated Demand ¹ (L/min)	Boundary Condition (m H ₂ O / kPa)
Average Daily Demand	87.7	
Max Day + Fire Flow	254.3 + 15,000= 15,254.3	
Peak Hour	377.1	
1) Water demand calculation per Water Supply Guidelines . See Appendix B for detailed calculations.		

3.3 Water Supply Conclusion

In summary, Blocks 3,4,7 and 10 fronting Conservancy Drive, Block 9 fronting Les Emmerson (N), and Block 1 fronting Mineral Street will all be serviced with connections to the public right of way. The remainder of the site plan blocks will be serviced internally and ultimately be looped back to the subdivision. The system has been reviewed for required domestic demand and fire flows and meet all necessary requirements.

4.0 WASTEWATER SERVICING

4.1 Existing Wastewater Services

The subject site was considered in the design of the Barrhaven Conservancy East Subdivision and will drain to the the existing SNC sanitary sewer which serves as the ultimate outlet for the overall development. Please refer to the **Sanitary Drainage Plan** prepared by DSEL, included in **Appendix C**.

4.2 Wastewater Design

The site plan blocks fronting the Les Emmerson Drive (N), Conservancy Drive, and Mineral Street will connect directly to the sanitary sewers within the public ROW with one lateral servicing two units (upper and lower). The internal sanitary sewer layout within the site plan will consist of a 200mm PVC sanitary sewer that will follow Street 1 and 2, connecting to Conservancy Drive (MH23A) at the south and Mineral Street (MH46A) at the east. Internally, one lateral will service two units (upper and lower).

The site was originally assumed to have a population of 470 during the subdivision design. However, the estimated population of the proposed subdivision is now lower (451 persons) given updates to the proposed number of units, and as such total flows to the existing SNC sanitary sewer will be marginally reduced.

Table 5 below summarizes the design standards used in the development of the proposed wastewater sewer system for the Barrhaven Conservancy East Subdivision. The sanitary calculation sheets have been updated to reflect the revised population and are included in **Appendix C**.

Table 5: Wastewater Design Criteria

Design Parameter	Value
Current Design Guidelines	
Residential – Stacked TH Condo	2.3 p/unit
Average Daily Demand	280 L/d/person
Peaking Factor	Harmon’s Peaking Factor. Max 4.0, Min 2.0
Commercial / Institutional Flows	28,000 L/ha/day
Commercial / Institutional Peak Factor	1.5
Infiltration and Inflow Allowance	0.33 L/s/ha
Park Flows	28,000 L/ha/d
Park Peaking Factor	1.0
Sanitary sewers are to be sized employing the Manning’s Equation	$Q = \frac{1}{n} AR^{2/3} S^{1/2}$
Minimum Sewer Size	200mm diameter
Minimum Manning’s ‘n’	0.013
Minimum Depth of Cover	2.5m from crown of sewer to grade
Minimum Full Flowing Velocity	0.6m/s
Maximum Full Flowing Velocity	3.0m/s
<i>Extracted from Sections 4 and 6 of the City of Ottawa Sewer Design Guidelines, October 2012, and associated Technical Bulletins.</i>	

4.3 Wastewater Servicing Conclusions

The subject property will be serviced by local sanitary sewers which will outlet to the existing infrastructure. The subject site has been contemplated in the downstream sewers. Sufficient capacity exists to support the development.

5.0 STORMWATER MANAGEMENT

5.1 Existing Stormwater Services

As discussed in the **Serviceability in Support of Draft Plan Updates Memo (DSEL, 2024)**, the development of the site plan block was considered in the functional subdivision design.

5.2 Stormwater Management Design

The Barrhaven Conservancy East Subdivision Phase 3 & 4 functional design made the following assumptions regarding the proposed site plan block:

- The site plan block has a drainage area of approximately 1.90 hectares with 86% imperviousness.
- As modeled in the **April 2024 Preliminary HGL Analysis (Phase 3 & 4 FSR Submission)**, the site plan block has a drainage split and the minor system is serviced by MH704 at Les Emmerson Drive (N) and by MH507 on Mineral Street. All flows are ultimately conveyed to the downstream OGS units (OGS 5, 6 and 7), with no on-site storage considered.
- Excess major system flows drain east and west overland to Les Emmerson Drive (N) and Mineral Street and subsequently to the Jock River.
- Quality and erosion control treatment for the site plan block is considered in the design of the treatment train approach.
- The 100-year Chicago 3 Hour Event & 5-year Jock River Water Level results in a Hydraulic Grade Line (HGL) at MH-504 and MH-505 of 92.98 m and 92.85 m, respectively.

On-site storm flows will be captured by local CB infrastructure within the parking areas. **Table 6** below summarizes the design standards used for the proposed on-site storm sewer system. Storm calculation sheets for the subject property have been appended to this technical brief in **Appendix D**.

Table 6: Storm Sewer Design Criteria

Design Parameter	Value
Minor System Design Return Period	1:2 year (PIEDTB-2016-01) for private roads, without ponding
Major System Design Return Period	1:100 year
Intensity Duration Frequency Curve (IDF) 2-year storm event: A=732.951 B=6.199 C=0.810 5-year storm event: A = 998.071 B = 6.053 C = 0.814	$i = \frac{A}{(t_c + B)^C}$
Minimum Time of Concentration	10 minutes
Rational Method	$Q = CiA$
Storm sewers are to be sized employing the Manning's Equation	$Q = \frac{1}{n} AR^{2/3} S^{1/2}$

Runoff coefficient for paved and roof areas	0.9
Runoff coefficient for landscaped areas	0.2
Minimum Sewer Size	250 mm diameter
Minimum Manning's 'n' for pipe flow	0.013
Minimum Depth of Cover	1.5 m from crown of sewer to grade
Minimum Full Flowing Velocity	0.8 m/s
Maximum Full Flowing Velocity	6.0 m/s
Clearance from 100-Year Hydraulic Grade Line to Building Opening	0.30 m
Design Parameter	Value
Max. Allowable Flow Depth on Municipal Roads	35 cm above gutter (PIEDTB-2016-01)
Extent of Major System	To be contained within the private road and parking areas or adjacent to the ROW provided that the water level must not touch any part of the building envelope and must remain below the lowest building opening during the stress test event (100-year + 20%) and 15cm vertical clearance is maintained between spill elevation on the street and the ground elevation at the nearest building envelope (PIEDTB-2016-01)
Stormwater Management Model	PCSWMM (version 7.4) – See JFSA report File No. 1474(03) in Appx D
Model Parameters	Fo = 76.2 mm/hr, Fc = 13.2 mm/hr, DCAY = 4.14/hr, D.Stor.Imp. = 1.57 mm, D.Stor.Per. = 4.67 mm
Imperviousness	Based on runoff coefficient (C) where Percent Imperviousness = (C - 0.2) / 0.7 x 100%.
Design Storms	Chicago 3-hour Design Storms and 24-hour SCS Type II Design Storms. Maximum intensity averaged over 10 minutes.
Historical Events	July 1st, 1979, August 4th, 1988 and August 8th, 1996
Climate Change Street Test	20% increase in the 100-year, 3-hour Chicago storm
<i>Extracted from City of Ottawa Sewer Design Guidelines, October 2012, and ISSU, and based on recent residential subdivisions in City of Ottawa.</i>	

5.3 Hydraulic Grade Line Analysis

A detailed hydraulic grade line (HGL) modelling analysis has been completed for the proposed system based on the 100-year 3-hour Chicago, 12-hour SCS, and 24-hour SCS design storms,

including historical design storms and climate change stress test as required. The HGL and freeboard clearances are tabled in **Appendix D** for reference.

5.4 Major System Design

Major system conveyance, or overland flow (OLF), is provided to accommodate flows in excess of the minor system capacity. OLF is accommodated by generally storing stormwater up to the 100-year design event in road sags then routing additional surface flow along the road network and rear yards storm retention tank between Private Street 1 and Private Street 6, as shown in the *Storm Drainage Plans*.

5.5 Grading and Drainage Design

The following additional grading criteria and guidelines are applied to detailed design, per City of **Ottawa Guidelines** and standard industry practices:

- Slope in grassed areas will be between 2% and 7%;
- Grades in excess of 7% will require terracing to a maximum of a 3:1 slope;
- Swales are to be 0.15m deep with 3:1 side slopes unless otherwise indicated on the drawings; and,
- Perforated pipe will be required for drainage swales if they are less than 1.5% in slope;
- Grades within the roads and parking stalls are limited to min 1% and max 5%.

Drawings 19 and 20 illustrate the proposed detailed grading. External areas north of the development will be captured by the proposed system in the interim condition. It is expected that once those parcels are redeveloped, stormwater will be attenuated on-site and directed toward Innes Road per City Standards. Where required, External lands to the east will be conveyed around the development in a cut of swale.

5.6 Quality Controls

The subject lands are required to provide quality controls prior to directing stormwater to the municipal sewers and ultimately the Jock River. Quality control is provided through a treatment train system including CB Shields, deep sump catch basins, and infiltration chambers. The treatment train system is tributary to a downstream Oil Grit Separator sized with consideration for the subsection lands.

DSEL reviewed tributary areas and associated percent imperviousness to the receiving OGS units (OGS 5, 6 and 7). **Appendix D** contains an overall figure illustrating tributary areas and corresponding OGS sizing.

It is proposed to provide infiltration through ADS Stormtech Chambers at strategic locations throughout the site. **Appendix D** contains preliminary layouts provided by the manufacturer which have been incorporate into the design plans.

Appendix D contains detailed description and calculations demonstrating that 80% TSS removal will be achieved through the treatment train system.

5.7 Stormwater Servicing Conclusions

The SWM design for the site plan block assumes that all flow is directed to the Jock River, with on-site infiltration, deep sump catch basins, and CB shields in conformance with the overall development treatment train approach for water quality control.

6.0 EROSION AND SEDIMENT CONTROL

Soil erosion occurs naturally and is a function of soil type, climate and topography. The extent of erosion losses is exaggerated during construction where vegetation has been removed and the top layer of soil becomes agitated. Prior to topsoil stripping, earthworks or construction, erosion and sediment controls will be implemented and will be maintained throughout construction.

Silt fencing will be installed around the perimeter of the active part of the site (and headwater features) and will be cleaned and maintained throughout construction. The silt fence will remain in place until the working areas have been stabilized and re-vegetated.

Catchbasins will have catchbasin inserts installed during construction to protect from silt entering the storm sewer system.

A mud mat will be installed at the construction access to prevent mud tracking onto adjacent roads.

The following additional recommendations to the Contractor will be included in contract documents:

- Limit extent of exposed soils at any given time.
- Re-vegetate exposed areas as soon as possible.
- Minimize the area to be cleared and grubbed.
- Protect exposed slopes with plastic or synthetic mulches.
- Install silt fence to prevent sediment from entering any existing ditches.
- No refueling or cleaning of equipment near existing watercourses.
- Provide sediment traps and basins during dewatering.

The Contractor will be required to complete regular inspections and guarantee proper performance. The inspection is to include:

- Verification that water is not flowing under silt barriers.
- Clean and change inserts at catch basins.

7.0 CONCLUSION AND RECOMMENDATIONS

David Schaeffer Engineering Ltd. (DSEL) has been retained by BCDC to prepare a Design Brief in support of their application for site plan control. The preceding report outlines the following:

- Water – surrounding water main infrastructure within the Conservancy East Subdivision is available to support the subject lands. Sufficient pressure is available within the City’s desired pressure range.
- Wastewater – Sanitary sewers within the development have been proposed or are under construction. The sanitary sewer network will be available and have capacity to support the site plan block.
- Stormwater – Storm servicing was previously considered in the design of the receiving sewers and downstream OGS units. The subject property consists of a series of gravity sewers servicing the landscape and parking lot areas. Runoff from the development will be treated by CB shields, deep sump CBs, and OGS units prior to outletting to the Jock River.

The submitted materials demonstrate that the water, sanitary, and storm services currently proposed and/ or under construction can accommodate the contemplated development.

Prepared by
David Schaeffer Engineering Ltd.

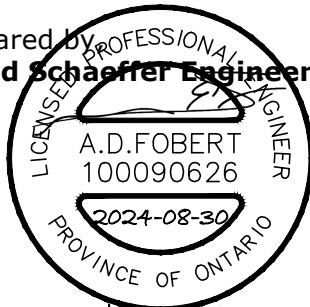

Per: Adam D. Fobert, P.Eng.
© DSEL



David Schaeffer Engineering Ltd.

120 Iber Road, Suite 103

Stittsville, ON K2S 1E9

613-836-0856

dsel.ca

APPENDIX A

SITE AREA	17,615.32 m ² (4.52 ha)
PAVED AREA	6,217.3689 m ² (35.29%)
LANDSCAPED AREA	6,713.7186 m ² (38.1%)
TOTAL BUILDING COVERAGE	4,684.2325 m ² (26.6%)
TOTAL GROSS FLOOR AREA	17,617.3808 m ²
DENSITY (UPH)	
ZONE CATEGORY	R4(Z)

DWELLING BLOCK	DWELLING TYPE	GROSS FLOOR AREA (m ²)	UNITS
BLOCKS 4 - 7 - 8 - 10	24 UNITS STACKED DWELLING		96
BLOCKS 5 - 6	20 UNITS STACKED DWELLING		40
BLOCKS 1 - 2 - 3	16 UNITS STACKED DWELLING		48
BLOCKS 9	12 UNITS STACKED DWELLING		12
	TOTAL		196

ZONE PROVISION - PLANNED UNIT DEVELOPMENT	REQUIRED	PROPOSED
162A(Z) Min. Lot Area (m ²)	1,400 m ²	1,400 m ²
162A(Z) Min. Lot Width (m)	18	18
162A(Z) Min. Front Yard Setback (m)	3	3
162B.6 Min. Interior Side Yard Setback	3	3
162B.6 Min. Rear yard setback (m)	6	4.5
162A(Z) Max Building Height (m)	14.5	14.5
131.1 Landscaped Area	30%	30%
131.1a Min. Width of Private Way / Parking Aisle (m)	6	6.1
131.2a Min. Setback for Any Wall of a Residential Building Within a Planned Unit Development	1.2	1.2
131.2 Min. setback for any wall of a residential use building to a private way	1.8	1.8
137 AMENITY AREA		
137.6 Total min. amenity area (6m ² per unit)	1176	1176
137.6 Min. communal Amenity Area m ² (Min. 50% area)	588	588
65.5 LIMITED PROJECTION INTO REQUIRED YARDS		
65.5.1 Fire escapes, Open Stairways, Stoop (m)	>0.6m to lot line	0
65.6.a(i) Covered or Uncovered Balcony, Porch and Deck		2m no closer than 1

PARKING REQUIREMENTS	REQUIRED	PROPOSED
101 (Table R10) Resident Parking - 1.2 spaces/unit	235	198 (1.0)
102 (Table column III) Visitor Parking - 0.2 spaces/unit	39	19 (0.1)
106.1 Min. Perpendicular Parking Space Size (m)	2.6 x 5.2	2.6 x 5.2
107 (Table 107.d) Min. Requires Aisle Width	6.7	6.1
Traffic and Parking Bylaw Section 111		
111 Min. Barrier Free Parking	1	1
111 BICYCLE STORAGE		
111B Min. bicycle parking space dimension, horizontal (m)	Width: 0.6m Length: 1.8m	0.6 1.8
111A(b) Min. bicycle parking space access aisle Width (m)	1.5	1.5
111.1 Min. Bicycle Parking 0.5 spaces/unit	98	98
110(a)(d) LANDSCAPED AREA SURROUNDING PARKING LOT		
110.a Abutting a Street (m)	3	n/a
110.b Not Abutting a street (m)	1.5	1.5
110.1.b Min. % of parking lot landscape	15%	15
110 REUSE COLLECTION AREAS		
110.3b Min. Waste collection setback to lot line	3	3
110.3.c/d Opaque Screen Min. Height (m)	2	2***

***Section 110.3(d) where an in-ground refuse container is provided, the screening requirement of Section 110.3(c) above may be achieved with soft landscaping (Bylaw 2020.29)

GARBAGE: REQUESTED BY ZONING: PH X
 GARBAGE: 0.231 CUBIC YARD /UNIT 0.231 X 196 = 45.27 CUBIC YARD (7 BINS)
 RECYCLING 0.062 CUBIC YARD /UNIT 0.018 X 196 = 0.54 CUBIC YARDS (1 BIN)
 + 0.062 CUBIC YARD /UNIT 0.062 X 196 = 12.15 CUBIC YARDS (2 BINS)
 ORGANIC 240L PER 50 UNITS 240 L X 3.92 = 940 L (1 BIN)
 TOTAL BINS = 11 BINS

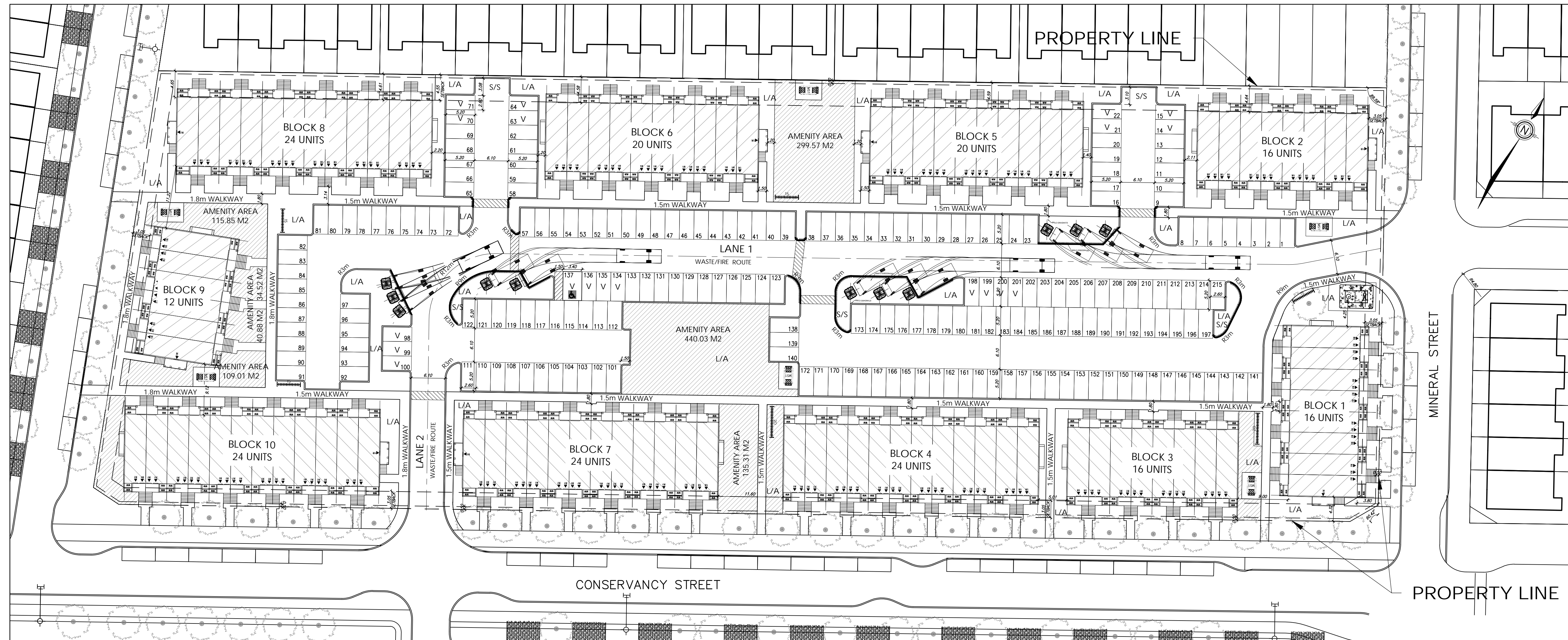

Q4 ARCHITECTS INC.

4110 YONGE STREET
 Suite 602, Toronto ON,
 M2P 2B7

T. 416.322.6334
 F. 416.322.7294
 E. info@q4architects.com

The contractor / builder must verify all dimensions on the job and report any discrepancy to the designer before proceeding with the work.

Drawings are NOT to be scaled. All drawings and specifications are instruments of service and the copyright, property of the designer and must be returned upon request.

Q4 Architects Inc. retains the copyright in all drawings, plans, sketches, and all digital information. They may not be copied or used for any other projects or purposes or distributed without the written consent of Q4 Architects Inc.

NO.	REVISION	DATE
9	ADDITIONAL COMMENTS ISSUED TO CLIENT	2024.08.26
8	ADDITIONAL COMMENTS ISSUED TO CLIENT	2024.08.16
7	ADDITIONAL COMMENTS ISSUED TO CLIENT	2024.08.04
6	ADDITIONAL SITE STATS ISSUED TO CLIENT	2024.07.25
5	REVISED AS PER CITY AND CLIENT COMMENTS	2024.07.17
4	REVISED GARBAGE LAYOUT	2024.07.16
3	SPI-2 AFTER CITY'S COMMENTS	2024.07.15
2	ADD HYDRO TRANSFORMER	2024.07.02
1	Q4A SPI	2024.06.27

Issued / Revision Chart

CONSERVANCY STACKED TOWNS OTTAWA, ON.

Location

Client **CAIVAN**

Project No.

Scale **1:500**

Drawn By **CT**

Checked By **CT**

OVERALL SITE PLAN



David Schaeffer Engineering Ltd.

120 Iber Road, Suite 103

Stittsville, ON K2S 1E9

613-836-0856

dsel.ca

APPENDIX B

Water Demand Design Flows per Unit Count
City of Ottawa - Water Distribution Guidelines, July 2010



Domestic Demand

Type of Housing	Per / Unit	Units	Pop
Single Family	3.4	-	0
Semi-detached	2.7	-	0
Stack Townhouse	2.3	196	451
Apartment			0
Bachelor	1.4	-	0
1 Bedroom	1.4	-	0
2 Bedroom	2.1	-	0
3 Bedroom	3.1	-	0
Average	1.8	-	0

	Pop	Avg. Daily		Max Day		Peak Hour	
		m ³ /d	L/min	m ³ /d	L/min	m ³ /d	L/min
Total Domestic Demand	451	126.3	87.7	366.2	254.3	543.0	377.1

Institutional / Commercial / Industrial Demand

Property Type	Unit Rate	Units	Avg. Daily		Max Day		Peak Hour	
			m ³ /d	L/min	m ³ /d	L/min	m ³ /d	L/min
Commercial floor space	2.5 L/m ² /d	-	0.00	0.0	0.0	0.0	0.0	0.0
Office	75 L/9.3m ² /d	-	0.00	0.0	0.0	0.0	0.0	0.0
Restaurant*	125 L/seat/d	-	0.00	0.0	0.0	0.0	0.0	0.0
Industrial - Light	35,000 L/gross ha/d	-	0.00	0.0	0.0	0.0	0.0	0.0
Industrial - Heavy	55,000 L/gross ha/d	-	0.00	0.0	0.0	0.0	0.0	0.0
Total I/CI Demand			0.0	0.0	0.0	0.0	0.0	0.0
Total Demand			126.3	87.7	366.2	254.3	543.0	377.1

* Estimated number of seats at 1seat per 9.3m²



Fire Flow Estimation per Fire Underwriters Survey

Water Supply For Public Fire Protection - 2020

Fire Flow Required

1. Base Requirement

$$F = 220C\sqrt{A}$$

L/min

Where *F* is the fire flow, *C* is the Type of construction and *A* is the Total floor area

Type of Construction:

Wood Frame

C 1.5 Type of Construction Coefficient per FUS Part II, Section 1
A 1134.4 m² Total floor area based on FUS Part II section 1

Fire Flow 11114.7 L/min
11000.0 L/min rounded to the nearest 1,000 L/min

Adjustments

2. Reduction for Occupancy Type

Limited Combustible -15%

Fire Flow 9350.0 L/min

3. Reduction for Sprinkler Protection

Non-Sprinklered 0%

Reduction 0 L/min

4. Increase for Separation Distance

Cons. of Exposed Wall	S.D	Lw	Ha	LH	EC	
N Type V	20.1m-30m	12.5		3	38	2%
S Type V	Over 30m	12.5		3	38	0%
E Type V	20.1m-30m	30.8		3	93	8%
W Type V	3.1m-10m	12.5		3	38	16%
% Increase						26% value not to exceed 75%

Increase 2431.0 L/min

Lw = Length of the Exposed Wall
 Ha = number of storeys of the adjacent structure. Max 5 stories
 LH = Length-height factor of exposed wall. Value rounded up.
 EC = Exposure Charge

Total Fire Flow

Fire Flow 11781.0 L/min
12000.0 L/min rounded to the nearest 1,000 L/min

Notes:
 -Type of construction, Occupancy Type and Sprinkler Protection information provided by _____.
 -Calculations based on 2020 FUS



Fire Flow Estimation per Fire Underwriters Survey

Water Supply For Public Fire Protection - 2020

Fire Flow Required

1. Base Requirement

$$F = 220C\sqrt{A}$$

L/min Where *F* is the fire flow, *C* is the Type of construction and *A* is the Total floor area

Type of Construction: **Wood Frame**

C 1.5 Type of Construction Coefficient per FUS Part II, Section 1
A 1701.6 m² Total floor area based on FUS Part II section 1

Fire Flow	13612.6 L/min
	14000.0 L/min rounded to the nearest 1,000 L/min

Adjustments

2. Reduction for Occupancy Type

Limited Combustible -15%

Fire Flow	11900.0 L/min
------------------	----------------------

3. Reduction for Sprinkler Protection

Non-Sprinklered 0%

Reduction	0 L/min
------------------	----------------

4. Increase for Separation Distance

Cons. of Exposed Wall	S.D	Lw	Ha	LH	EC	
N Type V	Over 30m	30.8		3	93	0%
S Type V	Over 30m	30.8		3	93	0%
E Type V	3.1m-10m	12.5		3	38	16%
W Type V	10.1m-20m	12.5		3	38	11%
	% Increase				27%	value not to exceed 75%

Increase	3213.0 L/min
-----------------	---------------------

Lw = Length of the Exposed Wall
 Ha = number of storeys of the adjacent structure. Max 5 stories
 LH = Length-height factor of exposed wall. Value rounded up.
 EC = Exposure Charge

Total Fire Flow

Fire Flow	15113.0 L/min
	15000.0 L/min rounded to the nearest 1,000 L/min

- Notes:**
 -Type of construction, Occupancy Type and Sprinkler Protection information provided by _____.
 -Calculations based on 2020 FUS



Fire Flow Estimation per Fire Underwriters Survey

Water Supply For Public Fire Protection - 2020

Fire Flow Required

1. Base Requirement

$$F = 220C\sqrt{A}$$

L/min Where *F* is the fire flow, *C* is the Type of construction and *A* is the Total floor area

Type of Construction: **Wood Frame**

C 1.5 Type of Construction Coefficient per FUS Part II, Section 1
A 1418.0 m² Total floor area based on FUS Part II section 1

Fire Flow 12426.6 L/min
12000.0 L/min rounded to the nearest 1,000 L/min

Adjustments

2. Reduction for Occupancy Type

Limited Combustible -15%

Fire Flow 10200.0 L/min

3. Reduction for Sprinkler Protection

Non-Sprinklered 0%

Reduction 0 L/min

4. Increase for Separation Distance

Cons. of Exposed Wall	S.D	Lw	Ha	LH	EC	
N Type V	3.1m-10m	35.3		3	106	20%
S Type V	Over 30m	38.4		3	116	0%
E Type V	20.1m-30m	12.5		3	38	2%
W Type V	10.1m-20m	12.5		3	38	11%
% Increase						33% value not to exceed 75%

Increase 3366.0 L/min

Lw = Length of the Exposed Wall
 Ha = number of storeys of the adjacent structure. Max 5 stories
 LH = Length-height factor of exposed wall. Value rounded up.
 EC = Exposure Charge

Total Fire Flow

Fire Flow 13566.0 L/min
14000.0 L/min rounded to the nearest 1,000 L/min

Notes:
 -Type of construction, Occupancy Type and Sprinkler Protection information provided by _____.
 -Calculations based on 2020 FUS



Fire Flow Estimation per Fire Underwriters Survey

Water Supply For Public Fire Protection - 2020

Fire Flow Required

1. Base Requirement

$$F = 220C\sqrt{A}$$

L/min

Where *F* is the fire flow, *C* is the Type of construction and *A* is the Total floor area

Type of Construction:

Wood Frame

C 1.5 Type of Construction Coefficient per FUS Part II, Section 1
A 850.8 m² Total floor area based on FUS Part II section 1

Fire Flow 9625.6 L/min
10000.0 L/min rounded to the nearest 1,000 L/min

Adjustments

2. Reduction for Occupancy Type

Limited Combustible -15%

Fire Flow 8500.0 L/min

3. Reduction for Sprinkler Protection

Non-Sprinklered 0%

Reduction 0 L/min

4. Increase for Separation Distance

Cons. of Exposed Wall	S.D	Lw	Ha	LH	EC	
N Type V	10.1m-20m	10.1		3	31	11%
S Type V	3.1m-10m	12.6		3	38	16%
E Type V	Over 30m	23		3	69	0%
W Type V	20.1m-30m	19.9		3	60	4%
% Increase						31% value not to exceed 75%

Increase 2635.0 L/min

Lw = Length of the Exposed Wall
Ha = number of storeys of the adjacent structure. Max 5 stories
LH = Length-height factor of exposed wall. Value rounded up.
EC = Exposure Charge

Total Fire Flow

Fire Flow 11135.0 L/min
11000.0 L/min rounded to the nearest 1,000 L/min

Notes:

- Type of construction, Occupancy Type and Sprinkler Protection information provided by _____.
- Calculations based on 2020 FUS

To: Daniel Rokin
Caivan

From: Hamidreza Mohabbat
Alexandre Mineault-Guitard

Project/File: 163401964

Date: Stantec Consulting Ltd.
June 24, 2024

Reference: Barrhaven Conservancy East Potable Water Hydraulic Analysis Update

1 Overview

Barrhaven Conservancy Development Corporation (BCDC) are advancing the functional design for Caivan's Barrhaven Conservancy East Development Phases 3 and 4. The proposed development is located in the City of Ottawa (City) southwestern suburban neighbourhood of Barrhaven. The development lands are situated between Strandherd Dr. to the north, the Jock River to the south, Fraser-Clark Drain to the east, and Borrisokane Rd. to the west (see **Figure 1**).

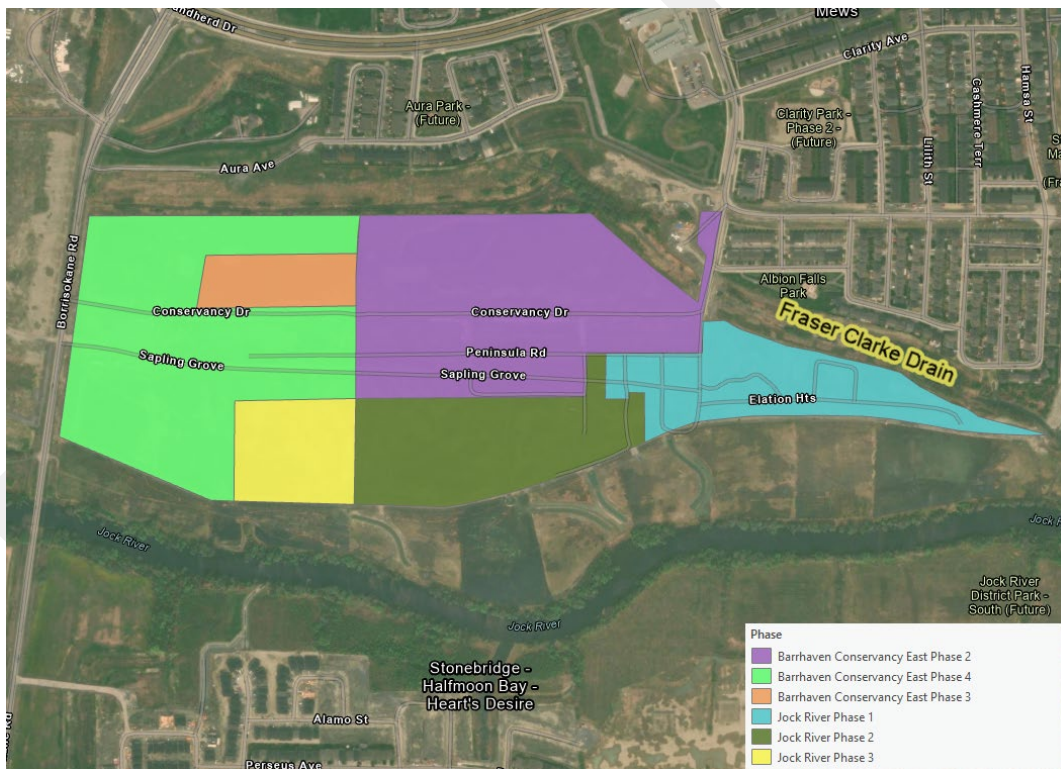

Figure 1: Barrhaven Conservancy East Development Phasing

Reference: Barrhaven Conservancy East Phasing Update Hydraulic Model

Stantec Consulting Ltd. (Stantec) previously completed the Barrhaven Conservancy East Water Distribution System Analysis report in June 2022 in support of David Schaeffer Engineering Limited (DSEL)'s update to the Servicing Design Brief for the subject lands. Stantec's June 2022 report investigated the potable water system hydraulic performance based on the proposed phasing plan, dated October 13, 2021, which included a portion of land west of Borrisokane Road.

To support DSEL with their functional design for Phases 3 and 4 of the Barrhaven Conservancy East Development, Stantec assessed the impacts of the proposed revised unit densities, serviceable population, and water demands on the potable water system. Additionally, the changes in unit counts, and associated water demands from what was previously considered in Stantec's June 2022 Report have been summarized.

For this analysis, the following phases are considered as part of the Barrhaven Conservancy East lands;

- Barrhaven Conservancy East Phase 2
- Barrhaven Conservancy East Phase 3
- Barrhaven Conservancy East Phase 4
- Jock River Phases 1 to 3

Stantec coordinated the updated water demands with the City to obtain updated boundary conditions (hydraulic grade line) at the proposed connections to the City's water network. Using such data, Stantec updated the water system hydraulic model to confirm adequate servicing for the proposed development lands against the City of Ottawa's water system hydraulic performance criteria and guidelines. This memorandum summarises the hydraulic analysis update in support of functional design of the Barrhaven Conservancy East Development Phases 3 and 4.

1.1 Concept Plan Layout, Growth Projection, Water Demands

Caivan proposed a series of updates to the development phasing, road alignments, and unit densities. **Appendix A1** depicts the proposed updated concept plan along with proposed phasing. The residential population was thereby updated based on the household sizes as per population densities (or persons per unit, PPU) specified in the City's Water Design Guidelines. Based on the updated concept plan, the total number of units is estimated to be 1,272 (527 SFH and 745 MTL), with a total residential population of 3,803 (see **Table 1** for estimated unit counts, population and water demands and **Appendix A1** for Concept Plan).

The City's Water Design Guidelines refer to the MECP Guidelines for consumption rates for buildout population greater than 3,000. The City's Water Design Guidelines consumption rates for subdivisions of 501 to 3,000 persons was used in calculation of water demands (i.e., 280 L/cap/day). Using demand rates and peaking factors from the Water Design Guidelines and Technical Bulletin ISTB-2021-03, the average day (AVDY), maximum day (MXDY) and peak-hour (PKHR) demands for each phase can be calculated.

Based on the proposed phasing and unit count updates, the population of the development area, at the completion of all phases, is estimated to be 3,803 (see **Table 1**). The corresponding demands are calculated as:

- AVDY: 12.33 L/s
- MXDY: 30.81 L/s
- PKHR: 67.79 L/s

Reference: Barrhaven Conservancy East Phasing Update Hydraulic Model

Table 1: Estimated Unit Counts, Populations, Water Demands Based on Updated Concept Plan

Phase	Unit Types	Units	PPU	Population	AVDY (L/s)	MXDY (L/s)	PKHR (L/s)
Barrhaven Conservancy East 2	Singles	204	3.4	694	2.25	12.36	12.36
	Towns	140	2.7	378	1.23	6.74	6.74
Phase 2 Sub-total		344	-	1,072	3.47	8.68	19.10
Barrhaven Conservancy East 3	Singles	0	3.4	-	-	-	-
	Towns	204	2.7	551	1.79	9.82	9.82
Phase 3 Sub-total		204	-	551	1.79	4.46	9.82
Barrhaven Conservancy East 4	Singles	0	3.4	-	-	-	-
	Towns	401	2.7	1,083	3.51	19.30	19.30
Phase 4 Sub-total		401	-	1,083	3.51	8.77	19.30
Jock River Phase 1	Singles	105	3.4	357	1.16	2.89	6.36
	Towns	0	2.7	-	-	-	-
Jock River Phase 1 Sub-total		105	-	357	1.16	2.89	6.36
Jock River Phase 2	Singles	151	3.4	513	1.66	4.16	9.15
	Towns	0	2.7	-	-	-	-
Jock River Phase 2 Sub-total		151	-	513	1.66	4.16	9.15
Jock River Phase 3	Singles	67	3.4	228	0.74	1.85	4.06
	Towns	0	2.7	-	-	-	-
Jock River Phase 3 Sub-total		67	-	228	0.74	1.85	4.06
Barrhaven Conservancy East Ultimate Build-out		1,272	-	3,803	12.33	30.81	67.79

2 Hydraulic Assessment

2.1 Performance Criteria

As per the City’s Water Design Guidelines, normal operating pressures in a distribution system range from 350 to 480 kPa (50 to 70 psi) and not less than 275 kPa (40 psi). The maximum pressure in the distribution system should not exceed 552 kPa (80 psi). Pressure reducing measures are required to service areas where pressures greater than 552 kPa (80 psi) are anticipated.

Under emergency fire conditions, the system must be able to supply appropriate fire flow while maintaining a residual pressure of 138 kPa (20 psi). **Table 2** provides a summary of the scenarios and the corresponding recommended pressures.

Reference: Barrhaven Conservancy East Phasing Update Hydraulic Model

Table 2: Recommended Performance Criteria

Criteria and Scenario	Pressure Threshold	
	kPa	psi
Maximum Pressure under AVDY	700	80
Minimum Residual Pressure under MXDY+FF ¹	140	20
Minimum Pressure under PKHR	275	40

¹ The required fire flow (RFF) for the Barrhaven Conservancy East lands was calculated at 13,000 L/min, or 216.67 L/s in Stantec's June 2022 report. This fire flow was carried over in this analysis. It is recommended that FUS calculations for the Barrhaven Conservancy East lands be reviewed at the detailed design stage to ensure that fire flow requirements are met across the site.

3 Water System Model

The original water system model was developed using the Infowater Pro software. Following the latest concept plans received for the Barrhaven Conservancy East lands, the water system model was updated to capture the new unit densities and water demands, as well as the proposed road alignment of what is now referred to as Les Emmerson Drive.

3.1 Boundary Conditions

The proposed development will ultimately have three (3) connections points to the City's existing water distribution system. However, this hydraulic analysis will only consider servicing for Caivan's Barrhaven Conservancy East Development via two (2) initial connections:

- Connection #1: The existing 305 mm stub extending from Chapman Mills Drive; and
- Connection #2: The T-junction on the existing 203 mm watermain at Danson Gardens Grove and Darjeeling Avenue.

A third connection, through the future 305 mm stub at the intersection of Flagstaff Drive and Borriskane Road, will eventually be implemented to service the development lands. Results from the initial analysis (i.e., with two connections) will dictate whether an assessment with the third connection is required as part of this study. Analyzing the ultimate Barrhaven Conservancy East Development under two connections is a conservative approach, given that the third connection will eventually be implemented.

Lastly, the development area will ultimately be serviced by the pressure Zone SUC once the reconfiguration is complete (planned by mid 2025). As such, the hydraulic analysis and proposed watermain sizing and layout documented in this report only considers the Zone SUC servicing conditions (see **Table 3**).

Reference: Barrhaven Conservancy East Phasing Update Hydraulic Model

Table 3: Boundary Condition after SUC Reconfiguration under AVDY, PKHR, MXDY+FF Scenarios

Demand Scenario	Connection 1 - Chapman Mills Drive		Connection 2 - Danson Gardens Grove & Darjeeling Ave	
	Head (m)	Pressure (psi)	Head (m)	Pressure (psi)
AVDY	146.8	76.4	146.8	78.3
PKHR	142.7	70.5	142.6	72.3
MXDY+FF	136.3	61.4	132.0	57.3
Ground Elevation (m)	93.1		91.8	

The water boundary condition received from the City for the conditions listed above are attached under **Appendix A2**.

3.2 Proposed Watermain Sizing & Layout

The layout and sizing of the watermains within the proposed Barrhaven Conservancy East Development is shown in **Figure 1**. The network is proposed to consist of 152 mm, 203 mm, and 305 mm, with the 305 mm watermains acting as the hydraulic backbone throughout the development lands. The 305 mm backbone watermains connect at two (2) locations to the watermains within the Conservancy East Development lands. Note that **Figure 2** is a schematic representation of the hydraulic model layout.

Furthermore, it is important to note that to avoid the creation of a vulnerable service area within the Barrhaven Conservancy East Development Phase 3, considering that 204 units are proposed for this phase, a secondary connection to Phase 3 is required before the completion of Barrhaven Conservancy East Development Phase 4. As such, a loop to Barrhaven Conservancy East Development Phase 2, as depicted on **Figure 2**, through Phase 4 lands is needed to adequately service Phase 3 under interim conditions.

3.3 Hydraulic Model Results

The updated water model was used to assess the hydraulic conditions under the full buildout scenario for the Barrhaven Conservancy East Development. Furthermore, note that the initial assessment considers only two (2) connections to the City’s existing network, as noted in **Section 3.1**.

3.3.1 AVERAGE DAY & PEAK HOUR DEMANDS

Maximum modelled pressures under AVDY demands are 77 psi, which are lower than the City’s maximum pressure objective of 80 psi. The maximum pressure target is satisfied accordingly. Under PKHR demands, minimum modelled pressures are 69 psi. These pressures fall within the desired pressure range of 50 to 80 psi and are thus considered acceptable. Detailed modelling results are provided in **Appendix A4**. Refer to model system map shown in **Appendix A3** for model node locations. Based on this results, the proposed two connections would be able to service the development area within acceptable pressure ranges as per City of Ottawa guidelines.

Figure 2- Pipeline outline of The Barrhaven Conservancy East Development Project

Barrhaven Conservancy Development Corporations

Project Location
Barrhaven Conservancy, Ottawa, ON

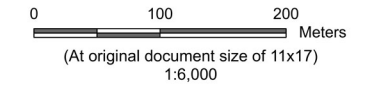

Legend

★ Connections to the network

● Junctions

Pipe Diameter (mm)

— 152

— 203

— 305

Phasing

■ Barrhaven Conservancy East Phase 2

■ Barrhaven Conservancy East Phase 3

■ Barrhaven Conservancy East Phase 4

■ Jock River Phase 1

■ Jock River Phase 2

■ Jock River Phase 3

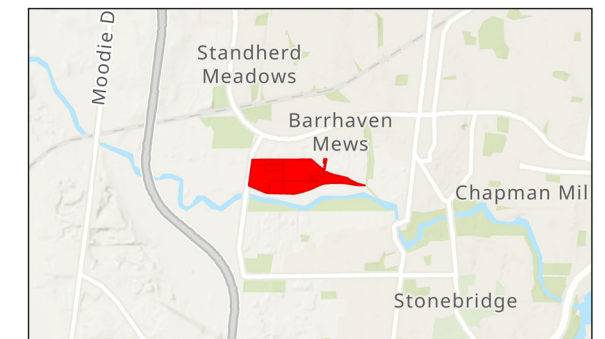
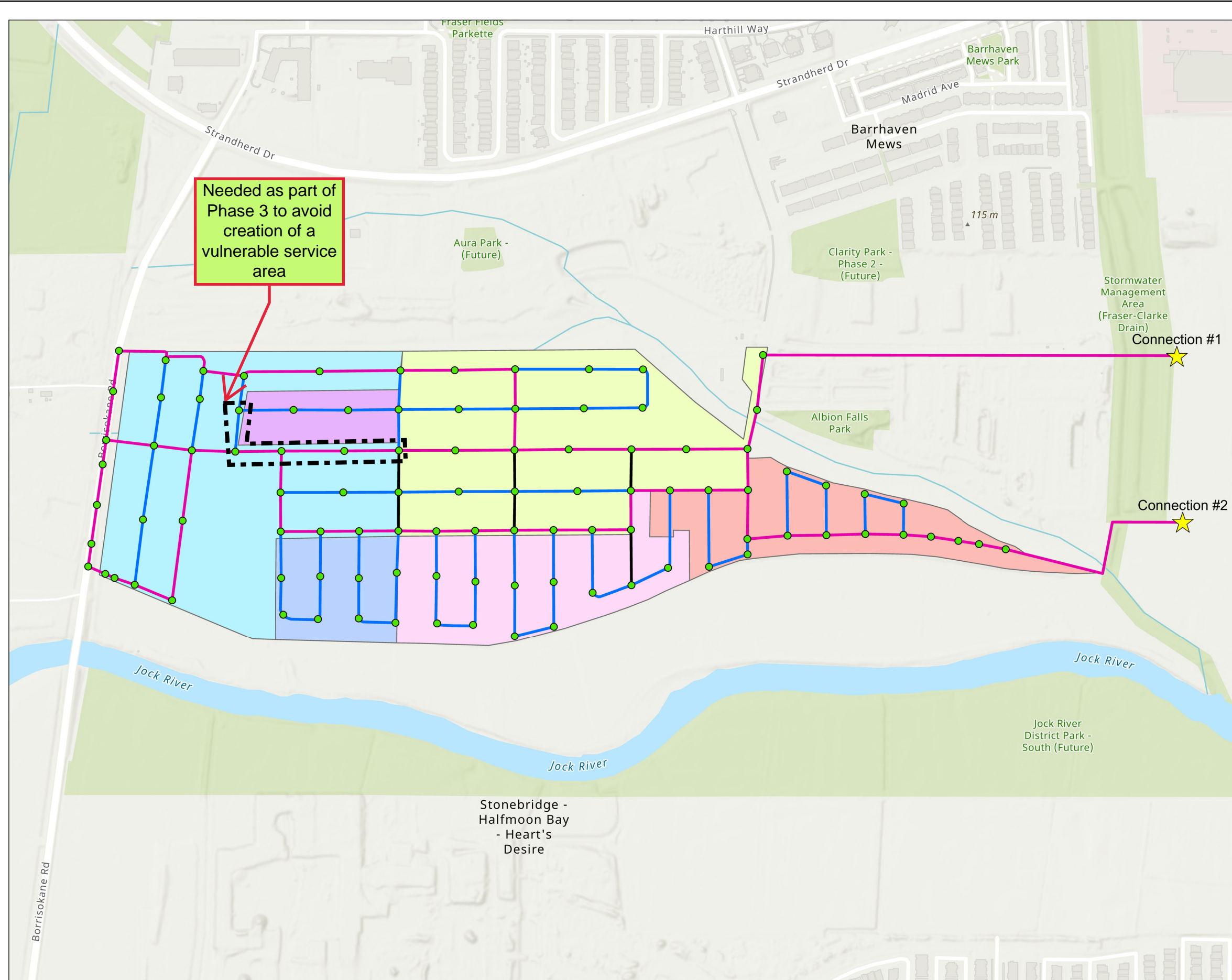

Notes
1. Coordinate System: NAD 1983 CSRS MTM 9



Reference: Barrhaven Conservancy East Phasing Update Hydraulic Model

3.3.2 MAXIMUM DAY DEMAND AND FIRE FLOW

Under MXDY+FF conditions, a minimum residual pressure of 20 psi must be maintained under the target fire flow of 216.67 L/s (13,000 L/min).

Modelled results under MXDY+FF conditions show that fire flows greater than 13,000 L/min are achievable, with a residual pressure of 138 kPa (20 psi), in most locations within the Barrhaven Conservancy East Development lands. However, there are a few locations outlined in Table A3-3 of **Appendix A4** (junctions J85, J86, and J87), where the residual pressures during fire flow conditions are below 138 kPa (20 psi). The worst-case scenario is at node J86, where a fire flow of 205 L/s (12,283 L/min) is available at a residual pressure of 138 kPa.

It is worth noting that if the alternative procedure as outlined in Appendix I (Guidelines on Coordination of Hydrant Placement with Required Fire Flow) of the City's Technical Bulletin ISDTB-2018-02 is employed, namely assuming a maximum flow capacity of 5,700 L/min per class AA hydrant within 75 m of the nodes, and a maximum flow capacity of 3,800 L/min for Class AA hydrants between 75 and 150 m, a fire flow of 216.67 L/s (13,000 L/min) is achieved across the whole network.

Given that this analysis considered a conservative scenario of providing only two (2) connections to the existing City's network, results from the hydraulic analysis suggest that appropriate fire protection will be provided within Barrhaven Conservancy East Development lands with only two (2) connections. As such, it is anticipated that the third connection would improve the hydraulic conditions within the development lands.

Nonetheless, fire flow requirements across the Barrhaven Conservancy East Development lands are to be confirmed at the detailed design stage and fire control measures are to be included as required. These fire control measures may include adding ordinary construction units, the addition of firewalls and/or using the alternative hydrant placing procedure outlined in Appendix I of ISDTB-2018-02 to avoid oversizing local pipes.

4 Conclusion

A water distribution system hydraulic analysis was completed in support of DSEL's functional design for Phases 3 and 4 of the Barrhaven Conservancy East Development lands. The purpose of this analysis was to confirm associated watermain sizing to support recent updates to the proposed concept plans for the development lands. Based on the hydraulic analysis, the following conclusions and recommendations are made:

- The previously fire flow objective of 216.67 L/s (13,000 L/min) as established in the analysis of the Barrhaven Conservancy East Development lands (Stantec Consulting Ltd., 2022) was used for this analysis. It is recommended that FUS calculations be completed at the detailed design stage to ensure that fire flow requirements are met across the site.
- Previous studies related to the Barrhaven Conservancy East Development lands analyzed the serviceability of the development via two (2) and three (3) watermain connections scenarios. This study only considered the scenario with two (2) connections, given that Barrhaven Conservancy East Development Phases 3 and 4 would advance prior to the construction of the third connection. Furthermore, the analysis in this report considers the future zone SUC servicing conditions only.

Reference: Barrhaven Conservancy East Phasing Update Hydraulic Model

- To avoid the creation of a vulnerable service area within the Barrhaven Conservancy East Development Phase 3, a secondary connection to these lands is needed prior to the development of the Barrhaven Conservancy East Development Phase 4. As such, a secondary loop to the Barrhaven Conservancy East Development Phase 2, through the future Phase 4 lands is needed to adequately service Barrhaven Conservancy East Development Phase 3 under interim conditions.
- Under AVDY demand conditions, model results suggest that maximum pressures are below the allowable maximum pressure of 80 psi in accordance with the City of Ottawa Design Guidelines. Under PKHR demand conditions, the minimum pressures are in accordance with the City's system pressure requirements.
- Under MXDY+FF demand conditions, the assumed required fire flow of 13,000 L/min can be achieved across most the proposed network under full build out conditions for the Barrhaven Conservancy East Development lands, with the exception of a few locations, where the worst-case scenario results in a maximum fire flow of 205 L/s (12,283 L/min) available at a residual pressure of 138 kPa (20 psi). Fire flow requirements across the Barrhaven Conservancy East Development lands are to be confirmed at the detailed design stage and fire control measures are to be included as required. These fire control measures may include adding ordinary construction units, the addition of firewalls and/or using the alternative hydrant placing procedure outlined in Appendix I of ISDTB-2018-02 to avoid oversizing local pipes.
- Results from the hydraulic analysis suggest that appropriate hydraulic conditions would be provided for the Barrhaven Conservancy East Development lands with only two (2) connections to the existing City's network are considered. However, the third connection (across the Jock River through the future 305 mm stub at the intersection of Flagstaff Drive and Borrisokane Road) would improve the fire protection capacity within the Barrhaven Conservancy East Development lands, as well as provide further redundancy to the development lands.

STANTEC CONSULTING LTD.

Hamidreza Mohabbat M.A.Sc.
Water Resources Designer
Phone: (416) 598-7138
Hamidreza.mohabbat@stantec.com

Alexandre Mineault-Guitard ing., P.Eng
Water Resources Engineer
Phone: (613) 725-5532
alexandre.mineault-guitard@stantec.com

Attachment:

Appendix A1: Development Concept Plan
Appendix A2: Boundary Conditions
Appendix A3: Model System Map
Appendix A4: Modelling Results

June 24, 2024
Daniel Rokin

Reference: Barrhaven Conservancy East Phasing Update Hydraulic Model

Appendix A1: Development Concept Plan

DRAFT

CAIVAN

LEGEND:

- RLTH (18.9m DEPTH)
 - 19.6' STANDARD TOWNHOUSE
 - 35' DETACHED HOME
 - 41' DETACHED HOME (REGULAR)
 - 41' DETACHED HOME (OVERSIZED)
 - 42' DETACHED HOME
 - 50' DETACHED HOME
 - STACKED CONDO BLOCK
 - PARKS
 - WALKWAY/SERVICING BLOCK
 - PHASE BOUNDARY
 - BCDCE DRAFT PLAN DEVISING LINE
-
- 24m ROW
 - 18m ROW
 - 16.5m ROW
 - 14/14.75m ROW
 - 8.5m ROW

BCDCE LOT COUNT

UNIT TYPE	# UNITS
STACKED	204
18.9m RLTH	87
19.6' TH	454
35' SINGLE	189
41' REGULAR	52
41' OVERSIZED	33
42' SINGLE	118
50' SINGLE	135
Total	1272

15	Unit count recount, tables updated to reflect	24-03-07
14	revisions made on sk-8.2 now sk-8.3	24-02-21
13	SK8.2 NEW UNIT COUNT REOPTIMIZED BANKS	24/02/21
12	Revised Les Emmerson, removed TH block for singles	24/02/13
11	Updated STND TH to new 19.6' TH	24/01/18
10	Updated Plan and Phasing and unit counts	24/01/11
09	Revised BCDCE from Stacks to 19' THs	23/12/15
REV#	DESCRIPTION	DATE

DATE:	DRAWN BY:
2024-03-07	LV

PROJECT NO.:	OTL400.2
--------------	----------

PROJECT NAME:	CONSERVANCY EAST
---------------	------------------

DRAWING #:	SK-08.3
------------	---------

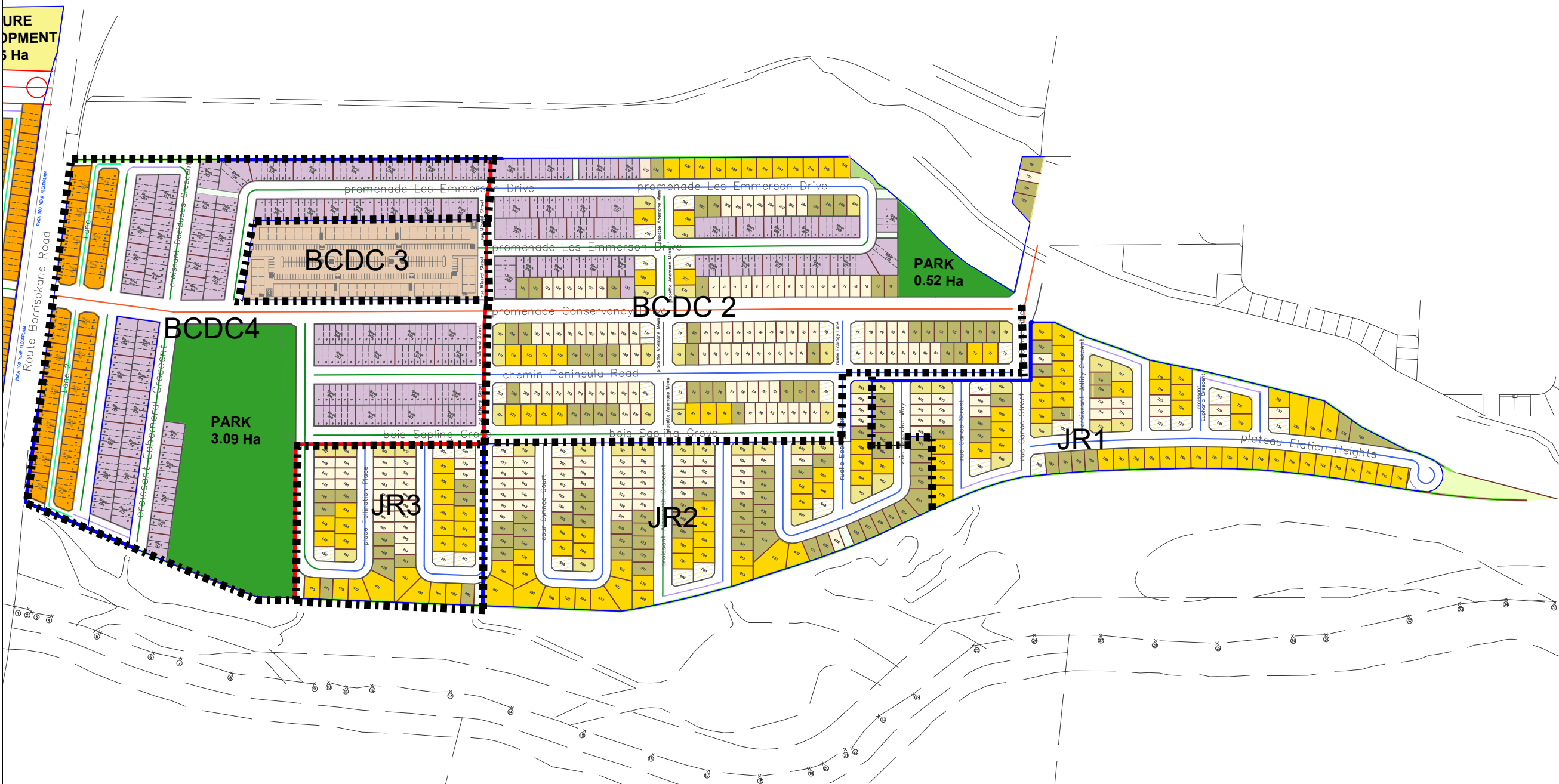

East of Mineral (1/300)	2.2233	ha
West of Mineral (1/600)	1.0083	ha
Total Required	3.2317	ha
Total Parkland in Provided BCDCE E	3.6100	ha
Total Overdedication in BCDCE East	0.3783	ha

Unit Type	BCDC 2	BCDC 3	BCDC 4	JR. 1	JR. 2	JR. 3	Type Total
Stacked		204					204
RLT			87				87
19.6' TH	140		314				454
35' Single	100			18	47	24	189
41' Regular	16			10	15	5	46
41' Oversize	13			9	6	5	33
42' Single	46			19	48	11	124
50' Single	29			49	35	22	135
Sub-Total	344	204	401	105	151	67	1272
Total							1272

Appendix A2: Boundary Conditions

DRAFT

Boundary Conditions Barrhaven Conservancy – East

Provided Information

Scenario	Demand	
	L/min	L/s
Average Daily Demand	740	12.33
Maximum Daily Demand	1,849	30.81
Peak Hour	4,067	67.79
Fire Flow Demand #1	13,000	216.67

Location

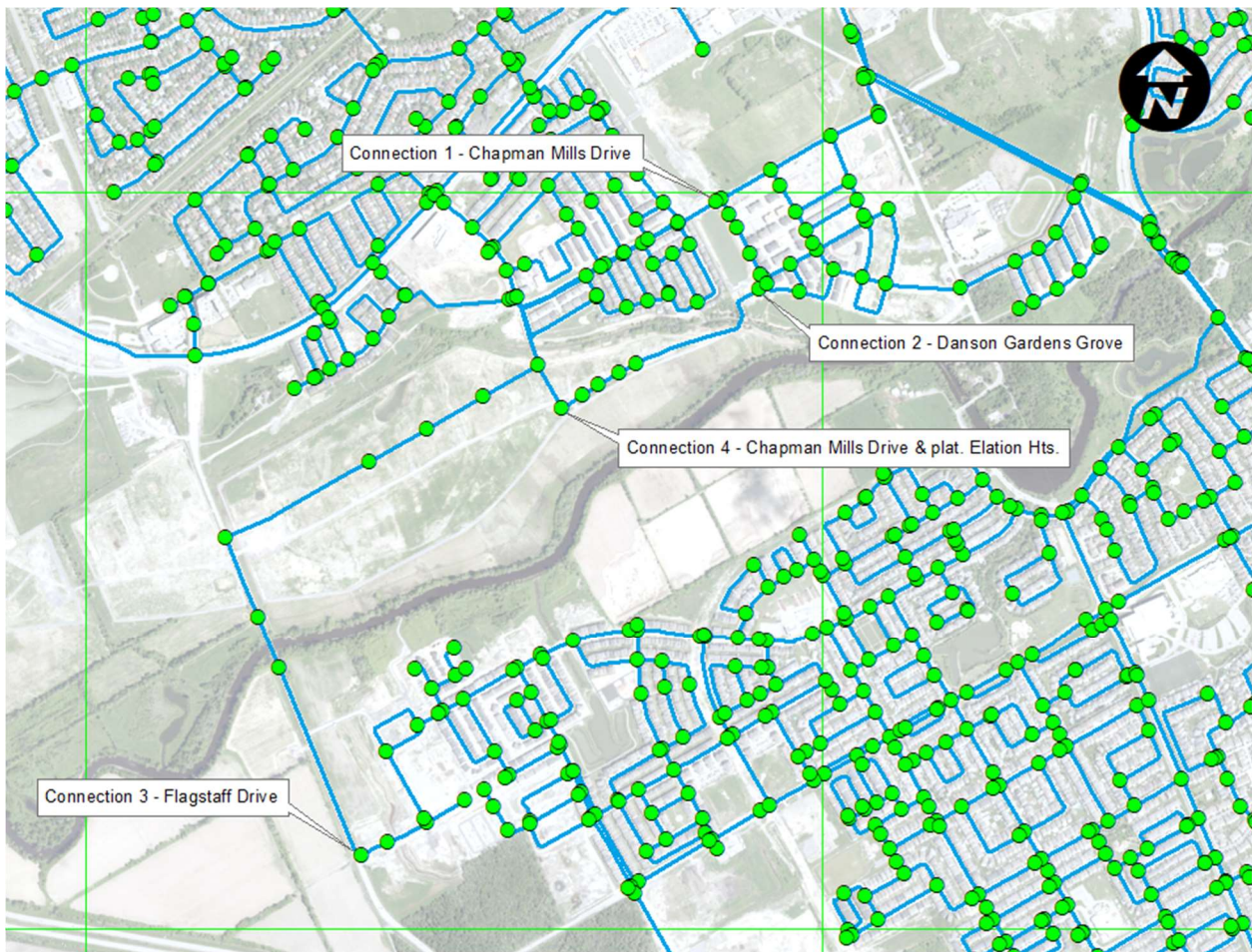

Results

Scenario 1 : Connection 1 & 2 at Chapman Mills Drive & Danson Gardens Grove

Future Condition (Post- SUC Pressure Zone Reconfiguration)

Connection 1 - Chapman Mills Drive

Demand Scenario	Head (m)	Pressure ¹ (psi)
Maximum HGL	146.8	76.4
Peak Hour	142.7	70.5
Max Day plus Fire Flow #1	136.3	61.4

¹ Ground Elevation = 93.1 m

Connection 2 - Danson Gardens Grove & DarJeeling Ave

Demand Scenario	Head (m)	Pressure ¹ (psi)
Maximum HGL	146.8	78.3
Peak Hour	142.6	72.3
Basic Day Demands plus Fire Flow*	124.4	46.4
Max Day plus Fire Flow #1	132.0	57.3

¹ Ground Elevation = 91.8 m

Notes

1. As per the Ontario Building Code in areas that may be occupied, the static pressure at any fixture shall not exceed 552 kPa (80 psi.) Pressure control measures to be considered are as follows, in order of preference:
 - a. If possible, systems to be designed to residual pressures of 345 to 552 kPa (50 to 80 psi) in all occupied areas outside of the public right-of-way without special pressure control equipment.
 - b. Pressure reducing valves to be installed immediately downstream of the isolation valve in the home/ building, located downstream of the meter so it is owner maintained.

Disclaimer

The boundary condition information is based on current operation of the city water distribution system. The computer model simulation is based on the best information available at the time. The operation of the water distribution system can change on a regular basis, resulting in a variation in boundary conditions. The physical properties of watermains deteriorate over time, as such must be assumed in the absence of actual field test data. The variation in physical watermain properties can therefore alter the results of the computer model simulation. Fire Flow analysis is a reflection of available flow in the watermain; there may be additional restrictions that occur between the watermain and the hydrant that the model cannot take into account.

Appendix A3: Model System Map

DRAFT

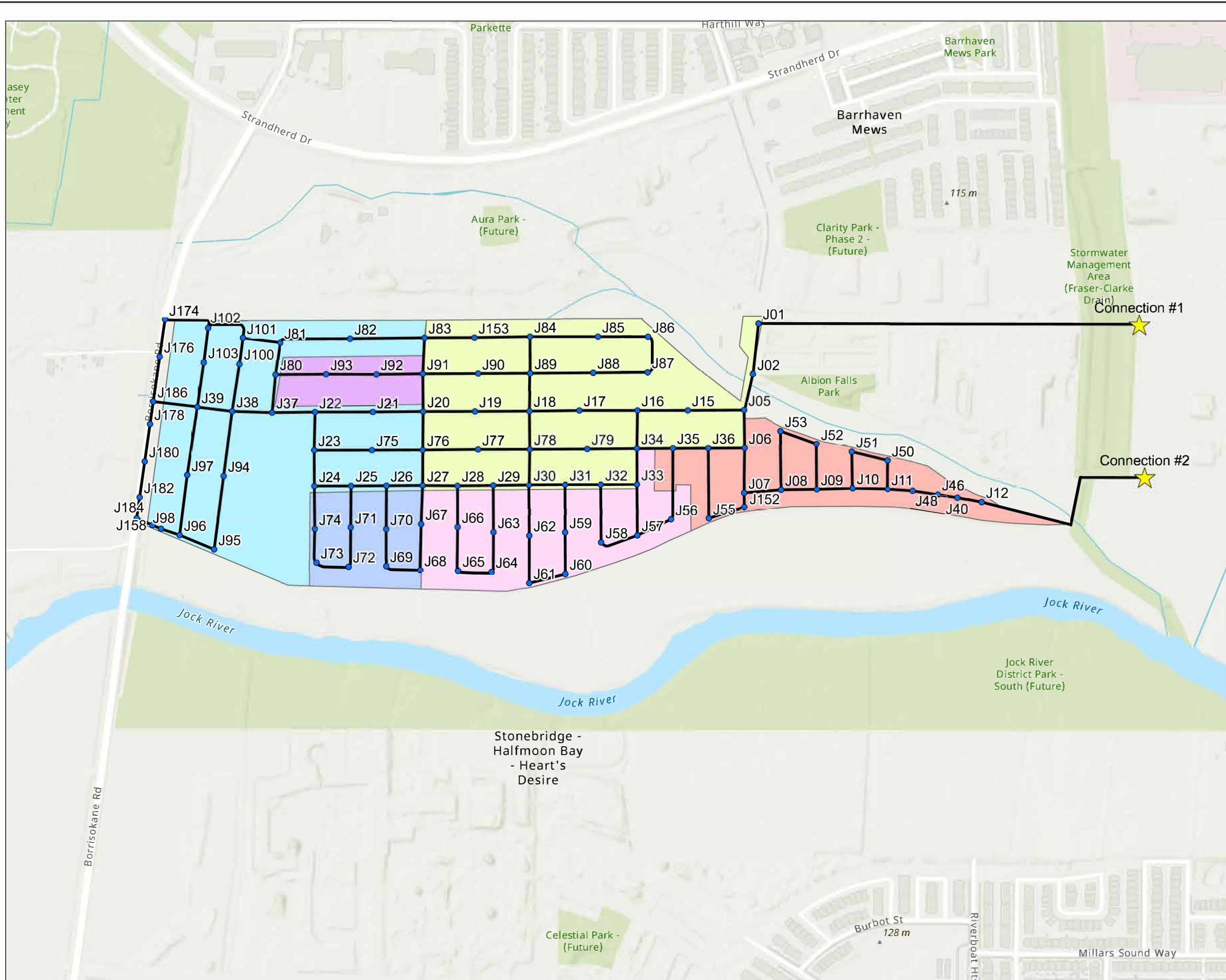

Title
Appendix A3- Model System Map

Client/Project 163401964
Barrhaven Conservancy Development Corporations

Project Location
Barrhaven Conservancy, Ottawa, ON

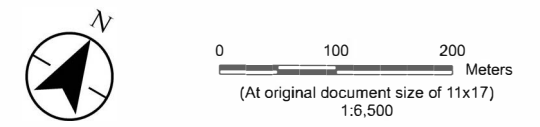

- Legend**
- ★ Connections to the network
 - Junctions
 - Pipes
- Phasing**
- Barrhaven Conservancy East Phase 2
 - Barrhaven Conservancy East Phase 3
 - Barrhaven Conservancy East Phase 4
 - Jock River Phase 1
 - Jock River Phase 2
 - Jock River Phase 3

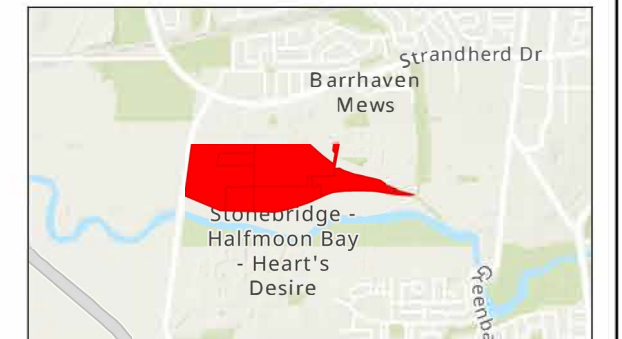

Notes
1. Coordinate System: NAD 1983 CSRS MTM 9



Appendix A4: Modelling Results

DRAFT

163401964 - Barrhaven Conservancy East: Water Distribution System Analysis

Table A3-1: Model Results - AVDY

Junction ID	Demand (L/s)	Head (m)	Pressure (psi)
<i>Maximum</i>	0.89	146.78	77.3
<i>Minimum</i>	0.00	146.75	75.7
J01	0.00	146.77	75.7
J02	0.00	146.77	76.3
J05	0.11	146.76	76.8
J06	0.11	146.76	77.0
J07	0.00	146.77	77.1
J08	0.00	146.77	77.0
J09	0.00	146.77	76.5
J10	0.00	146.77	76.8
J100	0.14	146.75	76.2
J101	0.14	146.75	76.3
J102	0.14	146.75	76.2
J103	0.14	146.75	76.1
J11	0.00	146.78	76.6
J12	0.00	146.78	76.5
J15	0.11	146.76	76.7
J152	0.19	146.77	77.2
J153	0.11	146.75	76.2
J158	0.14	146.75	77.1
J16	0.11	146.76	76.8
J17	0.11	146.76	76.7
J174	0.14	146.75	76.4
J176	0.14	146.75	76.5
J178	0.14	146.75	76.7
J18	0.11	146.75	76.4
J180	0.14	146.75	77.0
J182	0.14	146.75	77.1
J184	0.14	146.75	77.1
J186	0.14	146.75	76.6
J19	0.11	146.75	76.2
J20	0.11	146.75	76.7
J21	0.00	146.75	76.5
J22	0.00	146.75	76.6
J23	0.14	146.75	76.7
J24	0.14	146.75	76.9
J25	0.14	146.75	76.7
J26	0.14	146.75	76.8
J27	0.11	146.75	77.0
J28	0.11	146.75	76.9
J29	0.11	146.75	76.9
J30	0.11	146.76	76.8
J31	0.11	146.76	77.0
J32	0.11	146.76	76.9
J33	0.11	146.76	77.1
J34	0.11	146.76	77.0
J35	0.11	146.76	76.9
J36	0.11	146.76	77.1
J37	0.00	146.75	76.5
J38	0.14	146.75	76.6
J39	0.14	146.75	76.6
J40	0.00	146.78	76.5
J46	0.00	146.78	76.6
J48	0.00	146.78	76.6
J50	0.19	146.77	76.5
J51	0.19	146.77	76.7
J52	0.19	146.77	76.7
J53	0.19	146.77	76.8
J55	0.19	146.76	77.3
J56	0.15	146.76	77.1
J57	0.15	146.76	77.3
J58	0.15	146.76	77.1
J59	0.15	146.76	77.0
J60	0.15	146.76	77.3
J61	0.15	146.76	77.1
J62	0.15	146.76	77.0
J63	0.15	146.75	77.1
J64	0.15	146.75	77.2
J65	0.15	146.75	77.2
J66	0.15	146.75	77.1
J67	0.09	146.75	77.1
J68	0.09	146.75	77.3
J69	0.09	146.75	77.1
J70	0.09	146.75	77.0
J71	0.09	146.75	76.9
J72	0.09	146.75	77.0
J73	0.09	146.75	77.1
J74	0.09	146.75	77.0
J75	0.14	146.75	76.7
J76	0.11	146.75	76.8
J77	0.11	146.75	76.6
J78	0.11	146.76	76.7
J79	0.11	146.76	76.8
J80	0.00	146.75	76.4
J81	0.14	146.75	76.2
J82	0.14	146.75	76.2
J83	0.11	146.75	76.4
J84	0.11	146.75	76.3
J85	0.11	146.75	76.4
J86	0.11	146.75	76.6
J87	0.11	146.75	76.6
J88	0.11	146.75	76.4
J89	0.11	146.75	76.4
J90	0.11	146.75	76.3
J91	0.11	146.75	76.6
J92	0.89	146.75	76.4
J93	0.89	146.75	76.3
J94	0.14	146.75	76.9
J95	0.14	146.75	77.1
J96	0.14	146.75	77.0
J97	0.14	146.75	76.8
J98	0.14	146.75	76.9

163401964 - Barrhaven Conservancy East: Water Distribution System Analysis

Table A3-2: Model Results - PKHR

Junction ID	Demand (L/s)	Head (m)	Pressure (psi)
Maximum	4.91	142.22	70.2
Minimum	0.00	141.52	68.6
J01	0.00	142.04	69.0
J02	0.00	141.89	69.4
J05	0.60	141.82	69.8
J06	0.60	141.81	69.9
J07	0.00	141.85	70.1
J08	0.00	141.90	70.1
J09	0.00	141.94	69.6
J10	0.00	142.00	70.0
J100	0.74	141.53	68.8
J101	0.74	141.53	68.9
J102	0.74	141.53	68.8
J103	0.74	141.53	68.6
J11	0.00	142.05	69.9
J12	0.00	142.22	70.0
J15	0.60	141.75	69.6
J152	1.06	141.84	70.2
J153	0.60	141.55	68.8
J158	0.74	141.53	69.7
J16	0.60	141.69	69.6
J17	0.60	141.63	69.4
J174	0.74	141.53	69.0
J176	0.74	141.53	69.1
J178	0.74	141.53	69.3
J18	0.60	141.58	69.1
J180	0.74	141.53	69.5
J182	0.74	141.53	69.6
J184	0.74	141.53	69.7
J186	0.74	141.53	69.2
J19	0.60	141.57	68.9
J20	0.60	141.56	69.3
J21	0.00	141.55	69.1
J22	0.00	141.55	69.2
J23	0.74	141.55	69.3
J24	0.74	141.55	69.5
J25	0.74	141.55	69.3
J26	0.74	141.56	69.5
J27	0.60	141.56	69.6
J28	0.60	141.57	69.5
J29	0.60	141.58	69.5
J30	0.60	141.59	69.5
J31	0.60	141.61	69.6
J32	0.60	141.64	69.6
J33	0.60	141.66	69.8
J34	0.60	141.68	69.7
J35	0.60	141.72	69.8
J36	0.60	141.77	70.0
J37	0.00	141.54	69.1
J38	0.74	141.53	69.2
J39	0.74	141.53	69.2
J40	0.00	142.18	70.0
J46	0.00	142.14	70.0
J48	0.00	142.09	70.0
J50	1.06	142.03	69.8
J51	1.06	142.01	69.9
J52	1.06	141.92	69.8
J53	1.06	141.91	69.9
J55	1.06	141.81	70.2
J56	0.83	141.68	69.9
J57	0.83	141.66	70.0
J58	0.83	141.65	69.9
J59	0.83	141.60	69.7
J60	0.83	141.60	69.9
J61	0.83	141.60	69.8
J62	0.83	141.59	69.7
J63	0.83	141.57	69.7
J64	0.83	141.57	69.8
J65	0.83	141.57	69.9
J66	0.83	141.57	69.7
J67	0.51	141.56	69.7
J68	0.51	141.56	69.9
J69	0.51	141.56	69.7
J70	0.51	141.56	69.6
J71	0.51	141.55	69.5
J72	0.51	141.55	69.6
J73	0.51	141.55	69.7
J74	0.51	141.55	69.6
J75	0.74	141.55	69.3
J76	0.60	141.56	69.5
J77	0.60	141.58	69.2
J78	0.60	141.59	69.4
J79	0.60	141.64	69.5
J80	0.00	141.53	68.9
J81	0.74	141.53	68.8
J82	0.74	141.54	68.8
J83	0.60	141.55	69.0
J84	0.60	141.56	68.9
J85	0.60	141.56	69.0
J86	0.60	141.56	69.2
J87	0.60	141.56	69.2
J88	0.60	141.56	69.1
J89	0.60	141.56	69.1
J90	0.60	141.55	68.9
J91	0.60	141.55	69.2
J92	4.91	141.52	68.9
J93	4.91	141.52	68.8
J94	0.74	141.53	69.5
J95	0.74	141.53	69.7
J96	0.74	141.53	69.6
J97	0.74	141.53	69.3
J98	0.74	141.53	69.5

163401964 - Barrhaven Conservancy East: Water Distribution System Analysis

Table A3-3: Model Results - MXDY+FF

Junction ID	Base Demand (L/s)	Required Fire Flow (L/s)	Residual Pressure (psi)	Available Fire Flow @ Residual 20 psi (L/s)
Maximum	2.23	216.67	48.01	484.40
Minimum	0.00	216.67	15.91	204.72
J01	0.00	216.67	45.37	413.59
J02	0.00	216.67	44.86	402.79
J05	0.27	216.67	44.99	402.67
J06	0.27	216.67	45.06	403.15
J07	0.00	216.67	45.39	407.40
J08	0.00	216.67	45.55	412.26
J09	0.00	216.67	45.31	414.61
J10	0.00	216.67	46.01	425.71
J100	0.34	216.67	29.99	259.48
J101	0.34	216.67	34.93	291.35
J102	0.34	216.67	34.04	285.06
J103	0.34	216.67	28.42	251.38
J11	0.00	216.67	46.27	433.48
J12	0.00	216.67	48.01	484.40
J15	0.27	216.67	42.44	364.73
J152	0.48	216.67	40.84	339.84
J153	0.27	216.67	35.65	297.30
J158	0.34	216.67	32.97	275.54
J16	0.27	216.67	41.44	351.07
J17	0.27	216.67	39.76	333.16
J174	0.34	216.67	33.40	280.04
J176	0.34	216.67	33.50	280.43
J178	0.34	216.67	33.69	281.21
J18	0.27	216.67	38.82	325.02
J180	0.34	216.67	33.15	277.08
J182	0.34	216.67	32.92	275.36
J184	0.34	216.67	32.93	275.29
J186	0.34	216.67	34.31	285.85
J19	0.27	216.67	37.35	311.60
J20	0.27	216.67	37.93	315.05
J21	0.00	216.67	37.15	308.31
J22	0.00	216.67	37.67	313.03
J23	0.34	216.67	37.60	312.06
J24	0.34	216.67	37.34	309.02
J25	0.34	216.67	37.15	307.82
J26	0.34	216.67	37.44	309.93
J27	0.27	216.67	37.95	313.90
J28	0.27	216.67	38.08	315.33
J29	0.27	216.67	38.43	318.54
J30	0.27	216.67	39.07	325.05
J31	0.27	216.67	39.52	328.92
J32	0.27	216.67	40.11	335.61
J33	0.27	216.67	40.92	343.40
J34	0.27	216.67	41.78	354.65
J35	0.27	216.67	42.50	364.35
J36	0.27	216.67	43.92	383.55
J37	0.00	216.67	36.51	303.14
J38	0.34	216.67	35.54	295.10
J39	0.34	216.67	34.84	289.76
J40	0.00	216.67	47.47	467.08
J46	0.00	216.67	47.10	455.87
J48	0.00	216.67	46.67	443.59
J50	0.48	216.67	39.34	327.36
J51	0.48	216.67	38.71	320.23
J52	0.48	216.67	35.40	291.81
J53	0.48	216.67	34.58	285.60
J55	0.48	216.67	36.09	295.13
J56	0.38	216.67	30.65	261.04
J57	0.38	216.67	32.48	271.25
J58	0.38	216.67	30.99	262.95
J59	0.38	216.67	26.60	241.69
J60	0.38	216.67	22.61	225.85
J61	0.38	216.67	22.12	224.13
J62	0.38	216.67	26.10	239.51
J63	0.38	216.67	26.25	240.17
J64	0.38	216.67	22.67	226.07
J65	0.38	216.67	22.75	226.39
J66	0.38	216.67	27.02	243.59
J67	0.23	216.67	27.22	244.30
J68	0.23	216.67	22.68	225.97
J69	0.23	216.67	22.71	226.10
J70	0.23	216.67	26.20	239.95
J71	0.23	216.67	26.33	240.56
J72	0.23	216.67	22.68	226.05
J73	0.23	216.67	22.97	227.04
J74	0.23	216.67	26.24	240.08
J75	0.34	216.67	29.07	253.73
J76	0.27	216.67	33.73	280.71
J77	0.27	216.67	29.00	253.36
J78	0.27	216.67	35.02	289.85
J79	0.27	216.67	32.10	269.88
J80	0.00	216.67	33.25	278.75
J81	0.34	216.67	35.23	294.10
J82	0.34	216.67	34.96	291.80
J83	0.27	216.67	36.10	300.04
J84	0.27	216.67	36.51	303.92
J85	0.27	216.67	16.80	216.36
J86	0.27	216.67	15.91	204.72
J87	0.27	216.67	15.94	204.76
J88	0.27	216.67	20.72	219.33
J89	0.27	216.67	37.50	312.25
J90	0.27	216.67	28.96	253.65
J91	0.27	216.67	35.61	295.65
J92	2.23	216.67	25.95	241.44
J93	2.23	216.67	25.01	237.50
J94	0.34	216.67	33.50	279.48
J95	0.34	216.67	33.04	275.97
J96	0.34	216.67	33.08	276.52
J97	0.34	216.67	24.55	233.42
J98	0.34	216.67	32.83	275.05

Sufficient hydrant coverage to meet the RFF



David Schaeffer Engineering Ltd.

120 Iber Road, Suite 103

Stittsville, ON K2S 1E9

613-836-0856

dsel.ca

APPENDIX C

SANITARY SEWER CALCULATION SHEET



Manning's n=0.013

LOCATION		RESIDENTIAL AREA AND POPULATION							COMM		INSTIT		PARK		C+H	INFILTRATION			PIPE																
STREET	FROM M.H.	TO M.H.	AREA (ha)	UNITS	UNITS Singles	UNITS Stacked TH	POP.	CUMULATIVE		PEAK FACT.	PEAK FLOW (l/s)	AREA (ha)	ACCU. AREA (ha)	AREA (ha)	ACCU. AREA (ha)	AREA (ha)	ACCU. AREA (ha)	PEAK FLOW (l/s)	TOTAL AREA (ha)	ACCU. AREA (ha)	INFILT. FLOW (l/s)	TOTAL FLOW (l/s)	DIST (m)	DIA (mm)	SLOPE (%)	CAP. (FULL) (l/s)	RATIO Q act/Q cap	VEL.							
								AREA (ha)	POP.																			(FULL) (m/s)	(ACT.) (m/s)						
SAN BLOCK																																			
	128A	129A	0.04	8			19	0.04				0.00		0.00		0.00	0.00	0.04	0.04	0.01	0.01	17.5	200	0.65	26.44	0.00	0.84	0.10							
To LANE 1, Pipe 129A - 130A								0.04	0			0.00		0.00		0.00			0.04																
LANE 2																																			
Contribution From LANE 1, Pipe 126A - 130A								0.24	0			0.00		0.00		0.00		0.24	0.24																
Contribution From LANE 1, Pipe 129A - 130A								0.20	0			0.00		0.00		0.00		0.20	0.44																
	130A	131A	0.16	0			0	0.60	0			0.00		0.00		0.00	0.00	0.16	0.60	0.17	0.17	43.5	200	0.35	19.40	0.01	0.62	0.19							
	131A	23A						0.60	0			0.00		0.00		0.00	0.00	0.00	0.60	0.17	0.17	14.5	200	0.35	19.40	0.01	0.62	0.19							
LANE 1																																			
	126A	130A	0.24	20			46	0.24				0.00		0.00		0.00	0.00	0.24	0.24	0.07	0.07	60.5	200	1.00	32.80	0.00	1.04	0.19							
To LANE 2, Pipe 130A - 131A								0.24	0			0.00		0.00		0.00		0.24	0.24																
Contribution From SAN BLOCK, Pipe 128A - 129A								0.04	0			0.00		0.00		0.00		0.04	0.04																
	129A	130A	0.16	14			33	0.20	0			0.00		0.00		0.00	0.00	0.16	0.20	0.06	0.06	26.5	200	0.35	19.40	0.00	0.62	0.13							
To LANE 2, Pipe 130A - 131A								0.20	0			0.00		0.00		0.00			0.20																
	132A	123A	0.55	30			69	0.55				0.00		0.00		0.00	0.55	0.55	0.16	0.16	79.0	200	0.65	26.44	0.01	0.84	0.23								
	123A	124A	0.05	6			14	0.60	0			0.00		0.00		0.00	0.05	0.60	0.17	0.17	13.0	200	0.35	19.40	0.01	0.62	0.19								
	124A	46A						0.60	0			0.00		0.00		0.00	0.00	0.60	0.17	0.17	11.0	200	0.35	19.40	0.01	0.62	0.19								

DESIGN PARAMETERS Park Flow = 9300 L/ha/da Average Daily Flow = 280 l/p/day Comm/Inst Flow = 28000 L/ha/da Industrial Flow = 35000 L/ha/da Max Res. Peak Factor = 4.00 Commercial/Inst./Park Peak Factor = 1.50 Institutional = 0.32 l/s/ha Industrial Peak Factor = as per MOE Graph Extraneous Flow = 0.286 L/s/ha Minimum Velocity = 0.600 m/s Manning's n = (Conc) 0.013 (Pvc) 0.013 Townhouse coeff= 2.7 Single house coeff= 3.4										Designed: M.S. Checked: X.W. Dwg. Reference: Sanitary Drainage Plan, Dwgs. No. 11					PROJECT: 1398 - BCDC EAST STACKED CONDO SITE PLAN LOCATION: City of Ottawa File Ref: _____ Date: 30 Aug 2024 Sheet No. 1 of 1									
---	--	--	--	--	--	--	--	--	--	---	--	--	--	--	--	--	--	--	--	--	--	--	--	--



David Schaeffer Engineering Ltd.

120 Iber Road, Suite 103

Stittsville, ON K2S 1E9

613-836-0856

dsel.ca

APPENDIX D

PROJECT INFORMATION	
ENGINEERED PRODUCT MANAGER:	HAIDER NASRULLAH 647-850-9417 HAIDER.NASRULLAH@ADSPIPE.COM
ADS SALES REP:	BRAD DUNLOP 613-893-7336 BRAD.DUNLOP@ADSPIPE.COM
PROJECT NO:	S430138
ONTARIO SITE COORDINATOR:	RYAN RUBENSTEIN 519-710-3687 RYAN.RUBENSTEIN@ADSPIPE.COM



1398 BCDC
OTTAWA, ON.

DC-780 STORMTECH CHAMBER SPECIFICATIONS

- CHAMBERS SHALL BE STORMTECH DC-780.
- CHAMBERS SHALL BE ARCH-SHAPED AND SHALL BE MANUFACTURED FROM VIRGIN, IMPACT-MODIFIED POLYPROPYLENE COPOLYMERS.
- CHAMBERS SHALL BE CERTIFIED TO CSA B184, "POLYMERIC SUB-SURFACE STORMWATER MANAGEMENT STRUCTURES", AND MEET THE REQUIREMENTS OF ASTM F2418, "STANDARD SPECIFICATION FOR POLYPROPYLENE (PP) CORRUGATED WALL STORMWATER COLLECTION CHAMBERS".
- CHAMBER ROWS SHALL PROVIDE CONTINUOUS, UNOBSTRUCTED INTERNAL SPACE WITH NO INTERNAL SUPPORTS THAT WOULD IMPEDE FLOW OR LIMIT ACCESS FOR INSPECTION.
- THE STRUCTURAL DESIGN OF THE CHAMBERS, THE STRUCTURAL BACKFILL, AND THE INSTALLATION REQUIREMENTS SHALL ENSURE THAT THE LOAD FACTORS SPECIFIED IN THE AASHTO LRFD BRIDGE DESIGN SPECIFICATIONS, SECTION 12.12, ARE MET FOR: 1) LONG-DURATION DEAD LOADS AND 2) SHORT-DURATION LIVE LOADS, BASED ON THE CSA S6 CL-625 TRUCK AND THE AASHTO DESIGN TRUCK WITH CONSIDERATION FOR IMPACT AND MULTIPLE VEHICLE PRESENCES.
- CHAMBERS SHALL BE DESIGNED, TESTED AND ALLOWABLE LOAD CONFIGURATIONS DETERMINED IN ACCORDANCE WITH ASTM F2787, "STANDARD PRACTICE FOR STRUCTURAL DESIGN OF THERMOPLASTIC CORRUGATED WALL STORMWATER COLLECTION CHAMBERS". LOAD CONFIGURATIONS SHALL INCLUDE: 1) INSTANTANEOUS (<1 MIN) AASHTO DESIGN TRUCK LIVE LOAD ON MINIMUM COVER 2) MAXIMUM PERMANENT (75-YR) COVER LOAD AND 3) ALLOWABLE COVER WITH PARKED (1-WEEK) AASHTO DESIGN TRUCK.
- REQUIREMENTS FOR HANDLING AND INSTALLATION:
 - TO MAINTAIN THE WIDTH OF CHAMBERS DURING SHIPPING AND HANDLING, CHAMBERS SHALL HAVE INTEGRAL, INTERLOCKING STACKING LUGS.
 - TO ENSURE A SECURE JOINT DURING INSTALLATION AND BACKFILL, THE HEIGHT OF THE CHAMBER JOINT SHALL NOT BE LESS THAN 50 mm (2").
 - TO ENSURE THE INTEGRITY OF THE ARCH SHAPE DURING INSTALLATION, a) THE ARCH STIFFNESS CONSTANT SHALL BE GREATER THAN OR EQUAL TO 550 LBS/FT/%. THE ASC IS DEFINED IN SECTION 6.2.8 OF ASTM F2418. AND b) TO RESIST CHAMBER DEFORMATION DURING INSTALLATION AT ELEVATED TEMPERATURES (ABOVE 23° C / 73° F), CHAMBERS SHALL BE PRODUCED FROM REFLECTIVE GOLD OR YELLOW COLORS.
- ONLY CHAMBERS THAT ARE APPROVED BY THE SITE DESIGN ENGINEER WILL BE ALLOWED. UPON REQUEST BY THE SITE DESIGN ENGINEER OR OWNER, THE CHAMBER MANUFACTURER SHALL SUBMIT A STRUCTURAL EVALUATION FOR APPROVAL BEFORE DELIVERING CHAMBERS TO THE PROJECT SITE AS FOLLOWS:
 - THE STRUCTURAL EVALUATION SHALL BE SEALED BY A REGISTERED PROFESSIONAL ENGINEER.
 - THE STRUCTURAL EVALUATION SHALL DEMONSTRATE THAT THE SAFETY FACTORS ARE GREATER THAN OR EQUAL TO 1.95 FOR DEAD LOAD AND 1.75 FOR LIVE LOAD, THE MINIMUM REQUIRED BY ASTM F2787 AND BY SECTIONS 3 AND 12.12 OF THE AASHTO LRFD BRIDGE DESIGN SPECIFICATIONS FOR THERMOPLASTIC PIPE.
 - THE TEST DERIVED CREEP MODULUS AS SPECIFIED IN ASTM F2418 SHALL BE USED FOR PERMANENT DEAD LOAD DESIGN EXCEPT THAT IT SHALL BE THE 75-YEAR MODULUS USED FOR DESIGN.
- CHAMBERS AND END CAPS SHALL BE PRODUCED AT AN ISO 9001 CERTIFIED MANUFACTURING FACILITY.
- MANIFOLD SIZE TO BE DETERMINED BY SITE DESIGN ENGINEER. SEE TECHNICAL NOTE 6.32 FOR MANIFOLD SIZING GUIDANCE. DUE TO THE ADAPTATION OF THIS CHAMBER SYSTEM TO SPECIFIC SITE AND DESIGN CONSTRAINTS, IT MAY BE NECESSARY TO CUT AND COUPLE ADDITIONAL PIPE TO STANDARD MANIFOLD COMPONENTS IN THE FIELD.
- ADS DOES NOT DESIGN OR PROVIDE MEMBRANE LINER SYSTEMS. TO MINIMIZE THE LEAKAGE POTENTIAL OF LINER SYSTEMS, THE MEMBRANE LINER SYSTEM SHOULD BE DESIGNED BY A KNOWLEDGEABLE GEOTEXTILE PROFESSIONAL AND INSTALLED BY A QUALIFIED CONTRACTOR.

IMPORTANT - NOTES FOR THE BIDDING AND INSTALLATION OF THE DC-780 CHAMBER SYSTEM

- STORMTECH DC-780 CHAMBERS SHALL NOT BE INSTALLED UNTIL THE MANUFACTURER'S REPRESENTATIVE HAS COMPLETED A PRE-CONSTRUCTION MEETING WITH THE INSTALLERS.
- STORMTECH DC-780 CHAMBERS SHALL BE INSTALLED IN ACCORDANCE WITH THE "STORMTECH SC-310/SC-740/SC-800/DC-780 CONSTRUCTION GUIDE".
- CHAMBERS ARE NOT TO BE BACKFILLED WITH A DOZER OR AN EXCAVATOR SITUATED OVER THE CHAMBERS. STORMTECH RECOMMENDS 3 BACKFILL METHODS:
 - STONESHOOTER LOCATED OFF THE CHAMBER BED.
 - BACKFILL AS ROWS ARE BUILT USING AN EXCAVATOR ON THE FOUNDATION STONE OR SUBGRADE.
 - BACKFILL FROM OUTSIDE THE EXCAVATION USING A LONG BOOM HOE OR EXCAVATOR.
- THE FOUNDATION STONE SHALL BE LEVELED AND COMPACTED PRIOR TO PLACING CHAMBERS.
- JOINTS BETWEEN CHAMBERS SHALL BE PROPERLY SEATED PRIOR TO PLACING STONE.
- MAINTAIN MINIMUM - 150 mm (6") SPACING BETWEEN THE CHAMBER ROWS.
- EMBEDMENT STONE SURROUNDING CHAMBERS MUST BE A CLEAN, CRUSHED, ANGULAR STONE OR RECYCLED CONCRETE; AASHTO M43 #3, 357, 4, 467, 5, 56, OR 57.
- THE CONTRACTOR MUST REPORT ANY DISCREPANCIES WITH CHAMBER FOUNDATION MATERIALS BEARING CAPACITIES TO THE SITE DESIGN ENGINEER.
- ADS RECOMMENDS THE USE OF "FLEXSTORM CATCH IT" INSERTS DURING CONSTRUCTION FOR ALL INLETS TO PROTECT THE SUBSURFACE STORMWATER MANAGEMENT SYSTEM FROM CONSTRUCTION SITE RUNOFF.

NOTES FOR CONSTRUCTION EQUIPMENT

- STORMTECH DC-780 CHAMBERS SHALL BE INSTALLED IN ACCORDANCE WITH THE "STORMTECH SC-310/SC-740/SC-800/DC-780 CONSTRUCTION GUIDE".
- THE USE OF CONSTRUCTION EQUIPMENT OVER DC-780 CHAMBERS IS LIMITED:
 - NO EQUIPMENT IS ALLOWED ON BARE CHAMBERS.
 - NO RUBBER Tired LOADERS, DUMP TRUCKS, OR EXCAVATORS ARE ALLOWED UNTIL PROPER FILL DEPTHS ARE REACHED IN ACCORDANCE WITH THE "STORMTECH SC-310/SC-740/SC-800/DC-780 CONSTRUCTION GUIDE".
 - WEIGHT LIMITS FOR CONSTRUCTION EQUIPMENT CAN BE FOUND IN THE "STORMTECH SC-310/SC-740/SC-800/DC-780 CONSTRUCTION GUIDE".
- FULL 900 mm (36") OF STABILIZED COVER MATERIALS OVER THE CHAMBERS IS REQUIRED FOR DUMP TRUCK TRAVEL OR DUMPING.

USE OF A DOZER TO PUSH EMBEDMENT STONE BETWEEN THE ROWS OF CHAMBERS MAY CAUSE DAMAGE TO THE CHAMBERS AND IS NOT AN ACCEPTABLE BACKFILL METHOD. ANY CHAMBERS DAMAGED BY THE "DUMP AND PUSH" METHOD ARE NOT COVERED UNDER THE STORMTECH STANDARD WARRANTY.

CONTACT STORMTECH AT 1-800-821-6710 WITH ANY QUESTIONS ON INSTALLATION REQUIREMENTS OR WEIGHT LIMITS FOR CONSTRUCTION EQUIPMENT.

PROPOSED LAYOUT - STORMTECH 1

3	STORMTECH DC-780 CHAMBERS
2	STORMTECH DC-780 END CAPS
152	STONE ABOVE (mm)
229	STONE BELOW (mm)
40	% STONE VOID
9.1	INSTALLED SYSTEM VOLUME (m³) (PERIMETER STONE INCLUDED)
14.5	SYSTEM AREA (m²)
19.0	SYSTEM PERIMETER (m)

PROPOSED ELEVATIONS - STORMTECH 1

96.211	MAXIMUM ALLOWABLE GRADE (TOP OF PAVEMENT/UNPAVED)
93.163	MINIMUM ALLOWABLE GRADE (UNPAVED WITH TRAFFIC)
93.010	MINIMUM ALLOWABLE GRADE (UNPAVED NO TRAFFIC)
93.010	MINIMUM ALLOWABLE GRADE (BASE OF FLEXIBLE PAVEMENT)
93.010	MINIMUM ALLOWABLE GRADE (TOP OF RIGID PAVEMENT)
92.705	TOP OF STONE
92.553	TOP OF DC-780 CHAMBER
91.893	INSERTA TEE SIDE INLET CONNECTION INVERT
91.794	600 mm ISOLATOR ROW PLUS CONNECTION INVERT
91.791	BOTTOM OF DC-780 CHAMBER
91.562	BOTTOM OF STONE

NOTES

- THE SITE DESIGN ENGINEER MUST REVIEW ELEVATIONS AND IF NECESSARY ADJUST GRADING TO ENSURE THE CHAMBER COVER REQUIREMENTS ARE MET.
- THIS PLAN REFLECTS THE CHAMBER SYSTEM DESIGN BY THE SITE DESIGN ENGINEER USING STORMTECH COMPONENTS. THE SUITABILITY OF THE CHAMBER SYSTEM TO MEET ANY FUNCTIONAL REQUIREMENTS ARE THE RESPONSIBILITY OF THE SITE DESIGN ENGINEER. STORMTECH'S SCOPE OF WORK IS LIMITED TO THE ASSEMBLED PRODUCT DIMENSIONS AND SPECIFICATIONS FOR INSTALLATION.
- THE STORMTECH SYSTEM DEPICTED DOES NOT CONTAIN PROPER WATER QUALITY MEASURES. ABSENCE OF WATER QUALITY MEASURES CAN RESULT IN UNTREATED STORMWATER. ADS RECOMMENDS THE USE OF ISOLATOR ROW PLUS AND AN UPSTREAM HIGH FLOW BYPASS ON ALL STORMTECH SYSTEMS TO PROPERLY DIRECT THE FIRST FLUSH.
- **NOT FOR CONSTRUCTION:** THIS LAYOUT IS FOR DIMENSIONAL PURPOSES ONLY TO PROVE CONCEPT & THE REQUIRED STORAGE VOLUME CAN BE ACHIEVED ON SITE.

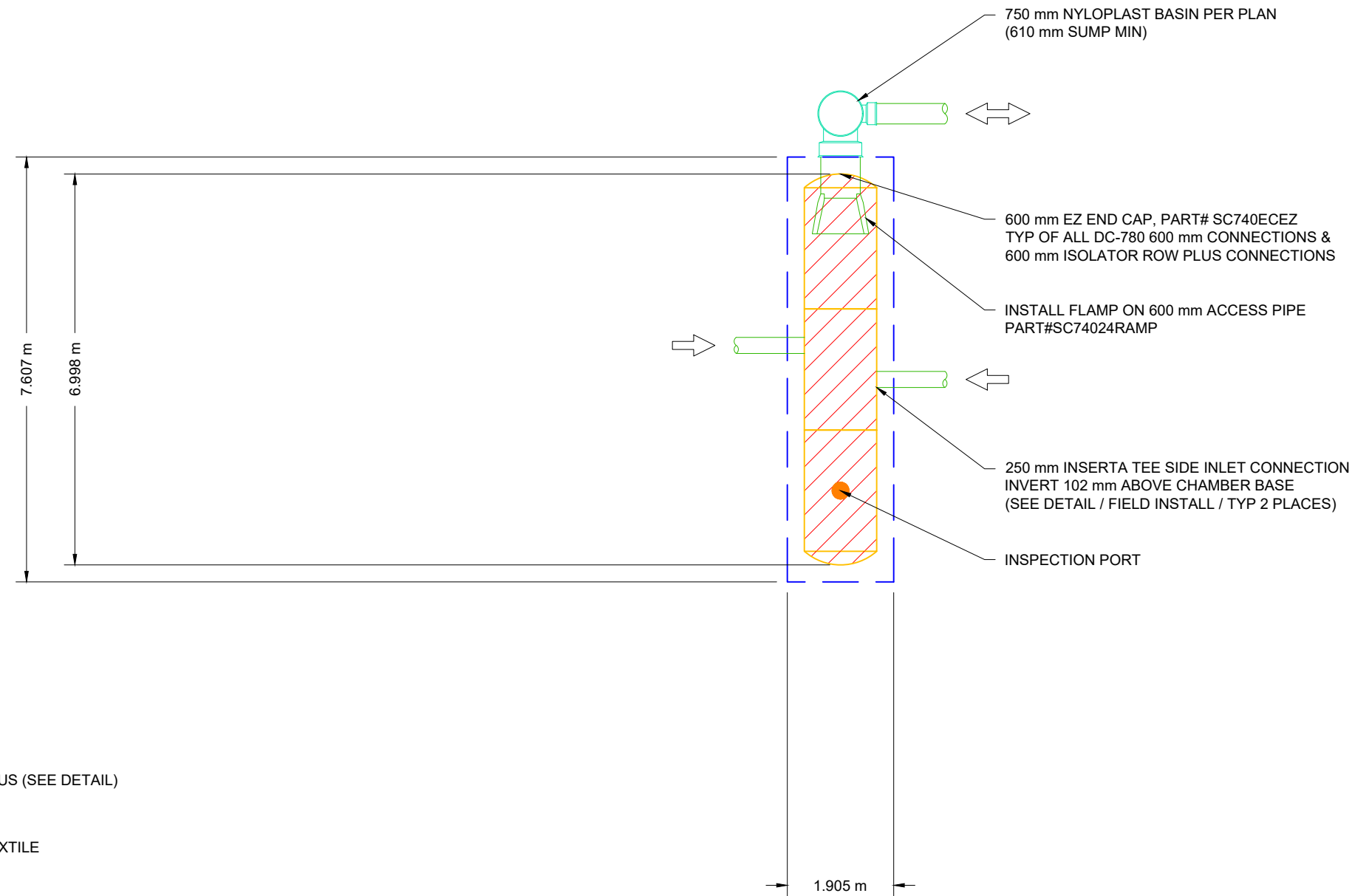

1398 BCDC
OTTAWA, ON.
DATE: 08/29/24
PROJECT #: S430138
DRAWN: JR
CHECKED: JR

DATE	DRWN	CHKD	DESCRIPTION

StormTech®
Chamber System
1-800-821-6710 | WWW.STORMTECH.COM

ADS
4640 TRUEMAN BLVD
HILLIARD, OH 43026

SCALE = 1 : 100

THIS DRAWING HAS BEEN PREPARED BASED ON INFORMATION PROVIDED TO ADS BY STORMTECH UNDER THE DIRECTION OF THE PROJECT'S ENGINEER OF RECORD (EOR) OR OTHER PROJECT REPRESENTATIVE. THIS DRAWING IS NOT INTENDED FOR USE IN BIDDING OR CONSTRUCTION WITHOUT THE EOR'S PRIOR APPROVAL. EOR SHALL REVIEW THIS DRAWING PRIOR TO BIDDING AND/OR CONSTRUCTION. IT IS THE ULTIMATE RESPONSIBILITY OF THE EOR TO ENSURE THAT THE PRODUCT(S) DEPICTED AND ALL ASSOCIATED DETAILS MEET ALL APPLICABLE LAWS, REGULATIONS, AND PROJECT REQUIREMENTS.

PROPOSED LAYOUT - STORMTECH 2

2	STORMTECH DC-780 CHAMBERS
2	STORMTECH DC-780 END CAPS
152	STONE ABOVE (mm)
229	STONE BELOW (mm)
40	% STONE VOID
6.4	INSTALLED SYSTEM VOLUME (m³) (PERIMETER STONE INCLUDED)
10.4	SYSTEM AREA (m²)
14.7	SYSTEM PERIMETER (m)

PROPOSED ELEVATIONS - STORMTECH 2

96.021	MAXIMUM ALLOWABLE GRADE (TOP OF PAVEMENT/UNPAVED)
92.973	MINIMUM ALLOWABLE GRADE (UNPAVED WITH TRAFFIC)
92.820	MINIMUM ALLOWABLE GRADE (UNPAVED NO TRAFFIC)
92.820	MINIMUM ALLOWABLE GRADE (BASE OF FLEXIBLE PAVEMENT)
92.820	MINIMUM ALLOWABLE GRADE (TOP OF RIGID PAVEMENT)
92.515	TOP OF STONE
92.363	TOP OF DC-780 CHAMBER
91.703	INSERTA TEE SIDE INLET CONNECTION INVERT
91.604	600 mm ISOLATOR ROW PLUS CONNECTION INVERT
91.601	BOTTOM OF DC-780 CHAMBER
91.372	BOTTOM OF STONE

NOTES

- THE SITE DESIGN ENGINEER MUST REVIEW ELEVATIONS AND IF NECESSARY ADJUST GRADING TO ENSURE THE CHAMBER COVER REQUIREMENTS ARE MET.
- THIS PLAN REFLECTS THE CHAMBER SYSTEM DESIGN BY THE SITE DESIGN ENGINEER USING STORMTECH COMPONENTS. THE SUITABILITY OF THE CHAMBER SYSTEM TO MEET ANY FUNCTIONAL REQUIREMENTS ARE THE RESPONSIBILITY OF THE SITE DESIGN ENGINEER. STORMTECH'S SCOPE OF WORK IS LIMITED TO THE ASSEMBLED PRODUCT DIMENSIONS AND SPECIFICATIONS FOR INSTALLATION.
- THE STORMTECH SYSTEM DEPICTED DOES NOT CONTAIN PROPER WATER QUALITY MEASURES. ABSENCE OF WATER QUALITY MEASURES CAN RESULT IN UNTREATED STORMWATER. ADS RECOMMENDS THE USE OF ISOLATOR ROW PLUS AND AN UPSTREAM HIGH FLOW BYPASS ON ALL STORMTECH SYSTEMS TO PROPERLY DIRECT THE FIRST FLUSH.
- **NOT FOR CONSTRUCTION:** THIS LAYOUT IS FOR DIMENSIONAL PURPOSES ONLY TO PROVE CONCEPT & THE REQUIRED STORAGE VOLUME CAN BE ACHIEVED ON SITE.

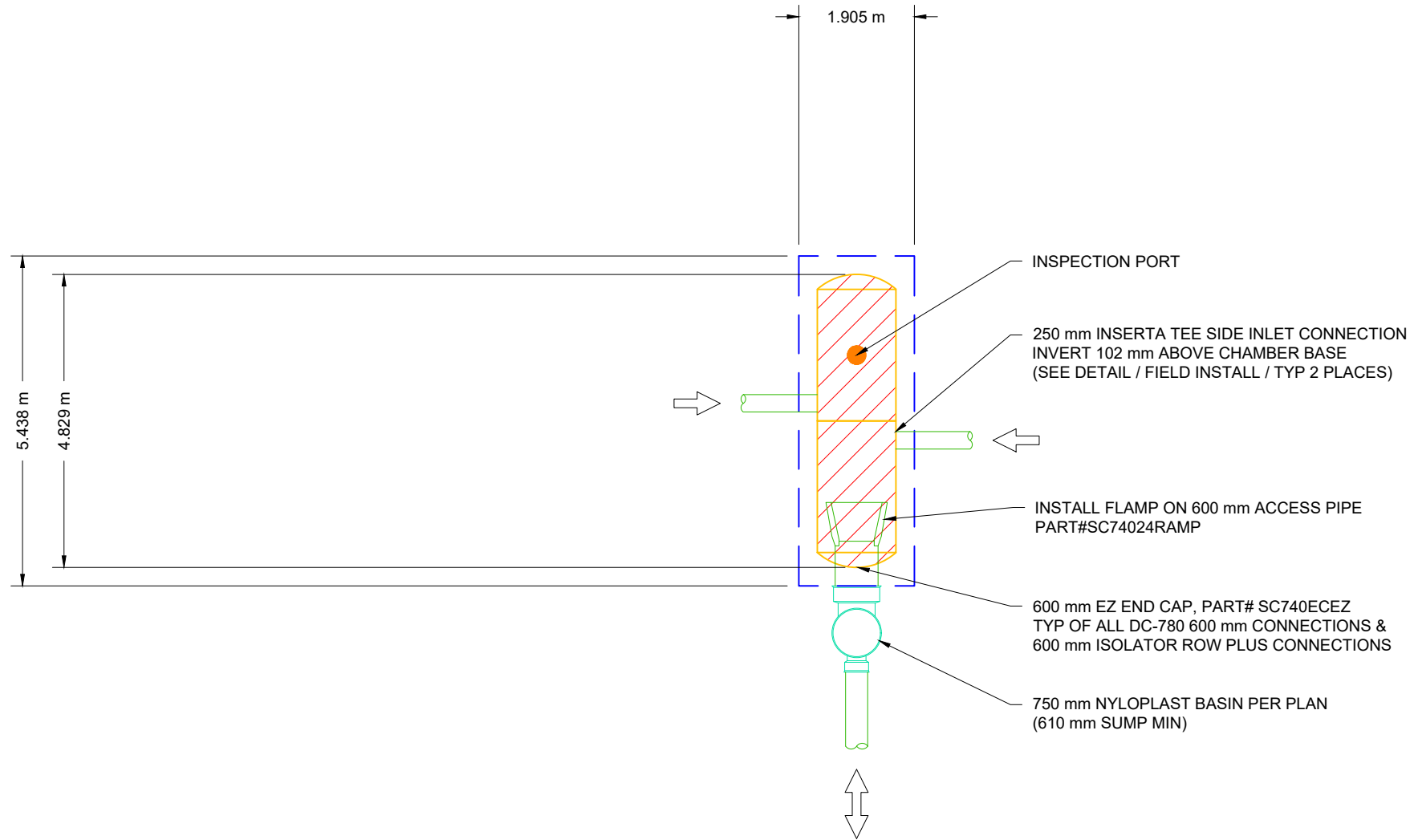

1398 BCDC

OTTAWA, ON.

DATE: 08/29/24 DRAWN: JR

PROJECT #: S430138 CHECKED: JR

DATE	DRWN	CHKD	DESCRIPTION

StormTech®
Chamber System

1-800-821-6710 | WWW.STORMTECH.COM

ADS
4640 TRUEMAN BLVD
HILLIARD, OH 43026

SCALE = 1 : 100

THIS DRAWING HAS BEEN PREPARED BASED ON INFORMATION PROVIDED TO ADS BY STORMTECH UNDER THE DIRECTION OF THE PROJECT'S ENGINEER OF RECORD (EOR) OR OTHER PROJECT REPRESENTATIVE. THIS DRAWING IS NOT INTENDED FOR USE IN BIDDING OR CONSTRUCTION WITHOUT THE EOR'S PRIOR APPROVAL. EOR SHALL REVIEW THIS DRAWING PRIOR TO BIDDING AND/OR CONSTRUCTION. IT IS THE ULTIMATE RESPONSIBILITY OF THE EOR TO ENSURE THAT THE PRODUCT(S) DEPICTED AND ALL ASSOCIATED DETAILS MEET ALL APPLICABLE LAWS, REGULATIONS, AND PROJECT REQUIREMENTS.

PROPOSED LAYOUT - STORMTECH 3

2	STORMTECH DC-780 CHAMBERS
2	STORMTECH DC-780 END CAPS
152	STONE ABOVE (mm)
229	STONE BELOW (mm)
40	% STONE VOID
6.4	INSTALLED SYSTEM VOLUME (m³) (PERIMETER STONE INCLUDED)
10.4	SYSTEM AREA (m²)
14.7	SYSTEM PERIMETER (m)

PROPOSED ELEVATIONS - STORMTECH 3

95.971	MAXIMUM ALLOWABLE GRADE (TOP OF PAVEMENT/UNPAVED)
92.923	MINIMUM ALLOWABLE GRADE (UNPAVED WITH TRAFFIC)
92.770	MINIMUM ALLOWABLE GRADE (UNPAVED NO TRAFFIC)
92.770	MINIMUM ALLOWABLE GRADE (BASE OF FLEXIBLE PAVEMENT)
92.770	MINIMUM ALLOWABLE GRADE (TOP OF RIGID PAVEMENT)
92.465	TOP OF STONE
92.313	TOP OF DC-780 CHAMBER
91.653	INSERTA TEE SIDE INLET CONNECTION INVERT
91.569	250 mm BOTTOM CONNECTION INVERT
91.554	600 mm ISOLATOR ROW PLUS CONNECTION INVERT
91.551	BOTTOM OF DC-780 CHAMBER
91.322	BOTTOM OF STONE

NOTES

- THE SITE DESIGN ENGINEER MUST REVIEW ELEVATIONS AND IF NECESSARY ADJUST GRADING TO ENSURE THE CHAMBER COVER REQUIREMENTS ARE MET.
- THIS PLAN REFLECTS THE CHAMBER SYSTEM DESIGN BY THE SITE DESIGN ENGINEER USING STORMTECH COMPONENTS. THE SUITABILITY OF THE CHAMBER SYSTEM TO MEET ANY FUNCTIONAL REQUIREMENTS ARE THE RESPONSIBILITY OF THE SITE DESIGN ENGINEER. STORMTECH'S SCOPE OF WORK IS LIMITED TO THE ASSEMBLED PRODUCT DIMENSIONS AND SPECIFICATIONS FOR INSTALLATION.
- THE STORMTECH SYSTEM DEPICTED DOES NOT CONTAIN PROPER WATER QUALITY MEASURES. ABSENCE OF WATER QUALITY MEASURES CAN RESULT IN UNTREATED STORMWATER. ADS RECOMMENDS THE USE OF ISOLATOR ROW PLUS AND AN UPSTREAM HIGH FLOW BYPASS ON ALL STORMTECH SYSTEMS TO PROPERLY DIRECT THE FIRST FLUSH.
- **NOT FOR CONSTRUCTION:** THIS LAYOUT IS FOR DIMENSIONAL PURPOSES ONLY TO PROVE CONCEPT & THE REQUIRED STORAGE VOLUME CAN BE ACHIEVED ON SITE.

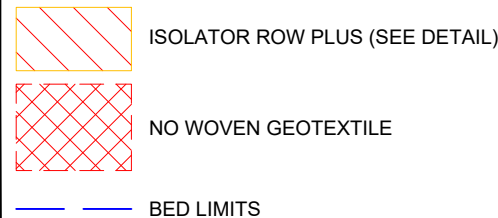
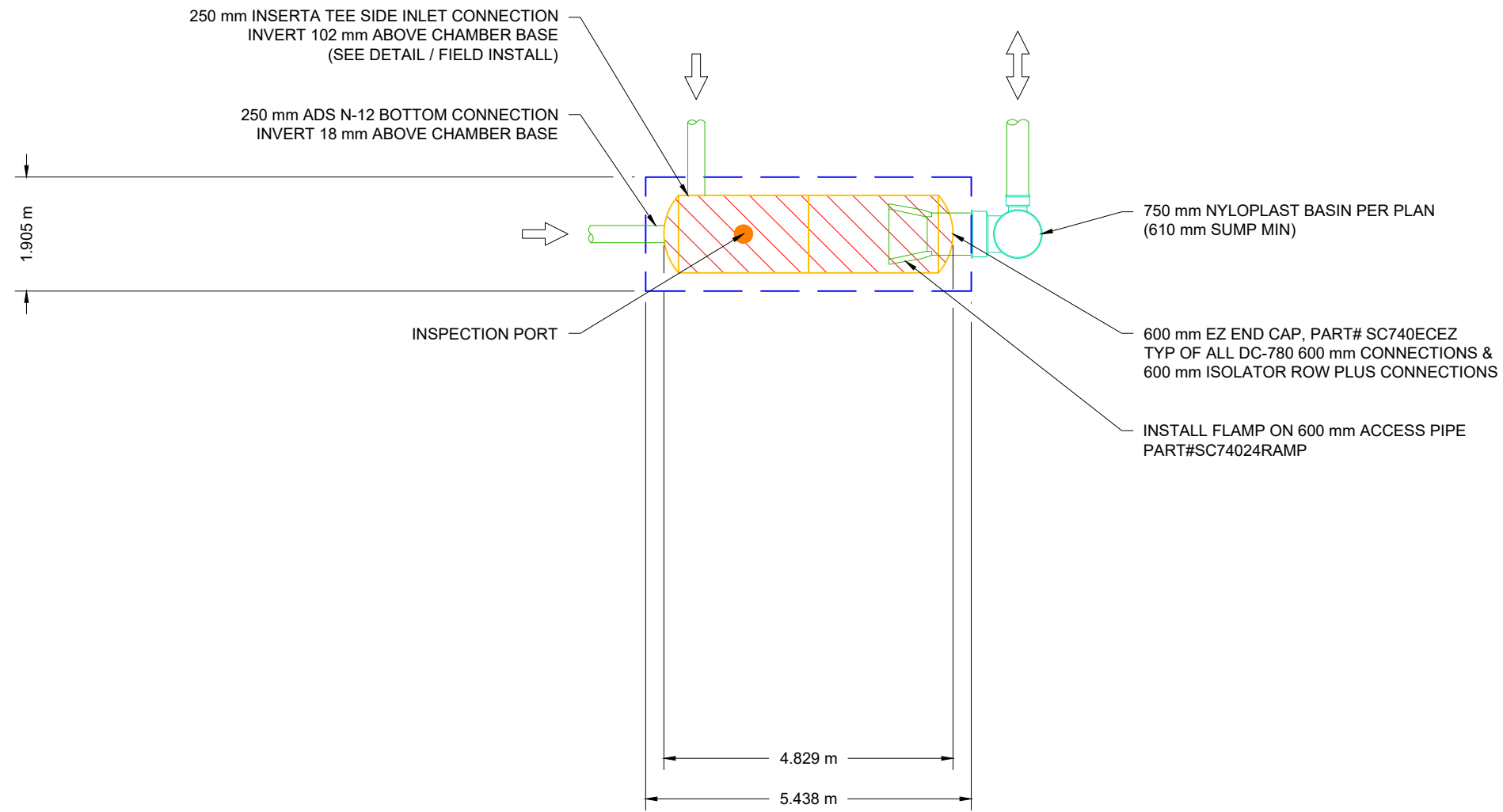

1398 BCDC

OTTAWA, ON.

DATE: 08/29/24 DRAWN: JR

PROJECT #: S430138 CHECKED: JR

DATE	DRWN	CHKD	DESCRIPTION

StormTech®
Chamber System
1-800-821-6710 | WWW.STORMTECH.COM

ADS
4640 TRUEMAN BLVD
HILLIARD, OH 43026

SCALE = 1 : 100

THIS DRAWING HAS BEEN PREPARED BASED ON INFORMATION PROVIDED TO ADS/STORMTECH UNDER THE DIRECTION OF THE PROJECT'S ENGINEER OF RECORD (EOR) OR OTHER PROJECT REPRESENTATIVE. THIS DRAWING IS NOT INTENDED FOR USE IN BIDDING OR CONSTRUCTION WITHOUT THE EOR'S PRIOR APPROVAL. EOR SHALL REVIEW THIS DRAWING PRIOR TO BIDDING AND/OR CONSTRUCTION. IT IS THE ULTIMATE RESPONSIBILITY OF THE EOR TO ENSURE THAT THE PRODUCT(S) DEPICTED AND ALL ASSOCIATED DETAILS MEET ALL APPLICABLE LAWS, REGULATIONS, AND PROJECT REQUIREMENTS.

PROPOSED LAYOUT - STORMTECH 4

2	STORMTECH DC-780 CHAMBERS
2	STORMTECH DC-780 END CAPS
152	STONE ABOVE (mm)
229	STONE BELOW (mm)
40	% STONE VOID
6.4	INSTALLED SYSTEM VOLUME (m³) (PERIMETER STONE INCLUDED)
10.4	SYSTEM AREA (m²)
14.7	SYSTEM PERIMETER (m)

PROPOSED ELEVATIONS - STORMTECH 4

96.121	MAXIMUM ALLOWABLE GRADE (TOP OF PAVEMENT/UNPAVED)
93.073	MINIMUM ALLOWABLE GRADE (UNPAVED WITH TRAFFIC)
92.920	MINIMUM ALLOWABLE GRADE (UNPAVED NO TRAFFIC)
92.920	MINIMUM ALLOWABLE GRADE (BASE OF FLEXIBLE PAVEMENT)
92.920	MINIMUM ALLOWABLE GRADE (TOP OF RIGID PAVEMENT)
92.615	TOP OF STONE
92.463	TOP OF DC-780 CHAMBER
91.803	INSERTA TEE SIDE INLET CONNECTION INVERT
91.704	600 mm ISOLATOR ROW PLUS CONNECTION INVERT
91.701	BOTTOM OF DC-780 CHAMBER
91.472	BOTTOM OF STONE

NOTES

- THE SITE DESIGN ENGINEER MUST REVIEW ELEVATIONS AND IF NECESSARY ADJUST GRADING TO ENSURE THE CHAMBER COVER REQUIREMENTS ARE MET.
- THIS PLAN REFLECTS THE CHAMBER SYSTEM DESIGN BY THE SITE DESIGN ENGINEER USING STORMTECH COMPONENTS. THE SUITABILITY OF THE CHAMBER SYSTEM TO MEET ANY FUNCTIONAL REQUIREMENTS ARE THE RESPONSIBILITY OF THE SITE DESIGN ENGINEER. STORMTECH'S SCOPE OF WORK IS LIMITED TO THE ASSEMBLED PRODUCT DIMENSIONS AND SPECIFICATIONS FOR INSTALLATION.
- THE STORMTECH SYSTEM DEPICTED DOES NOT CONTAIN PROPER WATER QUALITY MEASURES. ABSENCE OF WATER QUALITY MEASURES CAN RESULT IN UNTREATED STORMWATER. ADS RECOMMENDS THE USE OF ISOLATOR ROW PLUS AND AN UPSTREAM HIGH FLOW BYPASS ON ALL STORMTECH SYSTEMS TO PROPERLY DIRECT THE FIRST FLUSH.
- **NOT FOR CONSTRUCTION:** THIS LAYOUT IS FOR DIMENSIONAL PURPOSES ONLY TO PROVE CONCEPT & THE REQUIRED STORAGE VOLUME CAN BE ACHIEVED ON SITE.

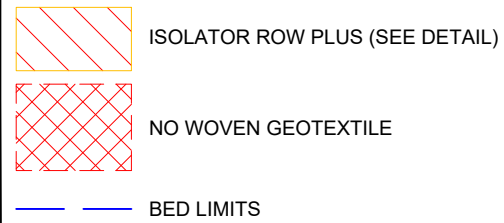
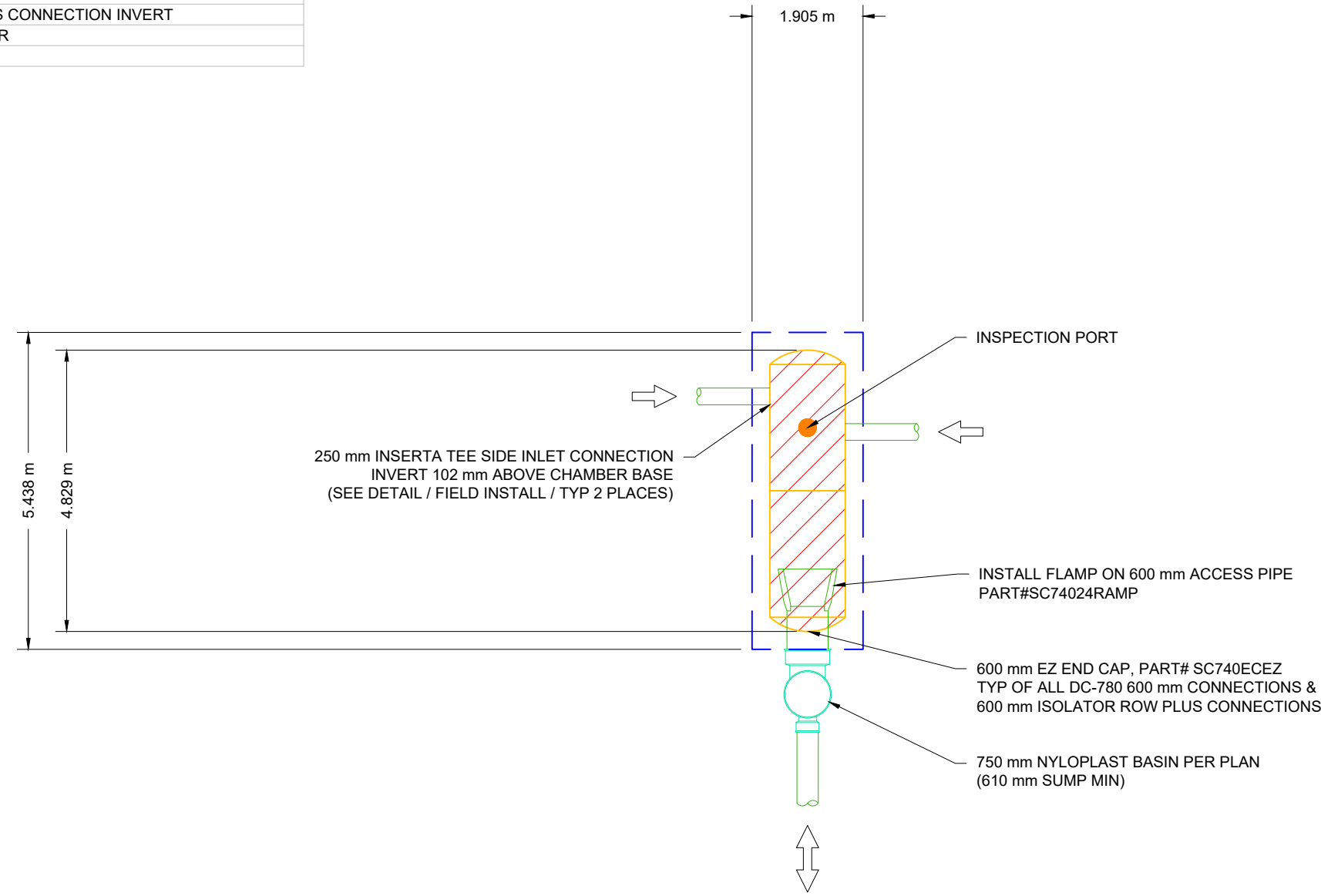

1398 BCDC
OTTAWA, ON.
DATE: 08/29/24
DRAWN: JR
PROJECT #: S430138
CHECKED: JR

DATE	DRWN	CHKD	DESCRIPTION

StormTech®
Chamber System
1-800-821-6710 | WWW.STORMTECH.COM

ADS
4640 TRUEMAN BLVD
HILLIARD, OH 43026

SCALE = 1 : 100

THIS DRAWING HAS BEEN PREPARED BASED ON INFORMATION PROVIDED TO ADS BY STORMTECH UNDER THE DIRECTION OF THE PROJECT'S ENGINEER OF RECORD (EOR) OR OTHER PROJECT REPRESENTATIVE. THIS DRAWING IS NOT INTENDED FOR USE IN BIDDING OR CONSTRUCTION WITHOUT THE EOR'S PRIOR APPROVAL. EOR SHALL REVIEW THIS DRAWING PRIOR TO BIDDING AND/OR CONSTRUCTION. IT IS THE ULTIMATE RESPONSIBILITY OF THE EOR TO ENSURE THAT THE PRODUCT(S) DEPICTED AND ALL ASSOCIATED DETAILS MEET ALL APPLICABLE LAWS, REGULATIONS, AND PROJECT REQUIREMENTS.

PROPOSED LAYOUT - STORMTECH 5

3	STORMTECH DC-780 CHAMBERS
2	STORMTECH DC-780 END CAPS
152	STONE ABOVE (mm)
229	STONE BELOW (mm)
40	% STONE VOID
9.1	INSTALLED SYSTEM VOLUME (m³) (PERIMETER STONE INCLUDED)
14.5	SYSTEM AREA (m²)
19.0	SYSTEM PERIMETER (m)

PROPOSED ELEVATIONS - STORMTECH 5

95.851	MAXIMUM ALLOWABLE GRADE (TOP OF PAVEMENT/UNPAVED)
92.803	MINIMUM ALLOWABLE GRADE (UNPAVED WITH TRAFFIC)
92.650	MINIMUM ALLOWABLE GRADE (UNPAVED NO TRAFFIC)
92.650	MINIMUM ALLOWABLE GRADE (BASE OF FLEXIBLE PAVEMENT)
92.650	MINIMUM ALLOWABLE GRADE (TOP OF RIGID PAVEMENT)
92.345	TOP OF STONE
92.193	TOP OF DC-780 CHAMBER
91.533	INSERTA TEE SIDE INLET CONNECTION INVERT
91.449	250 mm BOTTOM CONNECTION INVERT
91.434	600 mm ISOLATOR ROW PLUS CONNECTION INVERT
91.431	BOTTOM OF DC-780 CHAMBER
91.202	BOTTOM OF STONE

NOTES

- THE SITE DESIGN ENGINEER MUST REVIEW ELEVATIONS AND IF NECESSARY ADJUST GRADING TO ENSURE THE CHAMBER COVER REQUIREMENTS ARE MET.
- THIS PLAN REFLECTS THE CHAMBER SYSTEM DESIGN BY THE SITE DESIGN ENGINEER USING STORMTECH COMPONENTS. THE SUITABILITY OF THE CHAMBER SYSTEM TO MEET ANY FUNCTIONAL REQUIREMENTS ARE THE RESPONSIBILITY OF THE SITE DESIGN ENGINEER. STORMTECH'S SCOPE OF WORK IS LIMITED TO THE ASSEMBLED PRODUCT DIMENSIONS AND SPECIFICATIONS FOR INSTALLATION.
- THE STORMTECH SYSTEM DEPICTED DOES NOT CONTAIN PROPER WATER QUALITY MEASURES. ABSENCE OF WATER QUALITY MEASURES CAN RESULT IN UNTREATED STORMWATER. ADS RECOMMENDS THE USE OF ISOLATOR ROW PLUS AND AN UPSTREAM HIGH FLOW BYPASS ON ALL STORMTECH SYSTEMS TO PROPERLY DIRECT THE FIRST FLUSH.
- **NOT FOR CONSTRUCTION:** THIS LAYOUT IS FOR DIMENSIONAL PURPOSES ONLY TO PROVE CONCEPT & THE REQUIRED STORAGE VOLUME CAN BE ACHIEVED ON SITE.

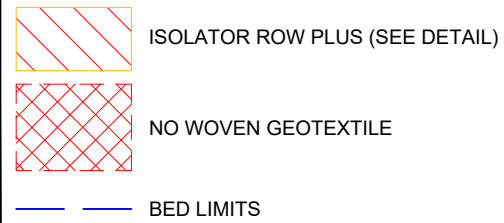
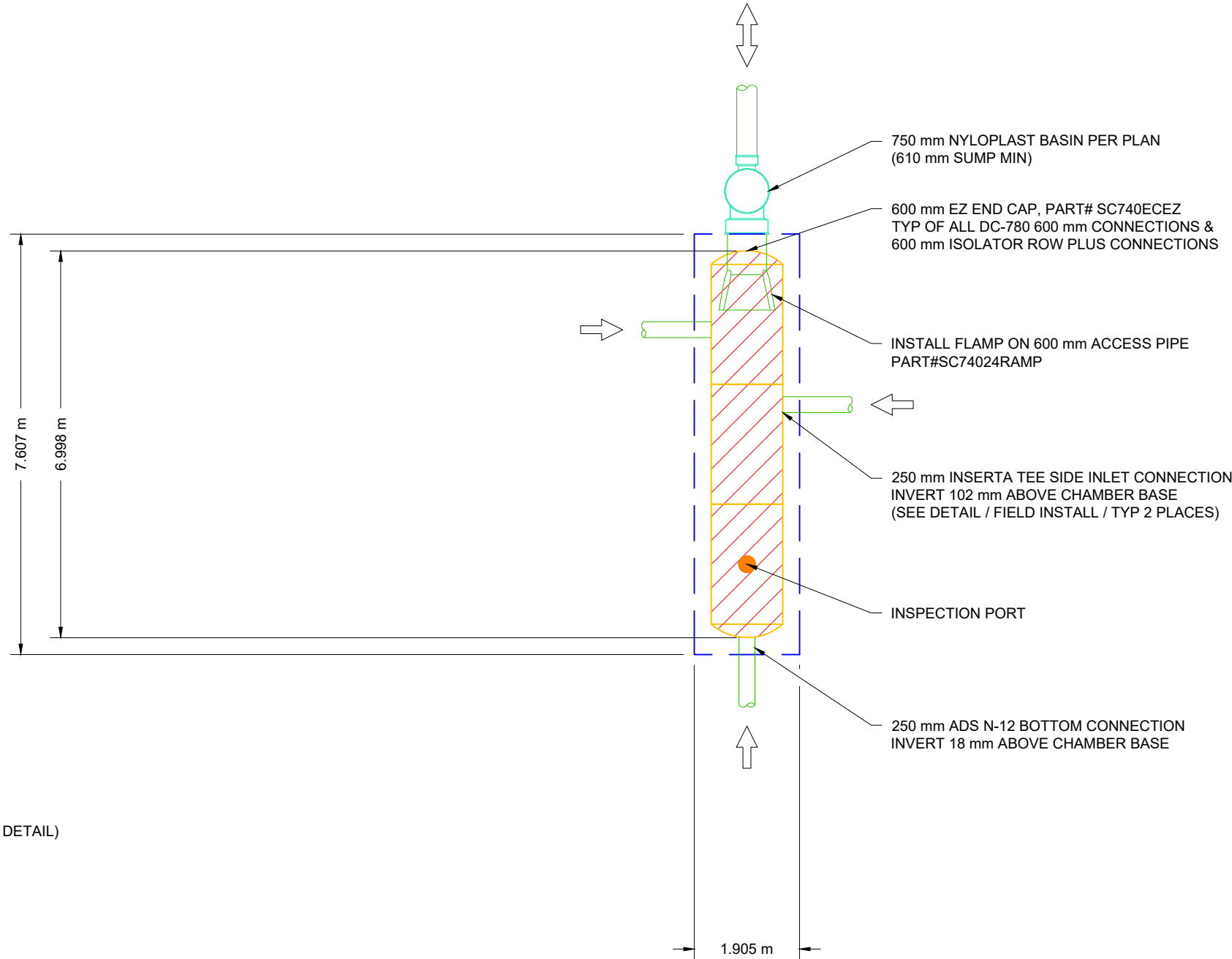

1398 BCDC	
OTTAWA, ON.	
DATE: 08/29/24	DRAWN: JR
PROJECT #: S430138	CHECKED: JR

DATE	DRWN	CHKD	DESCRIPTION

StormTech®
Chamber System
1-800-821-6710 | WWW.STORMTECH.COM

ADS
4640 TRUEMAN BLVD
HILLIARD, OH 43026

SCALE = 1 : 100

THIS DRAWING HAS BEEN PREPARED BASED ON INFORMATION PROVIDED TO ADS/STORMTECH UNDER THE DIRECTION OF THE PROJECT'S ENGINEER OF RECORD (EOR) OR OTHER PROJECT REPRESENTATIVE. THIS DRAWING IS NOT INTENDED FOR USE IN BIDDING OR CONSTRUCTION WITHOUT THE EOR'S PRIOR APPROVAL. EOR SHALL REVIEW THIS DRAWING PRIOR TO BIDDING AND/OR CONSTRUCTION. IT IS THE ULTIMATE RESPONSIBILITY OF THE EOR TO ENSURE THAT THE PRODUCT(S) DEPICTED AND ALL ASSOCIATED DETAILS MEET ALL APPLICABLE LAWS, REGULATIONS, AND PROJECT REQUIREMENTS.

PROPOSED LAYOUT - STORMTECH 6

3	STORMTECH DC-780 CHAMBERS
2	STORMTECH DC-780 END CAPS
152	STONE ABOVE (mm)
229	STONE BELOW (mm)
40	% STONE VOID
9.1	INSTALLED SYSTEM VOLUME (m³) (PERIMETER STONE INCLUDED)
14.5	SYSTEM AREA (m²)
19.0	SYSTEM PERIMETER (m)

PROPOSED ELEVATIONS - STORMTECH 6

95.991	MAXIMUM ALLOWABLE GRADE (TOP OF PAVEMENT/UNPAVED)
92.943	MINIMUM ALLOWABLE GRADE (UNPAVED WITH TRAFFIC)
92.790	MINIMUM ALLOWABLE GRADE (UNPAVED NO TRAFFIC)
92.790	MINIMUM ALLOWABLE GRADE (BASE OF FLEXIBLE PAVEMENT)
92.790	MINIMUM ALLOWABLE GRADE (TOP OF RIGID PAVEMENT)
92.485	TOP OF STONE
92.333	TOP OF DC-780 CHAMBER
91.673	INSERTA TEE SIDE INLET CONNECTION INVERT
91.589	250 mm BOTTOM CONNECTION INVERT
91.574	600 mm ISOLATOR ROW PLUS CONNECTION INVERT
91.571	BOTTOM OF DC-780 CHAMBER
91.342	BOTTOM OF STONE

NOTES

- THE SITE DESIGN ENGINEER MUST REVIEW ELEVATIONS AND IF NECESSARY ADJUST GRADING TO ENSURE THE CHAMBER COVER REQUIREMENTS ARE MET.
- THIS PLAN REFLECTS THE CHAMBER SYSTEM DESIGN BY THE SITE DESIGN ENGINEER USING STORMTECH COMPONENTS. THE SUITABILITY OF THE CHAMBER SYSTEM TO MEET ANY FUNCTIONAL REQUIREMENTS ARE THE RESPONSIBILITY OF THE SITE DESIGN ENGINEER. STORMTECH'S SCOPE OF WORK IS LIMITED TO THE ASSEMBLED PRODUCT DIMENSIONS AND SPECIFICATIONS FOR INSTALLATION.
- THE STORMTECH SYSTEM DEPICTED DOES NOT CONTAIN PROPER WATER QUALITY MEASURES. ABSENCE OF WATER QUALITY MEASURES CAN RESULT IN UNTREATED STORMWATER. ADS RECOMMENDS THE USE OF ISOLATOR ROW PLUS AND AN UPSTREAM HIGH FLOW BYPASS ON ALL STORMTECH SYSTEMS TO PROPERLY DIRECT THE FIRST FLUSH.
- **NOT FOR CONSTRUCTION:** THIS LAYOUT IS FOR DIMENSIONAL PURPOSES ONLY TO PROVE CONCEPT & THE REQUIRED STORAGE VOLUME CAN BE ACHIEVED ON SITE.

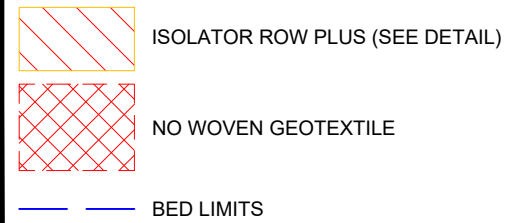
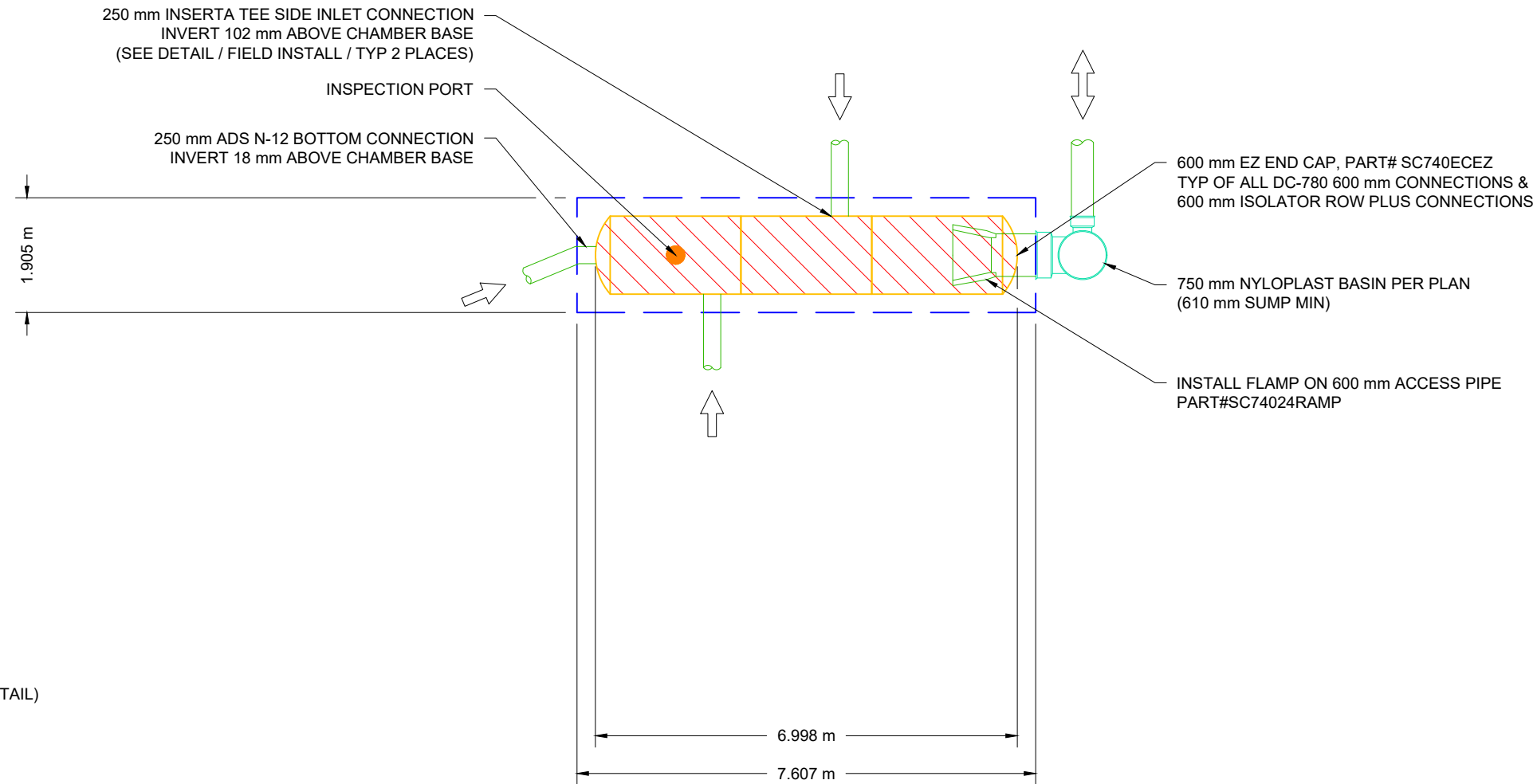

1398 BCDC	
OTTAWA, ON.	
DATE: 08/29/24	DRAWN: JR
PROJECT #: S430138	CHECKED: JR

DATE	DRWN	CHKD	DESCRIPTION

StormTech®
Chamber System
1-800-821-6710 | WWW.STORMTECH.COM

ADS 4640 TRUEMAN BLVD
HILLIARD, OH 43026

SCALE = 1 : 100

THIS DRAWING HAS BEEN PREPARED BASED ON INFORMATION PROVIDED TO ADS/STORMTECH UNDER THE DIRECTION OF THE PROJECT'S ENGINEER OF RECORD (EOR) OR OTHER PROJECT REPRESENTATIVE. THIS DRAWING IS NOT INTENDED FOR USE IN BIDDING OR CONSTRUCTION WITHOUT THE EOR'S PRIOR APPROVAL. EOR SHALL REVIEW THIS DRAWING PRIOR TO BIDDING AND/OR CONSTRUCTION. IT IS THE ULTIMATE RESPONSIBILITY OF THE EOR TO ENSURE THAT THE PRODUCT(S) DEPICTED AND ALL ASSOCIATED DETAILS MEET ALL APPLICABLE LAWS, REGULATIONS, AND PROJECT REQUIREMENTS.

PROPOSED LAYOUT - STORMTECH 7

3	STORMTECH DC-780 CHAMBERS
2	STORMTECH DC-780 END CAPS
152	STONE ABOVE (mm)
229	STONE BELOW (mm)
40	% STONE VOID
9.1	INSTALLED SYSTEM VOLUME (m³) (PERIMETER STONE INCLUDED)
14.5	SYSTEM AREA (m²)
19.0	SYSTEM PERIMETER (m)

PROPOSED ELEVATIONS - STORMTECH 7

95.941	MAXIMUM ALLOWABLE GRADE (TOP OF PAVEMENT/UNPAVED)
92.893	MINIMUM ALLOWABLE GRADE (UNPAVED WITH TRAFFIC)
92.740	MINIMUM ALLOWABLE GRADE (UNPAVED NO TRAFFIC)
92.740	MINIMUM ALLOWABLE GRADE (BASE OF FLEXIBLE PAVEMENT)
92.740	MINIMUM ALLOWABLE GRADE (TOP OF RIGID PAVEMENT)
92.435	TOP OF STONE
92.283	TOP OF DC-780 CHAMBER
91.623	INSERTA TEE SIDE INLET CONNECTION INVERT
91.524	600 mm ISOLATOR ROW PLUS CONNECTION INVERT
91.521	BOTTOM OF DC-780 CHAMBER
91.292	BOTTOM OF STONE

NOTES

- THE SITE DESIGN ENGINEER MUST REVIEW ELEVATIONS AND IF NECESSARY ADJUST GRADING TO ENSURE THE CHAMBER COVER REQUIREMENTS ARE MET.
- THIS PLAN REFLECTS THE CHAMBER SYSTEM DESIGN BY THE SITE DESIGN ENGINEER USING STORMTECH COMPONENTS. THE SUITABILITY OF THE CHAMBER SYSTEM TO MEET ANY FUNCTIONAL REQUIREMENTS ARE THE RESPONSIBILITY OF THE SITE DESIGN ENGINEER. STORMTECH'S SCOPE OF WORK IS LIMITED TO THE ASSEMBLED PRODUCT DIMENSIONS AND SPECIFICATIONS FOR INSTALLATION.
- THE STORMTECH SYSTEM DEPICTED DOES NOT CONTAIN PROPER WATER QUALITY MEASURES. ABSENCE OF WATER QUALITY MEASURES CAN RESULT IN UNTREATED STORMWATER. ADS RECOMMENDS THE USE OF ISOLATOR ROW PLUS AND AN UPSTREAM HIGH FLOW BYPASS ON ALL STORMTECH SYSTEMS TO PROPERLY DIRECT THE FIRST FLUSH.
- **NOT FOR CONSTRUCTION:** THIS LAYOUT IS FOR DIMENSIONAL PURPOSES ONLY TO PROVE CONCEPT & THE REQUIRED STORAGE VOLUME CAN BE ACHIEVED ON SITE.

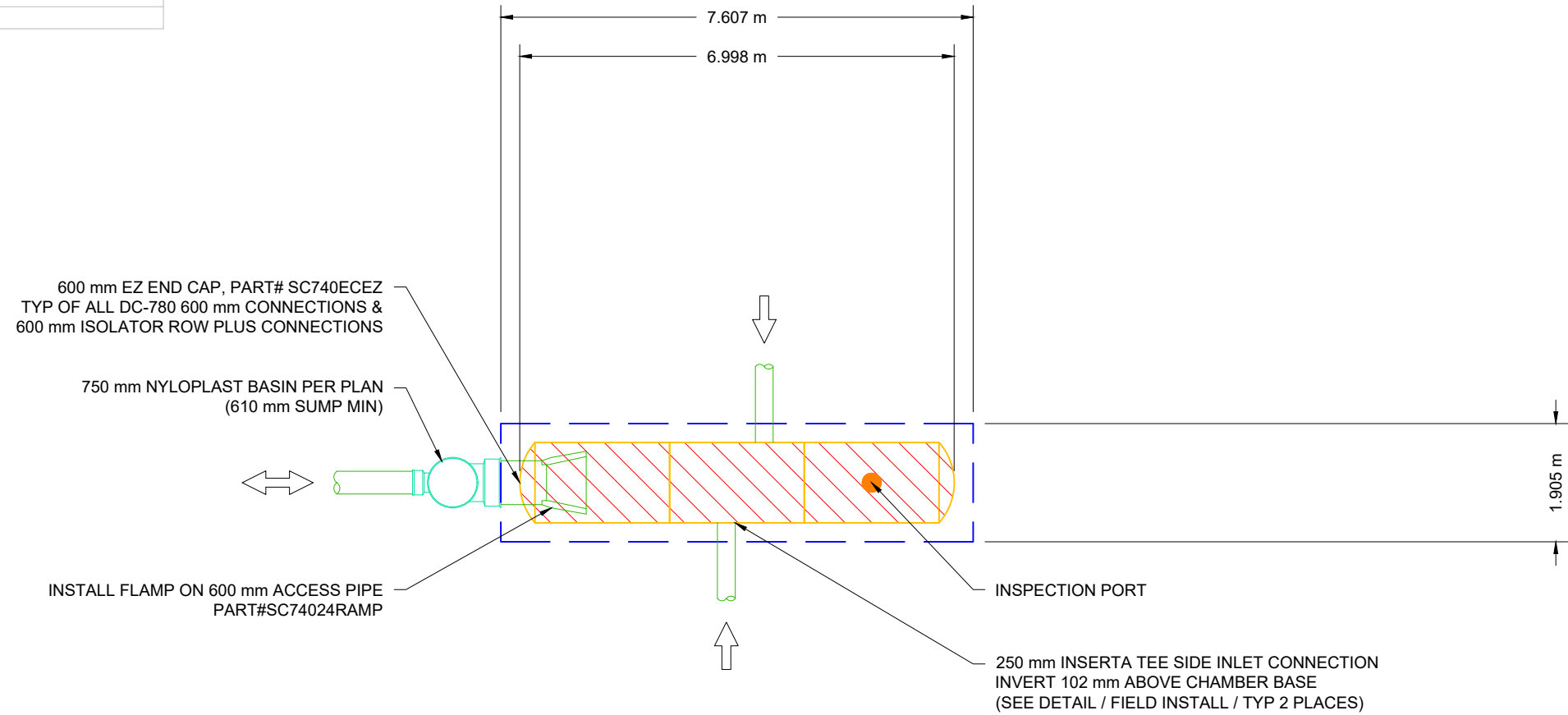

- ISOLATOR ROW PLUS (SEE DETAIL)
- NO WOVEN GEOTEXTILE
- BED LIMITS

1398 BCDC	
OTTAWA, ON.	
DATE: 08/29/24	DRAWN: JR
PROJECT #: S430138	CHECKED: JR

DATE	DRWN	CHKD	DESCRIPTION

StormTech®
Chamber System
1-800-821-6710 | WWW.STORMTECH.COM

ADS 4640 TRUEMAN BLVD
HILLIARD, OH 43026

SCALE = 1 : 100

THIS DRAWING HAS BEEN PREPARED BASED ON INFORMATION PROVIDED TO ADS/STORMTECH UNDER THE DIRECTION OF THE PROJECT'S ENGINEER OF RECORD (EOR) OR OTHER PROJECT REPRESENTATIVE. THIS DRAWING IS NOT INTENDED FOR USE IN BIDDING OR CONSTRUCTION WITHOUT THE EOR'S PRIOR APPROVAL. EOR SHALL REVIEW THIS DRAWING PRIOR TO BIDDING AND/OR CONSTRUCTION. IT IS THE ULTIMATE RESPONSIBILITY OF THE EOR TO ENSURE THAT THE PRODUCT(S) DEPICTED AND ALL ASSOCIATED DETAILS MEET ALL APPLICABLE LAWS, REGULATIONS, AND PROJECT REQUIREMENTS.

ACCEPTABLE FILL MATERIALS: STORMTECH DC-780 CHAMBER SYSTEMS

MATERIAL LOCATION	DESCRIPTION	AASHTO MATERIAL CLASSIFICATIONS	COMPACTION / DENSITY REQUIREMENT
D	FINAL FILL: FILL MATERIAL FOR LAYER 'D' STARTS FROM THE TOP OF THE 'C' LAYER TO THE BOTTOM OF FLEXIBLE PAVEMENT OR UNPAVED FINISHED GRADE ABOVE. NOTE THAT PAVEMENT SUBBASE MAY BE PART OF THE 'D' LAYER	N/A	PREPARE PER SITE DESIGN ENGINEER'S PLANS. PAVED INSTALLATIONS MAY HAVE STRINGENT MATERIAL AND PREPARATION REQUIREMENTS.
C	INITIAL FILL: FILL MATERIAL FOR LAYER 'C' STARTS FROM THE TOP OF THE EMBEDMENT STONE ('B' LAYER) TO 18" (450 mm) ABOVE THE TOP OF THE CHAMBER. NOTE THAT PAVEMENT SUBBASE MAY BE A PART OF THE 'C' LAYER.	AASHTO M145 ¹ A-1, A-2-4, A-3 OR AASHTO M43 ¹ 3, 357, 4, 467, 5, 56, 57, 6, 67, 68, 7, 78, 8, 89, 9, 10	BEGIN COMPACTIONS AFTER 12" (300 mm) OF MATERIAL OVER THE CHAMBERS IS REACHED. COMPACT ADDITIONAL LAYERS IN 6" (150 mm) MAX LIFTS TO A MIN. 95% PROCTOR DENSITY FOR WELL GRADED MATERIAL AND 95% RELATIVE DENSITY FOR PROCESSED AGGREGATE MATERIALS. ROLLER GROSS VEHICLE WEIGHT NOT TO EXCEED 12,000 lbs (53 kN). DYNAMIC FORCE NOT TO EXCEED 20,000 lbs (89 kN).
B	EMBEDMENT STONE: FILL SURROUNDING THE CHAMBERS FROM THE FOUNDATION STONE ('A' LAYER) TO THE 'C' LAYER ABOVE.	AASHTO M43 ¹ 3, 357, 4, 467, 5, 56, 57	NO COMPACTION REQUIRED.
A	FOUNDATION STONE: FILL BELOW CHAMBERS FROM THE SUBGRADE UP TO THE FOOT (BOTTOM) OF THE CHAMBER.	AASHTO M43 ¹ 3, 357, 4, 467, 5, 56, 57	PLATE COMPACT OR ROLL TO ACHIEVE A FLAT SURFACE. ^{2,3}

PLEASE NOTE:

- THE LISTED AASHTO DESIGNATIONS ARE FOR GRADATIONS ONLY. THE STONE MUST ALSO BE CLEAN, CRUSHED, ANGULAR. FOR EXAMPLE, A SPECIFICATION FOR #4 STONE WOULD STATE: "CLEAN, CRUSHED, ANGULAR NO. 4 (AASHTO M43) STONE".
- STORMTECH COMPACTION REQUIREMENTS ARE MET FOR 'A' LOCATION MATERIALS WHEN PLACED AND COMPACTED IN 9" (230 mm) (MAX) LIFTS USING TWO FULL COVERAGES WITH A VIBRATORY COMPACTOR.
- WHERE INFILTRATION SURFACES MAY BE COMPROMISED BY COMPACTION, FOR STANDARD DESIGN LOAD CONDITIONS, A FLAT SURFACE MAY BE ACHIEVED BY RAKING OR DRAGGING WITHOUT COMPACTION EQUIPMENT. FOR SPECIAL LOAD DESIGNS, CONTACT STORMTECH FOR COMPACTION REQUIREMENTS.
- ONCE LAYER 'C' IS PLACED, ANY SOIL/MATERIAL CAN BE PLACED IN LAYER 'D' UP TO THE FINISHED GRADE. MOST PAVEMENT SUBBASE SOILS CAN BE USED TO REPLACE THE MATERIAL REQUIREMENTS OF LAYER 'C' OR 'D' AT THE SITE DESIGN ENGINEER'S DISCRETION.
- WHERE RECYCLED CONCRETE AGGREGATE IS USED IN LAYERS 'A' OR 'B' THE MATERIAL SHOULD ALSO MEET THE ACCEPTABILITY CRITERIA OUTLINED IN TECHNICAL NOTE 6.20 "RECYCLED CONCRETE STRUCTURAL BACKFILL".

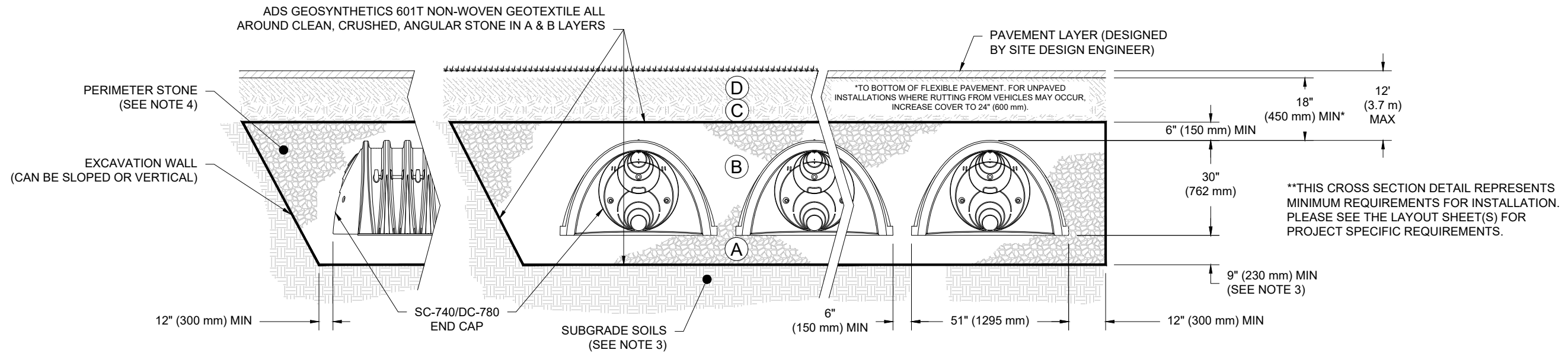

NOTES:

- CHAMBERS SHALL MEET THE REQUIREMENTS OF ASTM F2418, "STANDARD SPECIFICATION FOR POLYPROPYLENE (PP) CORRUGATED WALL STORMWATER COLLECTION CHAMBERS".
- DC-780 CHAMBERS SHALL BE DESIGNED IN ACCORDANCE WITH ASTM F2787 "STANDARD PRACTICE FOR STRUCTURAL DESIGN OF THERMOPLASTIC CORRUGATED WALL STORMWATER COLLECTION CHAMBERS".
- THE SITE DESIGN ENGINEER IS RESPONSIBLE FOR ASSESSING THE BEARING RESISTANCE (ALLOWABLE BEARING CAPACITY) OF THE SUBGRADE SOILS AND THE DEPTH OF FOUNDATION STONE WITH CONSIDERATION FOR THE RANGE OF EXPECTED SOIL MOISTURE CONDITIONS. REFERENCE STORMTECH DESIGN MANUAL FOR BEARING CAPACITY GUIDANCE.
- PERIMETER STONE MUST BE EXTENDED HORIZONTALLY TO THE EXCAVATION WALL FOR BOTH VERTICAL AND SLOPED EXCAVATION WALLS.
- REQUIREMENTS FOR HANDLING AND INSTALLATION:
 - TO MAINTAIN THE WIDTH OF CHAMBERS DURING SHIPPING AND HANDLING, CHAMBERS SHALL HAVE INTEGRAL, INTERLOCKING STACKING LUGS.
 - TO ENSURE A SECURE JOINT DURING INSTALLATION AND BACKFILL, THE HEIGHT OF THE CHAMBER JOINT SHALL NOT BE LESS THAN 2".
 - TO ENSURE THE INTEGRITY OF THE ARCH SHAPE DURING INSTALLATION, a) THE ARCH STIFFNESS CONSTANT AS DEFINED IN SECTION 6.2.8 OF ASTM F2418 SHALL BE GREATER THAN OR EQUAL TO 550 LBS/FT%. AND b) TO RESIST CHAMBER DEFORMATION DURING INSTALLATION AT ELEVATED TEMPERATURES (ABOVE 73° F / 23° C), CHAMBERS SHALL BE PRODUCED FROM REFLECTIVE GOLD OR YELLOW COLORS.

1398 BCDC

OTTAWA, ON.

DATE: 08/29/24

DRAWN: JR

PROJECT #: S430138

CHECKED: JR

DATE	DRWN	CHKD	DESCRIPTION

StormTech®
Chamber System

1-800-821-6710 | WWW.STORMTECH.COM

4640 TRUEMAN BLVD
HILLIARD, OH 43026



THIS DRAWING HAS BEEN PREPARED BASED ON INFORMATION PROVIDED TO ADS BY STORMTECH UNDER THE DIRECTION OF THE PROJECT'S ENGINEER OF RECORD (EOR) OR OTHER PROJECT REPRESENTATIVE. THIS DRAWING IS NOT INTENDED FOR USE IN BIDDING OR CONSTRUCTION WITHOUT THE EOR'S PRIOR APPROVAL. EOR SHALL REVIEW THIS DRAWING PRIOR TO BIDDING AND/OR CONSTRUCTION. IT IS THE ULTIMATE RESPONSIBILITY OF THE EOR TO ENSURE THAT THE PRODUCT(S) DEPICTED AND ALL ASSOCIATED DETAILS MEET ALL APPLICABLE LAWS, REGULATIONS, AND PROJECT REQUIREMENTS.

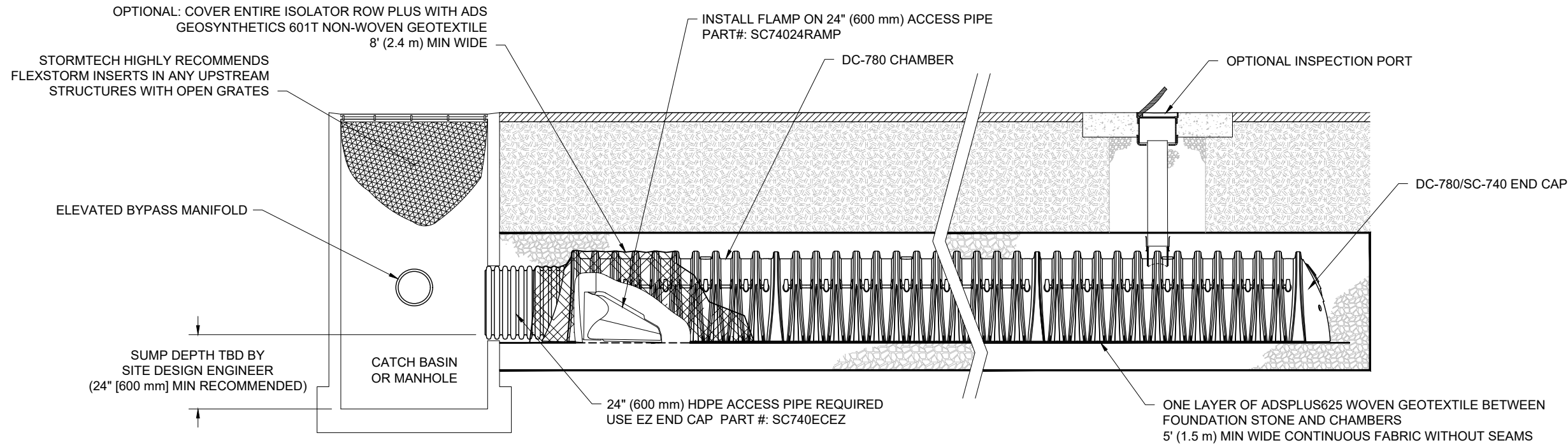

DC-780 ISOLATOR ROW PLUS DETAIL
NTS

INSPECTION & MAINTENANCE

- STEP 1) INSPECT ISOLATOR ROW PLUS FOR SEDIMENT
- A. INSPECTION PORTS (IF PRESENT)
 - A.1. REMOVE/OPEN LID ON NYLOPLAST INLINE DRAIN
 - A.2. REMOVE AND CLEAN FLEXSTORM FILTER IF INSTALLED
 - A.3. USING A FLASHLIGHT AND STADIA ROD, MEASURE DEPTH OF SEDIMENT AND RECORD ON MAINTENANCE LOG
 - A.4. LOWER A CAMERA INTO ISOLATOR ROW PLUS FOR VISUAL INSPECTION OF SEDIMENT LEVELS (OPTIONAL)
 - A.5. IF SEDIMENT IS AT, OR ABOVE, 3" (80 mm) PROCEED TO STEP 2. IF NOT, PROCEED TO STEP 3.
 - B. ALL ISOLATOR PLUS ROWS
 - B.1. REMOVE COVER FROM STRUCTURE AT UPSTREAM END OF ISOLATOR ROW PLUS
 - B.2. USING A FLASHLIGHT, INSPECT DOWN THE ISOLATOR ROW PLUS THROUGH OUTLET PIPE
 - i) MIRRORS ON POLES OR CAMERAS MAY BE USED TO AVOID A CONFINED SPACE ENTRY
 - ii) FOLLOW OSHA REGULATIONS FOR CONFINED SPACE ENTRY IF ENTERING MANHOLE
 - B.3. IF SEDIMENT IS AT, OR ABOVE, 3" (80 mm) PROCEED TO STEP 2. IF NOT, PROCEED TO STEP 3.
- STEP 2) CLEAN OUT ISOLATOR ROW PLUS USING THE JETVAC PROCESS
- A. A FIXED CULVERT CLEANING NOZZLE WITH REAR FACING SPREAD OF 45" (1.1 m) OR MORE IS PREFERRED
 - B. APPLY MULTIPLE PASSES OF JETVAC UNTIL BACKFLUSH WATER IS CLEAN
 - C. VACUUM STRUCTURE SUMP AS REQUIRED
- STEP 3) REPLACE ALL COVERS, GRATES, FILTERS, AND LIDS; RECORD OBSERVATIONS AND ACTIONS.
- STEP 4) INSPECT AND CLEAN BASINS AND MANHOLES UPSTREAM OF THE STORMTECH SYSTEM.

NOTES

1. INSPECT EVERY 6 MONTHS DURING THE FIRST YEAR OF OPERATION. ADJUST THE INSPECTION INTERVAL BASED ON PREVIOUS OBSERVATIONS OF SEDIMENT ACCUMULATION AND HIGH WATER ELEVATIONS.
2. CONDUCT JETTING AND VACTORING ANNUALLY OR WHEN INSPECTION SHOWS THAT MAINTENANCE IS NECESSARY.

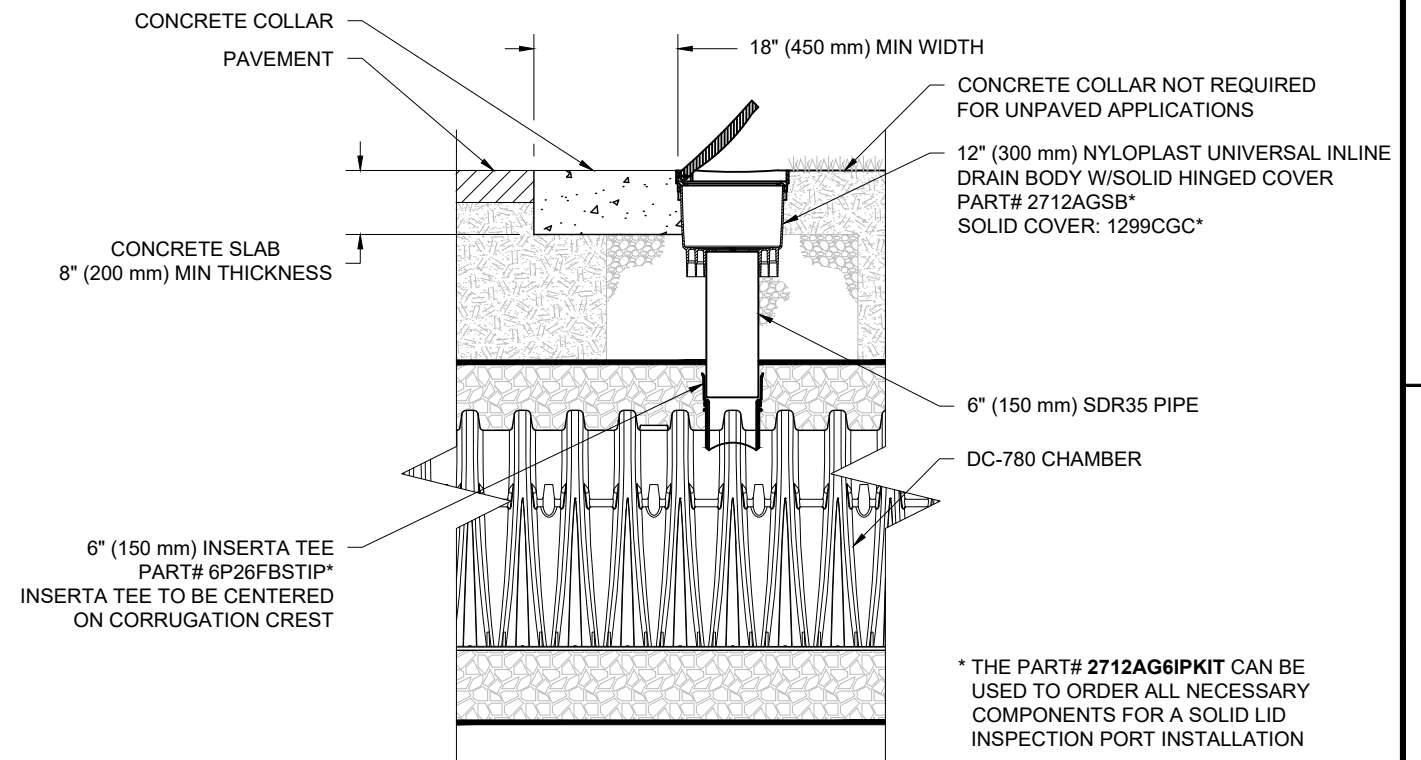

DC-780 6" (150 mm) INSPECTION PORT DETAIL
NTS

1398 BCDC	OTTAWA, ON.	DATE: 08/29/24	DRAWN: JR	PROJECT #: S430138	CHECKED: JR
		DATE	DRWN	CHKD	DESCRIPTION
StormTech® Chamber System		1-800-821-6710 WWW.STORMTECH.COM			
4640 TRUEJMAN BLVD HILLIARD, OH 43026					
ADS					
THIS DRAWING HAS BEEN PREPARED BASED ON INFORMATION PROVIDED TO ADS/STORMTECH UNDER THE DIRECTION OF THE PROJECT'S ENGINEER OF RECORD (EOR) OR OTHER PROJECT REPRESENTATIVE. THIS DRAWING IS NOT INTENDED FOR USE IN BIDDING OR CONSTRUCTION WITHOUT THE EOR'S PRIOR APPROVAL. EOR SHALL REVIEW THIS DRAWING PRIOR TO BIDDING AND/OR CONSTRUCTION. IT IS THE ULTIMATE RESPONSIBILITY OF THE EOR TO ENSURE THAT THE PRODUCT(S) DEPICTED AND ALL ASSOCIATED DETAILS MEET ALL APPLICABLE LAWS, REGULATIONS, AND PROJECT REQUIREMENTS.					
10		SHEET		OF 11	

DC-780 TECHNICAL SPECIFICATION

NTS

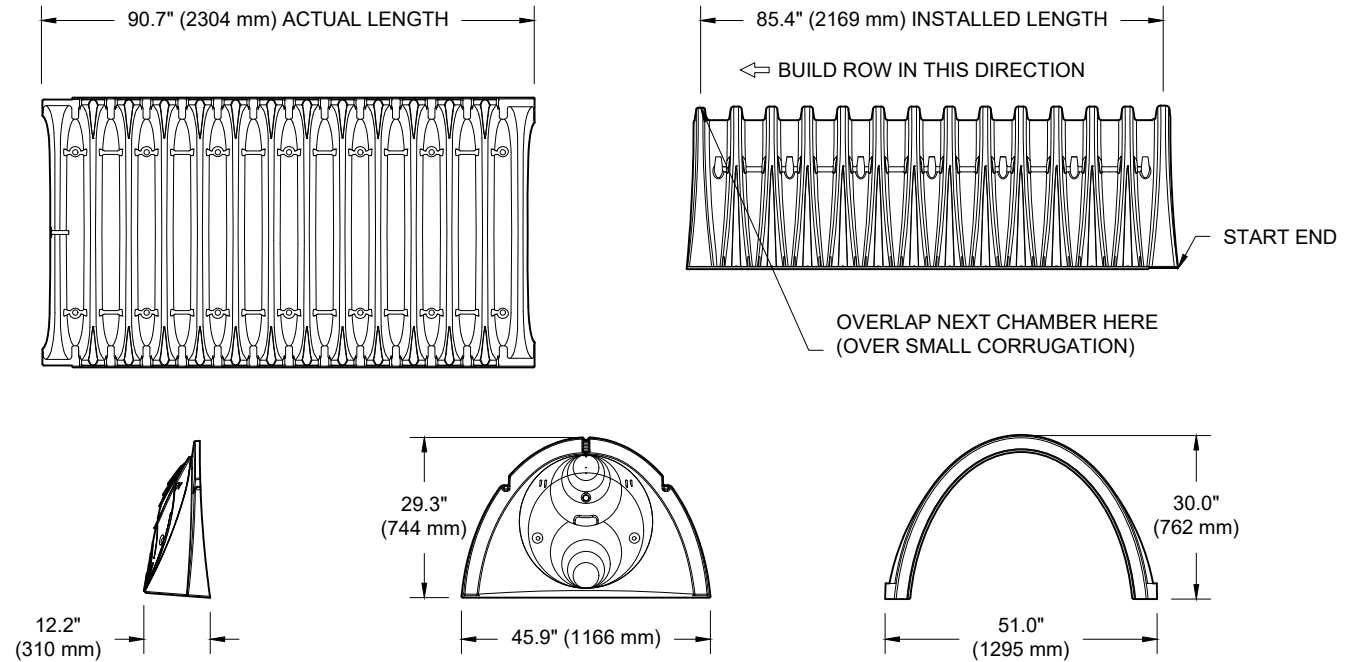

NOMINAL CHAMBER SPECIFICATIONS

SIZE (W X H X INSTALLED LENGTH)	51.0" X 30.0" X 85.4"	(1295 mm X 762 mm X 2169 mm)
CHAMBER STORAGE	46.2 CUBIC FEET	(1.30 m ³)
MINIMUM INSTALLED STORAGE*	78.4 CUBIC FEET	(2.20 m ³)
WEIGHT	75.0 lbs.	(33.6 kg)

NOMINAL END CAP SPECIFICATIONS

SIZE (W X H X INSTALLED LENGTH)	45.9" X 29.3" X 9.6"	(1166 mm X 744 mm X 244 mm)
END CAP STORAGE	2.6 CUBIC FEET	(0.07 m ³)
MINIMUM INSTALLED STORAGE**	14.4 CUBIC FEET	(0.40 m ³)
WEIGHT	11.7 lbs.	(5.3 kg)

* ASSUMES 6" (152 mm) STONE ABOVE, 9" (229 mm) BELOW, AND 6" (152 mm) BETWEEN CHAMBERS

**ASSUMES 6" (152 mm) STONE ABOVE, 9" (229 mm) BELOW END CAPS, 6" (152 mm) BETWEEN ROWS, 12" (305 mm) BEYOND END CAPS

PRE-FAB STUBS AT BOTTOM OF END CAP FOR PART NUMBERS ENDING WITH "B"
 PRE-FAB STUBS AT TOP OF END CAP FOR PART NUMBERS ENDING WITH "T"
 PRE-CORED END CAPS END WITH "PC"

PART #	STUB	A	B	C
SC740EPE06T / SC740EPE06TPC	6" (150 mm)	10.9" (277 mm)	18.5" (470 mm)	---
SC740EPE06B / SC740EPE06BPC			---	0.5" (13 mm)
SC740EPE08T / SC740EPE08TPC	8" (200 mm)	12.2" (310 mm)	16.5" (419 mm)	---
SC740EPE08B / SC740EPE08BPC			---	0.6" (15 mm)
SC740EPE10T / SC740EPE10TPC	10" (250 mm)	13.4" (340 mm)	14.5" (368 mm)	---
SC740EPE10B / SC740EPE10BPC			---	0.7" (18 mm)
SC740EPE12T / SC740EPE12TPC	12" (300 mm)	14.7" (373 mm)	12.5" (318 mm)	---
SC740EPE12B / SC740EPE12BPC			---	1.2" (30 mm)
SC740EPE15T / SC740EPE15TPC	15" (375 mm)	18.4" (467 mm)	9.0" (229 mm)	---
SC740EPE15B / SC740EPE15BPC			---	1.3" (33 mm)
SC740EPE18T / SC740EPE18TPC	18" (450 mm)	19.7" (500 mm)	5.0" (127 mm)	---
SC740EPE18B / SC740EPE18BPC			---	1.6" (41 mm)
SC740ECEZ*	24" (600 mm)	18.5" (470 mm)	---	0.1" (3 mm)

ALL STUBS, EXCEPT FOR THE SC740ECEZ ARE PLACED AT BOTTOM OF END CAP SUCH THAT THE OUTSIDE DIAMETER OF THE STUB IS FLUSH WITH THE BOTTOM OF THE END CAP. FOR ADDITIONAL INFORMATION CONTACT STORMTECH AT 1-888-892-2694.

* FOR THE SC740ECEZ THE 24" (600 mm) STUB LIES BELOW THE BOTTOM OF THE END CAP APPROXIMATELY 1.75" (44 mm). BACKFILL MATERIAL SHOULD BE REMOVED FROM BELOW THE N-12 STUB SO THAT THE FITTING SITS LEVEL.

NOTE: ALL DIMENSIONS ARE NOMINAL

INSERTA TEE DETAIL

NTS

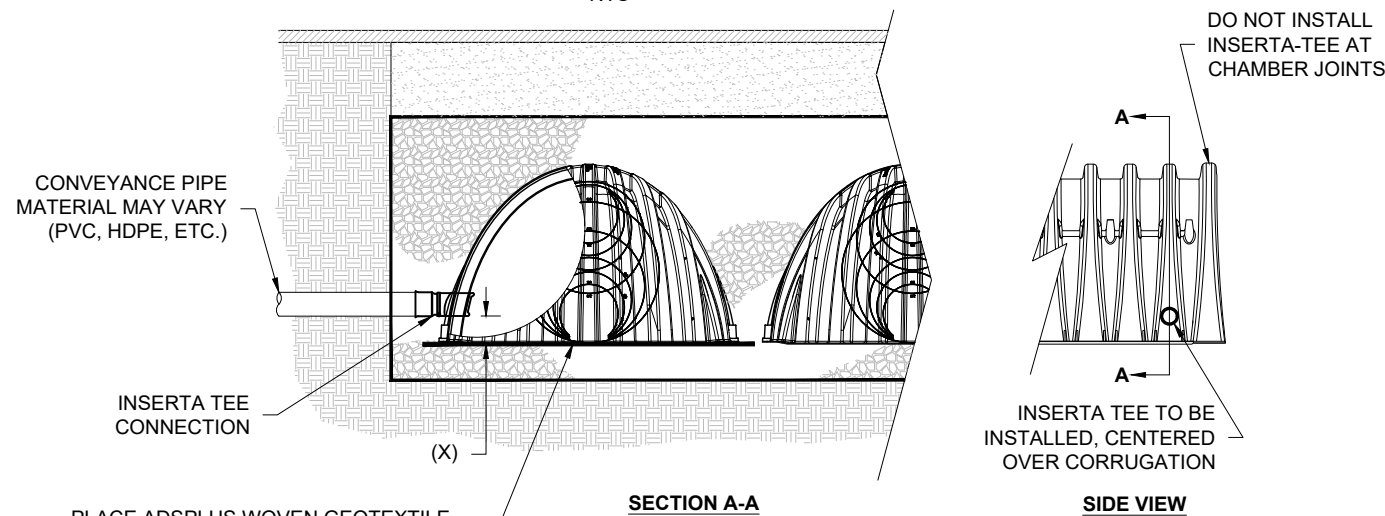

PLACE ADSPLUS WOVEN GEOTEXTILE (CENTERED ON INSERTA-TEE INLET) OVER BEDDING STONE FOR SCOUR PROTECTION AT SIDE INLET CONNECTIONS. GEOTEXTILE MUST EXTEND 6" (150 mm) PAST CHAMBER FOOT

CHAMBER	MAX DIAMETER OF INSERTA TEE	HEIGHT FROM BASE OF CHAMBER (X)
SC-310	6" (150 mm)	4" (100 mm)
SC-740	10" (250 mm)	4" (100 mm)
SC-800	10" (250 mm)	4" (100 mm)
DC-780	10" (250 mm)	4" (100 mm)
MC-3500	12" (300 mm)	6" (150 mm)
MC-4500	12" (300 mm)	8" (200 mm)
MC-7200	12" (300 mm)	8" (200 mm)

INSERTA TEE FITTINGS AVAILABLE FOR SDR 26, SDR 35, SCH 40 IPS GASKETED & SOLVENT WELD, N-12, HP STORM, C-900 OR DUCTILE IRON

NOTES:

- PART NUMBERS WILL VARY BASED ON INLET PIPE MATERIALS. CONTACT STORMTECH FOR MORE INFORMATION.
- CONTACT ADS ENGINEERING SERVICES IF INSERTA TEE INLET MUST BE RAISED AS NOT ALL INVERTS ARE POSSIBLE.

1398 BCDC

OTTAWA, ON.

DATE: 08/29/24 DRAWN: JR

PROJECT #: S430138 CHECKED: JR

DATE	DRWN	CHKD	DESCRIPTION

StormTech®
Chamber System

1-800-821-6710 | WWW.STORMTECH.COM

4640 TRUEMAN BLVD
HILLIARD, OH 43026

ADS

THIS DRAWING HAS BEEN PREPARED BASED ON INFORMATION PROVIDED TO ADS/STORMTECH UNDER THE DIRECTION OF THE PROJECT'S ENGINEER OF RECORD (EOR) OR OTHER PROJECT REPRESENTATIVE. THIS DRAWING IS NOT INTENDED FOR USE IN BIDDING OR CONSTRUCTION WITHOUT THE EOR'S PRIOR APPROVAL. EOR SHALL REVIEW THIS DRAWING PRIOR TO BIDDING AND/OR CONSTRUCTION. IT IS THE ULTIMATE RESPONSIBILITY OF THE EOR TO ENSURE THAT THE PRODUCT(S) DEPICTED AND ALL ASSOCIATED DETAILS MEET ALL APPLICABLE LAWS, REGULATIONS, AND PROJECT REQUIREMENTS.

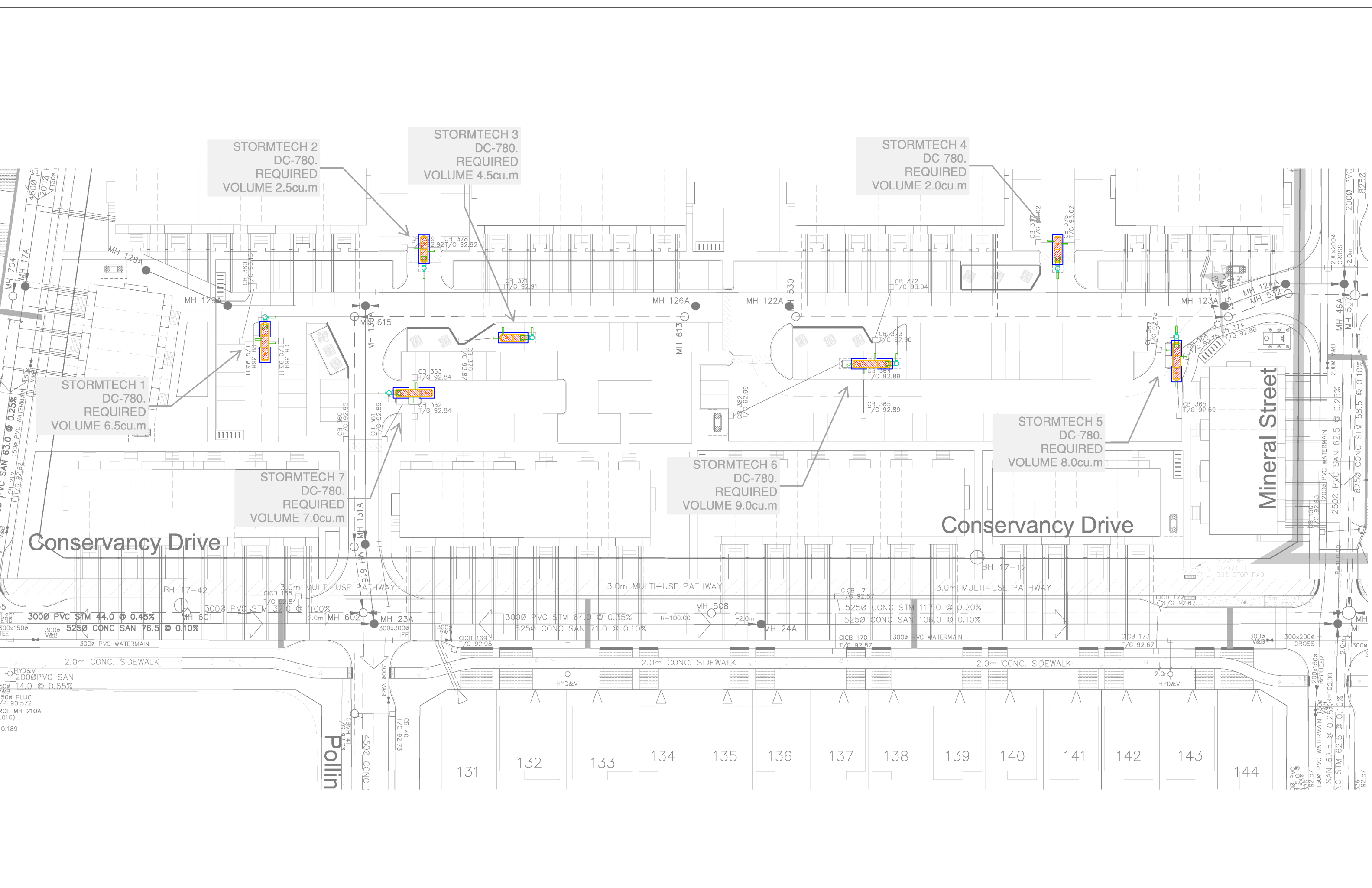

STORMTECH 2
DC-780.
REQUIRED
VOLUME 2.5cu.m

STORMTECH 3
DC-780.
REQUIRED
VOLUME 4.5cu.m

STORMTECH 4
DC-780.
REQUIRED
VOLUME 2.0cu.m

STORMTECH 1
DC-780.
REQUIRED
VOLUME 6.5cu.m

STORMTECH 7
DC-780.
REQUIRED
VOLUME 7.0cu.m

STORMTECH 6
DC-780.
REQUIRED
VOLUME 9.0cu.m

STORMTECH 5
DC-780.
REQUIRED
VOLUME 8.0cu.m

Conservancy Drive

Conservancy Drive

Mineral Street

Pollin

131

132

133

134

135

136

137

138

139

140

141

142

143

144

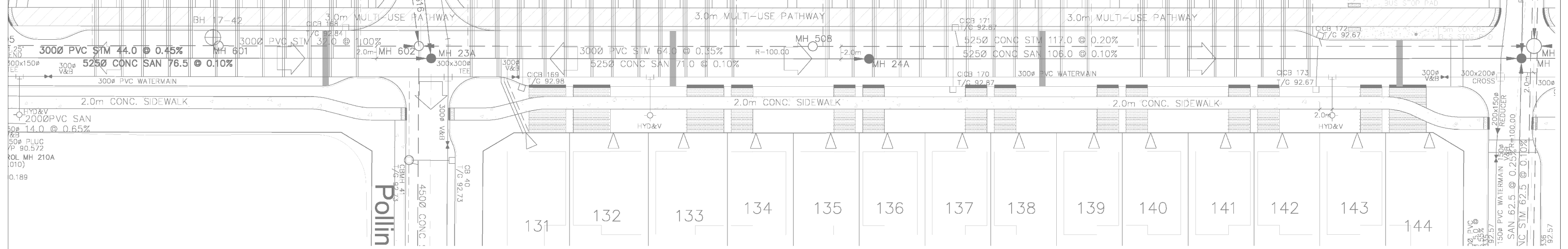

HYD&V
2000 PVC SAN
14.0 @ 0.65%
500 PLUG
P 90.572
POL MH 210A
(10)
0.189

200x1500
REDUCER
SAN 62.5 @ 0.25%
VC STM 62.5 @ 0.10%
300 V&B
300x200
CROSS
2.0m
HYD&V
2.0m

Project: **1398 BCDC – Stormtech 1**



Chamber Model -	DC-780
Units -	Metric
Number of Chambers -	3
Number of End Caps -	2
Voids in the stone (porosity) -	40 %
Base of Stone Elevation -	91.56 m
Amount of Stone Above Chambers -	152 mm
Amount of Stone Below Chambers -	229 mm

Area of System- **14.49195** sq.meters Min. Area - 11.01 sq.meters

- Include Perimeter Stone in Calculations
- Click for Stage Area Data
- Click to Invert Stage Area Data
- [Click Here for Imperial](#)

StormTech DC-780 Cumulative Storage Volumes								
Height of System (mm)	Incremental Single Chamber (cubic meters)	Incremental Single End Cap (cubic meters)	Incremental Chambers (cubic meters)	Incremental End Cap (cubic meters)	Incremental Stone (cubic meters)	Incremental Ch. EC and Stone (cubic meters)	Cumulative System (cubic)	Elevation (meters)
1143	0.000	0.000	0.00	0.00	0.15	0.15	9.07	92.71
1118	0.000	0.000	0.00	0.00	0.15	0.15	8.93	92.68
1092	0.000	0.000	0.00	0.00	0.15	0.15	8.78	92.65
1067	0.000	0.000	0.00	0.00	0.15	0.15	8.63	92.63
1041	0.000	0.000	0.00	0.00	0.15	0.15	8.49	92.60
1016	0.000	0.000	0.00	0.00	0.15	0.15	8.34	92.58
991	0.002	0.000	0.00	0.00	0.15	0.15	8.19	92.55
965	0.005	0.000	0.01	0.00	0.14	0.16	8.04	92.53
940	0.008	0.000	0.02	0.00	0.14	0.16	7.88	92.50
914	0.017	0.000	0.05	0.00	0.13	0.18	7.72	92.48
889	0.023	0.000	0.07	0.00	0.12	0.19	7.54	92.45
864	0.027	0.001	0.08	0.00	0.11	0.20	7.36	92.43
838	0.031	0.001	0.09	0.00	0.11	0.20	7.16	92.40
813	0.034	0.001	0.10	0.00	0.11	0.21	6.96	92.37
787	0.036	0.001	0.11	0.00	0.10	0.21	6.75	92.35
762	0.039	0.002	0.12	0.00	0.10	0.22	6.53	92.32
737	0.041	0.002	0.12	0.00	0.10	0.22	6.31	92.30
711	0.043	0.002	0.13	0.00	0.09	0.23	6.09	92.27
686	0.045	0.002	0.14	0.00	0.09	0.23	5.86	92.25
660	0.047	0.003	0.14	0.01	0.09	0.23	5.63	92.22
635	0.048	0.003	0.15	0.01	0.09	0.24	5.40	92.20
610	0.050	0.003	0.15	0.01	0.09	0.24	5.16	92.17
584	0.051	0.003	0.15	0.01	0.08	0.24	4.92	92.15
559	0.053	0.003	0.16	0.01	0.08	0.25	4.68	92.12
533	0.054	0.003	0.16	0.01	0.08	0.25	4.43	92.10
508	0.055	0.003	0.17	0.01	0.08	0.25	4.18	92.07
483	0.056	0.004	0.17	0.01	0.08	0.25	3.93	92.04
457	0.057	0.004	0.17	0.01	0.08	0.26	3.68	92.02
432	0.058	0.004	0.17	0.01	0.07	0.26	3.42	91.99
406	0.059	0.004	0.18	0.01	0.07	0.26	3.17	91.97
381	0.060	0.004	0.18	0.01	0.07	0.26	2.91	91.94
356	0.061	0.005	0.18	0.01	0.07	0.26	2.65	91.92
330	0.062	0.005	0.18	0.01	0.07	0.26	2.39	91.89
305	0.062	0.005	0.19	0.01	0.07	0.26	2.12	91.87
279	0.063	0.005	0.19	0.01	0.07	0.27	1.86	91.84
254	0.064	0.003	0.19	0.01	0.07	0.27	1.59	91.82
229	0.000	0.000	0.00	0.00	0.15	0.15	1.33	91.79
203	0.000	0.000	0.00	0.00	0.15	0.15	1.18	91.77
178	0.000	0.000	0.00	0.00	0.15	0.15	1.03	91.74
152	0.000	0.000	0.00	0.00	0.15	0.15	0.88	91.71
127	0.000	0.000	0.00	0.00	0.15	0.15	0.74	91.69
102	0.000	0.000	0.00	0.00	0.15	0.15	0.59	91.66
76	0.000	0.000	0.00	0.00	0.15	0.15	0.44	91.64
51	0.000	0.000	0.00	0.00	0.15	0.15	0.29	91.61
25	0.000	0.000	0.00	0.00	0.15	0.15	0.15	91.59

Project: 1398 BCDC – Stormtech 2



Chamber Model -	DC-780
Units -	Metric
Number of Chambers -	2
Number of End Caps -	2
Voids in the stone (porosity) -	40 %
Base of Stone Elevation -	91.37 m
Amount of Stone Above Chambers -	152 mm
Amount of Stone Below Chambers -	229 mm

Area of System- 10.35962 sq.meters Min. Area - 7.87 sq.meters

- Include Perimeter Stone in Calculations
- Click for Stage Area Data
- Click to Invert Stage Area Data
- [Click Here for Imperial](#)

StormTech DC-780 Cumulative Storage Volumes								
Height of System (mm)	Incremental Single Chamber (cubic meters)	Incremental Single End Cap (cubic meters)	Incremental Chambers (cubic meters)	Incremental End Cap (cubic meters)	Incremental Stone (cubic meters)	Incremental Ch. EC and Stone (cubic meters)	Cumulative System (cubic)	Elevation (meters)
1143	0.000	0.000	0.00	0.00	0.11	0.11	6.40	92.52
1118	0.000	0.000	0.00	0.00	0.11	0.11	6.29	92.49
1092	0.000	0.000	0.00	0.00	0.11	0.11	6.19	92.46
1067	0.000	0.000	0.00	0.00	0.11	0.11	6.08	92.44
1041	0.000	0.000	0.00	0.00	0.11	0.11	5.98	92.41
1016	0.000	0.000	0.00	0.00	0.11	0.11	5.87	92.39
991	0.002	0.000	0.00	0.00	0.10	0.11	5.77	92.36
965	0.005	0.000	0.01	0.00	0.10	0.11	5.66	92.34
940	0.008	0.000	0.02	0.00	0.10	0.12	5.55	92.31
914	0.017	0.000	0.03	0.00	0.09	0.13	5.43	92.29
889	0.023	0.000	0.05	0.00	0.09	0.13	5.31	92.26
864	0.027	0.001	0.05	0.00	0.08	0.14	5.17	92.24
838	0.031	0.001	0.06	0.00	0.08	0.14	5.04	92.21
813	0.034	0.001	0.07	0.00	0.08	0.15	4.89	92.18
787	0.036	0.001	0.07	0.00	0.08	0.15	4.75	92.16
762	0.039	0.002	0.08	0.00	0.07	0.15	4.60	92.13
737	0.041	0.002	0.08	0.00	0.07	0.16	4.44	92.11
711	0.043	0.002	0.09	0.00	0.07	0.16	4.29	92.08
686	0.045	0.002	0.09	0.00	0.07	0.16	4.13	92.06
660	0.047	0.003	0.09	0.01	0.07	0.16	3.96	92.03
635	0.048	0.003	0.10	0.01	0.06	0.17	3.80	92.01
610	0.050	0.003	0.10	0.01	0.06	0.17	3.63	91.98
584	0.051	0.003	0.10	0.01	0.06	0.17	3.47	91.96
559	0.053	0.003	0.11	0.01	0.06	0.17	3.29	91.93
533	0.054	0.003	0.11	0.01	0.06	0.17	3.12	91.91
508	0.055	0.003	0.11	0.01	0.06	0.18	2.95	91.88
483	0.056	0.004	0.11	0.01	0.06	0.18	2.77	91.85
457	0.057	0.004	0.11	0.01	0.06	0.18	2.60	91.83
432	0.058	0.004	0.12	0.01	0.06	0.18	2.42	91.80
406	0.059	0.004	0.12	0.01	0.05	0.18	2.24	91.78
381	0.060	0.004	0.12	0.01	0.05	0.18	2.06	91.75
356	0.061	0.005	0.12	0.01	0.05	0.18	1.87	91.73
330	0.062	0.005	0.12	0.01	0.05	0.18	1.69	91.70
305	0.062	0.005	0.12	0.01	0.05	0.19	1.50	91.68
279	0.063	0.005	0.13	0.01	0.05	0.19	1.32	91.65
254	0.064	0.003	0.13	0.01	0.05	0.19	1.13	91.63
229	0.000	0.000	0.00	0.00	0.11	0.11	0.95	91.60
203	0.000	0.000	0.00	0.00	0.11	0.11	0.84	91.58
178	0.000	0.000	0.00	0.00	0.11	0.11	0.74	91.55
152	0.000	0.000	0.00	0.00	0.11	0.11	0.63	91.52
127	0.000	0.000	0.00	0.00	0.11	0.11	0.53	91.50
102	0.000	0.000	0.00	0.00	0.11	0.11	0.42	91.47
76	0.000	0.000	0.00	0.00	0.11	0.11	0.32	91.45
51	0.000	0.000	0.00	0.00	0.11	0.11	0.21	91.42
25	0.000	0.000	0.00	0.00	0.11	0.11	0.11	91.40

Project: 1398 BCDC – Stormtech 3



Chamber Model -	DC-780
Units -	Metric
Number of Chambers -	2
Number of End Caps -	2
Voids in the stone (porosity) -	40 %
Base of Stone Elevation -	91.32 m
Amount of Stone Above Chambers -	152 mm
Amount of Stone Below Chambers -	229 mm

Area of System- 10.35962 sq.meters Min. Area - 7.87 sq.meters

- Include Perimeter Stone in Calculations
- Click for Stage Area Data
- Click to Invert Stage Area Data
- [Click Here for Imperial](#)

StormTech DC-780 Cumulative Storage Volumes								
Height of System (mm)	Incremental Single Chamber (cubic meters)	Incremental Single End Cap (cubic meters)	Incremental Chambers (cubic meters)	Incremental End Cap (cubic meters)	Incremental Stone (cubic meters)	Incremental Ch. EC and Stone (cubic meters)	Cumulative System (cubic)	Elevation (meters)
1143	0.000	0.000	0.00	0.00	0.11	0.11	6.40	92.47
1118	0.000	0.000	0.00	0.00	0.11	0.11	6.29	92.44
1092	0.000	0.000	0.00	0.00	0.11	0.11	6.19	92.41
1067	0.000	0.000	0.00	0.00	0.11	0.11	6.08	92.39
1041	0.000	0.000	0.00	0.00	0.11	0.11	5.98	92.36
1016	0.000	0.000	0.00	0.00	0.11	0.11	5.87	92.34
991	0.002	0.000	0.00	0.00	0.10	0.11	5.77	92.31
965	0.005	0.000	0.01	0.00	0.10	0.11	5.66	92.29
940	0.008	0.000	0.02	0.00	0.10	0.12	5.55	92.26
914	0.017	0.000	0.03	0.00	0.09	0.13	5.43	92.24
889	0.023	0.000	0.05	0.00	0.09	0.13	5.31	92.21
864	0.027	0.001	0.05	0.00	0.08	0.14	5.17	92.19
838	0.031	0.001	0.06	0.00	0.08	0.14	5.04	92.16
813	0.034	0.001	0.07	0.00	0.08	0.15	4.89	92.13
787	0.036	0.001	0.07	0.00	0.08	0.15	4.75	92.11
762	0.039	0.002	0.08	0.00	0.07	0.15	4.60	92.08
737	0.041	0.002	0.08	0.00	0.07	0.16	4.44	92.06
711	0.043	0.002	0.09	0.00	0.07	0.16	4.29	92.03
686	0.045	0.002	0.09	0.00	0.07	0.16	4.13	92.01
660	0.047	0.003	0.09	0.01	0.07	0.16	3.96	91.98
635	0.048	0.003	0.10	0.01	0.06	0.17	3.80	91.96
610	0.050	0.003	0.10	0.01	0.06	0.17	3.63	91.93
584	0.051	0.003	0.10	0.01	0.06	0.17	3.47	91.91
559	0.053	0.003	0.11	0.01	0.06	0.17	3.29	91.88
533	0.054	0.003	0.11	0.01	0.06	0.17	3.12	91.86
508	0.055	0.003	0.11	0.01	0.06	0.18	2.95	91.83
483	0.056	0.004	0.11	0.01	0.06	0.18	2.77	91.80
457	0.057	0.004	0.11	0.01	0.06	0.18	2.60	91.78
432	0.058	0.004	0.12	0.01	0.06	0.18	2.42	91.75
406	0.059	0.004	0.12	0.01	0.05	0.18	2.24	91.73
381	0.060	0.004	0.12	0.01	0.05	0.18	2.06	91.70
356	0.061	0.005	0.12	0.01	0.05	0.18	1.87	91.68
330	0.062	0.005	0.12	0.01	0.05	0.18	1.69	91.65
305	0.062	0.005	0.12	0.01	0.05	0.19	1.50	91.63
279	0.063	0.005	0.13	0.01	0.05	0.19	1.32	91.60
254	0.064	0.003	0.13	0.01	0.05	0.19	1.13	91.58
229	0.000	0.000	0.00	0.00	0.11	0.11	0.95	91.55
203	0.000	0.000	0.00	0.00	0.11	0.11	0.84	91.53
178	0.000	0.000	0.00	0.00	0.11	0.11	0.74	91.50
152	0.000	0.000	0.00	0.00	0.11	0.11	0.63	91.47
127	0.000	0.000	0.00	0.00	0.11	0.11	0.53	91.45
102	0.000	0.000	0.00	0.00	0.11	0.11	0.42	91.42
76	0.000	0.000	0.00	0.00	0.11	0.11	0.32	91.40
51	0.000	0.000	0.00	0.00	0.11	0.11	0.21	91.37
25	0.000	0.000	0.00	0.00	0.11	0.11	0.11	91.35

Project: **1398 BCDC – Stormtech 4**



Chamber Model -	DC-780
Units -	Metric
Number of Chambers -	2
Number of End Caps -	2
Voids in the stone (porosity) -	40 %
Base of Stone Elevation -	91.47 m
Amount of Stone Above Chambers -	152 mm
Amount of Stone Below Chambers -	229 mm

Area of System- **10.35962** sq.meters Min. Area - 7.87 sq.meters

- Include Perimeter Stone in Calculations
- Click for Stage Area Data
- Click to Invert Stage Area Data
- [Click Here for Imperial](#)

StormTech DC-780 Cumulative Storage Volumes								
Height of System (mm)	Incremental Single Chamber (cubic meters)	Incremental Single End Cap (cubic meters)	Incremental Chambers (cubic meters)	Incremental End Cap (cubic meters)	Incremental Stone (cubic meters)	Incremental Ch. EC and Stone (cubic meters)	Cumulative System (cubic)	Elevation (meters)
1143	0.000	0.000	0.00	0.00	0.11	0.11	6.40	92.62
1118	0.000	0.000	0.00	0.00	0.11	0.11	6.29	92.59
1092	0.000	0.000	0.00	0.00	0.11	0.11	6.19	92.56
1067	0.000	0.000	0.00	0.00	0.11	0.11	6.08	92.54
1041	0.000	0.000	0.00	0.00	0.11	0.11	5.98	92.51
1016	0.000	0.000	0.00	0.00	0.11	0.11	5.87	92.49
991	0.002	0.000	0.00	0.00	0.10	0.11	5.77	92.46
965	0.005	0.000	0.01	0.00	0.10	0.11	5.66	92.44
940	0.008	0.000	0.02	0.00	0.10	0.12	5.55	92.41
914	0.017	0.000	0.03	0.00	0.09	0.13	5.43	92.39
889	0.023	0.000	0.05	0.00	0.09	0.13	5.31	92.36
864	0.027	0.001	0.05	0.00	0.08	0.14	5.17	92.34
838	0.031	0.001	0.06	0.00	0.08	0.14	5.04	92.31
813	0.034	0.001	0.07	0.00	0.08	0.15	4.89	92.28
787	0.036	0.001	0.07	0.00	0.08	0.15	4.75	92.26
762	0.039	0.002	0.08	0.00	0.07	0.15	4.60	92.23
737	0.041	0.002	0.08	0.00	0.07	0.16	4.44	92.21
711	0.043	0.002	0.09	0.00	0.07	0.16	4.29	92.18
686	0.045	0.002	0.09	0.00	0.07	0.16	4.13	92.16
660	0.047	0.003	0.09	0.01	0.07	0.16	3.96	92.13
635	0.048	0.003	0.10	0.01	0.06	0.17	3.80	92.11
610	0.050	0.003	0.10	0.01	0.06	0.17	3.63	92.08
584	0.051	0.003	0.10	0.01	0.06	0.17	3.47	92.06
559	0.053	0.003	0.11	0.01	0.06	0.17	3.29	92.03
533	0.054	0.003	0.11	0.01	0.06	0.17	3.12	92.01
508	0.055	0.003	0.11	0.01	0.06	0.18	2.95	91.98
483	0.056	0.004	0.11	0.01	0.06	0.18	2.77	91.95
457	0.057	0.004	0.11	0.01	0.06	0.18	2.60	91.93
432	0.058	0.004	0.12	0.01	0.06	0.18	2.42	91.90
406	0.059	0.004	0.12	0.01	0.05	0.18	2.24	91.88
381	0.060	0.004	0.12	0.01	0.05	0.18	2.06	91.85
356	0.061	0.005	0.12	0.01	0.05	0.18	1.87	91.83
330	0.062	0.005	0.12	0.01	0.05	0.18	1.69	91.80
305	0.062	0.005	0.12	0.01	0.05	0.19	1.50	91.78
279	0.063	0.005	0.13	0.01	0.05	0.19	1.32	91.75
254	0.064	0.003	0.13	0.01	0.05	0.19	1.13	91.73
229	0.000	0.000	0.00	0.00	0.11	0.11	0.95	91.70
203	0.000	0.000	0.00	0.00	0.11	0.11	0.84	91.68
178	0.000	0.000	0.00	0.00	0.11	0.11	0.74	91.65
152	0.000	0.000	0.00	0.00	0.11	0.11	0.63	91.62
127	0.000	0.000	0.00	0.00	0.11	0.11	0.53	91.60
102	0.000	0.000	0.00	0.00	0.11	0.11	0.42	91.57
76	0.000	0.000	0.00	0.00	0.11	0.11	0.32	91.55
51	0.000	0.000	0.00	0.00	0.11	0.11	0.21	91.52
25	0.000	0.000	0.00	0.00	0.11	0.11	0.11	91.50

Project: **1398 BCDC – Stormtech 5**



Chamber Model -	DC-780
Units -	Metric
Number of Chambers -	3
Number of End Caps -	2
Voids in the stone (porosity) -	40 %
Base of Stone Elevation -	91.20 m
Amount of Stone Above Chambers -	152 mm
Amount of Stone Below Chambers -	229 mm

Area of System- **14.49195** sq.meters Min. Area - 11.01 sq.meters

Include Perimeter Stone in Calculations

Click for Stage Area Data

Click to Invert Stage Area Data

[Click Here for Imperial](#)

StormTech DC-780 Cumulative Storage Volumes

Height of System (mm)	Incremental Single Chamber (cubic meters)	Incremental Single End Cap (cubic meters)	Incremental Chambers (cubic meters)	Incremental End Cap (cubic meters)	Incremental Stone (cubic meters)	Incremental Ch. EC and Stone (cubic meters)	Cumulative System (cubic)	Elevation (meters)
1143	0.000	0.000	0.00	0.00	0.15	0.15	9.07	92.35
1118	0.000	0.000	0.00	0.00	0.15	0.15	8.93	92.32
1092	0.000	0.000	0.00	0.00	0.15	0.15	8.78	92.29
1067	0.000	0.000	0.00	0.00	0.15	0.15	8.63	92.27
1041	0.000	0.000	0.00	0.00	0.15	0.15	8.49	92.24
1016	0.000	0.000	0.00	0.00	0.15	0.15	8.34	92.22
991	0.002	0.000	0.00	0.00	0.15	0.15	8.19	92.19
965	0.005	0.000	0.01	0.00	0.14	0.16	8.04	92.17
940	0.008	0.000	0.02	0.00	0.14	0.16	7.88	92.14
914	0.017	0.000	0.05	0.00	0.13	0.18	7.72	92.12
889	0.023	0.000	0.07	0.00	0.12	0.19	7.54	92.09
864	0.027	0.001	0.08	0.00	0.11	0.20	7.36	92.07
838	0.031	0.001	0.09	0.00	0.11	0.20	7.16	92.04
813	0.034	0.001	0.10	0.00	0.11	0.21	6.96	92.01
787	0.036	0.001	0.11	0.00	0.10	0.21	6.75	91.99
762	0.039	0.002	0.12	0.00	0.10	0.22	6.53	91.96
737	0.041	0.002	0.12	0.00	0.10	0.22	6.31	91.94
711	0.043	0.002	0.13	0.00	0.09	0.23	6.09	91.91
686	0.045	0.002	0.14	0.00	0.09	0.23	5.86	91.89
660	0.047	0.003	0.14	0.01	0.09	0.23	5.63	91.86
635	0.048	0.003	0.15	0.01	0.09	0.24	5.40	91.84
610	0.050	0.003	0.15	0.01	0.09	0.24	5.16	91.81
584	0.051	0.003	0.15	0.01	0.08	0.24	4.92	91.79
559	0.053	0.003	0.16	0.01	0.08	0.25	4.68	91.76
533	0.054	0.003	0.16	0.01	0.08	0.25	4.43	91.74
508	0.055	0.003	0.17	0.01	0.08	0.25	4.18	91.71
483	0.056	0.004	0.17	0.01	0.08	0.25	3.93	91.68
457	0.057	0.004	0.17	0.01	0.08	0.26	3.68	91.66
432	0.058	0.004	0.17	0.01	0.07	0.26	3.42	91.63
406	0.059	0.004	0.18	0.01	0.07	0.26	3.17	91.61
381	0.060	0.004	0.18	0.01	0.07	0.26	2.91	91.58
356	0.061	0.005	0.18	0.01	0.07	0.26	2.65	91.56
330	0.062	0.005	0.18	0.01	0.07	0.26	2.39	91.53
305	0.062	0.005	0.19	0.01	0.07	0.26	2.12	91.51
279	0.063	0.005	0.19	0.01	0.07	0.27	1.86	91.48
254	0.064	0.003	0.19	0.01	0.07	0.27	1.59	91.46
229	0.000	0.000	0.00	0.00	0.15	0.15	1.33	91.43
203	0.000	0.000	0.00	0.00	0.15	0.15	1.18	91.41
178	0.000	0.000	0.00	0.00	0.15	0.15	1.03	91.38
152	0.000	0.000	0.00	0.00	0.15	0.15	0.88	91.35
127	0.000	0.000	0.00	0.00	0.15	0.15	0.74	91.33
102	0.000	0.000	0.00	0.00	0.15	0.15	0.59	91.30
76	0.000	0.000	0.00	0.00	0.15	0.15	0.44	91.28
51	0.000	0.000	0.00	0.00	0.15	0.15	0.29	91.25
25	0.000	0.000	0.00	0.00	0.15	0.15	0.15	91.23

Project: **1398 BCDC – Stormtech 6**



Chamber Model -	DC-780
Units -	Metric
Number of Chambers -	3
Number of End Caps -	2
Voids in the stone (porosity) -	40 %
Base of Stone Elevation -	91.34 m
Amount of Stone Above Chambers -	152 mm
Amount of Stone Below Chambers -	229 mm

Area of System- **14.49195** sq.meters Min. Area - 11.01 sq.meters

- Include Perimeter Stone in Calculations
- Click for Stage Area Data
- Click to Invert Stage Area Data
- [Click Here for Imperial](#)

StormTech DC-780 Cumulative Storage Volumes								
Height of System (mm)	Incremental Single Chamber (cubic meters)	Incremental Single End Cap (cubic meters)	Incremental Chambers (cubic meters)	Incremental End Cap (cubic meters)	Incremental Stone (cubic meters)	Incremental Ch. EC and Stone (cubic meters)	Cumulative System (cubic)	Elevation (meters)
1143	0.000	0.000	0.00	0.00	0.15	0.15	9.07	92.49
1118	0.000	0.000	0.00	0.00	0.15	0.15	8.93	92.46
1092	0.000	0.000	0.00	0.00	0.15	0.15	8.78	92.43
1067	0.000	0.000	0.00	0.00	0.15	0.15	8.63	92.41
1041	0.000	0.000	0.00	0.00	0.15	0.15	8.49	92.38
1016	0.000	0.000	0.00	0.00	0.15	0.15	8.34	92.36
991	0.002	0.000	0.00	0.00	0.15	0.15	8.19	92.33
965	0.005	0.000	0.01	0.00	0.14	0.16	8.04	92.31
940	0.008	0.000	0.02	0.00	0.14	0.16	7.88	92.28
914	0.017	0.000	0.05	0.00	0.13	0.18	7.72	92.26
889	0.023	0.000	0.07	0.00	0.12	0.19	7.54	92.23
864	0.027	0.001	0.08	0.00	0.11	0.20	7.36	92.21
838	0.031	0.001	0.09	0.00	0.11	0.20	7.16	92.18
813	0.034	0.001	0.10	0.00	0.11	0.21	6.96	92.15
787	0.036	0.001	0.11	0.00	0.10	0.21	6.75	92.13
762	0.039	0.002	0.12	0.00	0.10	0.22	6.53	92.10
737	0.041	0.002	0.12	0.00	0.10	0.22	6.31	92.08
711	0.043	0.002	0.13	0.00	0.09	0.23	6.09	92.05
686	0.045	0.002	0.14	0.00	0.09	0.23	5.86	92.03
660	0.047	0.003	0.14	0.01	0.09	0.23	5.63	92.00
635	0.048	0.003	0.15	0.01	0.09	0.24	5.40	91.98
610	0.050	0.003	0.15	0.01	0.09	0.24	5.16	91.95
584	0.051	0.003	0.15	0.01	0.08	0.24	4.92	91.93
559	0.053	0.003	0.16	0.01	0.08	0.25	4.68	91.90
533	0.054	0.003	0.16	0.01	0.08	0.25	4.43	91.88
508	0.055	0.003	0.17	0.01	0.08	0.25	4.18	91.85
483	0.056	0.004	0.17	0.01	0.08	0.25	3.93	91.82
457	0.057	0.004	0.17	0.01	0.08	0.26	3.68	91.80
432	0.058	0.004	0.17	0.01	0.07	0.26	3.42	91.77
406	0.059	0.004	0.18	0.01	0.07	0.26	3.17	91.75
381	0.060	0.004	0.18	0.01	0.07	0.26	2.91	91.72
356	0.061	0.005	0.18	0.01	0.07	0.26	2.65	91.70
330	0.062	0.005	0.18	0.01	0.07	0.26	2.39	91.67
305	0.062	0.005	0.19	0.01	0.07	0.26	2.12	91.65
279	0.063	0.005	0.19	0.01	0.07	0.27	1.86	91.62
254	0.064	0.003	0.19	0.01	0.07	0.27	1.59	91.60
229	0.000	0.000	0.00	0.00	0.15	0.15	1.33	91.57
203	0.000	0.000	0.00	0.00	0.15	0.15	1.18	91.55
178	0.000	0.000	0.00	0.00	0.15	0.15	1.03	91.52
152	0.000	0.000	0.00	0.00	0.15	0.15	0.88	91.49
127	0.000	0.000	0.00	0.00	0.15	0.15	0.74	91.47
102	0.000	0.000	0.00	0.00	0.15	0.15	0.59	91.44
76	0.000	0.000	0.00	0.00	0.15	0.15	0.44	91.42
51	0.000	0.000	0.00	0.00	0.15	0.15	0.29	91.39
25	0.000	0.000	0.00	0.00	0.15	0.15	0.15	91.37

Project: 1398 BCDC – Stormtech 7



Chamber Model -	DC-780
Units -	Metric
Number of Chambers -	3
Number of End Caps -	2
Voids in the stone (porosity) -	40 %
Base of Stone Elevation -	91.29 m
Amount of Stone Above Chambers -	152 mm
Amount of Stone Below Chambers -	229 mm

Area of System- 14.49195 sq.meters Min. Area - 11.01 sq.meters

- Include Perimeter Stone in Calculations
- Click for Stage Area Data
- Click to Invert Stage Area Data
- [Click Here for Imperial](#)

StormTech DC-780 Cumulative Storage Volumes

Height of System (mm)	Incremental Single Chamber (cubic meters)	Incremental Single End Cap (cubic meters)	Incremental Chambers (cubic meters)	Incremental End Cap (cubic meters)	Incremental Stone (cubic meters)	Incremental Ch. EC and Stone (cubic meters)	Cumulative System (cubic)	Elevation (meters)
1143	0.000	0.000	0.00	0.00	0.15	0.15	9.07	92.44
1118	0.000	0.000	0.00	0.00	0.15	0.15	8.93	92.41
1092	0.000	0.000	0.00	0.00	0.15	0.15	8.78	92.38
1067	0.000	0.000	0.00	0.00	0.15	0.15	8.63	92.36
1041	0.000	0.000	0.00	0.00	0.15	0.15	8.49	92.33
1016	0.000	0.000	0.00	0.00	0.15	0.15	8.34	92.31
991	0.002	0.000	0.00	0.00	0.15	0.15	8.19	92.28
965	0.005	0.000	0.01	0.00	0.14	0.16	8.04	92.26
940	0.008	0.000	0.02	0.00	0.14	0.16	7.88	92.23
914	0.017	0.000	0.05	0.00	0.13	0.18	7.72	92.21
889	0.023	0.000	0.07	0.00	0.12	0.19	7.54	92.18
864	0.027	0.001	0.08	0.00	0.11	0.20	7.36	92.16
838	0.031	0.001	0.09	0.00	0.11	0.20	7.16	92.13
813	0.034	0.001	0.10	0.00	0.11	0.21	6.96	92.10
787	0.036	0.001	0.11	0.00	0.10	0.21	6.75	92.08
762	0.039	0.002	0.12	0.00	0.10	0.22	6.53	92.05
737	0.041	0.002	0.12	0.00	0.10	0.22	6.31	92.03
711	0.043	0.002	0.13	0.00	0.09	0.23	6.09	92.00
686	0.045	0.002	0.14	0.00	0.09	0.23	5.86	91.98
660	0.047	0.003	0.14	0.01	0.09	0.23	5.63	91.95
635	0.048	0.003	0.15	0.01	0.09	0.24	5.40	91.93
610	0.050	0.003	0.15	0.01	0.09	0.24	5.16	91.90
584	0.051	0.003	0.15	0.01	0.08	0.24	4.92	91.88
559	0.053	0.003	0.16	0.01	0.08	0.25	4.68	91.85
533	0.054	0.003	0.16	0.01	0.08	0.25	4.43	91.83
508	0.055	0.003	0.17	0.01	0.08	0.25	4.18	91.80
483	0.056	0.004	0.17	0.01	0.08	0.25	3.93	91.77
457	0.057	0.004	0.17	0.01	0.08	0.26	3.68	91.75
432	0.058	0.004	0.17	0.01	0.07	0.26	3.42	91.72
406	0.059	0.004	0.18	0.01	0.07	0.26	3.17	91.70
381	0.060	0.004	0.18	0.01	0.07	0.26	2.91	91.67
356	0.061	0.005	0.18	0.01	0.07	0.26	2.65	91.65
330	0.062	0.005	0.18	0.01	0.07	0.26	2.39	91.62
305	0.062	0.005	0.19	0.01	0.07	0.26	2.12	91.60
279	0.063	0.005	0.19	0.01	0.07	0.27	1.86	91.57
254	0.064	0.003	0.19	0.01	0.07	0.27	1.59	91.55
229	0.000	0.000	0.00	0.00	0.15	0.15	1.33	91.52
203	0.000	0.000	0.00	0.00	0.15	0.15	1.18	91.50
178	0.000	0.000	0.00	0.00	0.15	0.15	1.03	91.47
152	0.000	0.000	0.00	0.00	0.15	0.15	0.88	91.44
127	0.000	0.000	0.00	0.00	0.15	0.15	0.74	91.42
102	0.000	0.000	0.00	0.00	0.15	0.15	0.59	91.39
76	0.000	0.000	0.00	0.00	0.15	0.15	0.44	91.37
51	0.000	0.000	0.00	0.00	0.15	0.15	0.29	91.34
25	0.000	0.000	0.00	0.00	0.15	0.15	0.15	91.32

PROJECT NO.: 24-1398
DATE: August 2024
PREPARED BY: Andrea Lizarraga
REVIEWED BY: Michelle Henry, P.Eng.
SUBJECT: Water Quality Control Strategy and HGL Analysis for the Barrhaven Conservancy East Site Plan
ATTACHMENTS: Attachment 1 – Oil Grit Separator
Attachment 2 – Storm Sewer Design Sheet
Attachment 3 – Hydraulic Gradeline Analysis

The proposed Site Plan is approximately 1.76 hectares and is contained within the Barrhaven Conservancy East Development. Located in Barrhaven, Ontario, north of Conservancy Drive, east and south of Les Emmerson Drive and west of Mineral Street. There is no quantity control required within the development, however 80% TSS removal is required for quality control, and an HGL assessment has been considered below.

Quality Control

Per the MOE SWM Planning and Design Manual (2003), 80% TSS removal is to be provided for the site plan. This will be achieved through a treatment train approach consisting of deep sumps, CB Shield, infiltration trenches and downstream oil and grit separators (OGS).

Throughout the site, there are infiltration trenches proposed with varying sizes. Each trench is equipped with a 250 mm perforated sub-drain pipe through the length of the trench. All runoff internal to the site is directed to infiltration trenches. Areas on the boundary of the site drain directly to external subdivision roads. These areas will be treated by infiltration trenches within the wider subdivision. Each infiltration trench has been sized to provide 70% TSS removal as per table 3.2 in the MOE SWMP (2003). This was achieved by ensuring that 30m³/ha of volume is provided in each infiltration trench.

Pre-treatment for the infiltration trenches will be provided by deep sumps and CB Shields, which will be installed at all catch basins within the site plan. Deep sumps can provide 25% TSS removal and CB Shields can provide 25% to 64% removal efficiency depending on flow rates. For consistency with other work completed in this area, CB Shields in this site plan will be assumed to have 27% TSS removal.

At the downstream end of the overall Barrhaven Conservancy East Development, it is proposed to include OGS units prior to discharging to Jock River. Per standard practice each OGS is assumed to provide 50% TSS removal. Downstream OGS sizing can be found in Attachment 1.

This treatment train is designed to achieve more than the required 80% Total Suspended Solids (TSS) removal. The total TSS Removal for the site is calculated as follows:

Total TSS Removal (%) =

$$= 1 - [(1 - \%TSS\ Removal\ Method\ 1) \times (1 - \%TSS\ Removal\ Method\ 2) \times (1 - \%TSS\ Removal\ Method\ 3) \times (1 - \%TSS\ Removal\ Method\ 4)]$$

	Name	Removal %
TSS Removal Method 1	Deep sump	25% ¹
TSS Removal Method 2	CB Shield	27% ²
TSS Removal Method 3	Infiltration Trenches	70% ³
TSS Removal Method 4	OGS	50%
Total TSS Removal %	=	91.8%

Based on the analysis, the proposed LID treatment train strategy achieves a total TSS removal rate of 91.8%, exceeding the required 80% threshold. Therefore, this memo demonstrates that the strategy meets the established water quality targets.

References:

¹ Massachusetts Department of Environmental Protection. Structural BMP Specifications for the Massachusetts Stormwater Handbook, Volume 2 Chapter 2. & Sabourin, J. F. (2021). P1474(05)- 20: Quality Control Alternatives - Summary of Technologies/ Methods. JFSA.

² Sabourin, J. F. (2021). P1474(05)-20: Quality Control Alternatives - Summary of Technologies/ Methods. JFSA.

³ Ontario MOE. Stormwater Management Planning and Design Manual. 2019. Table 3.2.

Hydraulic Gradeline Analysis

A hydraulic gradeline (HGL) analysis was completed through the site plan to ensure safe conveyance of the major and minor stormwater events. A PCSWMM model was used as it provides both hydrologic and hydraulic modeling components. Through PCSWMM, several components were modeled including the catchments, CBs, CB leads, storm sewers and overland flow routes through the streets. The storm sewers were sized to convey the 2-year design storm using the rational method as shown in Attachment 2. Infiltration trenches were intentionally omitted from the HGL modeling as it is only intended for quality control components.

The 100-year HGL was modeled with the City of Ottawa 3-hour Chicago design storm. Boundary conditions at Conservancy Drive and Mineral Street were assumed to be 0.5m below the downstream rim elevations for conservatism. As the overall subdivision design advances, the boundary conditions will be revised as necessary.

Through the modeling, it was found that the 100-year HGL was on average 0.27m below the MH rim elevations. Complete results can be found in Attachment 3. This demonstrates that the storm sewers are sufficiently sized to ensure no surcharging to the surface during major storm events. All units are proposed to have sump pumps, and therefore no further HGL freeboard is required.



Michelle Henry, P.Eng.



Attachment 1

Oil Grit Separator



**CDS ESTIMATED NET ANNUAL SOLIDS LOAD REDUCTION
BASED ON THE RATIONAL RAINFALL METHOD
BASED ON A FINE PARTICLE SIZE DISTRIBUTION**



Project Name: 891 Conservancy East	Engineer: DSEL
Location: Ottawa, ON	Contact: Peter Mott
OGS #: 5	Report Date: 29-Aug-24
Area 8.55 ha	Rainfall Station # 215
Weighted C 0.68	Particle Size Distribution FINE
CDS Model 5640 (OFFLINE)	CDS Treatment Capacity 255 l/s

<u>Rainfall Intensity¹</u> <u>(mm/hr)</u>	<u>Percent Rainfall Volume¹</u>	<u>Cumulative Rainfall Volume</u>	<u>Total Flowrate (l/s)</u>	<u>Treated Flowrate (l/s)</u>	<u>Operating Rate (%)</u>	<u>Removal Efficiency (%)</u>	<u>Incremental Removal (%)</u>
1.0	10.6%	19.8%	16.2	16.2	6.3	97.0	10.3
1.5	9.9%	29.7%	24.2	24.2	9.5	96.1	9.5
2.0	8.4%	38.1%	32.3	32.3	12.7	95.2	8.0
2.5	7.7%	45.8%	40.4	40.4	15.9	94.3	7.3
3.0	5.9%	51.7%	48.5	48.5	19.0	93.4	5.5
3.5	4.4%	56.1%	56.6	56.6	22.2	92.5	4.0
4.0	4.7%	60.7%	64.7	64.7	25.4	91.6	4.3
4.5	3.3%	64.0%	72.7	72.7	28.5	90.7	3.0
5.0	3.0%	67.1%	80.8	80.8	31.7	89.8	2.7
6.0	5.4%	72.4%	97.0	97.0	38.0	88.0	4.7
7.0	4.4%	76.8%	113.1	113.1	44.4	86.1	3.7
8.0	3.5%	80.3%	129.3	129.3	50.7	84.3	3.0
9.0	2.8%	83.2%	145.5	145.5	57.1	82.5	2.3
10.0	2.2%	85.3%	161.6	161.6	63.4	80.7	1.8
15.0	7.0%	92.3%	242.4	242.4	95.1	71.6	5.0
20.0	4.5%	96.9%	323.3	254.9	100.0	55.3	2.5
25.0	1.4%	98.3%	404.1	254.9	100.0	44.3	0.6
30.0	0.7%	99.0%	484.9	254.9	100.0	36.9	0.2
35.0	0.5%	99.5%	565.7	254.9	100.0	31.6	0.1
40.0	0.5%	100.0%	646.5	254.9	100.0	27.7	0.2
							87.9

Removal Efficiency Adjustment² = 6.5%
Predicted Net Annual Load Removal Efficiency = 81.4%
Predicted Annual Rainfall Treated = 97.6%

1 - Based on 42 years of hourly rainfall data from Canadian Station 6105976, Ottawa ON
 2 - Reduction due to use of 60-minute data for a site that has a time of concentration less than 30-minutes.
 3 - CDS Efficiency based on testing conducted at the University of Central Florida
 4 - CDS design flowrate and scaling based on standard manufacturer model & product specifications



**CDS ESTIMATED NET ANNUAL SOLIDS LOAD REDUCTION
BASED ON THE RATIONAL RAINFALL METHOD
BASED ON A FINE PARTICLE SIZE DISTRIBUTION**



Project Name: 891 Conservancy East	Engineer: DSEL
Location: Ottawa, ON	Contact: Peter Mott
OGS #: 6	Report Date: 29-Aug-24
Area 5.94 ha	Rainfall Station # 215
Weighted C 0.55	Particle Size Distribution FINE
CDS Model 4030 (OFFLINE)	CDS Treatment Capacity 127 l/s

<u>Rainfall Intensity¹</u> <u>(mm/hr)</u>	<u>Percent Rainfall Volume¹</u>	<u>Cumulative Rainfall Volume</u>	<u>Total Flowrate (l/s)</u>	<u>Treated Flowrate (l/s)</u>	<u>Operating Rate (%)</u>	<u>Removal Efficiency (%)</u>	<u>Incremental Removal (%)</u>
1.0	10.6%	19.8%	9.1	9.1	7.1	96.8	10.3
1.5	9.9%	29.7%	13.6	13.6	10.7	95.8	9.5
2.0	8.4%	38.1%	18.2	18.2	14.3	94.8	7.9
2.5	7.7%	45.8%	22.7	22.7	17.8	93.8	7.2
3.0	5.9%	51.7%	27.2	27.2	21.4	92.7	5.5
3.5	4.4%	56.1%	31.8	31.8	24.9	91.7	4.0
4.0	4.7%	60.7%	36.3	36.3	28.5	90.7	4.2
4.5	3.3%	64.0%	40.9	40.9	32.1	89.7	3.0
5.0	3.0%	67.1%	45.4	45.4	35.6	88.6	2.7
6.0	5.4%	72.4%	54.5	54.5	42.8	86.6	4.7
7.0	4.4%	76.8%	63.6	63.6	49.9	84.6	3.7
8.0	3.5%	80.3%	72.7	72.7	57.0	82.5	2.9
9.0	2.8%	83.2%	81.7	81.7	64.1	80.5	2.3
10.0	2.2%	85.3%	90.8	90.8	71.3	78.4	1.7
15.0	7.0%	92.3%	136.2	127.4	100.0	65.7	4.6
20.0	4.5%	96.9%	181.6	127.4	100.0	49.2	2.2
25.0	1.4%	98.3%	227.1	127.4	100.0	39.4	0.6
30.0	0.7%	99.0%	272.5	127.4	100.0	32.8	0.2
35.0	0.5%	99.5%	317.9	127.4	100.0	28.1	0.1
40.0	0.5%	100.0%	363.3	127.4	100.0	24.6	0.1
							86.4

Removal Efficiency Adjustment² = 6.5%
Predicted Net Annual Load Removal Efficiency = 80%
Predicted Annual Rainfall Treated = 97%

1 - Based on 42 years of hourly rainfall data from Canadian Station 6105976, Ottawa ON
 2 - Reduction due to use of 60-minute data for a site that has a time of concentration less than 30-minutes.
 3 - CDS Efficiency based on testing conducted at the University of Central Florida
 4 - CDS design flowrate and scaling based on standard manufacturer model & product specifications



**CDS ESTIMATED NET ANNUAL SOLIDS LOAD REDUCTION
BASED ON THE RATIONAL RAINFALL METHOD
BASED ON A FINE PARTICLE SIZE DISTRIBUTION**



Project Name: 891 Conservancy East	Engineer: DSEL
Location: Ottawa, ON	Contact: Peter Mott
OGS #: 7	Report Date: 29-Aug-24
Area 4.83 ha	Rainfall Station # 215
Weighted C 0.75	Particle Size Distribution FINE
CDS Model 4040 (OFFLINE)	CDS Treatment Capacity 170 l/s

<u>Rainfall Intensity¹</u> <u>(mm/hr)</u>	<u>Percent Rainfall Volume¹</u>	<u>Cumulative Rainfall Volume</u>	<u>Total Flowrate (l/s)</u>	<u>Treated Flowrate (l/s)</u>	<u>Operating Rate (%)</u>	<u>Removal Efficiency (%)</u>	<u>Incremental Removal (%)</u>
1.0	10.6%	19.8%	10.1	10.1	5.9	97.2	10.3
1.5	9.9%	29.7%	15.1	15.1	8.9	96.3	9.5
2.0	8.4%	38.1%	20.1	20.1	11.9	95.5	8.0
2.5	7.7%	45.8%	25.2	25.2	14.8	94.6	7.3
3.0	5.9%	51.7%	30.2	30.2	17.8	93.8	5.6
3.5	4.4%	56.1%	35.2	35.2	20.7	92.9	4.0
4.0	4.7%	60.7%	40.3	40.3	23.7	92.1	4.3
4.5	3.3%	64.0%	45.3	45.3	26.7	91.2	3.0
5.0	3.0%	67.1%	50.4	50.4	29.6	90.4	2.7
6.0	5.4%	72.4%	60.4	60.4	35.6	88.7	4.8
7.0	4.4%	76.8%	70.5	70.5	41.5	87.0	3.8
8.0	3.5%	80.3%	80.6	80.6	47.4	85.3	3.0
9.0	2.8%	83.2%	90.6	90.6	53.3	83.6	2.4
10.0	2.2%	85.3%	100.7	100.7	59.3	81.9	1.8
15.0	7.0%	92.3%	151.1	151.1	88.9	73.4	5.1
20.0	4.5%	96.9%	201.4	169.9	100.0	59.2	2.7
25.0	1.4%	98.3%	251.8	169.9	100.0	47.4	0.7
30.0	0.7%	99.0%	302.1	169.9	100.0	39.5	0.3
35.0	0.5%	99.5%	352.5	169.9	100.0	33.8	0.2
40.0	0.5%	100.0%	402.8	169.9	100.0	29.6	0.2
							88.6

Removal Efficiency Adjustment² = 6.5%
Predicted Net Annual Load Removal Efficiency = 82.1%
Predicted Annual Rainfall Treated = 98.0%

1 - Based on 42 years of hourly rainfall data from Canadian Station 6105976, Ottawa ON
 2 - Reduction due to use of 60-minute data for a site that has a time of concentration less than 30-minutes.
 3 - CDS Efficiency based on testing conducted at the University of Central Florida
 4 - CDS design flowrate and scaling based on standard manufacturer model & product specifications



Attachment 2

Storm Sewer Design Sheet

STORM SEWER CALCULATION SHEET (RATIONAL METHOD)

Local Roads Return Frequency = 2 years
 Collector Roads Return Frequency = 5 years
 Arterial Roads Return Frequency = 10 years



Manning 0.013

LOCATION			AREA (Ha)																FLOW					SEWER DATA										
			2 YEAR				5 YEAR				10 YEAR				100 YEAR				Time of	Intensity	Intensity	Intensity	Intensity	Peak Flow	DIA. (mm)	DIA. (mm)	TYPE	SLOPE	LENGTH	CAPACITY	VELOCITY	TIME OF	RATIO	
Location	From Node	To Node	AREA (Ha)	R	Indiv. 2.78 AC	Accum. 2.78 AC	AREA (Ha)	R	Indiv. 2.78 AC	Accum. 2.78 AC	AREA (Ha)	R	Indiv. 2.78 AC	Accum. 2.78 AC	AREA (Ha)	R	Indiv. 2.78 AC	Accum. 2.78 AC	Conc. (min)	2 Year (mm/h)	5 Year (mm/h)	10 Year (mm/h)	100 Year (mm/h)	Q (l/s)	(actual)	(nominal)	(%)	(m)	(l/s)	(m/s)	LOW (min)	Q/Q full		
LANE 2			Contribution From LANE 1, Pipe 613 - 615			0.54				0.00	0.00			0.00	0.00			0.00	0.00	11.25														
	615	616	0.39	0.75	0.81	1.35			0.00	0.00			0.00	0.00			0.00	0.00	11.25	72.33	98.04	114.90	167.92	98	450	450	CONC	0.20	42.0	127.5033	0.8017	0.8732	0.766	
	616	602			0.00	1.35			0.00	0.00			0.00	0.00			0.00	0.00	12.12	69.53	94.19	110.36	161.26	94	450	450	CONC	0.20	12.0	127.5033	0.8017	0.2495	0.737	
LANE 1			To LANE 2, Pipe 615 - 616			0.54				0.00	0.00			0.00	0.00			0.00	0.00	10.00	76.81	104.19	122.14	178.56	41	300	300	PVC	0.35	60.5	57.2089	0.8093	1.2459	0.722
	530	531	0.63	0.80	1.41	1.41			0.00	0.00			0.00	0.00			0.00	0.00	10.00	76.81	104.19	122.14	178.56	108	450	450	CONC	0.20	78.5	127.5033	0.8017	1.6320	0.849	
	531	532			0.00	1.41			0.00	0.00			0.00	0.00			0.00	0.00	11.63	71.06	96.30	112.84	164.90	100	450	450	CONC	0.20	13.0	127.5033	0.8017	0.2703	0.786	
	532	507			0.00	1.41			0.00	0.00			0.00	0.00			0.00	0.00	11.90	70.20	95.12	111.45	162.86	99	450	450	CONC	0.20	12.5	127.5033	0.8017	0.2599	0.776	

Definitions:
 Q = 2.78 AIR, where
 Q = Peak Flow in Litres per second (L/s)
 A = Areas in hectares (ha)
 I = Rainfall Intensity (mm/h)
 R = Runoff Coefficient

Notes:
 1) Ottawa Rainfall-Intensity Curve
 2) Min. Velocity = 0.80 m/s

Designed: M.S.	PROJECT: 1398 - BCDC EAST STACKED CONDO SITE PLAN		
Checked: X.W.	LOCATION: City of Ottawa		
Dwg. Reference: 12	File Ref:	Date: 29 Aug 2024	Sheet No. SHEET 1 OF 1



Attachment 3

Hydraulic Gradeline Analysis

Project Name: Barrhaven Site Plan
Project No.: 1398
Author: MLH
Date: 30-Aug-24

100-Year Chicago 3hr Storm HGL Results

Name	Invert Elev. (m)	Rim Elev. (m)	Max. HGL (m)	Freeboard (m)
MH-613	91.23	93.33	93.01	0.32
MH-615	90.87	93.05	92.93	0.12
MH-616	90.76	92.98	92.77	0.21
MH-531	90.65	92.99	92.76	0.23
MH-530	90.84	93.30	92.96	0.34
MH-532	90.59	93.12	92.71	0.41