

RVCA REGULATORY LIMIT

CAIVAN BCDC EAST PHASE 4

CAIVAN
COMMUNITIES

NAK 
design strategies

LIST OF DRAWINGS:

- L01 - LANDSCAPE PLAN
- L02 - LANDSCAPE PLAN
- L03 - LANDSCAPE DETAILS
- L04 - LANDSCAPE DETAILS

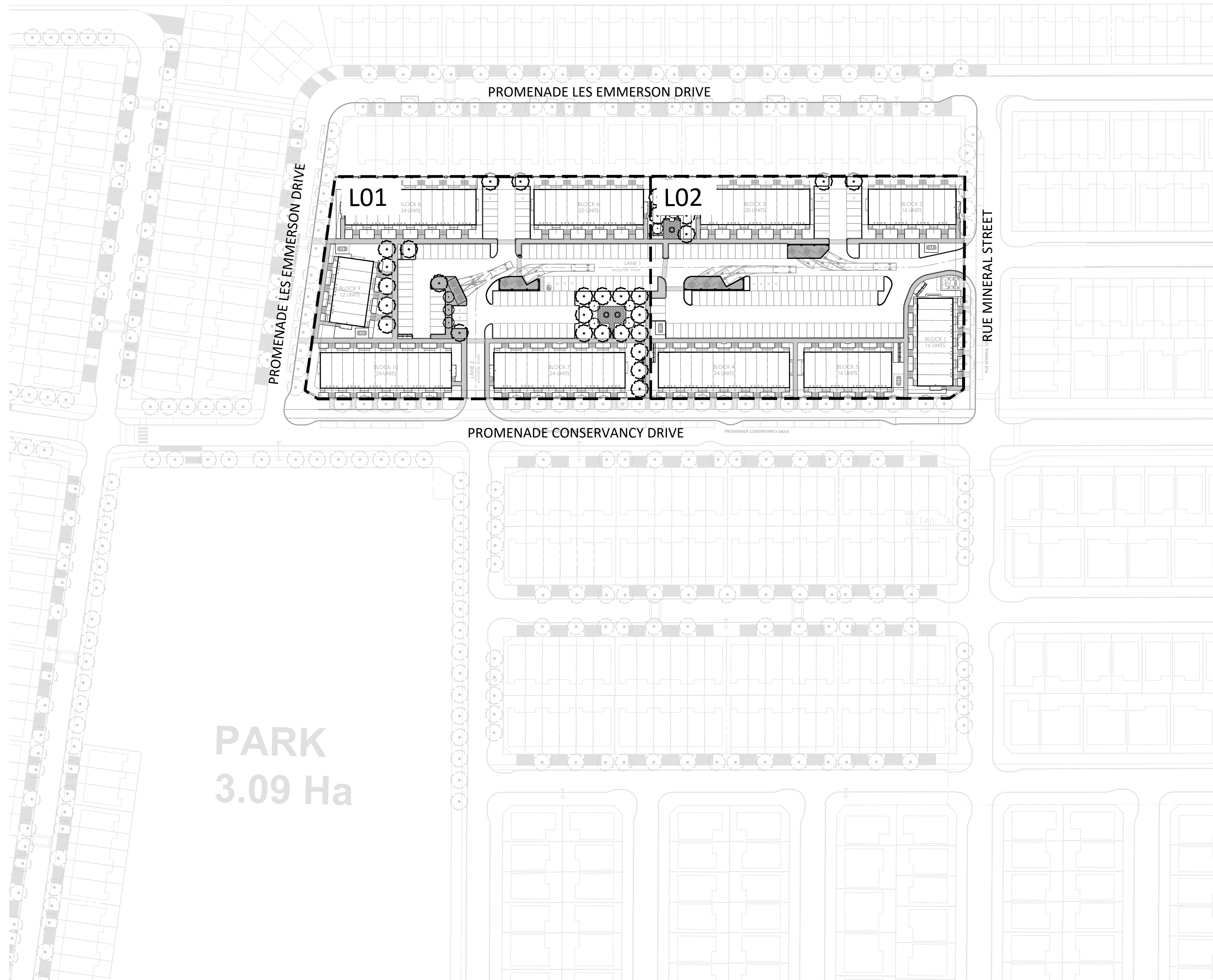

PARK
3.09 Ha

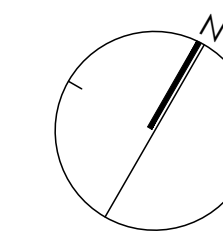

KEYMAP
NTS

KEY	BOTANICAL NAME	COMMON NAME	QUANTITY	SIZE	REMARKS	NATIVE
DECIDUOUS TREES - MEDIUM (8-14M HEIGHT)						
AG	AESCULUS GLABRA	OHIO BUCKEYE	6	50mm	B&B	Y
BL	BETULA LENTA	CHERRY BIRCH	6	50mm	B&B	Y
CC	CARPINUS CAROLINIANA	BLUE BEECH	5	50mm	B&B	Y
CK	CLADRASTIC KENTUCKEA	YELLOW-WOOD	-	50mm	B&B	Y
GT	GLEDITSIA TRIACANTHOS	HONEY LOCUST	7	50mm	B&B	Y
OV	OSTRYA VIRGINIANA	IRONWOOD	3	50mm	B&B	Y
PP	PRUNUS PENSYLVANICA	PIN CHERRY	-	50mm	B&B	Y

QP	QUERCUA PRINUS	CHESTNUT OAK	3	50mm	B&B	Y
DECIDUOUS TREES - SMALL (6-8M HEIGHT)						
AC	AMELANCHIER CANADENSIS	SERVICEBERRY	5	50mm	B&B	Y
CE	CERCIS CANADENSIS	EASTERN REDBUD	4	50mm	B&B	Y
MA	MAACKIA AMURENSIS	AMUR MAACKIA	2	50mm	B&B	Y
MS	MALUS SPP.	CRAB APPLE	-	50mm	B&B	Y
MR	MORUS RUBRA	RED MULBERRY	-	50mm	B&B	Y
CONIFEROUS SHRUBS						
Js	JUNIPERUS SCOPULORUM 'WICHITA BLUE'	WITCHITA BLUE JUNIPER	-	3 GAL	POT	Y
Tc	TAXUS CANADENSIS	CANADIAN YEW	-	3 GAL	POT	Y

DECIDUOUS SHRUBS						
Am	ARONIA MELANOCARPA	BLACK CHOKEBERRY	-	3 GAL	POT	Y
Sa	SYMPHORICARPOS ALBUS	SNOWBERRY	-	3 GAL	POT	Y
Po	PHYSCARPUS OPULIFOLIUS 'DIABOLO'	'DIABOLO' NINEBARK	-	3 GAL	POT	Y
ORNAMENTAL GRASSES						
cl	CHASMANTHIUM LATIFOLIUM	NORTHERN SEA OATS	-	7 GAL	POT	Y
dc	DESCHAMPSIA CESPITOSA	TUFTED HAIR GRASS	-	7 GAL	POT	Y
bg	BOUTELOUA GRACILIS	BLUE GRAMA	-	7 GAL	POT	Y
sh	SPOROBOLUS HETEROLEPSIS	PRARIE DROPSEED	-	7 GAL	POT	Y
ss	SCHIZACHYRIUM SCOPARIUM	LITTLE BLUESTEM	-	7 GAL	POT	Y

GENERAL NOTES:

- ALL PLANT MATERIAL SHALL BE NURSERY GROWN STOCK UNLESS OTHERWISE NOTED.
- TREES TO HAVE A MINIMUM 1800 CLEAR STEM ABOVE GRADE.
- CONTRACTOR TO MAKE GOOD ALL EXISTING AREAS DAMAGED BY HIS WORK TO THE SATISFACTION OF THE CONTRACTOR.
- ALL PLANT MATERIAL SHALL BE WARRANTED FOR TWO YEARS FROM THE DATE OF SUBSTANTIAL COMPLETION.
- CONTRACTOR TO VERIFY LOCATION OF ALL SERVICES PRIOR TO ANY EXCAVATION.
- ANY PROPOSED SUBSTITUTIONS OF PLANT SPECIES SHALL BE MADE WITH PLANTS OF EQUIVALENT OVERALL FORM, HEIGHT, BRANCHING HABIT, FLOWER, LEAF, COLOR, FRUIT AND CULTURE AND ONLY AFTER APPROVAL OF THE LANDSCAPE ARCHITECT.

Contractor shall check all dimensions on the work and report any discrepancy to the Landscape Architect before proceeding. All drawings and specifications are the property of the Landscape Architect and must be returned at the completion of the work. This drawing is not to be used for construction until signed by the Landscape Architect.

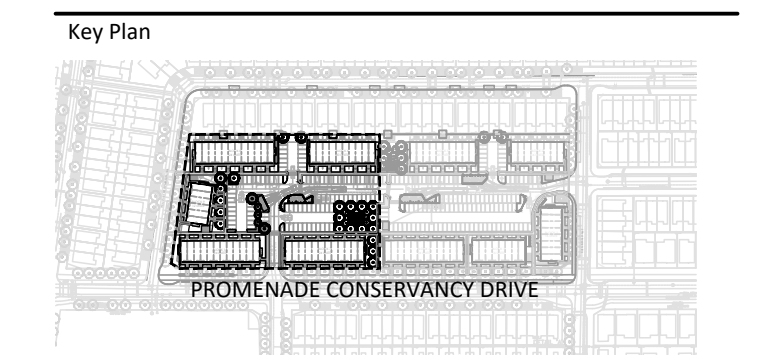

LEGEND

---	PROPERTY LINE
---	FENCING
---	WASTE ENCLOSURE FENCE
---	WOOD PRIVACY FENCE

PLANTING

(Symbol)	MEDIUM DECIDUOUS TREE
(Symbol)	SMALL DECIDUOUS TREE
(Symbol)	DECIDUOUS SHRUB
(Symbol)	CONIFEROUS SHRUB
(Symbol)	GRASSES/PERENNIALS
(Symbol)	SODDING
(Symbol)	SHRUB BED

TREE SOIL VOLUMES

TREE TYPE/SIZE	SINGLE TREE SOIL VOLUME	MULTIPLE TREE SOIL VOLUME (m3/TREE)
ORNAMENTAL	15	9
COLUMNAR	15	9
SMALL	20	12
MEDIUM	25	15
LARGE	30	18
CONIFER	25	15

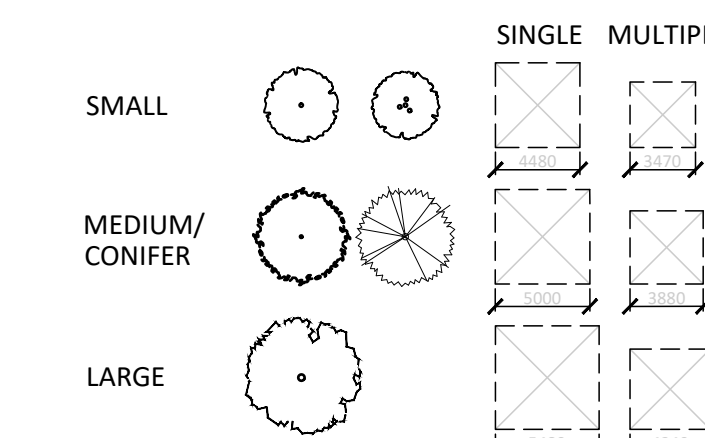

PAVING

(Symbol)	ASPHALT PAVING
(Symbol)	CIP CONCRETE PAVING
(Symbol)	HEAVY DUTY CONCRETE PAVING
(Symbol)	RIVERSTONE PAVING
(Symbol)	UNIT PAVING

PLANTING KEY

(Symbol)	TREE SPECIES QUANTITY
(Symbol)	SHRUB SPECIES QUANTITY

DETAIL KEY

(Symbol)	DETAIL NO.
(Symbol)	SHEET NO.

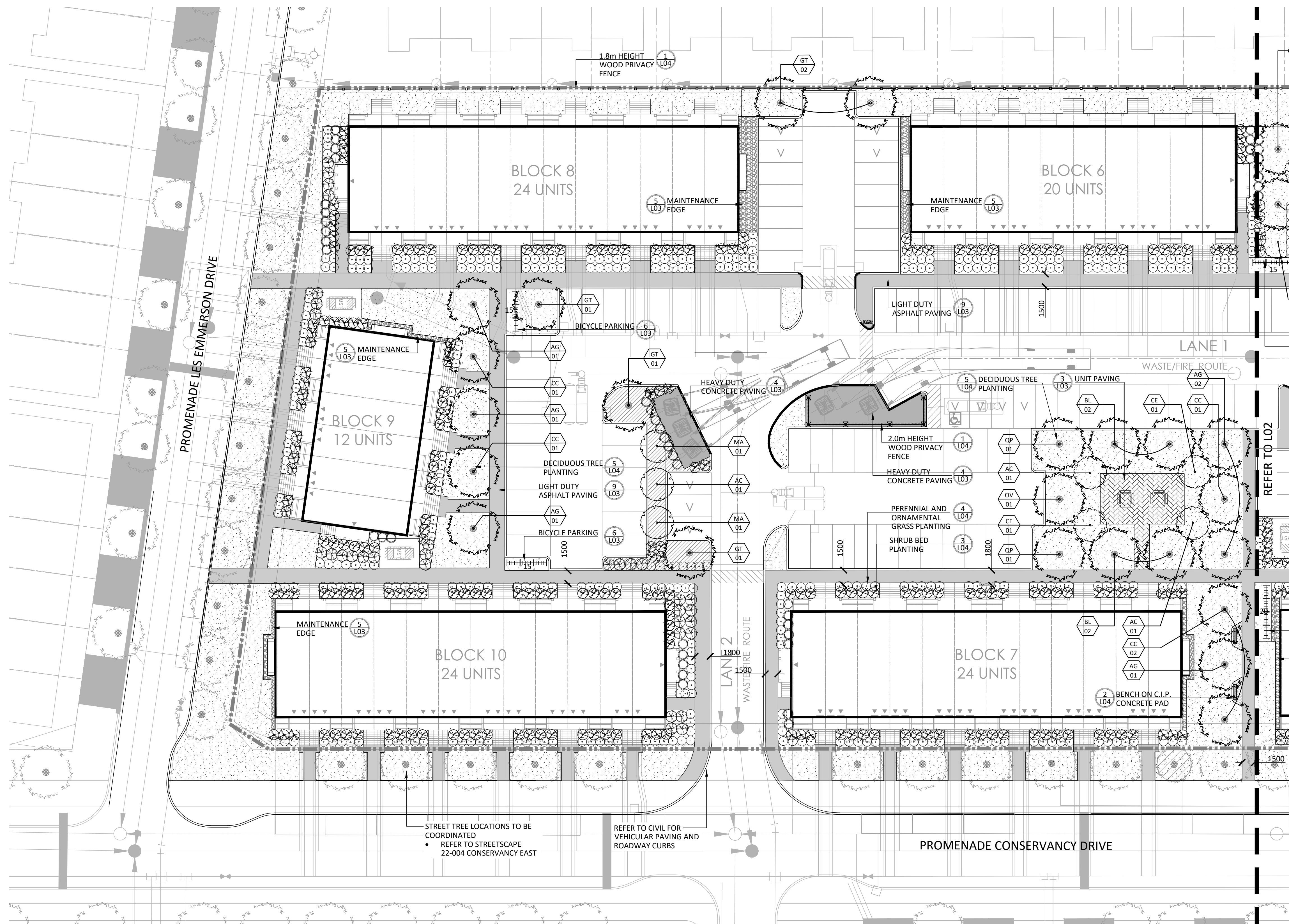

1	Issued for First Submission	Aug 30/24
No.	Description	Date
Revision		
City Approval Stamp		

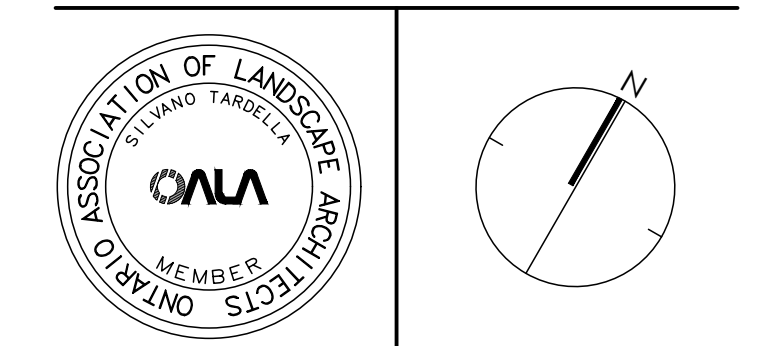

NAK
design strategies

1285 WELLINGTON STREET, OTTAWA, ON K1Y 3A8 CANADA
T 413.237.2345 NAKDESIGNSTRATEGIES.COM

BCDC
OTTAWA, ON

Title
LANDSCAPE PLAN

Date	2024-08-12	Sheet	L01
Scale	1:250	Drawn	SW
Checked	SC		
Job No.	24-154		

KEY	BOTANICAL NAME	COMMON NAME	QUANTITY	SIZE	REMARKS	NATIVE
DECIDUOUS TREES - MEDIUM (8-14M HEIGHT)						
AG	AESULUS GLABRA	OHIO BUCKEYE	6	50mm	B&B	Y
BL	BETULA LENTA	CHERRY BIRCH	6	50mm	B&B	Y
CC	CARPINUS CAROLINIANA	BLUE BEECH	5	50mm	B&B	Y
CK	CLADRATIC KENTUCKEA	YELLOW-WOOD	-	50mm	B&B	Y
GT	GLEDITSIA TRIACANTHOS	HONEY LOCUST	7	50mm	B&B	Y
OV	OSTRYA VIRGINIANA	IRONWOOD	3	50mm	B&B	Y
PP	PRUNUS PENNSYLVANICA	PIN CHERRY	-	50mm	B&B	Y

QP	QUERCUS PRINUS	CHESTNUT OAK	3	50mm	B&B	Y
DECIDUOUS TREES - SMALL (6-8M HEIGHT)						
AC	AMELANCHIER CANADENSIS	SERVICEBERRY	5	50mm	B&B	Y
CE	CERCIS CANADENSIS	EASTERN REDBUD	4	50mm	B&B	Y
MA	MAACKIA AMURENSIS	AMUR MAACKIA	2	50mm	B&B	Y
MS	MALUS SPP.	CRAB APPLE	-	50mm	B&B	Y
MR	MORUS RUBRA	RED MULBERRY	-	50mm	B&B	Y
CONIFEROUS SHRUBS						
Js	JUNIPERUS SCOPULORUM 'WICHITA BLUE'	WITCHITA BLUE JUNIPER	-	3 GAL	POT	Y
Tc	TAXUS CANADENSIS	CANADIAN YEW	-	3 GAL	POT	Y

DECIDUOUS SHRUBS						
Am	ARONIA MELANOCARPA	BLACK CHOKEBERRY	-	3 GAL	POT	Y
Sa	SYMPHORICARPOS ALBUS	SNOWBERRY	-	3 GAL	POT	Y
Po	PHYSOCARPUS OPULIFOLIUS 'DIABOLO'	'DIABOLO' NINEBARK	-	3 GAL	POT	Y
ORNAMENTAL GRASSES						
cl	CHASMANTHIUM LATIFOLIUM	NORTHERN SEA OATS	-	7 GAL	POT	Y
dc	DESCHAMPSIA CESPITOSA	TUFTED HAIR GRASS	-	7 GAL	POT	Y
bg	BOUTELOUA GRACILIS	BLUE GRAMA	-	7 GAL	POT	Y
sh	SPOROBOLUS HETEROLEPSIS	PRARIE DROPSEED	-	7 GAL	POT	Y
ss	SCHIZACHYRIUM SCOPARIUM	LITTLE BLUESTEM	-	7 GAL	POT	Y

GENERAL NOTES:

- ALL PLANT MATERIAL SHALL BE NURSERY GROWN STOCK UNLESS OTHERWISE NOTED.
- TREES TO HAVE A MINIMUM 1800 CLEAR STEM ABOVE GRADE.
- CONTRACTOR TO MAKE GOOD ALL EXISTING AREAS DAMAGED BY HIS WORK TO THE SATISFACTION OF THE CONTRACTOR.
- ALL PLANT MATERIAL SHALL BE WARRANTED FOR TWO YEARS FROM THE DATE OF SUBSTANTIAL COMPLETION.
- CONTRACTOR TO VERIFY LOCATION OF ALL SERVICES PRIOR TO ANY EXCAVATION.
- ANY PROPOSED SUBSTITUTIONS OF PLANT SPECIES SHALL BE MADE WITH PLANTS OF EQUIVALENT OVERALL FORM, HEIGHT, BRANCHING HABIT, FLOWER, LEAF, COLOR, FRUIT AND CULTURE AND ONLY AFTER APPROVAL OF THE LANDSCAPE ARCHITECT.

Contractor shall check all dimensions on the work and report any discrepancy to the Landscape Architect before proceeding. All drawings and specifications are the property of the Landscape Architect and must be returned at the completion of the work. This drawing is not to be used for construction until signed by the Landscape Architect.

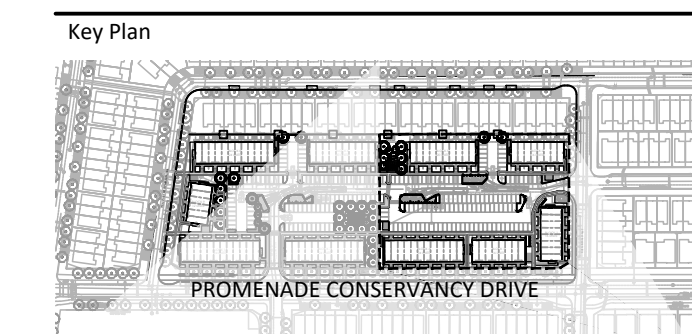

LEGEND

---	PROPERTY LINE
---	FENCING
---	WASTE ENCLOSURE FENCE
---	WOOD PRIVACY FENCE

PLANTING

(Symbol)	MEDIUM DECIDUOUS TREE
(Symbol)	SMALL DECIDUOUS TREE
(Symbol)	DECIDUOUS SHRUB
(Symbol)	CONIFEROUS SHRUB
(Symbol)	GRASSES/PERENNIALS
(Symbol)	SODDING
(Symbol)	SHRUB BED

TREE SOIL VOLUMES

TREE TYPE/SIZE	SINGLE TREE SOIL VOLUME	MULTIPLE TREE SOIL VOLUME (m3/TREE)
ORNAMENTAL	15	9
COLUMNAR	15	9
SMALL	20	12
MEDIUM	25	15
LARGE	30	18
CONIFER	25	15

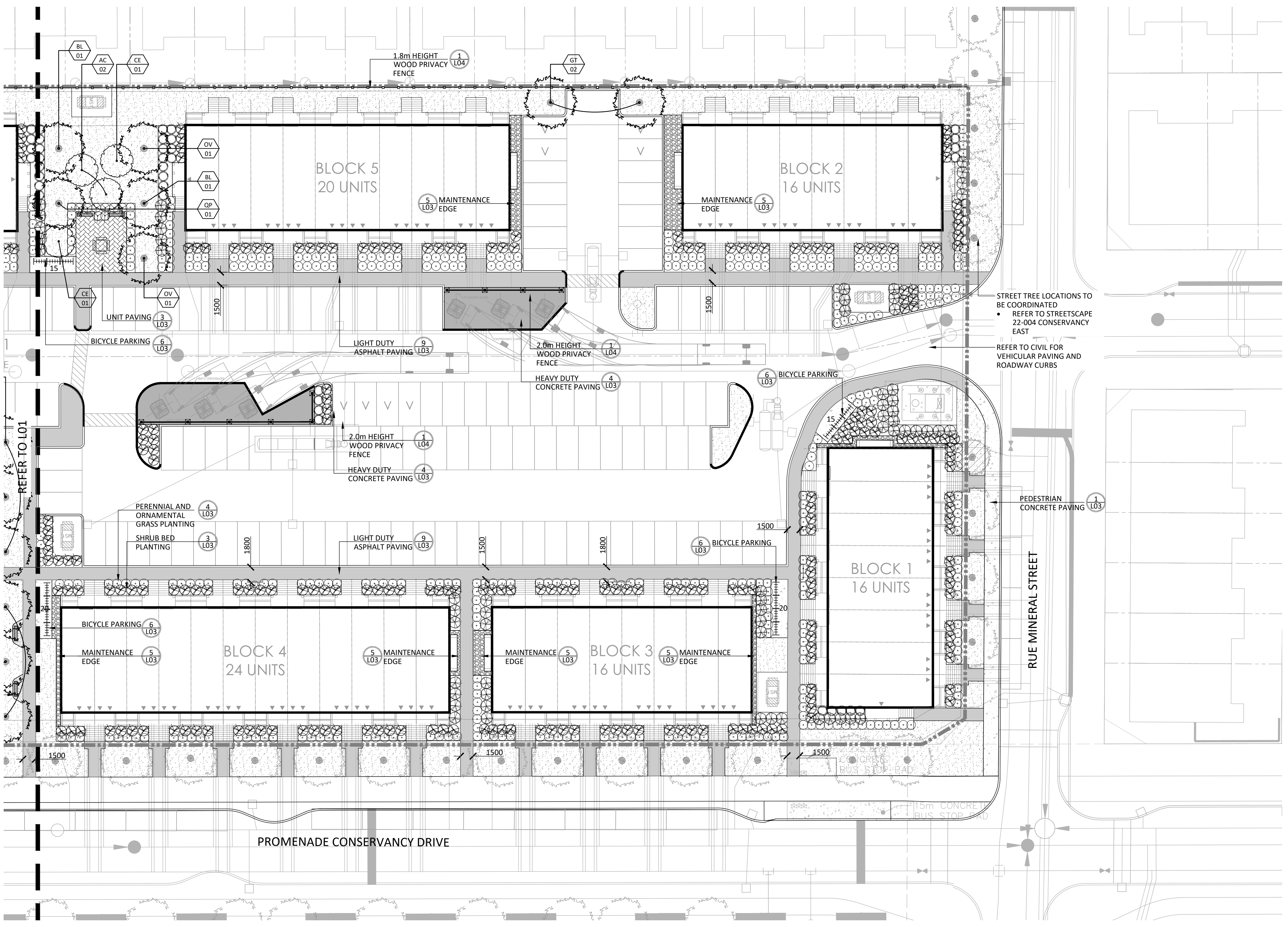
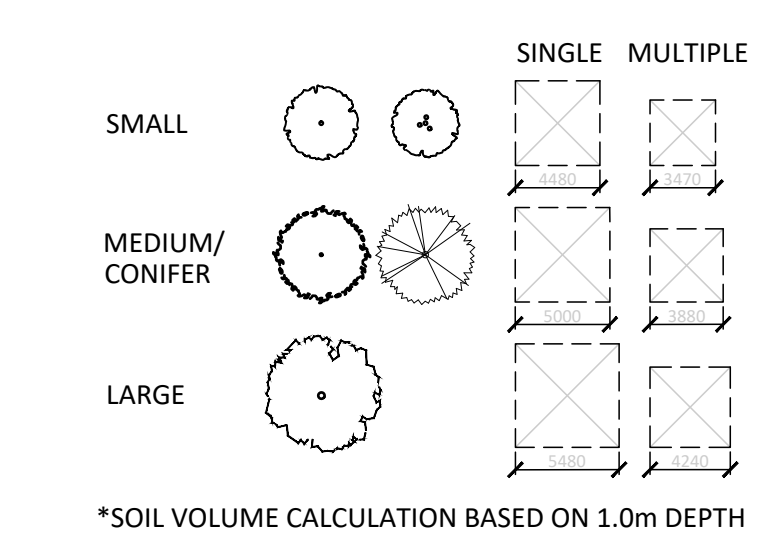

1	Issued for First Submission	Aug 30/24
No.	Description	Date
Revision		
City Approval Stamp		

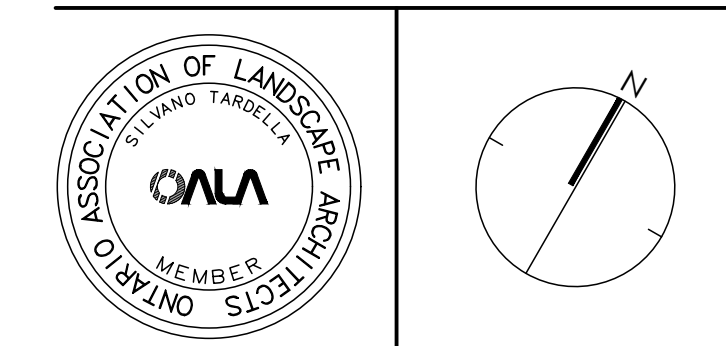

NAK
design strategies
1285 WELLINGTON STREET, OTTAWA, ON K1Y 3A8 CANADA
T 413.237.2345 NAKDESIGNSTRATEGIES.COM

BCDC
OTTAWA, ON

Title
LANDSCAPE PLAN

Date	2024-08-12	Sheet	L02
Scale	1:250	Drawn	SW
Checked	SC		
Job No.	24-154		

Contractor shall check all dimensions on the work and report any discrepancy to the Landscape Architect before proceeding. All drawings and specifications are the property of the Landscape Architect and must be returned at the completion of the work. This drawing is not to be used for construction until signed by the Landscape Architect.

Key Plan

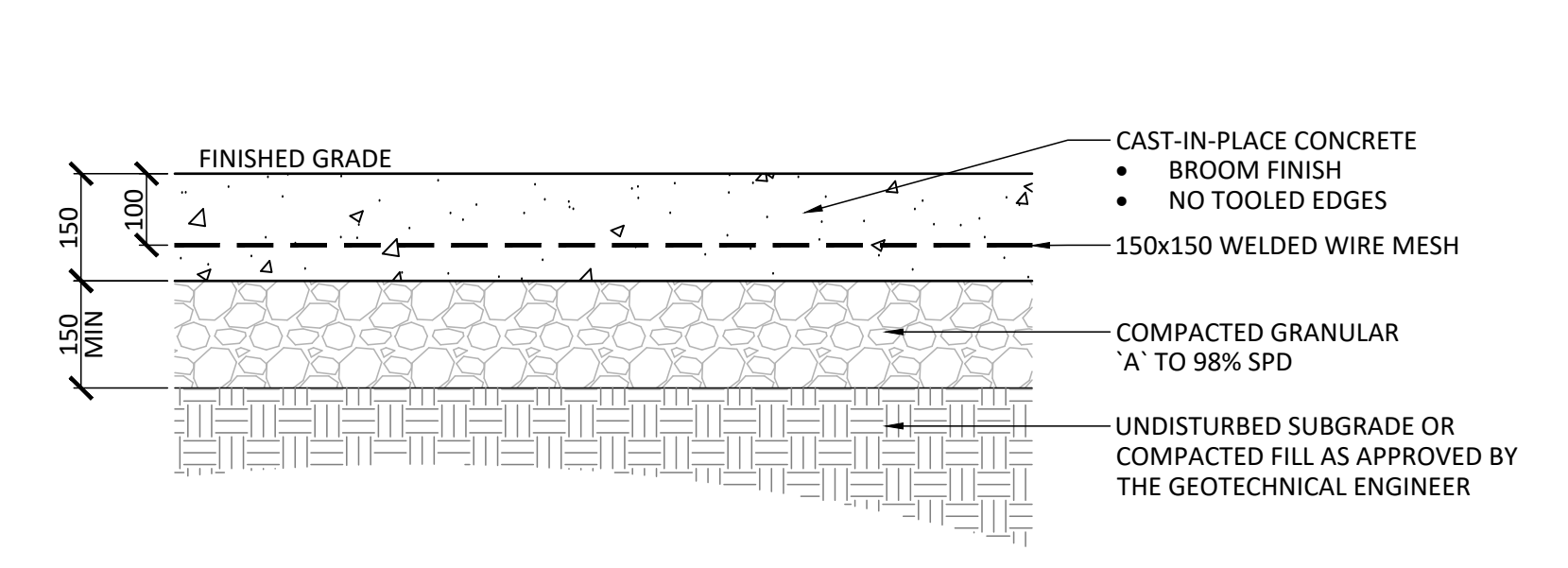

1 PEDESTRIAN CONCRETE PAVING
1:10

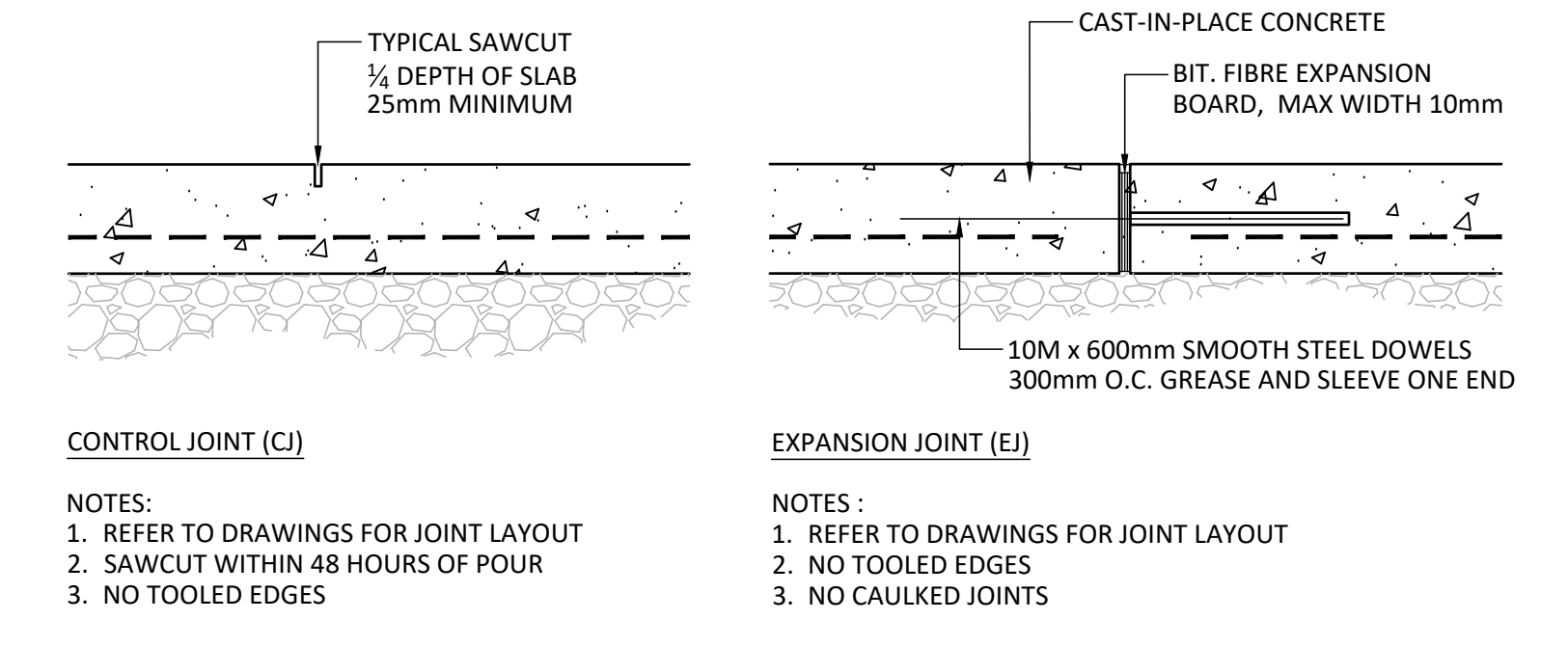

2 PEDESTRIAN CONCRETE JOINTING
1:10

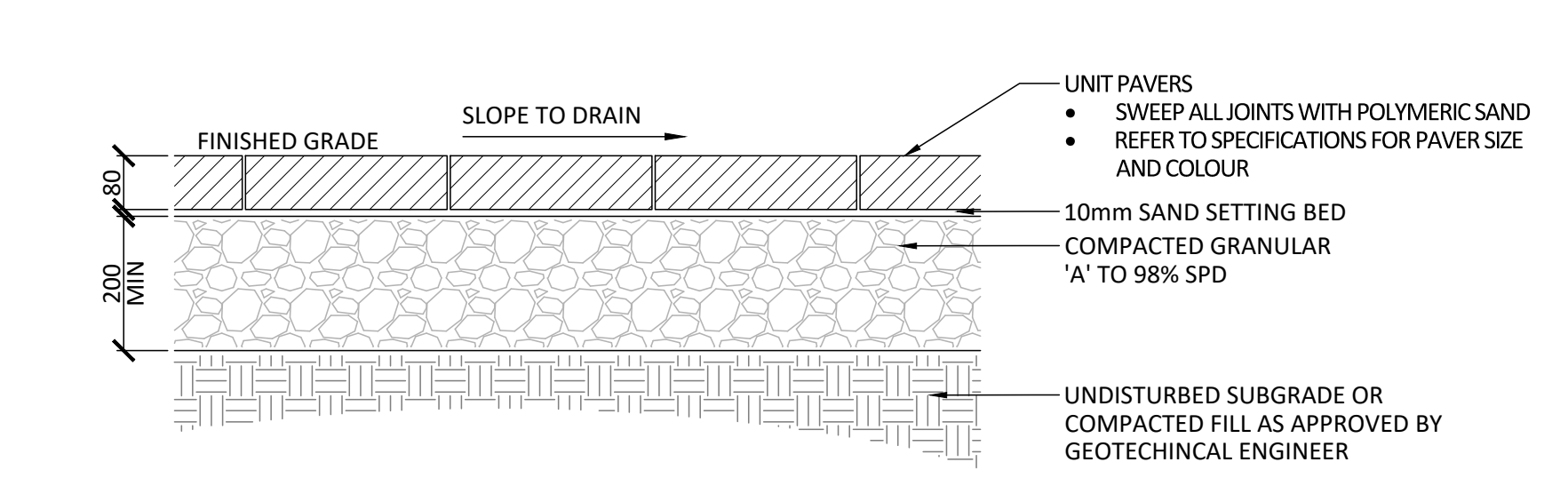

3 UNIT PAVING
1:10

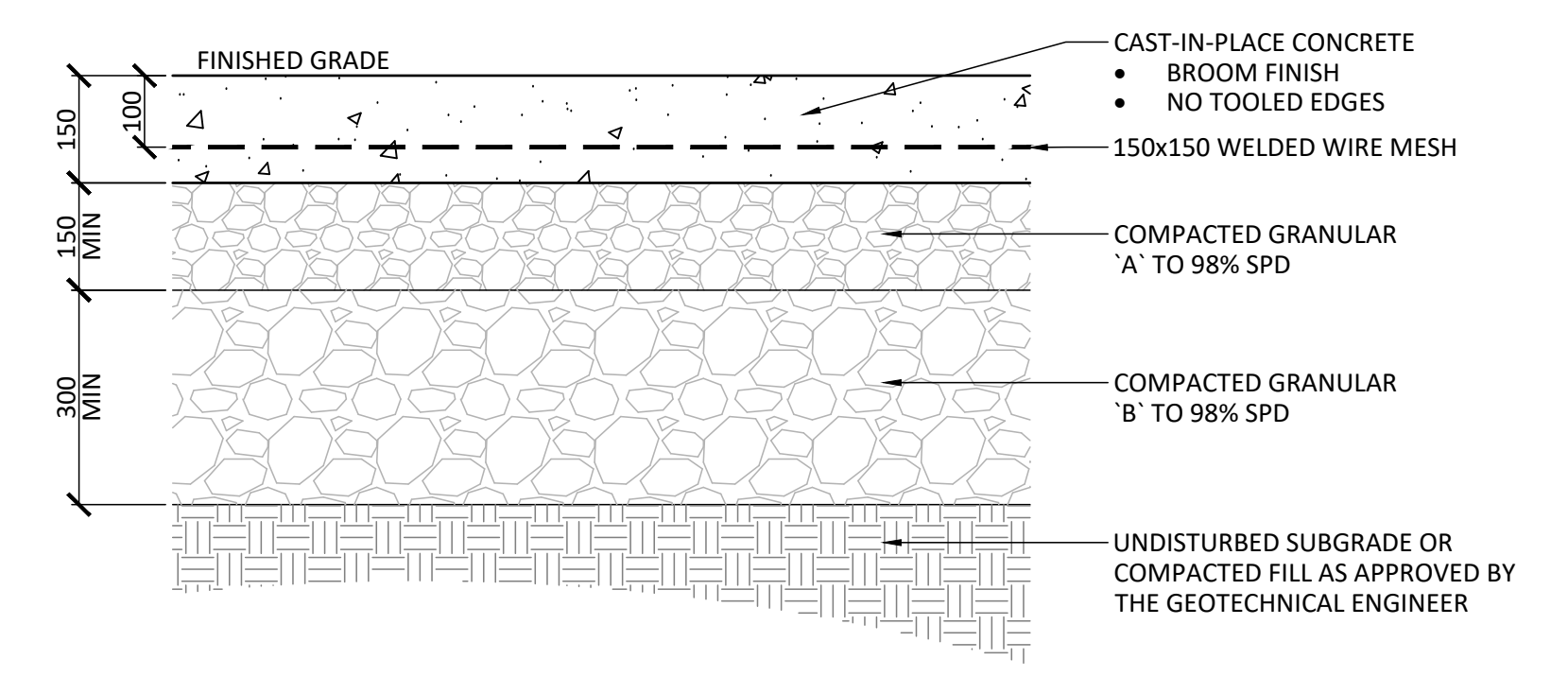

4 HEAVY DUTY CONCRETE PAVING
1:10

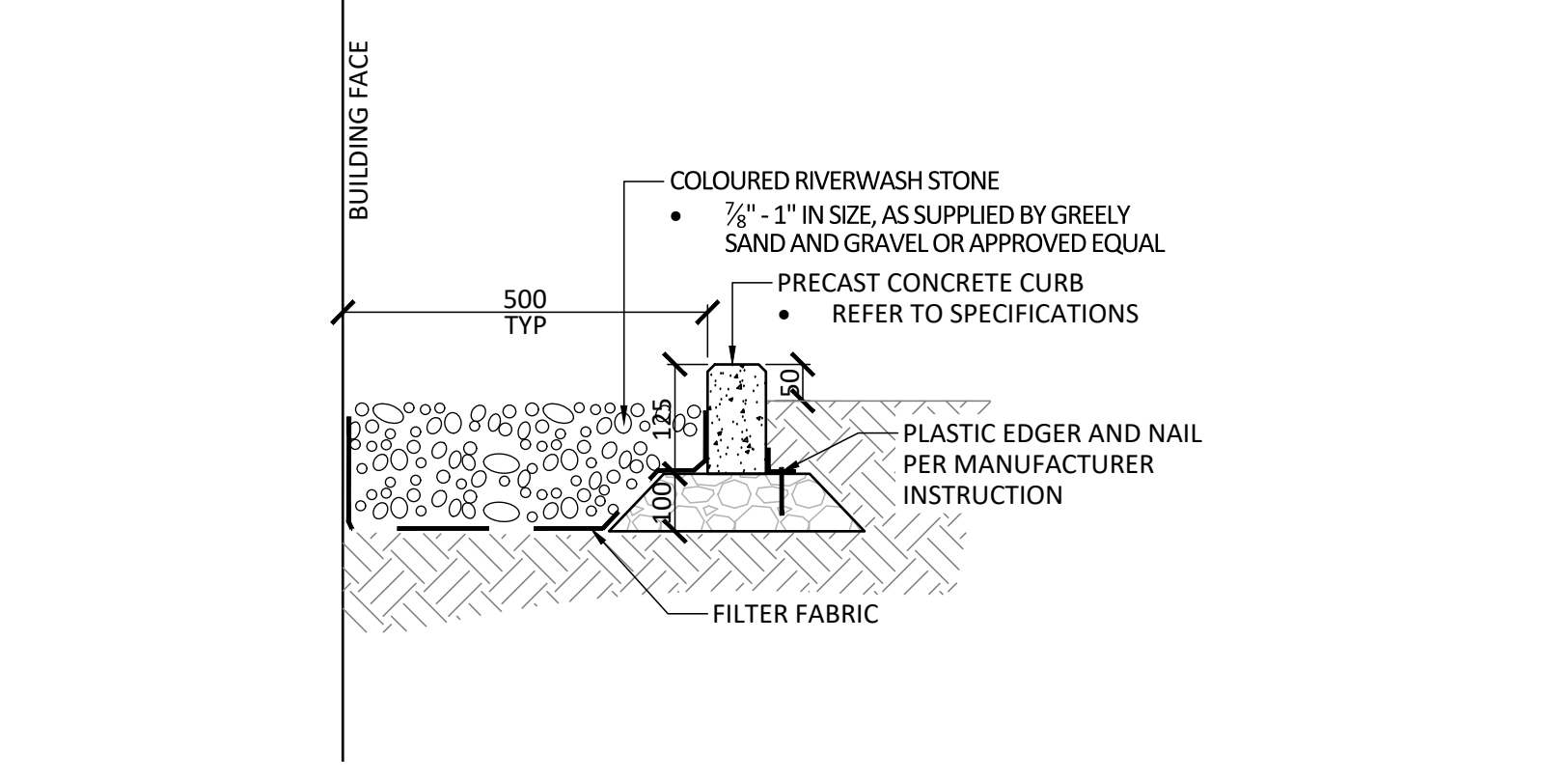

5 MAINTENANCE EDGE
1:10

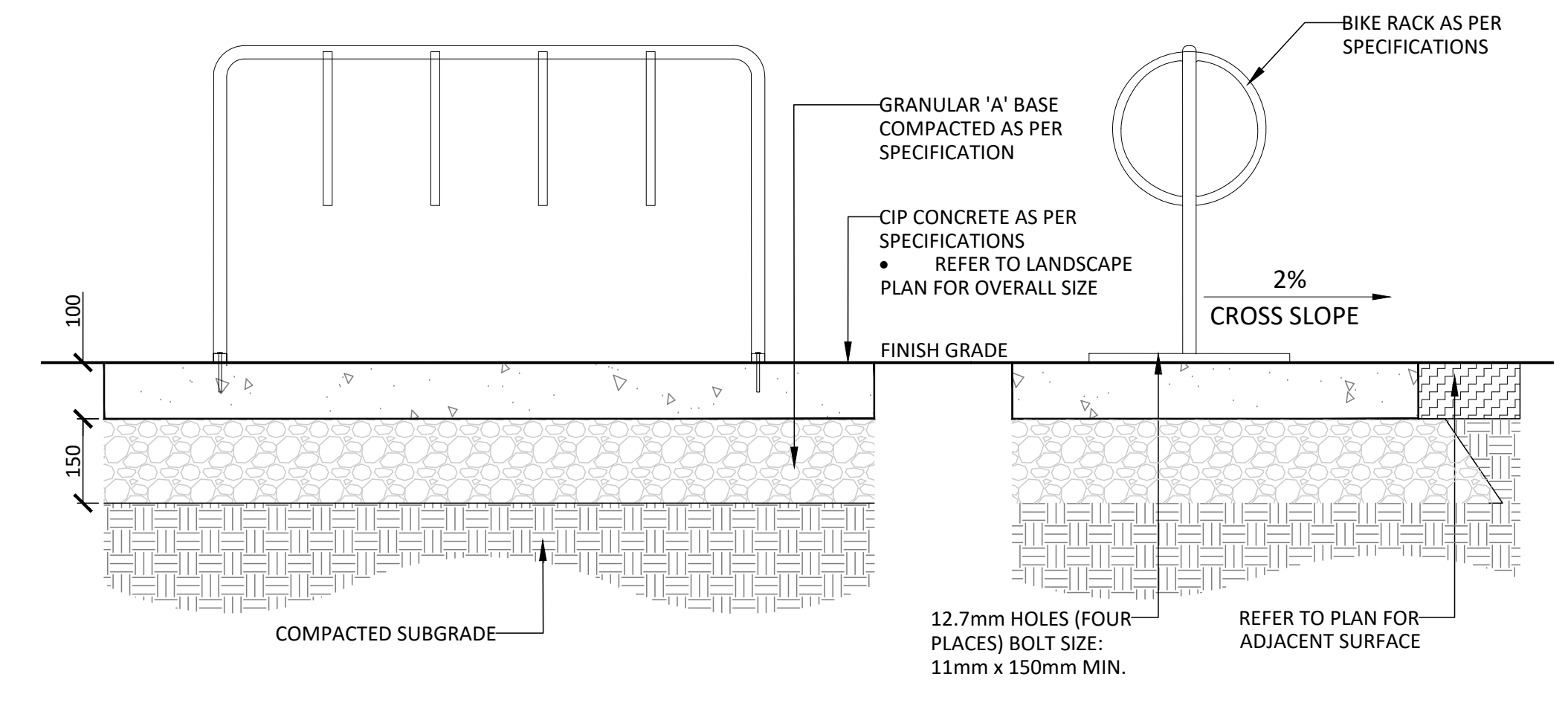

6 BICYCLE PARKING
1:10

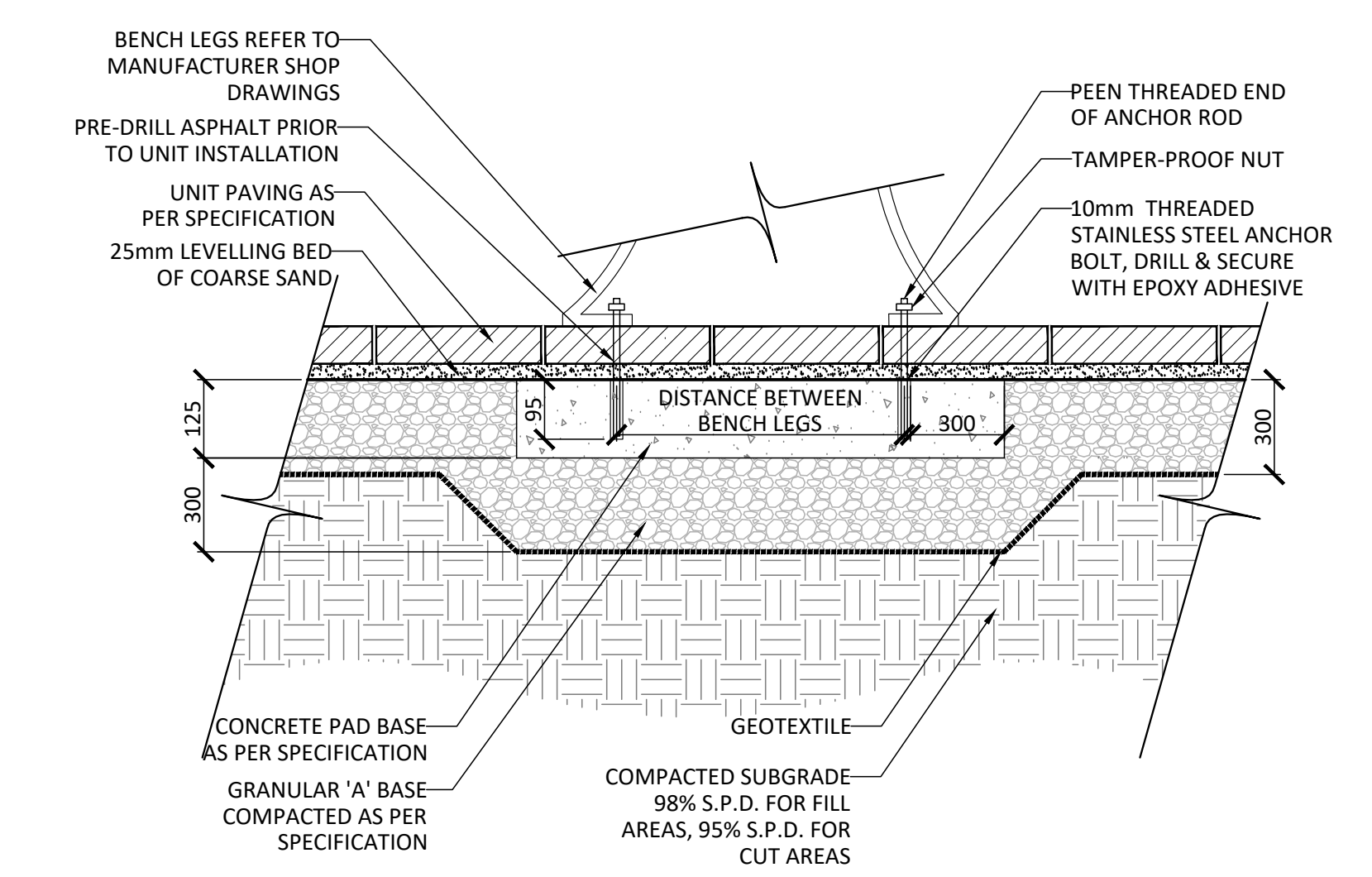

7 BENCH ON UNIT PAVING WITH CONCRETE PAD
1:10

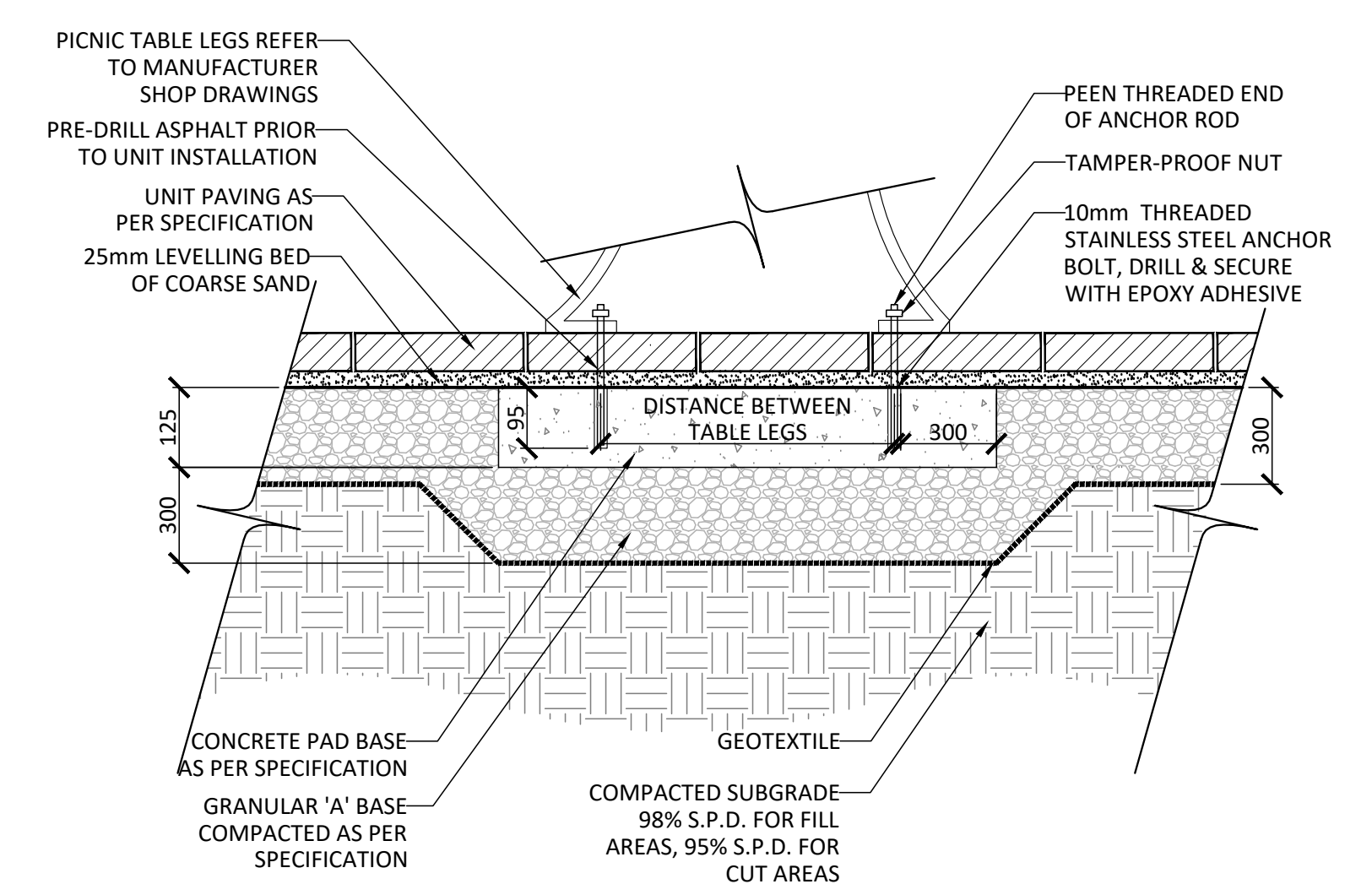

8 PICNIC TABLE ON UNIT PAVING WITH CONCRETE PAD
1:10

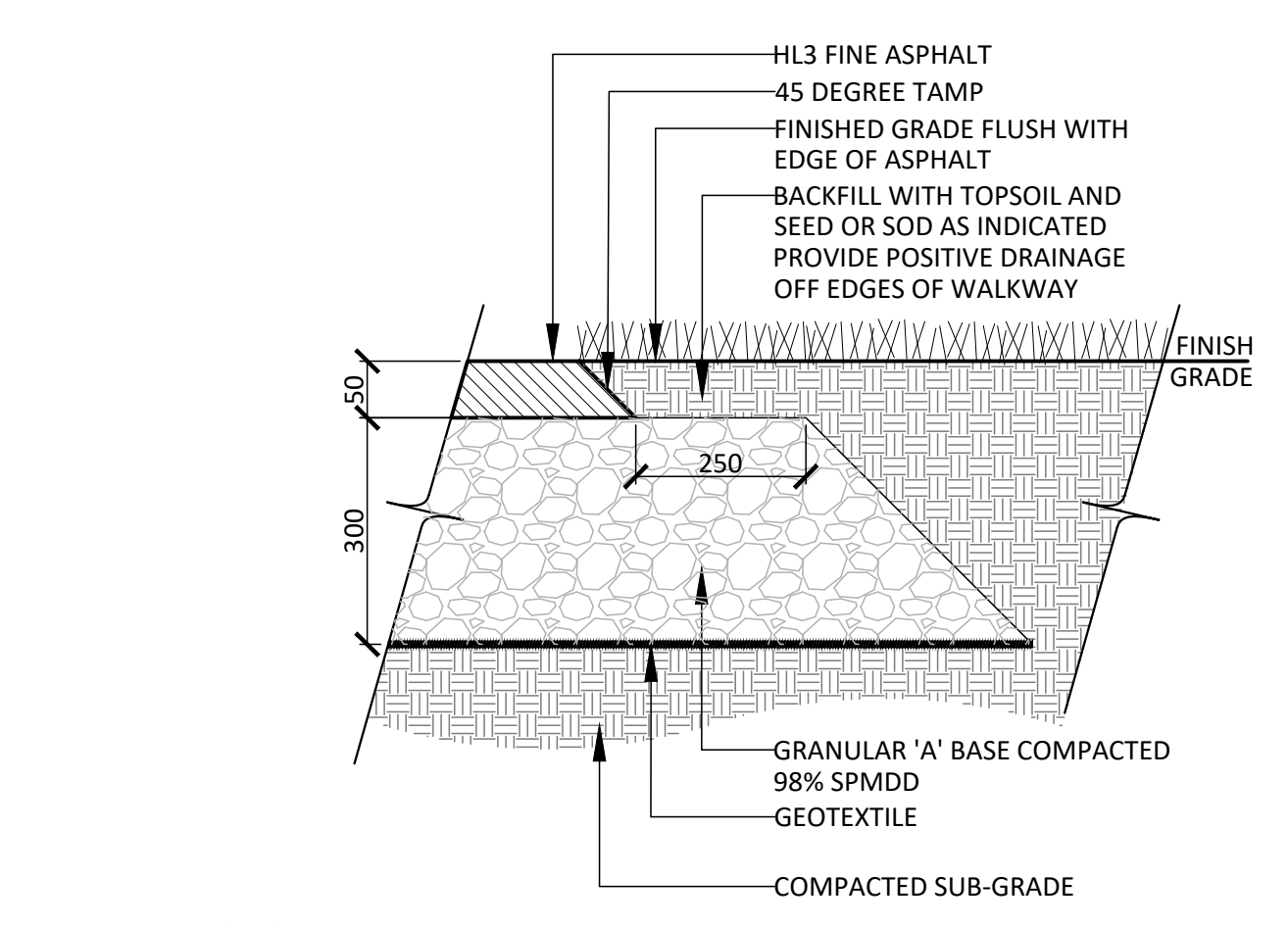

9 LIGHT DUTY ASPHALT PAVING
1:10

1	Issued for First Submission	Aug 30/24
No.	Description	Date
Revision		
City Approval Stamp		

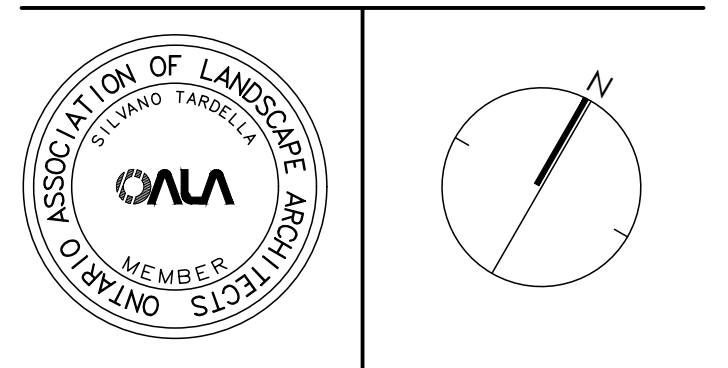

NAK design strategies
1288 WELLINGTON STREET, OTTAWA, ON K1Y 3A8 CANADA
T 416.237.2345 NAKDESIGNSTRATEGIES.COM

BCDC
OTTAWA, ON

Title
LANDSCAPE DETAILS

Date	2024-08-12	Sheet
Scale	AS NOTED	L03
Drawn	SW	
Checked	SC	
Job No.	24-154	

Contractor shall check all dimensions on the work and report any discrepancy to the Landscape Architect before proceeding. All drawings and specifications are the property of the Landscape Architect and must be returned at the completion of the work. This drawing is not to be used for construction until signed by the Landscape Architect.

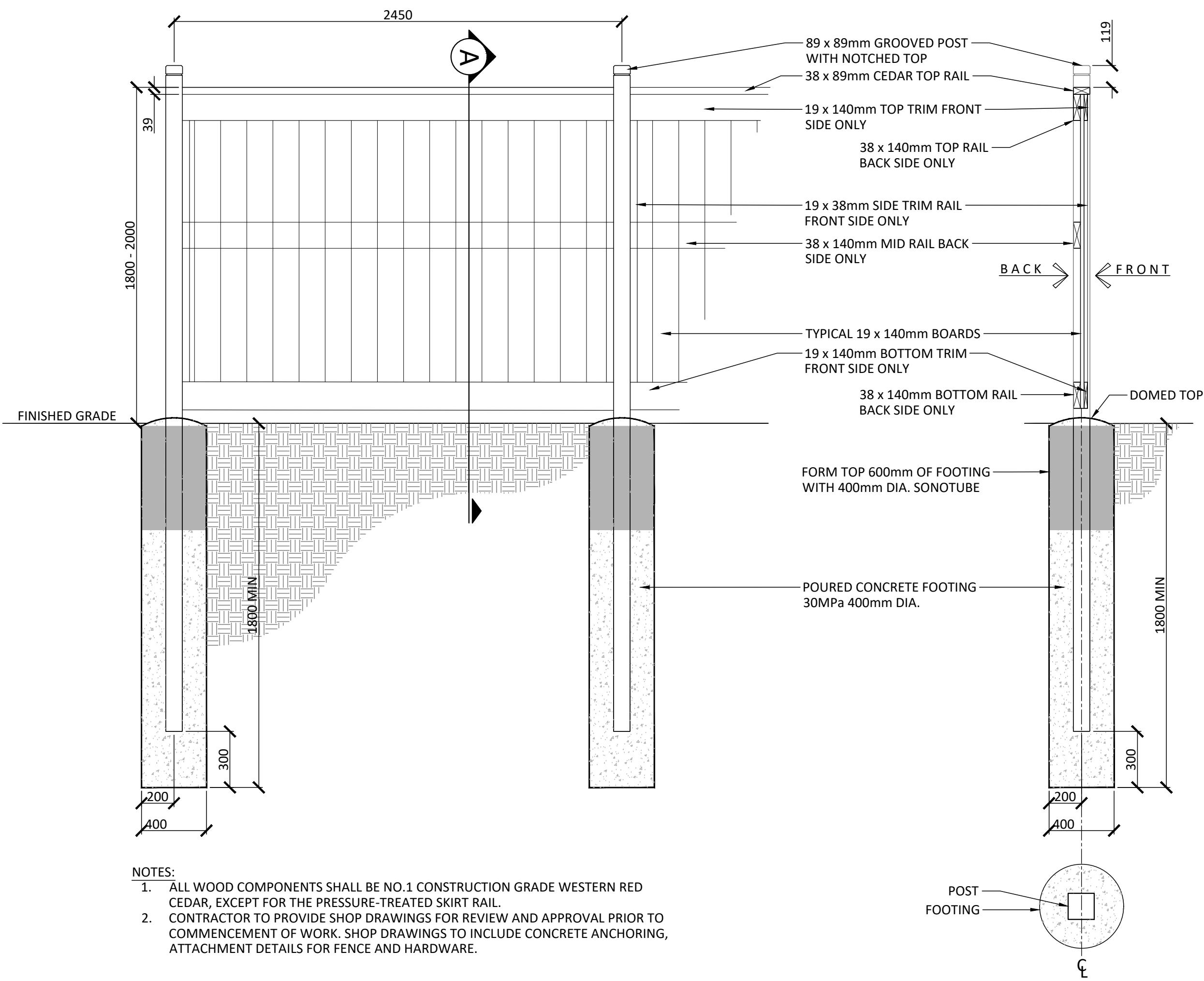

- NOTES:
1. ALL WOOD COMPONENTS SHALL BE NO.1 CONSTRUCTION GRADE WESTERN RED CEDAR, EXCEPT FOR THE PRESSURE-TREATED SKIRT RAIL.
 2. CONTRACTOR TO PROVIDE SHOP DRAWINGS FOR REVIEW AND APPROVAL PRIOR TO COMMENCEMENT OF WORK. SHOP DRAWINGS TO INCLUDE CONCRETE ANCHORING, ATTACHMENT DETAILS FOR FENCE AND HARDWARE.

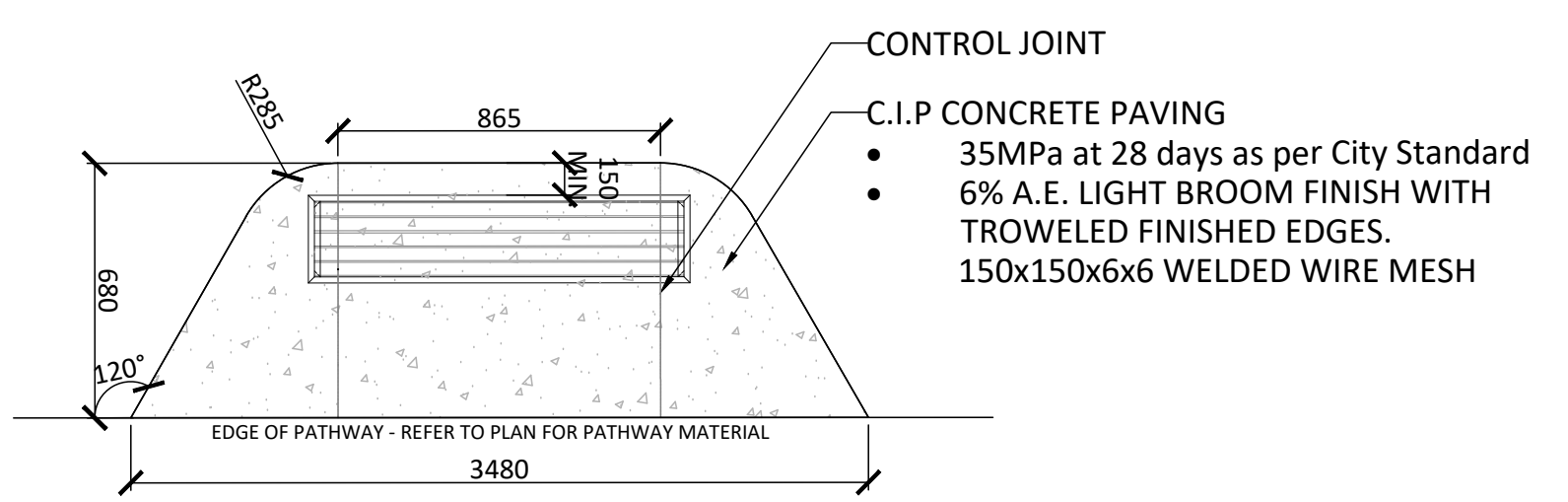
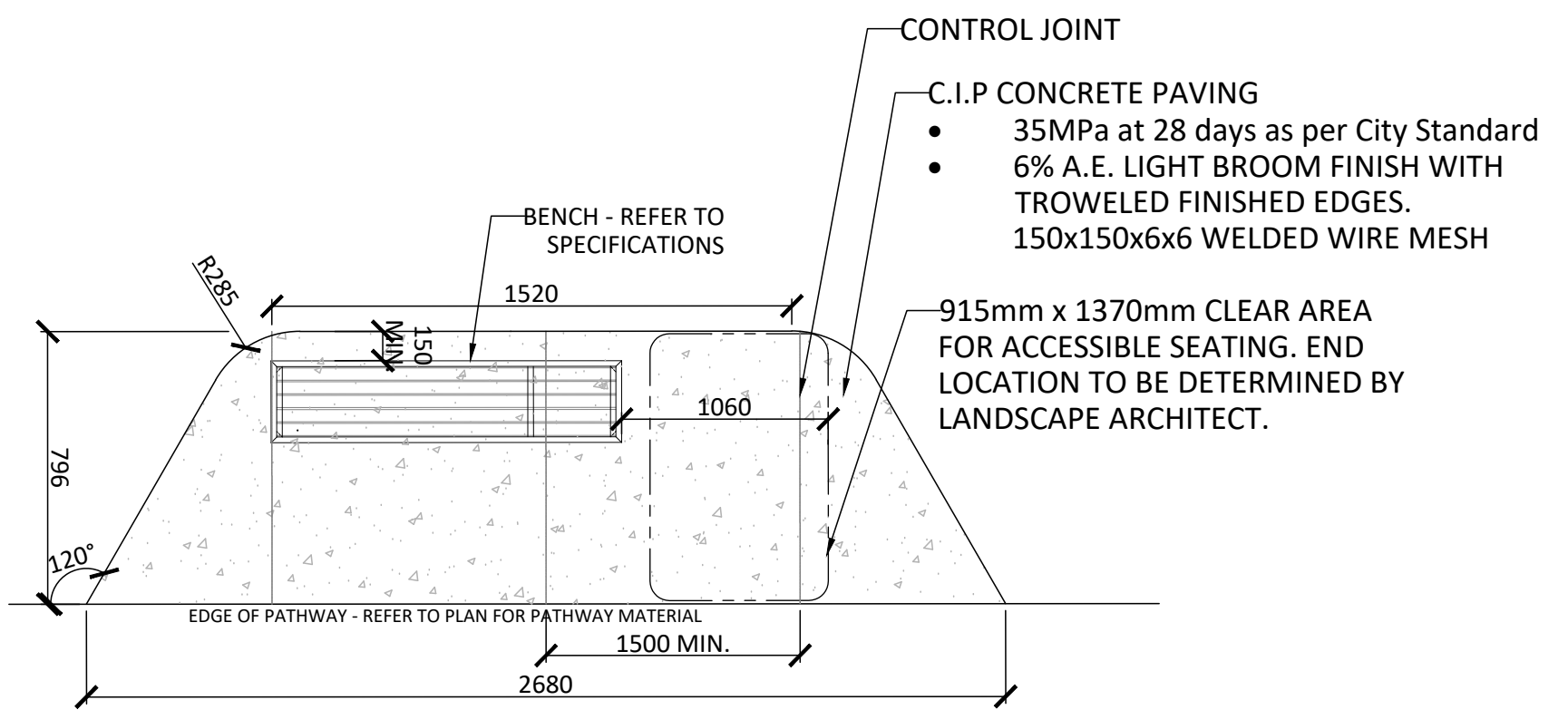

1 1.8m - 2.0m HEIGHT WOOD PRIVACY FENCE
1:20

2 BENCH ON C.I.P. CONCRETE PAD
1:20

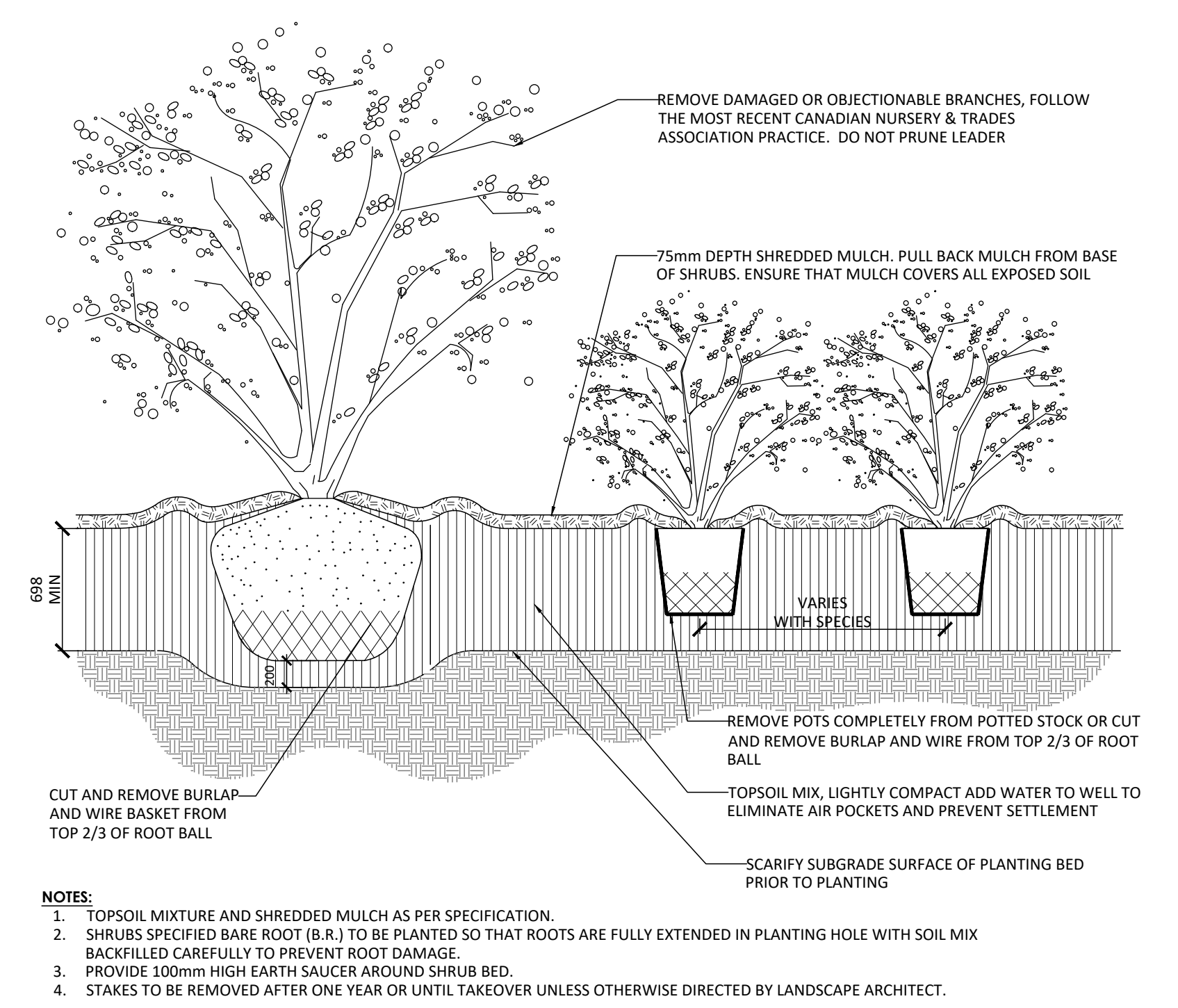

- NOTES:
1. TOPSOIL MIXTURE AND SHREDDED MULCH AS PER SPECIFICATION.
 2. SHRUBS SPECIFIED BARE ROOT (B.R.) TO BE PLANTED SO THAT ROOTS ARE FULLY EXTENDED IN PLANTING HOLE WITH SOIL MIX BACKFILLED CAREFULLY TO PREVENT ROOT DAMAGE.
 3. PROVIDE 100mm HIGH EARTH SAUCER AROUND SHRUB BED.
 4. STAKES TO BE REMOVED AFTER ONE YEAR OR UNTIL TAKEOVER UNLESS OTHERWISE DIRECTED BY LANDSCAPE ARCHITECT.

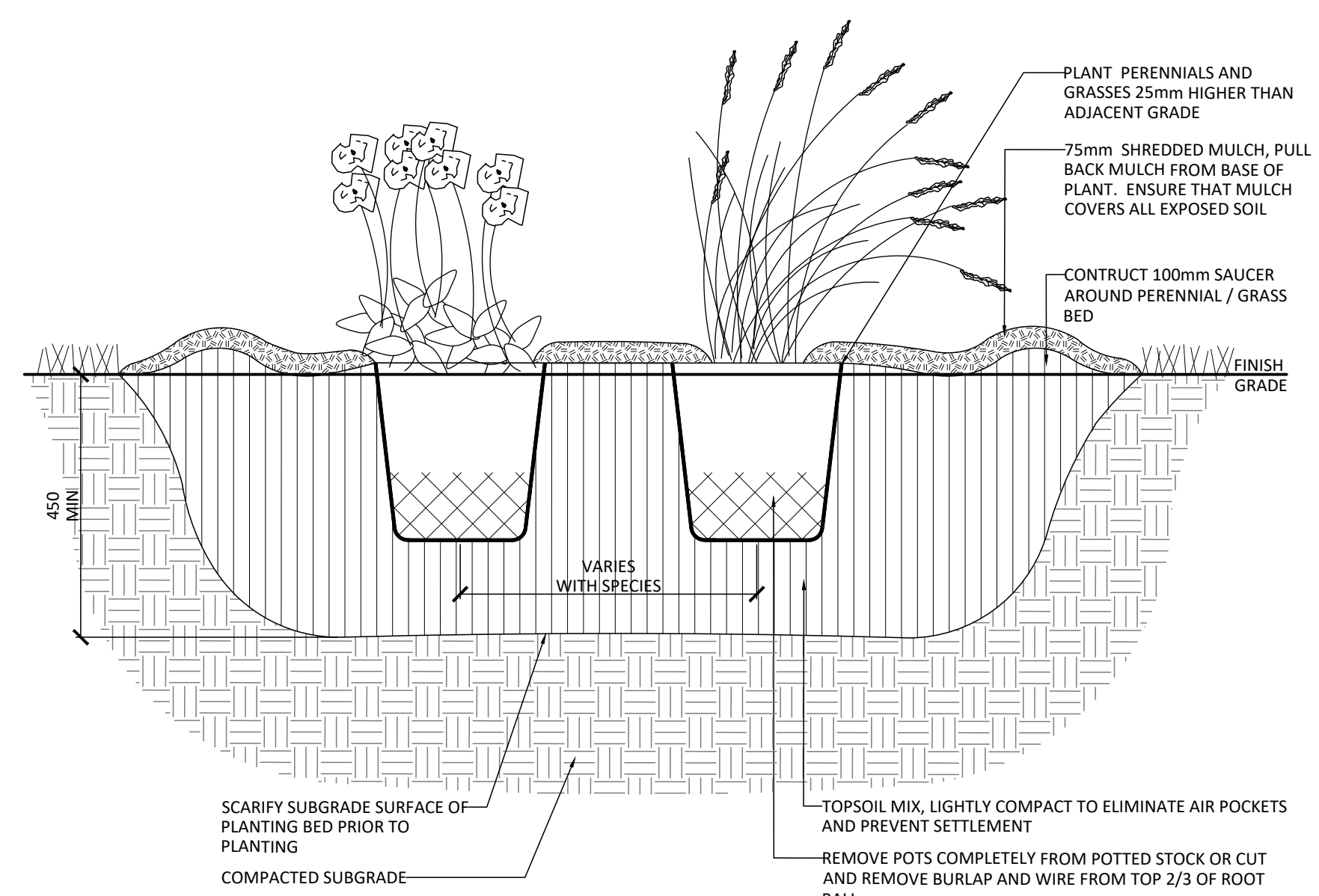

- NOTES:
1. TOPSOIL MIXTURE AND SHREDDED MULCH AS PER SPECIFICATION.
 2. PROVIDE 100mm HIGH EARTH SAUCER AROUND PERENNIAL/GRASS BED.

3 CONTINUOUS SHRUB BED PLANTING (OTT STD-L17, REV 2014)
1:30

4 PERENNIAL AND ORNAMENTAL GRASS PLANTING
1:30

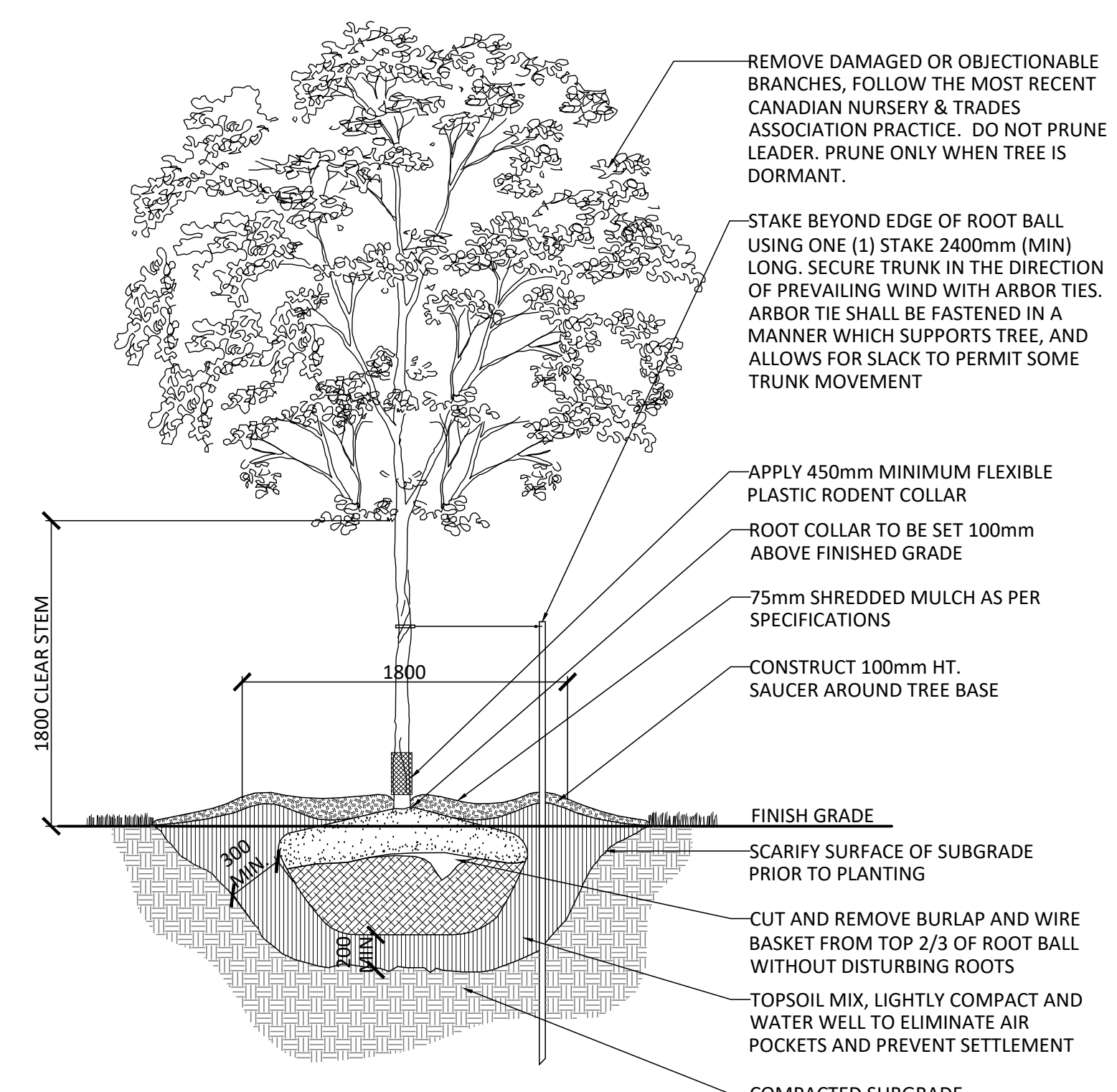

- NOTES:
1. REMOVE STAKE AFTER ONE YEAR OR UNTIL TAKEOVER, UNLESS OTHERWISE DIRECTED BY THE LANDSCAPE ARCHITECT.
 2. TOPSOIL MIXTURE AND SHREDDED MULCH AS PER SPECIFICATION
 3. REMOVE TREE WRAP AFTER PLANTING
 4. CALIPER TO BE MEASURED AT THE BASE OF TREE AT ROOT BALL.

5 DECIDUOUS TREE PLANTING (ONE STAKE W/ARBOR TIES)
1:30

No.	Description	Date
1	Issued for First Submission	Aug 30/24

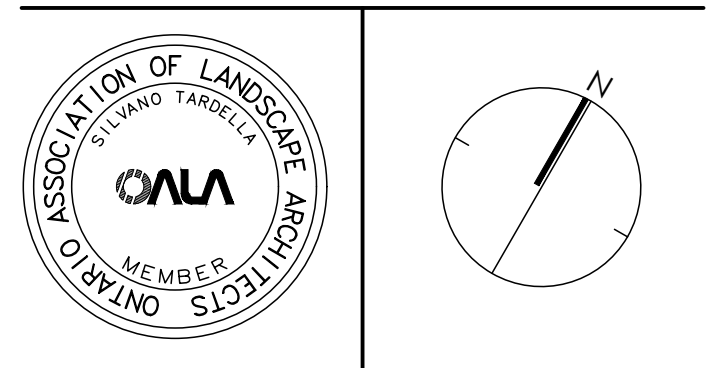

NAK
design strategies
1285 WELLINGTON STREET, OTTAWA, ON K1Y 3A8 CANADA
1 413 237 2345
NAKDESIGNSTRATEGIES.COM

BCDC
OTTAWA, ON

Title
LANDSCAPE DETAILS

Date 2024-08-12
Scale AS NOTED
Drawn SW
Checked SC
Job No. 24-154

Sheet
L04