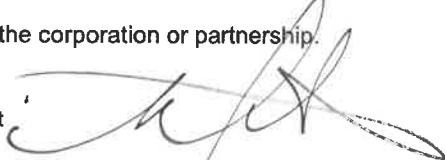

# Application for a Permit to Construct or Demolish

This form is authorized under subsection 8(1.1) of the *Building Code Act, 1992*

For use by Principal Authority			
Application number:		Permit number (if different):	
Date received:		Roll number:	
<p><b>OTTAWA SEPTIC SYSTEM OFFICE</b></p> Application submitted to: _____ (Name of municipality, upper-tier municipality, board of health or conservation authority)			
A. Project information			
Building number, street name		Unit number	Lot/con.
363 ENTREPRENEUR CRESCENT			
Municipality	Postal code	Plan number/other description	
NAVAN (CITY OF OTTAWA)	K4B 1T8		
Project value est. \$		Area of work (m <sup>2</sup> )	
20,000.00		68.04 m <sup>2</sup>	
B. Purpose of application			
<input checked="" type="checkbox"/> New construction	<input type="checkbox"/> Addition to an existing building	<input type="checkbox"/> Alteration/repair	<input type="checkbox"/> Demolition
			<input type="checkbox"/> Conditional Permit
Proposed use of building		Current use of building	
WAREHOUSE w/ OFFICE SPACE		VACANT LOT	
Description of proposed work			
NEW ELJEN SYSTEM FOR WAREHOUSE + OFFICE SPACE.			
C. Applicant			
Applicant is:		<input checked="" type="checkbox"/> Authorized agent of owner	
Last name		First name	Corporation or partnership
DECOEUR		MARC-ANDRÉ	ABSOLUTE DRAFTING + DESIGN INC.
Street address		Unit number	Lot/con.
1257 MONTÉE DROUIN			
Municipality	Postal code	Province	E-mail
THE NATION (CASSELMAN)	K0A 1M0	ONTARIO	INFO@ADND.CA
Telephone number	Fax	Cell number	
(613) 434-2844	( )	(613) 229-0869	
D. Owner (if different from applicant)			
Last name		First name	Corporation or partnership
WILSON		DUSTIN	ENTREPRENEUR HOLDING CORPORATION
Street address		Unit number	Lot/con.
310 SANCTUARY PVT			
Municipality	Postal code	Province	E-mail
OTTAWA	K1S 5W1	ONTARIO	justdustinwilson@gmail.com
Telephone number	Fax	Cell number	
( )	( )	(613) 700-5262	

Application for a Permit to Construct or Demolish – Effective January 1, 2014

<b>E. Builder (optional)</b>			
Last name	First name	Corporation or partnership (if applicable)	
UNKNOWN @ TIME OF APPLICATION.			
Street address		Unit number	Lot/con.
Municipality	Postal code	Province	E-mail
Telephone number ( )	Fax ( )	Cell number ( )	
<b>F. Tarion Warranty Corporation (Ontario New Home Warranty Program)</b>			
i. Is proposed construction for a new home as defined in the <i>Ontario New Home Warranties Plan Act</i> ? If no, go to section G.		Yes	No ✓
ii. Is registration required under the <i>Ontario New Home Warranties Plan Act</i> ?		Yes	No ✓
iii. If yes to (ii) provide registration number(s): _____			
<b>G. Required Schedules</b>			
i) Attach Schedule 1 for each individual who reviews and takes responsibility for design activities.			
ii) Attach Schedule 2 where application is to construct on-site, install or repair a sewage system.			
<b>H. Completeness and compliance with applicable law</b>			
i) This application meets all the requirements of clauses 1.3.1.3 (5) (a) to (d) of Division C of the Building Code (the application is made in the correct form and by the owner or authorized agent, all applicable fields have been completed on the application and required schedules, and all required schedules are submitted).		Yes ✓	No
Payment has been made of all fees that are required, under the applicable by-law, resolution or regulation made under clause 7(1)(c) of the <i>Building Code Act, 1992</i> , to be paid when the application is made.		Yes ✓	No
ii) This application is accompanied by the plans and specifications prescribed by the applicable by-law, resolution or regulation made under clause 7(1)(b) of the <i>Building Code Act, 1992</i> .		Yes ✓	No
iii) This application is accompanied by the information and documents prescribed by the applicable by-law, resolution or regulation made under clause 7(1)(b) of the <i>Building Code Act, 1992</i> which enable the chief building official to determine whether the proposed building, construction or demolition will contravene any applicable law.		Yes ✓	No
iv) The proposed building, construction or demolition will not contravene any applicable law.		Yes ✓	No
<b>I. Declaration of applicant</b>			
I <u>MARC-ANDRÉ DECOEUR [ABSOLUTE DRAFTING + DESIGN INC.]</u> (print name)		declare that:	
1. The information contained in this application, attached schedules, attached plans and specifications, and other attached documentation is true to the best of my knowledge.			
2. If the owner is a corporation or partnership, I have the authority to bind the corporation or partnership.			
Date	<u>April 19, 2023</u>	Signature of applicant	

Personal information contained in this form and schedules is collected under the authority of subsection 8(1.1) of the *Building Code Act, 1992*, and will be used in the administration and enforcement of the *Building Code Act, 1992*. Questions about the collection of personal information may be addressed to: a) the Chief Building Official of the municipality or upper-tier municipality to which this application is being made, or, b) the inspector having the powers and duties of a chief building official in relation to sewage systems or plumbing for an upper-tier municipality, board of health or conservation authority to whom this application is made, or, c) Director, Building and Development Branch, Ministry of Municipal Affairs and Housing 777 Bay St., 2nd Floor. Toronto, M5G 2E5 (416) 585-6666.

# Schedule 1: Designer Information

Use one form for each individual who reviews and takes responsibility for design activities with respect to the project.

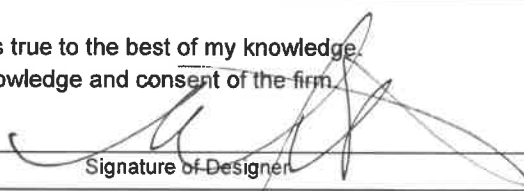
A. Project Information			
Building number, street name <i>363 ENTREPRENEUR CRESCENT</i>	Unit no.	Lot/con.	
Municipality <i>NAPAN [OTTAWA]</i>	Postal code <i>K4B 1T8</i>	Plan number/ other description	
B. Individual who reviews and takes responsibility for design activities			
Name <b>MARC-ANDRE DECOEUR</b>		Firm <b>ABSOLUTE DRAFTING + DESIGN INC</b>	
Street address <b>1257 MONTEE DROUIN</b>		Unit no.	Lot/con.
Municipality <b>THE NATION</b>	Postal code <b>K0A 1M0</b>	Province <b>ONTARIO</b>	E-mail <b>INFO@ADND.CA</b>
Telephone number <b>613-434-2844 EXT. 1001</b>	Fax number	Cell number <b>613-229-0869</b>	
C. Design activities undertaken by individual identified in Section B. [Building Code Table 3.5.2.1. of Division C]			
<input checked="" type="checkbox"/> House	<input checked="" type="checkbox"/> HVAC – House	<input checked="" type="checkbox"/> Building Structural	
<input checked="" type="checkbox"/> Small Buildings	<input checked="" type="checkbox"/> Building Services	<input checked="" type="checkbox"/> Plumbing – House	
<input checked="" type="checkbox"/> Large Buildings	<input checked="" type="checkbox"/> Detection, Lighting and Power	<input checked="" type="checkbox"/> Plumbing – All Buildings	
<input checked="" type="checkbox"/> Complex Buildings	<input type="checkbox"/> Fire Protection	<input checked="" type="checkbox"/> On-site Sewage Systems	
Description of designer's work  <i>NEW ELJON SYSTEM FOR WAREHOUSE + OFFICE SPACE -</i>			
D. Declaration of Designer			
I <u>MARC-ANDRE DECOEUR (ABSOLUTE DRAFTING + DESIGN INC.)</u> declare that (choose one as appropriate): <div style="text-align: center;">(print name)</div>			
I review and take responsibility for the design work on behalf of a firm registered under subsection 3.2.4. of Division C, of the Building Code. I am qualified, and the firm is registered, in the appropriate classes/categories.			
Individual BCIN: <u>44555</u>			
Firm BCIN: <u>45254</u>			
I review and take responsibility for the design and am qualified in the appropriate category as an "other designer" under subsection 3.2.5. of Division C, of the Building Code.			
Individual BCIN: _____			
Basis for exemption from registration: _____			
The design work is exempt from the registration and qualification requirements of the Building Code.			
Basis for exemption from registration and qualification: _____			
I certify that:			
1. The information contained in this schedule is true to the best of my knowledge.			
2. I have submitted this application with the knowledge and consent of the firm.			
<u>April 19, 2023</u> Date		 Signature of Designer	

**NOTE:**

1. For the purposes of this form, "individual" means the "person" referred to in Clause 3.2.4.7(1) (c) of Division C, Article 3.2.5.1. of Division C, and all other persons who are exempt from qualification under Subsections 3.2.4. and 3.2.5. of Division C.
2. Schedule 1 is not required to be completed by a holder of a license, temporary license, or a certificate of practice, issued by the Ontario Association of Architects. Schedule 1 is also not required to be completed by a holder of a license to practise, a limited license to practise, or a certificate of authorization, issued by the Association of Professional Engineers of Ontario.

## Schedule 2: Sewage System Installer Information

A. Project Information			
Building number, street name <i>363 ENTREPRENEUR (RECENT)</i>		Unit number	Lot/con.
Municipality <i>NAVAN [OTTAWA]</i>	Postal code <i>K4B 1T8</i>	Plan number/ other description	
B. Sewage system installer			
Is the installer of the sewage system engaged in the business of constructing on-site, installing, repairing, servicing, cleaning or emptying sewage systems, in accordance with Building Code Article 3.3.1.1, Division C?			
Yes (Continue to Section C)		No (Continue to Section E)	
		<input checked="" type="checkbox"/> Installer unknown at time of application (Continue to Section E)	
C. Registered installer information (where answer to B is "Yes")			
Name		BCIN	
Street address		Unit number	Lot/con.
Municipality	Postal code	Province	E-mail
Telephone number ( )	Fax ( )	Cell number ( )	
D. Qualified supervisor information (where answer to section B is "Yes")			
Name of qualified supervisor(s)		Building Code Identification Number (BCIN)	
E. Declaration of Applicant:			
<p>I <u><i>MARC-ANDRÉ DÉCOEUR [ABSOLUTE DRAFTING + DESIGN INC.]</i></u> (print name) declare that:</p> <p><input checked="" type="checkbox"/> I am the applicant for the permit to construct the sewage system. If the installer is unknown at time of application, I shall submit a new Schedule 2 prior to construction when the installer is known;</p> <p><u>OR</u></p> <p>I am the holder of the permit to construct the sewage system, and am submitting a new Schedule 2, now that the installer is known.</p> <p>I certify that:</p> <ol style="list-style-type: none"> <li>1. The information contained in this schedule is true to the best of my knowledge.</li> <li>2. If the owner is a corporation or partnership, I have the authority to bind the corporation or partnership.</li> </ol> <p style="display: flex; justify-content: space-between; margin-top: 20px;"> <span>Date <i>April 19, 2023</i></span> <span>Signature of applicant </span> </p>			



Do Not Complete
Permit # _____
Revision # _____
Date _____

## Schedule 4 Proposed Services Complete Sections 1 thru 7

**1. Engineered**

- Yes
- No

**2. Water supply**

- Proposed
- Existing

**3. Type of work proposed**

- New Installation
- Replacement
- Alteration

**4. Type of Well**

- Dug/bored/Sandpoint well
- Drilled well
- Municipal
- Other

**5. Residential Sewage Design Flow Info.**

Bedrooms \_\_\_\_\_  
 House (floor area) \_\_\_\_\_ m<sup>2</sup>  
 People \_\_\_\_\_  
 Total Fixture Units \_\_\_\_\_ (Schedule 8)  
 Residential Flow \_\_\_\_\_ L/day

**6. Sewage Design Flow Other Occupancies**

Design Flow 1310 L/day  
 Detailed sewage flow calculations:

SEE "FLOW CALCULATION" DRAWING.

**7. Type of System**

- Treatment Unit \_\_\_\_\_
- Class 2 – Leaching Pit
- Class 3 – Cesspool
- Class 4 – Shallow Buried Trench

---

- Class 4 – Trench (Schedule 9)
  - Fully raised
  - Partially raised
  - In-ground
- Class 4 – Filter Media (Schedule 10)
  - Fully raised
  - Partially raised
  - In-ground

- Class 4 – BMEC Area Bed (Schedule 11)

→ ELJEN

- Fully raised
- Partially raised
- In-ground
- Class 4 – “Type A” Dispersal (Schedule 13)
  - Fully raised
  - Partially raised
  - In-ground
- Class 4 – “Type B” Dispersal (Schedule 14)
  - Fully raised
  - Partially raised
  - In-ground
- Class 5 – Holding Tank (9000L min)
- Tank/TreatmentUnit/PumpChamber ONLY
- Effluent Filter/Risers ONLY



Do Not Complete  
 Permit No \_\_\_\_\_  
 Revision No \_\_\_\_\_  
 Date \_\_\_\_\_

### Schedule 5 Sewage System Details

Type of System ELJEN SYSTEM (Schedule 4)  
 Septic/Holding Tank Size: 5509 Litres Make: LOW-BOY CONCRETE (PROPOSED)  
 Septic Tank Effluent Filter Make: POLYLOK Model: PL 525 OR EQUIVALENT.

Treatment Unit – Make & Model ELJEN GSF A42 MODULES

Number of Units: 14 Other: \_\_\_\_\_

Refer to Typical Drawing # FLOW CALCULATIONS. Pump(s) required YES.

Mantle Information: Pump Rate \_\_\_\_\_ L/15min

Native or imported =15m in \_\_\_\_\_ direction(s) **Note: Alarm required for all pumping systems**

Slope subgrade 2% MIN. % slope 3 DOSING PER DAY  
NORTH. direction(s) @ 163.8 LITER PER DOSING  
\*SEE SEPTIC SECTION FOR CALCULATION.

Site to be Scarified (If clay) YES / NO "SILTY SAND"  
 Clay Seal Required (If bedrock) YES / NO AS PER LEL "GEOTECH REPORT."

- Trench**  
 Distribution Pipe Length \_\_\_\_\_ m  
 Loading Area \_\_\_\_\_ m<sup>2</sup>  
 Type of Chamber \_\_\_\_\_  
 Length of Chamber \_\_\_\_\_ m
- Shallow Buried Trench**  
 Pipe Length \_\_\_\_\_ m
- Filter Media Bed**  
 Stone \_\_\_\_\_ m<sup>2</sup>  
 Extended Base \_\_\_\_\_ m<sup>2</sup>  
 Pipe \_\_\_\_\_ m  
 Weight of Filter Media \_\_\_\_\_ Kg  
 Loading Area \_\_\_\_\_ m
- Dispersal Bed** L = 81 / 400
- BMEC**  Type A  Type B  
 Stone \_\_\_\_\_ m<sup>2</sup>  
 Sand 65.5 m<sup>2</sup> MIN ∴ 68.04 m<sup>2</sup> PROVIDED  
 Pipe SEE "FLOW CALCULATION"  
 Linear Loading \_\_\_\_\_ L/m<sup>2</sup>

- Tank/Treatment Unit/Pump Chamber Replacement ONLY**
- Effluent Filter & Riser ONLY**

Construction Notes:  
 \_\_\_\_\_  
 \_\_\_\_\_  
 \_\_\_\_\_



Do Not Complete  
 Permit # \_\_\_\_\_  
 Revision # \_\_\_\_\_  
 Date \_\_\_\_\_

### Schedule 6 Soil and Water Table Information (Minimum depth of test pit: 2 metres)

Name of Applicant/Agent: MARIE-ANDRÉE DÉCROIX Inspector: \_\_\_\_\_  
 Date: April 19, 2023 Time: \_\_\_\_\_ Date: \_\_\_\_\_ Time: \_\_\_\_\_  
 Applicant/Agent Signature: [Signature] Inspector Signature: \_\_\_\_\_

EG (.76.94)	Soil Description	T	EG (.....)	Soil Description	T
.5m	SILTY SAND ASSUMED HGWT AS PER LRL GEOTECH. REPORT FILE No: 220407 @ BH# 3	Ø @ 20 for SILTY SAND [SB-6]	.5m		
1.0m			1.0m		
1.5m			1.5m		
2.0m			2.0m		

EG (.....)	Soil Description	T	EG (.....)	Soil Description	T
.5m			.5m		
1.0m			1.0m		
1.5m			1.5m		
2.0m			2.0m		

**LEGEND**  
 BR = Bedrock                      HGWT = High ground water table                      EG = Existing grade  
 GWT = Ground water table                      M = metres                      T = percolation rate



Do Not Complete  
 Permit # \_\_\_\_\_  
 Revision # \_\_\_\_\_  
 Date \_\_\_\_\_

Scale: 1Block = \_\_\_\_\_

**Schedule 7  
 Layout Section**

N

SEE PROVIDED  
 "SEPTIC LAYOUT"

○Dug Well ●Drilled Well ▲ Neighbouring Homes ◇Benchmark ---Tile Drainage —Property Line

Elevations (metric only)  
 B.M. \_\_\_\_\_ m  
 B.M.Description \_\_\_\_\_  
 \_\_\_\_\_  
 Exact Location \_\_\_\_\_

Min. of 5 elevations in proposed system area (in X pattern)

X <sub>1</sub> _____	X <sub>2</sub> _____
X <sub>3</sub> _____	X <sub>4</sub> _____
X <sub>5</sub> _____	X <sub>6</sub> (toe) _____
X <sub>7</sub> _____	X <sub>8</sub> _____





Do Not Complete  
 Permit # \_\_\_\_\_  
 Revision # \_\_\_\_\_  
 Date \_\_\_\_\_

### Schedule 8 Fixture unit count

Fixtures	# Existing	+ # Proposed	X	unit count	=	Fixture Count
<b>Bathroom</b>						
Bathroom group (toilet, sink and tub or shower) installed in the <u>same</u> room			X	6	=	
Bathtub with/without overhead shower			X	1.5	=	
Shower stall		4	X	1.5	=	6
Wash basin (SINK) (1½inch trap)		5	X	1.5	=	7.5
Watercloset (TOILET) tank operated		5	X	4	=	20
Bidet / URINAL		3	X	1	=	3
<b>Kitchen</b>						
Dishwasher		1	X	1	=	1
Sink with/without garbage grinder(s), domestic and other small type single, double or 2 single with a common trap		1	X	1.5	=	1.5
<b>Other</b>						
Domestic washing machine		1	X	1.5	=	1.5
Combination sink and laundry tray single or double (Installed on 1½ trap)		1	X	1.5	=	1.5
<b>*Total:</b>						42

\*Insert the TOTAL in section 5 of Schedule 4 (0.Reg 151/13 Table 7.4.9.3)

1. **Sump pumps and floor drains are not to be connected to the sewage system.** Connection of such fixtures to a sewage system may lead to a hydraulic failure of the said system. The above mentioned fixtures should be discharged separately to an approved Class 2 (leaching pit) sewage system.
2. Where laundry waste is not more than 20% of the total daily design sanitary sewage flow, it may discharge to a sewage system (Part 8, OBC, 8.1.3.1(2)).

\_\_\_\_\_  
 Agent/Owner signature

April 19, 2023  
 Date

Do Not Complete  
 Permit # \_\_\_\_\_  
 Revision # \_\_\_\_\_  
 Date \_\_\_\_\_



Ottawa Septic Bureau des systèmes  
 System Office septiques d'Ottawa  
**TYPICAL DRAWING C**  
 BURIED OR RAISED BED - BMEC ELJEN System

# Plan View

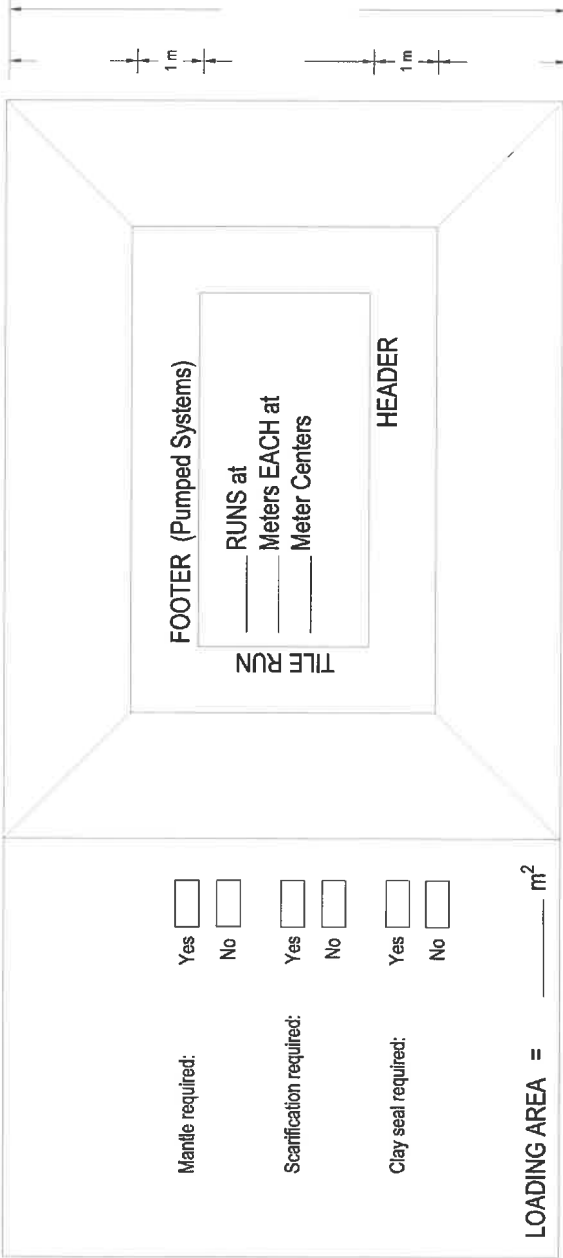

- Mantle required: Yes  No
- Scarification required: Yes  No
- Clay seal required: Yes  No

LOADING AREA = \_\_\_\_\_ m<sup>2</sup>

DRAWING NOT TO SCALE

*SEE RAISED SEPTIC SECTION "*

# Cross-Section Profile

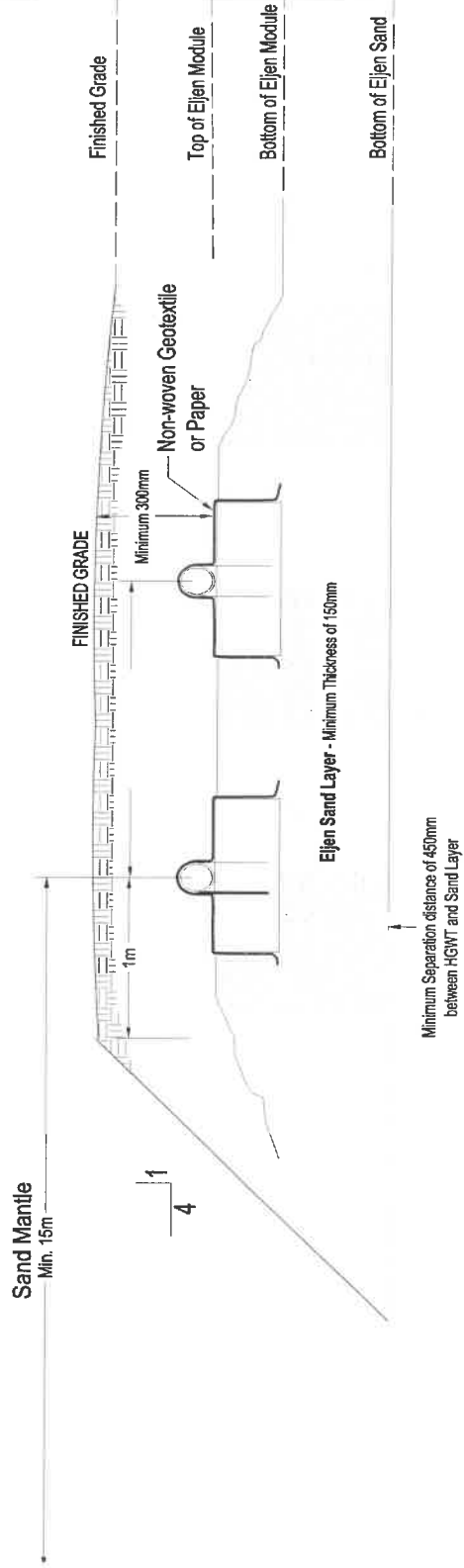

Minimum Separation distance of 450mm between HGWT and Sand Layer

Proposed Installation Grades	Approved Installation Grades	Existing Grade

High Ground Water Table/ Unsuitable Soil/ Bedrock

DRAWING NOT TO SCALE



# LRJ

ENGINEERING | INGÉNIERIE

5430 Canotek Road | Ottawa, ON, K1J 9G2

www.lrl.ca | (613) 842-3434

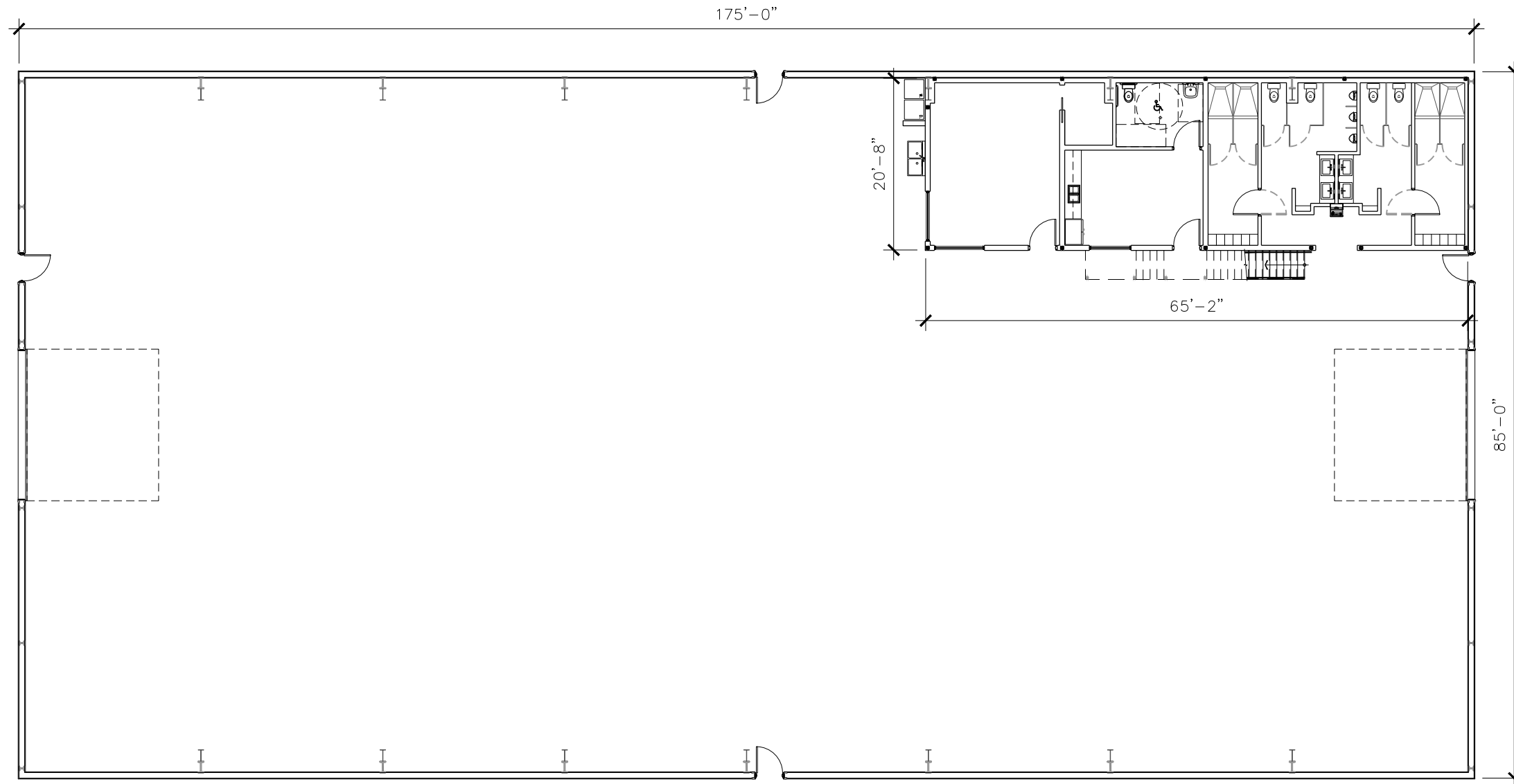

## GROUND FLOOR PLAN

SCALE: 1/16" = 1'-0"



LRJ

ENGINEERING | INGÉNIERIE

5430 Canotek Road | Ottawa, ON, K1J 9G2  
www.lrl.ca | (613) 842-3434

- WAREHOUSE = 2x Loading Bay = 2x150L = 300L.

- OFFICE AREA =  $75L / 9.3m^2 = 1347 sq. ft. = \frac{125.12m^2}{9.3m^2} = 13.46 \times 75L = 1010L$

300L + 1010L = 1310L/D.

↳ Design Flow/Day.

OR  
 $75L / 9.3m^2 / PERSON$

↳ AS PER T.3.1.17 OBC.

OFFICE SPACE  $75L / 9.3m^2$

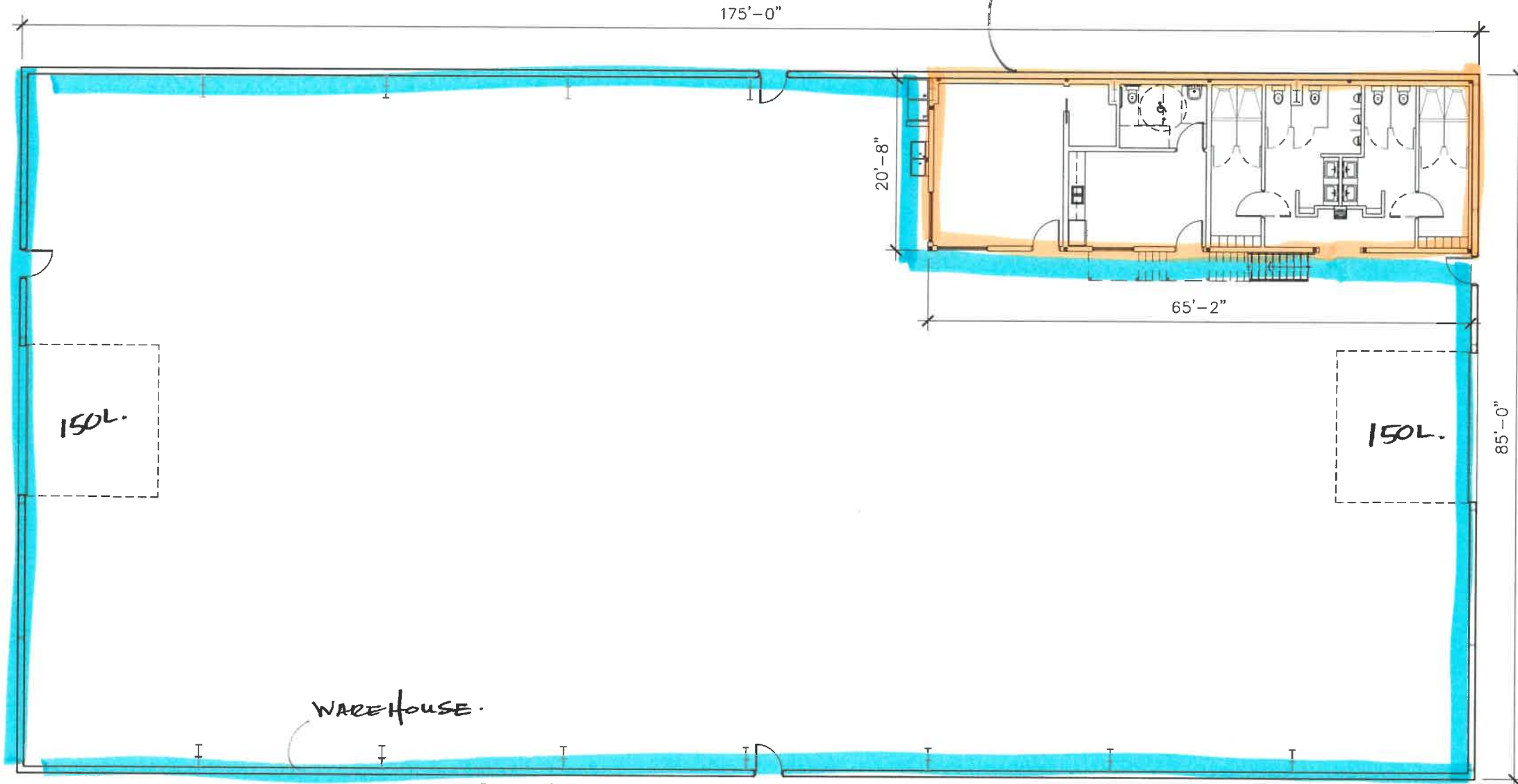

@TEST PIT 24x3"

\* HGWT @ 0.5m

Below Existing  
GRADE [SEE LRL  
REPORT]

GROUND FLOOR PLAN

SCALE: 1/16" = 1'-0"

Silty sand [SB-6]

LOADING AREA.

$$= \frac{QI}{400} = \frac{1310 \times 20}{400}$$

$$= 65.5m^2 \text{ MIN.}$$

$$\text{Provided} = 4.2m \times 16.2m \\ = 68.04m^2$$

ELJEN SYSTEM.

$$\text{↳ } \frac{LD}{95}$$

$$= \frac{1310}{95} = 13.79$$

= 14 MODULES REQ'D.

2 RUNS OF 7 MODULES.

SEPTIC TANK =  $LD \times 3$

$$= 1310 \times 3$$

$$= 3930L \text{ MIN. TANK.}$$

↳ PROPOSED 5,509L TANK.



**LRJ**

ENGINEERING | INGÉNIERIE

## **Geotechnical Investigation**

Proposed Warehouse  
363 Entrepreneur Crescent  
Navan, Ontario

Prepared for:

Entrepreneur Holding Corporation  
363 Entrepreneur Crescent  
Navan, Ontario  
K4B 1T8

LRL File No.: 220487

February 2023



## TABLE OF CONTENTS

<b>1</b>	<b>INTRODUCTION .....</b>	<b>1</b>
<b>2</b>	<b>SITE AND PROJECT DESCRIPTION .....</b>	<b>1</b>
<b>3</b>	<b>PROCEDURE .....</b>	<b>1</b>
<b>4</b>	<b>SUBSURFACE SOIL AND GROUNDWATER CONDITIONS .....</b>	<b>2</b>
4.1	General .....	2
4.2	Fill Material.....	2
4.3	Silty Sand .....	3
4.4	Clayey Silt .....	3
4.5	Silty Clay .....	3
4.6	Inferred Glacial Till.....	3
4.7	Refusal.....	3
4.8	Laboratory Analysis .....	3
4.9	Groundwater Conditions.....	4
<b>5</b>	<b>GEOTECHNICAL CONSIDERATIONS .....</b>	<b>4</b>
5.1	Foundations .....	4
5.2	Shallow Foundation.....	4
5.3	Structural Fill.....	5
5.4	Lateral Earth Pressure.....	5
5.5	Settlement .....	6
5.6	Seismic .....	6
5.7	Liquefaction Potential .....	6
5.8	Frost Protection .....	6
5.9	Foundation Drainage.....	7
5.10	Foundation Walls Backfill (Shallow Foundations).....	7
5.11	Slab-on-grade Construction.....	7
5.12	Corrosion Potential and Cement Type .....	8
5.13	Other Considerations .....	8
<b>6</b>	<b>EXCAVATION AND BACKFILLING REQUIREMENTS .....</b>	<b>8</b>
6.1	Excavation.....	8
6.2	Groundwater Control.....	9



<b>6.3</b>	<b>Pipe Bedding Requirements .....</b>	<b>9</b>
<b>6.4</b>	<b>Trench Backfill .....</b>	<b>10</b>
<b>7</b>	<b>REUSE OF ON-SITE SOILS.....</b>	<b>10</b>
<b>8</b>	<b>RECOMMENDED PAVEMENT STRUCTURE.....</b>	<b>10</b>
<b>8.1</b>	<b>Paved Areas &amp; Subgrade Preparation.....</b>	<b>11</b>
<b>9</b>	<b>INSPECTION SERVICES .....</b>	<b>12</b>
<b>10</b>	<b>REPORT CONDITIONS AND LIMITATIONS.....</b>	<b>12</b>

## LIST OF TABLES

<b>Table 1 – Gradation Analysis Summary.....</b>	<b>3</b>
<b>Table 2 – Summary of Atterberg Limits and Water Contents .....</b>	<b>4</b>
<b>Table 3 – Material and Earth Pressure Properties.....</b>	<b>6</b>
<b>Table 4 – Results of Chemical Analysis.....</b>	<b>8</b>
<b>Table 5 – Recommended Pavement Structure.....</b>	<b>11</b>

## APPENDICES

<b>Appendix A</b>	<b>Site and Borehole Location Plans</b>
<b>Appendix B</b>	<b>Borehole Logs</b>
<b>Appendix C</b>	<b>Symbols and Terms Used in Borehole Logs</b>
<b>Appendix D</b>	<b>Lab Results</b>



## 1 INTRODUCTION

LRL Associates Ltd. (LRL) was retained by Dustin Wilson of Entrepreneur Holding Corporation to perform a geotechnical investigation for a proposed warehouse, to be located at 363 Entrepreneur Crescent, Navan, Ontario.

The purpose of the investigation was to identify the subsurface conditions across the site by the completion of a limited borehole drilling program. Based on the visual and factual information obtained, this report will provide guidelines on the geotechnical engineering aspects of the design of the project, including construction considerations.

This report has been prepared in consideration of the terms and conditions noted above. Should there be any changes in the design features, which may relate to the geotechnical recommendations provided in the report, LRL should be advised in order to review the report recommendations.

## 2 SITE AND PROJECT DESCRIPTION

The site under investigation is civically located at 363 Entrepreneur Crescent, in Navan, Ontario. Currently the site is vacant of any structures, but is currently being used as a storage yard by the adjacent property for construction equipment and vehicles. The approximate location is presented in Figure 1 included in **Appendix A**. The lot is approximately rectangular in shape, having about 35 m of frontage, and a depth of about 80 m. The site is bound by 357 Entrepreneur Crescent to the east, Entrepreneur Crescent to the south, 371 Entrepreneur Crescent to the west, and 5425 Boundary Road to the north. At the time of carrying out the field work, the site was covered by a thin layer of snow. The topography of the site is considered to be relatively flat. Access to the site will come by way of Entrepreneur Crescent.

It is understood that development on this site will consist of construction of a 15,000 ft<sup>2</sup> warehouse, with no basement. The structure will be a pre-engineered building, supported by a conventional shallow foundation. The building will be serviced with a well and septic system.

## 3 PROCEDURE

The fieldwork for this investigation was carried out on November 17, 2022. Prior to the fieldwork, the site was cleared for the presence of any underground services and utilities. A total of four (4) boreholes, labelled BH1 through BH4, were drilled across the site to get a general understanding of the site's soil conditions. The approximate locations of the boreholes are shown in Figure 2 included in **Appendix A**.

The boreholes were advanced using a track mount CME 75 drill rig equipped with 200 mm diameter continuous flight hollow stem auger supplied and operated by CCC Geotechnical and Environmental Drilling Ltd. A "two man" crew experienced with geotechnical drilling operated the drill rig and equipment.

Sampling of the overburden materials encountered in the boreholes was carried out at regular depth intervals using a 50.8 mm diameter drive open conventional spoon sampler in conjunction with standard penetration testing (SPT) "N" values. The SPT were conducted following the method **ASTM D1586** and the results of SPT, in terms of the





number of blows per 0.3 m of split-spoon sampler penetration after first 0.15 m designated as “N” value.

In-situ field vane shear testing using a tapered vane was carried out in the soft to very soft cohesive soils. The undrained shear strength values were calculated following **ASTM D 2573**.

The boreholes were augered and sampled to a depth of 7.00 m below ground surface (bgs). A Dynamic Cone Penetration (DCP) test was carried out in BH2 until refusal (24.50 m bgs) to determine the overburden thickness. Upon completion, the boreholes were backfilled using the overburden cuttings.

The fieldwork was supervised throughout by a member of our engineering staff who oversaw the drilling activities, cared for the samples obtained and logged the subsurface conditions encountered within each of the boreholes. All soil samples collected from the boreholes were placed and sealed in plastic bags to prevent moisture loss. The recovered soil samples collected from the boreholes were classified based on visual examination of the materials recovered and the results of the in-situ testing.

Furthermore, all boreholes were located using a Garmin Etrex Legend GPS (Global Positioning System) receiver using NAD 83 datum (North American Datum). An elevation survey was carried out onsite to determine the borehole locations' elevation. A Temporary Benchmark (TBM) was assigned using the top of the culvert located at the southwest of driveway entrance, and given an elevation of 100.00 m. Ground surface elevations of the boring locations are shown on their respective borehole logs, attached in **Appendix B**.

## **4 SUBSURFACE SOIL AND GROUNDWATER CONDITIONS**

### **4.1 General**

A review of local surficial geology maps provided by the Department of Energy, Mines and Resources Canada suggest that this site consists of a “Champlain Sea Deposits” consisting of blue-grey clay, silt, and silty clay.

The subsurface conditions encountered in the boreholes were classified based on visual and tactile examination of the materials recovered from the boreholes and the results of in-situ laboratory testing. The soil descriptions presented in this report are based on commonly accepted methods of classification and identification employed in geotechnical practice. Classification and identification of soil were conducted according to the procedure **ASTM D2487** and judgement, and LRL does not guarantee descriptions as exact, but infers accuracy to the extent that is common in current geotechnical practice.

The subsurface soil conditions encountered at the boreholes are given in their respective logs presented in **Appendix B**. A greater explanation of the information presented in the borehole logs can be found in **Appendix C** of this report. These logs indicate the subsurface conditions encountered at a specific test location only. Boundaries between zones on the logs are often not distinct, but are rather transitional and have been interpreted as such.

### **4.2 Fill Material**

Fill material consisting of a crushed stone granular material was encountered at the surface of all boring locations, and extended to depths ranging between 0.60 and 1.07 m bgs. The recorded SPT “N” values of this deposit varied from 30 to 36, indicating the deposit is dense. The natural moisture contents were found to be 9 and 11%.



### 4.3 Silty Sand

Underlying the fill material at all boring locations, a layer of brown silty sand was encountered and extended to a depth of 1.45 m bgs. The recorded SPT “N” values of this deposit varied from 14 to 19, indicating the deposit is compact. The natural moisture contents were found to be 22 and 24%.

### 4.4 Clayey Silt

Below the silty sand in all boring locations, a layer of clayey silty was encountered and extended to a depth of 4.12 m bgs. This material contained trace sand, grey and wet. The SPT “N” values were found to range between 0 (weight of hammer (WH)) and 4, indicating the material is soft to very soft. The natural moisture contents were determined to range between 37 and 87%.

### 4.5 Silty Clay

Underlying the clayey silt in all boring locations, a layer of silty clay was encountered and extended to the end of sampling at a depth of 7.00 m bgs. This was found to be grey, and wet. The SPT “N” values of this layer were WH, indicating the material is very soft. The natural moisture contents were determined to be 76 and 90%.

### 4.6 Inferred Glacial Till

Inferred glacial till was encountered in BH2 by way of the DCP test. This was found to be in a compact to very dense state of packing.

### 4.7 Refusal

Refusal using the DCP test was encountered in BH2 at a depth of 24.50 m bgs. This was encountered over a large boulder within the till material or possible bedrock.

### 4.8 Laboratory Analysis

Two (2) soil samples were collected for laboratory gradation analyses. The gradation analyses comprised of sieve and hydrometer were conducted following the procedure **ASTM D422**. Details of laboratory analyses are reflected in **Table 1**.

**Table 1: Gradation Analysis Summary**

Sample Location	Depth (m)	Percent for Each Soil Gradation					Estimated Hydraulic Conductivity K (m/s)
		Sand			Silt (%)	Clay (%)	
		Coarse (%)	Medium (%)	Fine (%)			
BH1	1.52 – 2.13	0.4	0.8	4.1	59.3	35.4	$5 \times 10^{-8}$
BH2	6.10 – 6.71	0.0	0.0	0.6	31.0	68.4	$5 \times 10^{-8}$

Atterberg limits and moisture contents were conducted on two (2) split spoon soil samples. A summary of these values are provided below in **Table 2**.



**Table 2: Summary of Atterberg Limits and Water Contents**

Sample Location	Parameter					
	Depth (m)	Liquid Limit (%)	Plastic Limit (%)	Plasticity Index (%)	Water Content (%)	USCS Group Symbol
BH3	4.57 – 5.18	61	23	38	90	CH
BH4	1.52 – 2.13	67	25	42	77	CH

The laboratory reports can be found in **Appendix D** of this report.

#### 4.9 Groundwater Conditions

A piezometer was installed in BH3 to measure the static groundwater level. The piezometer consisted of a 19 mm diameter PVC pipe with a slotted bottom to allow for groundwater infiltration, backfilled with silica sand, and sealed with bentonite. The water was measured on December 6, 2022 and found to be at 0.5 m bgs. This is expected to be perched water, and not the true groundwater level of the site.

It should be noted that groundwater levels could fluctuate with seasonal weather conditions, (i.e.: rainfall, droughts, spring thawing) and due to construction activities at or in the vicinity of the site.

### 5 GEOTECHNICAL CONSIDERATIONS

This section of the report provides general geotechnical recommendations for the design aspect of the project based on our interpretation of the information gathered from the boreholes performed at this site and from the project requirements.

This section will detail the specific requirements and limitations with regard to allowable foundation bearing pressure and depth, grade raise and size of the footings.

#### 5.1 Foundations

Based on the subsurface soil conditions established at this site, it is expected that the footings for the proposed warehouse will be founded below the frost penetration depth, overlying the native silty sand and/or clayey silt. Therefore, all fill material including incompetent native soil should be removed from the proposed footprint down to the required founding depth.

#### 5.2 Shallow Foundation

Conventional strip and column footings founded over the undisturbed native silty sand and/or clayey silt may be designed using a maximum allowable bearing pressure of **50 kPa** for serviceability limit state (**SLS**) and **75 kPa** for ultimate limit state (**ULS**) factored bearing resistance. The factored ULS value includes the geotechnical resistance factor of 0.5. This bearing capacity limits the allowable earth grade raise to 1.0 m and a strip footing maximum width of 2.0 m, and a pad footing maximum width of 4.0 m on any side. If a greater earth fill grade raise or larger footings are required, the bearing capacity would need to be reduced.

In-situ field testing is required to check the strength and stability of the footings subgrade. Any incompetent subgrade areas as identified from in-situ testing must be sub-excavated



and backfilled with approved structural fill. Similarly, any soft or wet areas should also be sub-excavated and backfilled with approved structural fill only. Prior to placing any approved structural fill, the subgrade should be inspected and approved by geotechnical engineer or qualified geotechnical personnel. The bearing pressure is contingent on the water level being 0.3 m below the underside footing elevation in order to have a stable and dry subgrade during construction.

Prior to pouring footings concrete, the subgrade should be inspected and approved by a geotechnical engineer or a representative of geotechnical engineer. If the footings are founded on clayey silt, it may be prudent to place a 50 mm thick mudslab consisting of a lean concrete mix in order to protect the subgrade prior to placement of the footing formwork. This can be discussed further at the time of the excavation for the foundation.

### 5.3 Structural Fill

For foundations set over undisturbed native soil and where excavation below the underside of the footings is performed in order to reach a suitable founding stratum, consideration should also be given to support the footings on structural fill. The structural fill should be placed over undisturbed native soils in layers not exceeding 300 mm and compacted to 98% of its Standard Proctor Maximum Dry Density (SPMDD) within  $\pm 2\%$  of its optimum moisture content. In order to allow the spread of load beneath the footings and to prevent undermining during construction, the structural fill should extend minimum 1.0 m beyond the outside edges of the footings and then outward and downward at 1 horizontal to 1 vertical profile (or flatter) over a distance equal to the depth of the structural fill below the footing. Furthermore, the structural fill must be tested to ensure that the specified compaction level is achieved.

### 5.4 Lateral Earth Pressure

The following equation should be used to estimate the intensity of the lateral earth pressure against any earth retaining structure/foundation walls.

$$P = K (\gamma h + q)$$

Where;

P = Earth pressure at depth h;

K = Appropriate coefficient of earth pressure;

$\gamma$  = Unit weight of compacted backfill, adjacent to the wall;

h = Depth (below adjacent to the highest grade) at which P is calculated;

q = Intensity of any surcharge distributed uniformly over the backfill surface (usually surcharge from traffic, equipment or soil stockpiled and typically considered 10 kPa).

The coefficient of earth pressure at rest ( $K_0$ ) should be used in the calculation of the earth pressure on the storm water manhole/basement walls, which are expected to be rather rigid and not to deflect.

The above expression assumes that perimeter drainage system prevents the build-up of any hydrostatic pressure behind the foundation wall.

**Table 3** below provides various material types and their respective earth pressure properties.



**Table 3: Material and Earth Pressure Properties**

Type of Material	Bulk Density (kN/m <sup>3</sup> )	Friction Angle (Φ)	Pressure Coefficient		
			At Rest (K <sub>0</sub> )	Active (K <sub>A</sub> )	Passive (K <sub>P</sub> )
Granular A	23.0	34	0.44	0.28	3.53
Granular B Type I	20.0	31	0.49	0.32	3.12
Granular B Type II	23.0	32	0.47	0.31	3.25
Silty Sand	17.5	30	0.50	0.33	3.00
Clayey Silt to Silty Clay	18.5	25	0.52	0.41	2.46

### 5.5 Settlement

The estimated total settlement of the shallow foundations, designed using the recommended serviceability limit state capacity value, as well as other recommendations given above, will be less than 25 mm. The differential settlement between adjacent column footings is anticipated to be 15 mm or less.

### 5.6 Seismic

Based on the information of this geotechnical investigation and in accordance with the Ontario Building Code 2015 (Table 4.1.8.4.A.) and Canadian Foundation Engineering Manual (4<sup>th</sup> edition), the site can be classified for Seismic Site Response Site Class D. This classification is based on the  $N_{60,average}$  exceeding 15.

The above classifications were recommended based on conventional method exercised for Site Classification for Seismic Site Response and in accordance with the generally accepted geotechnical engineering practice.

### 5.7 Liquefaction Potential

As recommended in Canadian Foundation Engineering Manual 4<sup>th</sup> edition (*Bray et al. 2004*), the following criteria can be used to determine liquefaction susceptibility of fine grained soils.

- $w/w_L \geq 0.85$  and  $I_p \leq 12$ : Susceptible to liquefaction or cyclic mobility
- $w/w_L \geq 0.8$  and  $12 \leq I_p \leq 20$ : Moderately susceptible to liquefaction or cyclic mobility
- $w/w_L < 0.8$  and  $I_p \leq 20$ : No liquefaction or cyclic mobility, but may undergo significant deformations if cyclic shear stress > static undrained shear strength.

Based on the above criteria, liquefaction is not a concern for this site.

### 5.8 Frost Protection

All exterior footings for any heated structure exposed to frost conditions should have a minimum of 1.5 m of earth cover. Footings for any unheated structures, signage or lighting, and where snow will be cleared, 1.8 m of earth cover is required. Alternatively, the required frost protection could be provided using a combination of earth cover and extruded polystyrene insulation. Detailed guidelines for footing insulation frost protection can be provided upon request.



In the event that foundations are to be constructed during winter months, the foundation soils are required to be protected from freezing temperatures using suitable construction techniques. The base of all excavations should be insulated from freezing temperatures immediately upon exposure, until heat can be supplied to the building interior and the footings have sufficient soil cover to prevent freezing of the subgrade soils.

## 5.9 Foundation Drainage

Permanent perimeter drainage is only required for buildings where basements or whenever any open spaces located below the finish ground are being considered. It is our understanding that no basement construction is included as part of this development and hence no perimeter drainage is required. However, in order to minimize ponding of water adjacent to the foundation walls, roof water should be controlled by a roof drainage system that directs water away from the building to prevent ponding of water adjacent to the foundation wall.

## 5.10 Foundation Walls Backfill (Shallow Foundations)

To prevent possible foundation frost jacking and lateral loading, the backfill material against any foundation walls, grade beams, isolated walls, or piers should consist of free draining, non-frost susceptible material such as sand or sand and gravel meeting OPSS Granular B Type II or I, or a Select Subgrade Material (SSM).

The foundation wall backfill should be compacted to minimum 95% of its SPMDD using light compaction equipment, where no loads will be set over top. The compaction shall be increased to 98% of its SPMDD under walkways, slabs or paved areas close to the foundation or retaining walls. Backfilling against foundation walls should be carried out on both sides of the wall at the same time where applicable.

## 5.11 Slab-on-grade Construction

Concrete slab-on-grade should rest over compacted, free draining and well graded structural fill only. Therefore, all fill, or otherwise deleterious material shall be removed from the proposed building's footprint. The exposed undisturbed native subgrade should then be inspected and approved by a qualified geotechnical personnel.

Any underfloor fill needed to raise the general floor grade shall consist of OPSS Granular B Type II or I or SSM material or an approved equivalent, compacted to 95% of its SPMDD. The final lift shall be compacted to 98% of its SPMDD. A minimum 200 mm Granular A layer meeting the **OPSS 1010** shall be placed underneath the slab and compacted to 98% of its SPMDD.

It is also recommended that the area of extensive exterior slab-on-grade (sidewalks, ramp etc.) shall be constructed using Granular A base of thickness 150 mm with incorporating subdrain facilities. The modulus of subgrade reaction (ks) for the design of the slabs set over competent native soil/structural fill is **22 MPa/m**.

In order to further minimize and control cracking, the floor slab shall be provided with wire or fibre mesh reinforcement and construction or control joints. The construction or control joints should be spaced equal distance in both directions and should not exceed 4.5 m. The wire or fibre mesh reinforcement shall be carried out through the joints.

If any areas of the proposed building area are to remain unheated during the winter period, thermal protection of the slab on grade may be required. The "Guide for Concrete Floor and Slab Construction", **ACI 302.1R-04** is recommended to follow for the design and



construction of vapour retarders below the floor slab. Further details on the insulation requirements could be provided, if necessary.

### 5.12 Corrosion Potential and Cement Type

A soil sample was submitted to Paracel Laboratories Ltd. for chemical testing. The following **Table 4** below summarizes the results.

**Table 4: Results of Chemical Analysis**

Sample Location	Depth (m)	pH	Sulphate (µg/g)	Chloride (µg/g)	Resistivity (Ohm.cm)
BH4	1.5 – 2.1	7.44	78	101	2,120.0

The above results revealed a measured sulphate concentration of 78 µg/g. Based on the CAN/CSA-A23.1 standards (Concrete Materials and Methods of Concrete Construction), a sulphate concentration of less than 1000 µg/g falls within the negligible category for sulphate attack on buried concrete. The test results from soil sample is below the noted threshold. As such, buried concrete for footings and foundations walls will not require any special additive to resist sulphate attack and the use of normal Portland cement is acceptable.

The pH, resistivity and chloride concentration provide an indication of the degree of corrosiveness of the sub-surface environment. The soil resistivity was measured to be 2,120.0 ohm.cm, which falls between the “highly corrosive” range for soil resistivity.

### 5.13 Other Considerations

As noted above in **Section 4.7**, the Atterberg Limits results indicate the moisture content is higher than the liquid limit. This indicates that a loss of moisture from the material could result in shrinkage of the soil and subsequent excessive settlements may occur. To help maintain the groundwater level, it is recommended to install clay dykes within any service trench, downstream from each of the manholes. These dykes should extend from the base of the service trench to the subgrade level, having minimum width of 1.0 m.

In addition to clay dykes, any trees planted onsite should respect the City of Ottawa “Tree Planting in Sensitive Marine Clay Soils – 2017 Guidelines”.

## 6 EXCAVATION AND BACKFILLING REQUIREMENTS

### 6.1 Excavation

It is anticipated that the depth of excavation for the building will not be extended below 1.5 - 1.8 m bgs. Most of the excavation being carried out will be through native silty sand and clayey silt. Excavation must be carried out in accordance with Occupational Health and Safety Act and Regulations for construction Projects.

According to the Ontario’s Occupational Health and Safety Act (OHSA), O. Reg. 213/91 and its amendments, the surficial overburden expected to be excavated into at this site can be classified as Type 3. Therefore, shallow temporary excavations can be cut at 1 horizontal to 1 vertical (1H: 1V) for a fully drained excavation starting at the base of the excavation and as per requirements of the OHSA regulations.



Any excavated material stockpiled near an excavation or trench should be stored at a distance equal to or greater than the depth of the excavation/trench and construction equipment, traffic should be limited near open excavation.

## 6.2 Groundwater Control

Based on the subsurface conditions encountered at this site, groundwater seepage or infiltration from the native soils into the shallow temporary excavations during construction is expected. However, it is anticipated that pumping from open sumps should be sufficient to control groundwater inflow. Any groundwater seepage or infiltration entering the excavation should be removed from the excavation by pumping from sumps within the excavations. Surface water runoff into the excavation should be minimized and diverted away from the excavation if possible.

A permit to take water (PTTW) is required from Ministry of Environment and Climate Change (MOECC), Ontario Reg. 387/04, if more than 400,000 litres per day of groundwater will be pumped during a construction period less than 30 days. Registration in the Environmental Activity and Sector Registry (EASR) is required when the takings of ground water and storm water for the purpose of dewatering construction projects range between 50,000 and 400,000 litres per day.

Based on the field investigation through localized borings, it is anticipated that pumping of groundwater will not exceed 50,000 litres per day. As such, no PTTW nor registration in the EASR is anticipated to be required for the construction of the proposed warehouse at this site.

## 6.3 Pipe Bedding Requirements

It is anticipated that any underground services required as part of this project will be founded over clayey silt. Alternately, underground services may be founded over properly prepared and approved structural fill, where excavation below the invert is required. Consequently all organic material should be removed down to a suitable bearing layer. Any sub-excavation of disturbed soil should be removed and replaced with a Granular B Type II or I or approved equivalent, laid in loose lifts of thickness not exceeding 300 mm and compacted to 95% of its SPMDD. Bedding, thickness of cover material and compaction requirements for any pipes should conform to the manufacturers design requirements and to the detailed installations outlined in the Ontario Provincial Standard Specifications (OPSS) and any applicable standards or requirements.

If services are required to be founded below the groundwater table the native materials may be sensitive to disturbances and may also be susceptible to piping and scouring from water pressure at the base of the excavation. Therefore, special precautions should be taken in these areas to stabilize and confine the base of the excavation such as using recompression (thicker bedding) and/or dewatering methods (pre-pumping). In order to properly compact the bedding, the water table should be kept at least 300 mm below the base of the excavation at all time during the installation of any sewers and structures.

As an alternative to Granular A bedding and only where wet conditions are encountered, the use of "clear stone" bedding, such as 19 mm clear stone, **OPSS 1004**, may be considered only in conjunction with a suitable geotextile filter (such as terrafix 270R or approved equivalent). Without proper filtering, there may be entry of fines from native soils and trench backfill into the bedding, which could result in loss of support to the pipes and possible surface settlements. The sub-bedding, bedding and cover materials should be





compacted in maximum 200 mm thick lifts to at least 95% of its SPMDD within  $\pm 2\%$  of its optimum moisture content using suitable vibratory compaction equipment.

#### **6.4 Trench Backfill**

All service trenches should be backfilled using compactable material, free of organics, debris and large cobbles or boulders. Acceptable native materials (if encountered and where possible) should be used as backfill between the roadway subgrade level and the depth of seasonal frost penetrations (i.e. 1.8 m below finished grade) in order to reduce the potential for differential frost heaving between the new excavated trench and the adjacent section of roadway. Where native backfill is used, it should match the native materials exposed on the trench walls. Backfill below the zone of seasonal frost penetration could consist of either acceptable native material or imported granular material conforming to OPSS Granular B Type II or I. Any boulders larger than 150 mm in size should not be used as trench backfill.

To minimize future settlement of the backfill and achieve an acceptable subgrade for the roadway, the trench should be compacted in maximum 300 mm thick lifts to at least 95% of its SPMDD. The specified density may be reduced where the trench backfill is not located within or in close proximity to existing roadways or any other structures.

For trenches carried out in existing paved areas, transitions should be constructed to ensure that proper compaction is achieved between any new pavement structure and the existing pavement structure to minimize potential future differential settlement between the existing and new pavement structure. The transition should start at the subgrade level and extend to the underside of the asphaltic concrete level (if any) at a 1 horizontal to 1 vertical slope. This is especially important where trench boxes are used and where no side slopes are provided to the excavation. Where asphaltic concrete is present, it should be cut back to a minimum of 150 mm from the edge of the excavation to allow for proper compaction between the new and existing pavement structures.

### **7 REUSE OF ON-SITE SOILS**

The existing surficial overburden soils consist mostly of silty sand to clayey silt. These materials are considered to be frost susceptible and should not be used as backfill material directly against foundation walls or underneath unheated concrete slabs. However, these could be reused as general backfill material (service trenches, general landscaping/backfilling) if it can be compacted according to the specifications outlined herein at the time of construction and found free from any waste, organics and debris. Any imported material shall conform to OPSS Granular B – Type II or I, SSM or approved equivalent.

It should be noted that the adequacy of any material for reuse as backfill will depend on its water content at the time of its use and on the weather conditions prevailing prior to and during that time. Therefore, all excavated materials to be reused shall be stockpiled in a manner that will prevent any significant changes in their moisture content, especially during wet conditions. Any excavated materials proposed for reuse should be stockpiled in a manner to promote drying and should be inspected and approved for reuse by a geotechnical engineer.

### **8 RECOMMENDED PAVEMENT STRUCTURE**

It is anticipated that the subgrade soils for the new access lanes parking areas will consist mostly of silty sand. The construction will be acceptable over the undisturbed native



material once all organic material, or otherwise deleterious material are removed from the subgrade area. Furthermore, the subgrade must be compacted using a suitable heavy duty compacting equipment and approved by a geotechnical engineer prior to placing any granular base material.

The following **Table 5** presents the recommended pavement structures to be constructed over a stable subgrade along the proposed parking areas and access lanes as part of this project.

**Table 5: Recommended Pavement Structure**

Course	Material	Thickness (mm)	
		Light Duty Parking Area (mm)	Heavy Duty Parking Area (Access Roads, Fire Routes and Trucks) (mm)
Surface	HL3/SP12.5 A/C	50	40
Binder	HL8/SP19.0 A/C	-	50
Base course	Granular A	150	150
Sub base	Granular B Type II	350	450
Total:		550	690

Performance Graded Asphaltic Cement (PGAC) **58-34** is recommended for this project.

The base and subbase granular materials shall conform to **OPSS 1010** material specifications. Any proposed materials shall be tested and approved by a geotechnical engineer prior to delivery to the site and shall be compacted to 98% of its SPMD. Asphaltic concrete shall conform to **OPSS 1150** and be placed and compacted to at least 93% of the Marshall Density. The mix and its constituents shall be reviewed, tested and approved by a geotechnical engineer prior to delivery to the site.

### 8.1 Paved Areas & Subgrade Preparation

The access lanes and parking areas shall be stripped of vegetation, debris and other obvious objectionable fill material. Following the backfilling and satisfactory compaction of any underground service trenches up to the subgrade level, the subgrade shall be shaped, crowned and proof-rolled. A loaded Tandem axle, dual wheel dump truck or approved equivalent heavy duty smooth drum roller shall be used for proof-rolling. Any resulting loose/soft areas should be sub-excavated down to an adequate bearing layer and replaced with approved backfill.

The preparation of subgrade shall be scheduled and carried out in manner so that a protective cover of overlying granular material (if required) is placed as quickly as possible in order to avoid unnecessary circulation by heavy equipment, except on unexcavated or protected surfaces. Frost protection of the surface shall be implemented if works are carried out during the winter season.

The performance of the pavement structure is highly dependent on the subsurface groundwater conditions and maintaining the subgrade and pavement structure in a dry condition. The surface of the pavement should be properly graded to direct runoff water towards suitable drainage features. It is recommended that the lateral extent of the



subbase and base layers not be terminated vertically immediately behind the curb/edge of pavement line but be extended beyond the curb.

## **9 INSPECTION SERVICES**

The engagement of the services of the geotechnical consultant during construction is recommended to confirm that the subsurface conditions throughout the proposed site do not materially differ from those given in the report and that the construction activities do not adversely affect the intent of the design.

All footing areas and any structural fill areas for the proposed structures should be inspected by LRL to ensure that a suitable subgrade has been reached and properly prepared. The placing and compaction of any granular materials beneath the foundations and slab-on-grade should be inspected to ensure that the materials used conform to the grading and compaction specifications.

The subgrade for the pavement areas and underground services should be inspected and approved by geotechnical personnel. In-situ density testing should be carried out on the pavement granular materials, pipe bedding and backfill to ensure the materials meet the specifications for required compaction.

If footings are to be constructed during winter season, the footing subgrade should be protected from freezing temperatures using suitable construction techniques.

## **10 REPORT CONDITIONS AND LIMITATIONS**

It is stressed that the information presented in this report is provided for the guidance of the designers and is intended for this project only. The use of this report as a construction document or its use by a third party beyond the client specifically listed in the report is neither intended nor authorized by LRL Associates Ltd. Contractors bidding on or undertaking the works should examine the factual results of the investigation, satisfy themselves as to the adequacy of the information for construction, and make their own interpretation of the factual data as it affects their construction techniques, schedule, safety and equipment capabilities.

The professional services for this project include only the geotechnical aspects of the subsurface conditions at this site. The presence or implications of possible contamination resulting from previous uses or activities at this site or adjacent properties, and/or resulting from the introduction onto the site of materials from off-site sources are outside the terms of reference for this report.

The recommendations provided in this report are based on subsurface data obtained at the specific boring locations only. Boundaries between zones presented on the borehole are often not distinct but transitional and were interpreted. Experience indicates that the subsurface soil and groundwater conditions can vary significantly between and beyond the test locations. For this reason, the recommendations given in this report are subject to a field verification of the subsurface soil conditions at the time of construction.

The recommendations are applicable only to the project described in this report. Any changes to the project will require a review by LRL Associates Ltd., to ensure compatibility with the recommendations contained in this project.



We trust this report provides sufficient information for your present purposes. If you have any questions concerning this report or if we may be of further services to you, please do not hesitate to contact the undersigned.

Yours truly,  
LRL Associates Ltd.

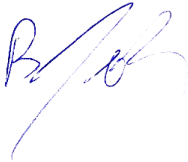

**Brad Johnson, P.Eng.**  
**Geotechnical Engineer**

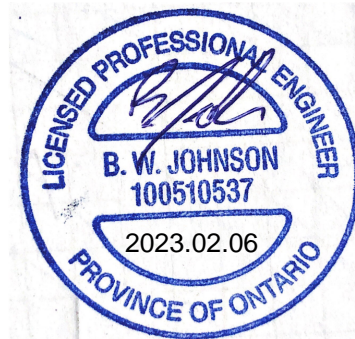

W:\FILES 2022\220487\05 Geotechnical\01 Investigation\05 Reports\220487 -Geotechnical Investigation\_Proposed Warehouse\_363 Entrepreneur Cres\_Navan.docx



**APPENDIX A**  
**Site and Borehole Location Plan**



**LRJ**

ENGINEERING | INGÉNIÉRIE

5430 Canotek Road | Ottawa, ON, K1J 9G2  
www.lri.ca | (613) 842-3434

PROJECT

GEOTECHNICAL INVESTIGATION  
PROPOSED WAREHOUSE DEVELOPMENT  
363 ENTREPRENEUR CRESCENT  
VARS, ONTARIO

DRAWING TITLE

SITE LOCATION  
SOURCE: GEOTTAWA

CLIENT

ENTREPRENEUR HOLDING CORPORATION

DATE

NOVEMBER 2022

PROJECT

220487

**FIGURE 1**

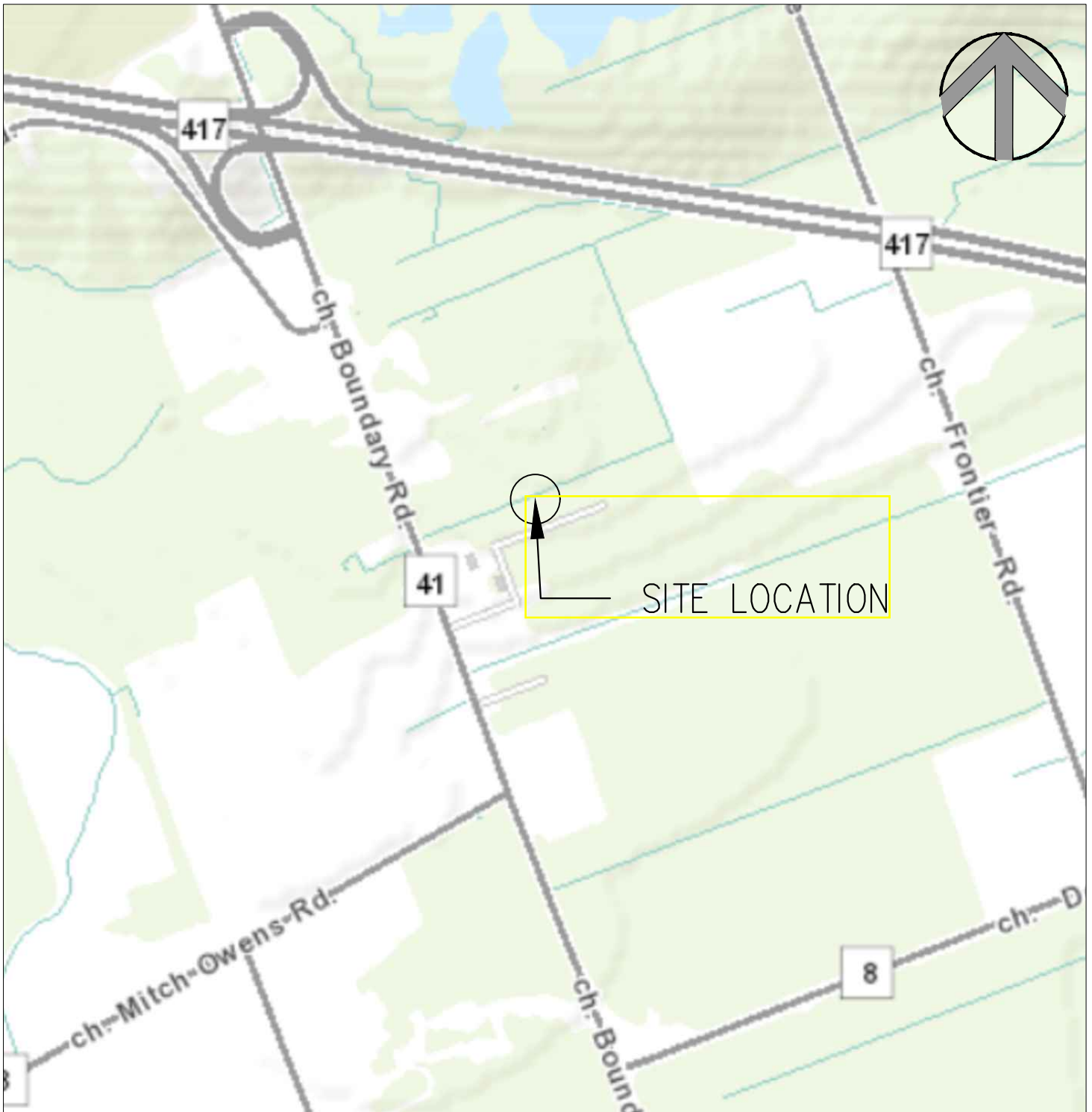



**LRJ**

ENGINEERING | INGÉNIÉRIE

5430 Canotek Road | Ottawa, ON, K1J 9G2  
www.lri.ca | (613) 842-3434

PROJECT

GEOTECHNICAL INVESTIGATION  
PROPOSED WAREHOUSE DEVELOPMENT  
363 ENTREPRENEUR CRESCENT  
VARS, ONTARIO

DRAWING TITLE

BOREHOLE LOCATION  
SOURCE: GOOGLE AERIAL VIEW

CLIENT

ENTREPRENEUR HOLDING CORPORATION

DATE

NOVEMBER 2022

PROJECT

220487

**FIGURE 2**



**APPENDIX B**  
**Borehole Logs**





**Project No.:** 220487  
**Client:** Entrepreneur Holding Corp.  
**Date:** November 17, 2022

**Borehole Log: BH1**  
**Project:** Proposed Warehouse  
**Location:** 363 Entrepreneur Cres. Vars ON  
**Field Personnel:** BJ

**Driller:** CCC Geotech and Enviro Drilling

**Drilling Equipment:** Track Mount CME 75

**Drilling Method:** Hollow Stew Auger

SUBSURFACE PROFILE		SAMPLE DATA				Shear Strength (kPa)	Water Content (%)	Monitoring Well Details	
Depth ft / m	Soil Description	Elev./Depth (m)	Type	Sample Number	N or RQD	Recovery (%)	SPT N Value (Blows/0.3 m)		Liquid Limit (%)
							50 150		25 50 75
0	Ground Surface	100.28							
0	<b>FILL MATERIAL</b> crushed stone, grey, moist, dense.	0.00							
1				SS1	34	42	34	9	
2									
3		99.22							
4	<b>SILTY SAND</b> brown, moist, compact.	1.07		SS2	19	58	19		
5		98.83							
6	<b>CLAYEY SILT</b> trace sand, grey, firm to very soft, wet.	1.45		SS3	4	50	4	37	
7									
8				SS4	WH	100	0		
9									
10				SS5	WH	100	0	87	
11									
12									
13		96.16							
14	<b>SILTY CLAY</b> grey, very soft, wet.	4.12							
15				SS6	WH	100	0		
16									
17									
18							24		
19							24		
20									
21				SS7	WH	100	0	76	
22							24		
23		93.28					24		
24	End of Borehole	7.00							

**Easting:** 465773 m      **Northing:** 5020883 m  
**Site Datum:** TBM - Top of Culvert located at Southwest of Driveway entrance. (100.00 m)  
**Groundsurface Elevation:** 100.285 m      **Top of Riser Elev.:** NA  
**Hole Diameter:** 200 mm      **Monitoring Well Diameter:** N/A

**NOTES:**



**Project No.:** 220487  
**Client:** Entrepreneur Holding Corp.  
**Date:** November 17, 2022

**Borehole Log: BH2**  
**Project:** Proposed Warehouse  
**Location:** 363 Entrepreneur Cres. Vars ON  
**Field Personnel:** BJ

**Driller:** CCC Geotech and Enviro Drilling

**Drilling Equipment:** Track Mount CME 75

**Drilling Method:** Hollow Stew Auger

SUBSURFACE PROFILE		SAMPLE DATA					Shear Strength (kPa)	Water Content (%)	Monitoring Well Details				
Depth	Soil Description	Elev./Depth (m)	Type	Sample Number	N or RQD	Recovery (%)	50	150		25	50	75	
							SPT N Value (Blows/0.3 m)			Liquid Limit (%)			
							20	40	60	80	25	50	75
0	Ground Surface	100.17											
0	<b>FILL MATERIAL</b> crushed stone, grey, moist, dense.	0.00		SS1	30	42							
1							30						
2	<b>SILTY SAND</b> brown, moist, compact.	99.57 0.60		SS2	15	50						22	
3							15						
4													
5	<b>CLAYEY SILT</b> trace sand, grey, firm to very soft, wet.	98.72 1.45		SS3	1	50							
6							1						
7													
8				SS4	WH	58						65	
9							0						
10				SS5	WH	75							
11							0						
12													
13													
14	<b>SILTY CLAY</b> grey, very soft, wet.	96.05 4.12											
15							20						
16				SS6	WH	100							
17							30						
18													
19							24						
							30						

**Easting:** 465762 m      **Northing:** 5020885 m  
**Site Datum:** TBM - Top of Culvert located at Southwest of Driveway entrance. (100.00 m)  
**Groundsurface Elevation:** 100.165 m      **Top of Riser Elev.:** NA  
**Hole Diameter:** 200 mm      **Monitoring Well Diameter:** N/A

**NOTES:**



**Project No.:** 220487  
**Client:** Entrepreneur Holding Corp.  
**Date:** November 17, 2022

**Borehole Log (continued): BH2**

**Project:** Proposed Warehouse  
**Location:** 363 Entrepreneur Cres. Vars ON  
**Field Personnel:** BJ

**Driller:** CCC Geotech and Enviro Drilling

**Drilling Equipment:** Track Mount CME 75

**Drilling Method:** Hollow Stew Auger

SUBSURFACE PROFILE		SAMPLE DATA					Shear Strength (kPa)	Water Content (%)	Monitoring Well Details
Depth	Soil Description	Elev./Depth (m)	Type	Sample Number	N or RQD	Recovery (%)	50	25	
							150	50	
							SPT N Value (Blows/0.3 m)	Liquid Limit (%)	
							20	25	
							40	50	
							60	75	
							80		
20									
21			▲▼	SS7	WH	100		85	▼
22			▲▼				24		
23	7						24		
24							0		
25							0		
26	8						0		
27							0		
28							0		
29							0		
30	9						0		
31							0		
32							0		
33	10						0		
34							0		
35							0		
36	11						0		
37							0		
38							0		
39							0		

**NOTES**



**Project No.:** 220487  
**Client:** Entrepreneur Holding Corp.  
**Date:** November 17, 2022

**Borehole Log (continued): BH2**

**Project:** Proposed Warehouse  
**Location:** 363 Entrepreneur Cres. Vars ON  
**Field Personnel:** BJ

**Driller:** CCC Geotech and Enviro Drilling

**Drilling Equipment:** Track Mount CME 75

**Drilling Method:** Hollow Stew Auger

SUBSURFACE PROFILE		SAMPLE DATA					Shear Strength (kPa)	Water Content (%)	Monitoring Well Details				
Depth	Soil Description	Elev./Depth (m)	Type	Sample Number	N or RQD	Recovery (%)	50	150		25	50	75	
							SPT N Value (Blows/0.3 m)			Liquid Limit (%)			
							20	40	60	80	25	50	75
40													
41													
42													
43	13						5						
44							5						
45							6						
46	14						6						
47							7						
48							7						
49	15						6						
50							7						
51							9						
52							8						
53	16						9						
54							10						
55							11						
56	17						12						
57							13						
58							12						
59							13						

**NOTES**



Project No.: 220487

Client: Entrepreneur Holding Corp.

Date: November 17, 2022

**Borehole Log (continued): BH2**

Project: Proposed Warehouse

Location: 363 Entrepreneur Cres. Vars ON

Field Personnel: BJ

Driller: CCC Geotech and Enviro Drilling

Drilling Equipment: Track Mount CME 75

Drilling Method: Hollow Stew Auger

SUBSURFACE PROFILE		SAMPLE DATA					Shear Strength (kPa)	Water Content (%)	Monitoring Well Details
Depth	Soil Description	Elev./Depth (m)	Type	Sample Number	N or RQD	Recovery (%)	50	25	
							150	50	
							SPT N Value (Blows/0.3 m)	Liquid Limit (%)	
							20	25	
							40	50	
							60	75	
							80		
60	INFERRED GLACIAL TILL	81.56 18.60					17		
61							21		
62							20		
63							14		
64							20		
65							15		
66							15		
67							15		
68							15		
69							13		
70							18		
71							15		
72							15		
73							16		
74							17		
75							17		
76							16		
77							27		
78							35		
							47		

**NOTES**



**Project No.:** 220487  
**Client:** Entrepreneur Holding Corp.  
**Date:** November 17, 2022

**Borehole Log (continued): BH2**

**Project:** Proposed Warehouse  
**Location:** 363 Entrepreneur Cres. Vars ON  
**Field Personnel:** BJ

**Driller:** CCC Geotech and Enviro Drilling

**Drilling Equipment:** Track Mount CME 75

**Drilling Method:** Hollow Stew Auger

SUBSURFACE PROFILE		SAMPLE DATA					Shear Strength (kPa)	Water Content (%)	Monitoring Well Details
Depth	Soil Description	Elev./Depth (m)	Type	Sample Number	N or RQD	Recovery (%)	50	25	
							150	50	
							SPT N Value (Blows/0.3 m)	Liquid Limit (%)	
							20	25	50
							40	50	75
							60		
							80		
79	End of Borehole	75.67					44		
80		24.50					50		
81									
82									
83									
84									
85									
86									
87									
88									
89									
90									
91									
92									
93									
94									
95									
96									
97									
98									

**NOTES**



**Project No.:** 220487  
**Client:** Entrepreneur Holding Corp.  
**Date:** November 17, 2022

**Borehole Log: BH3**  
**Project:** Proposed Warehouse  
**Location:** 363 Entrepreneur Cres. Vars ON  
**Field Personnel:** BJ

**Driller:** CCC Geotech and Enviro Drilling

**Drilling Equipment:** Track Mount CME 75

**Drilling Method:** Hollow Stew Auger

SUBSURFACE PROFILE		SAMPLE DATA					Shear Strength (kPa)	Water Content (%)	Monitoring Well Details Dec 6, 2022			
Depth ft m	Soil Description	Elev./Depth (m)	Type	Sample Number	N or RQD	Recovery (%)	50	150		25	50	75
							SPT N Value (Blows/0.3 m)			Liquid Limit (%)		
0	Ground Surface	100.18										
0	<b>FILL MATERIAL</b> crushed stone, grey, moist, dense.	0.00		SS1	36	50	36		11			
1		99.49										
1	<b>SILTY SAND</b> brown, moist, compact.	0.69		SS2	14	50	14					
2		98.73										
2	<b>CLAYEY SILT</b> trace sand, grey, very soft, wet.	1.45		SS3	1	100	1			83		
3							20					
3							32					
3							0					
3	-Sand seam at about 3.65 m bgs			SS4	WH	100	0					
4		96.06										
4	<b>SILTY CLAY</b> grey, very soft, wet.	4.12										
5										61	90	
5				SS5	WH	100	0					
6							32					
6							32					
7							24					
7							24					
7	End of Borehole	93.18										
7		7.00										

**Easting:** 465745 m      **Northing:** 5020920 m  
**Site Datum:** TBM - Top of Culvert located at Southwest of Driveway entrance. (100.00 m)  
**Groundsurface Elevation:** 100.180 m      **Top of Riser Elev.:** NA  
**Hole Diameter:** 200 mm      **Monitoring Well Diameter:** 19 mm

**NOTES:**



**Project No.:** 220487  
**Client:** Entrepreneur Holding Corp.  
**Date:** November 17, 2022

**Borehole Log: BH4**  
**Project:** Proposed Warehouse  
**Location:** 363 Entrepreneur Cres. Vars ON  
**Field Personnel:** BJ

**Driller:** CCC Geotech and Enviro Drilling

**Drilling Equipment:** Track Mount CME 75

**Drilling Method:** Hollow Stew Auger

SUBSURFACE PROFILE		SAMPLE DATA					Shear Strength (kPa)	Water Content (%)	Monitoring Well Details
Depth ft / m	Soil Description	Elev./Depth (m)	Type	Sample Number	N or RQD	Recovery (%)	50 150	25 50 75	
							SPT N Value (Blows/0.3 m)	Liquid Limit (%)	
0	Ground Surface	100.22							
0	<b>FILL MATERIAL</b> crushed stone, grey, moist, dense.	0.00	▲	SS1	35	33	35		
1		99.63	▲						
2	<b>SILTY SAND</b> brown, moist, compact.	0.60	▲	SS2	14	50	14	24	
3		98.77	▲						
4	<b>CLAYEY SILT</b> trace sand, grey, firm to very soft, wet.	1.45	▲	SS3	2	100	2	67	77
5			▲						
6			▲						
7			▲						
8			▲				24		
9			▲				24		
10			▲				24		
11			▲	SS4	WH	100	0		
12			▲						
13			▲						
14	<b>SILTY CLAY</b> grey, very soft, wet.	96.10	▲				24		
15		4.12	▲				22		
16			▲						
17			▲						
18			▲				26		
19			▲				24		
20			▲						
21			▲						
22			▲				28		
23		93.22	▲				24		
24	End of Borehole	7.00	▲						

**Easting:** 465770 m      **Northing:** 5020920 m  
**Site Datum:** TBM - Top of Culvert located at Southwest of Driveway entrance. (100.00 m)  
**Groundsurface Elevation:** 100.225 m      **Top of Riser Elev.:** NA  
**Hole Diameter:** 200 mm      **Monitoring Well Diameter:** N/A

**NOTES:**



**APPENDIX C**  
**Symbols and Terms used in Borehole Logs**

# Symbols and Terms Used on Borehole and Test Pit Logs

## 1. Soil Description

The soil descriptions presented in this report are based on commonly accepted methods of classification and identification employed in geotechnical practice. Classification and identification of soil involves some judgement and LRL Associates Ltd. does not guarantee descriptions as exact, but infers accuracy to the extent that is common in current geotechnical practice. Boundaries between zones on the logs are often not distinct but transitional and were interpreted.

### a. Proportion

The proportion of each constituent part, as defined by the grain size distribution, is denoted by the following terms:

Term	Proportions
“trace”	1% to 10%
“some”	10% to 20%
prefix (i.e. “sandy” silt)	20% to 35%
“and” (i.e. sand “and” gravel)	35% to 50%

### b. Compactness and Consistency

The state of compactness of granular soils is defined on the basis of the Standard Penetration Number (N) as per ASTM D-1586. It corresponds to the number of blows required to drive 300 mm of the split spoon sampler using a metal drop hammer that has a weight of 62.5 kg and free fall distance of 760 mm. For a 600 mm long split spoon, the blow counts are recorded for every 150 mm. The “N” value is obtained by adding the number of blows from the 2<sup>nd</sup> and 3<sup>rd</sup> count. Technical refusal indicates a number of blows greater than 50.

The consistency of clayey or cohesive soils is based on the shear strength of the soil, as determined by field vane tests and by a visual and tactile assessment of the soil strength.

The state of compactness of granular soils is defined by the following terms:

State of Compactness Granular Soils	Standard Penetration Number “N”	Relative Density (%)
Very loose	0 – 4	<15
Loose	4 – 10	15 – 35
Compact	10 - 30	35 – 65
Dense	30 - 50	65 - 85
Very dense	> 50	> 85

The consistency of cohesive soils is defined by the following terms:

Consistency Cohesive Soils	Undrained Shear Strength ( $C_u$ ) (kPa)	Standard Penetration Number “N”
Very soft	<12.5	<2
Soft	12.5 - 25	2 - 4
Firm	25 - 50	4 - 8
Stiff	50 - 100	8 - 15
Very stiff	100 - 200	15 - 30
Hard	>200	>30

### c. Field Moisture Condition

Description (ASTM D2488)	Criteria
Dry	Absence of moisture, dusty, dry to touch.
Moist	Damp, but not visible water.
Wet	Visible, free water, usually soil is below water table.

## 2. Sample Data

### a. Elevation depth

This is a reference to the geodesic elevation of the soil or to a benchmark of an arbitrary elevation at the location of the borehole or test pit. The depth of geological boundaries is measured from ground surface.

**b. Type**

Symbol	Type	Letter Code
	Auger	AU
▲	Split Spoon	SS
	Shelby Tube	ST
	Rock Core	RC

**c. Sample Number**

Each sample taken from the borehole is numbered in the field as shown in this column.

LETTER CODE (as above) – Sample Number.

**d. Recovery (%)**

For soil samples this is the percentage of the recovered sample obtained versus the length sampled. In the case of rock, the percentage is the length of rock core recovered compared to the length of the drill run.

**3. Rock Description**

Rock Quality Designation (RQD) is a rough measure of the degree of jointing or fracture in a rock mass. The RQD is calculated as the cumulative length of rock pieces recovered having lengths of 100 mm or more divided by the length of coring. The qualitative description of the bedrock based on RQD is given below.

Rock Quality Designation (RQD) (%)	Description of Rock Quality
0 – 25	Very poor
25 – 50	Poor
50 – 75	Fair
75 – 90	Good
90 – 100	Excellent

Strength classification of rock is presented below.

Strength Classification	Range of Unconfined Compressive Strength (MPa)
Extremely weak	< 1
Very weak	1 – 5
Weak	5 – 25
Medium strong	25 – 50
Strong	50 – 100
Very strong	100 – 250
Extremely strong	> 250

**4. General Monitoring Well Data**

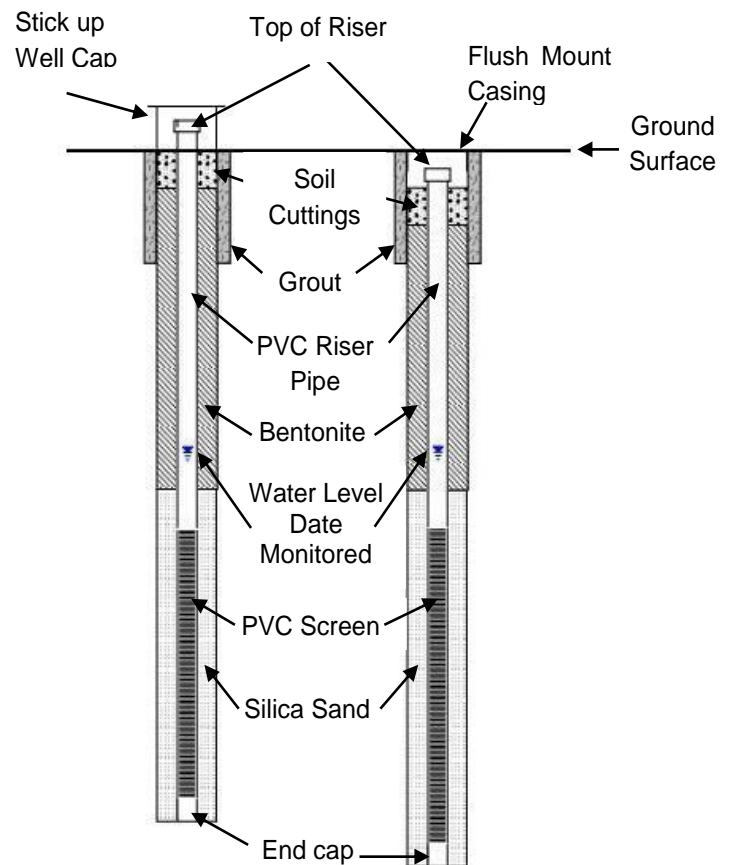

**5. Classification of Soils for Engineering Purposes (ASTM D2487)  
(United Soil Classification System)**

Major divisions		Group Symbol	Typical Names	Classification Criteria
Coarse-grained soils More than 50% retained on No. 200 sieve* (>0.075 mm)	Gravels More than 50% of coarse fraction retained on No. 4 sieve(4.75 mm)	Clean gravels <5% fines	GW Well-graded gravel	<p>Classification on basis of percentage of fines:                      Less than 5% pass No. 200 sieve - GW, GP, SW, SP                      More than 12% pass No. 200 sieve - GM, GC, SM, SC                      5 to 12% pass No. 200 sieve - Borderline classifications, use of dual symbols</p> <p><math>C_u = \frac{D_{60}}{D_{10}} \geq 4</math>; <math>C_c = \frac{(D_{30})^2}{D_{10} \times D_{60}}</math> between 1 and 3</p> <p>Not meeting either <math>C_u</math> or <math>C_c</math> criteria for GW</p> <p>Atterberg limits below "A" line or PI less than 4                      Atterberg limits on or above "A" line and PI &gt; 7                      Atterberg limits plotting in hatched area are borderline classifications requiring use of dual symbols                      If fines are organic add "with organic fines" to group name</p> <p><math>C_u = \frac{D_{60}}{D_{10}} \geq 6</math>; <math>C_c = \frac{(D_{30})^2}{D_{10} \times D_{60}}</math> between 1 and 3</p> <p>Not meeting either <math>C_u</math> or <math>C_c</math> criteria for SW</p> <p>Atterberg limits below "A" line or PI less than 4                      Atterberg limits on or above "A" line and PI &gt; 7                      Atterberg limits plotting in hatched area are borderline classifications requiring use of dual symbols                      If fines are organic add "with organic fines" to group name</p>
		GP Poorly graded gravel		
		Gravels with >12% fines	GM Silty gravel	
		GC Clayey gravel		
	Sands 50% or more of coarse fraction passes No. 4 sieve(<4.75 mm)	Clean sands <5% fines	SW Well-graded sand	
		SP Poorly graded sand		
		Sands with >12% fines	SM Silty sand	
		SC Clayey sand		
Fine-grained soils 50% or more passes No. 200 sieve* (<0.075 mm)	Silt and Clays Liquid Limit <50%	Inorganic	ML Silt	<p>If 15 to 29% coarse-grained, add "with sand" or "with gravel" as appropriate.                      If &gt; 30% coarse-grained, add "sandy" or "gravelly" as appropriate.                      Class as organic when oven dried liquid limit is &lt; 75% of undried liquid limit.</p>
		CL Lean Clay -low plasticity		
		Organic	OL Organic clay or silt (Clay plots above 'A' Line)	
	Silt and Clays Liquid Limit >50%	Inorganic	MH Elastic silt	
		CH Fat Clay -high plasticity		
		Organic	OH Organic clay or silt (Clay plots above 'A' Line)	
	Highly Organic Soils	PT	Peat, muck and other highly organic soils	

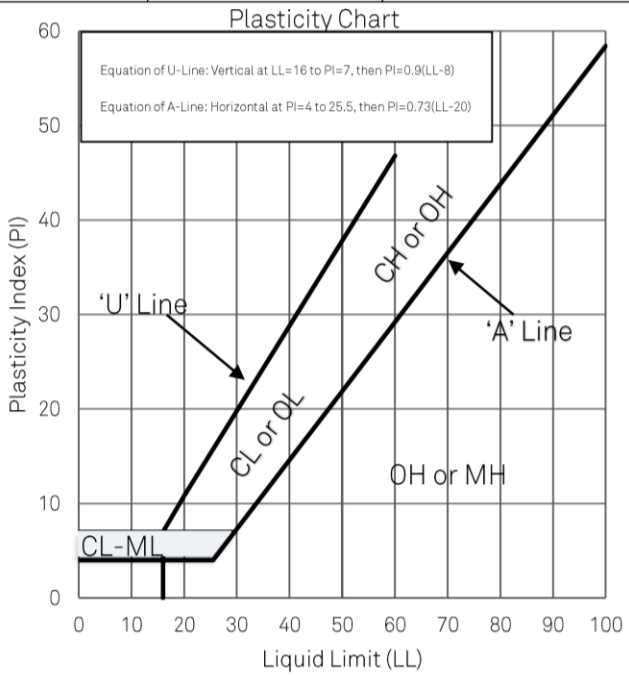

**APPENDIX D**  
**Laboratory Results**



LRL Associates Ltd.  
**PLASTICITY INDEX**  
 ASTM D 4318 / LS-703/704

**Client:** Entrepreneur Holding Corporation  
**Project:** Geotechnical Investigation  
**Location:** 363 Entrepreneur Crescent, Navan, ON.

**File No.:** 220487  
**Report No.:** 1  
**Date:** November 17, 2022

**Plasticity Chart**

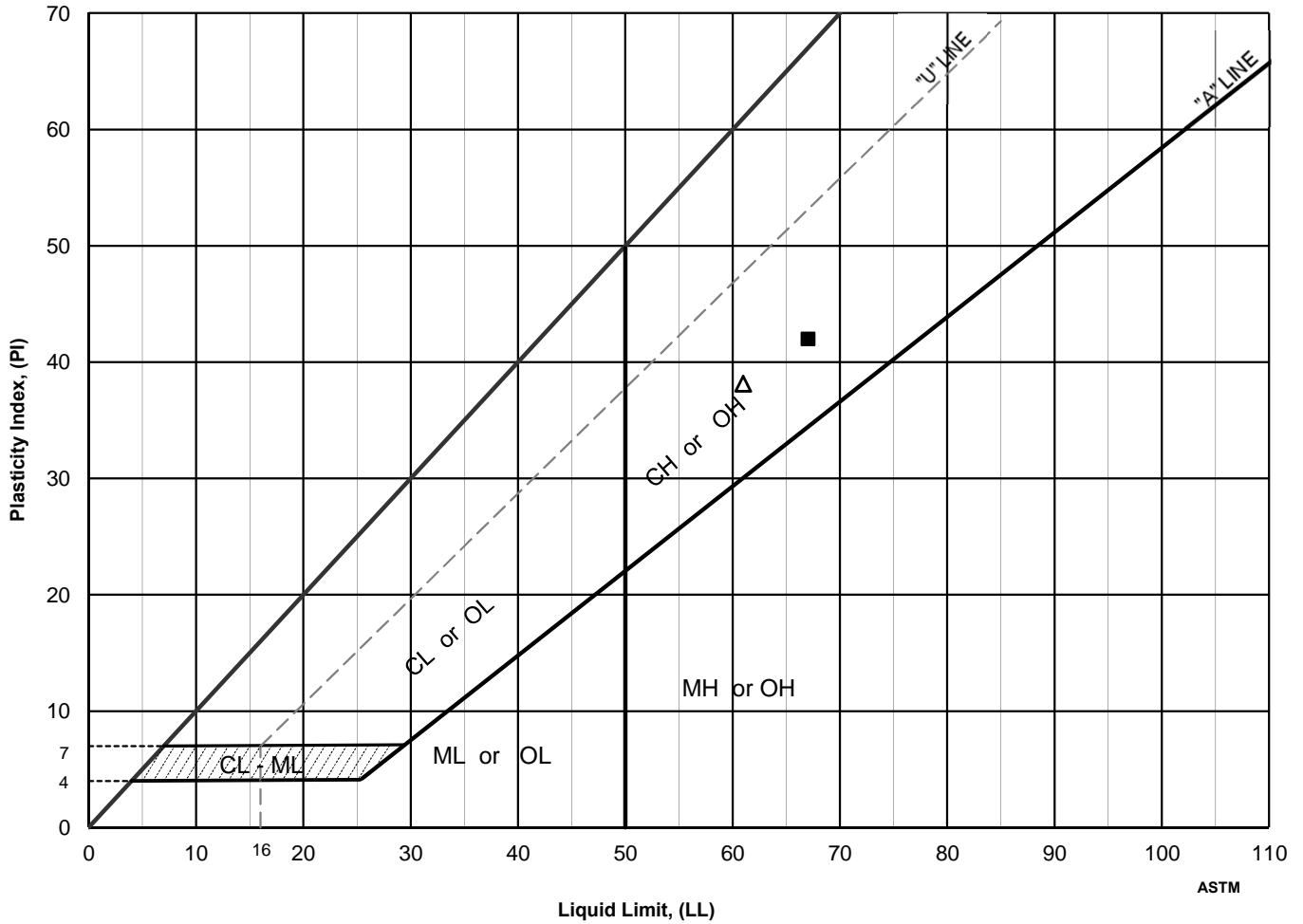

	Location	Sample	Depth, m	Moisture Content, %	Liquid Limit	Plastic Limit	Plasticity Index	Liquidity Index	Activity Number	USCS
△	BH 3	SS-5	4.57 - 5.18	90	61	23	38	1.75	n/d	CH
■	BH 4	SS-3	1.52 - 2.13	77	67	25	42	1.24	n/d	CH





LRL Associates Ltd.

# PARTICLE SIZE ANALYSIS

ASTM D 422 / LS-702

**Client:** Entrepreneur Holding Corporation  
**Project:** Geotechnical Investigation  
**Location:** 363 Entrepreneur Crescent, Navan, ON.

**File No.:** 220487  
**Report No.:** 2  
**Date:** November 17, 2022

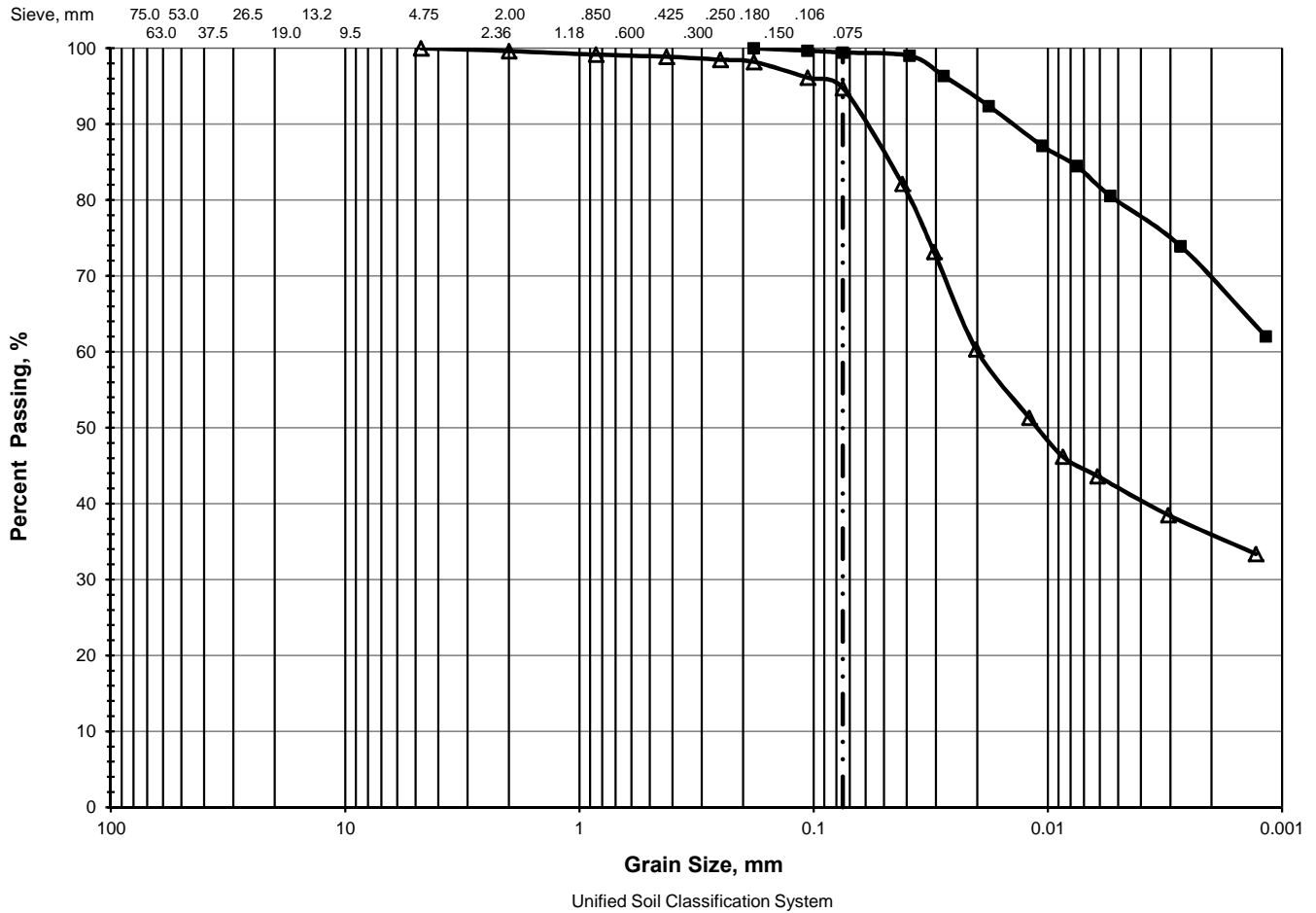

> 75 mm	% GRAVEL		% SAND			% FINES	
	Coarse	Fine	Coarse	Medium	Fine	Silt	Clay
△	0.0	0.0	0.4	0.8	4.1	59.3	35.4
■	0.0	0.0	0.0	0.0	0.6	31.0	68.4

Location	Sample	Depth, m	D <sub>60</sub>	D <sub>50</sub>	D <sub>30</sub>	D <sub>15</sub>	D <sub>10</sub>	C <sub>c</sub>	C <sub>u</sub>
△	BH 1	1.52 - 2.13	0.0199	0.0111					
■	BH 2	6.10 - 6.71							



## Certificate of Analysis

**LRL Associates Ltd.**

5430 Canotek Road  
Ottawa, ON K1J 9G2  
Attn: Brad Johnson

Client PO:  
Project: 220487  
Custody: 141038

Report Date: 6-Dec-2022  
Order Date: 30-Nov-2022

**Order #: 2249226**

This Certificate of Analysis contains analytical data applicable to the following samples as submitted:

Parcel ID	Client ID
2249226-01	BH 4 5-7'

Approved By:



Milan Ralitsch, PhD  
Senior Technical Manager



Certificate of Analysis

Report Date: 06-Dec-2022

Client: LRL Associates Ltd.

Order Date: 30-Nov-2022

Client PO:

Project Description: 220487

**Analysis Summary Table**

Analysis	Method Reference/Description	Extraction Date	Analysis Date
Anions	EPA 300.1 - IC, water extraction	2-Dec-22	2-Dec-22
pH, soil	EPA 150.1 - pH probe @ 25 °C, CaCl buffered ext.	1-Dec-22	2-Dec-22
Resistivity	EPA 120.1 - probe, water extraction	5-Dec-22	5-Dec-22
Solids, %	CWS Tier 1 - Gravimetric	1-Dec-22	2-Dec-22

Certificate of Analysis

Report Date: 06-Dec-2022

Client: LRL Associates Ltd.

Order Date: 30-Nov-2022

Client PO:

Project Description: 220487

## Summary of Criteria Exceedances

(If this page is blank then there are no exceedances)

Only those criteria that a sample exceeds will be highlighted in red

### Regulatory Comparison:

Paracel Laboratories has provided regulatory guidelines on this report for informational purposes only and makes no representations or warranties that the data is accurate or reflects the current regulatory values. The user is advised to consult with the appropriate official regulations to evaluate compliance. Sample results that are highlighted have exceeded the selected regulatory limit. Calculated uncertainty estimations have not been applied for determining regulatory exceedances.

Sample	Analyte	MDL / Units	Result	-	-
--------	---------	-------------	--------	---	---

Certificate of Analysis

Report Date: 06-Dec-2022

Client: LRL Associates Ltd.

Order Date: 30-Nov-2022

Client PO:

Project Description: 220487

<b>Client ID:</b>	BH 4 5-7'	-	-	-	-
<b>Sample Date:</b>	17-Nov-22 12:00	-	-	-	-
<b>Sample ID:</b>	2249226-01	-	-	-	-
<b>Matrix:</b>	Soil	-	-	-	-
<b>MDL/Units</b>					

**Physical Characteristics**

% Solids	0.1 % by Wt.	56.5	-	-	-	-
----------	--------------	------	---	---	---	---

**General Inorganics**

pH	0.05 pH Units	7.44	-	-	-	-
Resistivity	0.1 Ohm.m	21.2	-	-	-	-

**Anions**

Chloride	5 ug/g	101	-	-	-	-
Sulphate	5 ug/g	78	-	-	-	-

Certificate of Analysis

Report Date: 06-Dec-2022

Client: LRL Associates Ltd.

Order Date: 30-Nov-2022

Client PO:

Project Description: 220487

**Method Quality Control: Blank**

Analyte	Result	Reporting Limit	Units	%REC	%REC Limit	RPD	RPD Limit	Notes
<b>Anions</b>								
Chloride	ND	5	ug/g					
Sulphate	ND	5	ug/g					
<b>General Inorganics</b>								
Resistivity	ND	0.10	Ohm.m					

Certificate of Analysis

Report Date: 06-Dec-2022

Client: LRL Associates Ltd.

Order Date: 30-Nov-2022

Client PO:

Project Description: 220487

**Method Quality Control: Duplicate**

Analyte	Result	Reporting Limit	Units	Source Result	%REC	%REC Limit	RPD	RPD Limit	Notes
<b>Anions</b>									
Chloride	18.5	5	ug/g	18.1			2.4	20	
Sulphate	10.5	5	ug/g	9.28			12.3	20	
<b>General Inorganics</b>									
pH	8.02	0.05	pH Units	7.91			1.4	10	
Resistivity	21.4	0.10	Ohm.m	21.3			0.4	20	
<b>Physical Characteristics</b>									
% Solids	82.6	0.1	% by Wt.	82.4			0.2	25	

Certificate of Analysis

Report Date: 06-Dec-2022

Client: LRL Associates Ltd.

Order Date: 30-Nov-2022

Client PO:

Project Description: 220487

**Method Quality Control: Spike**

Analyte	Result	Reporting Limit	Units	Source Result	%REC	%REC Limit	RPD	RPD Limit	Notes
<b>Anions</b>									
Chloride	126	5	ug/g	18.1	108	82-118			
Sulphate	121	5	ug/g	9.28	112	80-120			

Certificate of Analysis

Report Date: 06-Dec-2022

Client: LRL Associates Ltd.

Order Date: 30-Nov-2022

Client PO:

Project Description: 220487

**Qualifier Notes:**

**Sample Data Revisions:**

None

**Work Order Revisions / Comments:**

None

**Other Report Notes:**

n/a: not applicable

ND: Not Detected

MDL: Method Detection Limit

Source Result: Data used as source for matrix and duplicate samples

%REC: Percent recovery.

RPD: Relative percent difference.

NC: Not Calculated

Soil results are reported on a dry weight basis unless otherwise noted.

Where %Solids is reported, moisture loss includes the loss of volatile hydrocarbons.

Any use of these results implies your agreement that our total liability in connection with this work, however arising, shall be limited to the amount paid by you for this work, and that our employees or agents shall not under any circumstances be liable to you in connection with this work.

6% - 8% AIR ENTRAINED  
 35 MPa (5000 psi) @ 28 DAYS  
 AS PER CSA A23.4-09 STANDARD

GENERAL NOTES:

A PUMP STATION IS REQUIRED WHEN A SEPTIC SYSTEM IS UNABLE TO FUNCTION BY GRAVITY.

FROM 8.6.1.3. (3) OF THE O.B.C. 2006, WHERE 2 OR MORE PUMPS ARE EMPLOYED WITHIN A DOSING TANK, THE PUMPS SHALL BE DESIGNED SUCH THAT THE PUMPS ALTERNATE DOSING, AND DOSING SHALL CONTINUE IN THE EVENT THAT ONE OF THE PUMP FAILS.

FROM 8.6.1.3. (4) OF THE O.B.C. 2006, WHERE A PUMP OR SIPHON IS REQUIRED, THE PUMP OR SIPHON SHALL BE DESIGNED TO DISCHARGE A DOSE OF AT LEAST 75% OF THE INTERNAL VOLUME OF THE DISTRIBUTION PIPE WITHIN A TIME PERIOD NOT EXCEEDING 15 MINUTES.

A PUMP STATION SHALL HAVE A WORKING VOLUME OF A THIRD OF THE DAILY FLOW OF THE SEPTIC SYSTEM IT IS DESIGNED FOR.

PUMP STATION ARE AVAILABLE IN MULTIPLE SIZES, AND MULTIPLE PUMP SIZES ALSO AVAILABLE. DUAL PUMP STATION ALSO AVAILABLE, SEE LIST BELOW, VOLUME INDICATED IS MAXIMUM WORKING VOLUME:

- 175 GAL / 800 LITERS : 3 FEET  $\phi$  - 4 FEET WELL TILE
- 250 GAL / 1135 LITERS : 3 FEET  $\phi$  - 6 FEET WELL TILE
- 450 GAL / 2045 LITERS : 4 FEET  $\phi$  - 6 FEET WELL TILE
- DUAL - 760 GAL / 3450 LITERS : NORMAL 800 GAL / 3630 L TANK
- DUAL - 1175 GAL / 5340 LITERS : NORMAL 1210 GAL / 5509 L TANK

ALARMS, ELECTRICAL BOXES AND CHECK VALVES MAY DIFFERS FROM ONE PUMP STATION SYSTEMS TO ANOTHER. SIMPLEX AND DUPLEX TIME DOSING CONTROL PANEL AVAILABLE.

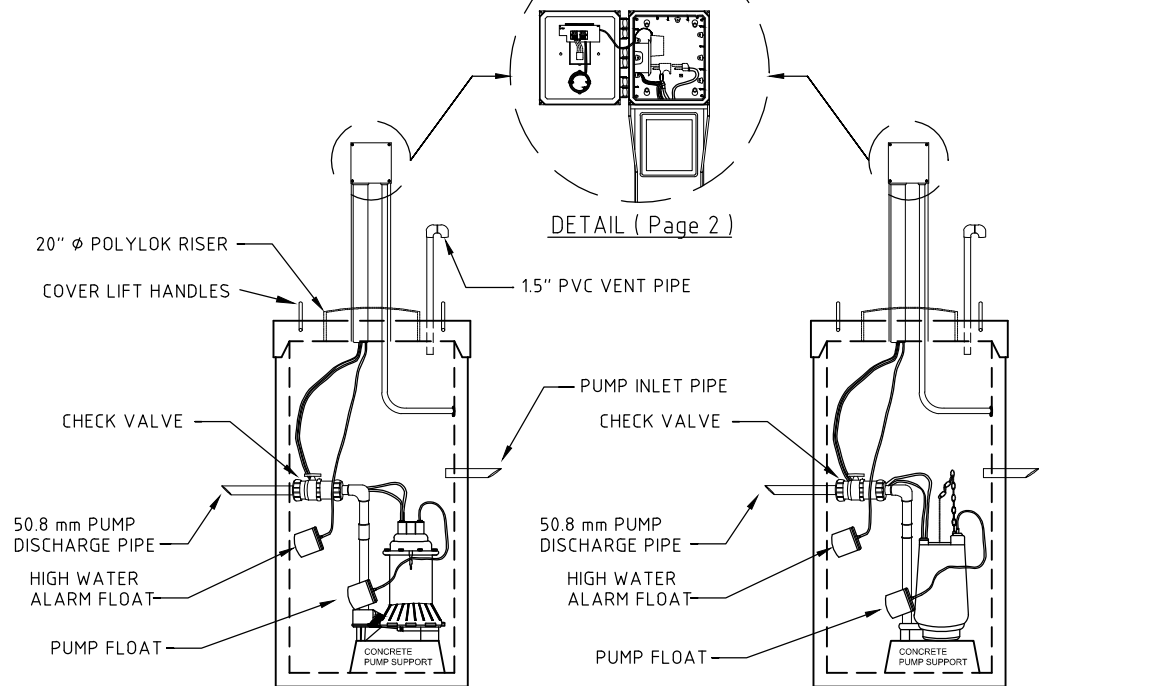

SRM 4 0.40 HP PUMP SYSTEM

MRG 20 2.0 HP GRINDER PUMP SYSTEM

BOTH PUMP SHOWN ARE 250 GAL / 1135 L PUMP STATIONS, NOT TO SCALE

SIDE VIEW

16525 SIXTH RD, MOOSE CREEK, ON  
 KOC 1W0  
 PHONE : (613)-538-2381  
 FAX : (613)-538-4870

MOOSE CREEK CEMENT PRODUCTS (2006) LIMITED  
 PUMP STATION SIDE VIEW ( Page 1 / 2 )

SCALE

NOT TO SCALE

DATE

JULY 2011

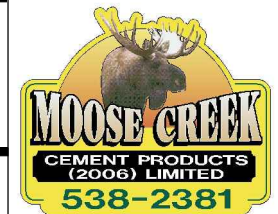





# WW05 Series Model 3872

SUBMERSIBLE SEWAGE PUMPS

### FEATURES

Impeller: Glass-filled thermoplastic Full-Vortex design with pump out vanes for mechanical seal protection.

Casing and Base: Rugged glass-filled thermoplastic design provides superior strength and corrosion resistance.

Motor Housing: Cast iron for efficient heat transfer, strength, and durability.

Motor Cover: Thermoplastic cover with integral handle and float switch attachment points.

Bearings: Upper and lower heavy duty ball bearing construction.

Power Cable: Severe duty rated oil and water resistant.

O-ring: Provides positive sealing. Easily replaced during maintenance.

Stainless steel fasteners

### AGENCY LISTINGS



By Canadian Standards Association

### APPLICATIONS

Specifically designed for the following uses:

- Residential sewage systems
- Dewatering
- Water transfer

Anywhere waste or drainage must be disposed of quickly, quietly and efficiently.

### SPECIFICATIONS

#### Pump:

- Solids handling capability: 2" maximum
- Capacities: up to 75 GPM
- Total heads: up to 18 feet
- Discharge size: 2" NPT
- Mechanical seal: carbon-rotary/ceramic-stationary, BUNA-N elastomers

- Temperature:
  - 104° F (40° C) continuous
  - 140° F (60° C) intermittent
- Class B Insulation
- Fasteners: 300 series stainless steel
- Capable of running dry without damage to components.

#### Motor

- Single phase: ½ HP, 115 or 230 V, 60 Hz, 1550 RPM, built in overload with automatic reset.
- Power cord: 10 foot standard length, 16/3 SJTW with three prong grounding plug. Optional 20 foot length, 16/3 SJTW with three prong grounding plug.
- Fully submerged in high grade turbine oil for lubrication and efficient heat transfer.

**Available for automatic and manual operation. Automatic models include Mechanical Float Switch assembled and preset at the factory.**

### MODEL INFORMATION

Order No.	HP	Volts	Amps	Minimum Circuit Breaker	Phase	Float Switch Style	Cord Length	Discharge Connection	Minimum On Level	Minimum Off Level	Minimum Basin Diameter	Maximum Solids Size	Shipping Weight lbs/kg
WW0511	.5	115	13	20	1	Plug / No Switch	10'	2"	Manual	Manual	18"	2"	22 / 10
WW0511A						Piggyback / Wide-Angle	10'	2"	15"	9"	18"		23 / 10.4
WW0511F						Plug / No Switch	20'	2"	Manual	Manual	18"		22 / 10
WW0511AC						Piggyback / Wide-Angle	20'	2"	15"	9"	18"		23 / 10.4
WW0512		230	6.5	10		Plug / No Switch	10'	2"	Manual	Manual	18"		22 / 10
WW0512F						Plug / No Switch	20'	2"	Manual	Manual	18"		22 / 10

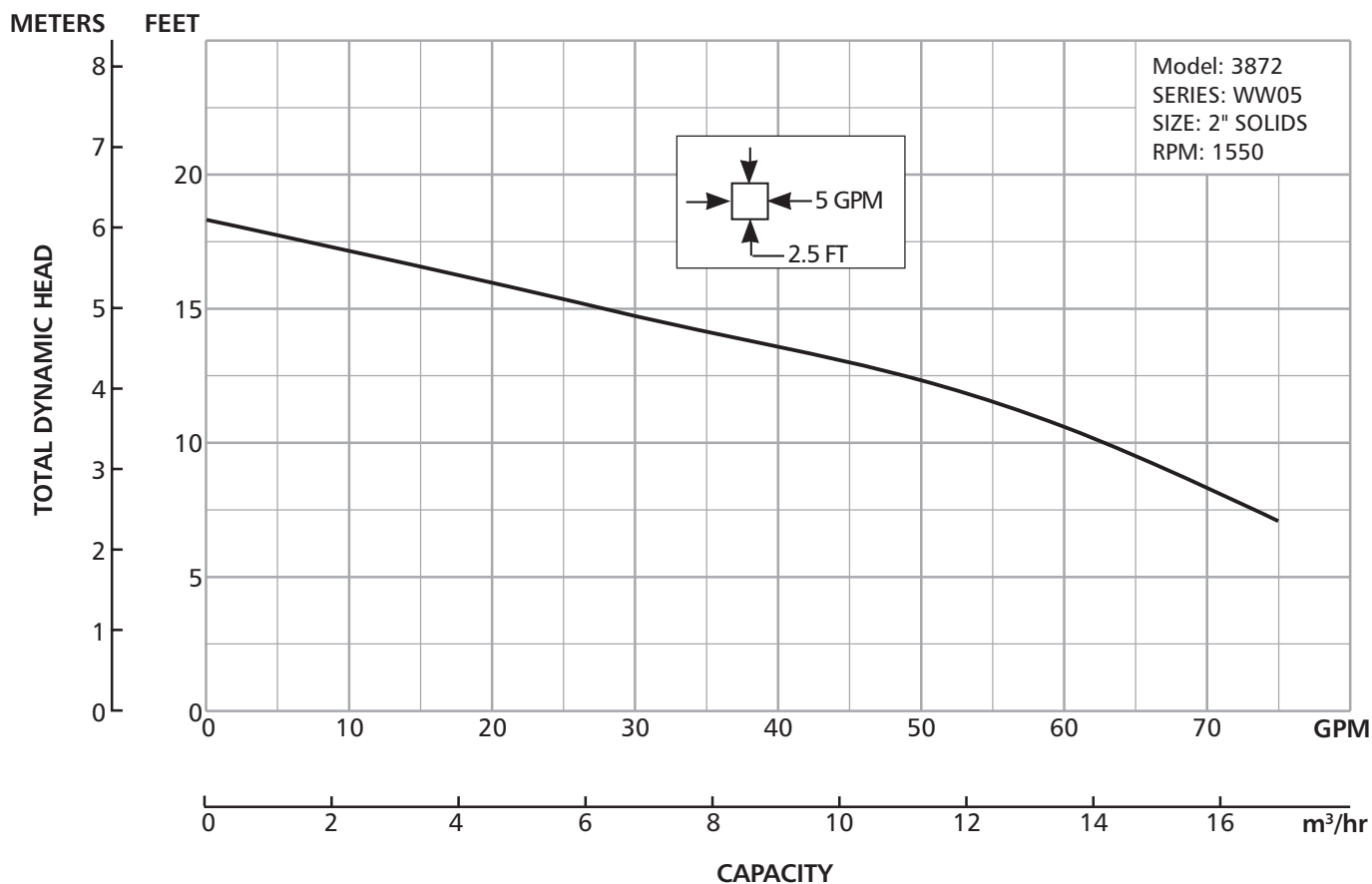

### PERFORMANCE CHARTS

These charts show actual system performance with friction loss factored in for various discharge pipe lengths. Calculations and performance based on a system with 2" PVC, schedule 40 plastic pipe (C150), (4) 90° elbows, (1) check valve and (1) shut-off valve. Wastewater requires a minimum scouring velocity of 21 gpm for 2" pipe. Shaded areas do not provide min. scouring velocity - use only for gray water with no solids.

#### WW05 (3872)

	4	6	8	10	12	14	16
25	75	68	62	52	40	27	13
50	67	61	54	45	35	24	12
75	61	55	48	40	32	22	11
100	56	50	44	37	29	21	11
150	48	43	38	32	26	18	10
200	43	39	34	29	23	17	10
250	39	35	31	26	21	15	10
300	35	32	29	24	20	14	10

## DIMENSIONS

(All dimensions are in inches. Do not use for construction purposes.)

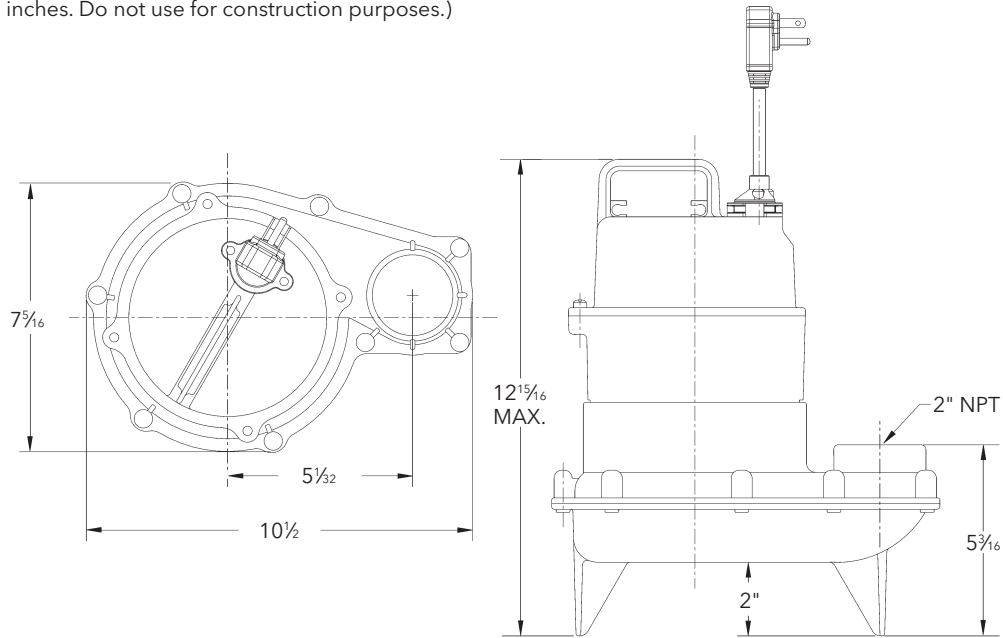

## COMPONENTS *(for reference only)*

Item No.	Description
1	Impeller
2	Rugged thermoplastic base
3	Rugged thermoplastic pump casing
4	Mechanical seal
5	Ball bearings
6	O-rings
7	Power cord
8	Oil filled motor
9	Cast iron motor housing/stator assembly
10	Thermoplastic motor cover

\* Parts available on repair parts selection chart.

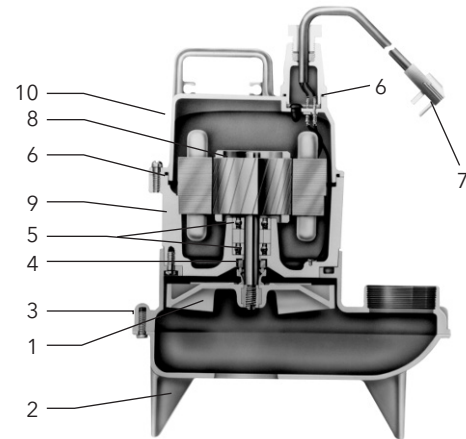

**xylem**  
Let's Solve Water

Xylem, Inc.  
2881 East Bayard Street Ext., Suite A  
Seneca Falls, NY 13148  
Phone: (866) 325-4210  
Fax: (888) 322-5877  
[www.gouldswatertechnology.com](http://www.gouldswatertechnology.com)

Goulds is a registered trademark of Goulds Pumps, Inc. and is used under license.  
© 2012 Xylem Inc. B3872 R1 April 2013

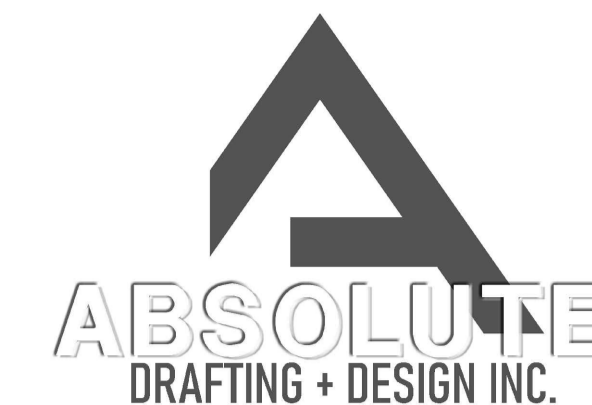

ALL CONTRACTORS SHALL PERFORM THEIR WORK WHETHER DESCRIBED OR NOT, ACCORDING TO THE APPLICABLE BUILDING CODE REQUIREMENTS AND MUNICIPAL REGULATIONS.

THE GENERAL CONTRACTOR SHALL CHECK AND VERIFY ALL DIMENSIONS AND REPORT ERRORS AND OMISSIONS TO THE DESIGN CONSULTANT.

NO DIMENSION SHOULD BE SCALED ON DRAWINGS.

THE GENERAL CONTRACTOR OR SUB-CONTRACTORS WILL BE HELD RESPONSIBLE FOR ALL WORK DONE ON THE CONSTRUCTION SITE. IN NO EVENT WILL THE DESIGNER BE HELD RESPONSIBLE BEFORE, DURING AND AFTER THE PROJECT.

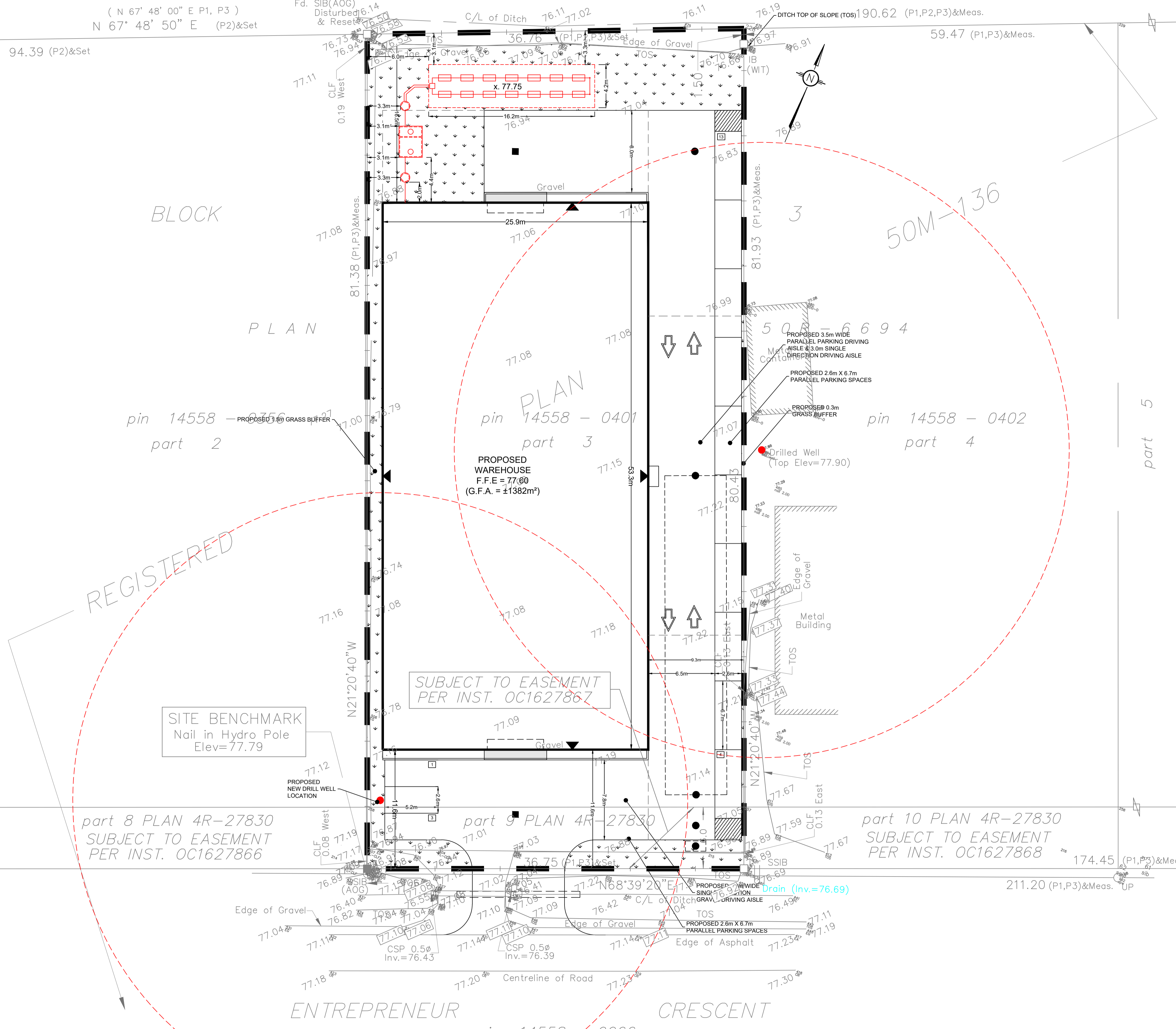

REGISTERED

SUBJECT TO EASEMENT PER INST. OC1627867

SITE BENCHMARK  
Nail in Hydro Pole  
Elev=77.79

part 8 PLAN 4R-27830  
SUBJECT TO EASEMENT  
PER INST. OC1627866

part 9 PLAN 4R-27830

part 10 PLAN 4R-27830  
SUBJECT TO EASEMENT  
PER INST. OC1627868

SCALE:	1:200
DATE:	2023.04.19.
ISSUED FOR PERMIT	
PROJECT:	23A011-REV01

**ABSOLUTE DRAFTING + DESIGN INC.**  
PERS. BCIN #44555  
FIRM. BCIN #45254

I, **ABSOLUTE DRAFTING + DESIGN INC.**, HAVE REVIEWED THE FOLLOWING DOCUMENTS AND TAKE RESPONSIBILITY FOR THE DESIGN ACTIVITIES.

DESSIN/DRAWING  
**SEPTIC LOCATION**

PROJET/PROJECT  
WAREHOUSE DEVELOPMENT  
363 ENTREPRENEUR CR., OTTAWA

CLIENT  
**DUSTIN WILSON**

ALL CONTRACTORS SHALL PERFORM THEIR WORK WHETHER DESCRIBED OR NOT, ACCORDING TO THE APPLICABLE BUILDING CODE REQUIREMENTS AND MUNICIPAL REGULATIONS.

THE GENERAL CONTRACTOR SHALL CHECK AND VERIFY ALL DIMENSIONS AND REPORT ERRORS AND OMISSIONS TO THE DESIGN CONSULTANT.

NO DIMENSION SHOULD BE SCALED ON DRAWINGS.

THE GENERAL CONTRACTOR OR SUB-CONTRACTORS WILL BE HELD RESPONSIBLE FOR ALL WORK DONE ON THE CONSTRUCTION SITE. IN NO EVENT WILL THE DESIGNER BE HELD RESPONSIBLE BEFORE, DURING AND AFTER THE PROJECT.

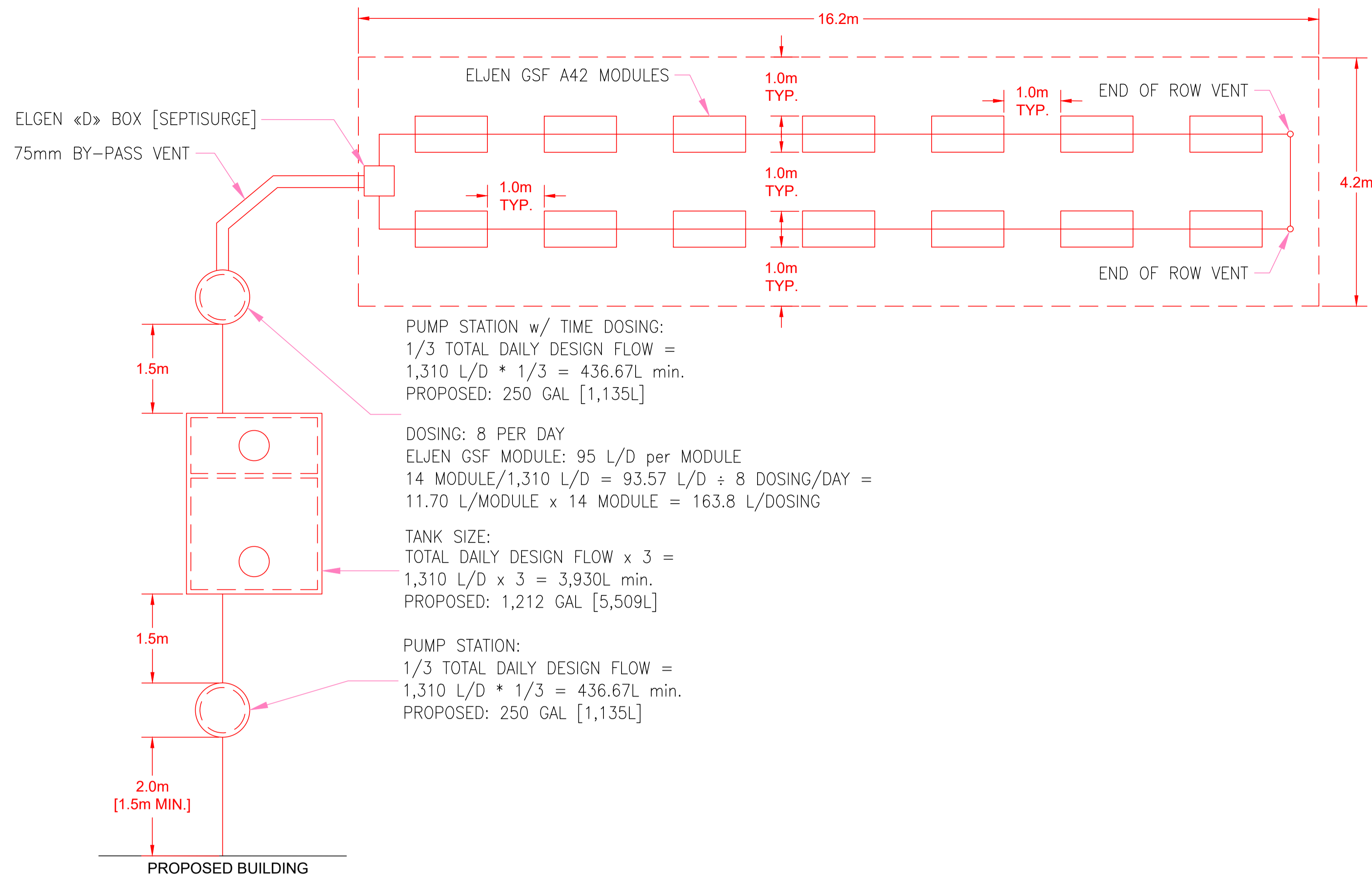

### SEPTIC LAYOUT

SCALE: 1:50

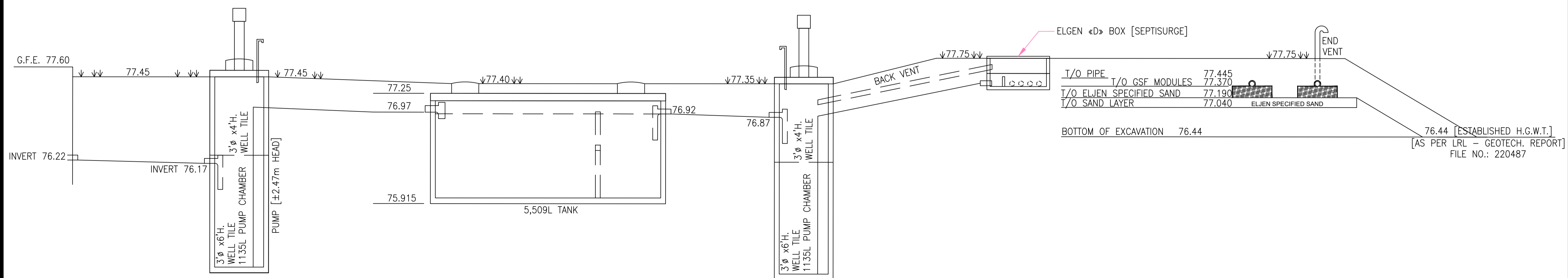

### SEPTIC SECTION

SCALE: 1:35

SCALE:

AS INDICATED

DATE:

2023.04.19.

ISSUED FOR PERMIT

PROJECT:

23A011-REV01

DESSIN/DRAWING

**SEPTIC LAYOUT + SPEC'S**

PROJET/PROJECT

WAREHOUSE DEVELOPMENT  
363 ENTREPRENEUR CR., OTTAWA

CLIENT

DUSTIN WILSON

**ABSOLUTE**  
DRAFTING + DESIGN INC.  
PERS. BCIN #44555  
FIRM. BCIN #45254

I, ABSOLUTE DRAFTING + DESIGN INC., HAVE REVIEWED THE FOLLOWING DOCUMENTS AND TAKE RESPONSIBILITY FOR THE DESIGN ACTIVITIES.

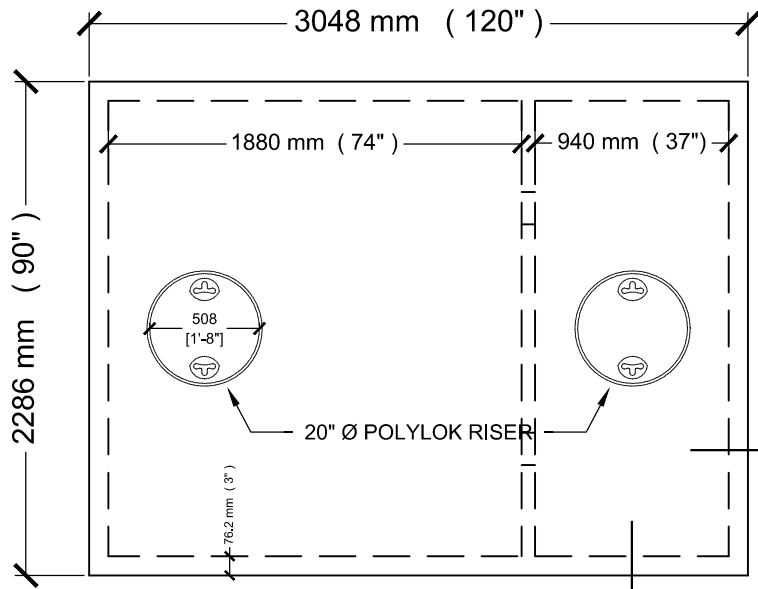

PLAN VIEW

SPECIFICATIONS:

NOMINAL TANK SIZE  
5500 LITER SEPTIC TANK

TOTAL CAPACITY  
6903 LITERS (1518 GAL)  
5509 LITERS (1212 GAL) TO OUTLET

ALL DIMENSIONS DEFAULT TO  
MILLIMETERS mm  
[in]

GENERAL NOTES:

- 1) CONCRETE TO BE 30 MPa @ 28 DAYS WITH 5-8% AIR ENTRAINMENT
- 2) CONCRETE MIX IS NON-SULPHATE RESISTANT
- 3) REINFORCEMENT TO CONFORM TO G30.15 AND CAN/CSA G30.18
- 4) REINFORCEMENT: TOP SLAB REINFORCEMENT  
-10M REBAR EQUALLY SPACED IN BOTH DIRECTION  
BOTTOM SLAB REINFORCEMENT  
-10M REBAR EQUALLY SPACED IN BOTH DIRECTION  
WALL REINFORCEMENT  
-FIBERGLASS MESH ADDED IN CONCRETE MIX
- 5) MINIMUM CONCRETE COVER OVER REINFORCEMENT IS 25.4mm / 1"
- 6) CERTIFIED MINIMUM BURIAL DEPTH: 0.6M ( 24")
- 7) WEIGHT OF TOP SLAB = 1635 KG / 3605 LBS
- 8) WEIGHT OF TANK SECTION = 4,113 KG / 9068 LBS
- 9) ASSEMBLED WEIGHT = 5748 KG / 12672 LBS
- 10) CHAMBER DIVIDER IS CAST SEPARATELY
- 11) NO CENTER JOINT IN TANKS
- 12) 100mmØ INLET AND 75mmØ OUTLET PVC PIPE STUB
- 13) TOP OF OUTLET FITTING EXTENDS TO AT LEAST THE HEIGHT OF CHAMBER DIVIDER WITH 25mm MINIMUM AIR SPACE
- 14) PRODUCT IS FACTORY ASSEMBLED AND AS PER CSA A23.4-09 STANDARD AND CSA B 66-00 STANDARD

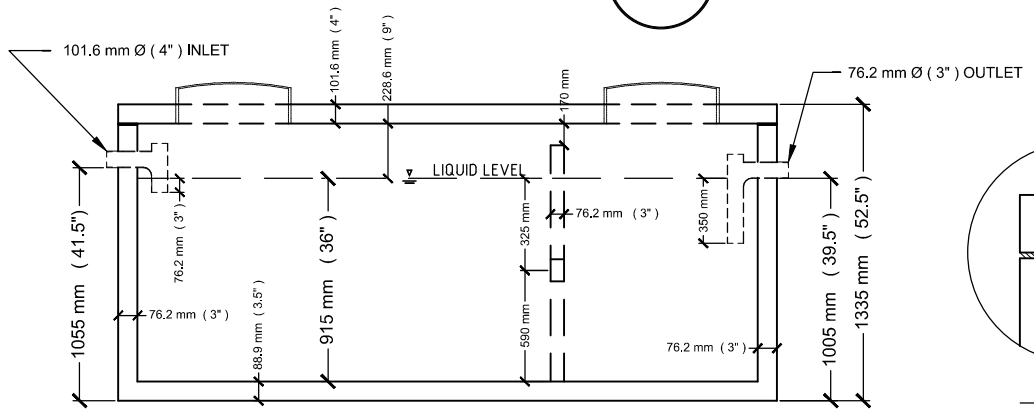

CROSS SECTION A

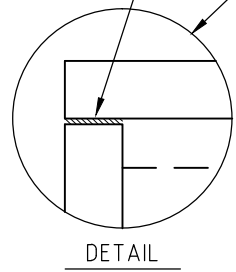

DETAIL

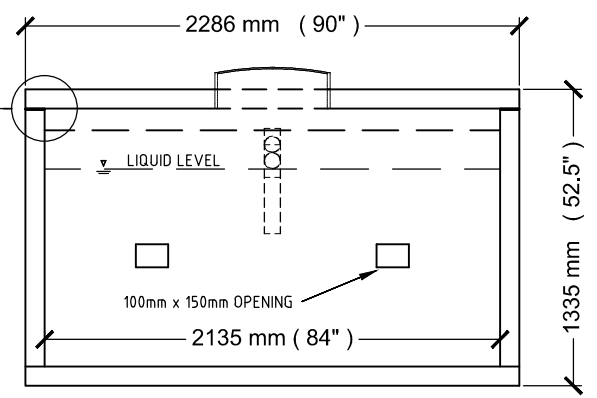

CROSS SECTION B

16525 SIXTH RD, MOOSE CREEK, ON  
KOC 1W0  
PHONE : (613)-538-2381  
FAX : (613)-538-4870

MOOSE CREEK CEMENT PRODUCTS (2006) LIMITED  
LOW-BOY CONCRETE 1212 GALLON / 5509 LITER SEPTIC TANK

SCALE NOT TO SCALE DATE JULY 2011



**TAX BILL /  
RELEVÉ D'IMPOSITION**

2023 INTERIM TAXES /  
TAXES PROVISOIRES 2023

BILLING DATE / DATE DE FACTURATION  
FEB/FÉV 09, 2023

City of Ottawa / Ville d'Ottawa  
Tel. / Tél : 613-580-2444  
Calls will be recorded. / Les appels seront enregistrés.  
TTY / ATS : 613-580-2401

**ROLL / RÔLE: 0614.500.301.60600.0000**  
**ACCESS CODE / CODE D'ACCÈS: NR64AC1**



ENTREPRENEUR HOLDING  
CORPORATION  
310 SANCTUARY PVT  
OTTAWA ON K1S 5W1

ITR 2155

**PROPERTY INFORMATION / INFORMATIONS FONCIÈRES**

ENTREPRENEUR HOLDING  
CORPORATION  
363 ENTREPRENEUR CRES  
PLAN 50M136 PT BLK 3 RP  
50R6694 PART 3  
32291.73SF 120.57FR D

		MUNICIPAL / MUNICIPALE			EDUCATION / SCOLAIRE		
Tax Class / Catégorie d'impôts	Municipal Levies/ Prélèvements Municipal	2022 Annualized Taxes/ Impôts annualisés	Rate / Taux	2023 Amount/ Montant	2022 Annualized Taxes/ Impôts annualisés	Rate / Taux	2023 Amount/ Montant
IXN	CITYWIDE / VILLE ENTIÈRE	784.32	50%	392.16	765.60	50%	382.80
IX-TRA	RURAL TRANSIT / TRANSP RURAL	86.94	50%	43.47			
IX-POL	OTTAWA POLICE D'OTTAWA	228.90	50%	114.45			
IX-FSR	FIRE/INCENDIE SERV	65.44	50%	32.72			
IX-CAL	CONS AUTHORITY/AUT DE CONSERV	10.18	50%	5.09			
<b>SUB-TOTALS / TOTAUX PARTIELS:</b>	<b>Municipal Levy Impôts municipaux</b>			<b>\$587.89</b>	<b>Education Levy Impôts scolaires</b>		<b>\$382.80</b>
SPECIAL CHARGES / CREDITS FRAIS SPÉCIAUX / CRÉDITS				SUMMARY SOMMAIRE			
				Tax Levy Sub-total ( Municipal + Education) Total partiel des impôts (municipaux + scolaires) \$970.69			
				Interim Tax Cap Adjustment Redressement d'impôt intérimaire selon le plafonnement \$0.00			
				Special Charges / Credits Frais spéciaux / Crédits \$0.00			
				2023 Interim Billing Facturation intérimaire 2023 \$970.69			
<b>TOTAL:</b>				<b>Past Due/Credit (as of 09-FEB-2023) Arrrages / Crédit (au 09-FÉV-2023) \$51.13</b>			
<b>DUE DATE / DATE D'ÉCHÉANCE :</b> <b>MAR/MAR 16, 2023</b>				<b>TOTAL AMOUNT DUE/TOTAL DES IMPÔTS EXIGIBLES:</b> <b>\$1,021.82</b>			
<b>PENALTY RATE / TAUX DE PÉNALITÉ</b> 1.25%		<b>Added 1st day of default and 1st day of each month thereafter. Appliqué le 1er jour de défaut de paiement et le 1er jour de chaque mois par la suite.</b>					

Retain this portion for your records.

TB-INT-V1.1.0

Gardez cette partie pour vos dossiers.

**DUE DATE / DATE D'ÉCHÉANCE** **MAR/MAR 16, 2023**

**AMOUNT DUE / SOLDE:** **\$1,021.82**

**Amount Paid / Montant payé**

ROLL NUMBER / NUMÉRO DU RÔLE 0614.500.301.60600.0000

Name / ENTREPRENEUR HOLDING  
Nom CORPORATION

500301606000000001000001021821



2 0 6 1 4 0 0 0 0 1 0 2 1 8 2

5 0 0 3 0 1 6 0 6 0 0 0 0 0 0