

**LEGEND**

---	PROPERTY LINE	---	STRAWBALE CHECK DAM (OPSD 219.180)
---	PROPOSED CURB	---	PROPOSED FILTER BAGS
DC	PROPOSED DEPRESSED CURB	MM	PROPOSED MUD MAT
---	PROPOSED TWISI	STM MH	HEAVY DUTY SILT FENCE (OPSD 219.131)
---	PROPOSED FIREWALL	CB 1	EXISTING STORM MANHOLE
---	PROPOSED BIKE RACKS	LS	EXISTING CATCHBASIN
---	PROPOSED CROSSWALK PAINTING	X	EXISTING LIGHT STANDARD
---	PROPOSED LINE PAINTING	---	EXISTING FENCE
---	PROPOSED GARBAGE COLLECTION BINS	---	EXISTING ROAD SIGNAGE
---	PROPOSED RETAINING WALL		
---	CW GUARD RAIL		
---	PROPOSED CAP		
---	PROPOSED STORM MANHOLE		
---	PROPOSED CATCHBASIN MANHOLE		
---	PROPOSED CATCHBASIN		
---	PROPOSED DITCH INLET CATCH BASIN		
---	PROPOSED LANDSCAPE DRAIN (ELBOW/TEE)		
---	PROPOSED AREA DRAIN		
---	PROPOSED CULVERT		
---	PROPOSED TRENCH DRAIN		
---	PROPOSED BUILDING ENTRANCE		
---	SWALE $\phi$ W SUBDRAIN AND DIRECTION OF FLOW		
---	TERRACING 3:1 SLOPE MAX (UNLESS OTHERWISE INDICATED)		
---	PROPOSED TREE PROTECTION FENCING		

- EROSION AND SEDIMENT CONTROL NOTES:**
- THE CONTRACTOR SHALL IMPLEMENT BEST MANAGEMENT PRACTICES, TO PROVIDE FOR PROTECTION OF THE AREA DRAINAGE SYSTEM AND THE RECEIVING WATERCOURSE, DURING CONSTRUCTION ACTIVITIES. THE CONTRACTOR ACKNOWLEDGES THAT FAILURE TO IMPLEMENT APPROPRIATE EROSION AND SEDIMENT CONTROL MEASURES MAY BE SUBJECT TO PENALTIES IMPOSED BY ANY APPLICABLE REGULATORY AGENCY.
- 1) THE OWNER AGREES TO PREPARE AND IMPLEMENT AN EROSION AND SEDIMENT CONTROL PLAN TO THE SATISFACTION OF THE CITY OF OTTAWA, APPROPRIATE TO THE SITE CONDITIONS, PRIOR TO UNDERTAKING ANY SITE ALTERATIONS (FILLING, GRADING, REMOVAL OF VEGETATION, ETC.) AND DURING ALL PHASES OF SITE PREPARATION AND CONSTRUCTION IN ACCORDANCE WITH THE CURRENT BEST MANAGEMENT PRACTICES FOR EROSION AND SEDIMENT CONTROL SUCH AS BUT NOT LIMITED TO INSTALLING FILTER CLOTHS ACROSS MANHOLE/CATCHBASIN LIDS TO PREVENT SEDIMENTS FROM ENTERING STRUCTURES AND INSTALL AND MAINTAIN A LIGHT DUTY SILT FENCE BARRIER AS REQUIRED.
  - 2) THE CONTRACTOR SHALL PLACE FILTER BAGS UNDER THE CATCHBASIN AND MANHOLE GRATES FOR THE DURATION OF CONSTRUCTION AND WILL REMAIN IN PLACE DURING ALL PHASES OF CONSTRUCTION.
  - 3) SILT FENCING FOR ENTIRE PERIMETER OF SITE, SHALL BE UTILIZED TO CONTROL EROSION FROM THE SITE DURING CONSTRUCTION.
  - 4) THE CONTRACTOR ACKNOWLEDGES THAT FAILURE TO IMPLEMENT EROSION AND SEDIMENT CONTROL MEASURES MAY BE SUBJECT TO PENALTIES IMPOSED BY ANY APPLICABLE REGULATORY AGENCY.
  - 5) PROVIDE MUD MATS AT ALL CONSTRUCTION ACCESS POINTS TO MINIMIZE SEDIMENT TRANSPORT OFFSITE.
  - 6) EROSION AND SEDIMENT CONTROL MEASURES MAY BE MODIFIED IN THE FIELD AT THE DISCRETION OF THE CITY OF OTTAWA SITE INSPECTOR OR CONSERVATION AUTHORITY.

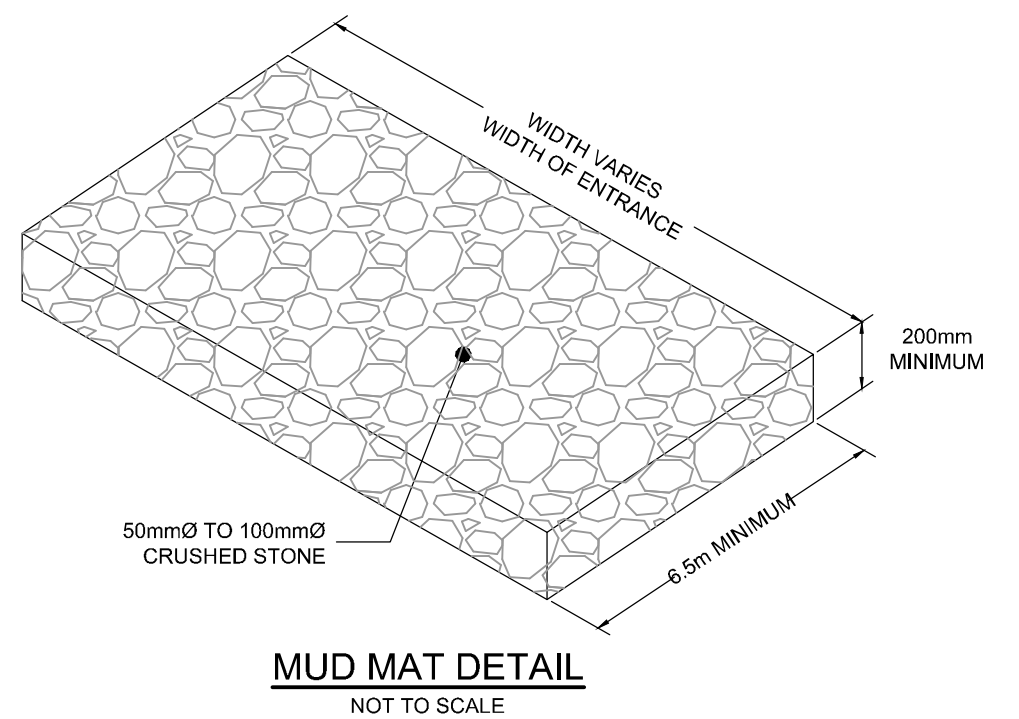
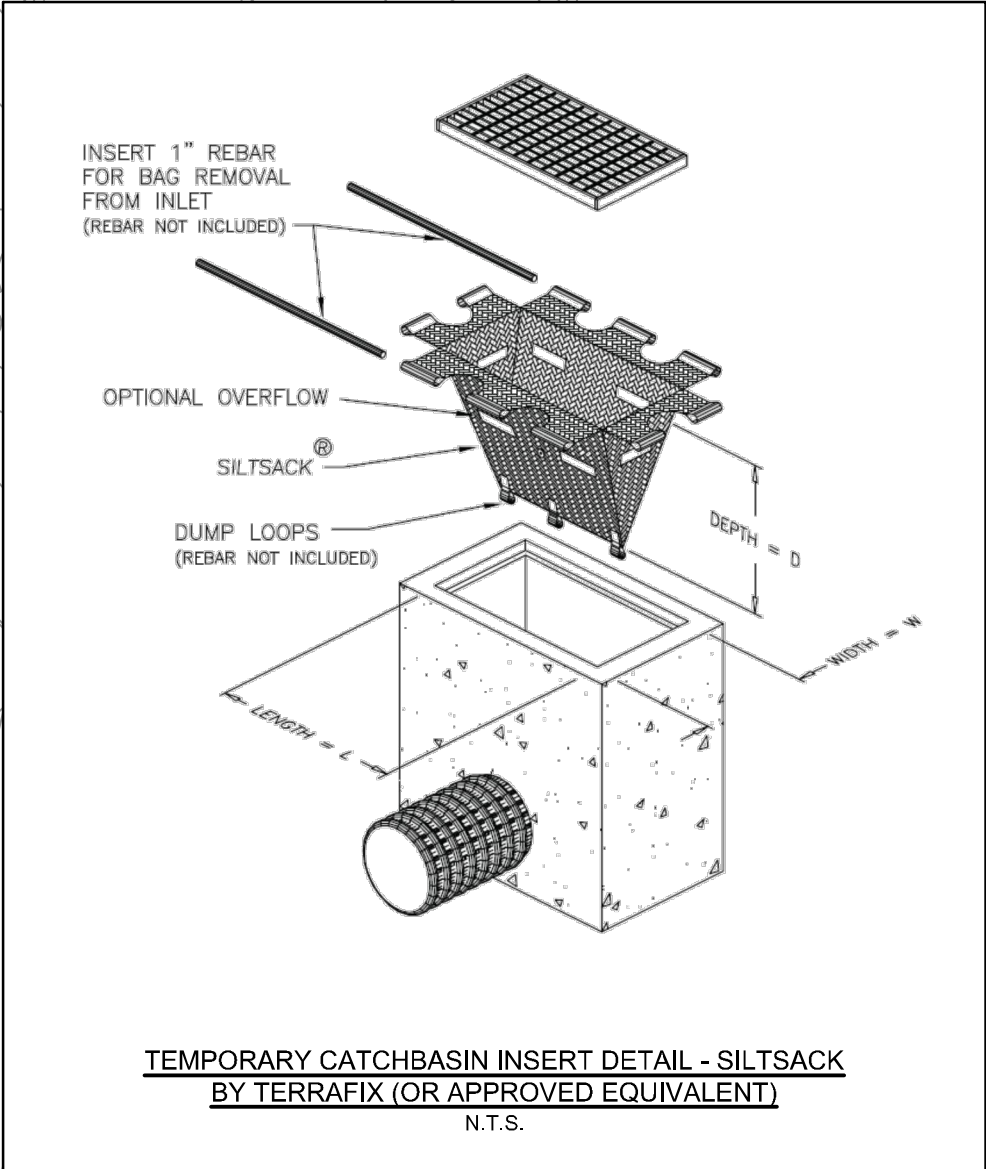

**NOTE:**  
THE POSITION OF ALL POLE LINES, CONDUITS, WATERMANS, SEWERS AND OTHER UNDERGROUND AND OVERGROUND UTILITIES AND STRUCTURES IS NOT NECESSARILY SHOWN ON THE CONTRACT DRAWINGS, AND WHERE SHOWN, THE ACCURACY OF THE POSITION OF SUCH UTILITIES AND STRUCTURES IS NOT GUARANTEED. BEFORE STARTING WORK, DETERMINE THE EXACT LOCATION OF ALL SUCH UTILITIES AND STRUCTURES AND ASSUME ALL LIABILITY FOR DAMAGE TO THEM.

No.	REVISION	DATE	BY
5.	UPDATED PER CITY NAVAN ROAD WIDENING	APR/22/2024	GJM
4.	UPDATED PER CITY COMMENTS	FEB/08/2024	GJM
3.	UPDATED PER CITY COMMENTS	NOV/21/2023	GJM
2.	UPDATED PER CITY COMMENTS	SEPT 15/23	GJM
1.	ISSUED FOR SPA	APR 26/23	GJM

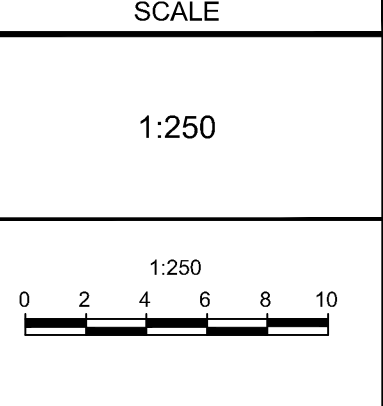

DESIGN: ARM  
CHECKED: GJM  
DRAWN: ARM  
CHECKED: GJM  
APPROVED: GJM

**A.R. MESTWARP**  
10221604  
PROVINCE OF ONTARIO

**G.J. MacDONALD**  
107024  
PROVINCE OF ONTARIO

**NOVATECH**  
Engineers, Planners & Landscape Architects  
Suite 200, 240 Michael Cowpland Drive  
Ottawa, Ontario, Canada K2M 1P6  
Telephone: (613) 254-9643  
Facsimile: (613) 254-5867  
Website: www.novatech-eng.com

LOCATION  
CITY OF OTTAWA  
3080 NAVAN ROAD (RHYTHM APARTMENTS)

DRAWING NAME  
**EROSION AND SEDIMENT CONTROL PLAN**

PROJECT No.: 122180  
REV # 5  
DRAWING No.: 122180-ESC

M:\2024\122180\CAD\Civil\122180-ESC.dwg, ESC, Feb 08, 2024, - 2:11pm, amestwarp

D07-12-23-0047