

451 Smyth Road

University of Ottawa

Advanced Medical Research Centre (AMRC)

Zoning Confirmation Report

Minor Zoning By-law Amendment & Site Plan Control Applications

April 18, 2024



uOttawa



PARKIN
ARCHITECTS LIMITED

451 Smyth Road
University of Ottawa
Advanced Medical Research Centre (AMRC)

Zoning Confirmation Report

Minor Zoning By-law Amendment & Site Plan Control Applications

April 18, 2024

Prepared For:

George Zigoumis
Senior Director, Asset Management, Planning & Real Estate, Facilities
University of Ottawa
75 Laurier Avenue East
Ottawa, ON K1N 6N5
T: 613-791-1821
E: GZigoumi@uOttawa.ca

Prepared By:

WSP Canada Inc.
2611 Queensview Drive, Suite 300, Ottawa, ON, K2G 8K2

Nadia De Santi, MCIP, RPP
Practice Lead
T: 613-690-1114
E: Nadia.De-Santi@wsp.com

Jill MacDonald, MCIP, RPP
Senior Planner
T : 613-690-3936
E : Jill.MacDonald@wsp.com

SIGNATURES

PREPARED BY



Nadia De Santi, MCIP, RPP
Practice Lead



Jill MacDonald, MCIP, RPP
Senior Planner

This Zoning Confirmation Report was prepared by WSP Canada Inc. (“WSP”) for PCL Construction (“Client”) on behalf of the University of Ottawa (“uOttawa”) in accordance with the agreement between WSP and the Client. This Zoning Confirmation Report is based on information provided to WSP which has not been independently verified.

The disclosure of any information contained in this Report is the sole responsibility of the Client. The material in this Report, accompanying documents and all information relating to this activity reflect WSP’s judgment in light of the information available to us at the time of preparation of this Report. Any use which a third party makes of this Report, or any reliance on or decisions to be made based on it, are the responsibility of such third parties. WSP accepts no responsibility for damages, if any, suffered by a third party as a result of decisions made or actions based on this Report.

WSP warrants that it performed services hereunder with that degree of care, skill, and diligence normally provided in the performance of such services in respect of projects of similar nature at the time and place those services were rendered. WSP disclaims all other warranties, representations, or conditions, either express or implied, including, without limitation, warranties, representations, or conditions of merchantability or profitability, or fitness for a particular purpose.

This Standard Limitations statement is considered part of this Report.

1 Introduction

WSP was retained by PCL Construction on behalf of the University of Ottawa (“uOttawa”) to prepare a Zoning Confirmation Report in support of the Minor Zoning By-law Amendment and Site Plan Control applications for the lands municipally known as 451 Smyth Road (the “Site”) in the City of Ottawa. The requested Minor Zoning By-law Amendment and Site Plan Control applications (the “Applications”) would permit the development of a six-storey state-of-the-art medical research facility, the Advanced Medical Research Centre (AMRC), as an addition to the existing Roger Guindon Hall, which is also owned and operated by uOttawa and is part of the Ottawa Health Science Complex (OHSC).

This Zoning Confirmation Report has been prepared to provide a detailed review to determine compliance of the proposed AMRC development with the City of Ottawa Zoning By-law 2008-250 (September 8, 2021 Consolidation). This review is based on the Site Plan prepared by Parkin Architects, dated April 10, 2024.

The Zoning Confirmation Report is set up as follows:

- **Section 2** includes the Zoning Confirmation Checklist, including Project Information and the Zoning Review, which provides a full review of the applicable zoning requirements and identifies any areas of non-compliance;
- **Section 3** includes the Draft List of Requested Relief, which details the list of non-compliant zoning items identified in Section 2 of this Report, as well as the draft Zoning Schedule;
- **Appendix A** includes the Site Plan, prepared by Parkin Architects (dated April 10, 2024); and
- **Appendix B** includes the draft Zoning By-law Amendment text and Schedule.

It is noted that the information in the Zoning Review and Draft List of Requested Relief is also included in the Planning Rationale, prepared by WSP (dated April 10, 2024), which is included under separate cover.

2 Zoning Confirmation Checklist

2.1 Project Information

The site is municipally known as 451 Smyth Road in the City of Ottawa and is part of uOttawa’s Alta Vista Campus within the Ottawa Hospital General Campus, which is located in Ward 18 (Alta Vista). The portion of the site being redeveloped (“AMRC Site”) is located at the northwestern limit of Ring Road and north of Smyth Road. The AMRC site is irregular in shape and has a frontage of approximately 180 metres (590.55 ft) along Ring Road and an area of approximately 20.48 hectares (50.61 acres).

Figure 2-1 illustrates the site and AMRC site’s location and approximate boundaries. The property at 451 Smyth Road (shown in blue in **Figure 2-1**) is subject to the Minor Zoning By-law Amendment and Site Plan Control applications.

Figure 2-1: Site Location

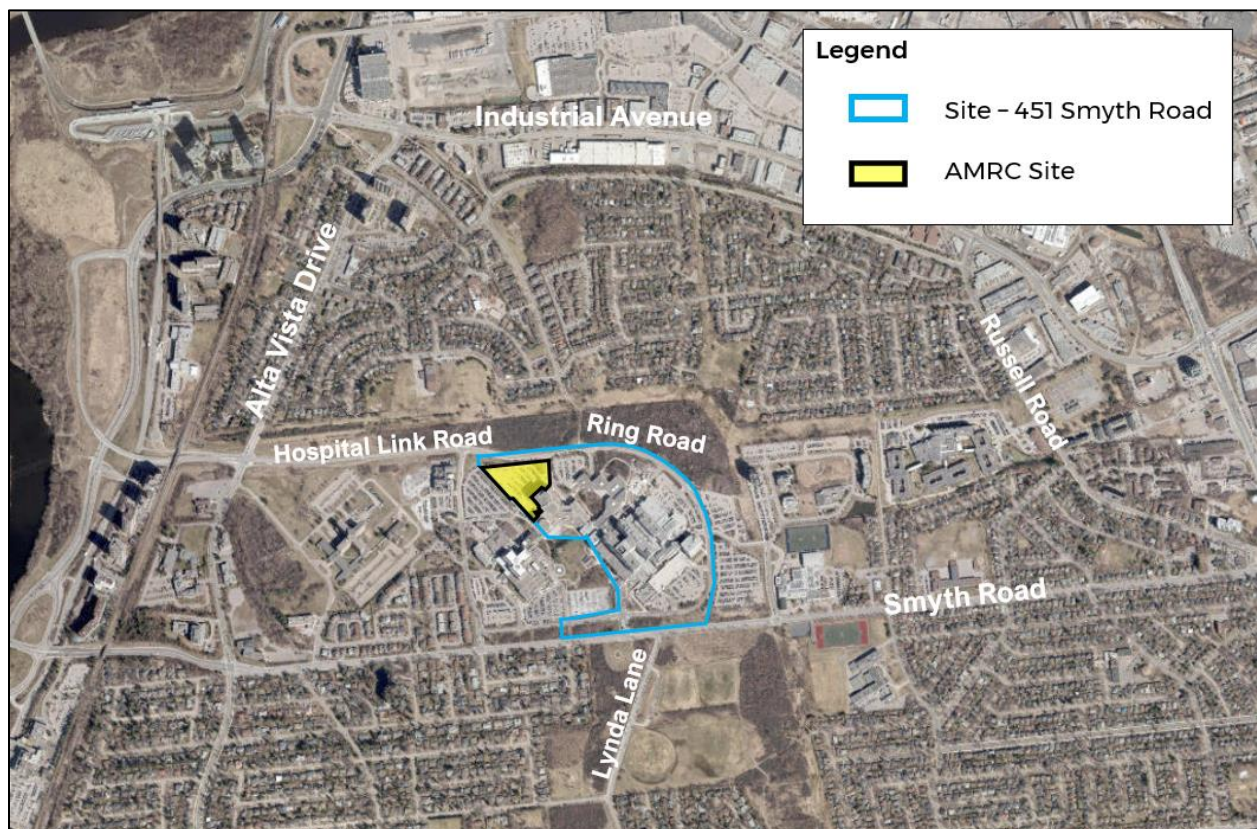

The Project Information is summarized in **Table 2-1**.

Table 2-1: Project Information - 451 Smyth Road (AMRC)

Project Information			
Review Date:	April 18, 2024	Official Plan Designation:	Outer Urban Transect, Neighbourhood
Municipal Address(es):	451 Smyth Road Note: Subordinate addresses for 451 Smyth Road - 501, 503, 505, 507 Smyth Road	Legal Description:	Site plan
Scope of Work:	A new Advanced Medical Research Centre by the University of Ottawa, a six-storey medical research facility (i.e., post-secondary educational institution) with a gross floor area of approximately 13,726.17 m ² (147,747.26 ft ²).		
Existing Zoning Code:	Major Institutional Zone, Urban Exception 402, Floor Space Index 1.5, Schedule 144 (I2[402] F(1.5) S144)	By-law Number:	2008-250
Schedule 1 / 1A Area:	Outer Urban / Inner Suburban	Overlays Applicable:	N/A

2.2 Zoning Confirmation Checklist

The proposed AMRC is proposed to be located adjacent to the existing Roger Guindon Hall (RGN) at 451 Smyth Road, as part of the Ottawa Health Science Complex (OHSC). Under the City of Ottawa Comprehensive Zoning By-law 2008-250 (Consolidation September 8, 2021), the site is zoned **Major Institutional Zone, Urban Exception 402, Floor Space Index 1.5, Schedule 144 (I2[402] F(1.5) S144)**, as shown in **Figure 2-2**.

Properties immediately adjacent to the site are zoned Environmental Protection Zone (EP), Parks and Open Space Zone (OP), Parks and Open Space Zone, Urban Exception 313 (O1[313]) to the north, Residential Fourth Density Zone, Urban Exception 897, Schedule 144 (R4N[897] S144) and Parks and Open Space Zone, Urban Exception 402, Schedule 144 (O1[402] S144) to the east. Properties to the south are zoned Parks and Open Space Zone (O1), Parks and Open Space Zone, Subzone C (O1C) and Residential First Density Zone, subzone GC (R1GG) and Major Institutional Zone, Urban Exception 370, Floor Space Index 1.5, (I2[370] F(1.5)) to the west.

Figure 2-2: Site Zoning (geoOttawa, 2024)

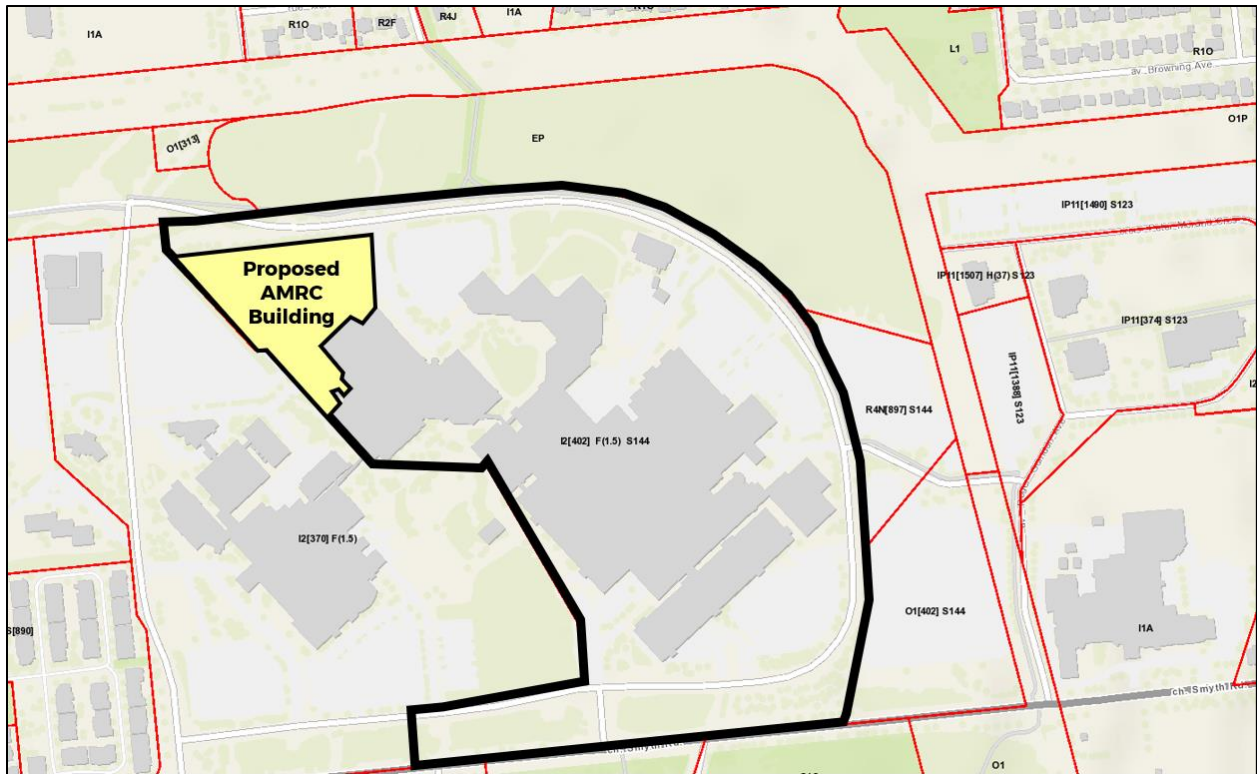

2.2.1 Zoning Provisions

The general purpose of the I2 Zone is to:

- ensure that major institutional uses such as hospitals, colleges and universities are located at appropriate locations within areas designated as General Urban Area, Central Area and Mixed Use Centre in the Official Plan;
- ensure that these large scale, high traffic generating institutions locate only on large parcels of land, with direct access to an arterial road and near rapid transit stations;
- impose regulations which ensure that the size and intensity of these uses is compatible with adjacent uses; and
- permit minor institutional uses and provide for a range of ancillary service uses.

The I2 Zone permits a number of non-residential uses, including a post secondary educational institution, community health and resource centre, emergency service, hospital, parking garage, and parking lot. The proposed AMRC will include Animal Care and Veterinary Services, an Innovation Hub, and Faculty of Medicine Labs associated with uOttawa, and **can collectively be considered a post-secondary educational institution.**

The City's Zoning By-law defines "**post-secondary educational institution**" as a "university which means a place of higher education, which has a body of teachers and students on the premises, and that offers instruction at the undergraduate level, post-graduate level, or both, and which is empowered by law to grant a degree upon the successful completion of a prescribed course of study."

At the Phase 1 pre-application consultation meeting with City staff on August 23, 2023, City staff confirmed that the proposed AMRC facility will function as a post-secondary education institution. The City further confirmed in the initial Feedback Form dated August 25, 2023 that adding "research and development centre" as a proposed use for the site will not be required.

In addition, **Urban Exception 402 applies to the Site** and includes the following provisions:

- Minimum front yard setback is 46 metres;
- No parking is permitted within the front yard setback; and
- Parking spaces provided within Area A on Schedule 144 may be used to fulfill parking requirements for development occurring subsequent to February 29, 2004 at 501 Smyth Road.

Schedule 144 applies to the Site and illustrates the properties addressed 501 Smyth Road (i.e., 451 Smyth Road) and 599 Smyth Road, as well as Lot Line B, as shown in **Figure 2-3**. It is noted that 599 Smyth Road is owned by the City.

Figure 2-3: City of Ottawa Zoning By-law 2008-250 - Schedule 144

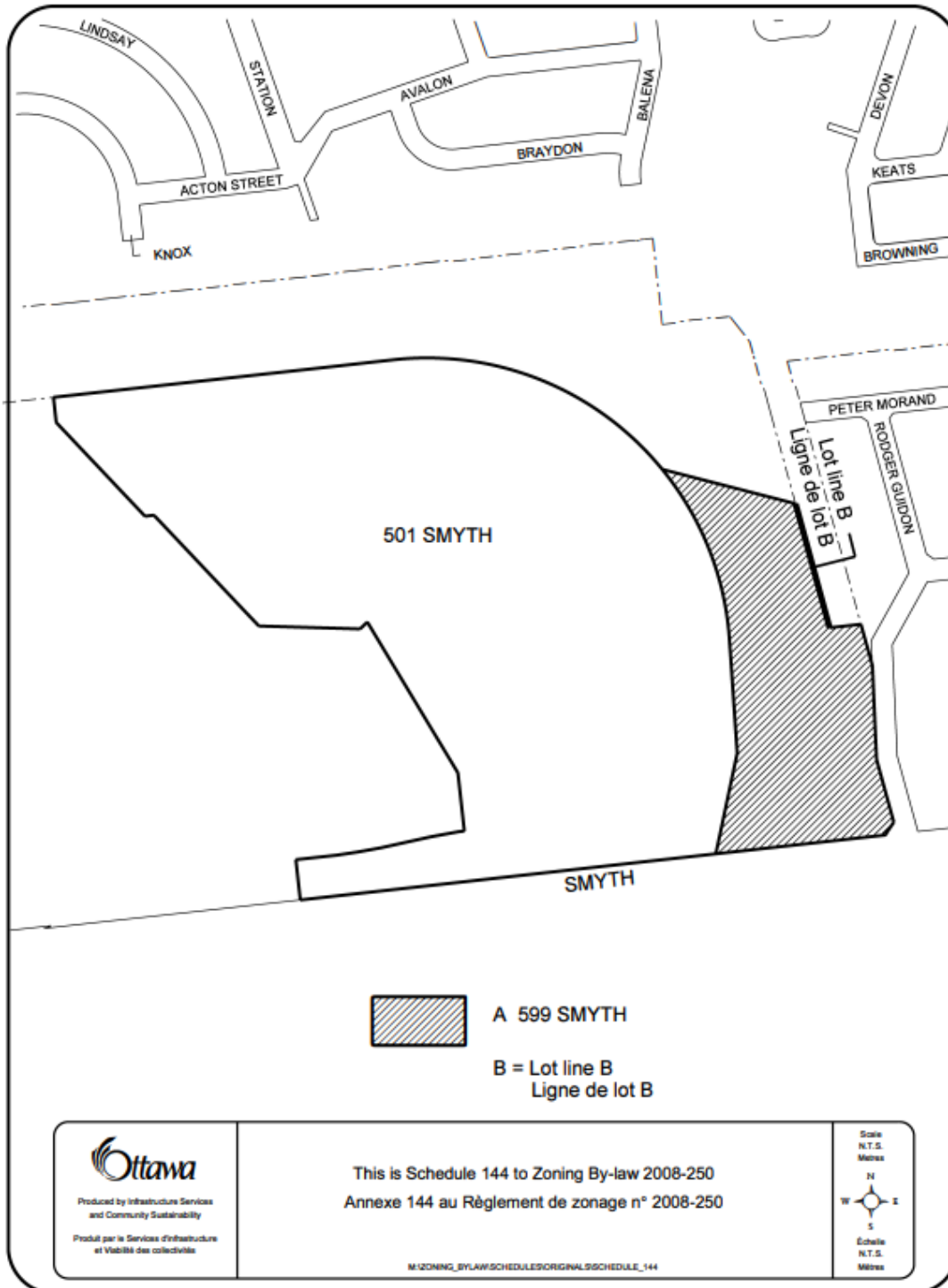

Table 2-2 provides a detailed zoning compliance analysis of how the proposed AMRC development at 451 Smyth Road meets the Zoning By-law provisions for the I2 Zone. The review in **Table 2-2** is based on the Site Plan, prepared by Parkin Architects (dated April 18, 2024). The Site Plan is included as **Appendix A** to this Report.

Table 2-2: Zoning Compliance for Major Institutional Zone (I2) - 451 Smyth Road

Zoning Provision	Requirement -	Calculation (if applicable)	Compliance (Yes or No)
Zone Requirement - I2 Zone (Table 171)			
Minimum lot width - Sec. 171, Table 171(1)	No minimum	N/A	Yes - 257.13 m
Minimum lot area - Sec. 171, Table 171(2)	No minimum	N/A	Yes - Lot area (451 Smyth Road): 204,834.211 m ²
Minimum front yard setback - Part 15 - Exceptions, Urban Exception 402	46 m	N/A	Yes - 364.54 m
Minimum rear yard setback- Sec. 171, Table 171(4)	7.5 m	N/A	Yes - 117.79 m
Minimum interior side yard setback - Sec. 171, Table 171(5)	7.5 m	N/A	Yes - 34.79 m
Minimum corner yard setback- Sec. 171, Table 171(6)	7.5 m	N/A	Yes - 103.7 m
Maximum building height - Sec. 171, Table 171(7)	Within 12 m of an R1, R2, or R3 Zone: 15 m Other cases: no maximum	N/A	Yes - 39.1 m (6 storeys + mechanical penthouse & atrium roof)
Minimum width of landscaped area along all lot lines - Sec. 171, Table 171(8)	3 m	N/A	No - Landscaped area/buffer is not provided along the rear lot line of 451 Smyth Road as Ring Road and internal roads cross the rear property line of 451 Smyth Road.
Maximum floor space index - FSI 1.5	1.5	FSI (Entire site at 451 Smyth):	Yes - Total FSI (Proposed AMRC + existing buildings including RGN, TOH, Oasis): 0.69

Zoning Provision	Requirement -	Calculation (if applicable)	Compliance (Yes or No)
		Site area: 204,834.21 m ² Total GFA = 13,726.17 m ² (Proposed AMRC at 451 Smyth) + 128,023 m ² (Existing RGN, TOH and Oasis buildings on site) = 141,749.17 m² FSI = Total GFA / Lot Area = 141,749.17 m ² / 204,834.21 m ² = 0.69	

2.2.2 Provisions for Accessory Uses, Buildings or Structures

The Zoning By-law contains provisions for accessory uses, building or structures, as set out in **Table 2-3**. There is a new generator proposed to the west of AMRC building as shown on the Site Plan, which is an accessory structure.

Table 2-3: Provisions for Accessory Uses, Building or Structures

Zoning Provision	Requirement (IV - All other zones)	Calculation (if applicable)	Compliance (Yes or No)
Minimum required setback from a front lot line, Sec. 55, Table 55(1)	Same as required for principal building - 46 m	N/A	Yes - 365 m
Minimum Required Setback from a Corner Side Lot Line or a Rear Lot Line abutting a street, Sec. 55, Table 55(2)	0 m	N/A	N/A

Zoning Provision	Requirement (IV - All other zones)	Calculation (if applicable)	Compliance (Yes or No)
Minimum Required Setback from an Interior Side Lot Line or Rear Lot Line not abutting a street, Sec. 55, Table 55(3)	(e) Other accessory buildings or structures, or situations not otherwise specified above. (ii) Not abutting a residential zone - 0 m.	N/A	Yes - 4.387 m (New generator)
Minimum Required Distance from Any Other Building Located on the same lot, except for a hot tub, Sec. 55, Table 55(4)	0 m	N/A	N/A - No minimum distance required.
Maximum Permitted Height, Sec. 55, Table 55(5)	6 m	N/A	Yes - 4.5 m
Maximum Permitted Size, Sec. 55, Table 55(6)	No restriction	N/A	Yes - 3.5 m X 12 m
Maximum Number of Accessory Buildings Permitted on a lot, Sec. 55, Table 55(7)	No restriction	N/A	Yes - One (1) accessory structure (the new generator) is proposed.

2.2.3 Permitted Projections Above the Height Limit and Permitted Projections into Required Yards Provisions

The Zoning By-law contains provisions for permitted projections above the height limit and permitted projections into required yards, as set out in **Table 2-4**. There are no proposed projections into required yards for the proposed AMRC development at 451 Smyth Road.

Table 2-4: Provisions for Permitted Projections Above Height Limit / into Required Yards

Zoning Provision	Requirement	Calculation (if applicable)	Compliance (Yes or No)
Permitted projections above the height limit – Sec. 64	<p>Except in the case of buildings or structures located within the area shown on Schedules 11 to 88 (Central Area Height Schedules), the maximum height limits do not apply to the structures listed below or to any other similar structures that may require a height in excess of maximum height limits in order to serve their intended purpose, unless otherwise specified in the by-law and provided these structures are erected only to such height or area as is necessary to accomplish the purpose they are to serve and that is necessary to operate effectively and safely:</p> <ul style="list-style-type: none"> – Mechanical and service equipment penthouse, elevator or stairway penthouse 	N/A	<p>Yes – Mechanical room above Level 6 = 6 m high + Atrium = 3.6 m Elevator overrun = currently unknown</p> <p>There is no maximum height limit.</p>
Chimney, chimney box and fireplace box, Sec. 65, Table 65(1)	1 m, but not closer than 0.6 m to a lot line	N/A	N/A
Eaves, eaves-troughs and gutters, Sec. 65, Table 65(2)	1 m, but not closer than 0.3 m to a lot line	N/A	N/A
Ornamental elements such as sills, belt courses, cornices, parapets and	0.6 m, but not closer than 0.6 m to a lot line	N/A	N/A

Zoning Provision	Requirement	Calculation (if applicable)	Compliance (Yes or No)
pilasters, Sec. 65, Table 65(3)			
Canopies and awnings, Sec. 65, Table 65(4)	(b) All other buildings including a low-rise apartment dwelling and mid-high-rise apartment dwelling: <ul style="list-style-type: none"> i) a distance equal to ½ the depth of a front, rear or corner side yard but not closer than 0.6 m to a lot line, and ii) 1.8 m into an interior side yard, but not closer than 0.6 m to a side lot line 	N/A	N/A – Proposed entrance canopies will not project into required yards.
Fire escapes, open stairways, stoop, landing, steps and ramps – Sec. 65, Table 65(5)	(b) Other features: <ul style="list-style-type: none"> i) where at or below the floor level of the first floor: 1. in the case of the interior side yard or rear yard: no limit, and ii) other cases: 1. In the case of any yard: 1.5m, but not closer than 1 m to a lot line 	N/A	N/A
Covered or uncovered balcony, porch, deck, platform, and verandah, with a maximum of two enclosed sides, excluding those covered by canopies and awnings, Sec. 65, Table 65(6)	a) uncovered, unenclosed features such as decks or platforms where the walking surface is not higher than 0.6 m above adjacent grade: <ul style="list-style-type: none"> (i) in the interior side yard and rear yard: no limit (ii) in the front yard and corner side yard – the greater of 2 m or 50% of the required front yard or corner side yard, but no closer than 1m to a property line 	N/A	N/A

Zoning Provision	Requirement	Calculation (if applicable)	Compliance (Yes or No)
	c) In all other cases: 2 metres, but no closer than 1 metre from any lot line.		
Bay window where window faces a lot line, Sec. 65, Table 65(7)	1 m, but not closer than 1.2 m from a lot line	N/A	N/A
Air conditioner condenser, heat pump or <u>similar equipment</u>, Sec. 65, Table 65(8)	III) For All Other Buildings (i.e., non-residential) (b) Other cases – no restriction.	N/A	N/A – No requirement. Interior yard does not abut a residential use.
Exit stairs – Sec. 161(13)(m)	Exit stairs providing required egress under the Building Code may project a maximum of 2.2 metres into the required rear yard.	N/A	Yes

2.2.4 Parking Provisions

The Zoning By-law contains provisions for parking, as set out in **Table 2-5**. The site is within Area B on Zoning By-law Schedule 1A, as illustrated in **Figure 2-4**.

For the purposes of applying the provisions of Section 103 - Maximum Limit on Number of Parking Spaces Near Rapid Transit Stations, the site is located in Area B: Inner Urban on Schedule 1 of the Zoning By-law, as illustrated in **Figure 2-4**. Applicable provisions are identified in **Table 2-5**. **The site is not within 300 m of an existing rapid transit station in Schedule 2A or 2B.**

Figure 2-4: Schedule 1A - Areas for Minimum Parking Space Requirements, City of Ottawa Zoning By-law (via geoOttawa, 2024)



Figure 2-5: Schedule 1 - Boundaries of the Central, Inner Urban, Suburban and Rural Areas (Excerpt), City of Ottawa Zoning By-law (via geoOttawa, 2024)



Table 2-5: Parking and Loading Space Provisions

Zoning Provision	Requirement	Calculation (if applicable)	Compliance (Yes or No)
Schedule 1A	The Site is designated as Area B “Inner Urban” in Schedule 1A of City of Ottawa Zoning By-law No. 2008-250.	N/A	N/A
Schedule 2A and 2B	The Subject Site is not within 300 metres of a rapid transit station in Schedule 2A or Schedule 2B.	N/A	N/A
Minimum Parking Space Rates – Sec. 101, Table 101	<p><u>Area B (Schedule 1A):</u></p> <p>Proposed Use (AMRC): Post Secondary Educational Institution: 0.75 per 100 m² of gross floor area</p> <p>Other existing uses on-site (451 Smyth Road): Hospital: 1.4 per 100 m² of gross floor area Daycare: 2 per 100 m² of gross floor area</p>	<p>451 Smyth Road (All uses – proposed AMRC and existing):</p> <p>GFA: Proposed AMRC = 13,726.17 m² Existing RGN = 27,387 m² Existing TOH = 124,985 m² Existing Oasis = 809.9 m²</p> <p>Required Parking:</p> <p>Proposed AMRC only: = 0.75 * (13,726.17/100) = 0.75 * 137.26 = 102.94 = 103 (rounded)</p> <p>Proposed AMRC + Existing RGN: = 0.75 * ((13,726.17 + 27,387)/100) = 0.75 * (411.1317) = 308</p>	<p>Yes – The existing parking lot with 361 parking spaces will be demolished. As part of the AMRC redevelopment, 126 additional new spaces will be provided. See below:</p> <p>Proposed Parking (Proposed AMRC building only):</p> <p>= 120 (new parking spaces) + 6 (new service spaces) = 126 spaces</p> <p>Total Proposed Parking (451 Smyth Road): = 126 + (2,098 (existing) – 361 (removed from RGN Parking Lot H)) = 126 + 1,737</p>

Zoning Provision	Requirement	Calculation (if applicable)	Compliance (Yes or No)
		<p>Existing TOH: $= 1.4 * (99,988/100)$ $= 1,399.83$</p> <p>Existing Oasis: $= 2 * (648/100)$ $= 12.96$</p> <p>Total Required Parking (451 Smyth Road): $= 308 + 1,399.83 + 12.96$ $= 1,720.79$ $= 1,721$ (rounded)</p> <p>Additional notes: Existing Parking at 451 Smyth Road: $= 1,737$ spaces</p> <p>Parking spaces to be removed from the existing RGN Parking Lot H (361 existing parking spaces): $= 361$ spaces</p>	<p>= 1,863 parking spaces</p>
Urban Exception 402	No parking is permitted within the front yard setback.	N/A	Yes - No parking is proposed to be located within the front yard setback as part of the proposed AMRC development. It is noted the front yard setback is taken from Smyth Road.
Minimum visitor parking spaces - Sec. 102, Table 102	None required for the proposed use.	N/A	While none are required, visitors may use any of the parking spaces serving for the proposed building.

Zoning Provision		Requirement	Calculation (if applicable)	Compliance (Yes or No)
Dimension requirements for a motor vehicle parking space - Sec. 106(1)	(a) Width	Minimum width of 2.6 m; maximum width of 3.1 m.	N/A	Yes - Parking spaces will be 5.2 m x 2.6 m.
	(b) Length	5.2 m	N/A	
Minimum Driveway Width to Parking Lot - Sec. 107(1)		(a) (i) three metres for a single traffic lane;	N/A	Yes - 3 m.
Minimum Required Aisle Width - Table 107		6.7 m for angle of parking that is 90 degrees	N/A	Yes - 6.7 m.
Accessible Parking Spaces (Part C - Parking required for persons with disabilities, Section 111, By-law no. 2017-301)		AMRC site only: For a public parking area that contains 100-199 parking spaces, 2 accessible parking spaces are required.	N/A	Yes - 6 accessible parking spaces will be provided for the proposed AMRC building.
City of Ottawa Accessibility Design Standards - Section 3.1.3(f)		Minimum width of 3400 mm for "Type A" wide van accessible spaces	N/A	Yes - 6 "Type A" wide van accessible spots will be provided.
		Minimum width of 2400 mm for "Type B" standard parking spaces		
City of Ottawa Accessibility Design Standards - Section 3.1.3(g)		Provide an access aisle adjacent and parallel to each accessible parking space: <ul style="list-style-type: none"> i. 1500 mm wide (minimum; ii. extend the full length of the space; 	N/A	Yes - 1.5 m access aisle is provided for accessible parking spaces.

Zoning Provision	Requirement	Calculation (if applicable)	Compliance (Yes or No)
	iii. clearly indicated by high colour contrast diagonal pavement markings; iv. where two accessible parking spaces are provided adjacent to each other, they may share an access aisle; v. connect with adjacent accessible path of travel and centre curb ramp on access aisle		
Outdoor loading and refuse collection areas within a parking lot - Sec. 110(3)	Requirements: - 9 m from a lot line abutting a public street - 3 m from any other lot line Screened from view by an opaque screen with a min. height of 2 m	N/A	Yes - 18.864 m from interior lot line (existing waste collection area). A 2 m high opaque screen is provided.
Landscaping Provisions for Parking Lots - Sec. 110	Minimum 15% of the parking lot must be provided as perimeter or interior landscape area comprised of:	15% of parking lot area: = $0.15 \times (24,625.76 \text{ m}^2)$ = $3,693.86 \text{ m}^2$	Yes - 17% of the parking lot area will be landscaped - $4,186.38 \text{ m}^2$

Zoning Provision	Requirement	Calculation (if applicable)	Compliance (Yes or No)
	<p>a) a landscaped buffer must be provided between the perimeter of the parking lot and a lot line in accordance with Table 110. A driveway may cross the landscaped buffer; and</p> <p>b) in addition to the landscaped buffer, interior landscaping may be provided including various landscaped is, landscaped medians, pedestrian pathways or public plazas to meet the minimum 15% requirement.</p>		
<p>Minimum required width of a landscaped buffer of a parking lot – Sec. 110, Table 110</p>	<p>For a parking lot containing 100 or more parking spaces:</p> <p>(a) abutting a street: 3 m</p> <p>(b) not abutting a street: 3 m</p>	<p>N/A</p>	<p>No – 1.045 m landscape buffer between new uOttawa parking lot and internal access street.</p>
<p>Minimum number of bicycle parking spaces – Sec. 111(2), Table 111A</p>	<p>Proposed Use (AMRC):</p> <p>(e) post secondary educational institution</p> <p>1 per 250 m² of gross floor area</p>	<p>451 Smyth Road (All uses – proposed AMRC and existing):</p> <p>GFA: Proposed AMRC: = 13,726.17 m²</p> <p>Required Bicycle Parking:</p>	<p>Yes – 222 new bicycle parking spaces are proposed for the AMRC building.</p> <p>467 existing bicycle parking spaces serve the existing RGN, TOH and Oasis buildings. 20 spaces</p>

Zoning Provision	Requirement	Calculation (if applicable)	Compliance (Yes or No)
	<p>Other existing uses on-site (451 Smyth Road):</p> <p>(e) daycare: 1 per 250 m² of gross floor area</p> <p>(g) hospital: 1 per 1,000 m² of gross floor area</p>	<p>GFA: Proposed AMRC = 13,726.17 m² Existing RGN = 27,387 m² Existing TOH = 124,985 m² Existing Oasis = 809.9 m²</p> <p>Proposed AMRC only: = 1 * (13,726.17/250) = 54.90 = 55 (rounded)</p> <p>Proposed AMRC + Existing RGN: = 1 * ((13,726.17 + 27,387)/250) = 164.45 = 164 (rounded)</p> <p>Existing TOH: = 1 * (99,988/1000) = 99.98 spots = 100 (rounded)</p> <p>Existing Oasis: = 1 * (648/250) = 2.59 = 3 (rounded)</p> <p>Total Required Bicycle Parking (451 Smyth Road): = 164 + 100 + 3 = 267 bicycle parking spaces</p>	<p>will be removed as result of construction works.</p> <p>A total of 699 bicycle spaces will be provided across the entire 451 Smyth Road site.</p>

Zoning Provision	Requirement	Calculation (if applicable)	Compliance (Yes or No)
		Additional Notes: Existing Bicycle Parking serving the existing RGN, TOH and Oasis buildings = 497	
Bicycle parking space location - Sec. 111 (3)	Must be located on the same lot as the use or building for which it is provided	N/A	Yes - Bicycle parking spaces are proposed on the same lot.
Bicycle parking space location - Sec. 111 (4)	Must be located in order to provide convenient access to main entrances or well-used areas	N/A	Yes - Bicycle parking spaces are proposed to be located to building entrances.
Bicycle parking spaces location in landscaped area - Sec. 111 (7)	Max. of 50% or 15 spaces, whichever is greater	36/222 spots in landscaped area = 16.2% =26% (rounded)	Yes - 16% of bicycle parking spaces are located in landscaped area.
Minimum bicycle parking space dimensions - Sec. 111 (8), Table 111B	(a) Horizontal: Width: 0.6 m Length: 1.8 m	N/A	Yes - 1.8 m X 0.6 m
Minimum bicycle parking aisle width - Sec. 111 (9)	A bicycle parking space must have access from aisle having a min. width of 1.5 m	N/A	Yes - 1.5 m
Minimum number of vehicle loading spaces required - Sec. 113, Table 113A	a) Post secondary educational institution: 25,000 m ² and over: 3 loading spaces	Total GFA (451 Smyth Road): = 13,726.17 m ² (Proposed AMRC at 451 Smyth) + 128,023 m ² (Existing RGN, TOH and Oasis buildings on site) = 141,749.17 m ²	Yes - Three (3) new loading docks (bays) are proposed at the proposed AMRC, and two (2) loading existing docks at RGN building noted on the Site Plan.
Minimum width of driveway accessing loading space - Sec. 113, Table 113B(a)	(i) - Single traffic lane - 3.5 m (ii) Double traffic lane - 6 m		Yes - 7.077 m

Zoning Provision	Requirement	Calculation (if applicable)	Compliance (Yes or No)
Minimum width of aisle accessing loading space, by angle of loading space - Sec. 113, Table 113B(b)	For a standard space: (i) 45 degrees or less: 5 m (ii) Between 45 degrees and 60 degrees: 6.3 m (iii) 60 degrees to 90 degrees: 9 m	N/A	Yes - 5.169 m
Minimum width of loading space - Sec. 113, Table 113B(c)	Standard Space: 3 m	N/A	Yes - 4.3 m
Minimum length of loading space - Sec. 113, Table 113B(b)	(ii) Other cases: 7 m	N/A	Yes - 9.75 m
Minimum landscaped area of any parking lot - Sec. 110, provision (1)	Except in the case of an industrial zone, a minimum of 15% of the area of any parking lot, whether a principal or an accessory use, must be provided as perimeter or interior landscaped area.		Yes - 22% of the parking lot is landscaped.

3 Draft List of Requested Relief from Zoning

Through the completion of the Zoning Confirmation Checklist in **Section 2.2** of this Report, two (2) areas of non-compliance for the proposed development were identified. These provisions and proposed relief are summarized in **Table 3-1**.

Table 3-1: Draft List of Requested Relief from Zoning

Applicable By-law Section	Requirement	Proposed
Minimum width of landscaped area along all lot lines - Sec. 171, Table 171(8)	3 m	0 m along the rear lot line.
Minimum required width of a landscaped buffer of a parking lot - Sec. 110, Table 110	For a parking lot containing 100 or more parking spaces: (a) abutting a street: 3 m (b) not abutting a street: 3 m	1 m landscape buffer between new uOttawa parking lot and internal access street.

3.1 Minor Zoning By-law Amendment

In order to facilitate the proposed development, a Minor Zoning By-law Amendment to the to the City of Ottawa Zoning By-law 2008-250 is required. The entire property at 451 Smyth Road, including the AMRC development site is currently zoned Major Institutional Zone, Urban Exception 402, Floor Space Index 1.5, Schedule 144 (I2[402] F(1.5) S144). The Minor Zoning By-law Amendment proposes to modify Urban Exception 402 to grant relief from zoning requirements related to landscape buffers and would affect the lands identified as 'Area A' in the Draft Zoning By-law Schedule shown in **Figure 3-3**, and also included as **Appendix B** to this Report.

The amendments to Urban Exception 402 are required because the proposed development at 451 Smyth Road does not meet all the requirements of the I2 Zone in the Zoning By-law.

The requested amendments to Urban Exception 402, firstly include relief from the requirement for a 3 metre landscaped area along all lot lines per Sec. 171, Table 171(8) of the Zoning By-law. The requested reduction in the landscape area to 0 metres along the northern lot line is requested to address existing conditions on-site, as Ring Road and the existing sidewalks on both sides of Ring Road cross the northern property line of 451 Smyth Road, as shown in the Site Plan (**Figure 3-1**).

Additionally, the proposed parking layout for the site is designed to meet uOttawa's program requirements, which are to facilitate access to health and research services in consideration of the overall Ottawa Health Science Complex (OHSC) operations.

Figure 3-1: Northern lot line - 451 Smyth Road

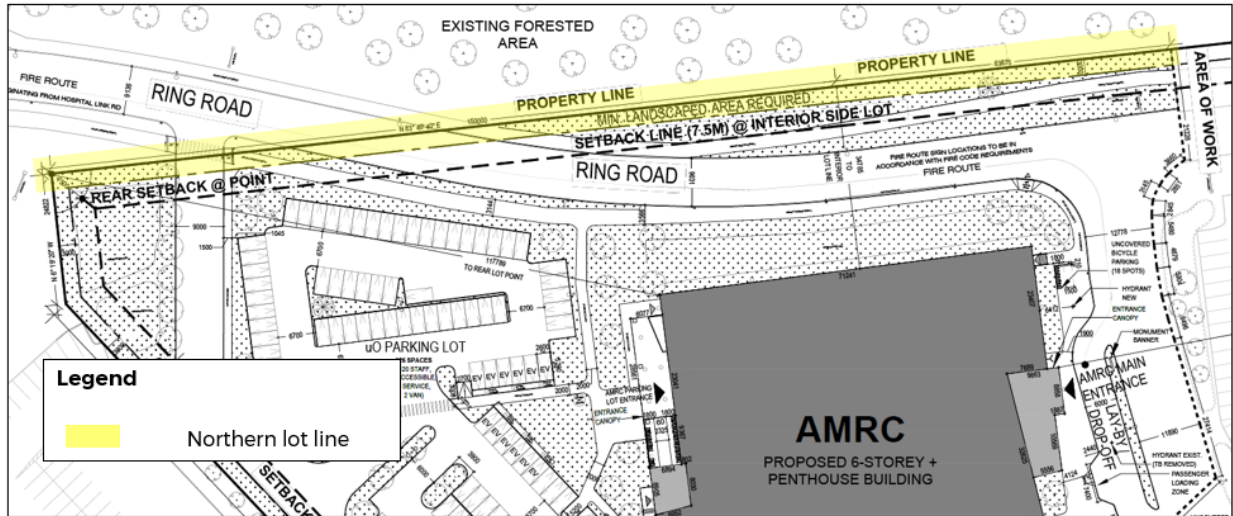

Additionally, a reduction in the minimum required width of a landscaped buffer for a parking lot is being requested. Per Sec. 110, Table 110, for a parking lot containing 100 or more parking spaces, a 3 metre landscaped buffer is required for parking lots abutting a street. A 3 metre landscaped buffer is also required for parking lots which do not abut street. As shown in the Site Plan (**Figure 3-2**), the landscaped buffer at the western edge of the new uOttawa parking lot is proposed to be 1.045 metres. As such, a reduction from 3 metres to 1 metre is requested for the landscaped buffer around the parking lot.

Figure 3-2: Proposed AMRC Parking Lot - 451 Smyth Road

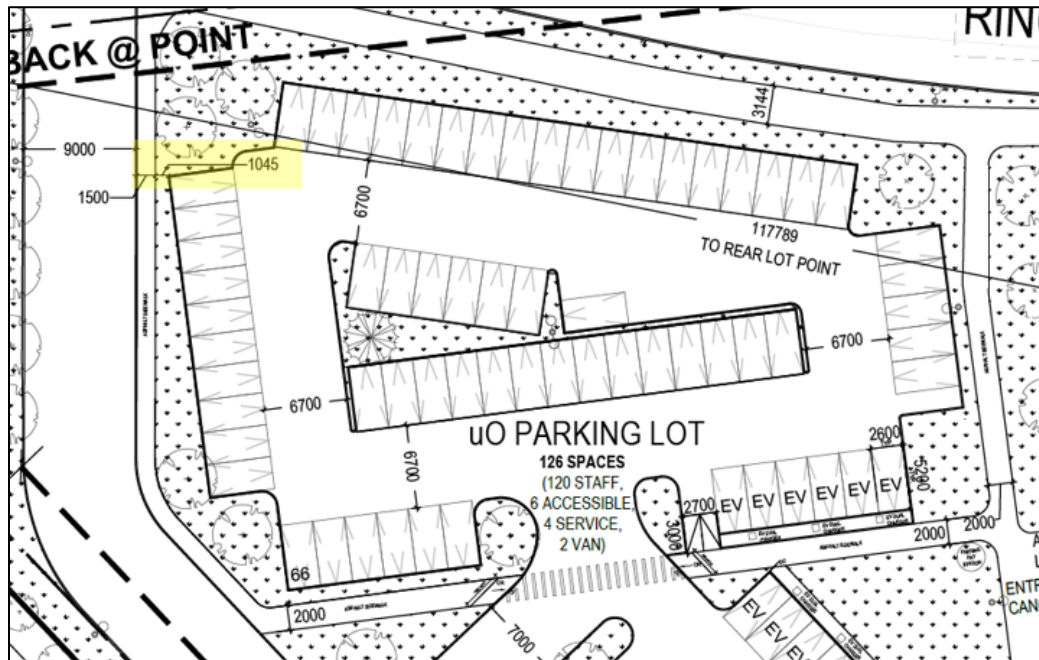

Figure 3-3: Draft Zoning Schedule



The existing parent zone for the site (I2) will be maintained, as it currently permits the post-secondary educational institution use. Permitted uses in the I2 Zone are set out in Section 171 of the Zoning By-law which includes a post secondary educational institution.

The proposed Zoning By-law Amendment would seek to facilitate the proposed development through modification of the performance standards under Urban Exception 402 to add the following site-specific provisions:

- No requirement for a 3 m landscape buffer along the rear lot line; and
- Permit a reduction in the minimum required width of a landscaped buffer of a parking lot abutting a street from 3 m to 1 m.

In addition to the above-noted amendments, the existing provisions under Urban Exception 402 that currently apply to the site will be maintained:

- Minimum front yard setback is 46 metres;
- No parking is permitted within the front yard setback; and
- Parking spaces provided within Area A on Schedule 144 may be used to fulfill parking requirements for development occurring subsequent to February 29, 2004 at 501 Smyth Road.

The draft Zoning By-law Amendment text and Schedule are included as **Appendix B** to this Report.

APPENDIX

A

Site Plan

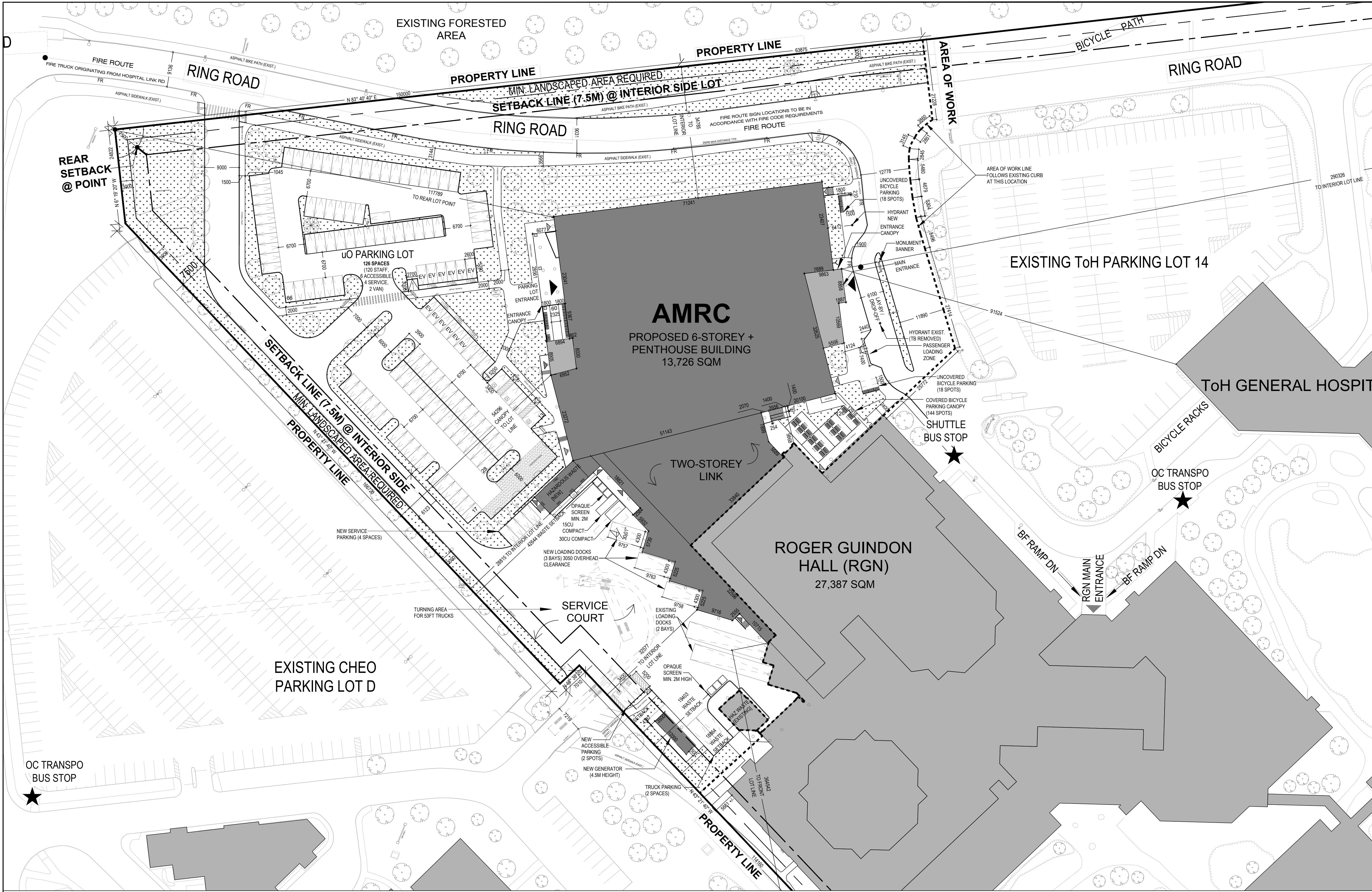

KEY PLAN

REFERENCE SURVEY: 1) 2023-11-25 REF. NO. 105-15 (JIG) GR*
2) 2022-11-22 FILE NO. 623-22**

MUNICIPAL ADDRESS: 451 SMYTH ROAD, OTTAWA, ON K1H 8M5, CANADA
PIN: 04268-0412

ZONE: 12 (H2) F1 (S) S144
AREA B - INNER URBAN
AREA A-B

AREA OF WORK: 24,076.02 M2
COMPLETE SITE AREA: 204,834.211 M2
GFA*** OF PROPOSED AMRC: 13,726.17 M2
GFA*** OF EXISTING BUILDINGS ON SITE: 128,023 M2
GFA*** OF PROPOSED EXIST. BUILDINGS ON SITE: 141,749.17 M2
BUILDING HEIGHT: 40.3M (6 STOREYS + MECH. PENTHOUSE AND ATRIUM ROOF)

No.	Description	Date
4	ISSUED FOR ZBLA AND SPC SUBMISSION	04/18/24
3	ISSUED FOR SPA PHASE 3 RESUBMISSION	04/10/24
2	ISSUED FOR SPA PHASE 3 RESUBMISSION	02/26/24
1	ISSUED FOR REVISED SITE PLAN APPL.	01/22/24



All measurements are to be checked and verified on site by the contractor before proceeding with the work. Do not scale the drawings.

ZONING PROVISION	REQUIRED	PROVIDED
MIN. LOT WIDTH	NO MINIMUM	257.13 M
MIN. LOT AREA	NO MINIMUM	204834.211 M
MIN. FRONT YARD SETBACK	46M	YES - 364.54M
MIN. REAR YARD SETBACK****	7.5M	YES - 117.79M
MIN. INTERIOR YARD SETBACK	7.5M	YES - 34.79M
MAX. HEIGHT	NO MAXIMUM	39.1 M
LANDSCAPED AREA (AREA OF WORK)	15%	22.9% (6502.69 M2)
LANDSCAPED AREA (SITE)	15%	29% (9721.75 M2)

PARKING QUEUING + LOADING	REQUIRED	PROVIDED
EXISTING PARKING SPACES	1617	2079
EXISTING SPACES TO BE ELIMINATED	N/A	361
PROPOSED PARKING SPACES	N/A	120
PROPOSED SERVICE SPACES	N/A	6
PROPOSED ACCESSIBLE SPACES	3	6
PROPOSED TOTAL SPACES	103	126
TOTAL PARKING (EXIST + PROPOSED)	1720	1863
BY USE: AMRC (POST-SEC. FACTOR)	103	126
BY USE: RGN (POST-SEC. FACTOR)	206	191
BY USE: TOTAL POST-SEC. FACTOR	308	317
BY USE: DAYCARE FACTOR	13	11
BY USE: HOSPITAL FACTOR	1399	1535

EXISTING BICYCLE PARKING	REQUIRED	PROVIDED
PROPOSED BICYCLE PARKING (AMRC)	55	477
TOTAL BICYCLE PARKING (PRO + EXIST)	267	622
BY USE: AMRC (POST-SEC. FACTOR)	55	222
BY USE: RGN (POST-SEC. FACTOR)	109	190
BY USE: TOTAL POST-SEC. FACTOR	164	412
BY USE: DAYCARE FACTOR	3	0
BY USE: HOSPITAL FACTOR	100	287

EXISTING LOADING DOCKS 2 2 2

NEW LOADING DOCKS 2 2 3

TOTAL LOADING DOCKS 2 2 5

SITE PLAN GENERAL NOTES:

1. ALL SITE INFORMATION GATHERED FROM SURVEYS 2022-11-22 FILE NO. 623-22 AND 2023-11-25 REF. NO. 101-15 (JIG) GR

2. NO EXISTING TREES TO BE RETAINED - ALL TREES IN PLAN WILL BE PLANTED.

3. SNOW STORAGE WILL OCCUR OFF SITE. AN INTERIM SNOW STORAGE LOCATION HAS BEEN OUTLINED AS PER THE RELEVANT HATCH (SEE LEGEND).

PARKING CALCULATIONS:

VEHICLE:

GFA OF BUILDINGS ON SITE (PER CITY OF OTTAWA DEFINITION):

AMRC = 13,726.17 m2
RGN = 27,387 m2
TOH = 99,988 m2
OASIS = 648 m2

POST-SECONDARY FACTOR (AMRC + RGN) = 0.75 * (13,726.17 + 27,387/100) = 0.75 * (41,113.17) = 308 SPOTS

HOSPITAL FACTOR (TOH) = 1.4 * (99,988/100) = 1,399.83 SPOTS

DAYCARE FACTOR (OASIS) = 1 * (648/250) = 2.59 SPOTS

TOTAL = (308 + 1,399.83 + 2.59) = 1,720.79 SPOTS REQ. = 1,720 SPOTS (ROUNDED)

BICYCLE:

GFA OF BUILDINGS ON SITE (PER CITY OF OTTAWA DEFINITION):

AMRC = 13,726.17 m2
RGN = 27,387 m2
TOH = 99,988 m2
OASIS = 648 m2

POST-SECONDARY FACTOR (AMRC + RGN) = 1 * (13,726.17 + 27,387/250) = 164.45 SPOTS

HOSPITAL FACTOR (TOH) = 1 * (99,988/100) = 99.98 SPOTS

DAYCARE FACTOR (OASIS) = 1 * (648/250) = 2.59 SPOTS

TOTAL = (164.45 + 99.98 + 2.59) = 267.02 SPOTS REQ. = 267 SPOTS TOTAL

PARKIN

Owner: uOttawa

UNIVERSITY OF OTTAWA
451 SMYTH ROAD
OTTAWA, ONTARIO, K1H 8M5
TEL: 613-229-7104

Applicant: **PCL**

PCL CONSTRUCTORS CANADA INC.
49 AVIGNA DRIVE
NEPEAN, ONTARIO, K2E 8A1
TEL: 613-229-7104

Consultants: **wsp**

WSP
6511 QUEENSWAY DRIVE, SUITE 300
OTTAWA, ONTARIO, K2B 9K2
TEL: 613-569-3300

Fairhall Moffatt & Woodland

FAIRHALL MOFFATT & WOODLAND LTD.
600 TERRY FOX DRIVE, SUITE 100
OTTAWA, ONTARIO, K1G 4B9
TEL: 613-591-1495

CLEVELAND JARDINE

CLELAND JARDINE ENGINEERING LTD.
590 TERRY FOX DRIVE
KANATA, ONTARIO, K2L 4B9
TEL: 613-591-1495

MERRICK CANADA

MERRICK
590 TERRY FOX DRIVE
KANATA, ONTARIO, K2L 4B9
TEL: 613-591-1495

Project: **ADVANCED MEDICAL RESEARCH CENTRE**

Address: **451 SMYTH ROAD OTTAWA, ON K1H 8M5**

Drawn By: [] Date: **04/18/2024**

Checked By: [] Scale: **1:500**

Sheet Title: **SITE PLAN - PROPOSED**

Sheet Number: **A100D**

LEGEND

EXISTING ELEMENT	EMERGENCY EXIT	ELECTRIC VEHICLE PARKING SPOT
NEW ELEMENT	PROPERTY LINE	FIRE ACCESS ROUTE SIGN
NEW ELEMENT - CANOPY	SETBACK LINE	CURB RAMP
SNOW STORAGE AREA	LANDSCAPE BUFFER LINE	STANDARD EXT. LIGHT FIXTURE
LANDSCAPED AREA	AREA OF WORK LINE	STANDARD EXT. POST LIGHT
BUILDING ENTRANCE	TREE	ACCESSIBLE PARKING SPOT
SERVICE ENTRANCE	ACCESSIBLE PARKING SPOT	

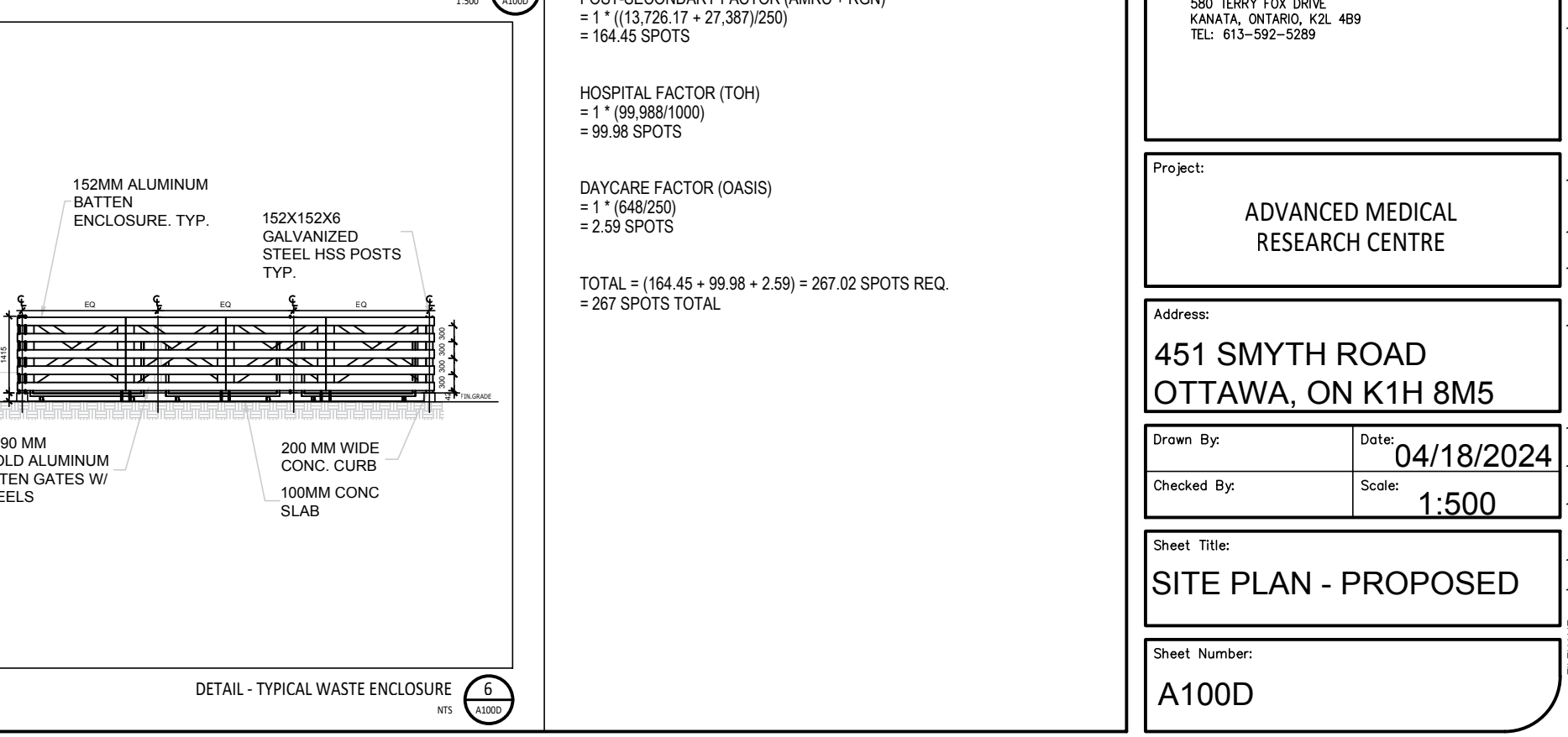
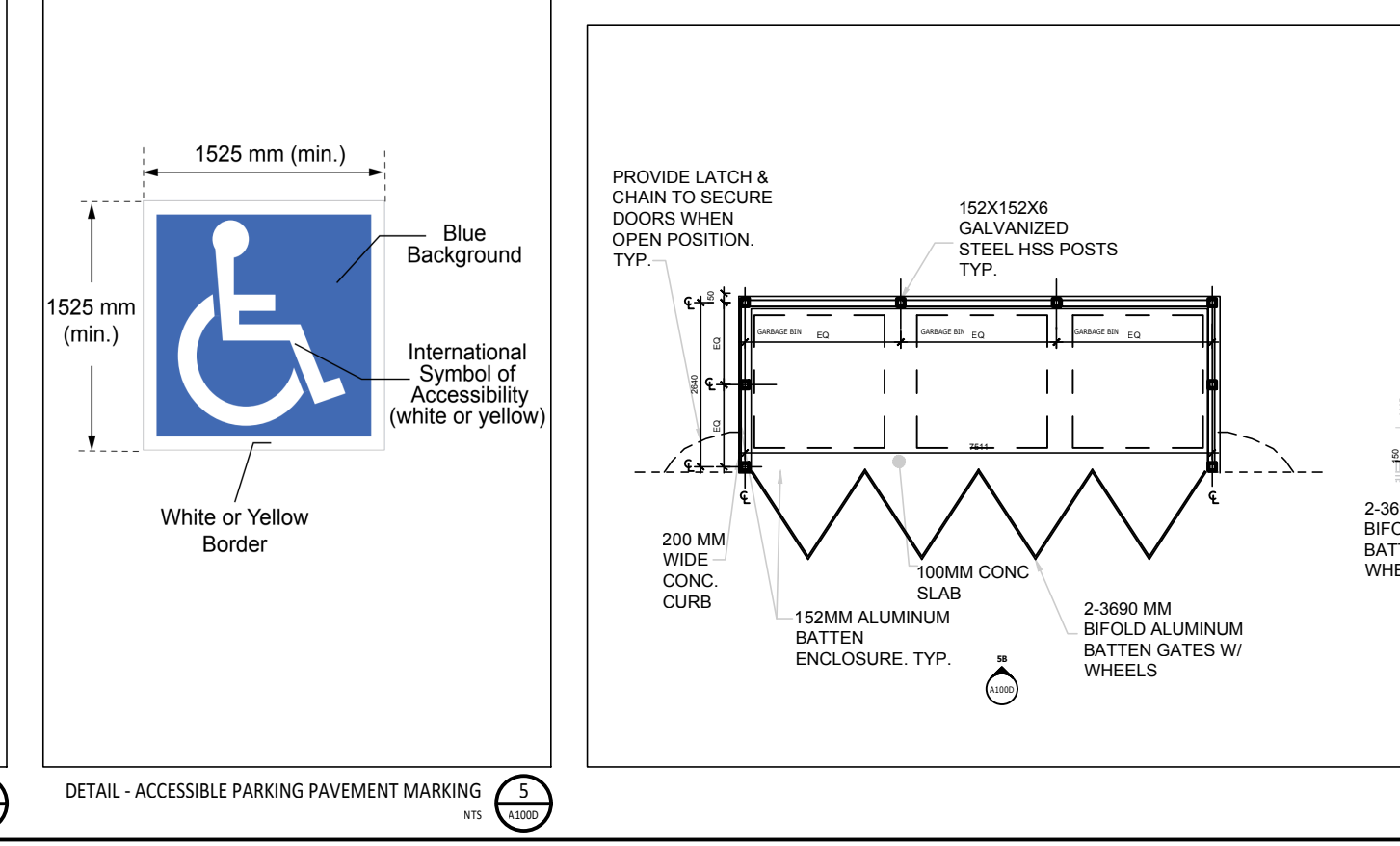
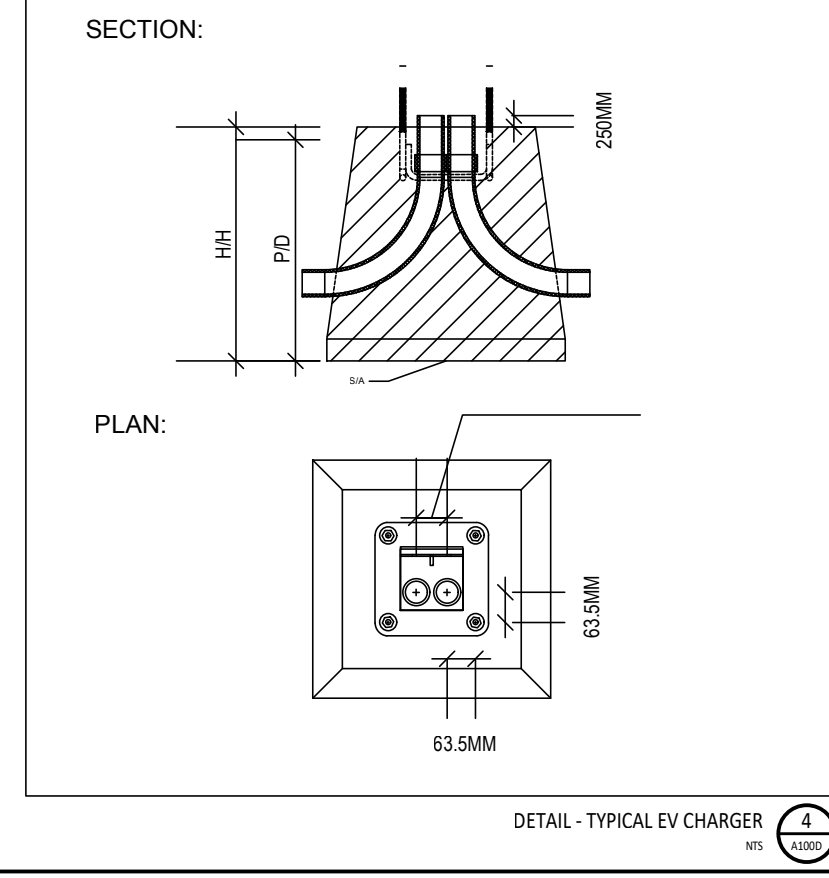
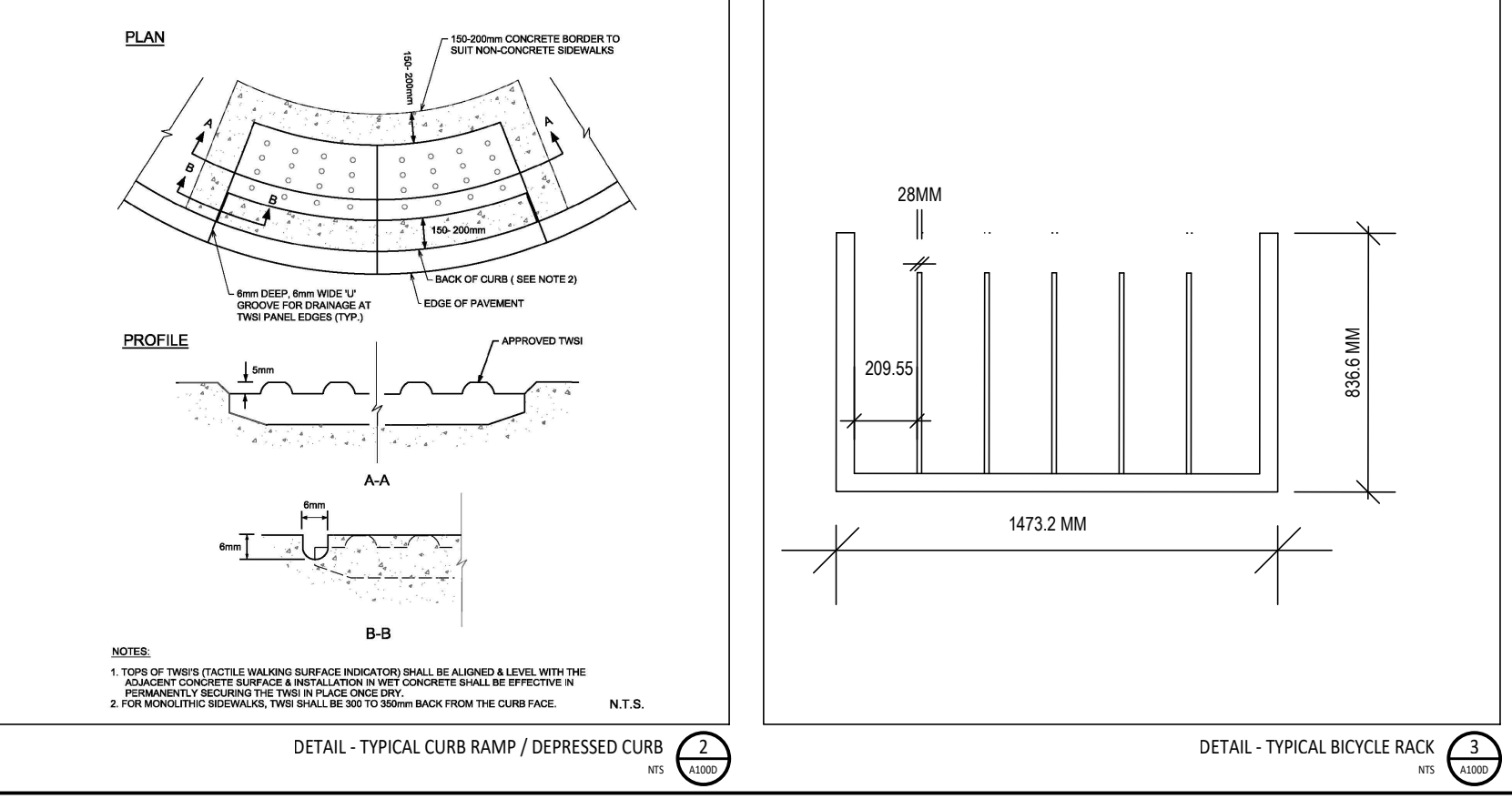

APPENDIX

B

Draft Zoning By-Law Amendment and Schedule

DRAFT BY-LAW NO. 2024-XX

A by-law of the City of Ottawa to amend By-law No. 2008-250 to change the zoning of the lands legally described as Part of Lots 30, 31 and 32, Part of Terrance Road (closed by Judge’s Order INST.GL40441), Registered Plan 405, Part of Lot 15 Junction Gore, Geographic Township of Gloucester, Being Part of the Northerly and Westerly limits of PIN 04258-0412, City of Ottawa. The Council of the City of Ottawa, pursuant to Section 34 of the Planning Act, R.S.O. 1990, enacts as follows:

The Zoning Map of By-law No. 2008-250, entitled “City of Ottawa Zoning By-law” is amended by amending the lands on Attachment 1 to this by-law as follows:

1. To amend Urban Exception 402, with the following provisions shown in **bold**.

I Exception Number	II Applicable Zone	Exception Provisions		
		III Additional Land Uses Permitted	IV Land Uses Prohibited	V Provisions
402 [By-law No. 2024-XX]	I2 [402] F(1.5) S 144 O1[402] S 144	<ul style="list-style-type: none"> • Parking lot and a right-of-way providing access to the parking lot 		<ul style="list-style-type: none"> • No requirement for a 3 m landscape buffer along the rear lot line; • Minimum width of landscaped buffer of a parking lot abutting a street: 1 m; • Minimum front yard setback is 46 metres; • No parking is permitted within the front yard setback; and • Parking spaces provided within Area A on Schedule 144 may be used to fulfill parking requirements for development occurring subsequent to February 29, 2004 at 501 Smyth Road.

ENACTED AND PASSED this _____ day of _____, 2024

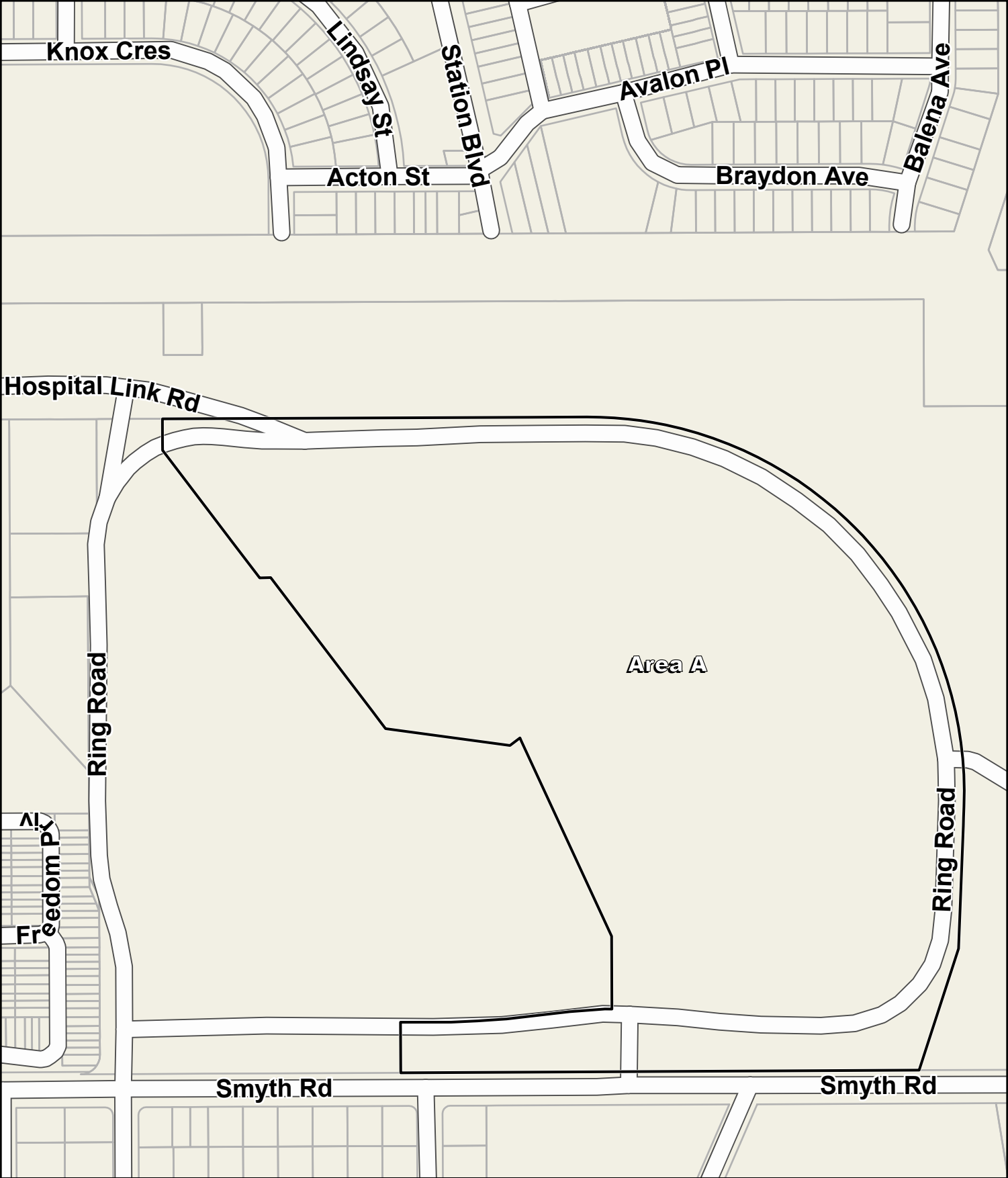

This is "Attachment 1" to
Zoning By-law 2023-XXX

Prepared by WSP
April 2024

- Rezone Area A from I2[402] F(1.5) S144 to I2[XXXX] F(1.5) S144.

Source: GeoOttawa; Open Ottawa

DRAFT

N



1:4000