

ISSUED

No.	Date	Description
0	2023 MAR 22	ISSUED FOR SITE PLAN APPROVAL
1	2023 MAY 12	ISSUED FOR 100% SCHEMATIC DESIGN
2	2023 MAY 18	ISSUED FOR REZONING AND SITE PLAN CONTROL - RESUBMISSION #1
3	2023 JUL 13	ISSUED FOR SITE PLAN CONTROL - RESUBMISSION #2

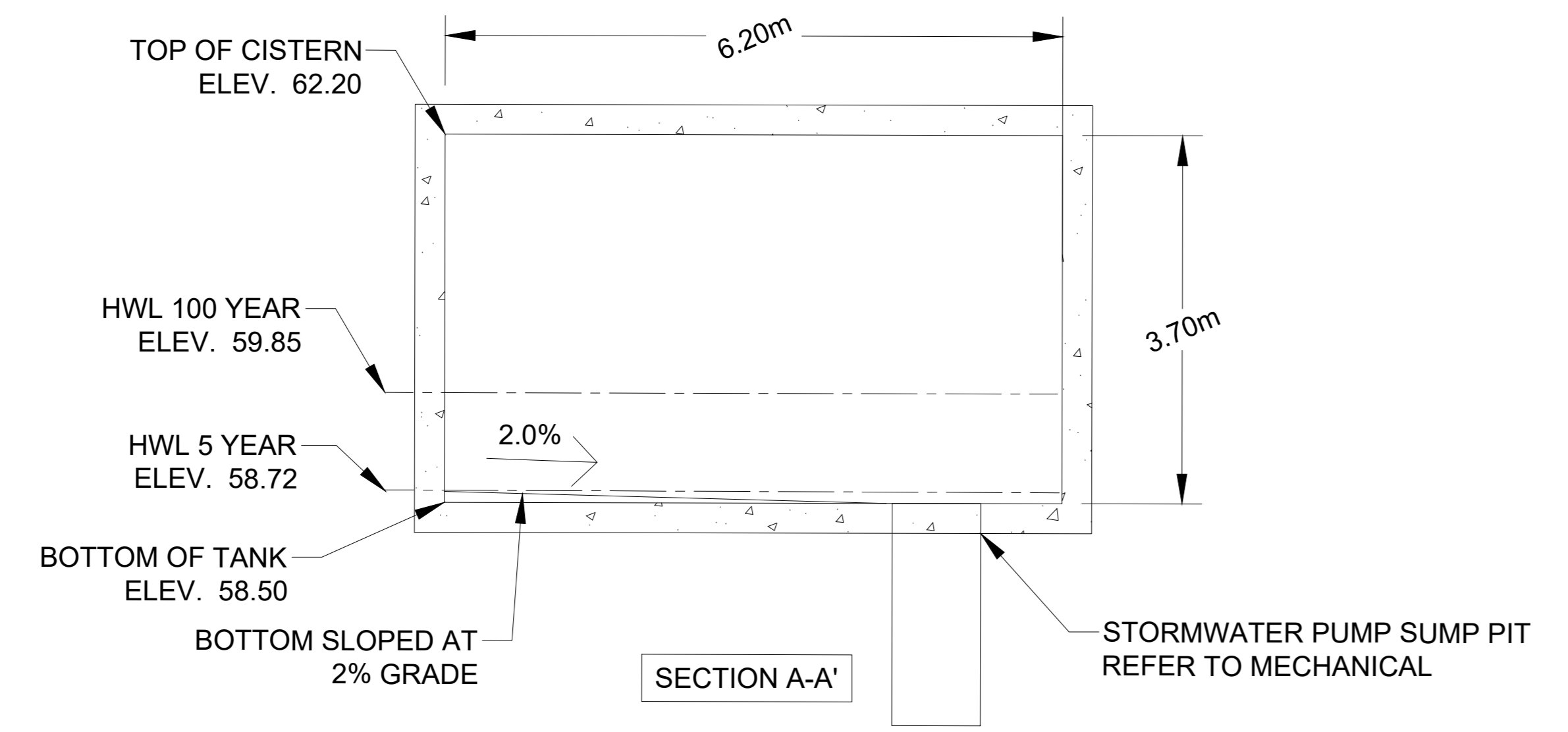
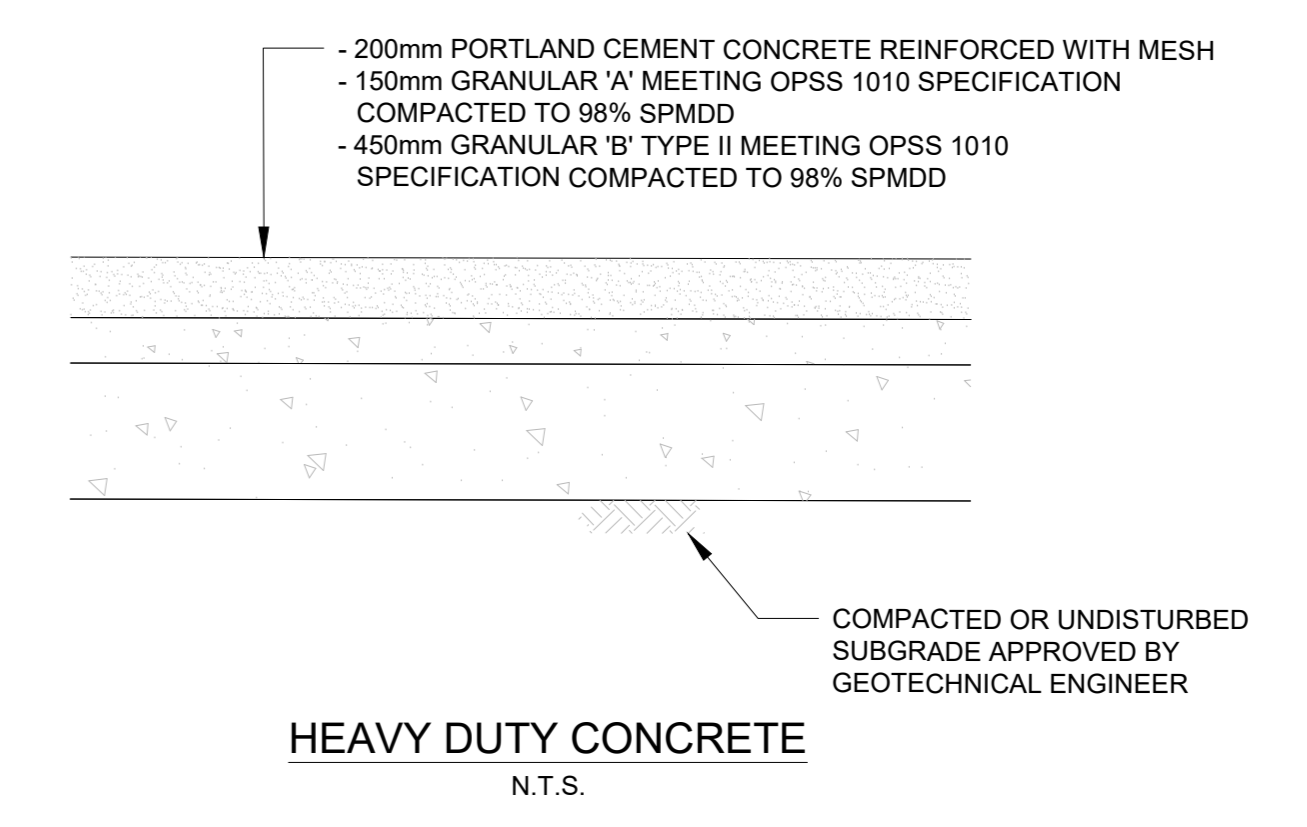
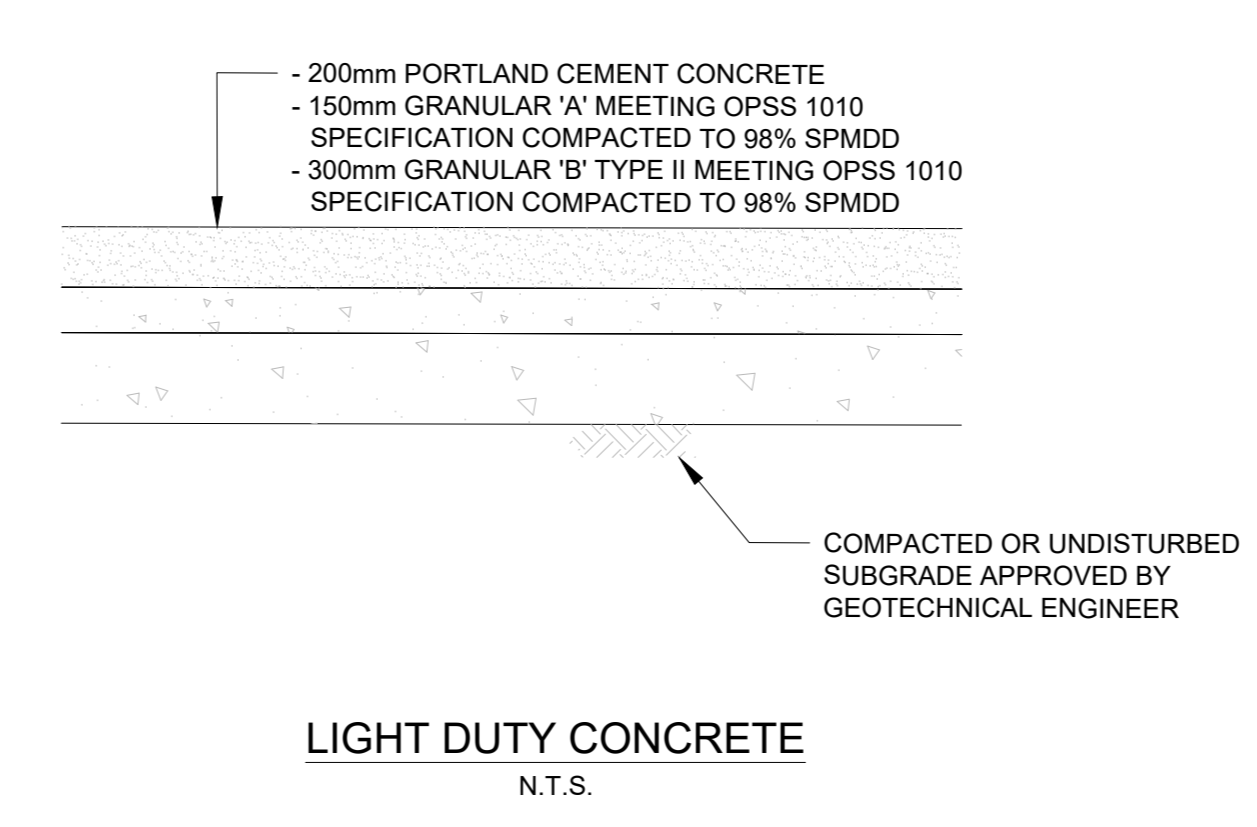
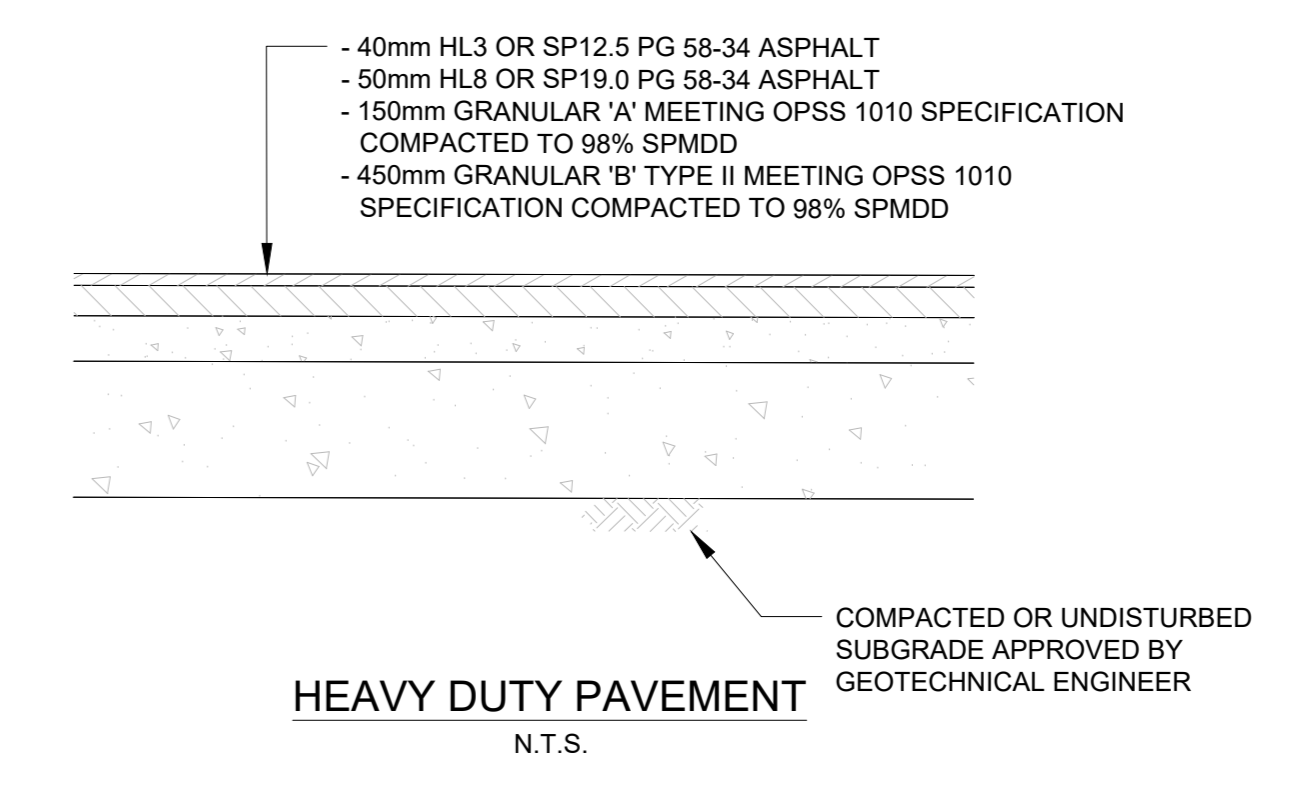
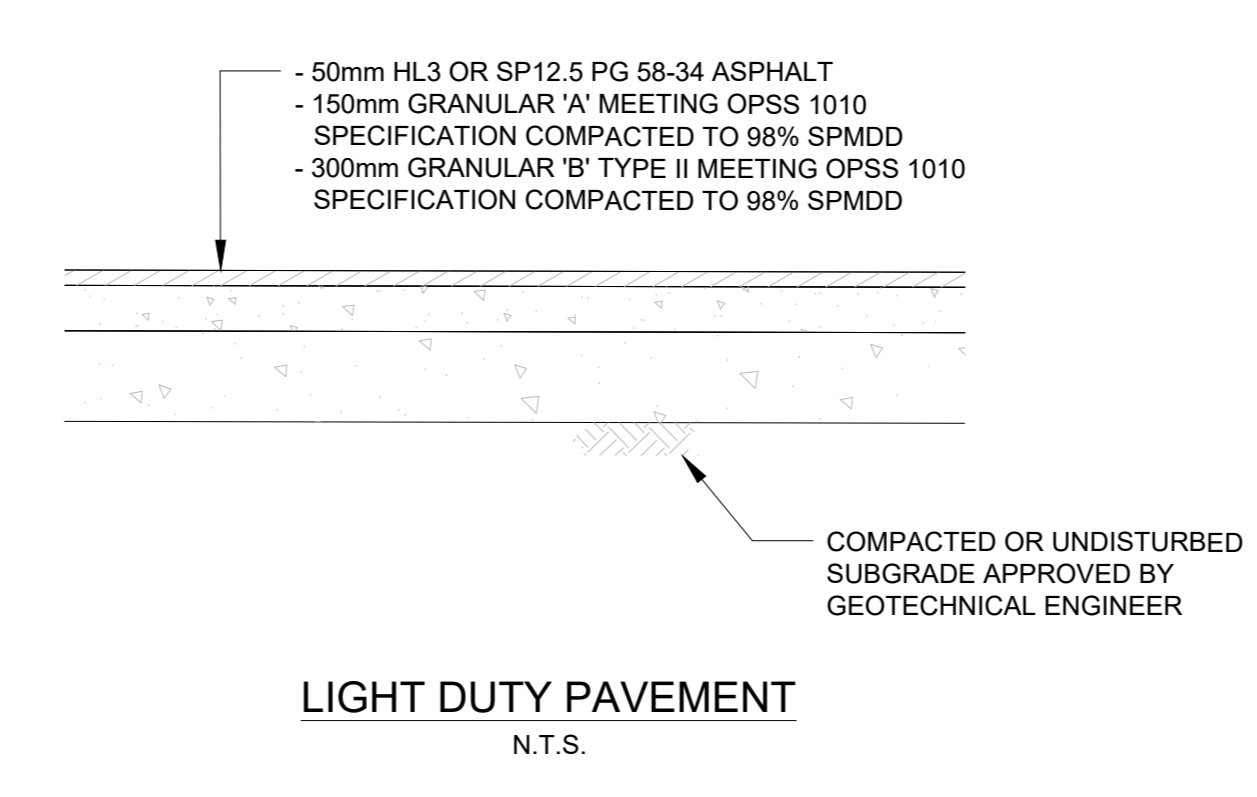
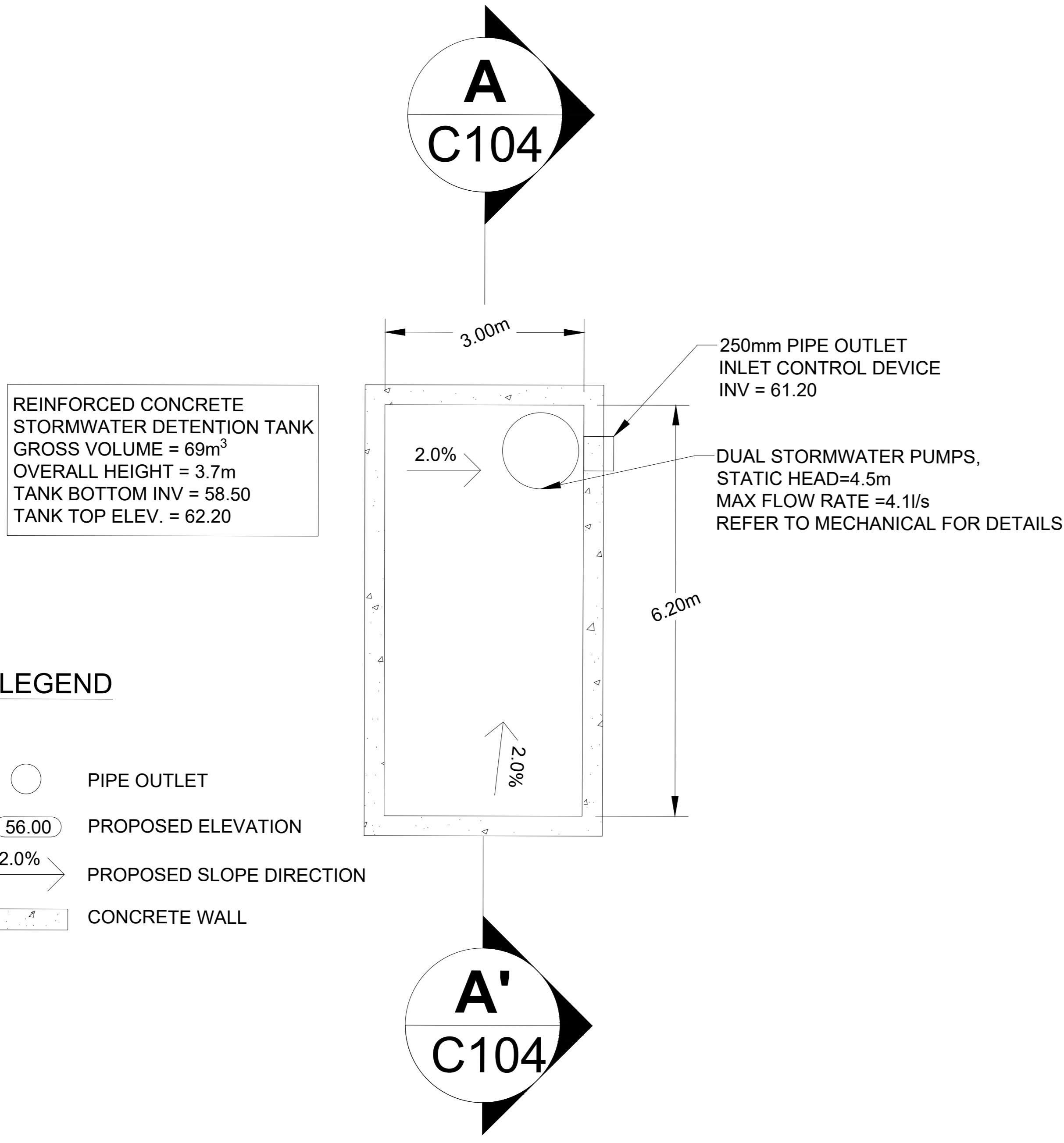

Andrew McCreight

ANDREW MCCREIGHT
MANAGER (A), DEVELOPMENT REVIEW CENTRAL
PLANNING, REAL ESTATE & ECONOMIC DEVELOPMENT
DEPARTMENT, CITY OF OTTAWA

APPROVED
By Andrew McCreight at 4:13 pm, Dec 21, 2023

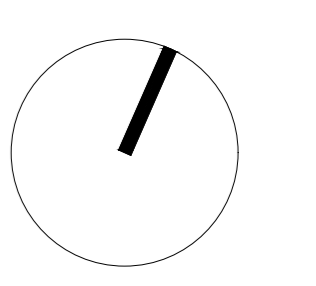

CONTRACTOR MUST CHECK & VERIFY ALL DIMENSIONS ON THE JOB. DO NOT SCALE DRAWINGS.

ALL DRAWINGS, SPECIFICATIONS AND RELATED DOCUMENTS ARE THE COPYRIGHT PROPERTY OF THE ARCHITECT AND MUST BE RETURNED UPON REQUEST. REPRODUCTION OF DRAWINGS, SPECIFICATIONS AND RELATED DOCUMENTS IN PART OR IN WHOLE IS FORBIDDEN WITHOUT THE WRITTEN PERMISSION OF THE ARCHITECT.

THIS DRAWING IS NOT TO BE USED FOR CONSTRUCTION UNLESS SIGNED BY THE ARCHITECT.

OCH FRIEL STREET / CHAPEL
200201 FRIEL STREET
221021