

# **Site Servicing & Stormwater Management Report**

**Commercial Development**

**3850 Cambrian Road**

**Ottawa, Ontario**

# Table of Contents

1.0 INTRODUCTION .....	3
2.0 PURPOSE.....	3
3.0 EXISTING CONDITIONS .....	4
4.0 PROPOSED DEVELOPMENT.....	4
5.0 STORMWATER MANAGEMENT PLAN .....	4
5.1 Pre-Development Conditions .....	5
5.2 Post-Development Conditions.....	5
5.3 PCSWMM Modeling.....	6
5.3.1 Input Parameters .....	6
5.3.2 PCSWMM Model Results.....	7
6.0 STORM SEWERS AND STORMWATER MANAGEMENT SYSTEM .....	8
6.1 Storm Sewers.....	8
6.2 Emergency Major Overland Flow Route .....	8
6.3 Stormwater Management System.....	9
7.0 SANITARY SEWER .....	9
8.0 WATER SERVICING.....	9
9.0 EROSION AND SEDIMENT CONTROL DURING CONSTRUCTION .....	10
10.0 CONCLUSIONS .....	11

## List of Tables

Table 1 – PCSWMM Subcatchment Hydrologic Parameters.....	6
Table 2 – 100-year Storm Event Peak Flows .....	7
Table 3 – 100-year Storm Event Storage.....	7
Table 4 – Maximum HGL and Ponding Depth at Junctions.....	8
Table 5 - ICD Schedule .....	9
Table 6 - Building Water Demands and Fire Flow .....	10

## List of Figures

Figure 1 – Site Context.....	3
------------------------------	---

### **List of Appendices**

- Appendix A: Stormwater Management Calculations
- Appendix B: Storm and Sanitary Sewer Computation Forms
- Appendix C: Sanitary Load and Fire Flow
- Appendix D: WaterCad Model Results
- Appendix E: Stormwater Storage Chambers Specifications
- Appendix F: City Correspondence
- Appendix G: Zurn Control-Flo Roof Drains Specifications
- Appendix H: PCSWMM Model Results

### **Drawings**

- Drawing C101 | Erosion/Sediment Control & Existing Conditions Plan
- Drawing C102 | Site Servicing Plan
- Drawing C103 | Grading Plan
- Drawing C104 | Detail Page 1
- Drawing C105 | Detail Page 2
- Drawing C106 | Post Development Drainage Plan

## 1.0 INTRODUCTION

Parsons Inc. was retained by Choice Properties Limited Partnership to provide engineering services for a new commercial development located at 3850 Cambrian Road in Ottawa, Ontario.

The site encompasses a total area of approximately 1.36 ha and is bordered by residential developments to the north and west, Cambrian Road to the south and the future re-aligned Greenbank Road to the east as shown on the following figure.

The proposed development includes the addition of a retail store and three other commercial rental units on the same lot. Servicing of the buildings will be provided by the new on-site storm sewers, sanitary services, and new water services from Cambrian Road. New fire hydrants will be added on-site to provide exterior fire protection.

Figure 1 – Site Context



## 2.0 PURPOSE

This report summarizes the proposed site servicing, grading and drainage design, documents the proposed method of attenuating stormwater runoff from the subject site, and deals with erosion and sediment control measures to be undertaken during construction.

Stormwater management items addressed include the following:

- establishing the allowable post-development release rate from the site;
- calculating the post-development runoff from the site;
- determining the required on-site stormwater storage volume and storage areas.

### 3.0 EXISTING CONDITIONS

The subject site is currently vacant. The proposed commercial development is part of the Half Moon Bay West Subdivision. As mentioned earlier, on the east site of the proposed development, the future re-aligned Greenbank Road will be constructed as part of the Greenbank Realignment and Southwest Transitway Extension (GRSWTE) project. Currently, there is no access to the subject site from Greenbank Road. Cambrian Road is currently the only access to the subject site. Cambrian Road will be widened as part of the new Greenbank Road project. Addition of sidewalks and bike lanes is also proposed as part of this future project. A new 1500mm storm sewer, 500mm sanitary sewer and 400mm watermain have been installed in 2019 along Cambrian Road and will be used to provide services to the proposed commercial development. There is also a 400mm watermain and 2550mm storm sewer installed within the future Greenbank Road right-of-way. A 750mm storm service, 200mm sanitary service and a 200mm water service have also been installed in 2019 up to the property line to service this future development from Cambrian Road. Refer to **Drawing C101** for more details.

According to the geotechnical investigation report for this development, by GeoTerre Limited dated February 17, 2023, soil condition on this site consists of up to 3m of organic material fill with an underlayer of between 15m and 20m of weak silty clay "Leda Clay". Also, the groundwater table is estimated at an elevation of 92.0m. Existing site surface elevation varies between 92.19m and 95.11m.

### 4.0 PROPOSED DEVELOPMENT

As shown on the Architectural Site Plan, the proposed development will consist of a new 1579 m<sup>2</sup> retail store (Building A) and three commercial rental units of 595 m<sup>2</sup> (Building B), 799 m<sup>2</sup> (Building C) and 418 m<sup>2</sup> (Building D). Building A and Building B are considered as two different units, however they do share the same foundation and finished floor elevation. The finished floor elevation of Building A and B is set at 93.92m, Building C at 94.0m and Building D at 94.20m. Each building is considerably higher than the estimated groundwater table elevation. The proposal will also include parking spaces, concrete sidewalks, concrete curbs, a new entrance from Cambrian Road and two entrances from the future Greenbank Road.

The site grading will match the existing conditions along the residential properties on the north and west side of the subject site. Grading along Cambrian Road and future Greenbank Road will match the future back of sidewalk grades provided by the GRSWTE team and from these future grades, it will tie-in to existing conditions.

### 5.0 STORMWATER MANAGEMENT PLAN

**Drawing C106**, appended to this report, depicts the boundaries of the post-development drainage areas, and should be read in conjunction with this report.

The design approach for the stormwater management is to ensure that the post-development peak flows do not exceed the allowable release rate to mitigate the risk of flooding and against erosion. The City of Ottawa indicated that the allowable release rate for this site was determined in the *Design Brief for the Half Moon Bay West Phase 1, prepared by DSEL, dated September 5, 2018*. Correspondence with the City can be found in **Appendix F**. The storm sewers installed as part of this new subdivision project are sized to allow a flow of **316.1 L/s** for the proposed commercial development. Parameters used to calculate the allowable release rate are from the DSEL report.

- Runoff Coefficient (C) = 0.80
- Drainage Area (A) = 1.36 ha
- Time of Concentration (T<sub>c</sub>) = 10min

The Rational Method formula has been used to calculate stormwater runoff and rainfall data is based on the IDF curve equations from the *Ottawa Sewer Design Guidelines, Second Edition, October 2012*.

$$Q = 2.78 CIA, \text{ where:}$$

Q = Flow rate (L/s)  
C = Runoff coefficient  
I = Rainfall intensity (mm/hr)

A = Area (ha)

Rainfall intensity:  $I_5 = 998.071 / (T_c + 6.053)^{0.814}$

Using the Rational Method formula and the above parameters, the allowable post-development release rate for this site is **316.1 L/s**.

## 5.1 Pre-Development Conditions

As mentioned earlier, the subject site is currently vacant. Based on the topographical survey received, the site grading is higher on the edge of the future Greenbank Road and the lowest point is located on the south-west border of the site near Cambrian Road. A drainage ditch used to flow through this site, however this ditch was abandoned as part of the construction of new infrastructure along Cambrian Rd and future Greenbank Rd. Existing roadside ditch along Cambrian Rd is currently collecting runoff from the road and is intercepted by a temporary ditch inlet connected to the existing 1500mm storm sewer. Services for this property were installed in 2019. A Storm catch basin maintenance hole (CBMH) with a 750mm pipe was installed at the property line along Cambrian Rd and collects stormwater runoff from this site.

## 5.2 Post-Development Conditions

As mentioned earlier, proposed building A and B are considered as two different unit, thus separate services for each unit will be provided. All roof areas will be controlled with roof drain systems. Each building will have a separate roof drain outlet.

The following is a description of each drainage areas through the site, refer to **Appendix A** and **Drawing C106** attached to this report.

- Areas WS-01 to WS-04 consist of the controlled roof areas;
- Area WS-05 is the entrance from Cambrian Rd as well as the patio of building C;
- Areas WS-06 to WS-10 consist of the main parking lot area;
- Areas WS-11 and WS-12 are the grassed area and garbage disposal area between building C and D;
- Area WS-13 is the proposed swale on the corner the Cambrian and future Greenbank intersection, located behind the future Greenbank sidewalk;
- Area WS-14 consist of the proposed swale/grassed area between the building A and the future Greenbank sidewalk;
- Areas WS-15 to WS-17 consist of the area behind building A and B including the loading dock and proposed entrance from future Greenbank Rd.

Since this project will be constructed before the new re-aligned Greenbank Rd, the grading of the site must match existing surface elevations at the property line while also considering the future Greenbank Rd project proposed sidewalk and road profile. Due to the important variation in grades between existing conditions and future conditions along Cambrian Rd and Greenbank Rd, grading along the property lines of the site will match existing conditions and the future Greenbank/Cambrian sidewalk with a maximum slope of 3H:1V. This means that a small portion of this site will not be retained and will drain uncontrolled outside of private property. The uncontrolled area of this site is estimated at 0.03 ha and generates a flow of 4.1 L/s and 8.8 L/s for the 5-year and 100-year storm event respectively. Considering the uncontrolled flow, the adjusted allowable 100-year storm event flow is **307.3 L/s**. Refer to **Appendix A** for more details.

All other areas on-site will be captured through a new on-site storm sewer system.

To control the site discharge to the maximum **307.3 L/s** for the 100-year storm event, underground storage, rooftop storage and inlet-control device (ICD) will be used. The stormwater management system was designed using the modeling software PCSWMM. The dynamic model created is described below.

## 5.3 PCSWMM Modeling

### 5.3.1 Input Parameters

A dynamic model was created to evaluate the proposed stormwater management system and storm sewer infrastructure using the software PCSWMM. Hydrologic parameters used for the subcatchments in the model were taken from the Ottawa Sewer Design Guidelines and are presented below:

**Table 1 – PCSWMM Subcatchment Hydrologic Parameters**

Parameter	Value
Design Storm	3-hour Chicago Storm (5-yr, 100-yr, 100-yr + 20%)
Infiltration Method	Horton
Max. Infiltration Rate (mm/hr)	76.2
Min. Infiltration Rate (mm/hr)	13.2
Decay Constant (1/hr)	4.14
Drying Time (days)	7
Impervious Area Manning's Coefficient (N)	0.016
Pervious Area Manning's Coefficient (N)	0.15
Depth of Depression Storage Imp. Area (mm)	1.57
Depth of Depression Storage Perv. Area (mm)	4.67
Zero Impervious Area (%)	25

Other subcatchments parameters such as the area, width, slope and percent of impervious area are taken from **Drawings C103** and **C106**.

Junctions, conduits and outfalls parameters are taken from **Drawing C102**.

Storage and outlet nodes were created to represent the proposed underground storm chambers, the controlled roof drains and surface ponding in the loading dock area. Parameters and storage curve used to model the underground storm chambers are taken from the StormTech Chamber design created using the online Design Tool by ADS, please refer to **Appendix E** for more details. The storage curve created to represent the loading dock ponding was created using the loading dock longitudinal profile and area.

Storage curves for controlled roof drains were created assuming a maximum of 0.15m of ponding for the entire building roof area, while rating curves created for the outlet nodes are based on the Zurn Control-Flo Roof Drains Specifications. Roof drain specifications are shown in **Appendix G**. Based on these specifications, the maximum flow per notch for one roof drain is 2.28 L/s for a ponding height of 0.15m. The number of roof drains per building was estimated by using an area of 232.5m<sup>2</sup> per drain, which represent a conservative approach according to the Zurn specifications. The rating curve for each building roof drain system is the following:

$$f(x) = 2.28x$$

Where,

$f(x)$  = height of ponding of the roof (max. 0.15m)

2.28 = max. flow in L/s per notch per drain

x = number of roof drains on the building

For the ICD, an orifice node was created. The discharge coefficient ( $C_d = 0.61$ ) used for the orifice was taken from the Ottawa Sewer Design Guidelines. The size of the orifice is based on the allowable discharge for the site.

A summary of the input parameters for the PCSWMM model are presented with the model results in **Appendix H**.

### 5.3.2 PCSWMM Model Results

The dynamic model was created to ensure that enough storage is provided onsite to attenuate the 100-year post-development flow to the target discharge rate of **307.3 L/s** and that the 100-year + 20 % (climate change event) does not cause any flooding to buildings or neighbouring properties. The 5-year storm event was also evaluated to ensure that the proposed storm sewers are flowing under free-flow conditions.

Based on the 3h Chicago 100-year storm event, the maximum total peak flow from the site is estimated at **619.4 L/s**. To attenuate the maximum peak flow to the allowable target rate, an orifice ICD with a diameter of 320 mm was added on the outlet pipe of MHST-8. The resulting peak flow of the outfall node was reduced at **306.0 L/s** which is under the target flow rate. The following table summarizes the results for the 100-year storm event peak flows.

Table 2 – 100-year Storm Event Peak Flows

Outfall Node	Uncontrolled Peak Flow (L/s)	Allowable Peak Flow (L/s)	Controlled Peak Flow (L/s)	Peak Flow Attenuation	Meets Allowable Discharge
EX-MHST	619.4	307.3	306.0	50.5 %	Yes

To attenuate the 100-year peak flow to the target rate, on-site stormwater will be stored on rooftops and in underground storm chambers. The following table provides a summary of the different storage facilities.

Table 3 – 100-year Storm Event Storage

Storage Node	Available Storage (m <sup>3</sup> )	Max. Storage Used (m <sup>3</sup> )	Max. Storage Used (%)	Max. HGL (m)	Ponding Depth (m)
Chambers	70.0	54	78	92.50	0.50
Building A Roof	119.2	62	52	-	0.11
Building B Roof	45.1	23	51	-	0.11
Building C Roof	58.8	30	51	-	0.11
Building D Roof	31.4	16	51	-	0.11
Total	325	186	57.2	-	-

As shown in **Table 3**, the ponding depth on all building roofs are under the maximum ponding depth of 0.15 m. Also, only 78% of the available storage in the proposed underground storm chambers is used. However, it is worth noting that some surface ponding is occurring in the loading dock area. The maximum ponding in the loading dock area is only 0.17 m over the trench drain elevation and the ponding area is shown on **Drawing C103**. Except for the loading dock area, no other surface ponding is observed during the 100-year storm event.

As mentioned above, the 100-year storm event + 20% (climate change event) was evaluated to ensure that it would not cause any flooding to proposed buildings or neighbouring properties. The following table summarizes the maximum hydraulic grade line (HGL) and ponding height over each junction for the 100-year and climate change storm event.



Table 4 – Maximum HGL and Ponding Depth at Junctions

Junction ID	Rim Elevation (m)	3h Chicago – 100-Year		3h Chicago – 100-Year + 20%	
		Max. HGL (m)	Ponding Depth (m)	Max. HGL (m)	Ponding Depth (m)
CB-19	93.00	93.00	-	93.07	0.07
TD-Loading Dock	92.62	92.79	0.17	92.88	0.26
CBMH-16	93.00	92.84	-	93.00	-
MHST-18	93.42	92.78	-	92.97	-
MHST-3	93.50	92.63	-	92.86	-
RY-CB-15	93.14	92.50	-	92.82	-
MHST-14	93.92	92.50	-	92.82	-
CBMH-13	93.55	92.50	-	92.81	-
MHST-17	93.60	92.51	-	92.83	-
RY-CB-11	93.71	92.42	-	92.68	-
MHST-10	94.19	92.43	-	92.68	-
MHST-9	93.74	92.43	-	92.68	-
SC-MH-20	93.46	92.46	-	92.66	-
MHST-8	93.74	92.43	-	92.66	-
MHST-6	93.91	90.62	-	90.63	-
EX CBMH	93.67	90.26	-	90.27	-

As shown in **Table 4**, only CB-19 and the trench drain have surface ponding for the climate change storm event. The extent of the maximum ponding area is shown on **Drawing C103**. No flooding is observed as ponding depth are below 0.3 m and significantly below buildings finished floor elevation.

Detailed results from the PCSWMM model are provided in **Appendix H**.

## 6.0 STORM SEWERS AND STORMWATER MANAGEMENT SYSTEM

### 6.1 Storm Sewers

Calculations showing the storm sewer capacities are appended to this report under **Appendix B** “Storm Sewer Computation Forms”. The storm sewer design spreadsheet is based on the Rational Method and Manning formula and was used to calculate the design flow and required pipe sizes. Capacity required for proposed storm sewers is based on the 5-year rainfall intensity obtained from the Ottawa Sewer Design Guidelines, where  $T_c$  is the time of concentration:

- $I_5$  (mm/hr) =  $998.071 / (T_c + 6.053)^{0.814}$

**Drawing C106** shows the proposed drainage areas. Details including pipe lengths, sizes, materials, inverts elevations and structure types are shown on **Drawing C102**.

### 6.2 Emergency Major Overland Flow Route

As mentioned above, no significant ponding is expected for the 100-year and climate change storm event. However, in case of blockage, the emergency overland flow routes were added to **Drawing C106**. The emergency overland flow route for majority of the site consists of the rear-yard ditch system and existing pathway located along the residential properties to the west of the subject site. This major overland flow route is identified in the DSEL report.

### 6.3 Stormwater Management System

As mentioned above, the stormwater management system includes an ICD on the outlet pipe of MHST-8 that will control the site discharge to a maximum of **306.0 L/s**. The total allowable discharge from the site is **316.1 L/s** including uncontrolled areas. Uncontrolled flow is estimated at **8.8 L/s** for the 100-year storm event. Therefore, the site total discharge is estimated at **314.8 L/s**.

The **Table 5** lists all the requirements for the manufacturer to design the appropriate ICD.

Table 5 - ICD Schedule

ICD ID	Location	Outlet Diameter (mm)	100y (L/s)	Head 100y (m)	Equivalent Diameter (mm)	Model
1	MHST-8	600	287.6	2.08	320	FRAME & PLATE

Below grade storage will be provided by storm structures, pipes, and mainly underground storm chambers. All roof areas will also be controlled to provide additional storage. The design will utilize **54 m<sup>3</sup>** of storage in the underground storage chambers for the 100-year storm event, however 70.0 m<sup>3</sup> are available within the underground chamber system. The proposed system consists of the StormTech SC-310 or equivalent, see **Appendix E** for specifications. The bottom of the proposed chambers is set above the estimated groundwater table elevation (92.0m). Perforated subdrains will be placed on the perimeter of the storm chambers, directly above the elevation 92.0m to collect infiltration from the chambers and redirect it to the storm outlet.

The site stormwater runoff ultimately discharges to the Jock River. There is no on-site stormwater quality treatment required as the runoff from the site is conveyed to the Clarke Pond before discharging in the Jock River. The Clarke Pond was designed and constructed to provide a minimum of 80% TSS removal for all stormwater generated from the Half Moon Bay West Subdivision.

### 7.0 SANITARY SEWER

The new commercial units within the proposed development will be served with a new on-site sanitary system. Each building will have its own sanitary service. The on-site sanitary system will be connected to the existing sanitary maintenance hole previously installed for this future development located at the property line along Cambrian Road. The peak sanitary flow for the proposed commercial development is calculated to be **0.61 L/s**, including infiltration. The sanitary load calculations can be found in **Appendix C**. The additional flow from the commercial development to the municipal sanitary sewer was accounted for in the Half Moon Bay Subdivision design. Thus, the capacity of the downstream sanitary sewer is considered adequate. The Sanitary Sewer Computation Sheet is included in **Appendix B**. Details concerning the existing and proposed pipe lengths and locations are shown on the site servicing plan.

### 8.0 WATER SERVICING

Water servicing and fire protection for the proposed commercial development will be provided by a new on-site 200mm watermain connected to the existing 400mm watermain on Cambrian Road. Two new fire hydrants will be installed on-site to provide exterior fire protection, as a fire hydrant located within 75m of a building can provide a maximum fire flow of 95 L/s and the maximum fire flow required on-site is **100 L/s**. Details regarding the new and existing watermain service connection pipe size and location are shown on **Drawing C102**. Buildings A and B are expected to have interior sprinkler systems, thus the water services for these building will be a 200mm diameter. Buildings C and D are not expected to have sprinkler systems, only 50mm services will be provided.

The water demands for the proposed development are listed in **Table 6**. The fire flow was calculated using the Fire Underwriters Survey (FUS, 2020) method. Calculation details can be found in **Appendix C**.

**Table 6 - Building Water Demands and Fire Flow**

	<b>Average Daily Demand (L/s)</b>	<b>Max Daily Demand (L/s)</b>	<b>Peak Hourly Demand (L/s)</b>	<b>Fire Flow Demand (L/s)</b>	<b>Max Daily + Fire Flow Demand (L/s)</b>
Building A	0.05	0.08	0.14	100	100.08
Building B	0.02	0.03	0.05	50	50.03
Building C	0.03	0.04	0.07	100	100.04
Building D	0.01	0.02	0.04	83	83.02

Boundary conditions were obtained from the City on March 27, 2023, and are presented in **Appendix F**. Based on the information received, a water model was created using WaterCad to confirm that the proposed watermain and fire hydrants were able to provide domestic and fire flow demands while maintaining adequate pressure in the system. The water model shows that the proposed system has the required capacity to provide domestic and fire protection demands. However, for the average day demand, the pressure in the system is over 550 kPa (80 psi) meaning that every building water connection will require water pressure reducing valve installed directly downstream of the water meter inside the building. Water model results are shown in **Appendix D**.

## 9.0 EROSION AND SEDIMENT CONTROL DURING CONSTRUCTION

To mitigate the impacts due to erosion and sedimentation during construction, erosion and sediment control measures shall be installed and maintained throughout the duration of construction.

Measures shall only be removed once the construction activities are complete, and the site has stabilized.

The measures will include but are not limited to:

- Siltsack® shall be installed between the frame and cover of existing and new catchbasins and maintenance holes, to minimize sediments entering the storm drainage system.
- All grassed areas must be completed prior to the removal of the Siltsack® in catch basins and maintenance holes.
- Light Duty Silt Fence Barriers placed around the perimeter of the site where necessary, installed and maintained according to OPSS 577 and OPSD 219.110.
- Construction mud mat at site entrance along Cambrian Rd to minimize the amount of mud carried out of the site.

Refer to **Drawing C101** notes for more details.

## 10.0 CONCLUSIONS

A dynamic model using the software PCSWMM was created to design the proposed stormwater management system and to ensure that the site peak flow meets the established allowable discharge of **316.1 L/s** for the 100-year storm event. According to the model, the 100-year peak flow will be controlled to a maximum discharge of **314.8 L/s** including uncontrolled areas, which meets the target discharge. Stormwater storage is provided to attenuate the 100-year storm in underground chambers and on building rooftops prior to discharging to the municipal storm sewer system. On-site stormwater quality treatment is not required as this site is part of the area serviced by the Clarke Pond.

The water servicing of the building addition will be provided by a new on-site 200mm watermain with two new fire hydrants. The maximum fire flow of the four proposed building was estimated at **100 L/s**. A water model was used to confirm that adequate pressure in the system could be maintained during a fire flow demand. However, pressure in the City system during average day demands is too high and will trigger the addition of pressure reducing valves inside the buildings.

The sanitary servicing of the site will be provided by an on-site sanitary sewer connected to the existing 500mm sanitary along Cambrian Rd. The peak sanitary flow for the proposed development, including infiltration, is calculated to be **0.61 L/s**.

Grading and drainage measures will ensure proper drainage of the site, while erosion and sediment control measures will minimize downstream impacts due to construction activities.

We look forward to receiving approval of this report and the appended plans from the City of Ottawa in order to proceed with construction of the site.

Prepared by:

Reviewed by:



Benoit Villeneuve, P.Eng., ing.



Mathew Theiner, P.Eng., ing.

**Appendix A:  
Stormwater Management Calculations**

**TABLE I - ALLOWABLE RUNOFF CALCULATIONS BASED ON EXISTING CONDITIONS**

Area Description	Area (ha)	Time of Conc, Tc (min)	Minor Storm			
			Storm = 5 yr	I <sub>5</sub> (mm/hr)	C <sub>AVG</sub>	Q <sub>ALLOW</sub> (L/s)
EWS-01	1.36	10	Storm = 5 yr	104.19	0.80	<b>316.1</b>
<b>TOTAL</b>	<b>1.36</b>					<b>316.1</b>

Allowable Capture Rate is based the Design Brief for the Half Moon Bay West Phase 1, prepared by DSEL, Project #16-888, dated September 5, 2018

5-year Storm	C <sub>ASPH/ROOF/CONC</sub> =	<u>0.90</u>	C <sub>GRASS</sub> =	<u>0.20</u>
100-year Storm	C <sub>ASPH/ROOF/CONC</sub> =	<u>1.00</u>	C <sub>GRASS</sub> =	<u>0.25</u>

**TABLE II - POST-DEVELOPMENT AVERAGE RUNOFF COEFFICIENTS**

Watershed Area No.	Impervious Areas (m <sup>2</sup> )	A * C <sub>ASPH</sub>	Pervious Areas (m <sup>2</sup> )	A * C <sub>GRASS</sub>	Sum AC	Total Area (m <sup>2</sup> )	C <sub>AVG</sub> (5yr)	C <sub>AVG</sub> (100yr)	% Impervious
WS-01*	1576.00	1418	0.00	0	1418	1576	0.90	1.00	100%
WS-02*	594.00	535	0.00	0	535	594	0.90	1.00	100%
WS-03*	800.00	720	0.00	0	720	800	0.90	1.00	100%
WS-04*	418.00	376	0.00	0	376	418	0.90	1.00	100%
WS-05	330.00	297	112.00	22	319	442	0.72	0.90	75%
WS-06	1025.00	923	119.00	24	946	1144	0.83	1.00	90%
WS-07	1809.00	1628	75.00	15	1643	1884	0.87	1.00	96%
WS-08	868.00	781	75.00	15	796	943	0.84	1.00	92%
WS-09	791.00	712	159.00	32	744	950	0.78	0.98	83%
WS-10	661.00	595	20.00	4	599	681	0.88	1.00	97%
WS-11	176.00	158	45.00	9	167	221	0.76	0.95	80%
WS-12	47.00	42	35.00	7	49	82	0.60	0.75	57%
WS-13	0.00	0	122.00	24	24	122	0.20	0.25	0%
WS-14	0.00	0	288.00	58	58	288	0.20	0.25	0%
WS-15	1017.00	915	262.00	52	968	1279	0.76	0.95	80%
WS-16	1108.00	997	209.00	42	1039	1317	0.79	0.99	84%
WS-17	229.00	206	0.00	0	206	229	0.90	1.00	100%
WS-Unc**	113.00	102	200.00	40	142	313	0.45	0.57	36%
<b>Total***</b>	<b>11220</b>		<b>1521</b>		<b>10402</b>	<b>13283</b>			

\* Roof top storage Areas

\*\*Uncontrolled Areas

\*\*\*Area Based on Future Property Line

**TABLE III - TOTAL RUNOFF COEFFICIENT FOR CONTROLLED AREAS (EXCLUDING ROOF TOP AREAS)**

$C_{AVG(5yr)} = \frac{\text{Sum AC}}{\text{Total Area}} = \frac{7\ 559}{9\ 582} = 0.79$	$C_{AVG(100yr)} = 0.99$
---	-------------------------

**TABLE IV - SUMMARY OF POST-DEVELOPMENT RUNOFF**

Area No	Area (ha)	Storm = 5 yr				Storm = 100 yr			
		I <sub>5</sub> (mm/hr)	C <sub>AVG</sub> (5yr)	Q <sub>GEN</sub> (L/s)	Q <sub>CONT</sub> (L/s)	I <sub>100</sub> (mm/hr)	C <sub>AVG</sub> (100yr)	Q <sub>GEN</sub> (L/s)	Q <sub>CONT</sub> (L/s)
WS-01*	0.158	104.19	0.90	41.1		178.56	1.00	78.2	
WS-02*	0.059	104.19	0.90	15.5		178.56	1.00	29.5	
WS-03*	0.080	104.19	0.90	20.9		178.56	1.00	39.7	
WS-04*	0.042	104.19	0.90	10.9		178.56	1.00	20.7	
WS-05	0.044	104.19	0.72	9.3		178.56	0.90	19.8	
WS-06	0.114	104.19	0.83	27.4		178.56	1.00	56.8	
WS-07	0.188	104.19	0.87	47.6		178.56	1.00	93.5	
WS-08	0.094	104.19	0.84	23.1		178.56	1.00	46.8	
WS-09	0.095	104.19	0.78	21.5		178.56	0.98	46.1	
WS-10	0.068	104.19	0.88	17.3		178.56	1.00	33.8	
WS-11	0.022	104.19	0.76	4.8		178.56	0.95	10.4	
WS-12	0.008	104.19	0.60	1.4		178.56	0.75	3.1	
WS-13	0.012	104.19	0.20	0.7		178.56	0.25	1.5	
WS-14	0.029	104.19	0.20	1.7		178.56	0.25	3.6	
WS-15	0.128	104.19	0.76	28.0		178.56	0.95	60.0	
WS-16	0.132	104.19	0.79	30.1		178.56	0.99	64.5	
WS-17	0.023	104.19	0.90	6.0		178.56	1.00	11.4	
WS-Unc**	0.031	104.19	0.45	4.1	<b>4.1</b>	178.56	0.57	8.8	<b>8.8</b>
<b>Total</b>	<b>1.328</b>			<b>311.4</b>				<b>628.274</b>	<b>316.1</b>

\* Roof top storage Areas

$$I_5 = 998.071 / (Tc+6.053)^{0.814}$$

$$I_{100} = 1735.688 / (Tc+6.014)^{0.820}$$

Time of concentration (min), Tc = 10 mins

**Appendix B:  
Storm and Sanitary Sewer Computation Forms**

## STORM SEWER COMPUTATION FORM

**Rational Method**  
 $Q = 2.78 \cdot A \cdot I \cdot R$   
 Q = Flow (L/sec)  
 A = Area (ha)  
 I = Rainfall Intensity (mm/h)  
 R = Ave. Runoff Coefficient

**City of Ottawa IDF Curve - 5-y**  
 $I_5 = 998.071 / (T_c + 6.053)^{0.814}$   
 Minimum Time of Conc.  $T_c = 10 \text{ min}$

Manning's  $n = 0.013$

Drainage Area	From	To	Area (ha)	Runoff Parameters					Roof Flow Q (L/sec)	Peak Flow Q (L/sec)	Pipe Dia.		Slope (%)	Length (m)	Capacity full (L/sec)	Velocity		Time of Flow (min)	Q(d) / Q(f)	REMARKS
				Runoff Coeff. R	Indiv. 2.78AR	Accum. 2.78AR	Time of Conc. (min)	Rainfall Intensity (mm/hr)			nom. (mm)	actual (mm)				full (m/sec)	actual (m/sec)			
WS-14	RY-CB-15 MHST-14	MHST-14 CBMH-13	0.029	0.20	0.02	0.02	10.00 10.16	104.19 103.36	1.67 1.66	250 254	254 254	2.00	16.2 22.5	87.74 87.74	1.73 1.73	0.64 0.64	0.16 0.22	0.02		
WS-01 & WS-02	MHST-17	CBMH-13					10.00		11.95	11.95	250	254	0.66	32.5	50.40	0.99	0.68	0.54	0.24	Roof Flow from PCSWMM
WS-09 & WS-10	CBMH-13	MHST-9	0.163	0.82	0.37	0.39	10.38	102.23	11.95	51.74	375	381	0.25	26.7	91.46	0.80	0.71	0.55	0.57	
WS-13	RY-CB-11 MHST-10	MHST-10 MHST-9	0.012	0.20	0.007	0.007	10.00 10.13	104.19 103.51	0.71 0.70	250 250	254 254	2.00	13.9 23.8	87.74 87.74	1.73 1.73	0.55 0.55	0.13 0.23	0.01	0.01	
	MHST-9	MHST-8				0.40	10.93	99.52	11.95	51.37	450	457	0.20	7.6	133.02	0.81	0.63	0.16	0.39	
WS-15	CB-19	CBMH-16	0.128	0.76	0.269	0.269	10.00	104.19	28.03	250	254	2.00	19.9	87.74	1.73	1.28	0.19	0.32		
WS-17	TD-CB-25	CBMH-16	0.023	0.90	0.057	0.057	10.00	104.19	5.97	200	203	2.00	29.9	48.39	1.49	0.85	0.33	0.12		
WS-16	CBMH-16	MHST-18	0.132	0.79	0.289	0.615	10.33	102.48	63.04	375	381	0.30	20.3	100.18	0.88	0.80	0.39	0.63		
WS-06	MHST-18	MHST-3	0.114	0.83	0.263	0.878	10.72	100.54	88.30	450	457	0.20	51.3	133.02	0.81	0.75	1.06	0.66		
WS-05	MHST-3	MHST-8	0.044	0.72	0.089	0.967	11.78	95.65	92.49	450	457	0.20	63.0	133.02	0.81	0.77	1.30	0.70		
WS-07, WS-08 & WS-11	MHST-8	MHST-6	0.305	0.86	0.725	2.088	13.08	90.32	11.95	200.52	600	610	0.20	26.3	286.47	0.98	0.93	0.45	0.70	
WS-03, WS-04 & WS-12	MHST-6	EX. CBMH	0.008	0.60	0.014	2.101	13.53	88.63	19.08	205.33	600	610	0.20	4.4	286.47	0.98	0.94	0.07	0.72	Roof Flow from PCSWMM

Note:

**Design:** B. Villeneuve  
**Check:** M. Theiner  
**Date:** 2023-10-16

**Project:** 3850 Cambrian Rd  
 Commercial Development  
**Client:** Choice Properties



# SANITARY SEWER DESIGN SHEET

Drainage Area	From	To	Peak Flow Q (L/sec)	Sewer Data										REMARKS
				Type of Pipe	Pipe Dia.		Slope (%)	Length (m)	Capacity full (L/sec)	Velocity		Time of Flow (min)	Q(d) / Q(f)	
					nom. (mm)	actual (mm)				full (m/sec)	actual (m/sec)			
	MHSA-1	MHSA-2	0.55	PVC	150	152.4	2.45	25.0	24.9	1.36	0.60	0.69	0.02	Bldg A&B Connections + Infiltration
	MHSA-2	EX MH-S-1	0.61	PVC	150	152.4	2.45	55.3	24.9	1.36	0.60	1.54	0.02	Bldg C&D Connections
	EX MH-S-1	EX MH-S-2	0.61	PVC	200	203.2	2.20	25.3	50.8	1.56	0.64	0.66	0.01	
	EX MH-S-2	EX MH-S	97.94	CONC	500	500	0.13	167.5	136.1	0.69	0.67	4.19	0.72	*From DSEL Report

Manning's n = 0.013

<b>Design:</b> BV	<b>Project Name:</b> 3850 Cambrian Road
<b>Check:</b> MT	<b>Parsons Project #:</b> 478356
<b>Date:</b> October 2023	<b>Client:</b> Choice Properties
	<b>Client Project #:</b>

**Appendix C:  
Sanitary Load and Fire Flow**

# SANITARY DESIGN FLOWS

Area	COMMERCIAL/RETAIL			TOTAL	INFILTRATION			Total
	Retail Area	Peak Factor	Peak Flow	Peak Flow	Site Area	Infiltration Allowance	Infil. Flow	Total Peak Flow
	(m <sup>2</sup> )		(L/s)	(L/s)	(ha)	(L/s/ha)	(L/s)	(L/s)
<b>Subject Site</b>					1.36	0.33	0.45	0.45
<b>Bldg A</b>	1 576	1.5	0.08	0.08				0.08
<b>Bldg B</b>	576	1.5	0.03	0.03				0.03
<b>Bldg C</b>	798	1.5	0.04	0.04				0.04
<b>Bldg D</b>	418	1.5	0.02	0.02				0.02
							<b>Total</b>	<b>0.61</b>

## Average Daily Demands

(Based on City of Ottawa Sewer Design Guidelines 2012 and MOE Water Design Guidelines)

Average Residential Daily Flow =	280 L/p/d
Institutional Flow =	28 000 L/ha/d
Commercial Flow =	28 000 L/ha/d
Light Industrial Flow =	35 000 L/ha/d
Heavy Industrial Flow =	55 000 L/ha/d
Hotel Daily Flow =	225 L/bed/d
Office/Warehouse Daily Flow =	75 L/empl/d
Shopping Centres =	2 500 L/(1000m <sup>2</sup> /d)

## Population Densities

Average suburban residential dev.	60 p/ha
Single family	3.4 p./unit
Semi-detached	2.7 p./unit
Duplex	2.3 p./unit
Townhouse	2.7 p./unit
Appartment average	1.8 p./unit
Bachelor	1.4 p./unit
1 Bedroom	1.4 p./unit
2 Bedrooms	2.1 p./unit
3 Bedrooms	3.1 p./unit
Hotel room, 18 m2	1 p./unit
Restaurant, 1 m2	1 p./unit
Office	1 p/25m <sup>2</sup>
Warehouse	1 p/90m <sup>2</sup>
Automotive Service Centre, per bay	1 p/bay (plus management)

## Peak Factors

Commercial =	1.5 if commercial contribution > 20%, otherwise
Institutional =	1.5 if institutional contribution > 20%, otherwise
Industrial =	per Appendix 4-B.0 Graph
Residential :	Harmon Equation
	$1 + (14/(4+(Capita/1000)^{0.5})) * 8$
	min = 2
	max = 4

Infiltration allowance (dry weather)	0.05 L/s/ha
Infiltration allowance (wet weather)	0.28 L/s/ha

I/I (total) 0.33 L/s/ha

<b>Design:</b>	BV	<b>Project:</b>	Commercial Development Choice Properties
<b>Check :</b>	MT	<b>Location:</b>	3850 Cambrian Road Ottawa, Ontario
<b>Dwg reference:</b>		<b>Project # :</b>	478356
		<b>Date:</b>	March 2023
		<b>Sheet:</b>	1 of 1

## 3850 Cambrian Road Commercial Development - Estimated Water Demands

Area	Units	Population	Gross Floor Area (m <sup>2</sup> )	Average Daily Demand (ADD) (L/s)	Maximum Daily Demand (MDD) (L/s)	Peak Hourly Demand (PHD) (L/s)	Fire Flow (FF) (L/s)	MDD + FF (L/s)
<b>Proposed Bldg A</b>								
Commercial Unit			1576	0.05	0.08	0.14	100	100.08
<b>Proposed Bldg B</b>								
Commercial Unit			576	0.02	0.03	0.05	50	50.03
<b>Proposed Bldg C</b>								
Commercial Unit			798	0.03	0.04	0.07	100	100.04
<b>Proposed Bldg D</b>								
Commercial Unit			418	0.01	0.02	0.04	83	83.02

### Average Daily Demand

Based on Ottawa Design Guidelines - Water Distribution, 2010 and MOE Design Guidelines for Drinking-Water Systems, 2008

Average Residential Daily Flow =	350 L/p/d
Institutional Flow =	28 000 L/gross ha/d
Commercial Flow =	28 000 L/gross ha/d
Light Industrial Flow =	35 000 L/gross ha/d
Heavy Industrial Flow =	55 000 L/gross ha/d
Hotel Daily Flow =	225 L/bed/d
Office/Warehouse Daily Flow =	75 L/person/d
Office/Warehouse Daily Flow =	8.06 L/m <sup>2</sup> /day
Restaurant (Ordinary not 24 Hours) =	125 L/seat/d
Restaurant (24 Hours) =	200 L/seat/d
Shopping Centres =	2 500 L/(1000m <sup>2</sup> /d)
Amenity Area =	5 L/m <sup>2</sup> /d

### **Maximum Daily Demand**

Residential = 2.5 x Average Daily Demand
4.9 x Average Daily Demand **
Industrial = 1.5 x Average Daily Demand
Commercial = 1.5 x Average Daily Demand
Institutional = 1.5 x Average Daily Demand

### **Peak Hourly Demand**

Residential = 2.2 x Maximum Daily Demand
7.4 x Maximum Daily Demand **
Industrial = 1.8 x Maximum Daily Demand
Commercial = 1.8 x Maximum Daily Demand
Institutional = 1.8 x Maximum Daily Demand

3850 Cambrian Road Commercial Development

Building	Type of Construction	Total Floor Area (m <sup>2</sup> )	Fire Flow (min. 2,000) (L/min)	Adjusted (nearest 1,000) (L/min)	Occupancy Factor	Reduction / Increase due to Occupancy	Fire Flow with Occupancy (min. 2,000) (L/min)	Sprinklers Factor	Reduction due to Sprinklers (L/min)	Exposure Factor %	Increase due to Exposure (L/min)	Fire Flow (L/min)	Roof Contribution (L/min)	Required Fire Demand	
														Adjusted to the nearest 1000 (min. 2,000, max. 45,000) (L/min)	Minimum 33 (L/s)
	C	A	F		O			S		E			R	F	
Bldg A	0.8	1 576	6 987	7 000	0%	0	7 000	50%	3 500	40%	2 800	6 000	0	6 000	100
Bldg B	0.8	576	4 224	4 000	0%	0	4 000	50%	2 000	35%	1 400	3 000	0	3 000	50
Bldg C	0.8	798	4 972	5 000	0%	0	5 000	0%	0	15%	750	6 000	0	6 000	100
Bldg D	0.8	418	3 998	4 000	0%	0	4 000	0%	0	15%	600	5 000	0	5 000	83

References

Water Supply for Public Fire Protection, 2020 by Fire Underwriters Survey (FUS) and Ottawa Design Guidelines - Water Distribution, July 2010 and subsequent Technical Bulletins

C Type of Construction

Wood Frame (Type V)	1.5
Mass Timber (Type IV-A) - Encapsulated Mass Timber	0.8
Mass Timber (Type IV-B) - Rated Mass Timber	0.9
Mass Timber (Type IV-C) - Ordinary Mass Timber	1.0
Mass Timber (Type IV-D) - Unrated Mass Timber	1.5
Ordinary Construction (Type III also known as joisted masonry)	1.0
Non-Combustible Construction (Type II - minimum 1 hour fire resistance rating)	0.8
Fire resistive Construction (Type I - minimum 2 hour fire resistance rating)	0.6

S Sprinklers

	Complete Coverage	Partial Coverage
Automatic Sprinklers NFPA Standards	30%	30% + x%
Standard Water Supply	10%	10% + x%
Full Supervision	10%	10% + x%

(x%: percentage of total protected floor area)

Additional Reductions for Community Level Automatic Sprinkler Protection of Area

Buildings located within communities or subdivisions that are completely sprinkler protected may apply up to a maximum additional 25% reduction in required fire flows beyond the normal maximum of 50% reduction for sprinkler protection of an individual building.

Adjustment of Sprinkler Reductions for Community Level Oversight of Sprinkler Maintenance, Testing, and Water Supply Requirements

The reduction in required fire flow for sprinkler protection may be reduced or eliminated if:  
 - The community does not have a Fire Prevention Program that provides a system of ensuring that the fire sprinkler systems are inspected, tested, and maintained in accordance with NFPA 25  
 - The community does not maintain the pressure and flow rate requirements for fire sprinkler installations, or otherwise allows the flow rates and pressure levels that were available during sprinkler system design to significantly degrade, increasing the probability of inadequate water supply for effective sprinkler operation.

A Total Effective Floor Area (m<sup>2</sup>)

Buildings Classified with a Construction Coefficient from 1.0 to 1.5  
 100% of all Floor Areas

Buildings Classified with a Construction Coefficient below 1.0  
 Vertical Openings Unprotected  
 Two (2) Largest Adjoining Floor Areas  
 Additional Floors (up to eight (8)) at 50%

Vertical Openings Properly Protected  
 Single Largest Floor  
 Additional Two (2) Adjoining Floors at 25%

High One Storey Building

When a building has a large single storey space exceeding 3m in height, the number of storeys to be used in determining the total effective area depends upon the use being made of the building.

Subdividing Buildings (Vertical Firewalls)

Minimum two (2) hour fire resistance rating and meets National Building Code requirements.  
 - Up to 10% can be applied if there is severe risk of fire on the exposed side of the firewall due to hazard conditions.  
 - An exposure charge of up to 10% can be applied if there are unprotected openings in the firewall

Basement

Basement floor excluded when it is at least 50% below grade.

Open Parking Garages

Use the area of the largest floor.

O Occupancy

Non-Combustible	-25%
Limited Combustible	-15%
Combustible	0%
Free Burning	15%
Rapid Burning	25%

- Table 3 provides recommended Occupancy and Contents Adjustment Factors for Example Major Occupancies from the National Building Code of Canada.  
 - Adjustment factors should be adjusted accordingly to the specific fire loading and situation that exists in the subject building.  
 - Values can be interpolated from the examples given considering fire loading and expected combustibility of contents if the subject building is not listed.  
 - Values can be modified by up to 10% (+/-) depending on the extent to which the fire loading is unusual for the building.  
 - Buildings with multiple major occupancies should use the most restrictive factor or interpolate based on the percentage of each occupancy and its associated fire loading.

Table 3 Values for Subject Building

Group:	
Division:	
Description of Occupancy:	
Occupancy and Contents:	
Adjustment Factor:	0%

R Roof

Shake Roof	2,000 to 4,000 L/min	additional should be added to the fire flow
Wood Shingle	2,000 to 4,000 L/min	additional should be added to the fire flow

F Fire Flow (L/Min)

220 \* C \* (A^0.5)

E Exposure

The maximum exposure adjustment that can be applied to a building is 75% when summing the percentages of all sides of the building

Separation Distance (m)	Maximum Exposure Adjustment	N	E	S	W
0 to 3	25%		BldgB		BldgA
3.1 to 10	20%				
10.1 to 20	15%	BldgA	BldgC		BldgD
20.1 to 30	10%				BldgB
Greater than 30	0%				

Table 6: Exposure Adjustment Charges for Subject Building Considering Construction Type of Exposed Building Face

Distance to the Exposure (m)	Length-Height Factor of Exposing Building Face	Type				
		Type V	Type III-IV <sup>2</sup>	Type III-IV <sup>3</sup>	Type I-II <sup>2</sup>	Type I-II <sup>3</sup>
0 to 3	0-20	20%	15%	5%	10%	0%
	21-40	21%	16%	6%	11%	1%
	41-60	22%	17%	7%	12%	2%
	61-80	23%	18%	8%	13%	3%
	81-100	24%	19%	9%	14%	4%
	Over 100	25%	20%	10%	15%	5%
3.1 to 10	0-20	15%	10%	3%	6%	0%
	21-40	16%	11%	4%	7%	0%
	41-60	17%	12%	5%	8%	1%
	61-80	18%	13%	6%	9%	2%
	81-100	19%	14%	7%	10%	3%
	Over 100	20%	15%	8%	11%	4%
10.1 to 20	0-20	10%	6%	0%	3%	0%
	21-40	11%	6%	1%	4%	0%
	41-60	12%	7%	2%	5%	0%
	61-80	13%	8%	3%	6%	1%
	81-100	14%	9%	4%	7%	2%
	Over 100	15%	10%	5%	8%	3%
20.1 to 30	0-20	0%	0%	0%	0%	0%
	21-40	2%	1%	0%	0%	0%
	41-60	4%	2%	0%	1%	0%
	61-80	6%	3%	1%	2%	0%
	81-100	8%	4%	2%	3%	0%
	Over 100	10%	5%	3%	4%	0%
Over 30m	All Sizes	0%	0%	0%	0%	0%

<sup>2</sup> with unprotected openings

<sup>3</sup> without unprotected openings

Automatic Sprinkler Protection in Exposed Buildings

If the exposed building is fully protected with an automatic sprinkler system (see note Recognition of Automatic Sprinkler), the exposure adjustment charge determined from Table 6 may be reduced by up to 50% of the value determined.

Automatic Sprinkler Protection in Both Subject and Exposed Buildings

If both the subject building and the exposed building are fully protected with automatic sprinkler systems (see note Recognition of Automatic Sprinkler), no exposure adjustment charge should be applied.

Exposure Protection of Area Between Subject and Exposed Buildings

If the exposed building is fully protected with an automatic sprinkler system (see note Recognition of Automatic Sprinkler), and the area between the buildings is protected with an exterior automatic sprinkler system, no exposure adjustment charge should be applied.

Reduction of Exposure Charge for Type V Buildings

If the exposed building face of a Type V building has an exterior cladding assembly with a minimum 1 hour fire resistive rating, then the exposure charge may be treated as a Type III/IV building for the purposes of looking up the appropriate exposure charge in Table 6.

**Appendix D:  
WaterCad Model Results**

# Scenario: Base

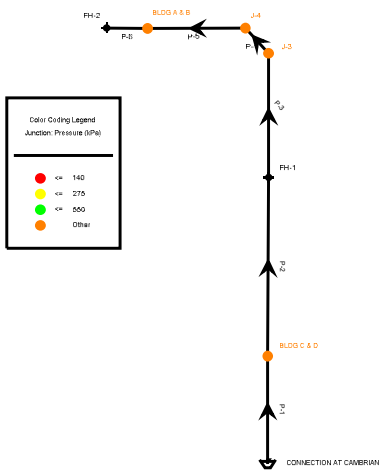

## AVERAGE DAY RESULTS

### PIPE TABLE

Length (Scaled) (m)	Start Node	Stop Node	Diameter (mm)	Material	Hazen-Williams C	Flow (L/s)	Velocity (m/s)
19	CONNECTION AT CAMBRIAN	BLDG C & D	200.0	PVC	110.0	0.11	0.00
31	BLDG C & D	FH-1	200.0	PVC	110.0	0.07	0.00
21	FH-1	J-3	200.0	PVC	110.0	0.07	0.00
6	J-3	J-4	200.0	PVC	110.0	0.07	0.00
17	J-4	BLDG A & B	200.0	PVC	110.0	0.07	0.00
7	BLDG A & B	FH-2	200.0	PVC	110.0	0.00	0.00

### JUNCTION TABLE

Label	Elevation (m)	Demand (L/s)	Hydraulic Grade (m)	Pressure (kPa)
BLDG C & D	94.10	0.04	156.50	611
J-3	93.60	0.00	156.50	616
J-4	93.60	0.00	156.50	616
BLDG A & B	93.92	0.07	156.50	612

### RESERVOIR TABLE

Label	Elevation (m)	Flow (Out net) (L/s)	Hydraulic Grade (m)
CONNECTION AT CAMBRIAN	156.50	0.11	156.50



# Scenario: Peak Hour

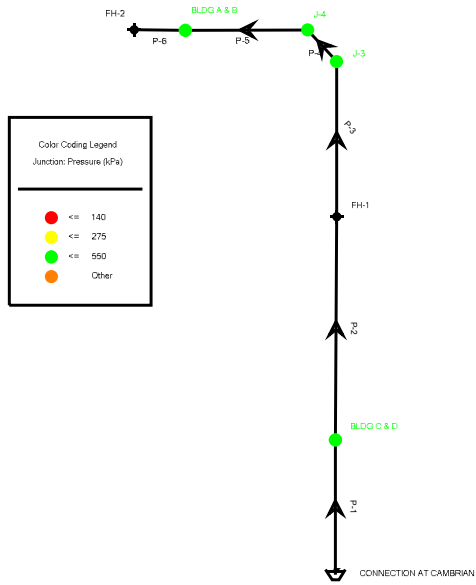

## PEAK HOUR RESULTS

### PIPE TABLE

Length (Scaled) (m)	Start Node	Stop Node	Diameter (mm)	Material	Hazen-Williams C	Flow (L/s)	Velocity (m/s)
19	CONNECTION AT CAMBRIAN	BLDG C & D	200.0	PVC	110.0	0.31	0.01
31	BLDG C & D	FH-1	200.0	PVC	110.0	0.20	0.01
21	FH-1	J-3	200.0	PVC	110.0	0.20	0.01
6	J-3	J-4	200.0	PVC	110.0	0.20	0.01
17	J-4	BLDG A & B	200.0	PVC	110.0	0.20	0.01
7	BLDG A & B	FH-2	200.0	PVC	110.0	0.00	0.00

### JUNCTION TABLE

Label	Elevation (m)	Demand (L/s)	Hydraulic Grade (m)	Pressure (kPa)
BLDG C & D	94.10	0.11	142.60	475
J-3	93.60	0.00	142.60	480
J-4	93.60	0.00	142.60	480
BLDG A & B	93.92	0.20	142.60	476

### RESERVOIR TABLE

Label	Elevation (m)	Flow (Out net) (L/s)	Hydraulic Grade (m)
CONNECTION AT CAMBRIAN	142.60	0.31	142.60

# Scenario: Max Day + FF

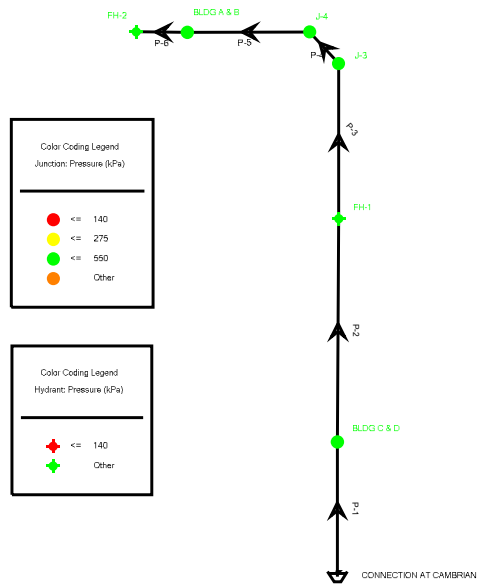

## MAX DAY + FIRE FLOW RESULTS

### HYDRANT TABLE

Label	Length (Hydrant Lateral) (m)	Elevation (m)	Demand (L/s)	Hydraulic Grade (m)	Pressure (kPa)
FH-2	6	93.60	95.00	131.31	369
FH-1	6	93.85	5.00	135.77	410

### PIPE TABLE

Length (Scaled) (m)	Start Node	Stop Node	Diameter (mm)	Material	Hazen-Williams C	Flow (L/s)	Velocity (m/s)
19	CONNECTION AT CAMBRIAN	BLDG C & D	200.0	PVC	110.0	100	3.19
31	BLDG C & D	FH-1	200.0	PVC	110.0	100	3.19
21	FH-1	J-3	200.0	PVC	110.0	95	3.03
6	J-3	J-4	200.0	PVC	110.0	95	3.03
17	J-4	BLDG A & B	200.0	PVC	110.0	95	3.03
7	BLDG A & B	FH-2	200.0	PVC	110.0	95	3.02

### JUNCTION TABLE

Label	Elevation (m)	Demand (L/s)	Hydraulic Grade (m)	Pressure (kPa)
BLDG C & D	94.10	0.06	137.72	427
J-3	93.60	0.00	134.54	401
J-4	93.60	0.00	134.20	397
BLDG A & B	93.92	0.11	133.23	385

### RESERVOIR TABLE

Label	Elevation (m)	Flow (Out net) (L/s)	Hydraulic Grade (m)
CONNECTION AT CAMBRIAN	138.90	100.17	138.90

**Appendix E:**  
**Stormwater Storage Chambers Specifications**

PROJECT INFORMATION	
ENGINEERED PRODUCT MANAGER	
ADS SALES REP	
PROJECT NO.	



# 3850 CAMBRIAN RD FOR PCSWMM

## OTTAWA, ON, CANADA

### SC-310 STORMTECH CHAMBER SPECIFICATIONS

- CHAMBERS SHALL BE STORMTECH SC-310.
- CHAMBERS SHALL BE ARCH-SHAPED AND SHALL BE MANUFACTURED FROM VIRGIN, IMPACT-MODIFIED POLYPROPYLENE OR POLYETHYLENE COPOLYMERS.
- CHAMBERS SHALL BE CERTIFIED TO CSA B184, "POLYMERIC SUB-SURFACE STORMWATER MANAGEMENT STRUCTURES", AND MEET THE REQUIREMENTS OF ASTM F2922 (POLETHYLENE) OR ASTM F2418 (POLYPROPYLENE), "STANDARD SPECIFICATION FOR CORRUGATED WALL STORMWATER COLLECTION CHAMBERS".
- CHAMBER ROWS SHALL PROVIDE CONTINUOUS, UNOBSTRUCTED INTERNAL SPACE WITH NO INTERNAL SUPPORTS THAT WOULD IMPEDE FLOW OR LIMIT ACCESS FOR INSPECTION.
- THE STRUCTURAL DESIGN OF THE CHAMBERS, THE STRUCTURAL BACKFILL, AND THE INSTALLATION REQUIREMENTS SHALL ENSURE THAT THE LOAD FACTORS SPECIFIED IN THE AASHTO LRFD BRIDGE DESIGN SPECIFICATIONS, SECTION 12.12, ARE MET FOR: 1) LONG-DURATION DEAD LOADS AND 2) SHORT-DURATION LIVE LOADS, BASED ON THE CSA S6 CL-625 TRUCK AND THE AASHTO DESIGN TRUCK WITH CONSIDERATION FOR IMPACT AND MULTIPLE VEHICLE PRESENCES.
- CHAMBERS SHALL BE DESIGNED, TESTED AND ALLOWABLE LOAD CONFIGURATIONS DETERMINED IN ACCORDANCE WITH ASTM F2787, "STANDARD PRACTICE FOR STRUCTURAL DESIGN OF THERMOPLASTIC CORRUGATED WALL STORMWATER COLLECTION CHAMBERS". LOAD CONFIGURATIONS SHALL INCLUDE: 1) INSTANTANEOUS (<1 MIN) AASHTO DESIGN TRUCK LIVE LOAD ON MINIMUM COVER 2) MAXIMUM PERMANENT (75-YR) COVER LOAD AND 3) ALLOWABLE COVER WITH PARKED (1-WEEK) AASHTO DESIGN TRUCK.
- REQUIREMENTS FOR HANDLING AND INSTALLATION:
  - TO MAINTAIN THE WIDTH OF CHAMBERS DURING SHIPPING AND HANDLING, CHAMBERS SHALL HAVE INTEGRAL, INTERLOCKING STACKING LUGS.
  - TO ENSURE A SECURE JOINT DURING INSTALLATION AND BACKFILL, THE HEIGHT OF THE CHAMBER JOINT SHALL NOT BE LESS THAN 50 mm (2").
  - TO ENSURE THE INTEGRITY OF THE ARCH SHAPE DURING INSTALLATION, a) THE ARCH STIFFNESS CONSTANT AS DEFINED IN SECTION 6.2.8 OF ASTM F2922 SHALL BE GREATER THAN OR EQUAL TO 400 LBS/FT/%. AND b) TO RESIST CHAMBER DEFORMATION DURING INSTALLATION AT ELEVATED TEMPERATURES (ABOVE 23° C / 73° F), CHAMBERS SHALL BE PRODUCED FROM REFLECTIVE GOLD OR YELLOW COLORS.
- ONLY CHAMBERS THAT ARE APPROVED BY THE SITE DESIGN ENGINEER WILL BE ALLOWED. UPON REQUEST BY THE SITE DESIGN ENGINEER OR OWNER, THE CHAMBER MANUFACTURER SHALL SUBMIT A STRUCTURAL EVALUATION FOR APPROVAL BEFORE DELIVERING CHAMBERS TO THE PROJECT SITE AS FOLLOWS:
  - THE STRUCTURAL EVALUATION SHALL BE SEALED BY A REGISTERED PROFESSIONAL ENGINEER.
  - THE STRUCTURAL EVALUATION SHALL DEMONSTRATE THAT THE SAFETY FACTORS ARE GREATER THAN OR EQUAL TO 1.95 FOR DEAD LOAD AND 1.75 FOR LIVE LOAD, THE MINIMUM REQUIRED BY ASTM F2787 AND BY SECTIONS 3 AND 12.12 OF THE AASHTO LRFD BRIDGE DESIGN SPECIFICATIONS FOR THERMOPLASTIC PIPE.
  - THE TEST DERIVED CREEP MODULUS AS SPECIFIED IN ASTM F2922 SHALL BE USED FOR PERMANENT DEAD LOAD DESIGN EXCEPT THAT IT SHALL BE THE 75-YEAR MODULUS USED FOR DESIGN.
- CHAMBERS AND END CAPS SHALL BE PRODUCED AT AN ISO 9001 CERTIFIED MANUFACTURING FACILITY.

### IMPORTANT - NOTES FOR THE BIDDING AND INSTALLATION OF THE SC-310 SYSTEM

- STORMTECH SC-310 CHAMBERS SHALL NOT BE INSTALLED UNTIL THE MANUFACTURER'S REPRESENTATIVE HAS COMPLETED A PRE-CONSTRUCTION MEETING WITH THE INSTALLERS.
- STORMTECH SC-310 CHAMBERS SHALL BE INSTALLED IN ACCORDANCE WITH THE "STORMTECH SC-310/SC-740/DC-780 CONSTRUCTION GUIDE".
- CHAMBERS ARE NOT TO BE BACKFILLED WITH A DOZER OR AN EXCAVATOR SITUATED OVER THE CHAMBERS. STORMTECH RECOMMENDS 3 BACKFILL METHODS:
  - STONESHOOTER LOCATED OFF THE CHAMBER BED.
  - BACKFILL AS ROWS ARE BUILT USING AN EXCAVATOR ON THE FOUNDATION STONE OR SUBGRADE.
  - BACKFILL FROM OUTSIDE THE EXCAVATION USING A LONG BOOM HOE OR EXCAVATOR.
- THE FOUNDATION STONE SHALL BE LEVELED AND COMPACTED PRIOR TO PLACING CHAMBERS.
- JOINTS BETWEEN CHAMBERS SHALL BE PROPERLY SEATED PRIOR TO PLACING STONE.
- MAINTAIN MINIMUM - 150 mm (6") SPACING BETWEEN THE CHAMBER ROWS.
- EMBEDMENT STONE SURROUNDING CHAMBERS MUST BE A CLEAN, CRUSHED, ANGULAR STONE 20-50 mm (3/4-2").
- THE CONTRACTOR MUST REPORT ANY DISCREPANCIES WITH CHAMBER FOUNDATION MATERIALS BEARING CAPACITIES TO THE SITE DESIGN ENGINEER.
- ADS RECOMMENDS THE USE OF "FLEXSTORM CATCH IT" INSERTS DURING CONSTRUCTION FOR ALL INLETS TO PROTECT THE SUBSURFACE STORMWATER MANAGEMENT SYSTEM FROM CONSTRUCTION SITE RUNOFF.

### NOTES FOR CONSTRUCTION EQUIPMENT

- STORMTECH SC-310 CHAMBERS SHALL BE INSTALLED IN ACCORDANCE WITH THE "STORMTECH SC-310/SC-740/DC-780 CONSTRUCTION GUIDE".
- THE USE OF CONSTRUCTION EQUIPMENT OVER SC-310 & SC-740 CHAMBERS IS LIMITED:
  - NO EQUIPMENT IS ALLOWED ON BARE CHAMBERS.
  - NO RUBBER TIRE LOADERS, DUMP TRUCKS, OR EXCAVATORS ARE ALLOWED UNTIL PROPER FILL DEPTHS ARE REACHED IN ACCORDANCE WITH THE "STORMTECH SC-310/SC-740/DC-780 CONSTRUCTION GUIDE".
  - WEIGHT LIMITS FOR CONSTRUCTION EQUIPMENT CAN BE FOUND IN THE "STORMTECH SC-310/SC-740/DC-780 CONSTRUCTION GUIDE".
- FULL 900 mm (36") OF STABILIZED COVER MATERIALS OVER THE CHAMBERS IS REQUIRED FOR DUMP TRUCK TRAVEL OR DUMPING.

**USE OF A DOZER TO PUSH EMBEDMENT STONE BETWEEN THE ROWS OF CHAMBERS MAY CAUSE DAMAGE TO THE CHAMBERS AND IS NOT AN ACCEPTABLE BACKFILL METHOD. ANY CHAMBERS DAMAGED BY THE "DUMP AND PUSH" METHOD ARE NOT COVERED UNDER THE STORMTECH STANDARD WARRANTY.**

CONTACT STORMTECH AT 1-888-892-2694 WITH ANY QUESTIONS ON INSTALLATION REQUIREMENTS OR WEIGHT LIMITS FOR CONSTRUCTION EQUIPMENT.

PROPOSED LAYOUT		PROPOSED ELEVATIONS:		*INVERT ABOVE BASE OF CHAMBER				
72	STORMTECH SC-310 CHAMBERS	MAXIMUM ALLOWABLE GRADE (TOP OF PAVEMENT/UNPAVED):	94.997	PART TYPE	ITEM ON LAYOUT	DESCRIPTION	INVERT*	MAX FLOW
12	STORMTECH SC-310 END CAPS	MINIMUM ALLOWABLE GRADE (UNPAVED WITH TRAFFIC):	93.168	PREFABRICATED EZ END CAP	A	300 mm BOTTOM PREFABRICATED EZ END CAP, PART#: SC310ECEZ / TYP OF ALL 300 mm BOTTOM CONNECTIONS AND ISOLATOR PLUS ROWS	23 mm	
152	STONE ABOVE (mm)	MINIMUM ALLOWABLE GRADE (UNPAVED NO TRAFFIC):	93.016	FLAMP	B	INSTALL FLAMP ON 300 mm ACCESS PIPE / PART#: SC31012RAMP (TYP 2 PLACES)		
152	STONE BELOW (mm)	MINIMUM ALLOWABLE GRADE (TOP OF RIGID CONCRETE PAVEMENT):	93.016	MANIFOLD	C	300 mm x 300 mm BOTTOM MANIFOLD, ADS N-12	23 mm	
40	STONE VOID	MINIMUM ALLOWABLE GRADE (BASE OF FLEXIBLE PAVEMENT):	93.016	CONCRETE STRUCTURE	D	(DESIGN BY ENGINEER / PROVIDED BY OTHERS)		150 L/s IN
70.1	INSTALLED SYSTEM VOLUME (m <sup>3</sup> ) (PERIMETER STONE INCLUDED) (COVER STONE INCLUDED) (BASE STONE INCLUDED)	TOP OF STONE:	92.711	CONCRETE STRUCTURE	E	(DESIGN BY ENGINEER / PROVIDED BY OTHERS)		
		TOP OF SC-310 CHAMBER:	92.559	CONCRETE STRUCTURE	F	(DESIGN BY ENGINEER / PROVIDED BY OTHERS)		
		300 mm x 300 mm BOTTOM MANIFOLD INVERT:	92.175	W/WEIR				
		300 mm ISOLATOR ROW PLUS INVERT:	92.175					
182.9	SYSTEM AREA (m <sup>2</sup> )	300 mm ISOLATOR ROW PLUS INVERT:	92.175					
69.4	SYSTEM PERIMETER (m)	300 mm ISOLATOR ROW PLUS INVERT:	92.175					
		BOTTOM OF SC-310 CHAMBER:	92.152					
		BOTTOM OF STONE:	92.000					

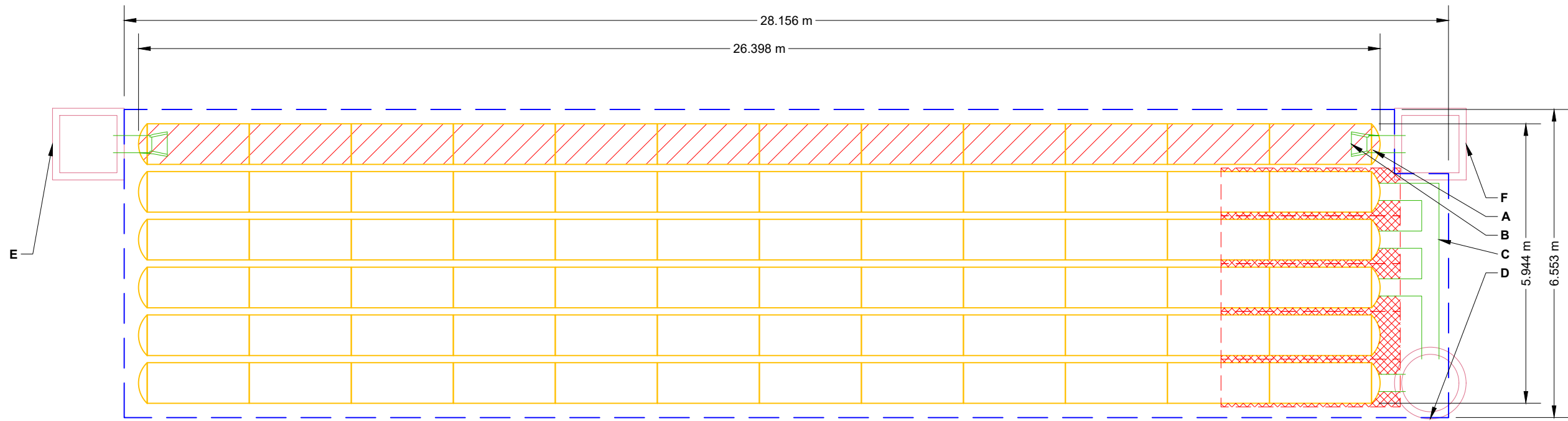

- ISOLATOR ROW PLUS (SEE DETAIL)
- PLACE MINIMUM 3.810 m OF ADSPLUS125 WOVEN GEOTEXTILE OVER BEDDING STONE AND UNDERNEATH CHAMBER FEET FOR SCOUR PROTECTION AT ALL CHAMBER INLET ROWS
- BED LIMITS

**NOTES**

- MANIFOLD SIZE TO BE DETERMINED BY SITE DESIGN ENGINEER. SEE TECH NOTE #6.32 FOR MANIFOLD SIZING GUIDANCE.
- DUE TO THE ADAPTATION OF THIS CHAMBER SYSTEM TO SPECIFIC SITE AND DESIGN CONSTRAINTS, IT MAY BE NECESSARY TO CUT AND COUPLE ADDITIONAL PIPE TO STANDARD MANIFOLD COMPONENTS IN THE FIELD.
- THE SITE DESIGN ENGINEER MUST REVIEW ELEVATIONS AND IF NECESSARY ADJUST GRADING TO ENSURE THE CHAMBER COVER REQUIREMENTS ARE MET.
- THIS CHAMBER SYSTEM WAS DESIGNED WITHOUT SITE-SPECIFIC INFORMATION ON SOIL CONDITIONS OR BEARING CAPACITY. THE SITE DESIGN ENGINEER IS RESPONSIBLE FOR DETERMINING THE SUITABILITY OF THE SOIL AND PROVIDING THE BEARING CAPACITY OF THE INSITU SOILS. THE BASE STONE DEPTH MAY BE INCREASED OR DECREASED ONCE THIS INFORMATION IS PROVIDED.
- **NOT FOR CONSTRUCTION:** THIS LAYOUT IS FOR DIMENSIONAL PURPOSES ONLY TO PROVE CONCEPT & THE REQUIRED STORAGE VOLUME CAN BE ACHIEVED ON SITE.

3850 CAMBRIAN RD FOR  
PCSWMM  
OTTAWA, ON, CANADA

DATE: \_\_\_\_\_ DRAWN: BU  
PROJECT #: \_\_\_\_\_ CHECKED: N/A

DATE	DRW	CHK	DESCRIPTION

**StormTech®**  
Chamber System

888-892-2694 | WWW.STORMTECH.COM

4640 TRUEMAN BLVD  
HILLIARD, OH 43026  
1-800-733-7473

**SCALE = 1 : 100**

SHEET  
**2 OF 5**

THIS DRAWING HAS BEEN PREPARED BASED ON INFORMATION PROVIDED TO ADS UNDER THE DIRECTION OF THE SITE DESIGN ENGINEER OR OTHER PROJECT REPRESENTATIVE. THE SITE DESIGN ENGINEER SHALL REVIEW THIS DRAWING PRIOR TO CONSTRUCTION. IT IS THE ULTIMATE RESPONSIBILITY OF THE SITE DESIGN ENGINEER TO ENSURE THAT THE PRODUCT(S) DEPICTED AND ALL ASSOCIATED DETAILS MEET ALL APPLICABLE LAWS, REGULATIONS, AND PROJECT REQUIREMENTS.

## ACCEPTABLE FILL MATERIALS: STORMTECH SC-310 CHAMBER SYSTEMS

MATERIAL LOCATION		DESCRIPTION	AASHTO MATERIAL CLASSIFICATIONS	COMPACTION / DENSITY REQUIREMENT
D	<b>FINAL FILL:</b> FILL MATERIAL FOR LAYER 'D' STARTS FROM THE TOP OF THE 'C' LAYER TO THE BOTTOM OF FLEXIBLE PAVEMENT OR UNPAVED FINISHED GRADE ABOVE. NOTE THAT PAVEMENT SUBBASE MAY BE PART OF THE 'D' LAYER.	ANY SOIL/ROCK MATERIALS, NATIVE SOILS, OR PER ENGINEER'S PLANS. CHECK PLANS FOR PAVEMENT SUBGRADE REQUIREMENTS.	N/A	PREPARE PER SITE DESIGN ENGINEER'S PLANS. PAVED INSTALLATIONS MAY HAVE STRINGENT MATERIAL AND PREPARATION REQUIREMENTS.
C	<b>INITIAL FILL:</b> FILL MATERIAL FOR LAYER 'C' STARTS FROM THE TOP OF THE EMBEDMENT STONE ('B' LAYER) TO 18" (450 mm) ABOVE THE TOP OF THE CHAMBER. NOTE THAT PAVEMENT SUBBASE MAY BE A PART OF THE 'C' LAYER.	GRANULAR WELL-GRADED SOIL/AGGREGATE MIXTURES, <35% FINES OR PROCESSED AGGREGATE.  MOST PAVEMENT SUBBASE MATERIALS CAN BE USED IN LIEU OF THIS LAYER.	AASHTO M145 <sup>1</sup> A-1, A-2-4, A-3  OR  AASHTO M43 <sup>1</sup> 3, 357, 4, 467, 5, 56, 57, 6, 67, 68, 7, 78, 8, 89, 9, 10	BEGIN COMPACTIONS AFTER 12" (300 mm) OF MATERIAL OVER THE CHAMBERS IS REACHED. COMPACT ADDITIONAL LAYERS IN 6" (150 mm) MAX LIFTS TO A MIN. 95% PROCTOR DENSITY FOR WELL GRADED MATERIAL AND 95% RELATIVE DENSITY FOR PROCESSED AGGREGATE MATERIALS. ROLLER GROSS VEHICLE WEIGHT NOT TO EXCEED 12,000 lbs (53 kN). DYNAMIC FORCE NOT TO EXCEED 20,000 lbs (89 kN).
B	<b>EMBEDMENT STONE:</b> FILL SURROUNDING THE CHAMBERS FROM THE FOUNDATION STONE ('A' LAYER) TO THE 'C' LAYER ABOVE.	CLEAN, CRUSHED, ANGULAR STONE	AASHTO M43 <sup>1</sup> 3, 357, 4, 467, 5, 56, 57	NO COMPACTION REQUIRED.
A	<b>FOUNDATION STONE:</b> FILL BELOW CHAMBERS FROM THE SUBGRADE UP TO THE FOOT (BOTTOM) OF THE CHAMBER.	CLEAN, CRUSHED, ANGULAR STONE	AASHTO M43 <sup>1</sup> 3, 357, 4, 467, 5, 56, 57	PLATE COMPACT OR ROLL TO ACHIEVE A FLAT SURFACE. <sup>2,3</sup>

**PLEASE NOTE:**

- THE LISTED AASHTO DESIGNATIONS ARE FOR GRADATIONS ONLY. THE STONE MUST ALSO BE CLEAN, CRUSHED, ANGULAR. FOR EXAMPLE, A SPECIFICATION FOR #4 STONE WOULD STATE: "CLEAN, CRUSHED, ANGULAR NO. 4 (AASHTO M43) STONE".
- STORMTECH COMPACTION REQUIREMENTS ARE MET FOR 'A' LOCATION MATERIALS WHEN PLACED AND COMPACTED IN 6" (150 mm) (MAX) LIFTS USING TWO FULL COVERAGES WITH A VIBRATORY COMPACTOR.
- WHERE INFILTRATION SURFACES MAY BE COMPROMISED BY COMPACTION, FOR STANDARD DESIGN LOAD CONDITIONS, A FLAT SURFACE MAY BE ACHIEVED BY RAKING OR DRAGGING WITHOUT COMPACTION EQUIPMENT. FOR SPECIAL LOAD DESIGNS, CONTACT STORMTECH FOR COMPACTION REQUIREMENTS.
- ONCE LAYER 'C' IS PLACED, ANY SOIL/MATERIAL CAN BE PLACED IN LAYER 'D' UP TO THE FINISHED GRADE. MOST PAVEMENT SUBBASE SOILS CAN BE USED TO REPLACE THE MATERIAL REQUIREMENTS OF LAYER 'C' OR 'D' AT THE SITE DESIGN ENGINEER'S DISCRETION.

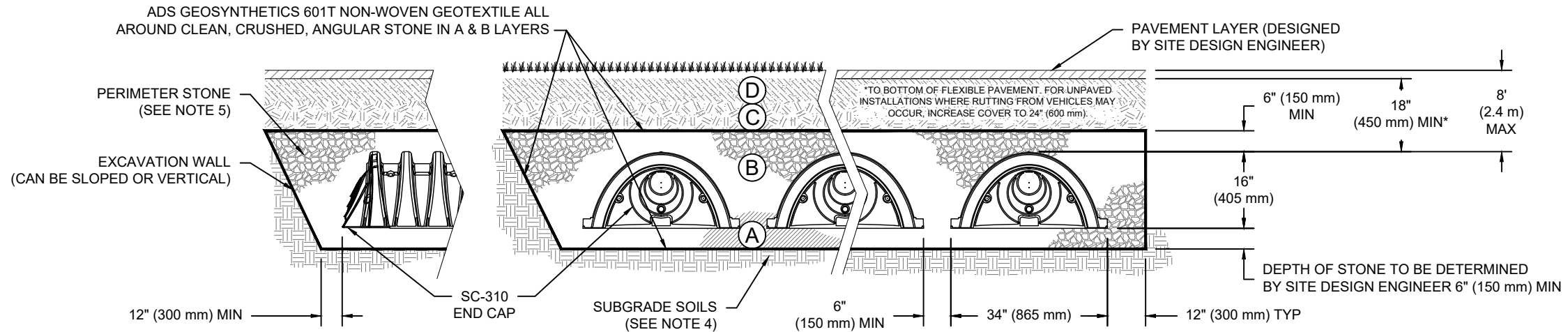

**NOTES:**

- CHAMBERS SHALL MEET THE REQUIREMENTS OF ASTM F2922 (POLETHYLENE) OR ASTM F2418 (POLYPROPYLENE), "STANDARD SPECIFICATION FOR CORRUGATED WALL STORMWATER COLLECTION CHAMBERS".
- SC-310 CHAMBERS SHALL BE DESIGNED IN ACCORDANCE WITH ASTM F2787 "STANDARD PRACTICE FOR STRUCTURAL DESIGN OF THERMOPLASTIC CORRUGATED WALL STORMWATER COLLECTION CHAMBERS".
- THE SITE DESIGN ENGINEER IS RESPONSIBLE FOR ASSESSING THE BEARING RESISTANCE (ALLOWABLE BEARING CAPACITY) OF THE SUBGRADE SOILS AND THE DEPTH OF FOUNDATION STONE WITH CONSIDERATION FOR THE RANGE OF EXPECTED SOIL MOISTURE CONDITIONS.
- PERIMETER STONE MUST BE EXTENDED HORIZONTALLY TO THE EXCAVATION WALL FOR BOTH VERTICAL AND SLOPED EXCAVATION WALLS.
- REQUIREMENTS FOR HANDLING AND INSTALLATION:
  - TO MAINTAIN THE WIDTH OF CHAMBERS DURING SHIPPING AND HANDLING, CHAMBERS SHALL HAVE INTEGRAL, INTERLOCKING STACKING LUGS.
  - TO ENSURE A SECURE JOINT DURING INSTALLATION AND BACKFILL, THE HEIGHT OF THE CHAMBER JOINT SHALL NOT BE LESS THAN 2".
  - TO ENSURE THE INTEGRITY OF THE ARCH SHAPE DURING INSTALLATION, a) THE ARCH STIFFNESS CONSTANT SHALL BE GREATER THAN OR EQUAL TO 400 LBS/FT/%. THE ASC IS DEFINED IN SECTION 6.2.8 OF ASTM F2418. AND b) TO RESIST CHAMBER DEFORMATION DURING INSTALLATION AT ELEVATED TEMPERATURES (ABOVE 73° F / 23° C), CHAMBERS SHALL BE PRODUCED FROM REFLECTIVE GOLD OR YELLOW COLORS.

3850 CAMBRIAN RD FOR  
 PCSWMM  
 OTTAWA, ON, CANADA  
 DATE: \_\_\_\_\_  
 DRAWN: BU  
 PROJECT #: \_\_\_\_\_  
 CHECKED: N/A

DATE	DRW	CHK	DESCRIPTION

**StormTech®**  
 Chamber System  
 888-892-2694 | WWW.STORMTECH.COM

4640 TRUEMAN BLVD  
 HILLIARD, OH 43026  
 1-800-733-7473

THIS DRAWING HAS BEEN PREPARED BASED ON INFORMATION PROVIDED TO ADS UNDER THE DIRECTION OF THE SITE DESIGN ENGINEER OR OTHER PROJECT REPRESENTATIVE. THE SITE DESIGN ENGINEER SHALL REVIEW THIS DRAWING PRIOR TO CONSTRUCTION. IT IS THE ULTIMATE RESPONSIBILITY OF THE SITE DESIGN ENGINEER TO ENSURE THAT THE PRODUCT(S) DEPICTED AND ALL ASSOCIATED DETAILS MEET ALL APPLICABLE LAWS, REGULATIONS, AND PROJECT REQUIREMENTS.



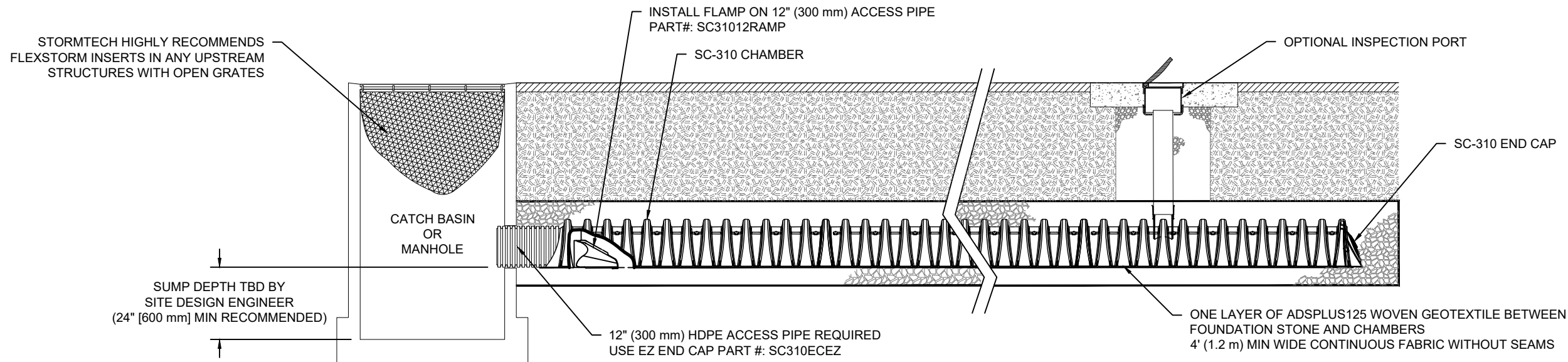

**SC-310 ISOLATOR ROW PLUS DETAIL**  
NTS

**INSPECTION & MAINTENANCE**

- STEP 1) INSPECT ISOLATOR ROW PLUS FOR SEDIMENT
- A. INSPECTION PORTS (IF PRESENT)
    - A.1. REMOVE/OPEN LID ON NYLOPLAST INLINE DRAIN
    - A.2. REMOVE AND CLEAN FLEXSTORM FILTER IF INSTALLED
    - A.3. USING A FLASHLIGHT AND STADIA ROD, MEASURE DEPTH OF SEDIMENT AND RECORD ON MAINTENANCE LOG
    - A.4. LOWER A CAMERA INTO ISOLATOR ROW PLUS FOR VISUAL INSPECTION OF SEDIMENT LEVELS (OPTIONAL)
    - A.5. IF SEDIMENT IS AT, OR ABOVE, 3" (80 mm) PROCEED TO STEP 2. IF NOT, PROCEED TO STEP 3.
  - B. ALL ISOLATOR PLUS ROWS
    - B.1. REMOVE COVER FROM STRUCTURE AT UPSTREAM END OF ISOLATOR ROW PLUS
    - B.2. USING A FLASHLIGHT, INSPECT DOWN THE ISOLATOR ROW PLUS THROUGH OUTLET PIPE
      - i) MIRRORS ON POLES OR CAMERAS MAY BE USED TO AVOID A CONFINED SPACE ENTRY
      - ii) FOLLOW OSHA REGULATIONS FOR CONFINED SPACE ENTRY IF ENTERING MANHOLE
    - B.3. IF SEDIMENT IS AT, OR ABOVE, 3" (80 mm) PROCEED TO STEP 2. IF NOT, PROCEED TO STEP 3.
- STEP 2) CLEAN OUT ISOLATOR ROW PLUS USING THE JETVAC PROCESS
- A. A FIXED CULVERT CLEANING NOZZLE WITH REAR FACING SPREAD OF 45" (1.1 m) OR MORE IS PREFERRED
  - B. APPLY MULTIPLE PASSES OF JETVAC UNTIL BACKFLUSH WATER IS CLEAN
  - C. VACUUM STRUCTURE SUMP AS REQUIRED
- STEP 3) REPLACE ALL COVERS, GRATES, FILTERS, AND LIDS; RECORD OBSERVATIONS AND ACTIONS.
- STEP 4) INSPECT AND CLEAN BASINS AND MANHOLES UPSTREAM OF THE STORMTECH SYSTEM.

**NOTES**

1. INSPECT EVERY 6 MONTHS DURING THE FIRST YEAR OF OPERATION. ADJUST THE INSPECTION INTERVAL BASED ON PREVIOUS OBSERVATIONS OF SEDIMENT ACCUMULATION AND HIGH WATER ELEVATIONS.
2. CONDUCT JETTING AND VACTORING ANNUALLY OR WHEN INSPECTION SHOWS THAT MAINTENANCE IS NECESSARY.

<p>4640 TRUEMAN BLVD HILLIARD, OH 43026 1-800-733-7473</p>	<p align="center"><b>StormTech®</b> Chamber System</p> <p align="center">888-892-2694   WWW.STORMTECH.COM</p>	<p>3850 CAMBRIAN RD FOR PCSWMM OTTAWA, ON, CANADA</p> <p>DATE: _____ DRAWN: BU PROJECT #: _____ CHECKED: N/A</p>
THIS DRAWING HAS BEEN PREPARED BASED ON INFORMATION PROVIDED TO ADS UNDER THE DIRECTION OF THE SITE DESIGN ENGINEER OR OTHER PROJECT REPRESENTATIVE. THE SITE DESIGN ENGINEER SHALL REVIEW THIS DRAWING PRIOR TO CONSTRUCTION. IT IS THE ULTIMATE RESPONSIBILITY OF THE SITE DESIGN ENGINEER TO ENSURE THAT THE PRODUCT(S) DEPICTED AND ALL ASSOCIATED DETAILS MEET ALL APPLICABLE LAWS, REGULATIONS, AND PROJECT REQUIREMENTS.		
SHEET <b>4 OF 5</b>		

# SC-310 TECHNICAL SPECIFICATION

NTS

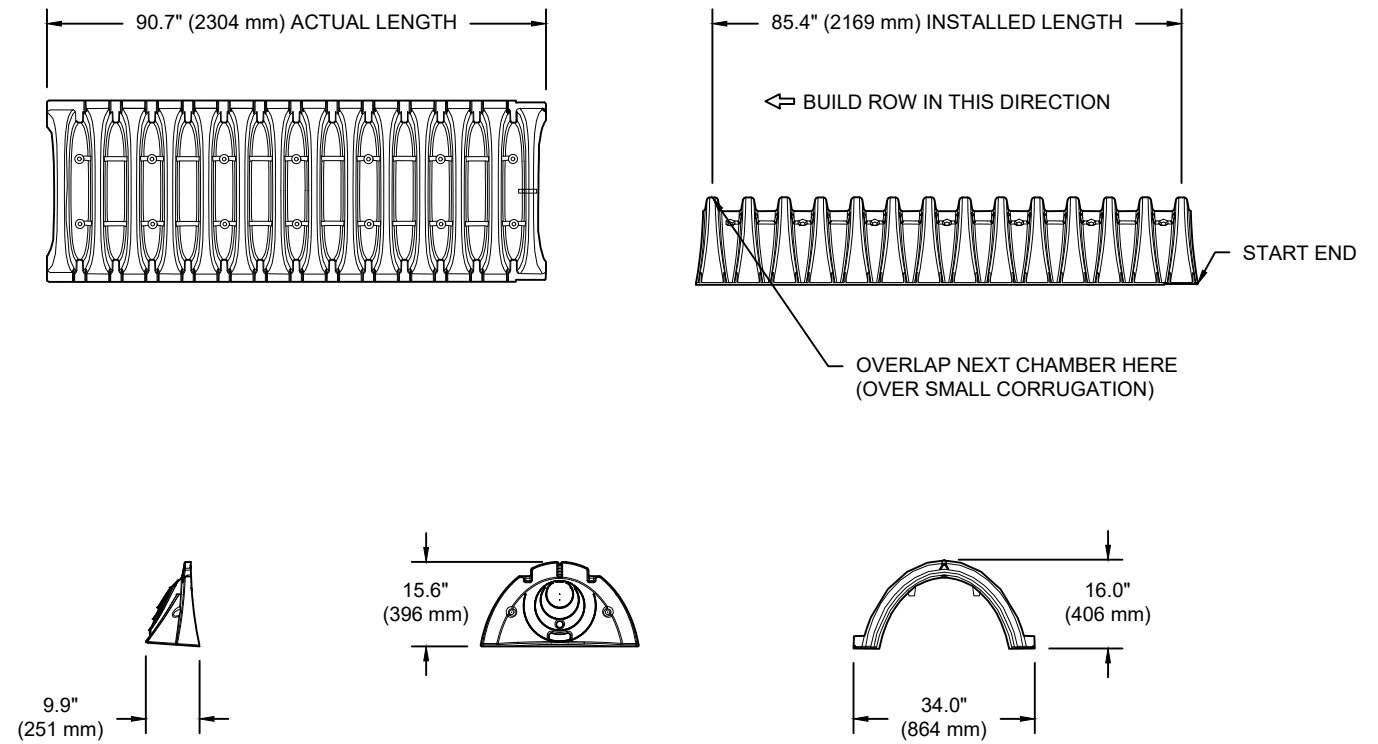

### NOMINAL CHAMBER SPECIFICATIONS

SIZE (W X H X INSTALLED LENGTH)	34.0" X 16.0" X 85.4"	(864 mm X 406 mm X 2169 mm)
CHAMBER STORAGE	14.7 CUBIC FEET	(0.42 m <sup>3</sup> )
MINIMUM INSTALLED STORAGE*	31.0 CUBIC FEET	(0.88 m <sup>3</sup> )
WEIGHT	35.0 lbs.	(16.8 kg)

\*ASSUMES 6" (152 mm) ABOVE, BELOW, AND BETWEEN CHAMBERS

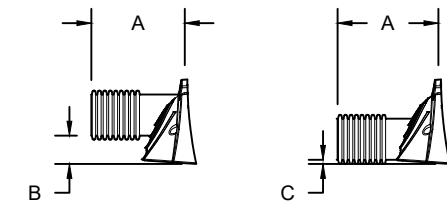

PRE-FAB STUB AT BOTTOM OF END CAP WITH FLAMP END WITH "BR"  
 PRE-FAB STUBS AT BOTTOM OF END CAP FOR PART NUMBERS ENDING WITH "B"  
 PRE-FAB STUBS AT TOP OF END CAP FOR PART NUMBERS ENDING WITH "T"  
 PRE CORED END CAPS END WITH "PC"

PART #	STUB	A	B	C
SC310EPE06T / SC310EPE06TPC	6" (150 mm)	9.6" (244 mm)	5.8" (147 mm)	---
SC310EPE06B / SC310EPE06BPC			---	0.5" (13 mm)
SC310EPE08T / SC310EPE08TPC	8" (200 mm)	11.9" (302 mm)	3.5" (89 mm)	---
SC310EPE08B / SC310EPE08BPC			---	0.6" (15 mm)
SC310EPE10T / SC310EPE10TPC	10" (250 mm)	12.7" (323 mm)	1.4" (36 mm)	---
SC310EPE10B / SC310EPE10BPC			---	0.7" (18 mm)
SC310ECEZ*	12" (300 mm)	13.5" (343 mm)	---	0.9" (23 mm)

ALL STUBS, EXCEPT FOR THE SC310ECEZ ARE PLACED AT BOTTOM OF END CAP SUCH THAT THE OUTSIDE DIAMETER OF THE STUB IS FLUSH WITH THE BOTTOM OF THE END CAP. FOR ADDITIONAL INFORMATION CONTACT STORMTECH AT 1-888-892-2694.

\* FOR THE SC310ECEZ THE 12" (300 mm) STUB LIES BELOW THE BOTTOM OF THE END CAP APPROXIMATELY 0.25" (6 mm). BACKFILL MATERIAL SHOULD BE REMOVED FROM BELOW THE N-12 STUB SO THAT THE FITTING SITS LEVEL.

NOTE: ALL DIMENSIONS ARE NOMINAL

3850 CAMBRIAN RD FOR PCSWMM	DATE:	PROJECT #:
OTTAWA, ON, CANADA	DRAWN: BU	CHECKED: N/A

DATE	DRW	CHK	DESCRIPTION

**StormTech®**  
Chamber System

888-892-2694 | WWW.STORMTECH.COM

4640 TRUEMAN BLVD  
HILLIARD, OH 43026  
1-800-733-7473

**ADS**

THIS DRAWING HAS BEEN PREPARED BASED ON INFORMATION PROVIDED TO ADS UNDER THE DIRECTION OF THE SITE DESIGN ENGINEER OR OTHER PROJECT REPRESENTATIVE. THE SITE DESIGN ENGINEER SHALL REVIEW THIS DRAWING PRIOR TO CONSTRUCTION. IT IS THE ULTIMATE RESPONSIBILITY OF THE SITE DESIGN ENGINEER TO ENSURE THAT THE PRODUCT(S) DEPICTED AND ALL ASSOCIATED DETAILS MEET ALL APPLICABLE LAWS, REGULATIONS, AND PROJECT REQUIREMENTS.

# CONCESSION

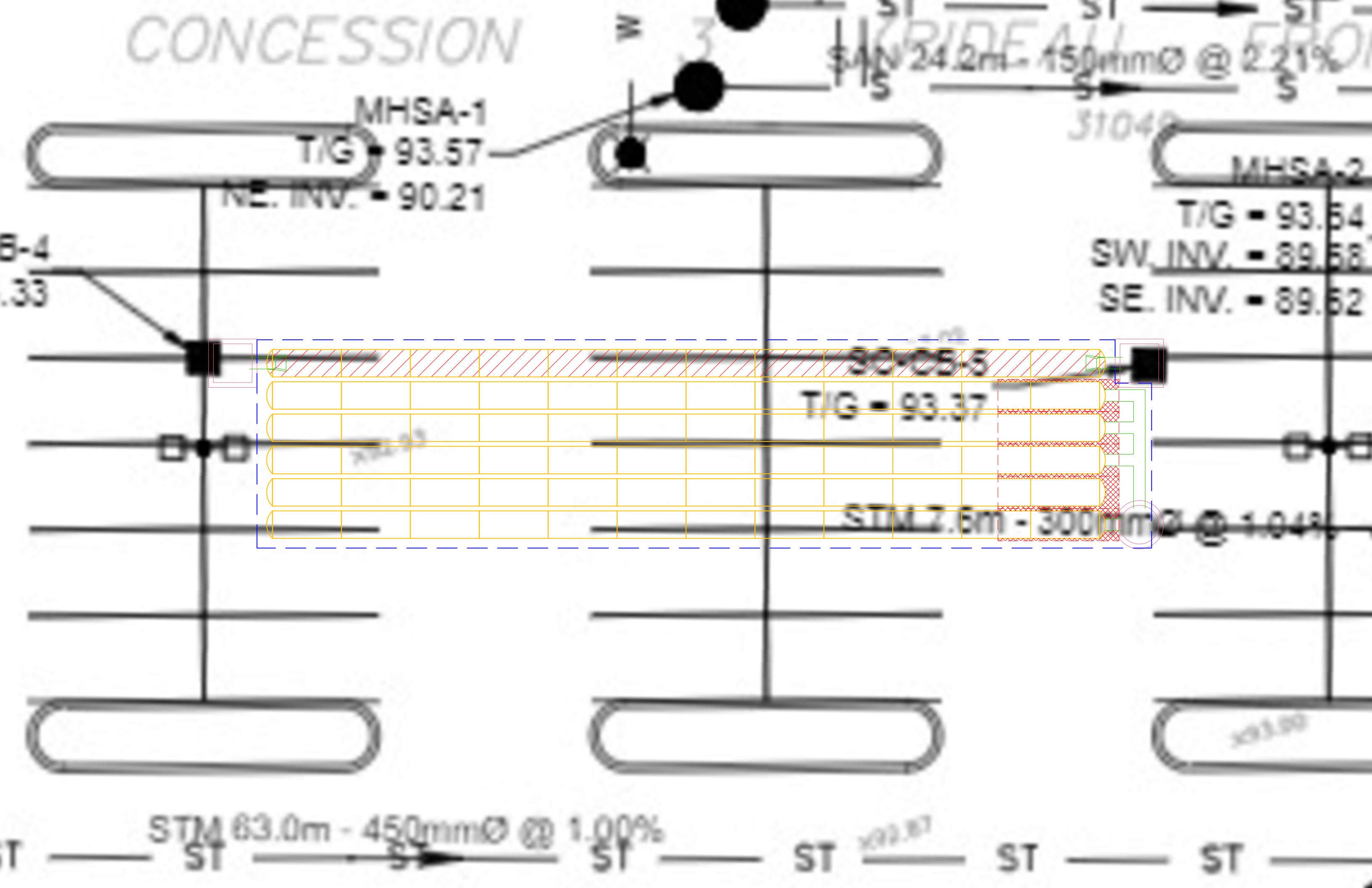

**Appendix F:  
City Correspondence**

# Villeneuve, Benoit [NN-CA]

**From:** Bramah, Bruce <bruce.bramah@ottawa.ca>  
**Sent:** 20 mars 2023 15:00  
**To:** Villeneuve, Benoit [NN-CA]  
**Cc:** Theiner, Mathew [NN-CA]; Harrold, Eric  
**Subject:** [EXTERNAL] RE: 3845 & 3850 Cambrian Rd Commercial Developments - Stormwater Management

Good afternoon Benoit,

Both properties shall comply with the servicing criteria from the final detailed design: Design Brief for the Half Moon Bay West Phase 1, Prepared by DSEL, Project #16-888, dated Sept 5, 2018. The design brief notes a predevelopment C=0.8, Tc=10min. The resulting pre development flows are 348 L/s and 315 L/s for 3845 Cambrian and 3850 Cambrian respectively.

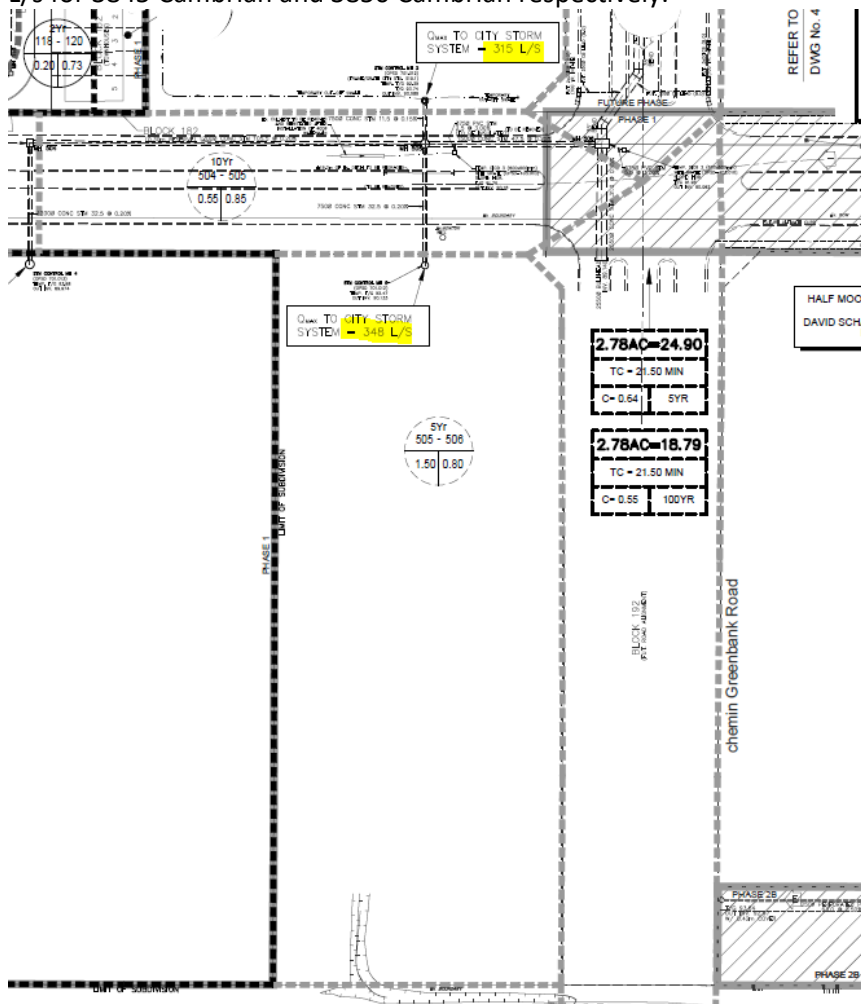

If you have any further questions, please feel free to call me or we can set up a meeting to discuss.

Thank you,

--  
**Bruce Bramah, EIT**  
Project Manager

Planning, Real Estate and Economic Development Department / Direction générale de la planification, des biens immobiliers et du développement économique  
Development Review - South Branch

**From:** Benoit.Villeneuve@parsons.com <Benoit.Villeneuve@parsons.com>  
**Sent:** March 10, 2023 1:24 PM  
**To:** Bramah, Bruce <bruce.bramah@ottawa.ca>; Charie, Kelsey <kelsey.charie@ottawa.ca>; Harrold, Eric <eric.harrold@ottawa.ca>  
**Cc:** Theiner, Mathew <mathew.theiner@parsons.com>; Moore, Sean <Sean.Moore@ottawa.ca>; O'Callaghan, Katie <katie.ocallaghan@ottawa.ca>  
**Subject:** 3845 & 3850 Cambrian Rd Commercial Developments - Stormwater Management

**CAUTION: This email originated from an External Sender. Please do not click links or open attachments unless you recognize the source.**

**ATTENTION : Ce courriel provient d'un expéditeur externe. Ne cliquez sur aucun lien et n'ouvrez pas de pièce jointe, excepté si vous connaissez l'expéditeur.**

Hi,

Parsons is currently providing municipal engineering services for both commercial development located at 3845 Cambrian Rd and 3850 Cambrian Rd. These two sites are across from each other on Cambrian Rd and are serviced by the same storm sewer previously installed in 2019 for the future re-aligned Greenbank Rd. (see image below)

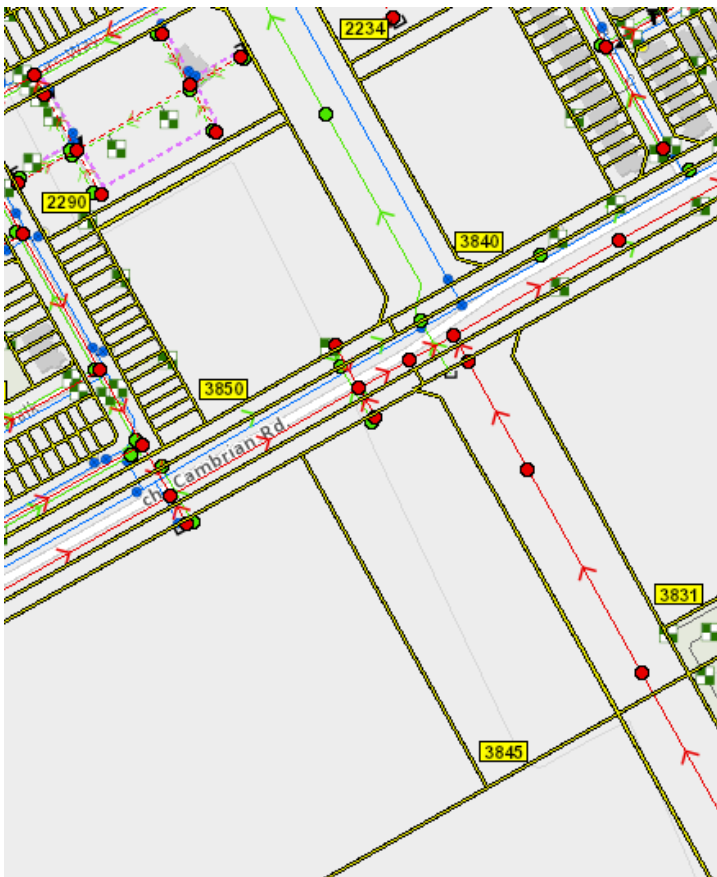

According to pre-consultation meeting notes for both projects (see attached), the allowable release rate for each site is determined using two different methods.

For 3850 Cambrian Rd the allowable release rate is calculated using the following parameters:

- Allowable runoff coefficient = lesser of existing pre-development to a maximum of 0.5 (in our case C=0.2 as this is a vacant land)
- Time of concentration = pre-development, maximum 10 min
- Allowable flowrate using  $T_c=10\text{min}$ ,  $C=0.2$  and an area of 1.4 ha,  $Q_{\text{allowable}} = 81.1 \text{ L/s}$

For 3845 Cambrian Rd the allowable release rate is calculated using the following parameters:

- Allowable runoff coefficient = 0.8
- Time of concentration = 10 min
- Site area = 1.5 ha
- Allowable flowrate = 348 L/s

Furthermore, as these two properties are part of the Half Moon Bay West Subdivision, these two sites were taken into account in the design of the new storm sewer along future Greenbank Rd and the new Clarke Pond. Based on the *Functional Servicing and Stormwater Management Report for the Half Moon Bay West Subdivision, dated March 8, 2019 by Mattamy Homes and DSEL*, the storm sewer was designed using runoff coefficient of 0.8 for both properties and a time of concentration of 29.62 min and 31.23 min for 3845 Cambrian and 3850 Cambrian respectively. Appendix D of this report showing the storm drainage plan and storm design sheets is attached for your reference.

Using the time of concentration mentioned above and runoff coefficient of 0.8, the allowable release rate for 3845 Cambrian is 181.5 L/s and 163.4 L/s for 3850 Cambrian.

We would like you to discuss and let us know which method of calculations should be used for both of these commercial developments. We could also arrange a meeting in the middle of next week to discuss.

If you have any questions please let us know.

Thank you,

**Benoit Villeneuve, EIT**

Junior Designer

100-1223 Michael St North, Ottawa, ON K1J 7T2

[benoit.villeneuve@parsons.com](mailto:benoit.villeneuve@parsons.com)

P : +1 613.691.1596

[Parsons \[can01.safelinks.protection.outlook.com\]](#) / [LinkedIn \[can01.safelinks.protection.outlook.com\]](#) / [Twitter \[can01.safelinks.protection.outlook.com\]](#)

[\[can01.safelinks.protection.outlook.com\]](#) / [Facebook \[can01.safelinks.protection.outlook.com\]](#) / [Instagram \[can01.safelinks.protection.outlook.com\]](#)

[\[can01.safelinks.protection.outlook.com\]](#)



'NOTICE: This email message and all attachments transmitted with it may contain privileged and confidential information, and information that is protected by, and proprietary to, Parsons Corporation, and is intended solely for the use of the addressee for the specific purpose set forth in this communication. If the reader of this message is not the intended recipient, you are hereby notified that any reading, dissemination, distribution, copying, or other use of this message or its attachments is strictly prohibited, and you should delete this message and all copies and backups thereof. The recipient may not further distribute or use any of the information contained herein without the express written authorization of the sender. If you have received this message in error, or if you have any questions regarding the use of the proprietary information contained therein, please contact the sender of this message immediately, and the sender will provide you with further instructions.'

This e-mail originates from the City of Ottawa e-mail system. Any distribution, use or copying of this e-mail or the information it contains by other than the intended recipient(s) is unauthorized. Thank you.

Le présent courriel a été expédié par le système de courriels de la Ville d'Ottawa. Toute distribution, utilisation ou reproduction du courriel ou des renseignements qui s'y trouvent par une personne autre que son destinataire prévu est interdite. Je vous remercie de votre collaboration.



## Boundary Conditions 3850 Cambrian Rd

### Provided Information

Scenario	Demand	
	L/min	L/s
Average Daily Demand	7	0.11
Maximum Daily Demand	10	0.17
Peak Hour	19	0.31
Fire Flow Demand #1	6,000	100.00

### Location



### Results

#### Existing Conditions (Pressure Zone 3SW)

Connection 1 – Cambrian Rd.

Demand Scenario	Head (m)	Pressure <sup>1</sup> (psi)
Maximum HGL	156.5	89.9
Peak Hour	142.6	70.1
Max Day plus Fire Flow	138.9	64.9

<sup>1</sup> Ground Elevation = 93.3 m

#### Future Conditions (Pressure Zone SUC)

Connection 1 – Cambrian Rd.

Demand Scenario	Head (m)	Pressure <sup>1</sup> (psi)
Maximum HGL	146.8	76.0
Peak Hour	142.8	70.4
Max Day plus Fire Flow	143.8	71.8

<sup>1</sup> Ground Elevation = 93.3 m

### **Notes**

1. As per the Ontario Building Code in areas that may be occupied, the static pressure at any fixture shall not exceed 552 kPa (80 psi.) Pressure control measures to be considered are as follows, in order of preference:
  - a. If possible, systems to be designed to residual pressures of 345 to 552 kPa (50 to 80 psi) in all occupied areas outside of the public right-of-way without special pressure control equipment.
  - b. Pressure reducing valves to be installed immediately downstream of the isolation valve in the home/ building, located downstream of the meter so it is owner maintained.

### **Disclaimer**

*The boundary condition information is based on current operation of the city water distribution system. The computer model simulation is based on the best information available at the time. The operation of the water distribution system can change on a regular basis, resulting in a variation in boundary conditions. The physical properties of watermains deteriorate over time, as such must be assumed in the absence of actual field test data. The variation in physical watermain properties can therefore alter the results of the computer model simulation. Fire Flow analysis is a reflection of available flow in the watermain; there may be additional restrictions that occur between the watermain and the hydrant that the model cannot take into account.*

**Appendix G:  
Zurn Control-Flo Roof Drains Specifications**



SPECIFICATION DRAINAGE

# Control-Flo Roof Drainage System



[www.zurn.com](http://www.zurn.com)



# Control-Flo...Today's Successful Answer to More

## THE ZURN "CONTROL-FLO CONCEPT"

Originally, Zurn introduced the scientifically-advanced "Control-Flo" drainage principle for dead-level roofs. Today, after thousands of successful applications in modern, large dead-level roof areas, Zurn engineers have adapted the comprehensive "Control-Flo" data to **sloped roof** areas.

## WHAT IS "CONTROL-FLO"?

It is an advanced method of removing rain water off dead-level or sloped roofs. As contrasted with conventional drainage practices, which attempt to drain off storm water as quickly as it falls on the roof's surface, "Control-Flo" drains the roof at a controlled rate. Excess water accumulates on the roof under controlled conditions...then drains off at a lower rate after a storm abates.

## CUTS DRAINAGE COSTS

Fewer roof drains, smaller diameter piping, smaller sewer sizes, and lower installation costs are possible with a "Control-Flo" drainage system because roof areas are utilized as temporary storage reservoirs.

## REDUCES PROBABILITY OF STORM DAMAGE

Lightens load on combination sewers by reducing rate of water drained from roof tops during severe storms thereby reducing probability of flooded sewers, and consequent backflow into basements and other low areas.

## THANKS TO EXCLUSIVE ZURN "AQUA-WEIR" ACTION

Key to successful "Control-Flo" drainage is a unique scientifically-designed weir containing accurately calibrated notches with sides formed by parabolic curves which provide flow rates directly proportional to the head. Shape and size of notches are based on predetermined flow rates, and all factors involved in roof drainage to assure permanent regulation of drainage flow rates for specific geographic locations and rainfall intensities.

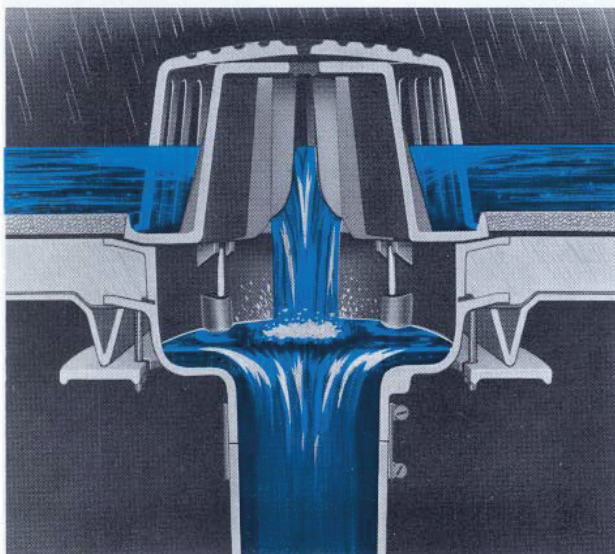

## DEFINITION

### DEAD LEVEL ROOFS

#### DIAGRAM "A"

A dead-level roof for purposes of applying the Zurn "Control-Flo" drainage principle is one which has been designed for zero slope across its entire surface. Measurements shown are for maximum distances.

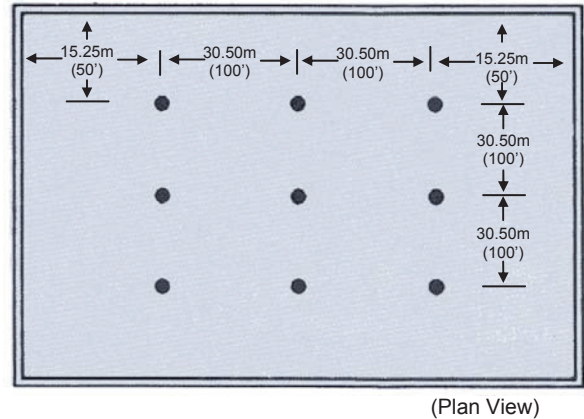

(Plan View)

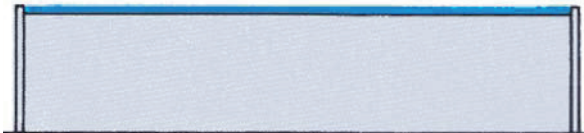

(Section View)

### SLOPED ROOFS

#### DIAGRAM "B"

A sloped roof is one designed commonly with a shallow slope. The Zurn "Control-Flo" drainage system can be applied to any slope which results in a total rise up to 152mm (6"). The total rise of a roof as calculated for "Control-Flo" application is defined as the vertical increase in height in inches, from the low point or valley of a sloping roof (A) to the top of the sloping section (B). (Example: a roof that slopes 3mm (1/8") per foot having a 7.25m (24') span would have a rise of 7.25m x 3mm or 76mm (24' x 1/8" or 3"). Measurements shown are for maximum distances.

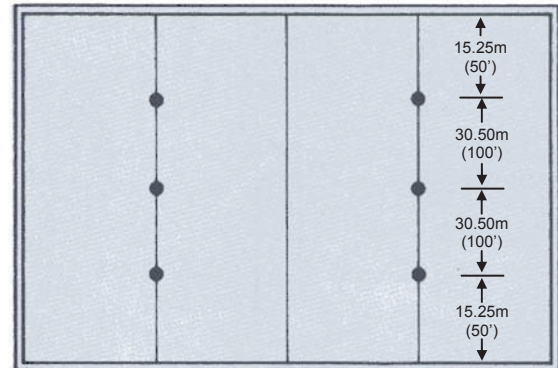

(Plan View)

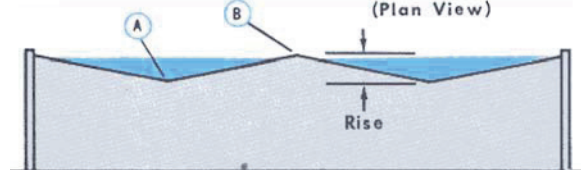

(Section View)

# Economical Roof Drainage Installations

## SPECIFICATION DATA

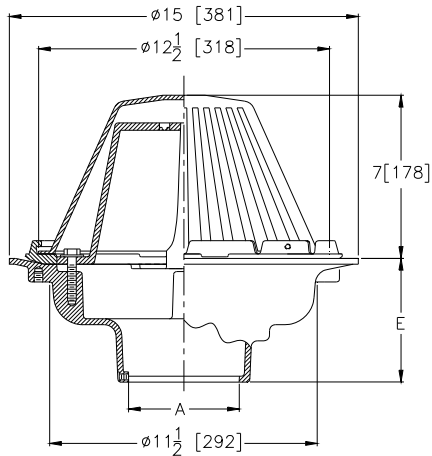

**ENGINEERING SPECIFICATION:** ZURN Z-105 "Control-Flo" roof drain for dead-level or sloped roof construction, Dura-Coated cast iron body. "Control-Flo" weir shall be linear functioning with integral membrane flashing clamp/gravel guard and Poly-Dome. All data shall be verified proportional to flow rates.

## ROOF DESIGN RECOMMENDATIONS

Basic roofing design should incorporate protection that will prevent roof overloading by installing adequate overflow scuppers in parapet walls.

## GENERAL INFORMATION

The "Control-Flo" roof drainage data is tabulated for four areas (232.25m<sup>2</sup> (2500 sq. ft.), 464.502m<sup>2</sup> (5000 sq. ft.), 696.75m<sup>2</sup> (7500 sq. ft.), 929m<sup>2</sup> (10,000 sq. ft.) notch areas ratings) for each locality. For each notch area rating the maximum discharge in L.P.M. (G.P.M.) - draindown in hours, and maximum water depth at the drain in inches for a dead level roof — 51mm (2 inch) rise — 102mm (4 inch) rise and 152mm (6 inch) rise—are tabulated. The rise is the total change in elevation from the valley to the peak. Values for areas, rise or combination thereof other than those listed, can be arrived at by extrapolation. All data listed is based on the fifty-year return frequency storm. In other words the maximum conditions as listed will occur on the average of once every fifty years.

**NOTE:** The tabulated "Control-Flo" data enables the individual engineer to select his own design limiting condition. The limiting condition can be draindown time, roof load factor, or maximum water depth at the drain. If draindown time is the limiting factor because of possible freezing conditions, it must be recognized that the maximum time listed will occur on the average of once every 50 years and would most likely be during a heavy summer thunder storm. Average winter draindown times would be much shorter in duration than those listed.

## GENERAL RECOMMENDATIONS

On sloping roofs, we recommend a design depth referred to as an equivalent depth. An equivalent depth is the depth of water attained at the drains that results in the same roof stresses as those realized on a dead-level roof. In all cases this equivalent depth is almost equal to that attained by using the same notch area rating for the different rises to 152mm (6"). With the same depth of water at the drain the roof stresses will decrease with increasing total rise. Therefore, it would be possible to have a depth in excess of 152mm (6") at the drain on a sloping roof without exceeding stresses normally encountered in a 152mm (6") depth on a dead-level roof. However, it is recommended that scuppers be placed to limit the maximum water depth on any roof to 152mm (6") to prevent the overflow of the weirs on the drains and consequent overloading of drain piping. In the few cases where the data shows a flow rate in excess of 136 L.P.M. (30 G.P.M.) if all drains and drain lines are sized according to recommendations, and the one storm in fifty years occurs, the only consequence will be a brief flow through the scuppers or over-flow drains.

**NOTE:** An equivalent depth is that depth of water attained at the drains at the lowest line or valley of the roof with all other conditions such as notch area and rainfall intensity being equal. For Toronto, Ontario a notch area rating of 464.50m<sup>2</sup> (5,000 sq. ft.) results in a 74mm (2.9 inch) depth on a dead level roof for a 50-year storm. For the same notch area and conditions, equivalent depths for a 51mm (2"), 102mm (4") and 152mm (6") rise respectively on a sloped roof would be 86mm (3.4"), 104mm (4.1") and 124mm (4.9"). Roof stresses will be approximately equal in all cases.



## Control-Flo Drain Selection Is Quick and Easy...

The exclusive Zurn "Selecta-Drain" Chart (pages 8—11) tabulates selection data for 34 localities in Canada. Proper use of this chart constitutes your best assurance of sure, safe, economical application of Zurn "Control-Flo" systems for your specific geographical area. If the "Selecta-Drain Chart does not cover your specific design criteria, contact Zurn Industries Limited, Mississauga, Ontario, for additional data for your locality. Listed below is additional information pertinent to proper engineering of the "Control-Flo" system.

### ROOF USED AS TEMPORARY RETENTION

The key to economical "Control-Flo" is the utilization of large roof areas to temporarily store the maximum amount of water without overloading average roofs or creating excessive draindown time during periods of heavy rainfall. The data shown in the "Selecta-Drain" Chart enables the engineer to select notch area ratings from 232.25 m<sup>2</sup> (2,500 ft.<sup>2</sup>) to 929m<sup>2</sup> (10,000 ft.<sup>2</sup>) and to accurately predict all other design factors such as maximum roof load, L.P.M. (G.P.M.) discharge, draindown time and water depth at the drain. Obviously, as design factors permit the notch area rating to increase the resulting money saved in being able to use small leaders and drain lines will also increase.

### ROOF LOADING AND RUN-OFF RATES

The four values listed in the "Selecta-Drain" Chart for notch area ratings for different localities will normally span the range of good design. If areas per notch below 232.25m<sup>2</sup> (2,500 ft.<sup>2</sup>) are used considerable economy of the "Control-Flo" concept is being lost. The area per notch is limited to 929m<sup>2</sup> (10,000 ft.<sup>2</sup>) to keep the drain-down time within reasonable limits. Extensive studies show that stresses due to water load on a sloping roof for any fixed set of conditions are very nearly the same as those on a dead-level roof. A sloping roof tends to concentrate more water in the valleys and increase the water depth at this point. The greater depth around the drain leads to a faster run-off rate, particularly a faster early run-off rate. As a result, the total volume of water stored on the roof is less, and the total load on the sloping roof is less. By using the same area on the sloping roof as on the dead-level roof the increase in roof stresses due to increased water depth in the valleys is offset by the decrease in the total load due to less water stored. The net result of the maximum roof stress is approximately the same for any single span rise and fixed set of conditions. A fixed set of conditions, would be the same notch area, the same frequency store, and the same locality.

**SPECIAL CONSIDERATIONS FOR STRUCTURAL SAFETY:** Normal practice of roof design is based on 18kg (40 lbs.) per 929 cm<sup>2</sup> ( sq ft.). (Subject to local codes and by-laws.) Thus it is extremely important that design is in accordance with normal load factors so deflection will be slight enough in any bay to prevent progressive deflection which could cause water depths to load the roof beyond its design limits.

### ADDITIONAL NOTCH RATINGS

The "Selecta-Drain" Chart along with Tables I and II enables the engineer to select "Control-Flo" Drains and drain pipe sizes for most Canadian applications. These calculations are computed for a proportional flow weir that is sized to give a flow of 23 L.P.M. (5 G.P.M.) per inch of head. The 23 L.P.M. (5 G.P.M.) per inch of head notch opening is selected as the bases of design as it offers the most economical installation as applied to actual rainfall experienced in Canada.

Should you require design criteria for locations outside of Canada or for special project applications please contact Zurn Industries Limited, Mississauga, Ontario.

### LEADER AND DRAIN PIPE SIZING

Since all data in the "Selecta-Drain" Chart is based on the 50-year-storm it is possible to exceed the water depth listed in these charts if a 100-year or 1000-year storm would occur. Therefore, for good design it is recommended that scuppers or other methods be used to limit water depth to the design depth and tables I and II be used to size the leaders and drain pipes. If the roof is capable of supporting more water than the design depth it is permissible to locate the scuppers or other overflow means at a height that will allow a greater water depth on the roof. However, in this case the leader and drain pipes should be sized to handle the higher flow rates possible based on a flow rate of 23 L.P.M. (5 G.P.M.) per inch of depth at the drain.

### PROPER DRAIN LOCATION

The following good design practice is recommended for selecting the proper number of "Control-Flo" drains for a given area. **On dead-level roofs**, drains should be located no further than 15.25m (50 feet) from edge of roof and no further than 30.50m (100 feet) between drains. See diagram "A" page 2. **On sloping roofs**, drains should be located in the valleys at a distance no greater than 15.25m (50 feet) from each end of the valleys and no further than 30.50m (100 feet) between drains. See diagram "B" page 2. Compliance with these recommendations will assure good run off regardless of wind direction.

# Saves Specification Time, Assures Proper Application



## QUICK, EASY SELECTION

Using the "Selecta-Drain" Chart (pages 9—13) in combination with the steps and examples appearing below, should save you countless hours in engineering specification time. This vast compilation of data is related to the proper selection of drains for 34 cities. All cities in alphabetical order by province. If a specific city does not appear in the tabulation, chooses the city nearest your area and select the proper drain using these factors.

## 3 EASY STEPS...

### AND 3 TYPICAL EXAMPLES FOR APPLICATION OF SURE, SCIENTIFIC CONTROL OF DRAINAGE FROM DEAD-LEVEL AND SLOPING ROOFS WITH THE ZURN CONCEPT.

**NOTE:** Where roof area to be drained is adjacent to one or more vertical walls projecting above the roof, then a percentage of the of the wall(s) must be added to the roof area in determining total roof area to be drained.

TORONTO, ONTARIO	DEAD-LEVEL ROOF	102mm (4 INCH) SLOPE	152mm (6 INCH) SLOPE
<b>1</b> Determine total roof area or individual areas when roof is divided by expansion joints or peaks in the case of sloping roof.	Roof Area: 56.52m x 152.40m = 8918.40m <sup>2</sup> (192ft x 500ft = 96,000 sq. ft.) (See Z105 layout bottom of this page.)	3 Individual Roof Areas: 19.50m x 152.40m = 2972.80m <sup>2</sup> (64ft x 500ft = 32,000 sq. ft.) Valleys 152.40m (500ft) long 3 x 2972.80 = 8918.40m <sup>2</sup> (3 x 32,000 = 96,000 sq. ft.)	2 Individual Roof Areas: 29.87m x 152.40m = 4552m <sup>2</sup> (98ft x 500ft = 49,000 sq. ft.) Valleys 152.40m (500ft) long 2 x 4552 = 9104m <sup>2</sup> (2 x 49,000 = 98,000 sq. ft.)
<b>2</b> Divide roof area or individual areas by Zurn Notch Area Rating selected to obtain the total number of notches required.	Zurn Notch Area Rating selected for Toronto = 464.50m <sup>2</sup> (5,000 sq. ft.) from "Selecta-Drain Chart, page 11. Total Roof Area = 8918.40m <sup>2</sup> (96,000 sq. ft.) Entire roof. 464.50m <sup>2</sup> (5,000 sq. ft.) notch area = 19.2 notches—USE 20.	Zurn Notch Area Rating selected for Toronto = 464.50m <sup>2</sup> (5,000 sq. ft.) from "Selecta-Drain Chart, page 11. Total Roof Area = 2972.80m <sup>2</sup> (32,000 sq. ft.) Each area. 464.50m <sup>2</sup> (5,000 sq. ft.) notch area = 6.4 notches—USE 7 PER AREA.	Zurn Notch Area Rating selected for Toronto = 464.50m <sup>2</sup> (5,000 sq. ft.) from "Selecta-Drain Chart, page 11. Total Roof Area = 4552m <sup>2</sup> (49,000 sq. ft.) Each area. 464.50m <sup>2</sup> (5,000 sq. ft.) notch area = 9.8 notches—USE 10 PER AREA.
<b>3</b> Determine total number of drains required by not exceeding maximum spacing dimensions in the preceding instructions. See Diagrams "A" or "B", page 2. Divide total number of notches required to determine the number of notches per drain. Note maximum water depth at drain and use this dimension to determine scupper height. Maximum scupper height to be used is 152mm (6"). Use this flow rate to size leaders and drain lines.	*10 drains required. All drains must have two notches each for a total of 20 notches. Flow rate is 66 L.P.M. (14.5 G.P.M.) per notch. Size leaders for 2 notch weirs for a flow rate of 66 L.P.M. (14.5 G.P.M.) 50 mm (two inch) pipe size leaders required. Maximum water depth and scupper height is 74mm (2.9"). Requires 19 hours drain-down time maximum. For drain, vertical and horizontal pipe sizing data see Tables I and II on page 6 and 7.	**5 drains per area required located in the valleys 15.25m (50ft.) from each end with 3 in the middle at 30.50m (100ft.) spacings. Two drains on ends with two notches—3 drains in middle on notch each for a total of 7 notches. Maximum flow rate 93 L.P.M. (20.5 G.P.M.) per notch. Leader size 50mm (2") for single notch weirs—75mm (3") notch weirs. Maximum water depth and scupper height is 104mm (4.1"). Requires 11 hours draindown time maximum. For drain, vertical and horizontal pipe sizing data see Tables I and II on page 6 and 7.	**5 drains per area required located in the valleys 15.25m (50ft.) from each end with 3 in the middle at 30.50m (100ft.) spacing in the middle. 10 notches are required therefore all drains must have two notches. Flow rate is 111 L.P.M. (24.5 G.P.M.) per notch. Size all leaders for 2 notch weirs. 75mm (3") pipe size required. Maximum water depth and scupper height is 124mm (4.9"). Requires 9 hours draindown time maximum. For drain, vertical and horizontal pipe sizing data see Tables I and II on page 6 and 7.

\*See Diagram "A" page 2 for recommended drain placement.  
\*\*See Diagram "B" page 2 for recommended drain placement.

### DEAD LEVEL ROOF 6mm (1/4") PER FT. SLOPE STORM DRAIN

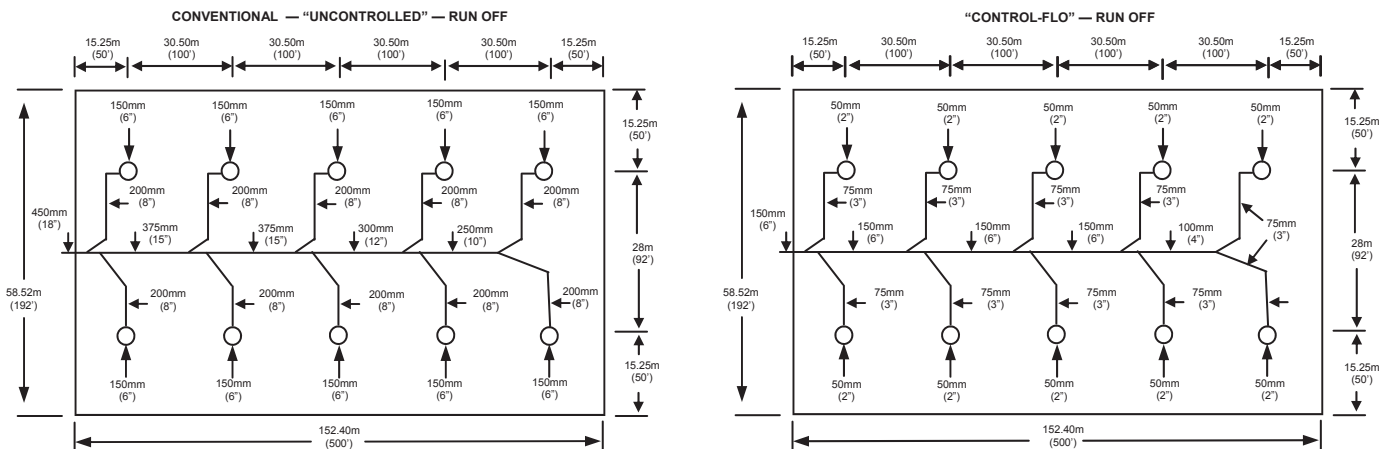





# Select The Proper Vertical Drain Leaders

## ROOF DRAINAGE DATA

The flow rate for any design condition can be easily read from the data contained on the following pages; the tabulations shown below (and on the opposite page) can be used to simplify selection of drain line sizes.

**TABLE 1 - SUGGESTED RELATION OF DRAIN OUTLET AND VERTICAL LEADER SIZE TO ZURN CONTROL-FLO ROOF DRAINS (BASED ON NATIONAL PLUMBING CODE ASA -A40.8 DATA ON VERTICAL LEADERS).**

No. of Notches in Drain	Max. Flow per Notch in L.P.M. (G.P.M.)		
	Pipe Size		
	50mm (2")	75mm (3")	100mm (4")
1	136* (30*)	—	—
2	68 (15)	136* (30*)	—
3	45 (10)	136* (30*)	—
4	—	105 (23)	136* (30*)
5	—	82 (18)	136* (30*)
6	—	68 (15)	136* (30*)

\*Maximum flow obtainable from 1 notch with 152mm (6") water depth at drain.

Table 1 should be used to select vertical drain leaders which at the same time establishes the drain outlet size. This table illustrates the minimum flow per notch in L.P.M. (G.P.M.) Since the Z-105 drain is available with a minimum of one and a maximum of six notches, calculations have already been made and are listed in this table for any quantity of weir notch openings established in your design. It was determined ten drains with two notches each weir would be required in the Dead-Level Roof example on page 5. A 66 L.P.M. (14.5 G.P.M.) discharge per notch flow rate was also established.

Once this design criteria has been determined it will be the key to the proper selection of all drain outlet sizes, vertical and horizontal storm drain sizes in Table I and II. Enter the column "Number of Notches in Drain", Table I, read down the column to the figure 2 which indicates two notches in weir, then read across until you reach a figure equal to or closest figure in excess of 66 L.P.M. (14.5 G.P.M.) You will find fifteen in the column under 50mm (2") which represents the pipe size. Therefore all drain outlets and vertical leaders are 50mm (2") size.

Let us digress for a moment assuming a specific structure requires a total of six drains each containing a weir with a different number of notches. One with 1, one with 2, etc. Table 1 discloses the pipe size for one notch is 50mm (2"), two notch is 50mm (2"), three notch is 75mm (3"), four notch is 75mm (3"), five notch is 75mm (3") and six notch is 75mm (3") as they all equal or closely exceed the 66 L.P.M. (14.5 G.P.M.) design.

NOTE: Although pipe size calculations should be based on accumulated flow rate, local by-laws should be referred to for minimum pipe size requirements and roof drain spacing.

TABLE II should be used to select horizontal storm drain piping. Use the same flow rate 66 L.P.M. (14.5 G.P.M.) used to establish the vertical leaders to size the storm drainage system and main storm drain. Let us assume the ten drains each with two notch weirs were actually on the roof in two separate lines of five drains each and joined at a common point before leaving the building. Since Table II includes 3mm (1/8"), 6mm (1/4") and 13mm (1/2") per foot slope, let us use 6mm (1/4") as our basis for selection which will take us to the centre section. Starting with the first of five drains we enter the extreme left column in Table II and read down to the figure 2 since this drain has two notches in weir, read across horizontally and the size of first section of horizontal storm drain is 75mm (3") between 1st and 2nd drain, return to left hand column proceed reading down until you reach figure 4 then read across horizontally and the pipe size will be 100mm (4") between 2nd and 3rd drain, 100mm (4") between 3rd and 4th and 125mm (5") (if available) between 4th and 5th. If not available use 150mm (6"). (You may be tempted to use 100mm (4") since the capacity is close. We recommend you go to the larger size.) Pipe size leaving 5th drain would be 150mm (6"). The same sizing would hold true for the second line of five drains. Since both columns of five drains each are being joined together before leaving the building there will be total of twenty notches discharging into the main building storm sewer. Enter left hand column Table II, read down until you reach the figure twenty, then read across horizontally to the 6mm (1/4") per 305mm (1') slope column and you will see a 150mm (6") storm drain will handle the job adequately. The same procedure should be followed for sloped roof installations. The above method of sizing was done to better acquaint you with Table II and its use. The more economical and practical way of laying out and installing this same job is illustrated in the control-flo layout shown on bottom of page 5.

NOTE: Although pipe size calculations should be based on accumulated flow rates, local by-laws should be referred to for minimum pipe size requirements and roof drain spacing.

# Select Proper Horizontal Storm Drain Piping



**Table II — SUGGESTED RELATION OF HORIZONTAL STORM DRAIN SIZE TO ZURN CONTROL-FLO ROOF DRAINAGE**

Total No. of Notches Discharging to Storm Drain	MAX. FLOW PER NOTCH IN L.P.M. (G.P.M.)								MAX. FLOW PER NOTCH IN L.P.M. (G.P.M.)								MAX. FLOW PER NOTCH IN L.P.M. (G.P.M.)							
	Storm Drain Size 3mm (1/8") per 305mm (1') Slope								Storm Drain Size 6mm (1/4") per 305mm (1') Slope								Storm Drain Size 13mm (1/2") per 305mm (1') Slope							
	75 (3")	100 (4")	125 (5")	150 (6")	200 (8")	250 (10")	300 (12")	375 (15")	75 (3")	100 (4")	125 (5")	150 (6")	200 (8")	250 (10")	300 (12")	75 (3")	100 (4")	125 (5")	150 (6")	200 (8")	250 (10")	300 (12")		
1	136* (30*)	—	—	—	—	—	—	136* (30*)	—	—	—	—	—	—	136* (30*)	—	—	—	—	—	—	—		
2	77 (17)	136* (30*)	—	—	—	—	—	109 (24)	136* (30*)	—	—	—	—	—	136* (30*)	—	—	—	—	—	—	—		
3	50 (11)	118 (26)	136* (30*)	—	—	—	—	73 (16)	136* (30*)	—	—	—	—	—	100 (22)	136* (30*)	—	—	—	—	—	—		
4	36 (8)	86 (19)	136* (30*)	—	—	—	—	55 (12)	127 (28)	136* (30*)	—	—	—	—	77 (17)	136* (30*)	—	—	—	—	—	—		
5	—	65 (15)	127* (28*)	136* (30*)	—	—	—	—	100 (22)	136* (30*)	—	—	—	—	59 (13)	136* (30*)	—	—	—	—	—	—		
6	—	59 (13)	105 (23)	136* (30*)	—	—	—	—	82 (18)	136* (30*)	—	—	—	—	50 (11)	118 (26)	136* (30*)	—	—	—	—	—		
7	—	50 (11)	91 (20)	136* (30*)	—	—	—	—	73 (16)	127 (28)	136* (30*)	—	—	—	—	100 (22)	136* (30*)	—	—	—	—	—		
8	—	—	77 (17)	127 (28)	136* (30*)	—	—	—	64 (14)	114 (25)	136* (30*)	—	—	—	—	86 (19)	136* (30*)	—	—	—	—	—		
9	—	—	68 (15)	114 (25)	136* (30*)	—	—	—	55 (12)	100 (22)	136* (30*)	—	—	—	—	77 (17)	136* (30*)	—	—	—	—	—		
10	—	—	64 (14)	100 (22)	136* (30*)	—	—	—	—	91 (20)	136* (30*)	—	—	—	—	68 (15)	123 (27)	136* (30*)	—	—	—	—		
11	—	—	55 (12)	91 (20)	136* (30*)	—	—	—	—	82 (18)	132 (29)	136* (30*)	—	—	—	64 (14)	114 (25)	136* (30*)	—	—	—	—		
12	—	—	—	82 (18)	136* (30*)	—	—	—	—	73 (16)	118 (26)	136* (30*)	—	—	—	59 (13)	105 (23)	136* (30*)	—	—	—	—		
13	—	—	—	77 (17)	136* (30*)	—	—	—	—	68 (15)	109 (24)	136* (30*)	—	—	—	55 (12)	95 (21)	136* (30*)	—	—	—	—		
14	—	—	—	73 (16)	136* (30*)	—	—	—	—	64 (14)	100 (22)	136* (30*)	—	—	—	—	86 (19)	136* (30*)	—	—	—	—		
15	—	—	—	68 (15)	136* (30*)	—	—	—	—	59 (13)	95 (21)	136* (30*)	—	—	—	—	82 (18)	132 (29)	136* (30*)	—	—	—		
16	—	—	—	64 (14)	136* (30*)	—	—	—	—	91 (20)	136* (30*)	—	—	—	—	77 (17)	123 (27)	136* (30*)	—	—	—	—		
17	—	—	—	59 (13)	127 (28)	136* (30*)	—	—	—	—	82 (18)	136* (30*)	—	—	—	—	73 (16)	118 (26)	136* (30*)	—	—	—		
18	—	—	—	55 (12)	118 (26)	136* (30*)	—	—	—	—	77 (17)	136* (30*)	—	—	—	—	68 (15)	109 (24)	136* (30*)	—	—	—		
19	—	—	—	—	114 (25)	136* (30*)	—	—	—	—	73 (16)	136* (30*)	—	—	—	—	64 (14)	105 (23)	136* (30*)	—	—	—		
20	—	—	—	—	109 (24)	136* (30*)	—	—	—	—	68 (15)	136* (30*)	—	—	—	—	59 (13)	100 (22)	136* (30*)	—	—	—		
23	—	—	—	—	91 (20)	136* (30*)	—	—	—	—	64 (14)	132 (29)	136* (30*)	—	—	—	55 (12)	86 (19)	136* (30*)	—	—	—		
25	—	—	—	—	86 (19)	136* (30*)	—	—	—	—	59 (13)	123 (27)	136* (30*)	—	—	—	77 (17)	136* (30*)	—	—	—	—		
30	—	—	—	—	73 (16)	127 (28)	136* (30*)	—	—	—	—	100 (22)	136* (30*)	—	—	—	64 (14)	136* (30*)	—	—	—	—		
35	—	—	—	—	59 (13)	109 (24)	136* (30*)	—	—	—	—	86 (19)	136* (30*)	—	—	—	55 (12)	123 (27)	136* (30*)	—	—	—		
40	—	—	—	—	55 (12)	95 (21)	136* (30*)	—	—	—	—	77 (17)	136* (30*)	—	—	—	—	105 (23)	136* (30*)	—	—	—		
45	—	—	—	—	—	86 (19)	136* (30*)	—	—	—	—	68 (15)	123 (27)	136* (30*)	—	—	—	—	95 (21)	136* (30*)	—	—		
50	—	—	—	—	—	77 (17)	123 (27)	136* (30*)	—	—	—	—	59 (13)	109 (24)	136* (30*)	—	—	—	86 (19)	136* (30*)	—	—		
55	—	—	—	—	—	68 (15)	114 (25)	136* (30*)	—	—	—	—	100 (22)	136* (30*)	—	—	—	—	77 (17)	136* (30*)	—	—		
60	—	—	—	—	—	64 (14)	105 (23)	136* (30*)	—	—	—	—	91 (20)	136* (30*)	—	—	—	—	68 (15)	127 (28)	136* (30*)	—		
65	—	—	—	—	—	59 (13)	95 (21)	136* (30*)	—	—	—	—	82 (18)	136* (30*)	—	—	—	—	64 (14)	118 (26)	136* (30*)	—		
70	—	—	—	—	—	55 (12)	91 (20)	136* (30*)	—	—	—	—	77 (17)	127 (28)	—	—	—	—	59 (13)	109 (24)	136* (30*)	—		

\*Maximum flow obtainable from 1 notch with 152mm (6") water depth at drain.



# Select Proper Horizontal Storm Drain Piping

**TABLE III - TO BE USED WHEN ROOF STORM WATER RUN OFF AND OTHER SURFACE WATER RUN OFF IS BEING CONSOLIDATED INTO ONE COMMON MAIN HORIZONTAL STORM SEWER.**

Flow capacity of vertical leaders litres per minute (gallons per minute)

Pipe Size	Maximum Capacity L.P.M. (G.P.M.)
50mm (2")	136 (30)
75mm (3")	409 (90)
100mm (4")	864 (190)
†125mm (5")	1582 (348)
150mm (6")	2550 (561)

†In some areas 125mm (5") drainage pipe may not be available.

## SCUPPER AND OVERFLOW DRAINS

Roofing members and understructures, weakened by seepage and rot resulting from improper drainage and roof construction can give away under the weight of rapidly accumulated water during flash storms. Thus, it is recommended, and often required by building codes, to install scuppers and overflow drains in parapet-type roofs. Properly selected and sized scuppers and overflow drains are vital to a well-engineered drainage system to prevent excessive loading, erosion, seepage and rotting.

Flow capacity of horizontal storm sewers litres per minute (gallons per minute).

Pipe Size	Slope per 305mm (1'0")		
	3mm (1/8")	6mm (1/4")	13mm (1/2")
75mm (3")	163 (36)	232 (51)	327 (72)
100mm (4")	355 (78)	505 (111)	714 (157)
†125mm (5")	646 (142)	914 (201)	1291 (284)
150mm (6")	1050 (231)	1487 (327)	2100 (462)
200mm (8")	2264 (498)	3205 (705)	4528 (996)
250mm (10")	4100 (902)	5796 (1275)	8201 (1804)
300mm (12")	6669 (1467)	9437 (2076)	13338 (2934)
375mm (15")	12120 (2666)	17157 (3774)	24239 (5332)

Note: Although pipe size calculations should be based on accumulated flow rate, local by-laws should be referred to for minimum pipe size requirements and roof drain spacing.

# Selecta-Drain Chart



LOCATION	SQUARE METRE (SQUARE FOOT)	ROOF LOAD FACTOR KGS. (LBS.)	TOTAL ROOF SLOPE											
			DEAD LEVEL			51mm (2") RISE			102mm (4") RISE			152mm (6") RISE		
			L.P.M. (G.P.M.) Discharge	Draindown Time Hrs.	mm (in.) Water Depth	L.P.M. (G.P.M.) Discharge	Draindown Time Hrs.	mm (in.) Water Depth	L.P.M. (G.P.M.) Discharge	Draindown Time Hrs.	mm (in.) Water Depth	L.P.M. (G.P.M.) Discharge	Draindown Time Hrs.	mm (in.) Water Depth
Calgary, Alberta	232 (2,500)	4.7 (10.4)	45.5 (10)	7	51 (2)	57 (12.5)	6	63.5 (2.5)	72.5 (16)	4	81.5 (3.2)	86.5 (19)	3.2	96.5 (3.8)
	465 (5,000)	5.9 (13)	57 (12.5)	17	63.5 (2.5)	66 (14.5)	14	73.5 (2.9)	82 (18)	9	91.5 (3.6)	97.5 (21.5)	7.5	109 (4.3)
	697 (7,500)	6.4 (14)	61.5 (13.5)	28	68.5 (2.7)	72.5 (16)	22	81.5 (3.2)	88.5 (19.5)	15	99 (3.9)	104.5 (23)	12	117 (4.6)
	929 (10,000)	6.8 (15.1)	66 (14.5)	38	73.5 (2.9)	77.5 (17)	31	86.5 (3.4)	93 (20.5)	22	104 (4.1)	109 (24)	17	122 (4.8)
Edmonton, Alberta	232 (2,500)	4.5 (9.9)	43 (9.5)	7	48.5 (1.9)	57 (12.5)	6	63.5 (2.5)	72.5 (16)	4	81.5 (3.2)	82 (18)	3	91.5 (3.6)
	465 (5,000)	5.9 (13)	57 (12.5)	17	63.5 (2.5)	68 (15)	14.5	76 (3)	84 (18.5)	9.5	94 (3.7)	97.5 (21.5)	7.5	109 (4.3)
	697 (7,500)	6.6 (14.5)	63.5 (14)	28	71 (2.8)	75 (16.5)	24	84 (3.3)	97.5 (21.5)	16	104 (4.1)	107 (23.5)	12	119.5 (4.7)
	929 (10,000)	7.1 (15.6)	68 (15)	38	76 (3.0)	79.5 (17.5)	32	89 (3.5)	100 (22)	22	112 (4.4)	113.5 (25)	18	127 (5.0)
Penticton, British Columbia	232 (2,500)	3.8 (8.3)	36.5 (8)	6	40.5 (1.6)	38.5 (8.5)	4	43 (1.7)	52.5 (11.5)	3	58.5 (2.3)	61.5 (13.5)	2.3	68.5 (2.7)
	465 (5,000)	4.0 (8.8)	38.5 (8.5)	13	43 (1.7)	41 (9)	9	45.5 (1.8)	57 (12.5)	6	63.5 (2.5)	68 (15)	5	76 (3)
	697 (7,500)	4.2 (9.3)	41 (9)	21	45.5 (1.8)	43 (9.5)	14.5	48.5 (1.9)	61.5 (13.5)	10.5	68.5 (2.7)	72.5 (16)	8	81.5 (3.2)
	929 (10,000)	4.2 (9.3)	41 (9)	27	45.5 (1.8)	45.5 (10)	20	51 (2)	63.5 (14)	14	71 (2.8)	75 (16.5)	11	84 (3.3)
Vancouver, British Columbia	232 (2,500)	3.3 (7.3)	32 (7)	5.5	35.5 (1.4)	38.5 (8.5)	4	43 (1.7)	47.5 (10.5)	2.8	53.5 (2.1)	57 (12.5)	2	63.5 (2.5)
	465 (5,000)	4.0 (8.8)	38.5 (8.5)	13	43 (1.7)	45.5 (10)	10	51 (2)	57 (12.5)	6	63.5 (2.5)	68 (15)	5	76 (3)
	697 (7,500)	4.5 (9.9)	43 (9.5)	22	48.5 (1.9)	50 (11)	17	56 (2.2)	63.5 (14)	11	71 (2.8)	75 (16.5)	8.5	84 (3.3)
	929 (10,000)	4.9 (10.9)	47.5 (10.5)	30	53.5 (2.1)	54.5 (12)	24	61 (2.4)	68 (15)	15	76 (3)	79.5 (17.5)	12	89 (3.5)
Victoria, British Columbia	232 (2,500)	3.3 (7.3)	32 (7)	5.5	35.5 (1.4)	38.5 (8.5)	4	43 (1.7)	43 (9.5)	2.5	48.5 (1.9)	54.5 (12)	2	61 (2.4)
	465 (5,000)	4.0 (8.8)	38.5 (8.5)	13	43 (1.7)	45.5 (10)	10	51 (2)	54.5 (12)	6	61 (2.4)	68 (15)	5	76 (3)
	697 (7,500)	4.5 (9.9)	43 (9.5)	22	48.5 (1.9)	50 (11)	16	56 (2.2)	59 (13)	10	66 (2.6)	75 (16.5)	8	84 (3.3)
	929 (10,000)	4.7 (10.4)	45.5 (10)	30	51 (2)	54.5 (12)	23	61 (2.4)	63.5 (14)	14	71 (2.8)	79.5 (17.5)	12	89 (3.5)
Brandon, Manitoba	232 (2,500)	5.9 (13)	57 (12.5)	8	63.5 (2.5)	68 (15)	7	76 (3)	82 (18)	4.5	91.5 (3.6)	92.5 (21)	3.5	106.5 (4.2)
	465 (5,000)	7.3 (16.1)	73 (16)	20	81.5 (3.2)	84 (18.5)	17	94 (3.7)	97.5 (21.5)	11	109 (4.3)	113.5 (25)	8.5	127 (5)
	697 (7,500)	8.3 (18.2)	79.5 (17.5)	32	89 (3.5)	93 (20.5)	27	104 (4.1)	107 (23.5)	19	119.5 (4.7)	125 (27.5)	15	139.5 (5.5)
	929 (10,000)	9.0 (19.8)	86.5 (19)	43	96.5 (3.8)	100 (22)	38	112 (4.4)	113.5 (25)	26	127 (5.0)	132 (29)	21	147.5 (5.8)
Winnipeg, Manitoba	232 (2,500)	4.7 (10.4)	45.5 (10)	7	51 (2)	57 (12.5)	6	63.5 (2.5)	75 (16.5)	4	84 (3.3)	86.5 (19)	3.2	96.5 (3.8)
	465 (5,000)	5.9 (13)	57 (12.5)	17	63.5 (2.5)	68 (15)	15	76 (3)	84 (18.5)	10	94 (3.7)	100 (22)	7.5	112 (4.4)
	697 (7,500)	6.6 (14.5)	63.5 (14)	28	71 (2.8)	75 (16.5)	24	84 (3.3)	93 (20.5)	16	104 (4.1)	107 (23.5)	12	119.5 (4.7)
	929 (10,000)	7.1 (15.6)	68 (15)	39	76 (3)	82 (18)	32	91.5 (3.6)	97.5 (21.5)	22	109 (4.3)	113.5 (25)	17	127 (5.0)
Campbellton, New Brunswick	232 (2,500)	6.4 (14)	62 (13.5)	9	68.5 (2.7)	70.5 (15.5)	7	78.5 (3.1)	79.5 (17.5)	4.5	89 (3.5)	91 (20)	3.5	101.5 (4.0)
	465 (5,000)	9.0 (19.8)	86.5 (19)	22	96.5 (3.8)	91 (20)	18	101.5 (4)	102.5 (22.5)	12	115 (4.5)	113.5 (25)	9	127 (5.0)
	697 (7,500)	10.4 (22.9)	100 (22)	35	112 (4.4)	102.5 (22.5)	28	114.5 (4.5)	118 (26)	20	132 (5.2)	132 (29)	15	147.5 (5.8)
	929 (10,000)	11.3 (25)	109 (24)	47	122 (4.8)	111.5 (24.5)	40	124.5 (4.9)	127.5 (28)	29	142 (5.6)	141 (31)	22	157.5 (6.2)

# Selecta-Drain Chart



LOCATION	SQUARE METRE (SQUARE FOOT)	ROOF LOAD FACTOR KGS. (LBS.)	TOTAL ROOF SLOPE											
			DEAD LEVEL			51mm (2") RISE			102mm (4") RISE			152mm (6") RISE		
			L.P.M. (G.P.M.) Discharge	Draindown Time Hrs.	mm (in.) Water Depth	L.P.M. (G.P.M.) Discharge	Draindown Time Hrs.	mm (in.) Water Depth	L.P.M. (G.P.M.) Discharge	Draindown Time Hrs.	mm (in.) Water Depth	L.P.M. (G.P.M.) Discharge	Draindown Time Hrs.	mm (in.) Water Depth
Chatham, New Brunswick	232 (2,500)	4.5 (9.9)	43 (9.5)	7	48.5 (1.9)	52.5 (11.5)	5.5	58.5 (2.3)	63.5 (14)	3.5	71 (2.8)	77.5 (17)	2.9	86.5 (3.4)
	465 (5,000)	5.7 (12.5)	54.5 (12)	16	61 (2.4)	63.5 (14)	13	71 (2.8)	77.5 (17)	9	86.5 (3.4)	91 (20)	7	101.5 (4.0)
	697 (7,500)	6.4 (14)	61.5 (13.5)	27	68.5 (2.7)	68 (15)	22	76 (3)	84 (18.5)	14	94 (3.7)	102.5 (22.5)	12	114.5 (4.5)
	929 (10,000)	6.6 (14.6)	63.5 (14)	37	71 (2.8)	75 (16.5)	30	84 (3.3)	91 (20)	20	101.5 (4.0)	107 (23.5)	16	119.5 (4.7)
Moncton, New Brunswick	232 (2,500)	4.3 (9.4)	41 (9)	7	45.5 (1.8)	54.5 (12)	6	61 (2.4)	63.5 (14)	3.5	71 (2.8)	72.5 (16)	2.7	81.5 (3.2)
	465 (5,000)	5.9 (13)	57 (12.5)	17	63.5 (2.5)	68 (15)	14	76 (3)	82 (18)	9	91.5 (3.6)	93 (20.5)	7	104 (4.1)
	697 (7,500)	6.6 (14.6)	63.5 (14)	28	71 (2.8)	79.5 (17.5)	24	89 (3.5)	93 (20.5)	16	104 (4.1)	104.5 (23)	12	117 (4.6)
	929 (10,000)	7.5 (16.6)	73.5 (16)	39	81.5 (3.2)	84 (18.5)	34	94 (3.7)	100 (22)	23	112 (4.4)	113.5 (25)	17	127 (5.0)
Saint John, New Brunswick	232 (2,500)	5.7 (12.5)	54.5 (12)	8	61 (2.4)	57 (12.5)	6	63.5 (2.5)	75 (16.5)	4	84 (3.3)	86.5 (19)	3	96.5 (3.8)
	465 (5,000)	7.5 (16.6)	72.5 (16)	20	81.5 (3.2)	79.5 (17.5)	16	89 (3.5)	95.5 (21)	11	106.5 (4.2)	104.5 (23)	8	117 (4.6)
	697 (7,500)	8.7 (19.2)	84 (18.5)	32	94 (3.7)	93 (20.5)	27	104 (4.1)	107 (23.5)	19	119.5 (4.7)	118 (26)	13.5	132 (5.2)
	929 (10,000)	9.7 (21.3)	93 (20.5)	44	104 (4.1)	104.5 (23)	38	117 (4.6)	113.5 (25)	27	127 (5.0)	127.5 (28)	20	142 (5.6)
Gander, Newfoundland	232 (2,500)	3.5 (7.8)	34 (7.5)	5.5	38 (1.5)	45.5 (10)	5	51 (2.0)	57 (12.5)	3.5	63.5 (2.5)	68 (15)	2.5	76 (3.0)
	465 (5,000)	4.7 (10.4)	45.5 (10)	15	51 (2.0)	57 (12.5)	12	63.5 (2.5)	72.5 (16)	8	81.5 (3.2)	82 (18)	6.5	91.5 (3.6)
	697 (7,500)	5.7 (12.5)	54.5 (12)	25	61 (2.4)	63.5 (14)	21	71 (2.8)	79.5 (17.5)	13.5	89 (3.5)	93 (20.5)	11	104 (4.1)
	929 (10,000)	6.1 (13.5)	59 (13)	35	66 (2.6)	70.5 (15.5)	29	78.5 (3.1)	84 (18.5)	19	94 (3.7)	100 (22)	15	112 (4.4)
St. Andrews, Newfoundland	232 (2,500)	3.5 (7.8)	34 (7.5)	5.5	38 (1.5)	45.5 (10)	5	51 (2.0)	59 (13)	3.5	66 (2.6)	63.5 (14)	2.5	71 (2.8)
	465 (5,000)	5.2 (11.4)	47.5 (10.5)	15	53.5 (2.1)	59 (13)	13	66 (2.6)	72.5 (16)	8	81.5 (3.2)	79.5 (17.5)	6	89 (3.5)
	697 (7,500)	5.9 (13)	57 (12.5)	26	63.5 (2.5)	66 (14.5)	21	73.5 (2.9)	82 (18)	14	91.5 (3.6)	88.5 (19.5)	10	99 (3.9)
	929 (10,000)	6.6 (14.6)	63.5 (14)	36	71 (2.8)	72.5 (16)	30	81.5 (3.2)	86.5 (19)	20	96.5 (3.8)	95.5 (21)	14.5	106.5 (4.2)
St. John's, Newfoundland	232 (2,500)	5.9 (13)	57 (12.5)	8	63.5 (2.6)	68 (15)	7	76 (3.0)	77.5 (17)	4.5	86.5 (3.4)	86.5 (19)	3.2	96.5 (3.8)
	465 (5,000)	8.5 (18.7)	82 (18)	21	91.5 (3.6)	91 (20)	18	101 (4.0)	100 (22)	11	112 (4.4)	113.5 (25)	9	127 (5.0)
	697 (7,500)	10.6 (23.4)	102.5 (22.5)	34	114.5 (4.5)	109 (24)	29	122 (4.8)	122.5 (27)	21	137 (5.4)	132 (29)	15	147.5 (5.8)
	929 (10,000)	11.8 (26)	113.5 (25)	48	127 (5.0)	129.5 (28.5)	43	145 (5.7)	143 (31.5)	33	160 (6.3)	150 (33)	24	167.5 (6.6)
Torbay, Newfoundland	232 (2,500)	4.9 (10.9)	47.5 (10.5)	7.5	53.5 (2.1)	61.5 (13.5)	6.5	68.5 (2.7)	75 (16.5)	4	84 (3.3)	84 (18.5)	3	94 (3.7)
	465 (5,000)	6.4 (14)	61.5 (13.5)	18	68.5 (2.7)	75 (16.5)	15.5	84 (3.3)	88.5 (19.5)	10	99 (3.9)	102.5 (22.5)	8	114.5 (4.5)
	697 (7,500)	7.3 (16.1)	70.5 (15.5)	29	78.5 (3.1)	84 (18.5)	25	94 (3.7)	100 (22)	17.5	112 (4.4)	113.5 (25)	13	127 (5)
	929 (10,000)	8.0 (17.7)	77.5 (17)	40	86.5 (3.4)	88.5 (19.5)	34	99 (3.9)	107 (23.5)	24	119.5 (4.7)	122.5 (27)	19	137 (5.4)
Halifax, Nova Scotia	232 (2,500)	5.9 (13)	57 (12.5)	8	63.5 (2.5)	68 (15)	7	76 (3.0)	77.5 (17)	4.5	86.5 (3.4)	86.5 (19)	3.2	96.5 (3.8)
	465 (5,000)	8.5 (18.7)	82 (18)	21	91.5 (3.6)	91 (20)	18	101.5 (4.0)	100 (22)	11	112 (4.4)	113.5 (25)	9	127 (5.0)
	697 (7,500)	10.6 (23.4)	102.5 (22.5)	34	114.5 (4.5)	109 (24)	29	122 (4.8)	122.5 (27)	21	137 (5.4)	132 (29)	15	147.5 (5.8)
	929 (10,000)	11.8 (26)	113.5 (25)	48	127 (5.0)	129.5 (28.5)	43	145 (5.7)	143 (31.5)	33	160 (6.3)	150 (33)	24	167.5 (6.6)

# Selecta-Drain Chart



LOCATION	SQUARE METRE (SQUARE FOOT)	ROOF LOAD FACTOR KGS. (LBS.)	TOTAL ROOF SLOPE											
			DEAD LEVEL			51mm (2") RISE			102mm (4") RISE			152mm (6") RISE		
			L.P.M. (G.P.M.) Discharge	Draindown Time Hrs.	mm (in.) Water Depth	L.P.M. (G.P.M.) Discharge	Draindown Time Hrs.	mm (in.) Water Depth	L.P.M. (G.P.M.) Discharge	Draindown Time Hrs.	mm (in.) Water Depth	L.P.M. (G.P.M.) Discharge	Draindown Time Hrs.	mm (in.) Water Depth
Sydney, Nova Scotia	232 (2,500)	4.3 (9.4)	41 (9)	6.5	45.5 (1.8)	45.5 (10)	5	51 (2.0)	57 (12.5)	3.5	6.5 (2.5)	68 (15)	2.5	76 (3)
	465 (5,000)	5.7 (12.5)	54.5 (12)	16	61 (2.4)	59 (13)	13	66 (2.6)	75 (16.5)	8	84 (3.3)	84 (18.5)	6.5	94 (3.7)
	697 (7,500)	6.4 (14)	61.5 (13.5)	28	68.5 (2.7)	68 (15)	22	76 (3)	84 (18.5)	14	94 (3.7)	97.5 (21.5)	11	109 (4.3)
	929 (10,000)	7.1 (15.6)	68 (15)	38	76 (3)	75 (16.5)	30	84 (3.3)	91 (20)	20	101.5 (4)	104.5 (23)	16	117 (4.6)
Yarmouth, Nova Scotia	232 (2,500)	6.4 (14)	61.5 (13.5)	9	68.5 (2.7)	70.5 (15.5)	7.5	78.5 (3.1)	82 (18)	4.5	91.5 (3.6)	91 (20)	3.5	101.5 (4)
	465 (5,000)	8.3 (18.2)	79.5 (17.5)	21	89 (3.5)	88.5 (19.5)	18	99 (3.9)	104.5 (23)	12	117 (4.6)	116 (25.5)	9	129.5 (5.1)
	697 (7,500)	9.4 (20.8)	91 (20)	34	101.5 (4)	102.5 (22.5)	29	114.5 (4.5)	118 (26)	21	132 (5.2)	132 (29)	15	147.5 (5.8)
	929 (10,000)	10.4 (22.9)	100 (22)	45	112 (4.4)	109 (24)	41	122 (4.8)	129.5 (28.5)	29	145 (5.7)	141 (31)	22	157.5 (6.2)
Thunder Bay, Ontario	232 (2,500)	4.9 (10.9)	47.5 (10.5)	7.5	53.5 (2.1)	61.5 (13.5)	6.5	68.5 (2.7)	75 (16.5)	4	84 (3.3)	88.5 (19.5)	3.5	91.5 (3.6)
	465 (5,000)	6.1 (13.5)	59 (13)	18	66 (2.6)	72.5 (16)	15	81.5 (3.2)	86.5 (19)	9.5	96.5 (3.8)	102.5 (22.5)	7.5	114.5 (4.5)
	697 (7,500)	6.6 (14.6)	63.5 (14)	28	71 (2.8)	77.5 (17)	24	86.5 (3.4)	93 (20.5)	16	104 (4.1)	109 (24)	13	122 (4.8)
	929 (10,000)	7.1 (15.6)	68 (15)	38	76 (3)	84 (18.5)	33	94 (3.7)	97.5 (21.5)	22	109 (4.3)	116 (25.5)	18	129.5 (5.1)
Guelph, Ontario	232 (2,500)	5.7 (12.5)	54.5 (12)	8	61 (2.4)	63.5 (14)	7	71 (2.8)	86.5 (19)	5	96.5 (3.8)	100 (22)	3.7	112 (4.4)
	465 (5,000)	6.6 (14.6)	63.5 (14)	19	71 (2.8)	75 (16.5)	15.5	84 (3.3)	97.5 (21.5)	11	109 (4.3)	116 (25.5)	9	129.5 (5.1)
	697 (7,500)	7.3 (16.1)	70.5 (15.5)	29	78.5 (3.1)	82 (18)	25	91.5 (3.6)	104.5 (23)	18	117 (4.6)	125 (27.5)	14	139.5 (5.5)
	929 (10,000)	8.0 (17.7)	77.5 (17)	40	86.5 (3.4)	84 (18.5)	34	94 (3.7)	109 (24)	26	122 (4.8)	132 (29)	20	147.5 (5.8)
Hamilton, Ontario	232 (2,500)	5.9 (13)	57 (12.5)	8.5	63.5 (2.5)	72.5 (16)	7.5	81.5 (3.2)	93 (20.5)	5	104 (4.1)	109 (24)	4	122 (4.8)
	465 (5,000)	6.6 (14.6)	63.5 (14)	19	71 (2.8)	79.5 (17.5)	16	89 (3.5)	104.5 (23)	12	117 (4.6)	122.5 (27)	9	137 (5.4)
	697 (7,500)	6.8 (15.1)	66 (14.5)	28	73.5 (2.9)	84 (18.5)	26	94 (3.7)	111.5 (24.5)	20	124.5 (4.9)	127.5 (28)	15	142 (5.6)
	929 (10,000)	7.1 (15.6)	68 (15)	39	76 (3)	86.5 (19)	34	96.5 (3.8)	116 (25.5)	27	129.5 (5.1)	134 (29.5)	21	150 (5.9)
Kingston, Ontario	232 (2,500)	6.4 (14)	61.5 (13.5)	9	68.5 (2.7)	77.5 (17)	8	86.5 (3.4)	91 (20)	5	101.5 (4)	109 (24)	4	122 (4.8)
	465 (5,000)	7.5 (16.6)	72.5 (16)	20	81.5 (3.2)	86.5 (19)	18	96.5 (3.8)	104.5 (23)	12	117 (4.6)	122.5 (27)	9.5	137 (5.4)
	697 (7,500)	8.5 (18.7)	82 (18)	31	91.5 (3.6)	93 (20.5)	28	104 (4.1)	111.5 (24.5)	20	124.5 (4.9)	132 (29)	15	147.5 (5.8)
	929 (10,000)	8.7 (19.2)	86.5 (19)	42	96.5 (3.8)	97.5 (21.5)	38	109 (4.3)	116 (25.5)	27	129.5 (5.1)	68 (15)	21	152.5 (6)
London, Ontario	232 (2,500)	6.1 (13.5)	59 (13)	8.5	66 (2.6)	72.5 (16)	7.5	81.5 (3.2)	88.5 (19.5)	5	99 (3.9)	107 (23.5)	4	119.5 (4.7)
	465 (5,000)	7.1 (15.6)	68 (15)	20	76 (3)	84 (18.5)	17	94 (3.7)	102.5 (22.5)	12	114.5 (4.5)	122.5 (27)	9.5	137 (5.4)
	697 (7,500)	8.0 (17.7)	77.5 (17)	30	86.5 (3.4)	88.5 (19.5)	27	99 (3.9)	109 (24)	19	122 (4.8)	129.5 (28.5)	15	145 (5.7)
	929 (10,000)	8.5 (18.7)	82 (18)	41	91.5 (3.6)	91 (20)	36	101.5 (4)	113.5 (25)	27	127 (5)	134 (29.5)	21	150 (5.9)
North Bay, Ontario	232 (2,500)	5.7 (12.5)	54.5 (12)	8	61 (2.4)	68 (15)	7	76 (3)	86.5 (19)	5	96.5 (3.8)	100 (22)	3.8	112 (4.4)
	465 (5,000)	6.6 (14.6)	63.5 (14)	19	71 (2.8)	79.5 (17.5)	16	89 (3.5)	97.5 (21.5)	11	109 (4.3)	113.5 (25)	9	127 (5)
	697 (7,500)	7.5 (16.6)	72.5 (16)	30	81.5 (3.2)	86.5 (19)	26	96.5 (3.8)	107 (23.5)	19	119.5 (4.7)	122.5 (27)	14	137 (5.4)
	929 (10,000)	8.3 (18.2)	77.5 (17)	40	86.5 (3.4)	93 (20.5)	36	104 (4.1)	111.5 (24.5)	26	124.5 (4.9)	127.5 (28)	20	142 (5.6)

# Selecta-Drain Chart



LOCATION	SQUARE METRE (SQUARE FOOT)	ROOF LOAD FACTOR KGS. (LBS.)	TOTAL ROOF SLOPE											
			DEAD LEVEL			51mm (2") RISE			102mm (4") RISE			152mm (6") RISE		
			L.P.M. (G.P.M.) Discharge	Draindown Time Hrs.	mm (in.) Water Depth	L.P.M. (G.P.M.) Discharge	Draindown Time Hrs.	mm (in.) Water Depth	L.P.M. (G.P.M.) Discharge	Draindown Time Hrs.	mm (in.) Water Depth	L.P.M. (G.P.M.) Discharge	Draindown Time Hrs.	mm (in.) Water Depth
Ottawa, Ontario	232 (2,500)	4.7 (10.4)	45.5 (10)	7	51 (2)	59 (13)	6.5	66 (2.6)	77.5 (17)	4.5	86.5 (3.4)	86.5 (19)	3.2	96.5 (3.8)
	465 (5,000)	5.9 (13)	57 (12.5)	17	63.5 (2.5)	68 (15)	14	76 (3)	86.5 (19)	10	96.5 (3.8)	100 (22)	7.5	112 (4.4)
	697 (7,500)	6.4 (14)	61.5 (13.5)	27	68.5 (2.7)	75 (16.5)	23	84 (3.3)	93 (20.5)	16	104 (4.1)	107 (23.5)	12	119.5 (4.7)
	929 (10,000)	6.6 (14.6)	63.5 (14)	36	71 (2.8)	79.5 (17.5)	32	89 (3.5)	97.5 (21.5)	22	109 (4.3)	113.5 (25)	18	127 (5)
St. Thomas, Ontario	232 (2,500)	5.7 (12.5)	54.5 (12)	8	61 (2.4)	68 (15)	7	76 (3.0)	86.5 (19)	5	96.5 (3.8)	104.5 (23)	4	117 (4.6)
	465 (5,000)	6.6 (14.6)	63.5 (14)	19	71 (2.8)	77.5 (17)	16	86.5 (3.4)	97.5 (21.5)	11	109 (4.3)	118 (26)	9	132 (5.2)
	697 (7,500)	7.1 (16.6)	68 (15)	29	76 (3.0)	82 (18)	26	91.5 (3.6)	102.5 (22.5)	18	114.5 (4.5)	125 (27.5)	15	139.5 (5.5)
	929 (10,000)	7.5 (16.6)	72.5 (16)	40	81.5 (3.2)	86.5 (19)	34	96.5 (3.8)	107 (23.5)	24	119.5 (4.7)	132 (29)	20	147.5 (5.8)
Timmins, Ontario	232 (2,500)	4.3 (9.4)	41 (9)	7	45.5 (1.8)	57 (12.5)	6	63.5 (2.5)	72.5 (16)	4	81.5 (3.2)	86.5 (19)	3.3	96.5 (3.8)
	465 (5,000)	5.7 (12.5)	54.5 (12)	16	61 (2.4)	63.5 (14)	14	71 (2.8)	82 (18)	9	91.5 (3.6)	97.5 (21.5)	7.5	109 (4.3)
	697 (7,500)	6.4 (14)	61.5 (13.5)	27	68.5 (2.7)	70.5 (15.5)	22	78.5 (3.1)	86.5 (19)	15	96.5 (3.8)	104.5 (23)	12	117 (4.6)
	929 (10,000)	6.6 (14.6)	63.5 (14)	36	71 (2.8)	72.5 (16)	30	81.5 (3.2)	91 (20)	21	101.5 (4.0)	109 (24)	17	122 (4.8)
Toronto, Ontario	232 (2,500)	5.7 (12.5)	54.5 (12)	8	61 (2.4)	66 (14.5)	7	73.5 (2.9)	82 (18)	4.5	91.5 (3.6)	97.5 (21.5)	3.5	109 (4.3)
	465 (5,000)	6.8 (15.1)	66 (14.5)	19	73.5 (2.9)	77.5 (17)	16	86.5 (3.4)	93 (20.5)	11	104 (4.1)	111.5 (24.5)	9	124.5 (4.9)
	697 (7,500)	8.0 (17.7)	77.5 (17)	30	86.5 (3.4)	84 (18.5)	26	94 (3.7)	100 (22)	18	112 (4.4)	120.5 (26.5)	14	134.5 (5.3)
	929 (10,000)	8.7 (19.2)	82 (18)	42	91.5 (3.6)	86.5 (19)	34	96.5 (3.8)	104.5 (23)	24	117 (4.6)	127.5 (28)	20	142 (5.6)
Windsor, Ontario	232 (2,500)	6.1 (13.5)	59 (13)	8.5	66 (2.6)	70.5 (15.5)	7.5	78.5 (3.1)	84 (18.5)	4.5	94 (3.7)	107 (23.5)	4	119.5 (4.7)
	465 (5,000)	7.1 (15.6)	68 (15)	20	76 (3.0)	79.5 (17.5)	16	89 (3.5)	97.5 (21.5)	11	109 (4.3)	118 (26)	9	132 (5.2)
	697 (7,500)	8.0 (17.7)	77.5 (17)	30	86.5 (3.4)	86.5 (19)	26	96.5 (3.8)	107 (23.5)	18	119.5 (4.7)	125 (27.5)	15	139.5 (5.5)
	929 (10,000)	8.7 (19.2)	82 (18)	42	91.5 (3.6)	91 (20)	36	101.5 (4.0)	113.5 (25)	26	127 (5.0)	129.5 (28.5)	20	145 (5.7)
Charlottetown, Prince Edward Island	232 (2,500)	4.9 (10.9)	47.5 (10.5)	7.5	53.5 (2.1)	57 (12.5)	6	63.5 (2.5)	68 (15)	3.8	76 (3.0)	79.5 (17.5)	3	89 (3.5)
	465 (5,000)	6.6 (14.6)	63.5 (14)	19	71 (2.8)	75 (16.5)	15.5	84 (3.3)	88.5 (19.5)	10	99 (3.9)	100 (22)	7.5	112 (4.4)
	697 (7,500)	7.8 (17.2)	75 (16.5)	31	84 (3.3)	86.5 (19)	26	96.5 (3.8)	102.5 (22.5)	18	114.5 (4.5)	113.5 (25)	13	127 (5.0)
	929 (10,000)	8.7 (19.2)	84 (18.5)	42	94 (3.7)	97.5 (21.5)	37	106.5 (4.2)	111.5 (24.5)	26	124.5 (4.9)	125 (27.5)	20	139.5 (5.5)
Montreal, Quebec	232 (2,500)	5.2 (11.4)	50 (11)	7.5	56 (2.2)	61.5 (13.5)	7	68.5 (2.7)	79.5 (17.5)	4.5	89 (3.5)	97.5 (21.5)	3.5	109 (4.36)
	465 (5,000)	5.9 (13)	57 (12.5)	17	63.5 (2.5)	70.5 (15.5)	15	78.5 (3.1)	88.5 (19.5)	10	99 (3.9)	109 (24)	8	122 (4.8)
	697 (7,500)	6.1 (13.5)	59 (13)	27	66 (2.6)	72.5 (16)	23	81.5 (3.2)	93 (20.5)	16	104 (4.1)	113.5 (25)	13	127 (5.0)
	929 (10,000)	6.4 (14)	61.5 (13.5)	36	68.5 (2.7)	77.5 (17)	31	86.5 (3.4)	95.5 (21)	22	106.5 (4.2)	120.5 (26.5)	19	134.5 (5.3)
Quebec City, Quebec	232 (2,500)	5.4 (12)	52.5 (11.5)	8	58.5 (2.3)	63.5 (14)	7	71 (2.8)	79.5 (17.5)	4.5	89 (3.5)	97.5 (21.5)	3.5	109 (4.3)
	465 (5,000)	6.4 (14)	61.5 (13.5)	18	68.5 (2.7)	70.5 (15.5)	15	78.5 (3.1)	84 (18.5)	10	94 (3.7)	104.5 (23)	8	117 (4.6)
	697 (7,500)	6.6 (14.6)	63.5 (14)	28	71 (2.8)	72.5 (16)	23	81.5 (3.2)	86.5 (19.5)	15	96.5 (3.8)	107 (23.5)	12	119.5 (4.7)
	929 (10,000)	7.1 (15.6)	68 (15)	37	76 (3.0)	77.5 (17)	31	86.5 (3.4)	88.5 (19.5)	20	99 (3.9)	109 (24)	17	122 (4.8)

# Selecta-Drain Chart



LOCATION	SQUARE METRE (SQUARE FOOT)	ROOF LOAD FACTOR KGS. (LBS.)	TOTAL ROOF SLOPE											
			DEAD LEVEL			51mm (2") RISE			102mm (4") RISE			152mm (6") RISE		
			L.P.M. (G.P.M.) Discharge	Draindown Time Hrs.	mm (in.) Water Depth	L.P.M. (G.P.M.) Discharge	Draindown Time Hrs.	mm (in.) Water Depth	L.P.M. (G.P.M.) Discharge	Draindown Time Hrs.	mm (in.) Water Depth	L.P.M. (G.P.M.) Discharge	Draindown Time Hrs.	mm (in.) Water Depth
Regina, Saskatchewan	232 (2,500)	4.5 (9.9)	43 (9.5)	7	48.5 (1.9)	54.5 (12)	6	61 (2.4)	72.5 (16)	4	81.5 (3.2)	79.5 (17.5)	3	89 (3.5)
	465 (5,000)	6.4 (14)	61.5 (13.5)	18	68.5 (2.7)	68 (15)	14	76 (3.0)	86.5 (19)	10	96.5 (3.8)	97.5 (21.5)	7.5	109 (4.3)
	697 (7,500)	7.3 (16.1)	70.5 (15.5)	29	78.5 (3.1)	77.5 (17)	24	86.5 (3.4)	100 (22)	17	112 (4.4)	109 (24)	12	122 (4.8)
	929 (10,000)	8.3 (18.2)	79.5 (17.5)	40	89 (3.5)	82 (18)	32	91.5 (3.6)	104.5 (23)	24	117 (4.6)	118 (26)	18	132 (5.2)
Saskatoon, Saskatchewan	232 (2,500)	4.0 (8.8)	38.5 (8.5)	6	43 (1.7)	57 (12.5)	6	63.5 (2.5)	66 (14.5)	3.8	73.5 (2.9)	77.5 (17)	2.8	86.5 (3.4)
	465 (5,000)	5.7 (12.5)	54.5 (12)	16	61 (2.4)	68 (15)	14.5	76 (3.0)	82 (18)	9	91.5 (3.6)	95.5 (21)	7	106.5 (4.2)
	697 (7,500)	6.6 (14.6)	63.5 (14)	28	71 (2.8)	75 (16.5)	24	84 (3.3)	91 (20)	16	101.5 (4.0)	104.5 (23)	12	117 (4.6)
	929 (10,000)	7.1 (15.6)	68 (15)	38	76 (3.0)	82 (18)	32	91.5 (3.6)	97.5 (21.5)	22	109 (4.3)	113.5 (25)	18	127 (5.0)





**ZURN INDUSTRIES LIMITED**  
3544 NASHUA DRIVE · MISSISSAUGA, ONT L4V 1L2  
PHONE: 905/405-8272 · FAX: 905/405-1292

©2010 Zurn Industries, LLC

Form 81-31, Rev. 9/10

[www.zurn.com](http://www.zurn.com)

**Appendix H:  
PCSWMM Model Results**

# PCSWMM Report

SWM Report - 100y  
Model 3850 Cambrian Rd - SWM Model.inp

Parsons  
October 16, 2023

# Table of Contents

## Maps

Figure 1: Extent 1 .....	3
--------------------------	---

## Graphs

Figure 2: Controlled vs Uncontrolled .....	4
--	---

## Profiles

Figure 3: Node CB-19_(PROP_STM) to Node EX-MHST .....	5
---	---

Figure 4: Node RY-CB-15_(PROP_STM) to Node EX-MHST .....	6
--	---

Figure 5: Node CHAMBERS to Node EX-MHST .....	7
---	---

Figure 6: Node TD-LoadingDock to Node EX-MHST .....	8
---	---

Figure 7: Node RY-CB-11_(PROP_STM) to Node EX-MHST .....	9
--	---

Figure 8: Node MHST-17_(PROP_STM) to Node EX-MHST .....	10
---	----

## Tables

Table 1: Storages Table Output .....	11
--------------------------------------	----

Table 2: Outfalls Table Output .....	12
--------------------------------------	----

Table 3: Junctions Output Table .....	13
---------------------------------------	----

Table 4: Orifices Output Table .....	13
--------------------------------------	----

Table 5: Outlets Output Table .....	14
-------------------------------------	----

Table 6A: Subcatchments Output Table .....	14
--	----

Table 6B: Subcatchments Output Table .....	15
--	----

Table 7: Conduits Output Table .....	16
--------------------------------------	----



Figure 1: Extent 1

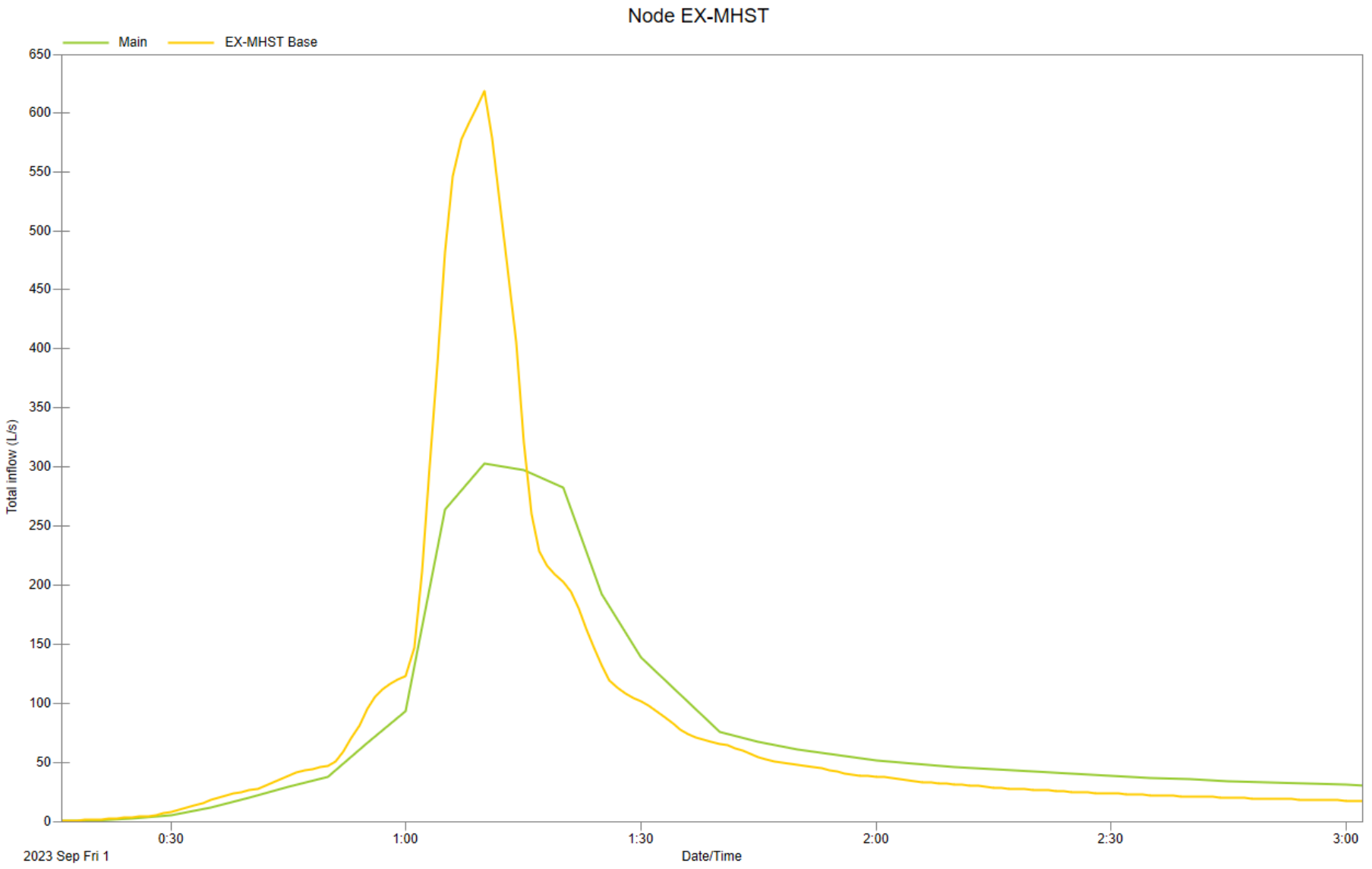

Figure 2: Controlled vs Uncontrolled

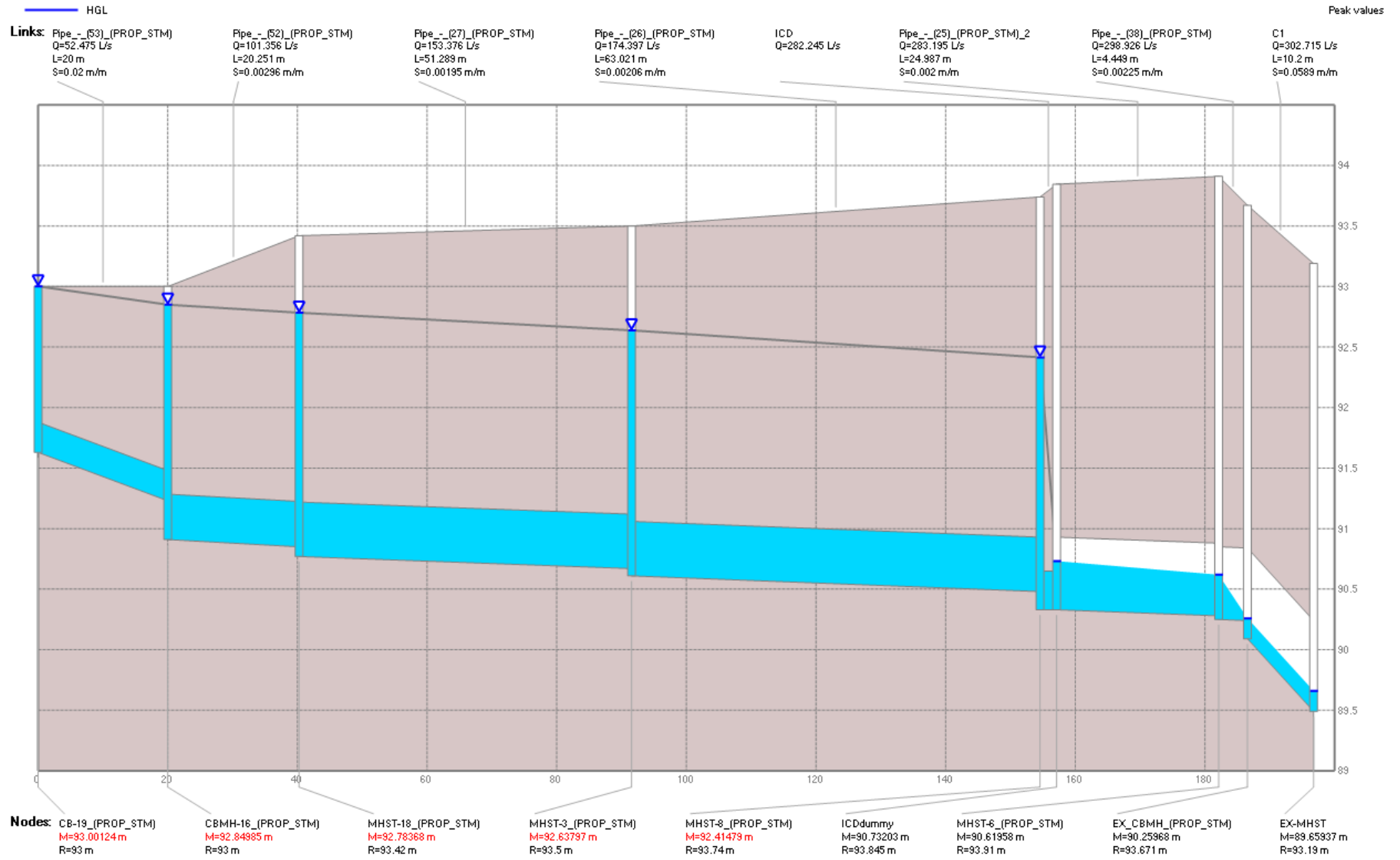

Figure 3: Node CB-19\_(PROP\_STM) to Node EX-MHST

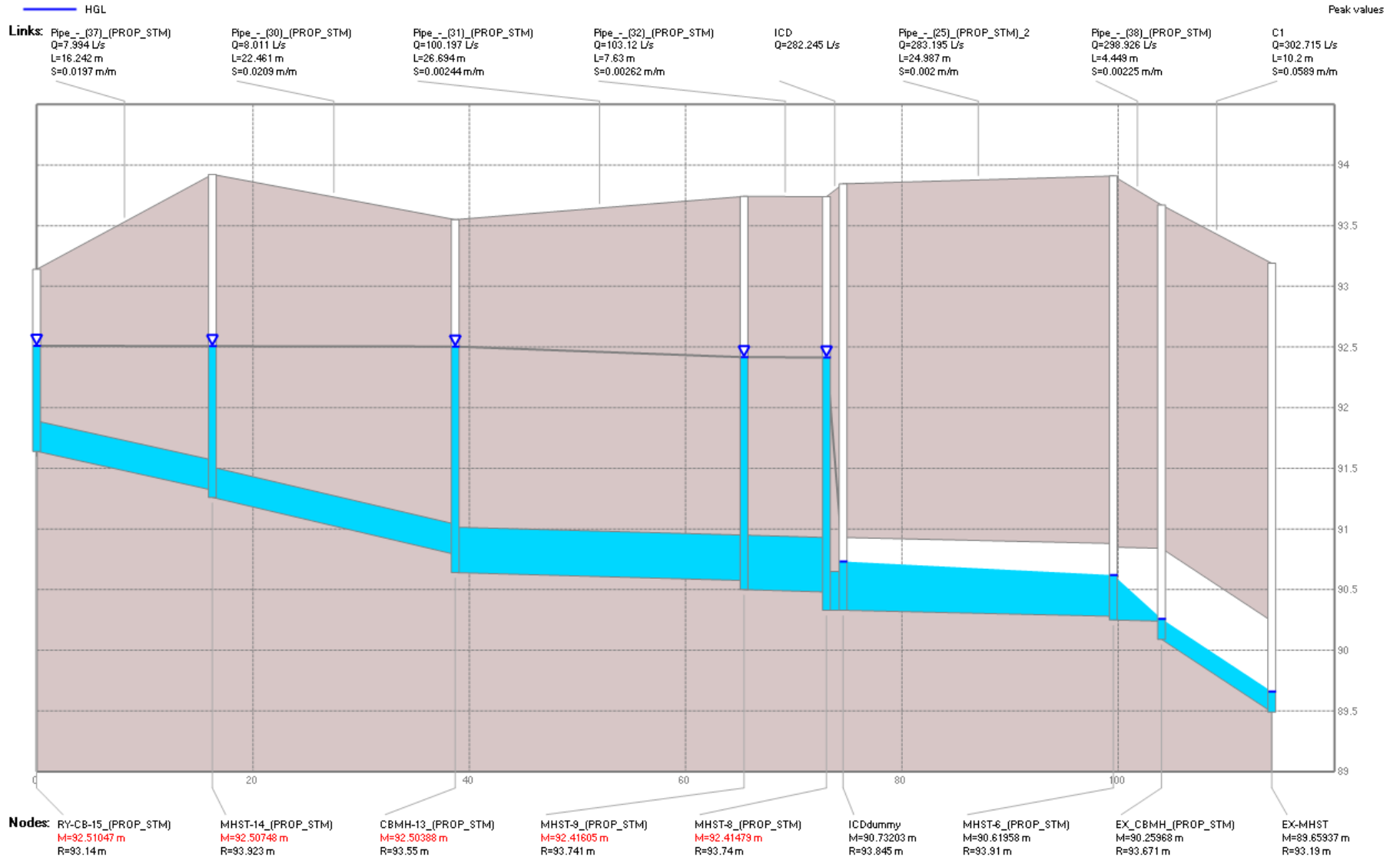

Figure 4: Node RY-CB-15\_(PROP\_STM) to Node EX-MHST



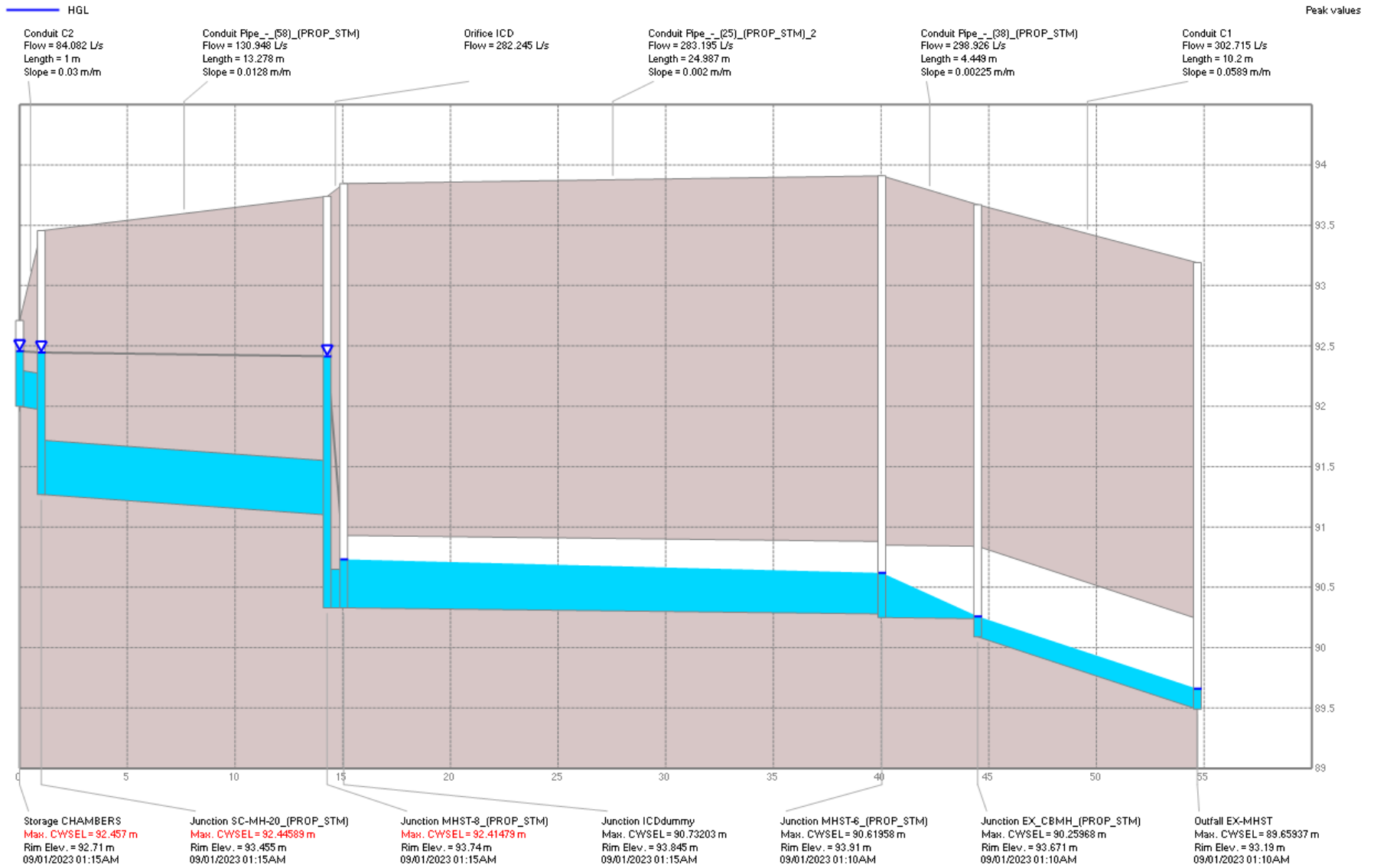

Figure 5: Node CHAMBERS to Node EX-MHST

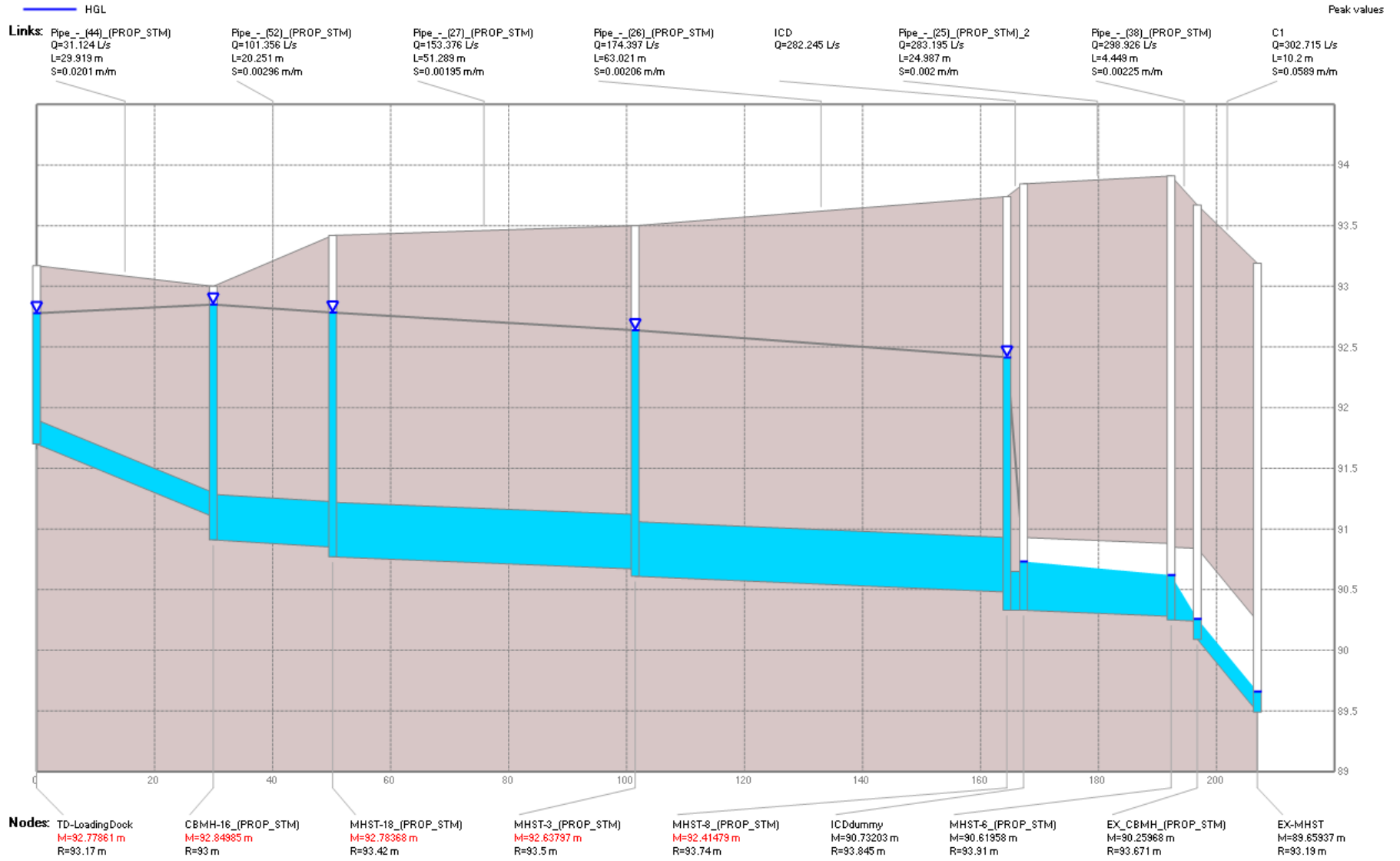

Figure 6: Node TD-LoadingDock to Node EX-MHST

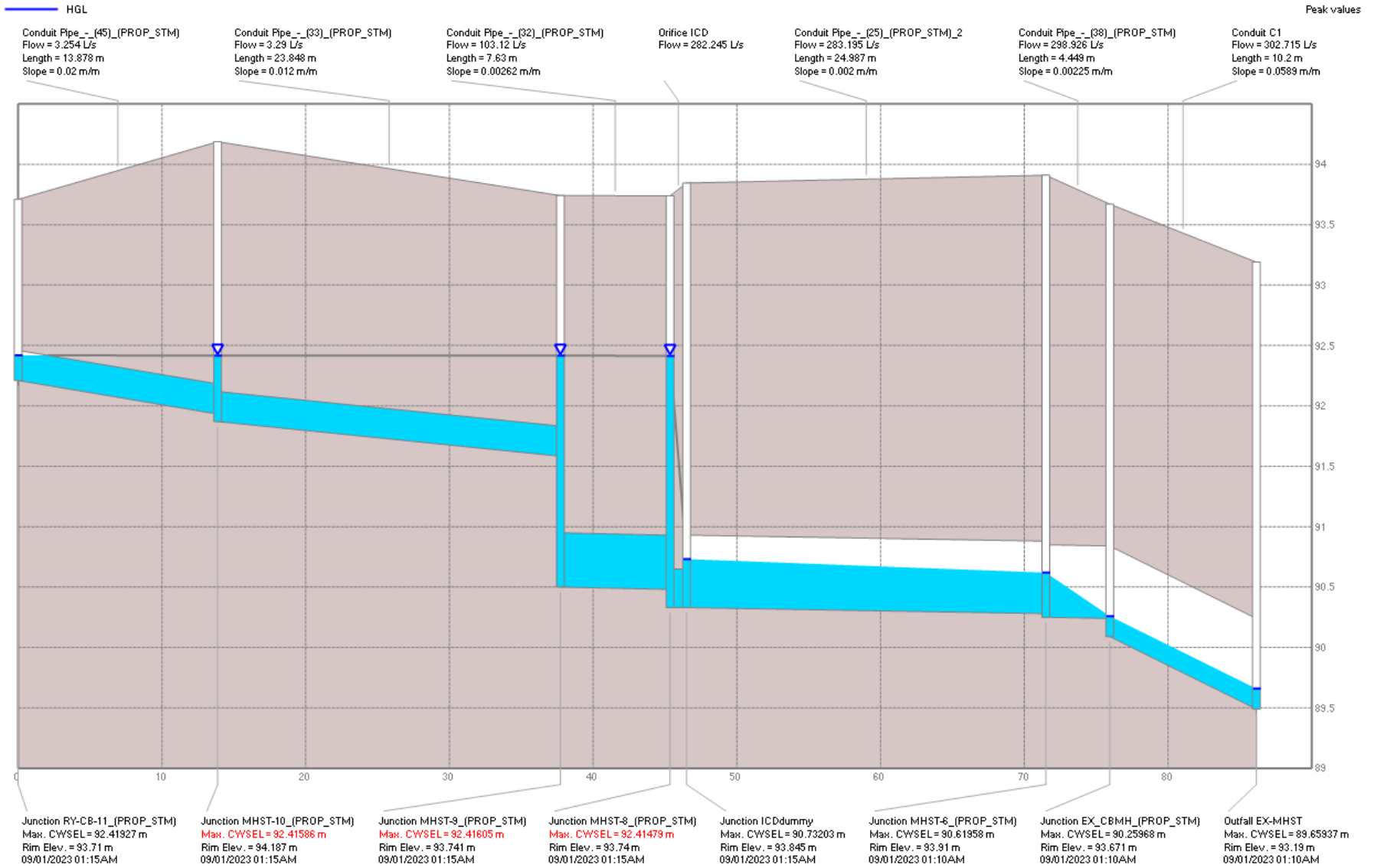

Figure 7: Node RY-CB-11\_(PROP\_STM) to Node EX-MHST

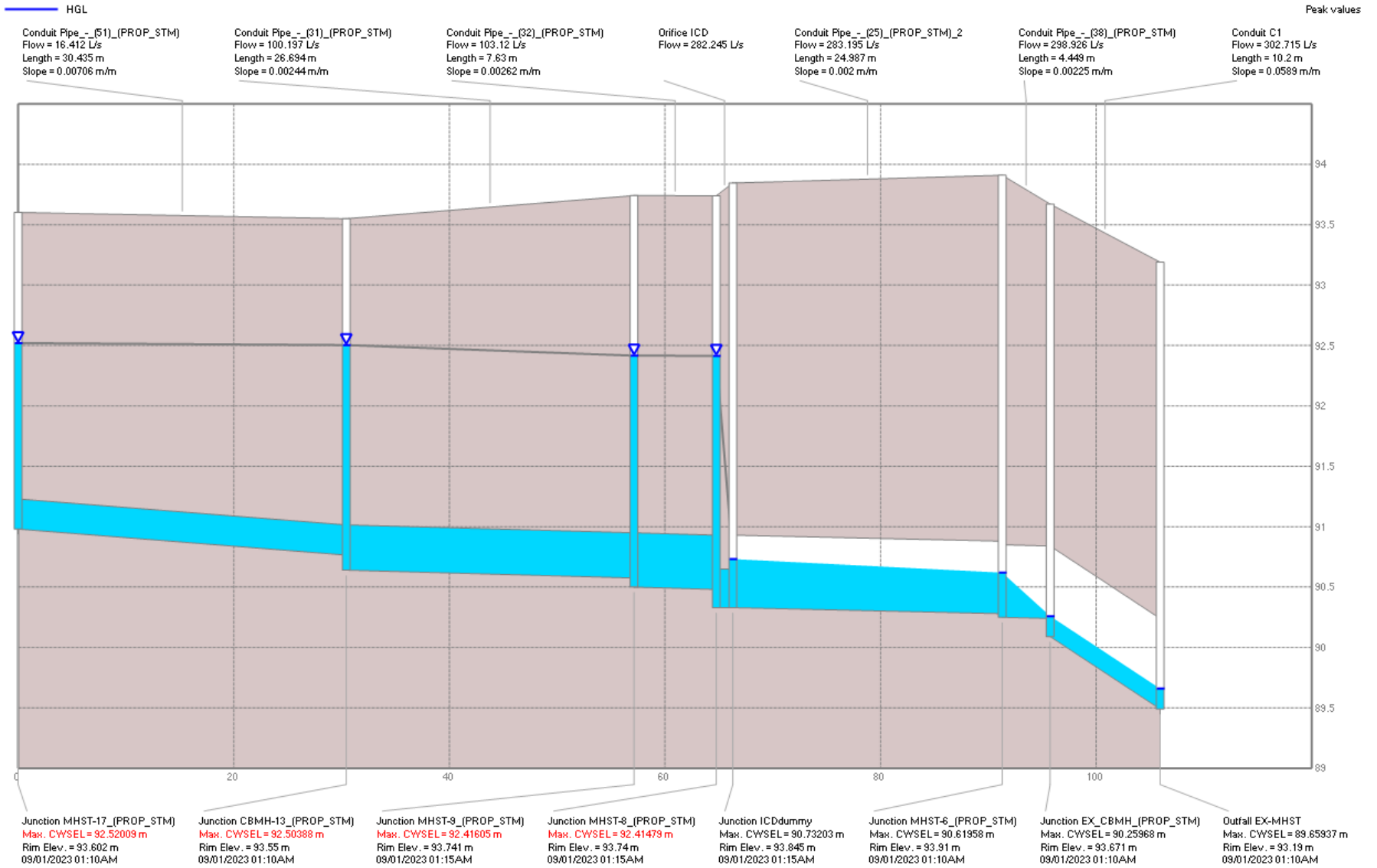

Figure 8: Node MHST-17\_(PROP\_STM) to Node EX-MHST

Table 1: Storages Table Output

Name	Invert Elev. (m)	Rim Elev. (m)	Depth (m)	Avg. Depth (m)	Max. Depth (m)	Max. Total Inflow (L/s)	Avg. Volume (1000 m³)	Avg. Percent Full (%)	Max. Volume (1000 m³)	Max. Percent Full (%)	Max. Outflow (L/s)	Contributing Area (ha)	Max. HGL (m)	Storage Curve
CHAMBERS	92	92.71	0.71	0.02	0.5	145.05	0.002	3	0.054	78	120.56	0	92.5	TABULAR
RD-BLDGA	97	97.15	0.15	0.03	0.11	78	0.014	12	0.062	52	11.56	0.158	97.11	TABULAR
RD-BLDGB	97	97.15	0.15	0.03	0.11	29.49	0.005	11	0.023	51	4.86	0.06	97.11	TABULAR
RD-BLDGC	97	97.15	0.15	0.03	0.11	39.55	0.006	11	0.03	51	6.51	0.08	97.11	TABULAR
RD-BLDGD	97	97.15	0.15	0.03	0.11	20.73	0.004	11	0.016	52	3.27	0.042	97.11	TABULAR
TD-LoadingDock	91.7	93.17	1.47	0.05	1.09	29.4	0	0	0.01	13	31.62	0.023	92.79	TABULAR

Table 2: Outfalls Table Output

Name	Invert Elev. (m)	Rim Elev. (m)	Avg. Depth (m)	Max. Depth (m)	Max. HGL (m)	Rep. Max. Depth (m)	Max. Total Inflow (L/s)	Avg. Flow (L/s)	Contributing Area (ha)	Contributing Imp. Area (ha)
EX-MHST	89.49	93.19	0.03	0.17	89.66	0.17	306	59.63	1.305	1.152

Table 3: Junctions Output Table

Name	Invert Elev. (m)	Rim Elev. (m)	Depth (m)	Avg. Depth (m)	Max. Depth (m)	Max. HGL (m)	Max. Total Inflow (L/s)	Max. Surcharge (m)	Max. Poned Depth (m)	Contributing Area (ha)	Contributing Imp. Area (ha)
CB-19_(PROP_STM)	91.63	93	1.37	0.06	1.37	93	59.59	1.122	0.002	0.129	0.103
CBMH-13_(PROP_STM)	90.64	93.55	2.91	0.14	2.03	92.67	109.49	1.631	0	0.411	0.364
CBMH-16_(PROP_STM)	90.91	93	2.09	0.12	2.09	93	122.18	1.52	0	0.292	0.244
EX_CBMH_(PROP_STM)	90.09	93.671	3.581	0.03	0.17	90.26	306	0	0	1.305	1.152
ICDdummy	90.33	93.845	3.515	0.07	0.41	90.74	287.61	0	0	1.152	1.008
MHST-10_(PROP_STM)	91.87	94.187	2.317	0.02	2.32	94.19	41.31	2.005	0	0.012	0
MHST-14_(PROP_STM)	91.26	93.923	2.663	0.06	1.74	93	44.24	1.435	0	0.029	0
MHST-17_(PROP_STM)	90.98	93.602	2.622	0.1	2.34	93.32	27.8	2.085	0	0.217	0.217
MHST-18_(PROP_STM)	90.77	93.42	2.65	0.13	2.08	92.85	160.91	1.621	0	0.399	0.34
MHST-3_(PROP_STM)	90.61	93.5	2.89	0.14	2.07	92.68	180.72	1.559	0	0.443	0.373
MHST-6_(PROP_STM)	90.25	93.91	3.66	0.07	0.37	90.62	303.17	0	0	1.296	1.147
MHST-8_(PROP_STM)	90.33	93.74	3.41	0.19	2.16	92.49	298.14	0.94	0	1.152	1.008
MHST-9_(PROP_STM)	90.5	93.741	3.241	0.15	2.12	92.62	118.09	0.791	0	0.423	0.364
RY-CB-11_(PROP_STM)	92.21	93.71	1.5	0.01	0.31	92.52	16.93	0.059	0	0.012	0
RY-CB-15_(PROP_STM)	91.64	93.14	1.5	0.04	1.5	93.14	39.28	1.251	0.001	0.029	0
SC-MH-20_(PROP_STM)	91.27	93.455	2.185	0.07	1.23	92.5	159.61	0.231	0	0.286	0.271

Table 4: Orifices Output Table

Name	Inlet Node	Outlet Node	Cross-Section	Height (m)	Inlet Offset (m)	Discharge Coeff.	Max.  Flow  (L/s)	Contributing Area (ha)	Contributing Imp. Area (ha)
ICD	MHST-8_(PROP_STM)	ICDdummy	CIRCULAR	0.32	0	0.61	287.61	1.152	1.008

Table 5: Outlets Output Table

Name	Inlet Node	Outlet Node	Rating Curve	Curve Name	Max.  Flow  (L/s)	Contributing Area (ha)	Contributing Imp. Area (ha)
BLDGA	RD-BLDGA	MHST-17_(PROP_STM)	TABULAR/DEPTH	BldgA	11.56	0.158	0.158
BLDGB	RD-BLDGB	MHST-17_(PROP_STM)	TABULAR/DEPTH	BldgB	4.86	0.06	0.06
BLDGC	RD-BLDGC	MHST-6_(PROP_STM)	TABULAR/DEPTH	BldgC	6.51	0.08	0.08
BLDGD	RD-BLDGD	MHST-6_(PROP_STM)	TABULAR/DEPTH	BldgD	3.27	0.042	0.042

Table 6A: Subcatchments Output Table

Name	Rain Gage	Area (ha)	Width (m)	Flow Length (m)	Slope (%)	Imperv. (%)	N Imperv	N Perv	Dstore Imperv (mm)	Dstore Perv (mm)	Zero Imperv (%)
WS-01	Chicago3h-100y	0.157965	27.235	58.001	1.5	100	0.016	0.15	1.57	4.67	25
WS-02	Chicago3h-100y	0.059512	14.878	40	1.5	100	0.016	0.15	1.57	4.67	25
WS-03	Chicago3h-100y	0.079897	17.369	46	1.5	100	0.016	0.15	1.57	4.67	25
WS-04	Chicago3h-100y	0.041807	14.931	28	1.5	100	0.016	0.15	1.57	4.67	25
WS-05	Chicago3h-100y	0.044268	22.134	20	1.5	75	0.016	0.15	1.57	4.67	25
WS-06	Chicago3h-100y	0.106605	32.305	33	1.5	90	0.016	0.15	1.57	4.67	25
WS-07	Chicago3h-100y	0.187788	30.288	62.001	1.5	96	0.016	0.15	1.57	4.67	25
WS-08	Chicago3h-100y	0.098084	19.617	49.999	1.5	92	0.016	0.15	1.57	4.67	25
WS-09	Chicago3h-100y	0.095242	23.81	40.001	1.5	83	0.016	0.15	1.57	4.67	25
WS-10	Chicago3h-100y	0.069522	16.553	42	1.5	97	0.016	0.15	1.57	4.67	25
WS-11	Chicago3h-100y	0.022339	14.893	15	1.5	80	0.016	0.15	1.57	4.67	25
WS-12	Chicago3h-100y	0.008462	6	14.103	1.5	57	0.016	0.15	1.57	4.67	25
WS-13	Chicago3h-100y	0.012193	6.097	19.998	1.5	0	0.016	0.15	1.57	4.67	25
WS-14	Chicago3h-100y	0.028897	9.03	32.001	1.5	0	0.016	0.15	1.57	4.67	25
WS-15	Chicago3h-100y	0.128916	17	75.833	1.5	80	0.016	0.15	1.57	4.67	25
WS-16	Chicago3h-100y	0.139862	21.517	65.001	1.5	84	0.016	0.15	1.57	4.67	25
WS-17	Chicago3h-100y	0.023343	10.61	22.001	1.5	100	0.016	0.15	1.57	4.67	25



Table 6B: Subcatchments Output Table

Name	Infiltration Method	Max. Infil. Rate (mm/hr)	Min. Infil. Rate (mm/hr)	Decay Constant (1/hr)	Drying Time (days)	Peak Runoff (L/s)	Runoff Coefficient
WS-01	HORTON	76.2	13.2	4.14	7	78	0.992
WS-02	HORTON	76.2	13.2	4.14	7	29.49	0.991
WS-03	HORTON	76.2	13.2	4.14	7	39.55	0.991
WS-04	HORTON	76.2	13.2	4.14	7	20.73	0.989
WS-05	HORTON	76.2	13.2	4.14	7	21.05	0.847
WS-06	HORTON	76.2	13.2	4.14	7	52.06	0.935
WS-07	HORTON	76.2	13.2	4.14	7	92.15	0.97
WS-08	HORTON	76.2	13.2	4.14	7	47.95	0.947
WS-09	HORTON	76.2	13.2	4.14	7	45.71	0.893
WS-10	HORTON	76.2	13.2	4.14	7	34.29	0.975
WS-11	HORTON	76.2	13.2	4.14	7	10.75	0.877
WS-12	HORTON	76.2	13.2	4.14	7	3.88	0.743
WS-13	HORTON	76.2	13.2	4.14	7	3.69	0.389
WS-14	HORTON	76.2	13.2	4.14	7	6.89	0.373
WS-15	HORTON	76.2	13.2	4.14	7	59.59	0.873
WS-16	HORTON	76.2	13.2	4.14	7	66.46	0.898
WS-17	HORTON	76.2	13.2	4.14	7	11.58	0.988

Table 7: Conduits Output Table

Inlet Node	Outlet Node	Length (m)	Roughness	Outlet Offset (m)	Geom1 (m)	Slope (m/m)	Max.  Flow  (L/s)	Max.  Velocity  (m/s)	Max/Full Flow	Max/Full Depth	Contributing Area (ha)
EX_CBMH_(PROP_STM)	EX-MHST	10.2	0.013	0	0.75	0.05893	306	4.06	0.11	0.23	1.305
CHAMBERS	SC-MH-20_(PROP_STM)	1	0.013	0.7	0.3	0.03001	145.05	4.7	0.87	1	0
ICDdummy	MHST-6_(PROP_STM)	24.987	0.013	0.03	0.6	0.002	287.62	1.53	1.05	0.63	1.152
MHST-3_(PROP_STM)	MHST-8_(PROP_STM)	63.021	0.013	0.15	0.45	0.00206	180.71	1.14	1.4	1	0.443
MHST-18_(PROP_STM)	MHST-3_(PROP_STM)	51.289	0.013	0.06	0.45	0.00195	160.9	1.01	1.28	1	0.399
MHST-14_(PROP_STM)	CBMH-13_(PROP_STM)	22.461	0.013	0.15	0.25	0.02093	42.53	0.87	0.49	1	0.029
CBMH-13_(PROP_STM)	MHST-9_(PROP_STM)	26.694	0.013	0.075	0.375	0.00244	109.54	0.99	1.27	1	0.411
MHST-9_(PROP_STM)	MHST-8_(PROP_STM)	7.63	0.013	0.15	0.45	0.00262	103.18	0.77	0.71	1	0.423
MHST-10_(PROP_STM)	MHST-9_(PROP_STM)	23.848	0.013	1.083	0.25	0.01204	40.06	0.97	0.61	1	0.012
RY-CB-15_(PROP_STM)	MHST-14_(PROP_STM)	16.242	0.013	0.06	0.25	0.01971	37.4	0.95	0.45	1	0.029
MHST-6_(PROP_STM)	EX_CBMH_(PROP_STM)	4.449	0.013	0.15	0.6	0.00225	303.17	1.68	1.04	0.61	1.296
TD-LoadingDock	CBMH-16_(PROP_STM)	29.919	0.013	0.19	0.2	0.02006	31.62	1.07	0.68	1	0.023
RY-CB-11_(PROP_STM)	MHST-10_(PROP_STM)	13.878	0.013	0.062	0.25	0.02004	15.57	0.62	0.18	1	0.012
MHST-17_(PROP_STM)	CBMH-13_(PROP_STM)	30.435	0.013	0.125	0.25	0.00706	22.88	0.91	0.46	1	0.217
CBMH-16_(PROP_STM)	MHST-18_(PROP_STM)	20.251	0.013	0.08	0.375	0.00296	110.28	1.09	1.16	1	0.292
CB-19_(PROP_STM)	CBMH-16_(PROP_STM)	20	0.013	0.32	0.25	0.02	57.45	1.68	0.68	1	0.129
SC-MH-20_(PROP_STM)	MHST-8_(PROP_STM)	13.278	0.013	0.77	0.45	0.0128	161	1.8	0.5	1	0.286

# PCSWMM Report

SWM Report - 100y + 20%  
Model 3850 Cambrian Rd - SWM Model.inp

Parsons  
October 16, 2023

# Table of Contents

## Maps

Figure 1: Extent 1 .....	3
--------------------------	---

## Profiles

Figure 2: Node CB-19_(PROP_STM) to Node EX-MHST .....	4
Figure 3: Node RY-CB-15_(PROP_STM) to Node EX-MHST .....	5
Figure 4: Node CHAMBERS to Node EX-MHST .....	6
Figure 5: Node TD-LoadingDock to Node EX-MHST .....	7
Figure 6: Node RY-CB-11_(PROP_STM) to Node EX-MHST .....	8
Figure 7: Node MHST-17_(PROP_STM) to Node EX-MHST .....	9

## Tables

Table 1: Storages Table Output .....	10
Table 2: Outfalls Table Output .....	11
Table 3: Junctions Output Table .....	12
Table 4: Orifices Output Table .....	12
Table 5: Outlets Output Table .....	13
Table 6A: Subcatchments Output Table .....	13
Table 6B: Subcatchments Output Table .....	14
Table 7: Conduits Output Table .....	15



Figure 1: Extent 1

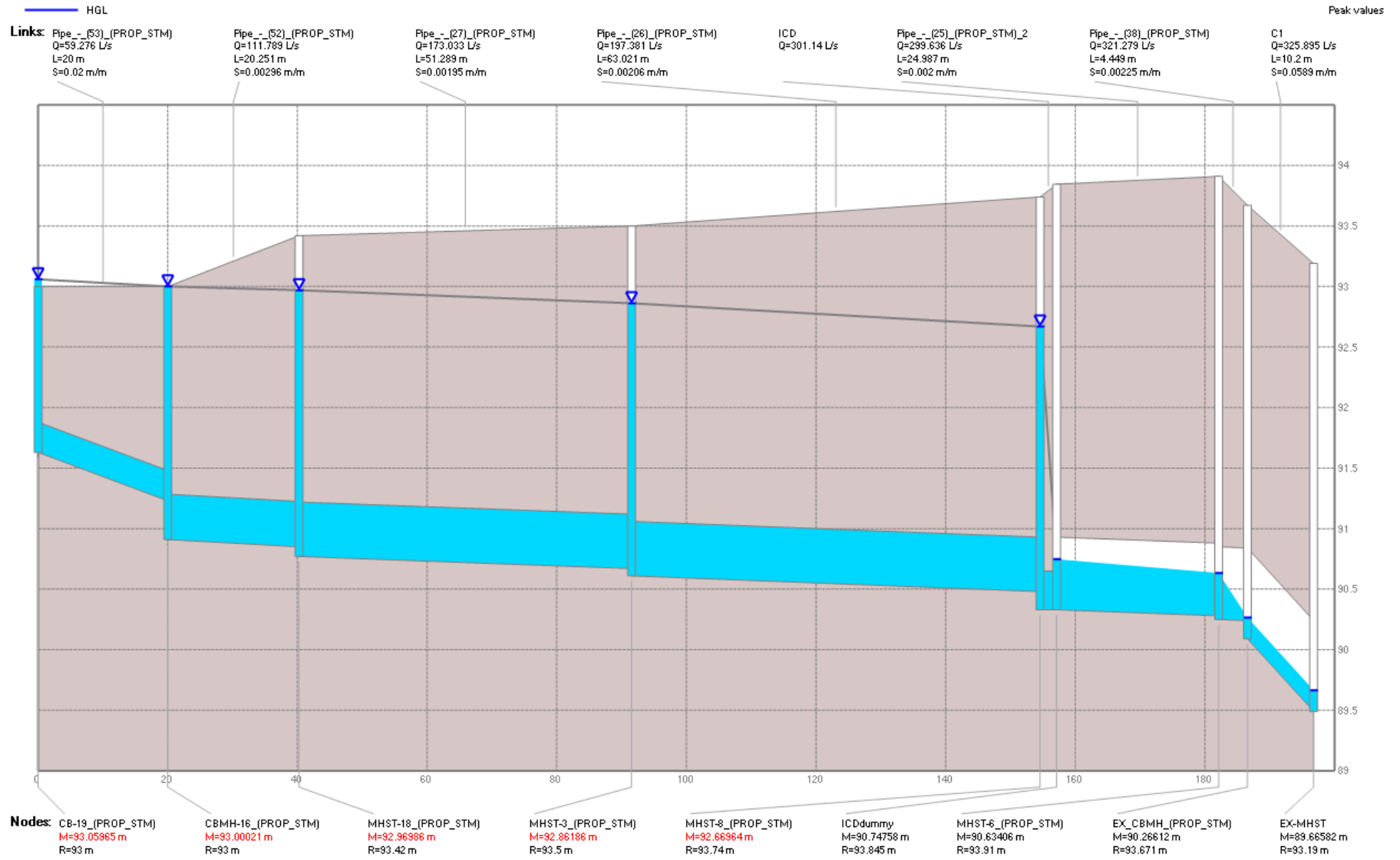

Figure 2: Node CB-19\_(PROP\_STM) to Node EX-MHST

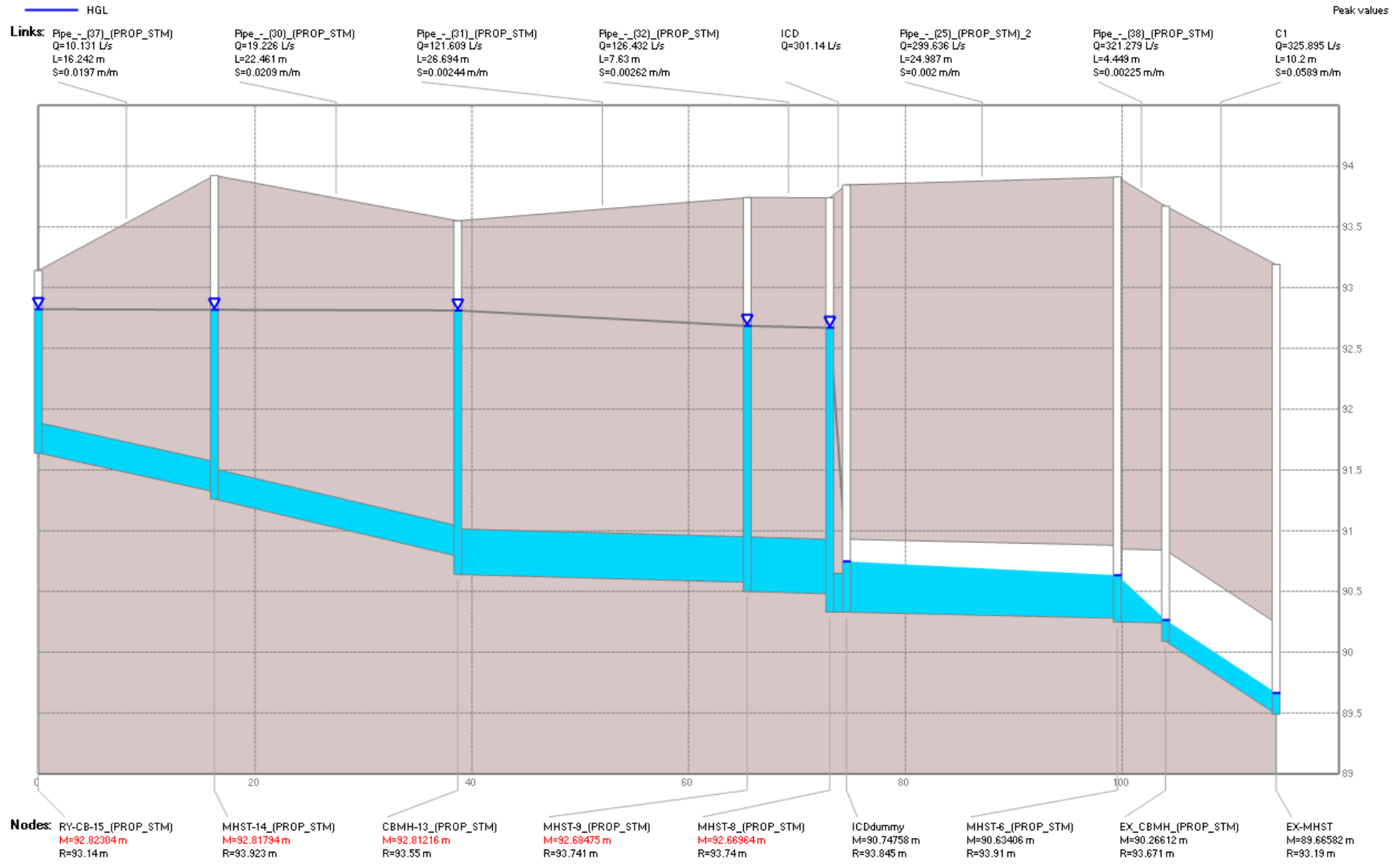

Figure 3: Node RY-CB-15\_(PROP\_STM) to Node EX-MHST

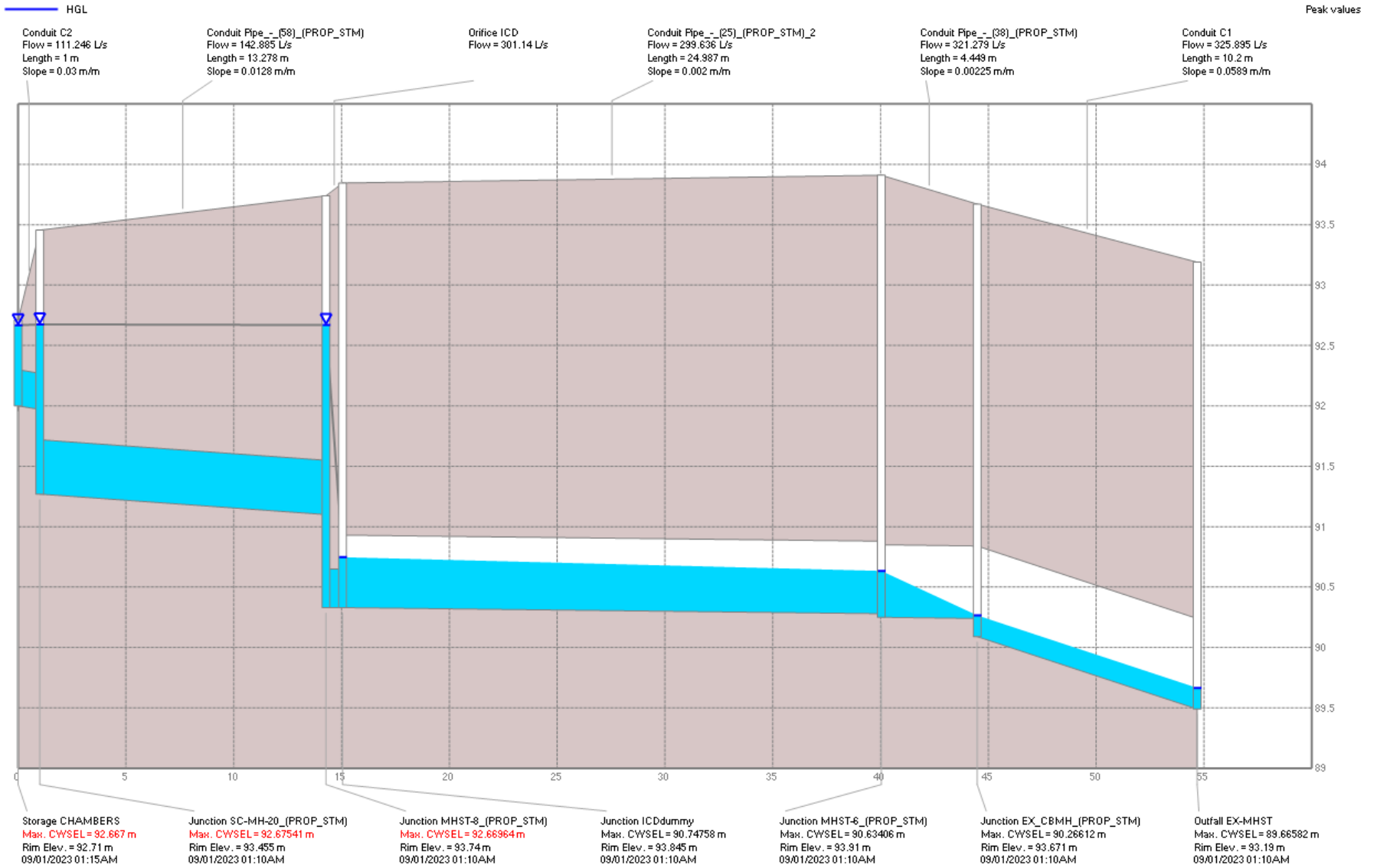

Figure 4: Node CHAMBERS to Node EX-MHST



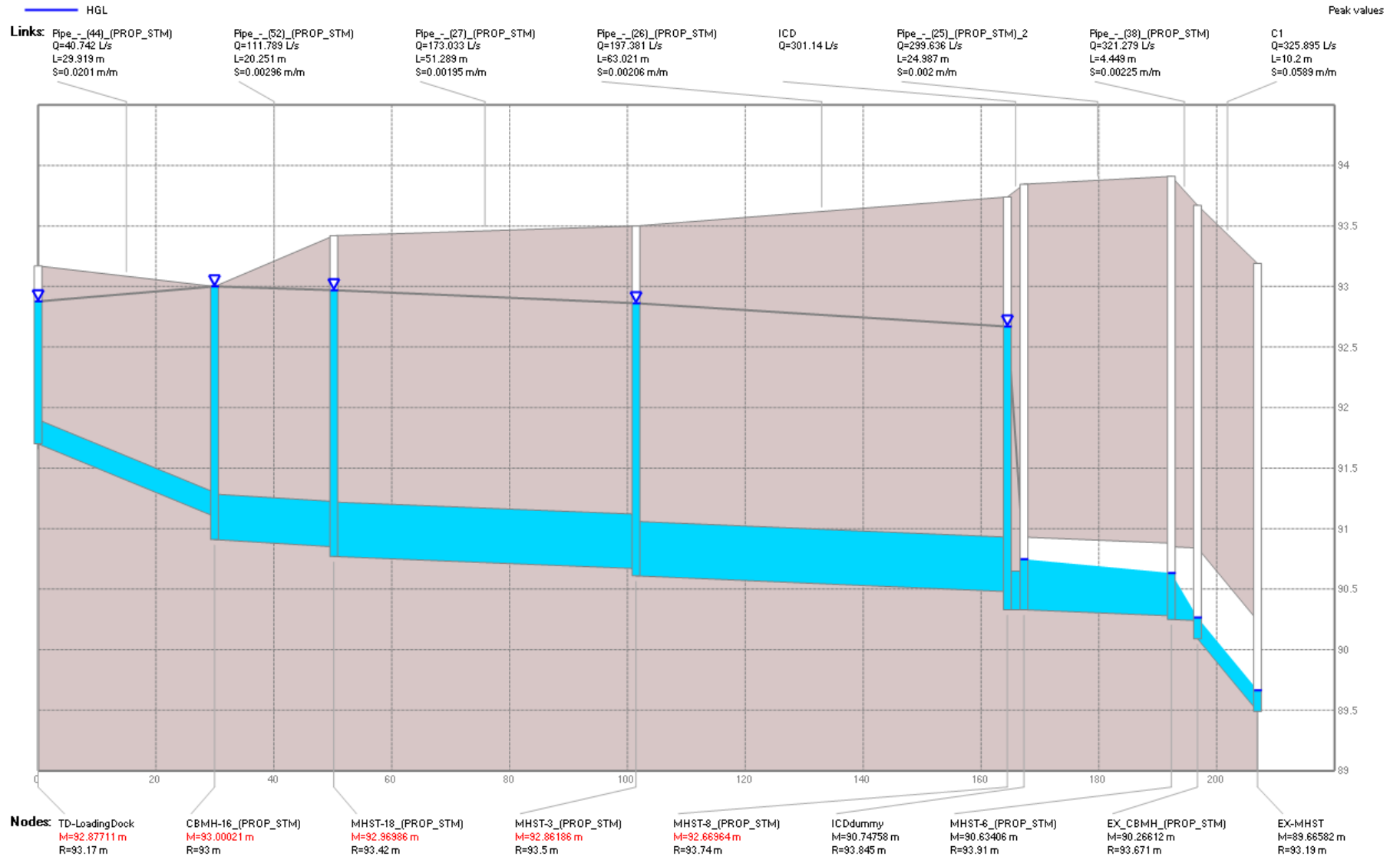

Figure 5: Node TD-LoadingDock to Node EX-MHST

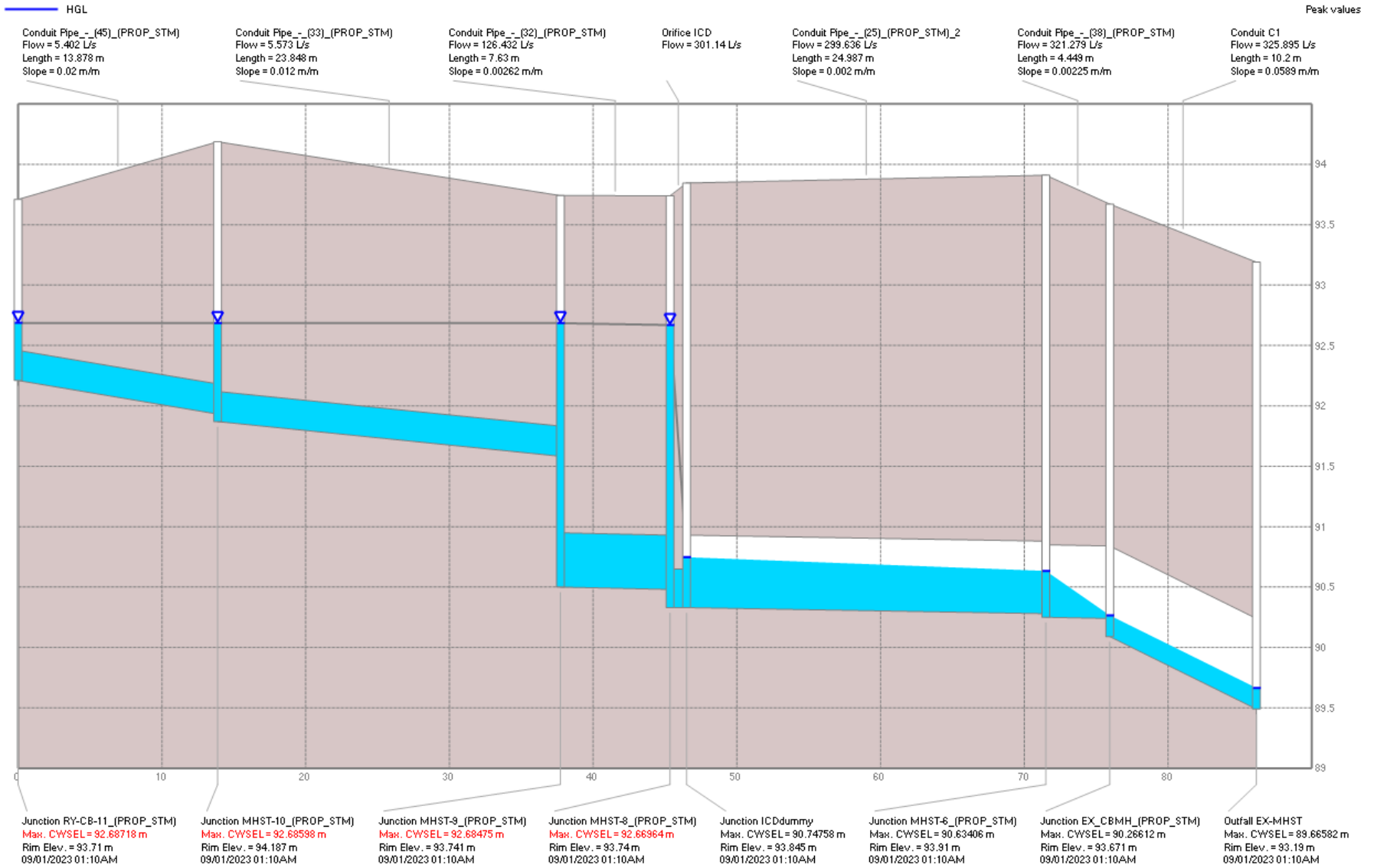

Figure 6: Node RY-CB-11\_(PROP\_STM) to Node EX-MHST

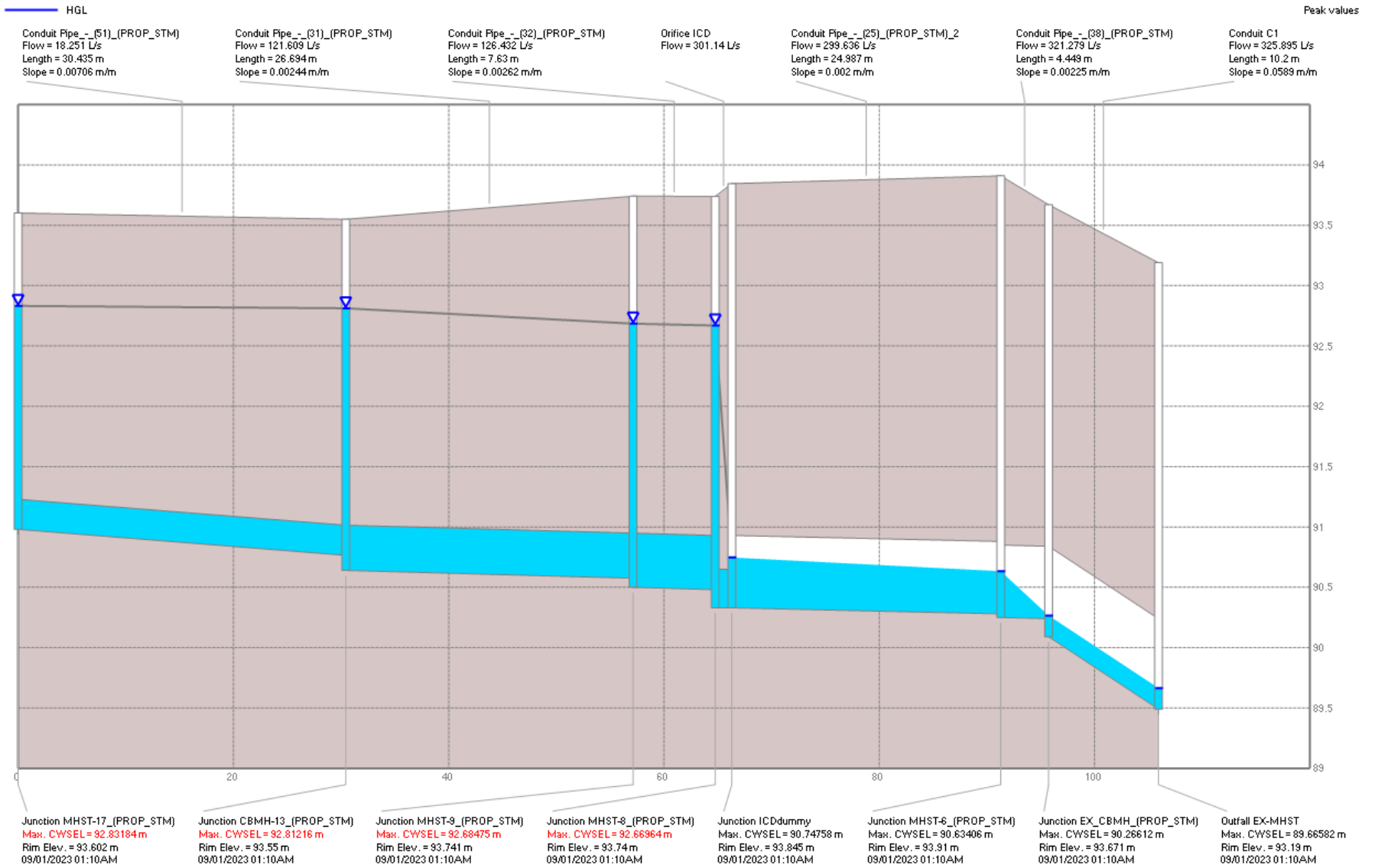

Figure 7: Node MHST-17\_(PROP\_STM) to Node EX-MHST

Table 1: Storages Table Output

Name	Invert Elev. (m)	Rim Elev. (m)	Depth (m)	Avg. Depth (m)	Max. Depth (m)	Max. Total Inflow (L/s)	Avg. Volume (1000 m³)	Avg. Percent Full (%)	Max. Volume (1000 m³)	Max. Percent Full (%)	Max. Outflow (L/s)	Contributing Area (ha)	Max. HGL (m)	Storage Curve
CHAMBERS	92	92.71	0.71	0.03	0.71	203.99	0.003	4	0.07	100	111.96	0	92.71	TABULAR
RD-BLDGA	97	97.15	0.15	0.04	0.12	93.75	0.019	16	0.077	65	12.86	0.158	97.12	TABULAR
RD-BLDGB	97	97.15	0.15	0.03	0.12	35.4	0.006	14	0.028	63	5.41	0.06	97.12	TABULAR
RD-BLDGC	97	97.15	0.15	0.03	0.12	47.5	0.008	14	0.038	63	7.25	0.08	97.12	TABULAR
RD-BLDGD	97	97.15	0.15	0.03	0.12	24.88	0.005	15	0.02	64	3.64	0.042	97.12	TABULAR
TD-LoadingDock	91.7	93.17	1.47	0.08	1.18	39.87	0.001	1	0.021	28	52.87	0.023	92.88	TABULAR

Table 2: Outfalls Table Output

Name	Invert Elev. (m)	Rim Elev. (m)	Avg. Depth (m)	Max. Depth (m)	Max. HGL (m)	Rep. Max. Depth (m)	Max. Total Inflow (L/s)	Avg. Flow (L/s)	Contributing Area (ha)	Contributing Imp. Area (ha)
EX-MHST	89.49	93.19	0.03	0.18	89.67	0.18	330.03	67.46	1.305	1.152

Table 3: Junctions Output Table

Name	Invert Elev. (m)	Rim Elev. (m)	Depth (m)	Avg. Depth (m)	Max. Depth (m)	Max. HGL (m)	Max. Total Inflow (L/s)	Max. Surcharge (m)	Max. Poned Depth (m)	Contributing Area (ha)	Contributing Imp. Area (ha)
CB-19_(PROP_STM)	91.63	93	1.37	0.08	1.44	93.07	73.07	1.191	0.071	0.129	0.103
CBMH-13_(PROP_STM)	90.64	93.55	2.91	0.17	2.2	92.84	122.16	1.801	0	0.411	0.364
CBMH-16_(PROP_STM)	90.91	93	2.09	0.14	2.09	93	132.47	1.522	0.002	0.292	0.244
EX_CBMH_(PROP_STM)	90.09	93.671	3.581	0.04	0.18	90.27	330.01	0	0	1.305	1.152
ICDdummy	90.33	93.845	3.515	0.08	0.42	90.75	304.96	0	0	1.152	1.008
MHST-10_(PROP_STM)	91.87	94.187	2.317	0.03	2.32	94.19	45.09	2.005	0	0.012	0
MHST-14_(PROP_STM)	91.26	93.923	2.663	0.08	2.12	93.38	46.89	1.812	0	0.029	0
MHST-17_(PROP_STM)	90.98	93.602	2.622	0.13	2.4	93.38	27.28	2.146	0	0.217	0.217
MHST-18_(PROP_STM)	90.77	93.42	2.65	0.16	2.2	92.97	174.13	1.748	0	0.399	0.34
MHST-3_(PROP_STM)	90.61	93.5	2.89	0.17	2.27	92.88	198.55	1.761	0	0.443	0.373
MHST-6_(PROP_STM)	90.25	93.91	3.66	0.08	0.39	90.64	325.79	0	0	1.296	1.147
MHST-8_(PROP_STM)	90.33	93.74	3.41	0.22	2.39	92.72	313.71	1.169	0	1.152	1.008
MHST-9_(PROP_STM)	90.5	93.741	3.241	0.18	2.23	92.73	126.71	0.899	0	0.423	0.364
RY-CB-11_(PROP_STM)	92.21	93.71	1.5	0.01	0.53	92.74	17.32	0.276	0	0.012	0
RY-CB-15_(PROP_STM)	91.64	93.14	1.5	0.05	1.5	93.14	44.61	1.251	0.001	0.029	0
SC-MH-20_(PROP_STM)	91.27	93.455	2.185	0.09	1.46	92.73	203.57	0.455	0	0.286	0.271

Table 4: Orifices Output Table

Name	Inlet Node	Outlet Node	Cross-Section	Height (m)	Inlet Offset (m)	Discharge Coeff.	Max.  Flow  (L/s)	Contributing Area (ha)	Contributing Imp. Area (ha)
ICD	MHST-8_(PROP_STM)	ICDdummy	CIRCULAR	0.32	0	0.61	304.96	1.152	1.008

Table 5: Outlets Output Table

Name	Inlet Node	Outlet Node	Rating Curve	Curve Name	Max.  Flow  (L/s)	Contributing Area (ha)	Contributing Imp. Area (ha)
BLDGA	RD-BLDGA	MHST-17_(PROP_STM)	TABULAR/DEPTH	BldgA	12.86	0.158	0.158
BLDGB	RD-BLDGB	MHST-17_(PROP_STM)	TABULAR/DEPTH	BldgB	5.41	0.06	0.06
BLDGC	RD-BLDGC	MHST-6_(PROP_STM)	TABULAR/DEPTH	BldgC	7.25	0.08	0.08
BLDGD	RD-BLDGD	MHST-6_(PROP_STM)	TABULAR/DEPTH	BldgD	3.64	0.042	0.042

Table 6A: Subcatchments Output Table

Name	Rain Gage	Area (ha)	Width (m)	Flow Length (m)	Slope (%)	Imperv. (%)	N Imperv	N Perv	Dstore Imperv (mm)	Dstore Perv (mm)	Zero Imperv (%)
WS-01	Chicago3h-StressTest	0.157965	27.235	58.001	1.5	100	0.016	0.15	1.57	4.67	25
WS-02	Chicago3h-StressTest	0.059512	14.878	40	1.5	100	0.016	0.15	1.57	4.67	25
WS-03	Chicago3h-StressTest	0.079897	17.369	46	1.5	100	0.016	0.15	1.57	4.67	25
WS-04	Chicago3h-StressTest	0.041807	14.931	28	1.5	100	0.016	0.15	1.57	4.67	25
WS-05	Chicago3h-StressTest	0.044268	22.134	20	1.5	75	0.016	0.15	1.57	4.67	25
WS-06	Chicago3h-StressTest	0.106605	32.305	33	1.5	90	0.016	0.15	1.57	4.67	25
WS-07	Chicago3h-StressTest	0.187788	30.288	62.001	1.5	96	0.016	0.15	1.57	4.67	25
WS-08	Chicago3h-StressTest	0.098084	19.617	49.999	1.5	92	0.016	0.15	1.57	4.67	25
WS-09	Chicago3h-StressTest	0.095242	23.81	40.001	1.5	83	0.016	0.15	1.57	4.67	25
WS-10	Chicago3h-StressTest	0.069522	16.553	42	1.5	97	0.016	0.15	1.57	4.67	25
WS-11	Chicago3h-StressTest	0.022339	14.893	15	1.5	80	0.016	0.15	1.57	4.67	25
WS-12	Chicago3h-StressTest	0.008462	6	14.103	1.5	57	0.016	0.15	1.57	4.67	25
WS-13	Chicago3h-StressTest	0.012193	6.097	19.998	1.5	0	0.016	0.15	1.57	4.67	25
WS-14	Chicago3h-StressTest	0.028897	9.03	32.001	1.5	0	0.016	0.15	1.57	4.67	25
WS-15	Chicago3h-StressTest	0.128916	17	75.833	1.5	80	0.016	0.15	1.57	4.67	25
WS-16	Chicago3h-StressTest	0.139862	21.517	65.001	1.5	84	0.016	0.15	1.57	4.67	25
WS-17	Chicago3h-StressTest	0.023343	10.61	22.001	1.5	100	0.016	0.15	1.57	4.67	25

Table 6B: Subcatchments Output Table

Name	Infiltration Method	Max. Infil. Rate (mm/hr)	Min. Infil. Rate (mm/hr)	Decay Constant (1/hr)	Drying Time (days)	Peak Runoff (L/s)	Runoff Coefficient
WS-01	HORTON	76.2	13.2	4.14	7	93.75	0.994
WS-02	HORTON	76.2	13.2	4.14	7	35.4	0.993
WS-03	HORTON	76.2	13.2	4.14	7	47.5	0.994
WS-04	HORTON	76.2	13.2	4.14	7	24.88	0.992
WS-05	HORTON	76.2	13.2	4.14	7	25.55	0.867
WS-06	HORTON	76.2	13.2	4.14	7	62.71	0.943
WS-07	HORTON	76.2	13.2	4.14	7	110.92	0.975
WS-08	HORTON	76.2	13.2	4.14	7	57.77	0.954
WS-09	HORTON	76.2	13.2	4.14	7	55.4	0.908
WS-10	HORTON	76.2	13.2	4.14	7	41.21	0.979
WS-11	HORTON	76.2	13.2	4.14	7	12.99	0.892
WS-12	HORTON	76.2	13.2	4.14	7	4.76	0.777
WS-13	HORTON	76.2	13.2	4.14	7	5.2	0.468
WS-14	HORTON	76.2	13.2	4.14	7	10.17	0.455
WS-15	HORTON	76.2	13.2	4.14	7	73.07	0.891
WS-16	HORTON	76.2	13.2	4.14	7	80.85	0.913
WS-17	HORTON	76.2	13.2	4.14	7	13.89	0.991



Table 7: Conduits Output Table

Inlet Node	Outlet Node	Length (m)	Roughness	Outlet Offset (m)	Geom1 (m)	Slope (m/m)	Max.  Flow  (L/s)	Max.  Velocity  (m/s)	Max/Full Flow	Max/Full Depth	Contributing Area (ha)
EX_CBMH_(PROP_STM)	EX-MHST	10.2	0.013	0	0.75	0.05893	330.03	4.14	0.12	0.24	1.305
CHAMBERS	SC-MH-20_(PROP_STM)	1	0.013	0.7	0.3	0.03001	203.99	5.19	1.22	1	0
ICDdummy	MHST-6_(PROP_STM)	24.987	0.013	0.03	0.6	0.002	305.04	1.57	1.11	0.65	1.152
MHST-3_(PROP_STM)	MHST-8_(PROP_STM)	63.021	0.013	0.15	0.45	0.00206	198.54	1.25	1.53	1	0.443
MHST-18_(PROP_STM)	MHST-3_(PROP_STM)	51.289	0.013	0.06	0.45	0.00195	174.12	1.09	1.38	1	0.399
MHST-14_(PROP_STM)	CBMH-13_(PROP_STM)	22.461	0.013	0.15	0.25	0.02093	44.09	0.9	0.51	1	0.029
CBMH-13_(PROP_STM)	MHST-9_(PROP_STM)	26.694	0.013	0.075	0.375	0.00244	122.11	1.11	1.41	1	0.411
MHST-9_(PROP_STM)	MHST-8_(PROP_STM)	7.63	0.013	0.15	0.45	0.00262	126.63	0.8	0.87	1	0.423
MHST-10_(PROP_STM)	MHST-9_(PROP_STM)	23.848	0.013	1.083	0.25	0.01204	43.18	1.05	0.66	1	0.012
RY-CB-15_(PROP_STM)	MHST-14_(PROP_STM)	16.242	0.013	0.06	0.25	0.01971	41.54	0.87	0.5	1	0.029
MHST-6_(PROP_STM)	EX_CBMH_(PROP_STM)	4.449	0.013	0.15	0.6	0.00225	325.81	1.73	1.12	0.63	1.296
TD-LoadingDock	CBMH-16_(PROP_STM)	29.919	0.013	0.19	0.2	0.02006	52.87	1.68	1.14	1	0.023
RY-CB-11_(PROP_STM)	MHST-10_(PROP_STM)	13.878	0.013	0.062	0.25	0.02004	15.2	0.69	0.18	1	0.012
MHST-17_(PROP_STM)	CBMH-13_(PROP_STM)	30.435	0.013	0.125	0.25	0.00706	23.96	0.94	0.48	1	0.217
CBMH-16_(PROP_STM)	MHST-18_(PROP_STM)	20.251	0.013	0.08	0.375	0.00296	112.75	1.11	1.18	1	0.292
CB-19_(PROP_STM)	CBMH-16_(PROP_STM)	20	0.013	0.32	0.25	0.02	63.56	1.7	0.76	1	0.129
SC-MH-20_(PROP_STM)	MHST-8_(PROP_STM)	13.278	0.013	0.77	0.45	0.0128	142.94	1.81	0.44	1	0.286

## DRAWINGS

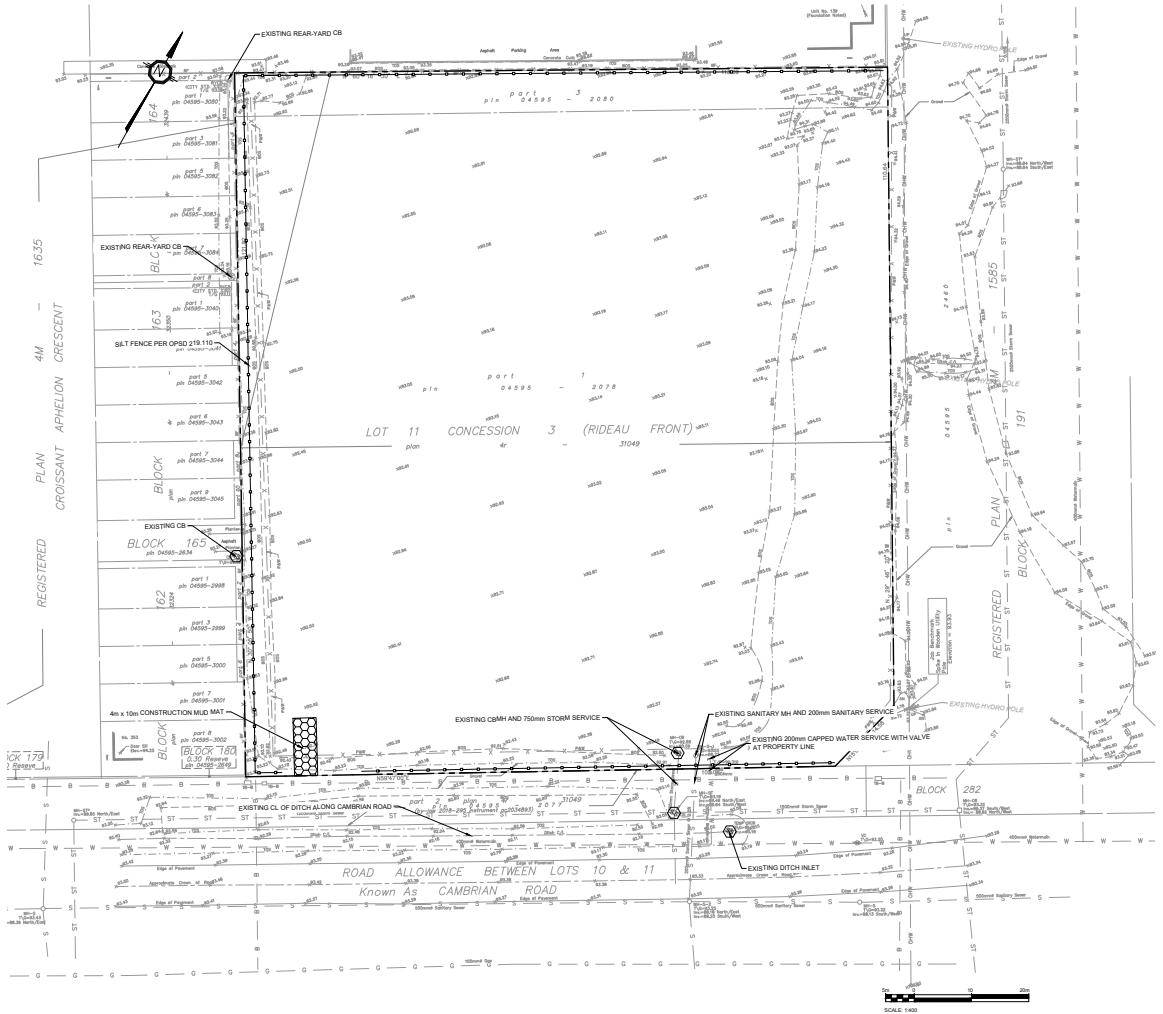

**LEGEND:**

- EXISTING PROPERTY LINE
- W W W EXISTING WATERMAIN
- V EXISTING VALVE
- S S S EXISTING SANITARY SEWER AND MAINTENANCE HOLE
- ST ST ST EXISTING STORM SEWER AND MAINTENANCE HOLE
- EXISTING GRADE
- OH OH EXISTING OVERHEAD HYDRO
- G EXISTING GAS
- B B B EXISTING BELL
- 4m x 10m CONSTRUCTION MUD MAT
- PROPOSED SILT FENCE AS PER OPSD 219.110
- SILT SACK PER DETAIL D1

**EROSION AND SEDIMENT CONTROL MEASURES:**

- CONTRACTOR IS RESPONSIBLE FOR ALL INSTALLATION, MONITORING, REPAIR AND REMOVAL OF ALL EROSION AND SEDIMENT CONTROL FEATURES. THE CONTRACTOR SHALL IMPLEMENT BEST MANAGEMENT PRACTICES TO PREVENT PROTECTION OF THE AREA DRAINAGE SYSTEM AND THE RECEIVING WATERBODIES DURING CONSTRUCTION ACTIVITIES. THE CONTRACTOR ACKNOWLEDGES THAT FAILURE TO IMPLEMENT APPROPRIATE EROSION AND SEDIMENT CONTROL MEASURES MAY BE SUBJECT TO PENALTIES IMPOSED BY ANY APPLICABLE REGULATORY AGENCY.
- SEDIMENT AND EROSION CONTROL IS AN OBJECTIVE.
- PREVENT SOIL EROSION. THIS CAN RESULT FROM STREAMING RAIN WATER OR WIND EROSION DURING CONSTRUCTION.
- PREVENT SEDIMENT DEPOSIT IN THE RECEIVING AND RECEIVING COLLECTING STREAMS (AS APPLICABLE).
- PREVENT AIR POLLUTION FROM PARTICULATE MATTER AND DUST.

**PRIOR TO START OF CONSTRUCTION:**

PRIOR TO THE REMOVAL OF ANY VEGETATIVE COVER MOVING OF SOIL AND CONSTRUCTION:

- INSTALL SILT FENCE AS PER OPSD 219.110 ALONG EXPOSED IMMEDIATELY DOWNSTREAM FROM AREAS TO BE EXPOSED FOR CONSTRUCTION.
- INSTALL FILTER CLOTH ON DOWNSTREAM MANHOLE COVERS.
- REPAIR SILT FENCES IMMEDIATELY UPON DAMAGE TO STRUCTURES.
- INSPECT MEASURES IMMEDIATELY AFTER INSTALLATION.
- THE CONTRACTOR MUST SET UP THE MEASURES INDICATED ON THE PLAN. INSPECT THEM FREQUENTLY AND CLEAN AND REPAIR OR REPLACE THE SEDIMENTATION STRUCTURES AT THE END OF THE CONSTRUCTION PERIOD. THE CONTRACTOR IS RESPONSIBLE FOR REMOVAL OF THE TEMPORARY STRUCTURES AND RECONSTRUCTING THE AFFECTED AREAS.

**2 DURING CONSTRUCTION:**

- SEDIMENT AND EROSION CONTROL MEASURES TO BE CONSTRUCTED AS PER OPSD 219.110.
- WHERE SEDIMENT AND EROSION CONTROL MEASURES MUST BE REMOVED TO COMPLETE A PORTION OF THE WORK, THE SAME MEASURES MUST BE REINSTALLED BEFORE THE WORKS COMPLETION.
- WORK TO BE DONE IN THE VICINITY OF MANHOLE REVISIONS TO BE COMPLETED FROM JULY AND SEPTEMBER ONLY.
- MINIMIZE THE EXTENT OF DISTURBED AREAS AND THE ELEVATION OF EROSION.
- PROTECT DISTURBED AREAS FROM RAINWATER.
- PROVIDE TEMPORARY COVER SUCH AS SEEDING OR MULCHING IF DISTURBED AREA WILL NOT BE RECLAIMED IMMEDIATELY.
- INSPECT STRAW BALE FLOW CHECK DAMS, SILT FENCES, SILT SACKS AND CATCH BASIN SUMPS REGULARLY AND REPAIR OR REPLACE AS REQUIRED.
- PLAN TO BE REVERSED AND REVISED AS REQUIRED DURING CONSTRUCTION.
- DO NOT EXPOSE TOPSOIL, FILL OR SEDIMENT MATERIALS UNLESS THEY ARE FROM AN EXPOSED SURFACE OR ON WHICH IT IS TO BE PLACED BEFORE THE PILE IS REMOVED. ALL TOPSOIL PILES ARE TO BE COVERED IF THEY ARE TO REMAIN ON SITE (OR PILES FOR EXPORT TO OTHER LOCATIONS) FOR MORE THAN 30 DAYS. WHEN STORING SOIL ON SITE THE CONTRACTOR MUST COVER EACH PILE WITH TARPERS, STRAW OR A GEOTEXTILE FABRIC TO AVOID PARTICLE TRANSPORT BY WIND OR WATER TRANSDRUMS AND WATER CONTROL. WIND-BLOWN DUST OFF SITE TO ADJACENT AREAS BY SEEDING TOPSOIL PILES AND OTHER AREAS TEMPORARILY EXPOSURE MATERIALS AS REQUIRED. FOR DUST CONTROL, CONTRACTOR TO APPLY LACALUM OR SIMILAR TYPE 1 TYPE 2500 GRAIN/TON AND WATER WITH EQUIPMENT APPROVED BY THE OWNER'S REPRESENTATIVE AT RATE IN ACCORDANCE TO OPSD 219.110 WHEN DIRECTED BY OWNER'S REPRESENTATIVE.
- ALL EROSION CONTROL STRUCTURE TO REMAIN IN PLACE UNTIL ALL DISTURBED GROUND SURFACES HAVE BEEN STABILIZED BY PLANTING OR RESEEDING OF RESIDUAL GROUND COVER. SEDIMENT CONTROL RESPONSIBLE FOR MAINTAINING, REPAIRING AND DEMOLITION TO BE CLEANED OF ALL SEDIMENT.
- NO TOXIC MATERIALS OR METHODS OF EROSION PROTECTION SHALL BE PERMITTED UNLESS APPROVED BY THE CONTRACTING ENGINEER AND THE TOWN DEPARTMENT OF PUBLIC WORKS.
- CONTRACTOR RESPONSIBLE FOR MAINTAINING, REPAIRING AND DEMOLITION TO BE CLEANED OF ALL SEDIMENT FROM AREAS INVOLVED IN THE CONSTRUCTION WORK.
- DURING THE CONSTRUCTION PERIOD, ALL UNDESIRABLE MATERIAL LEAVING THE SITE ARE TO BE SCRAPED.
- ALL EXCESS MATERIALS, INCLUDING EXCESS TOPSOIL, SHALL BE CLEANED OFF THE SITE AND EITHER REUSED OR DISPOSED.
- TIME ALL NECESSARY STEPS TO PREVENT BUILDING MATERIAL, CONSTRUCTION DEBRIS OR WASTE BEING TRUCKED OR DRAGGED WITH UNFITTING DEVICES OR TRAILERS ALONG STREETS DURING CONSTRUCTION AND PROCEED IMMEDIATELY TO CLEAN UP ANY AREAS SO AFFECTED.
- PROTECT EXISTING ENTRANCE THROUGH COURTYARDS BY THE USE OF CURBS AND TRACKING GRIDS. FINISHED SURFACES, GRAVEL BED SHALL BE A MINIMUM OF 150mm HIGH AND 150mm DEEP AND SHALL CONSIST OF CONCRETE MATERIAL. MANHOLE GRATES ENTRANCE IN CLEAN CONDITION.

**3 AFTER CONSTRUCTION:**

- PROVIDE PERMANENT COVER CONSISTING OF TOPSOIL AND SEED TO DISTURBED AREAS.
- ALL REMAINING EROSION CONTROL MEASURES TO BE REMOVED IMMEDIATELY UPON COMPLETION OF WORK AND AFTER DISTURBED AREAS HAVE BEEN REHABILITATED AND STABILIZED. THIS INCLUDES REMOVAL OF STRAW BALE FLOW CHECK DAMS, SILT FENCES AND FILTER CLOTHS ON CATCH BASINS AND MANHOLE COVERS.
- INSPECT AND CLEAN CATCH BASINS, SUMPS AND STORM SEWERS.

**TURNER FLEISCHER**  
Turner Fleischer Architects Inc.  
67 Leslie Road  
Toronto, ON M8Z 2T4  
T 416 425 2222  
turnerfleischer.com

The Planning, as an instrument of service, is provided to and for the property of Turner Fleischer Architects Inc. The drawings are the property of Turner Fleischer Architects Inc. and shall remain the property of Turner Fleischer Architects Inc. If any questions arise regarding the drawings, the drawings shall be referred to the architect. The architect is not responsible for the accuracy or completeness of the information provided by the client. The architect is not responsible for the accuracy or completeness of the information provided by the client. The architect is not responsible for the accuracy or completeness of the information provided by the client. The architect is not responsible for the accuracy or completeness of the information provided by the client.

**PARSONS**  
1800 MONROE STREET, SUITE 100, OTTAWA, ONTARIO K1J 8H9  
Tel: 613 736 8100

**TOPOGRAPHIC INFORMATION & BENCHMARK**  
SURVEY COMPLETED BY ANNE OSULLIVAN VOLLEBERG LTD. ON OCTOBER 21, 2022. ELEVATIONS SHOWN ARE GEODETIC AND ARE REFERRED TO THE CANADIAN GEODETIC DATUM DERIVED FROM CONTROL MONUMENT NO. 019688(01) HAVING AN ELEVATION OF 69.742m.

PROJECT NO.	3850 CAMBRIAN RD
PROJECT DATE	2022-08-19
DESIGNED BY	BY
CHECKED BY	MT
SCALE	As Indicated

**Choice Properties**

**PROJECT:** 3850 CAMBRIAN RD  
BARRHAVEN, ONTARIO

**DRAWING:** EROSION/SEDIMENT CONTROL & EXISTING CONDITIONS PLAN

PROJECT NO.	478256
PROJECT DATE	2022-08-19
DESIGNED BY	BY
CHECKED BY	MT
SCALE	As Indicated

APPROVED BY: [Signature]

**C101**

REGISTERED PLAN CROSSANT APHELION CRESCENT 4M 1635

REGISTERED PLAN AT PROPERTY LINE

OK 179

SCALE: 1:400

MBSA 001732-0009

### TOPOGRAPHIC INFORMATION & BENCHMARK

SURVEY COMPLETED BY ANNIS, OUSILAVAN, VOLLEBERG LTD. ON OCTOBER 21, 2022. ELEVATIONS SHOWN ARE GEODETIC AND ARE REFERRED TO THE GVD05 GEODETIC DATUM. SURVEYED FROM CONTROL MONUMENT NO. 51988070 HAVING AN ELEVATION OF 99.742m.

### NOTES - WATERMAN

- ALL WATERMAN TO BE INSTALLED AT MINIMUM COVER OF 2.4m BELOW FINISHED GRADE. WHERE THE MINIMUM COVER OF 2.4m IS NOT REACHED, THERMAL INSULATION IS REQUIRED AS PER CITY OF OTTAWA DETAIL W22.
- WATERMAN PIPE MATERIAL TO BE CLASS PVC DR-18 OR APPROVED EQUIVALENT UNLESS INDICATED OTHERWISE.
- WATERMAN TO BE CONTROLLED AS PER OPS 441 AND OPS 802.010. WATERMAN BEDDING AND COVER MATERIAL TO BE OPS 110 GRANULAR 'A' CRUSHER-RUN LIMESTONE COMPACTED TO 95% S.D.
- A CONTINUOUS 12 GAUGE COPPER TRACER WIRE MUST BE INSTALLED OVER ALL WATERMANS. TRACER WIRE SHALL BE TIED TO ALL FIRE HYDRANTS.
- INSTALLATION OF WATERMAN PIPE CROSSING A SEWER PIPE SHALL BE AS PER CITY OF OTTAWA DETAIL W22.
- IF WATERMAN PIPE MUST BE DEFLECTED TO MEET ALIGNMENT, ENSURE THAT THE AMOUNT OF DEFLECTION IS LESS THAN HALF THAT RECOMMENDED BY THE MANUFACTURER.
- CATHODIC PROTECTION REQUIRED FOR ALL RIVETTINGS AS PER OPS 1100.111.
- THRUST BLOCKS AND RESTRAINTS AS PER OPS 1103.910 AND OPS 1103.910.0.
- HYDRANT INSTALLATION SHALL BE AS PER OPS 441 AND OPS 441.1. HYDRANT TO COMPLY WITH AWWA C502.
- HYDRANTS MUST HAVE THREE EXITS (TWO 65 mm AND ONE 100 mm) OF STAINLESS STEEL WITHOUT DRAIN. FIRE HYDRANTS MUST BE INSTALLED SUCH THAT THE STROKE FORCE POINTS TOWARDS THE BIRKMANWAY FLANGE IS LOCATED ABOVE THE FINISHED GROUND APPROPRIATE TO BE 150 mm ABOVE FINISHED GROUND. FIRE FLOW TESTS FOLLOWED BY COLOUR CODING OF HYDRANTS (AS PER OPS 441) SHALL BE CARRIED OUT PRIOR TO SUBSTANTIAL COMPLETION OF THE WORK.
- WATERMAN AND HYDRANT CONTROL VALVES IN THE 100 - 300 mm RANGE WILL BE RESILIENT SEATING GATE VALVES (AWWA C509) WITH MECHANICAL JOINT CONNECTIONS. VALVES WILL REQUIRE COUPLERS TO BE USED WITH A NON-RISING STEM. VALVES WILL BE COMPLETE WITH THE STANDARD AWWA 50 mm OPERATING HANDLE TO BE INSTALLED AS PER OPS 441.
- PIPE FITTINGS (BENDES, TEES, CROSSERS, REDUCERS, ETC.) WILL BE MECHANICAL JOINT (AWWA C111) WITH CONCRETE MORTAR LINGS (AWWA C108).
- COUPLERS MUST BE COMPRESSION TYPE WITH MINIMUM PRESSURE RATING OF 1035 PSI. COUPLERS SHALL BE MELLER 11-2000.
- VALVE BOXES MUST BE COMPLETE (FLAT METALLIC) PIECE SLIDING TYPE WITH GUIDE PLATES.
- WATERMANS MUST BE THOROUGHLY FLUSHED AND CLEANED TO REMOVE ALL DIRT AND DEBRIS PRIOR TO THE DISINFECTION PROCESS.
- ALL WATERMANS SHALL BE HYDROLOGICALLY AND BACTERIOLOGICALLY TESTED AS PER PROVINCIAL AND MUNICIPAL REGULATIONS. IT IS THE CONTRACTOR'S RESPONSIBILITY TO ENSURE THAT ALL REGULATIONS ARE FOLLOWED.
- THE DISINFECTION PROCEDURE WHICH FOLLOWS INITIAL FLUSHING AND CLEANING CONSISTS OF CHLORINATION, FLASK FLUSHING AND BACTERIOLOGICAL TESTING. DISINFECTION MUST BE PERFORMED BY THE CONTRACTOR USING METHODS APPROVED BY THE CITY AND IN ACCORDANCE WITH MINISTRY OF ENVIRONMENT AND CLIMATE CHANGE GUIDELINES. DOSEAGE MUST BE 100 ppm WITH A MINIMUM RESIDUAL OF 25ppm AFTER 24 HOURS. DISINFECTANT MUST BE SUPPLIED BY THE CONTRACTOR AND MUST BE ANSI APPROVED. TESTING AND TEST RESULTS MUST BE WITNESSED BY CITY PERSONNEL.
- ALL DISINFECTANT WATER IS TO BE REMOVED FROM THE NEW WATERMANS AND REPLACED WITH DISTRIBUTION SYSTEM WATER PRIOR TO PRESSURE TESTING OF THE WATERMAN.
- PRESSURE TESTING OF ALL WATERMANS AND APPURTENANCES INSTALLED BY THE CONTRACTOR MUST BE PERFORMED BY THE CONTRACTOR USING METHODS MEETING THE APPROVAL OF THE CITY. TESTING AND RESULTS MUST BE WITNESSED BY CITY PERSONNEL.
- MANNS AND SERVICES MUST BE PRESSURE TESTED AT 1035 kPa (150 mm) IN ACCORDANCE WITH AWWA C402-02 (MINIMUM REQUIREMENT).
- LEAKAGE TESTS MUST BE CONDUCTED AS PER AWWA C402-02 (MINIMUM REQUIREMENT).
- ONCE THE DISINFECTION AND PRESSURE TESTING RESULTS HAVE BEEN APPROVED, THE CONTRACTOR MUST ENSURE THAT ALL WATERMAN PIPES ARE FLUSHED UNTIL THE CHLORINE LEVEL IN THE WATER IS SIMILAR TO THE LEVEL OF CHLORINE IN THE MUNICIPAL WATER NETWORK IN THE AREA.
- BACTERIOLOGICAL TESTING MUST CONSIST OF TWO SAMPLES TWENTY FOUR HOURS APART. IF BACTERIOLOGICAL SAMPLES ARE SATISFACTORY THE WATERMAN MAY BE PLACED ON LINE.
- ALL WATERMAN VALVES TO BE OPERATED BY THE CITY OF OTTAWA ONLY.

### NOTES - SEWER

- CONTRACTOR TO CONFIRM ELEVATION OF EXISTING STORM AND SANITARY SEWERS AT PROPOSED CONNECTION POINTS AND REPORT ANY DISCREPANCIES TO THE ENGINEER BEFORE COMMENCING ANY WORK.
- ALL WORK SHALL BE PERFORMED, AS APPLICABLE IN ACCORDANCE WITH OPS 407, 408 AND 414.
- ALL STORM AND SANITARY SEWERS INSTALLED BELOW THE GROUNDWATER TABLE ELEVATION (92.00m) SHALL BE WATER TIGHT AND INFILTRATION TESTS SHALL BE CARRIED OUT ACCORDING TO OPS MINN 415.
- CLAY HEADS SHALL BE ACCORDING CITY OF OTTAWA STD DETAIL S8 AND EXTENDED AT LEAST 15cm ABOVE THE GROUNDWATER TABLE ELEVATION.
- PIPE MATERIAL TO BE PVC DR-35 AND CONFORMED TO OPS 184, UNLESS INDICATED OTHERWISE. PIPE ENDS TO BE INSTALLED PER OPS 802.010 (MODIFIED). BEDDING AND COVER MATERIALS TO BE OPS 110 GRANULAR 'A' CRUSHER-RUN LIMESTONE BEDDING COMPACTED TO 95% S.D.
- ALL SEWERS WITH LESS THAN 1.5 METERS OF COVER ARE SUBJECTED TO INSULATION PER CITY OF OTTAWA STD DETAIL S35.
- PIPE BACKFILL MATERIAL TO BE APPROVED NATIVE MATERIAL OR SELECT SUBSTITUTIONAL MATERIAL IN COMPLIANCE WITH OPS 212.
- ALL MAINTENANCE HOLES AND CATCH BASIN MAINTENANCE HOLES TO BE 1200mm AS PER OPS 701.010 UNLESS INDICATED OTHERWISE. MAINTENANCE HOLES AND CATCH BASIN MAINTENANCE HOLES TO BE INSTALLED PER OPS 407.
- ALL CATCH BASINS TO BE BIRKMANWAY AS PER OPS 716. UNLESS INDICATED OTHERWISE, CATCH BASINS TO BE INSTALLED PER OPS 407.
- EDUCATING, BACKFILLING AND COMPACTING REQUIRED FOR MAINTENANCE HOLES, CATCH BASIN MAINTENANCE HOLES, AND CATCH BASINS TO BE COMPLETED AS PER OPS 412. THEY ARE TO BE BACKFILLED WITH OPS GRANULAR 'A' COMPACTED TO 95% S.D. JOINTS BETWEEN SECTIONS TO BE WRAPPED WITH NON-WOVEN GEOTEXTILE.
- FOR SANITARY STRUCTURES: CAST IRON CATCH BASIN MAINTENANCE HOLE COVER AS PER OPS 412.010 TYPE 'A'.
- FOR STORM STRUCTURES: CAST IRON CATCH BASIN MAINTENANCE HOLE COVER AS PER OPS 412.010 TYPE 'B' AND CAST IRON CATCH BASIN COVER AS PER OPS 412.010.
- SANITARY MAINTENANCE HOLES REQUIRE BEDDING AS PER OPS 701.021.
- THE CONTRACTOR IS RESPONSIBLE FOR MARKING OR ARRANGING ALL CONNECTIONS TO THE EXISTING SEWERS AS PER MUNICIPAL REQUIREMENTS. PRIOR TO CONNECTION, THE CONTRACTOR MUST PROVIDE, TO THE CONSULTANT, ENGINEER AND THE CITY FOR APPROVAL, ALL TEST RESULTS PERFORMED ON THE INTERNAL SERVICES.
- ADVISE THE CITY PUBLIC WORKS AT LEAST 72 HOURS IN ADVANCE BEFORE ANY CONNECTION TO THE CITY SERVICES. CO-ORDINATE WITH CITY AS REQUIRED. TERMINATE AND PLUG ALL SERVICE CONNECTIONS AT 1.0 m FROM EDGE OF THE BUILDING.
- ALL SEWERS TO BE C.T.V. INSPECTED BY THE CONTRACTOR AS PER OPS 409. TWO COPIES OF THE INSPECTION REPORT MUST BE PROVIDED TO THE CONSULTANT AND THE C.C.T.V. INSPECTION IN DVD FORMAT ONLY.

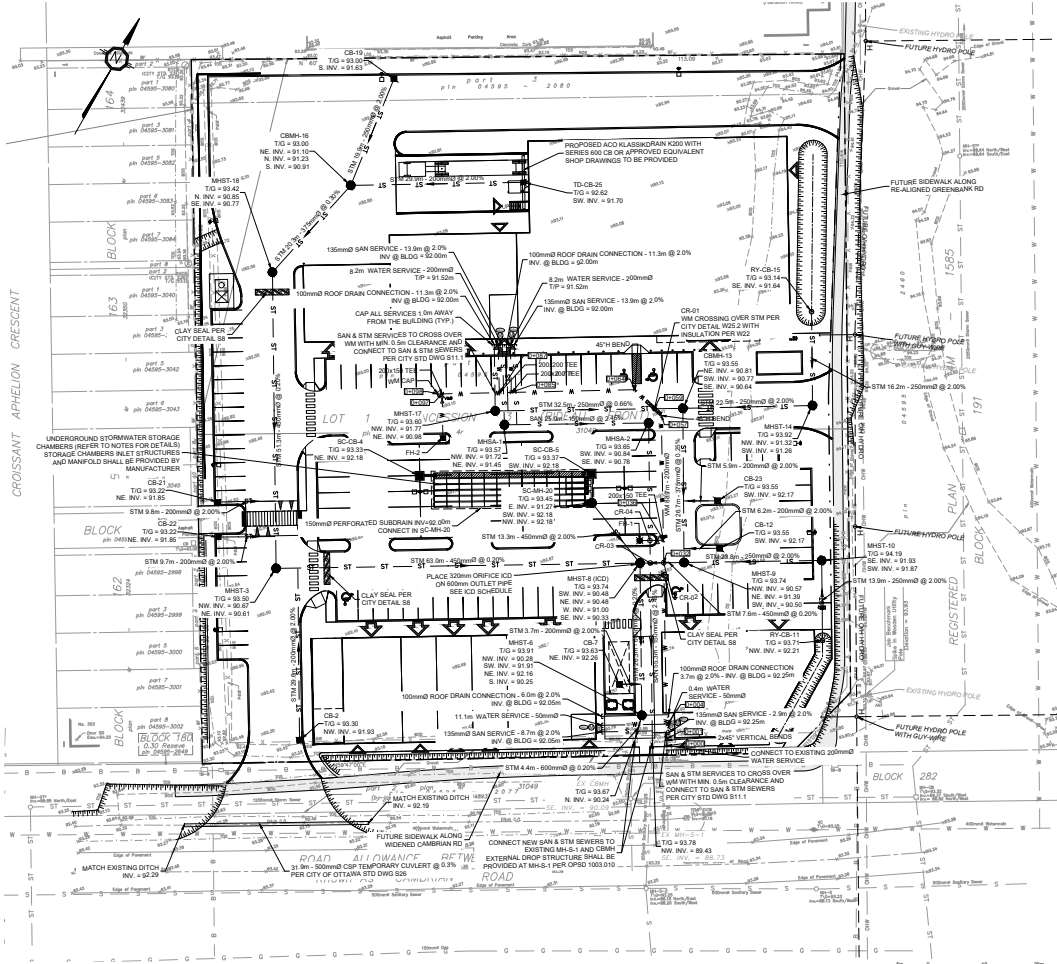
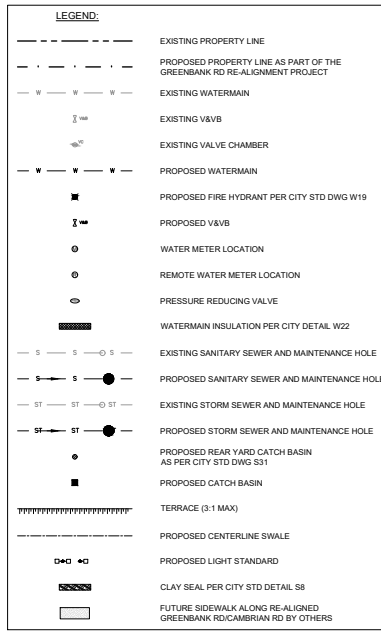

### ICD SCHEDULE

ICD ID	LOCATION	ORIFICE INVERT (m)	FLOW 100y (L/s)	HEAD 100y (m)	EQUIVALENT DIAMETER (mm)	MODEL*
1	MHST-8	90.33	287.6	2.08	320	SEE D2 ON DWG C104

\* ICD SHOP DRAWINGS SHALL BE SUBMITTED TO PARSONS BEFORE COMMENCING ANY WORK

- ### NOTES - UNDERGROUND STORMWATER STORAGE
- UNDERGROUND STORMWATER STORAGE SYSTEM CHAMBER TYPE OR EQUIVALENT STORAGE REQUIREMENT: 70.0m<sup>3</sup>
  - CHAMBER TYPE: STORMWATER STORAGE OR EQUIVALENT
  - BOTTOM GRANULAR PAD ELEVATION & PERFORATED SUBIRAN INVERT: 92.00m
  - BOTTOM OF CHAMBER: 92.00m
  - TOP OF CHAMBER ELEVATION: 92.56m
  - TOP OF SYSTEM TO BE A MINIMUM OF 450mm BELOW PARKING LOT PAVEMENT

### WATERMAN TABLE

STATION	SURFACE ELEVATION	WIM DEPTH	TOP OF WIM ELEV.	INV. OF WIM ELEV.	NOTES
0+000	94.10	3.73m	90.31	90.11	CONNECTION TO EXISTING WATERMAN
0+001	94.10	2.40m	91.70	91.50	2 x 45° VERTICAL BENDS
0+004	94.05	2.40m	91.65	91.45	2 x 50mm WATER SERVICE CONNECTIONS
0+032	93.80	2.40m	91.40	91.20	CR-02 REFER TO CROSSING TABLE
0+036	93.70	2.40m	91.30	91.10	200x150 TEE FOR FIRE HYDRANT LATERAL, CR-04 REFER TO CROSSING TABLE
0+057	93.60	2.40m	91.20	91.00	45° HORIZONTAL BEND
0+059	93.60	2.13m	91.47	91.27	CR-01 REFER TO CROSSING TABLE AND NOTE ON PLAN
0+064	93.60	2.40m	91.20	91.00	45° HORIZONTAL BEND
0+085	93.60	2.40m	91.20	91.00	200x200 TEE, 200mm WATER SERVICE CONNECTION
0+087	93.60	2.40m	91.20	91.00	200x200 TEE, 200mm WATER SERVICE CONNECTION
0+097	93.60	2.40m	91.20	91.00	200x150 TEE FOR FIRE HYDRANT LATERAL
0+098	93.60	2.40m	91.20	91.00	WATER CAP WITH CONCRETE THRUST BLOCK

### CROSSING TABLE

CROSSING NO.	PIPE ELEV. AT CROSSING	PIPE ELEV. AT CROSSING	CLEARANCE
CR-01	STM, TOP, 91.02	WM, INV, 91.27	0.25m
CR-02	STM, TOP, 90.95	WM, INV, 91.20	0.25m
CR-03	SAN, TOP, 90.34	STM, INV, 90.49	0.15m
CR-04	SAN, TOP, 90.43	PH LAT., INV, 91.30	0.87m

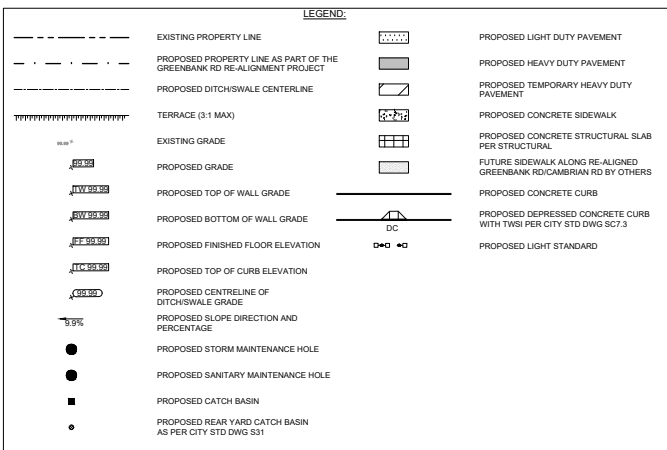
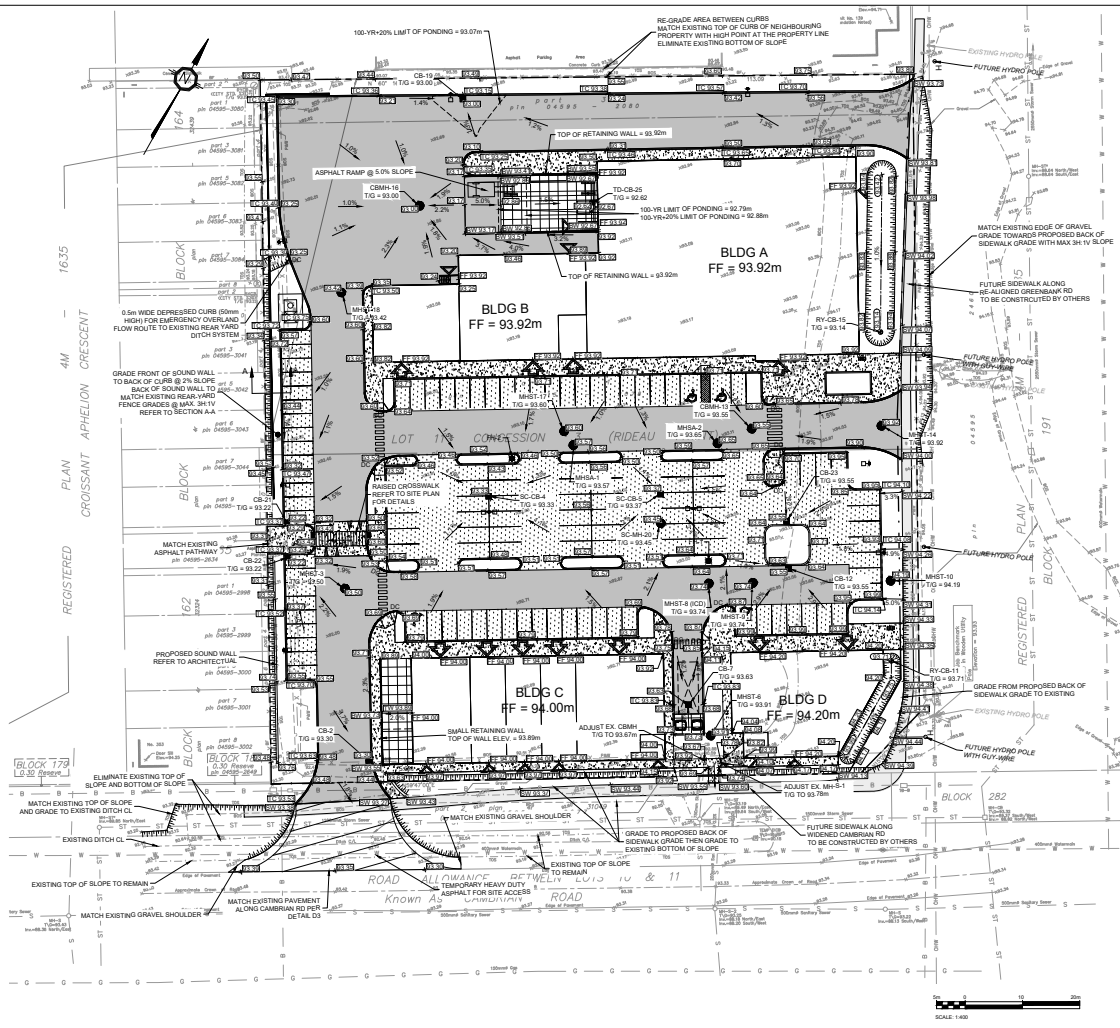

**NOTES - GENERAL**

1. THE CONTRACTOR MUST CONFORM TO ALL LAWS, CODES, ORDINANCES, AND REGULATIONS ADOPTED BY FEDERAL, PROVINCIAL OR MUNICIPAL GOVERNMENT COUNCILS AND GOVERNMENT AGENCIES, APPLYING TO WORK TO BE CARRIED OUT. WHEREVER STANDARDS, LAWS AND REGULATIONS ARE MENTIONED, THEY REFER TO THEIR CURRENT VERSIONS. MODIFICATIONS TO THEM SHALL BE IN ACCORDANCE WITH THE LATEST EDITION OF THE ONTARIO PROVINCIAL STANDARDS SPECIFICATIONS AND DRAWINGS (OPSS) AND OPSS OF THE ONTARIO MINISTRY OF ENVIRONMENT AND CLIMATE CHANGE, THE ONTARIO MINISTRY OF NATURAL RESOURCES, APPLICABLE CONSERVATION AUTHORITIES, THE MANICUNG STANDARDS SPECIFICATIONS AND DRAWINGS, AND ALL OTHER GOVERNING AUTHORITIES AS THEY APPLY. UNLESS OTHERWISE INDICATED.
2. ALL MATERIAL SUPPLIED AND PLACED FOR PARKING LOT AND ACCESS ROAD CONSTRUCTION SHALL BE TO OPSS STANDARDS AND SPECIFICATIONS UNLESS OTHERWISE NOTED. CONSTRUCTION TO OPSS 206, 310 & 314 MATERIALS TO OPSS 901, 902 & 1016.
3. THE LOCATION OF EXISTING UNDERGROUND MUNICIPAL SERVICES AND PUBLIC UTILITIES AS SHOWN ON THE PLANS IS APPROXIMATE. THE CONTRACTOR MUST DETERMINE THE EXACT LOCATION, SIZE, MATERIAL, AND ELEVATION OF ALL EXISTING UTILITIES ON-SITE AND OFF-SITE PRIOR TO ANY EXCAVATION WORK. DAMAGE TO ANY EXISTING SERVICES AND/OR EXISTING UTILITIES DURING CONSTRUCTION, WHETHER OR NOT SHOWN ON THE DRAWINGS MUST BE REPAIRED BY THE CONTRACTOR AT HIS OWN EXPENSE.
4. THE CONTRACTOR SHALL DETERMINE THE EXACT INVERT (GEODETIC ELEVATION), DIAMETER AND CONSTRUCTION MATERIAL OF THE EXISTING CONDUITS AT THE PROPOSED CONNECTIONS. THEY SHALL ALSO CARRY OUT, IF NECESSARY, EXPLORATORY DIGS IN ORDER TO DETERMINE THE EXACT LOCATION AND INVERTS OF EXISTING DUCK BANKS. THIS INFORMATION SHALL IMMEDIATELY BE PROVIDED TO THE CONSULTANT PRIOR TO START UNDERTAKING ANY MUNICIPAL SERVICES WORK AND A 48 HOUR PERIOD MUST BE ALLOCATED TO THE CONSULTANT FOR DESIGN REVIEW.
5. AT PROPOSED UTILITY CONNECTION POINTS AND CROSSINGS (E.G. STORM SEWER, SANITARY SEWER, WATER, ETC.) THE CONTRACTOR SHALL DETERMINE THE PRECISE LOCATION AND DEPTH OF EXISTING UTILITIES AND REPORT ANY DISCREPANCIES OR CONFLICTS TO THE ENGINEER BEFORE COMMENCING WORK. THE CONTRACTOR IS RESPONSIBLE FOR ALL LAYOUT FOR CONSTRUCTION PURPOSES.
6. THE CONTRACTOR IS RESPONSIBLE FOR THE COORDINATION OF ALL WORK AND ACTIVITIES WITH OTHER TRADES AND CONTRACTORS.
7. THE CONTRACTOR IS THE ONLY PERSON IN CHARGE OF SAFETY ON THE BUILDING SITE. THE CONTRACTOR IS RESPONSIBLE FOR PROVIDING ADEQUATE PROTECTION OF THE WORKERS, OTHER PERSONNEL AND THE GENERAL PUBLIC. PROTECTION OF NEIGHBOURING PROPERTIES SHALL BE AS NEARLY AS THE COMPLETED WORK AND WORKS TO BE COMPLETED. THE CONTRACTOR MUST PROVIDE AT ANY TIME, ADEQUATE BARRIERS FOR FENCES, POSTERS, SIGNS AND OTHERS TO ENSURE SAFETY.
8. NECESSARY CONVENIENCES FOR THE COMPLETION OF WORKS SUCH AS HEATING, LIGHTING, VENTILATION, ETC.
9. THE CONTRACTOR SHALL OBTAIN THE NECESSARY PERMITS/APPROVALS REQUIRED TO COMPLETE ALL THE WORKS AND ACTIVITIES AND BEAR COST OF THE SAME. SUCH AS BUT NOT LIMITED TO PERMITS, SEWER PERMITS, WATER PERMIT, ETC. AND THEIR ASSOCIATED COSTS.
10. ALL ELEVATIONS ARE GEODETIC AND UTILIZE METRIC UNITS.
11. JOB BENCH MARKS - CONFORM WITH PAROS PRIOR TO UTILIZATION. THE CONTRACTOR MUST MAINTAIN BENCHMARKS AND LANDMARK REFERENCES AS IS. OTHERWISE THESE REFERENCES WILL BE REESTABLISHED BY A CERTIFIED LAND SURVEYOR AT THE CONTRACTOR'S EXPENSE.
12. ALL GROUND SURFACES SHALL BE EVENLY GRADED WITHOUT PONDING AREAS AND LOW POINTS EXCEPT WHERE APPROVED SWALE OR CATCH BASIN OUTLETS ARE PROVIDED.
13. IF GROUNDWATER IS ENCOUNTERED DURING CONSTRUCTION, Dewatering of excavations shall be required. IT IS ASSUMED THAT GROUNDWATER MAY BE CONTROLLED BY SUMP AND PUMPING METHODS. THE CONTRACTOR SHALL OBTAIN A PERMIT TO TAKE WATER IF SITE CONDITIONS REQUIRE. TAKING MORE THAN A TOTAL OF 400 LITRE/DAY.
14. STRIP AND REMOVE ALL TOPSOIL FROM IMPROVED AREAS. SITE PREPARATION INCLUDES CLEARING, GRUBBING, STRIPPING OF TOPSOIL, DEMOLITION, REMOVAL OF UNSUITABLE MATERIALS, CUT AND FILL AND ROUGH GRADING OF ALL AREAS TO RECEIVE FINISHED SURFACES.
15. FINISHING PROPERTIES GRADE TO BE MATCHED.
16. ALL EDGES OF DISTURBED PAVEMENT SHALL BE SAW CUT TO FORM A NEAT AND STRAIGHT LINE PRIOR TO PLACING NEW PAVEMENT. PAVEMENT REINSTATEMENT SHALL BE WITH STEP JOINTS OF 300mm WIDTH MINIMUM.
17. CURBS TO BE BARRER, CONSTRUCTED AS PER DETAIL 800.10. EXCEPT WHERE INDICATED OTHERWISE ELEVATION AT TOP OF CONCRETE CURBS TO BE 150 mm ABOVE THE ASPHALT UNLESS OTHERWISE SHOWN IN THE DRAWINGS.
18. DEPRESSED CURBS TO BE MOUNTABLE, CONSTRUCTED AS PER OPSS 800.10.
19. LIGHT DUTY AND HEAVY DUTY ASPHALT PAVEMENTS TO BE CONSTRUCTED AS PER TABLE ON DRAWING C103.
20. TRANSITION BETWEEN EXISTING AND PROPOSED PAVEMENT SHALL BE CONSTRUCTED AS PER DETAIL D3 ON DRAWING C104.
21. RESTORE PAVEMENT STRUCTURE AND SURFACES ON EXISTING ROADS TO A CONDITION AT LEAST EQUAL TO ORIGINAL AND TO THE SATISFACTION OF THE MUNICIPAL AUTHORITIES.

23. CLEANLINESS ON THE SITE, INCLUDES THE CONTRACTOR SHALL CLEAN ROADWAYS AT HIS OWN COST AS DIRECTED BY THE OWNER'S REPRESENTATIVE. MATERIALS AND EQUIPMENT MUST BE LAID OUT IN AN ORGANIZED AND SAFE MANNER, AND ALL MATERIAL, EQUIPMENT AND TEMPORARY STRUCTURES WHICH ARE NO LONGER NECESSARY FOR THE EXECUTION OF THE CONTRACT MUST BE REMOVED FROM THE SITE.
24. CONTRACTOR TO ENSURE MITIGATION MEASURES ARE IMPLEMENTED TO REDUCE THE RISK OF GROUND CONTAMINATION FROM PETROLEUM PRODUCTS.
25. THE CONTRACTOR MUST ENSURE THE FOLLOWING MEASURES ARE IMPLEMENTED REGARDING THE HANDLING OF CONCRETE.
  1. CONCRETE SHOULD EITHER BE MIXED AWAY FROM THE SITE OR SHOULD BE PREPARED ON PAVED SURFACES IF ONLY SMALL QUANTITIES ARE REQUIRED (E.G. SNOW REPAIRS).
  2. EXCESS CONCRETE MUST BE DISPOSED OFF-SITE AT A LOCATION THAT MEETS ALL REGULATORY REQUIREMENTS.
  3. THE WASHING OF CONCRETE TRUCKS AND OTHER EQUIPMENT USED FOR MIXING CONCRETE SHOULD NOT BE CARRIED OUT WITHIN 30 METERS OF A WATERCOURSE OR WETLAND AND SHOULD TAKE PLACE OUTSIDE OF THE WORK SITE.
  4. ALL CONCRETE TRUCKS SHOULD COLLECT THEIR WASH WATER AND RECYCLE IT BACK INTO THEIR TRUCKS FOR DISPOSAL OFF-SITE AT A LOCATION MEETING ALL REGULATORY REQUIREMENTS.
26. THE CONTRACTOR SHALL ENSURE THAT ALL EXCAVATED SURPLUS MATERIALS THAT WILL BE REQUIRED TO BE DISPOSED OFF-SITE BE STOCKPILED TEMPORARILY FOR SAMPLING PRIOR BEING LOADED OFF-SITE.
27. MINIMIZE DISTURBANCE TO EXISTING VEGETATION DURING THE EXECUTION OF ALL WORKS.
28. TRENCING, BACKFILLING AND COMPACTING MUST CONFORM TO OPSS 401.
29. OBTAINING OF PIPELINE, UTILITY AND ASSOCIATED STRUCTURE EXCAVATIONS TO BE COMPLETED AS PER OPSS 617.
30. THE CONTRACTOR MUST CONTROL SURFACE RUNOFF FROM PRECIPITATION DURING CONSTRUCTION.
31. FOR ALL GEOTECHNICAL WORK, CONTRACTOR TO REFER TO "GEOTECHNICAL INVESTIGATION REPORT, PROPOSED COMMERCIAL DEVELOPMENT, 3850 CAMBRIAN RD, NEPEAN, OTTAWA, ONTARIO, BY GEOTERRIE LIMITED, DATED APRIL 8, 2021".
32. REMOVE FROM SITE ALL EXCESS EXCAVATED MATERIAL, UNLESS OTHERWISE DIRECTED FROM THE ENGINEER, EXCAVATE AND REMOVE ALL ORGANIC MATERIAL AND DEBRIS LOCATED WITHIN THE PROPOSED BUILDING, PARKING AND ROADWAY LOCATIONS.
33. THE CONTRACTOR IS RESPONSIBLE FOR ALL EXCAVATION, BACKFILL AND REINSTATEMENT OFF ALL AREA DISTURBED DURING CONSTRUCTION TO EXISTING CONDITIONS OR BETTER AND ALL ASSOCIATED WORKS TO THE SATISFACTION OF THE CONSULTANT AND MUNICIPAL AUTHORITIES. ASPHALT REINSTATEMENT MUST BE IN ACCORDANCE WITH OPSS 310 LANDSCAPE AREAS TO BE REINSTATEMENT WITH 150mm OF TOPSOIL AND SOIL IN ACCORDANCE WITH OPSS 800 AND OPSS 803.
34. DURING THE CONSTRUCTION PERIOD, THE CONTRACTOR IS RESPONSIBLE FOR INSTALLING AND MAINTAINING TEMPORARY TRAFFIC SIGNAGE, INCLUDING TRAFFIC LIGHTS, TRAFFIC MARKINGS AND TEMPORARY TRAFFIC LIGHTS, AND SIGNALS AS REQUIRED BY THE ENGINEER, THE CONSULTANT, THE MUNICIPALITY, THE MTO AND OTHER AGENCIES.
35. THE CONTRACTOR SHALL CONSTRUCT SIDEWALK EXPANSION JOINTS & CONTROL JOINTS AS PER OPSS 350.
36. CONSTRUCT CONCRETE SIDEWALK AS PER OPSS 310.020 AND OPSS 351. TACTILE PAVEMENT SURFACE INDICATORS PER OPSS 351.
37. DISPOSE OF CONTAMINATED MATERIALS AT APPROPRIATE OFF-SITE FACILITY THAT IS PREPARED TO INTERCEPT, CLEAN UP, AND DISPOSE OF SPILLS OR RELEASES THAT MAY OCCUR WHETHER ON LAND OR WATER. MAINTAIN MATERIALS AND EQUIPMENT REQUIRED FOR CLEANUP OF SPILLS OR RELEASES READILY ACCESSIBLE ON SITE.
38. PROMPTLY REPORT SPILLS AND RELEASES POTENTIALLY CAUSING DAMAGE TO ENVIRONMENT TO AUTHORITY HAVING JURISDICTION OR INTEREST IN SPILL OR RELEASE INCLUDING CONSERVATION AUTHORITY, WATER SUPPLY AUTHORITIES, NEIGHBOURING ROAD AUTHORITY AND FIRE DEPARTMENT.
39. DECONTAMINATE EQUIPMENT AFTER WORKING IN A POTENTIALLY CONTAMINATED AREA. CONTRACTOR SHALL MAINTAIN RECORDS OF ALL DECONTAMINATION WORK. DO NOT DISCHARGE DECONTAMINATED WATER, OR SURFACE WATER RUNOFF, OR CONTAMINATED WASH WATER INTO ANY WATERCOURSE OR WATER BODY. CONTRACTOR TO MAINTAIN RECORDS OF ALL DECONTAMINATION WORK. DO NOT CONTACT WITH POTENTIALLY CONTAMINATED MATERIAL, OFF SITE OR TO MUNICIPAL SERVICES.
40. CONTRACTOR TO SUBMIT THE MANAGEMENT PLAN FOR APPROVAL ONE (1) WEEK PRIOR TO ANY WORK WITHIN THE ROW LIMITS TO MEET THE REQUIREMENTS OF MTD BOOK 7. THE CONTRACTOR WILL BE REQUIRED TO IMPLEMENT ALL REQUIREMENTS OF MTD BOOK 7.
41. CITY PUBLIC WORKS DEPARTMENT TO BE CONTACTED MINIMUM 7 DAYS PRIOR TO PLANNED DATE FOR CONNECTION TO EXISTING STORM SEWERS, SANITARY SEWERS, AND WATERMAIN. CONNECTION TO EXISTING TO TAKE PLACE IN THE PRESENCE OF APPROPRIATE CITY OF OTTAWA STAFF.

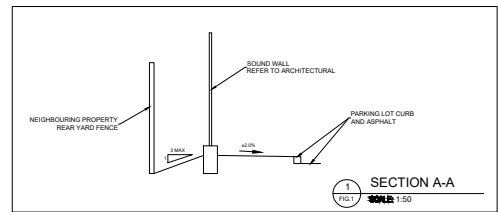

PAVEMENT STRUCTURES			
MATERIAL	LIGHT DUTY	HEAVY DUTY	COMPACTION
SURFACE LAYER - H-3	40 mm	40 mm	≥ 92%
BASE LAYER - H-6	40 mm	60 mm	≥ 92%
GRANULAR SUB-BASE - OPSS MUNI 1010 GRANULAR A	200 mm	200 mm	100%**
GRANULAR SUB-BASE - EXISTING GRANULAR BASE PLACED DURING INITIAL SITE GRADING	min. 350 mm	min. 350 mm	100%**

\*MINIMUM PAVEMENT COMPACTION BASED ON MAXIMUM RELATIVE DENSITY, PER OPSS MUNI 310  
 \*\*OF THE STANDARD PROCTOR MAXIMUM DRY DENSITY

SOURCE: GEOTECHNICAL INVESTIGATION REPORT, PROPOSED COMMERCIAL DEVELOPMENT, 3850 CAMBRIAN RD, NEPEAN, OTTAWA, ONTARIO, BY GEOTERRIE LIMITED, DATED APRIL 8, 2021

**TURNER FLEISCHER**  
 Turner Fleischer Architects Inc.  
 67 Leavelle Road  
 Toronto, ON M8Z 5T4  
 T 416 425 2222  
 turnerfleischer.com

The Planning, an independent practice, is provided to the property of Turner Fleischer Architects Inc. The information is provided for the project of Turner Fleischer Architects Inc. and is not to be used for any other project without the written consent of Turner Fleischer Architects Inc. All rights reserved. No part of this document may be reproduced, stored in a retrieval system, or transmitted in any form or by any means, electronic, mechanical, photocopying, recording, or by any information storage and retrieval system, without the prior written permission of Turner Fleischer Architects Inc.

**PARSONS**  
 1880 MONROE STREET, SUITE 100, OTTAWA, ONTARIO K1T 5L7  
 T 613 735 7700  
 parsons.com

**TOPOGRAPHIC INFORMATION & BENCHMARK**  
 SURVEY COMPLETED BY ANNE O'SULLIVAN, VOLLEBERG LTD. ON OCTOBER 01, 2022. ELEVATIONS SHOWN ARE GEODETIC AND ARE REFERRED TO THE CGVD05 GEODETIC DATUM. DERIVED FROM CONTROL MONUMENT NO. 019888011 HAVING AN ELEVATION OF 59.740m.

PROJECT	3850 CAMBRIAN RD
DATE	2022-08-19
SCALE	AS SHOWN
PROJECT NO.	4782006
PROJECT DATE	2022-08-19
DESIGNED BY	BY
CHECKED BY	MT
IN CHARGE	PC
AS INDICATED	As Indicated

**Choice Properties**

PROJECT: 3850 CAMBRIAN RD  
 BARRHAVEN, ONTARIO

GRADING PLAN

PROJECT NO: 4782006  
 PROJECT DATE: 2022-08-19  
 DESIGNED BY: BY  
 CHECKED BY: MT  
 IN CHARGE: PC  
 AS INDICATED

10192000  
 CHIEF OF EST. DIV.

C103

**SILT SACK DETAIL**

320mm Ø ORIFICE PLATE WITH FRAME BOLTED & SEALED OVER THE OUTLET PIPE

600mm Ø OUTLET PIPE

320mm Ø ORIFICE PLATE WITH FRAME BOLTED & SEALED OVER THE OUTLET PIPE

**PARSONS** D1

**FRAME & PLATE ICD**  
N.S.

NO SHOP DRAWINGS SHALL BE PROVIDED TO PARSONS BEFORE COMMENCING ANY WORK

**PARSONS** D2

**NEW TO EXISTING PAVEMENT PERPENDICULAR TRANSITION TREATMENT**  
N.T.S.

**PARSONS** D3

**PRECAST CONCRETE MAINTENANCE HOLE**  
1200mm DIAMETER

ALTERNATIVES

**PARSONS** OPSD 701.010

**PRECAST CONCRETE MAINTENANCE HOLE**  
1000mm DIAMETER

ALTERNATIVES

**PARSONS** OPSD 701.012

**MAINTENANCE HOLE BENCHING AND PIPE OPENING ALTERNATIVES**  
N.T.S.

**PARSONS** OPSD 701.021

**PRECAST CONCRETE CATCH BASIN**  
600x600mm

**PARSONS** OPSD 705.010

**MANHOLE SHAFT**  
TYPICAL MANHOLE SHAFT

**PARSONS** OPSD 1033.010

**MANHOLE SHAFT**  
TYPICAL MANHOLE SHAFT

**PARSONS** OPSD 1033.010

**CAST-IN-PLACE CONCRETE CURB STRUCTURE**  
TYPICAL

**PARSONS** OPSD 1033.010

**HEAVY DUTY 'FISH' TYPE SQUARE CATCH BASIN COVER**  
N.T.S.

**Ottawa**

**SEWER SERVICE CONNECTIONS FOR FLEXIBLE MAN SEWER PIPE**  
(MODIFIED OPSD-1006-020)

**Ottawa**

**STANDARD CIRCULAR SANITARY & COMBINED MAINTENANCE HOLE COVER**  
N.T.S.

**Ottawa**

**STANDARD CIRCULAR STORMWATER MAINTENANCE HOLE COVER**  
N.T.S.

**Ottawa**

**CONCRETE BARRIER CURB FOR GRANULAR BASE PAVEMENT**  
(MODIFIED OPSD-061.10)

**Ottawa** N.T.S.

**SIDEWALK CONSTRUCTION JOINTS**  
N.T.S.

**Ottawa**

**INSTALLATION OF CATCH BASIN WITH TYPICAL CURB BARRIER AND DEPRESSED CURB**  
N.T.S.

**Ottawa**

**STANDARD CIRCULAR FRAME FOR MAINTENANCE HOLES**  
(MODIFIED OPSD-061)

**Ottawa**

**CATCH BASIN MAINTENANCE HOLE COVER**  
(MODIFIED OPSD-061)

**Ottawa**

**LIGHT-DUTY SILT FENCE BARRIER**  
N.T.S.

**PARSONS** OPSD 219.110

**COLOR TEXTURED CURB FOR CURB MAIN PIPE STREET**  
N.T.S.

**PARSONS** OPSD 701.010

**CONCRETE BARRIER CURB WITH SIDEWALK**  
N.T.S.

**Ottawa**

**CATCH BASIN CONNECTION FOR FLEXIBLE MAN PIPE SEWER**  
N.T.S.

**PARSONS** OPSD 708.030

**SINGLE TRENCH (SEWER & SEWER SERVICES)**  
N.T.S.

**Ottawa**

**COMBINED TRENCH (SEWER & SEWER SERVICES)**  
N.T.S.

**Ottawa**

**CLAY SEAL FOR PIPE TRENCHES**  
N.T.S.

**Ottawa**

**PRIVATE ENTRANCE DETAIL - RURAL**  
N.T.S.

**PARSONS**

**PRIVATE ENTRANCE DETAIL - RURAL**  
N.T.S.

**PARSONS**

**TURNER FLEISCHER**

Turner Fleischer Architects Inc.  
47 Leavelle Road  
Toronto, ON M6H 2T6  
T: 416-463-2222  
info@turnerfleischer.com

**PARSONS**

1885 MONROE STREET, SUITE 100, OTTAWA, ONTARIO K1J 9L6  
TEL: 613-947-9100

**Choice Properties**

PROJECT: 3850 CAMBRIAN RD  
BARRHAVEN, ONTARIO

DETAIL PAGE 1

PROJECT NO: 478556  
PROJECT DATE: 2022-08-19  
DESIGNED BY: [Signature]  
CHECKED BY: MT  
SCALE: N.T.S.



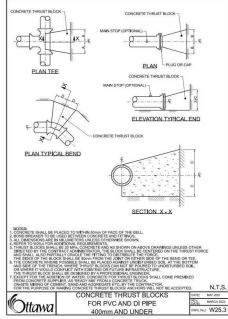
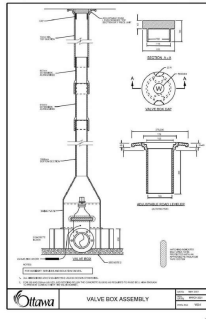
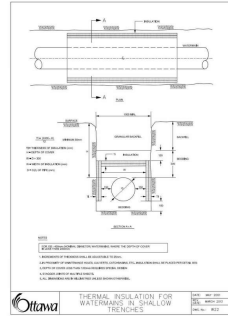
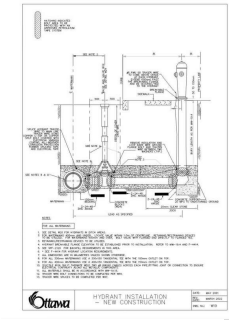
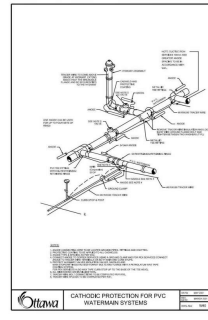
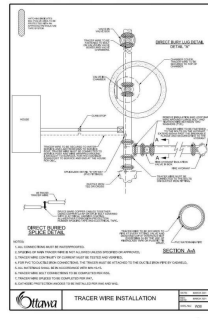
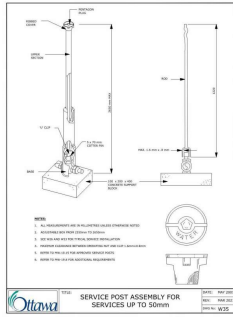
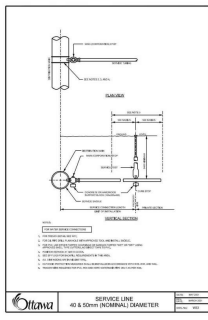
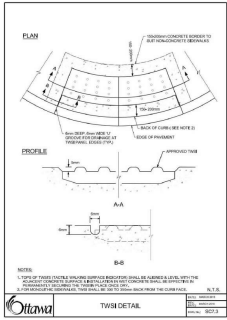

**CLASS**

**PROFILE**

**NOTES**

**Ottawa** THRUST BLOCK DIMENSION TABLES FOR PVC AND DI PIPE 400mm AND UNDER

PIPE SIZE (mm)	THRUST BLOCK LENGTH (mm)	THRUST BLOCK WIDTH (mm)	THRUST BLOCK HEIGHT (mm)
40	100	100	100
50	125	125	125
75	175	175	175
100	225	225	225
125	275	275	275
150	325	325	325
200	425	425	425
250	525	525	525
300	625	625	625
350	725	725	725
400	825	825	825

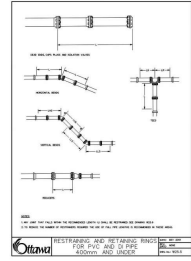

**CLASS**

**PROFILE**

**NOTES**

**Ottawa** TABLES OF RESTRAINED LENGTHS FOR PVC AND DI PIPE 400mm AND UNDER

PIPE SIZE (mm)	RESTRAINED LENGTH (mm)
40	100
50	125
75	175
100	225
125	275
150	325
200	425
250	525
300	625
350	725
400	825

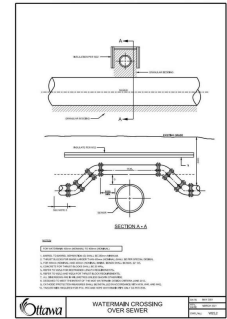
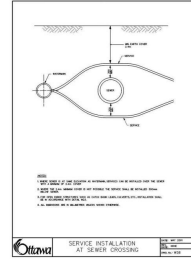

**TURNER FLEISCHER**

Turner Fleischer Architects Inc.  
 67 Leavelle Road  
 Toronto, ON M6G 2T4  
 T 416 425 2222  
 turner@turnerfleischer.com

This drawing is an instrument of service, it is provided by and for the property of Turner Fleischer Architects Inc. The recipient shall not use or reproduce this drawing for any other project without the written consent of Turner Fleischer Architects Inc. If any portion of this drawing is to be used for any other project, the recipient shall obtain the written consent of Turner Fleischer Architects Inc. Turner Fleischer Architects Inc. shall not be responsible for any errors or omissions in this drawing. The recipient shall be responsible for any errors or omissions in this drawing. Turner Fleischer Architects Inc. shall not be responsible for any errors or omissions in this drawing. The recipient shall be responsible for any errors or omissions in this drawing.

**PARSONS**

180 MONROE STREET, SUITE 100, OTTAWA, ONTARIO K1T 5M6  
 Tel: 613-943-6100 Fax: 613-943-1700

PROJECT NO. 4742656  
 PROJECT DATE 2022-08-19  
 DRAWN BY BV  
 CHECKED BY MT  
 TITLE POOLS  
 NTS

PROJECT 3850 CAMBRIAN RD  
 BARRHAVEN, ONTARIO

DRAWING DETAIL PAGE 2

PROJECT NO. 4742656  
 PROJECT DATE 2022-08-19  
 DRAWN BY BV  
 CHECKED BY MT  
 TITLE POOLS  
 NTS

DATE 2022-08-19  
 10190202  
 TURNER FLEISCHER ARCHITECTS INC.

C105

FILE# 007125049

# TURNER FLEISCHER

Turner Fleischer Architects Inc.  
47 Leavelle Road  
Toronto, ON M6H 2T6  
T 416 425 2222  
turnerfleischer.com

This drawing is an indication of practice to be provided to and on the property of Turner Fleischer Architects Inc. It is not intended to be used for any other purpose. The user of this drawing is responsible for its use. Turner Fleischer Architects Inc. is not responsible for any errors or omissions in this drawing. The user of this drawing is responsible for its use. Turner Fleischer Architects Inc. is not responsible for any errors or omissions in this drawing. The user of this drawing is responsible for its use.



1885 MONAGHAN STREET, SUITE 105, OTTAWA, ONTARIO K1T 5H6  
Tel: 613-849-1100 Fax: 613-849-1101

**LEGEND:**

- WATERSHED BOUNDARY
- WATERSHED NAME
- RUNOFF COEFFICIENT
- AREA IN HECTARES
- EMERGENCY OVERLAND FLOW ROUTE

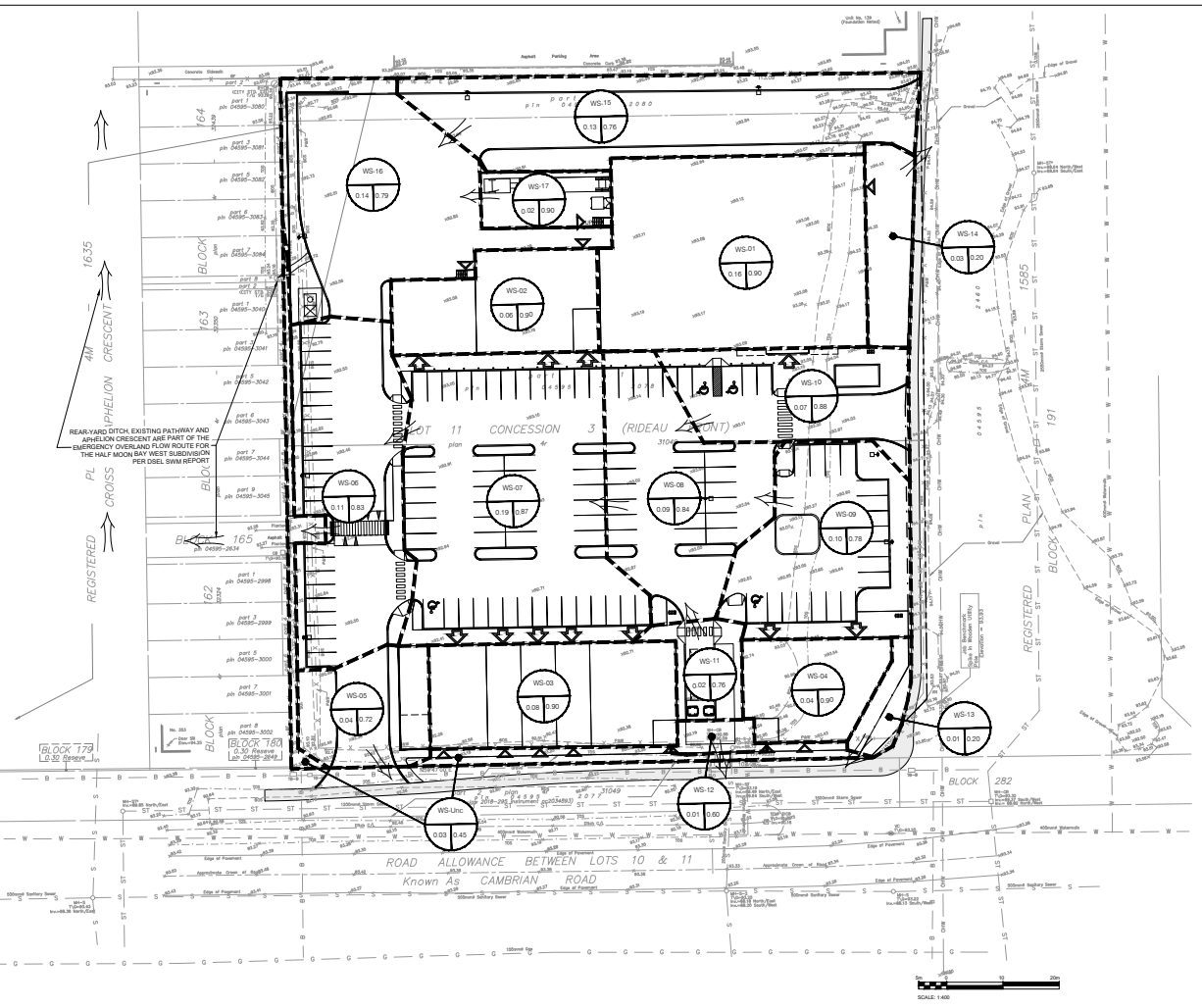

DATE	DESCRIPTION	BY
2022-08-19	CONCEPTUAL DRAINAGE PLAN	MT
2022-08-19	CONCEPTUAL DRAINAGE PLAN	MT



**PROJECT**  
3850 CAMBRIAN RD  
BARRHAVEN, ONTARIO

**POST-DEVELOPMENT DRAINAGE AREAS**

PROJECT NO:	478356
PROJECT DATE:	2022-08-19
DESIGNED BY:	MT
CHECKED BY:	MT
SCALE:	As Indicated



DATE: **C106** REV: \_\_\_\_\_

NUMBER: 00172-25-001