

- GENERAL NOTES:**
- It is the responsibility of the appropriate contractor or official to report any errors, omissions or discrepancies on this plan with actual site conditions to the Landscape Architect before proceeding with construction.
  - The contractor is to notify all utility companies and authorities prior to any excavation and ascertain locations of underground services.
  - The contractor is to reinstate all areas and items damaged as a result of construction activity.
  - The contractor is to comply with all pertinent codes and by-laws.
  - The contractor is to maintain a positive surface run-off throughout the entire construction period.
  - The Landscape Architect is not responsible for subsurface conditions.
  - The contractor is to identify all existing trees to remain on site with the Landscape Architect prior to construction.
  - The contractor is to stake the proposed location of all plant material in conjunction with the Landscape Architect prior to excavation.
  - Minimum distances for selected deciduous trees are as follows:
    - Building Foundations 7.5m
    - Sidewalks 1.5m
    - Public Streets 2.5m
    - Underground Infrastructure 2.0m
  - All trees within 1m of underground utility trenches are to be excavated by hand.
  - Remove all protective wrapping from tree trunks after installation.
  - Staking of trees shall only be performed if necessary.
  - Ensure that mulch is pulled back a min. distance of 75mm from base of tree trunk.

CLIENT

**SMART LIVING PROPERTIES**

CONSULTANTS

ARCHITECTS:

**WOODMAN ARCHITECT ASSOCIATES LTD.**

ENGINEERS:

**McINTOSH PERRY**

**LEGEND**

- EXISTING TREE TO REMAIN
- PROPOSED DECIDUOUS TREE
- PROPOSED SHRUBS / PERENNIALS
- PROPOSED RIVERSTONE MULCH
- PROPOSED SOD
- PROPOSED PRECAST CONCRETE PAVERS
- PROPOSED TREE PROTECTION FENCE
- PROPOSED 2.1m HT. ORNAMENTAL METAL FENCE
- PROPOSED 2.1m HT. CHAIN LINK FENCE
- PROPOSED PICNIC TABLE
- AREA TO BE EXCAVATED WITH HYDRO VAC
- PROPOSED 450x600x1000mm BOULDERS
- PROPOSED 150mm dia. BOLLARD

7	REVISED PER NEW SITE PLAN	10/26/2023	ML	JL
6	REVISED PER CITY COMMENTS	10/04/2023	ML	JL
5	REVISED PER CITY COMMENTS	08/11/2023	ML	JL
4	REVISED PER NEW SITE PLAN	02/08/2023	ML	JL
3	REVISED PER NEW SITE PLAN	01/20/2023	ML	JL
2	ISSUED FOR SITE PLAN APPLICATION	06/20/2022	SL	JL
1	ISSUED FOR DISCUSSION AND REVIEW	06/17/2022	ML	JL

No. Issue Date DR CK

**JAMES B. LENNOX & ASSOCIATES INC.**  
 LANDSCAPE ARCHITECTS  
 3332 CARLING AVE. OTTAWA, ONTARIO K2H 5A8  
 Tel: (613) 722-5168 Fax: (866) 343-3942

PROJECT

PROPOSED RENOVATIONS

146-170 OSGOODE, OTTAWA ON

DRAWING

TREE CONSERVATION REPORT & LANDSCAPE PLAN

SCALE

AS SHOWN

START DATE

JUNE 2022

PROJECT NO.

22MIS2250

PROJECT NORTH

DRAWING NO.

**L.1**

PLOT SIZE ARCH-D

**PROPOSED PLANT LIST**

KEY	QTY.	BOTANICAL NAME	COMMON NAME	SIZE	CONDITION	REMARKS
<b>TREES</b>						
AG	1	<i>Acer ginnala</i>	Amur Maple	60mm ø	B&B	
HL	1	<i>Gleditsia inaequalis</i> 'Draves'	Street Keeper Honey Locust	60mm ø	B&B	
MP	1	<i>Malus 'Profusion'</i>	Profusion Crabapple	60mm ø	B&B	
<b>SHRUBS</b>						
AC	10	<i>Ribes alpinum</i>	Alpine Currant	600mm ht.	Potted	1200mm o.c.
AH	13	<i>Hydrangea arborescens</i> 'Annabelle'	Annabelle Hydrangea	1 gallon pot	Potted	1000mm o.c.
BB	2	<i>Euonymus alatus</i>	Burning Bush	1 gallon pot	Potted	
BS	5	<i>Spiraea x vanhouttei</i>	Bridal Wreath Spiraea	600mm ht.	Potted	1200mm o.c.
DMP	20	<i>Pinus mugo</i>	Dwarf Mugo Pine	600mm ht.	Potted	
DN	4	<i>Physocarpus opulifolius</i>	Common Ninebark	600mm ht.	Potted	
DW	2	<i>Cornus sericea</i>	Red Osier Dogwood	600mm ht.	Potted	
GS	4	<i>Spiraea x arguta</i>	Garland Spiraea	600mm ht.	Potted	
MJ	12	<i>Juniperus chinensis</i>	Mint Juniper	600mm ht.	Potted	
MO	2	<i>Philadelphus 'Miniature Snowflake'</i>	Miniature Mock Orange	3 Gallon Pot	Potted	
PG	2	<i>Hydrangea paniculata</i> 'Peegee'	Peegee Hydrangea	3 gallon pot.	Potted	1200mm o.c.
RR	17	<i>Rosa rugosa</i>	Rugosa Rose	600mm spr.	Potted	1200mm o.c.
SF	18	<i>Sorbaria sorbifolia</i> 'Sem'	Sem False Spiraea	600mm ht.	Potted	1200mm o.c.
<b>PERENNIALS AND ORNAMENTAL GRASSES</b>						
KF	6	<i>Calamagrostis 'Karl Forester'</i>	Karl Forester Grass	250mm pot	Potted	800 mm o.c.

**EXISTING TREE LIST**

KEY	QTY.	BOTANICAL NAME	COMMON NAME	SIZE	CONDITION	REMARKS	OWNERSHIP
AN	AP	<i>Acer negundo</i>	Manitoba Maple	500mm DBH	GOOD	To remain	City of Ottawa
AP	6	<i>Acer platanoides</i>	Norway Maple	300-400mm DBH	GOOD	To remain	City of Ottawa
CK	1	<i>Acer platanoides</i> 'Crimson King'	Crimson King Maple	350mm DBH	GOOD	To remain	City of Ottawa
NM	2	<i>Acer platanoides</i>	Norway Maple	350mm DBH	GOOD	To remain	70 Sweetland Avenue
SH	1	<i>Sorbus x hybrida</i>	Oakleaf Mountain Ash	300mm DBH	GOOD	To remain	City of Ottawa
TA	1	<i>Tilia americana</i>	Basswood	3x400mm DBH	GOOD	To remain	City of Ottawa
TC	1	<i>Tilia cordata</i>	Littleleaf Linden	500mm DBH	GOOD	To remain	City of Ottawa

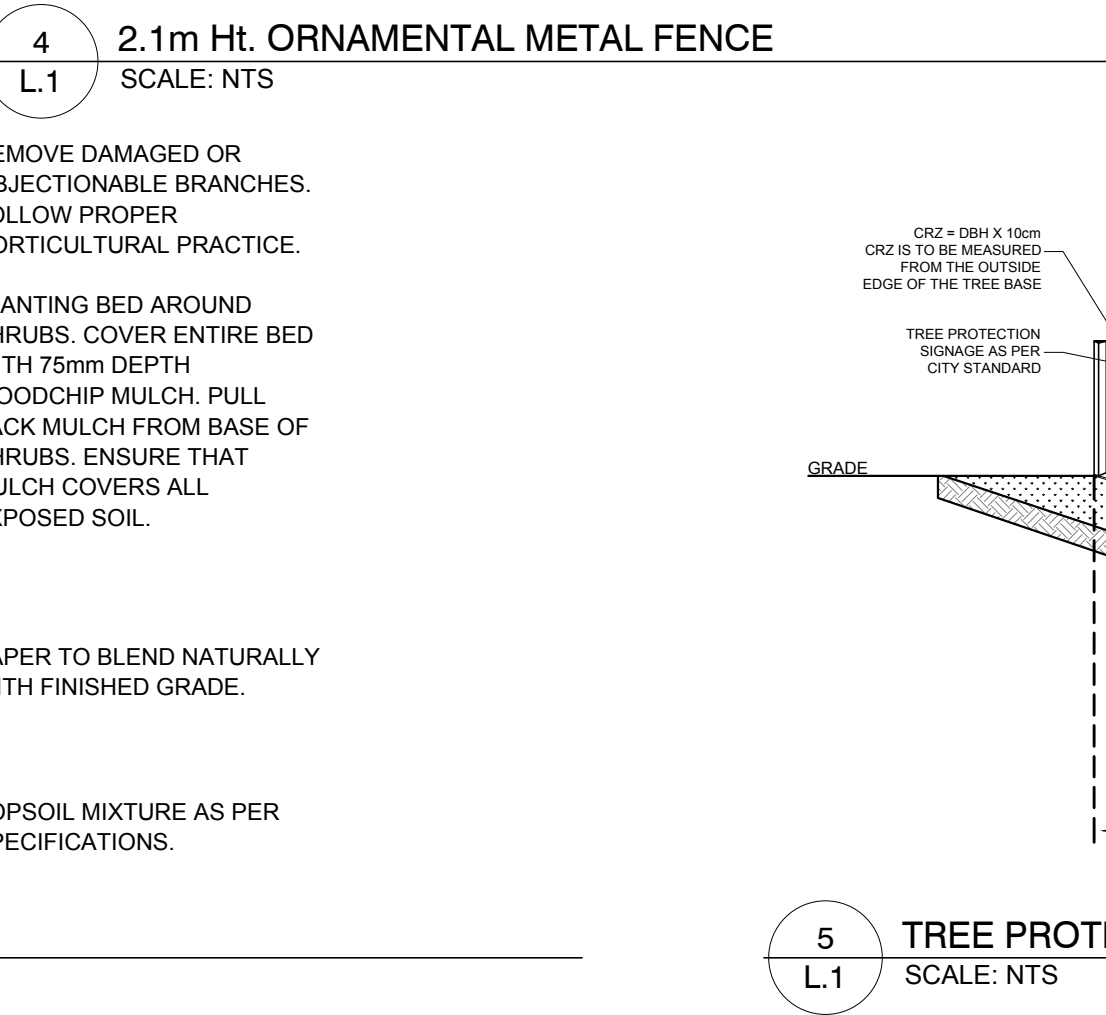
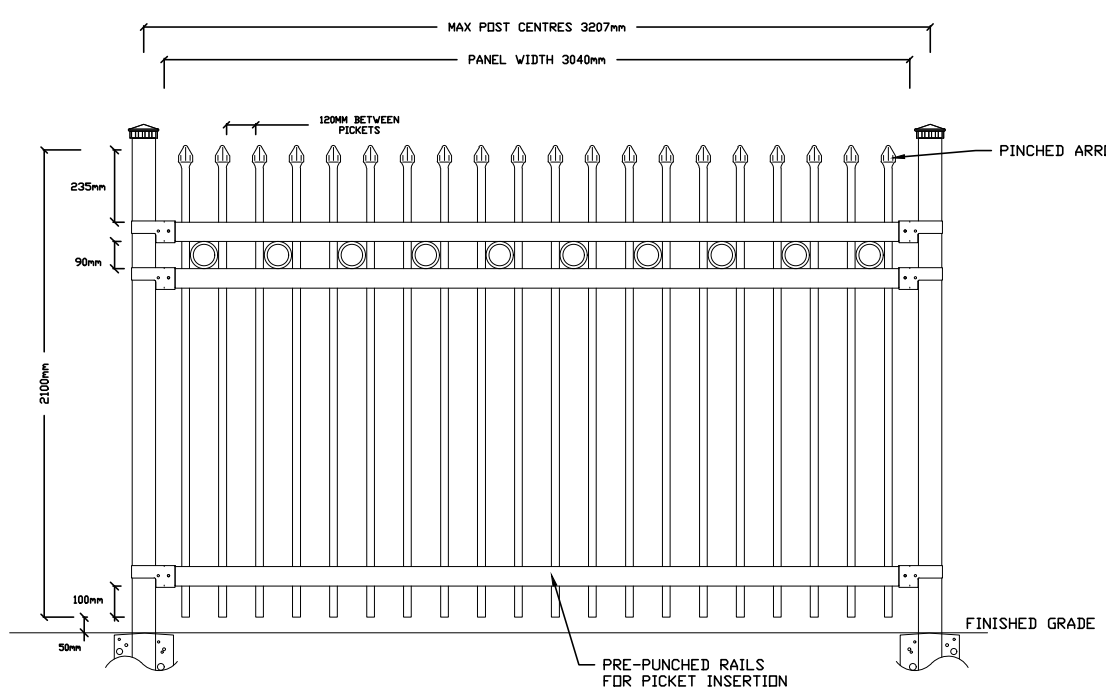
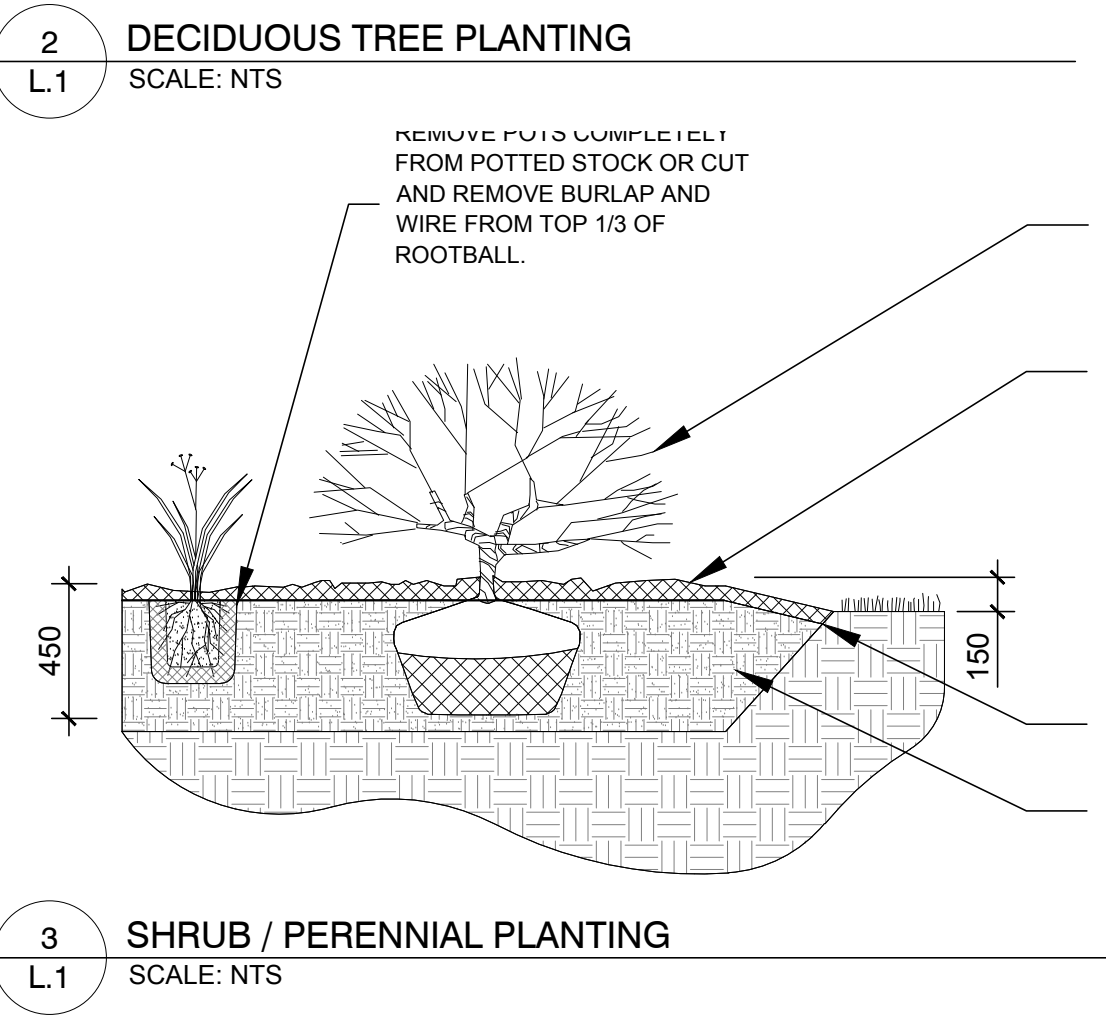
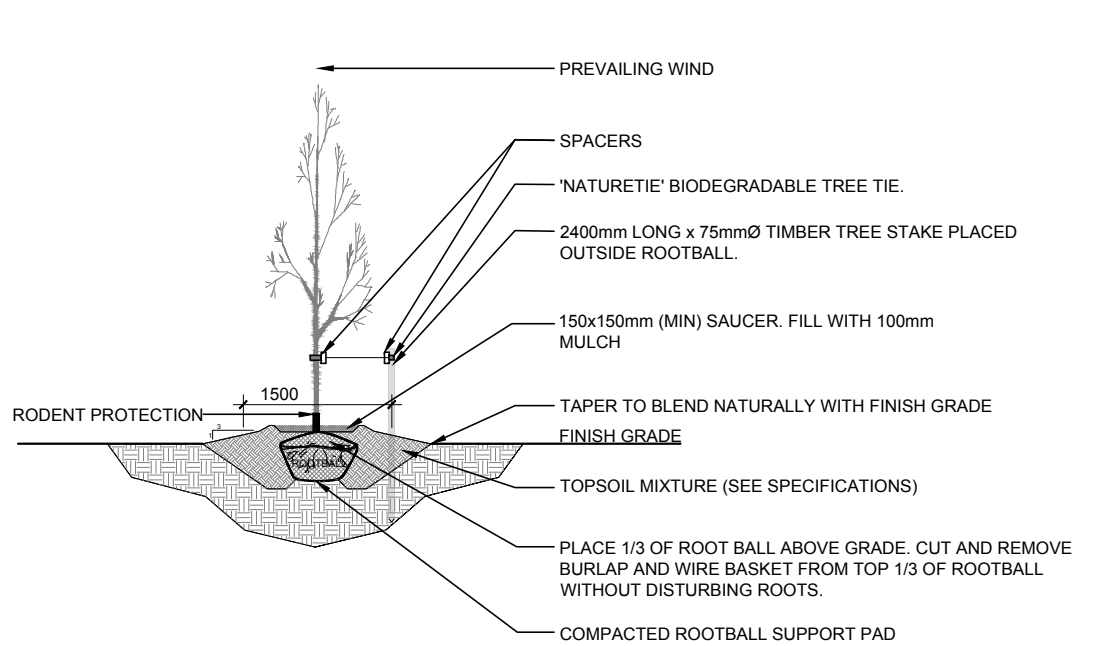

**TREE PROTECTION REQUIREMENTS:**

- PRIOR TO ANY WORK ACTIVITY WITHIN THE CRITICAL ROOT ZONE (CRZ) OF A TREE, TREE PROTECTION FENCING MUST BE INSTALLED SURROUNDING THE CRITICAL ROOT ZONE AND REMAIN IN PLACE UNTIL THE WORK IS COMPLETE.
  - DO NOT PLACE ANY MATERIAL OR EQUIPMENT INCLUDING OUTHOUSES, SIGNAGE, NOTICES OR POSTERS TO ANY TREE.
  - DO NOT RAISE OR LOWER THE EXISTING GRADE, TUNNEL OR BORE WHEN DIGGING.
  - DO NOT DAMAGE THE ROOT SYSTEM, TRUNK, OR BRANCHES OF ANY TREE.
  - ENSURE THAT EXHAUST FUMES FROM ALL EQUIPMENT ARE NOT DIRECTED TOWARD ANY TREE CANOPY.
  - DO NOT EXTEND HAND SURFACE OR SIGNIFICANTLY CHANGE LANDSCAPING.
- TREE PROTECTION FENCING MUST BE AT LEAST 1.2m IN HEIGHT, AND BE CONSTRUCTED OF RIGID OR FRAMED MATERIALS (E.G. WOOD/LOU-STEEL PLYWOOD HOARDING, OR SNOW FENCE ON A 2"x4" WOOD FRAME) WITH POSTS 2.4m APART, SUCH THAT THE FENCE LOCATION CANNOT BE ALTERED. ALL SUPPORTS AND BRACING MUST BE PLACED OUTSIDE OF THE CRZ, AND INSTALLATION MUST MINIMIZE DAMAGE TO EXISTING ROOTS. (SEE DETAIL).
- THE LOCATION OF THE TREE PROTECTION FENCING MUST BE DETERMINED BY AN ARBORIST AND DETAILED ON ANY ASSOCIATED PLANS FOR THE SITE, (E.G. TREE CONSERVATION REPORT, TREE DISCLOSURE REPORT, ETC.). THE PLAN AND CONSTRUCTION FENCING MUST BE APPROVED BY CITY FORESTRY STAFF PRIOR TO THE COMMENCEMENT OF WORK.
- IF THE FENCED TREE PROTECTION AREA MUST BE REDUCED TO FACILITATE CONSTRUCTION, MITIGATION MEASURES MUST BE PRESCRIBED BY AN ARBORIST AND APPROVED BY CITY FORESTRY STAFF. THESE MAY INCLUDE THE PLACEMENT OF PLYWOOD, WOOD CHIPS OR STEEL PLATING OVER THE ROOTS FOR PROTECTION OR THE PROPER PRUNING AND CARE OF ROOTS WHERE ENCOUNTERED.

**BY-LAWS:**

ALL CITY-OWNED TREES ARE PROTECTED UNDER THE MUNICIPAL TREES AND NATURAL AREAS PROTECTION BY-LAW (2008-279), WITHIN THE URBAN AREA.

PRIVATELY-OWNED TREES GREATER THAN 50cm IN DIAMETER ON LOTS 1 HECTARE IN SIZE OR LESS, AND TREES GREATER THAN 10cm IN DIAMETER ON LOTS GREATER THAN 1 HECTARE, ARE PROTECTED UNDER THE URBAN TREE CONSERVATION BY-LAW (2009-200).