

SERVICING AND STORMWATER MANAGEMENT REPORT 294/300 TREMBLAY ROAD – RESIDENTIAL BUILDING



MP Project No.: CP-20-0190
City File No.: PC2023-0154

Prepared for:
ZW Project Management Inc.
150 Richmond Road
Ottawa, ON
K1W 6W2

Prepared by:
McIntosh Perry
115 Walgreen Road
Carp, ON
K0A 1L0

October 5th, 2023

McINTOSH PERRY

TABLE OF CONTENTS

1.0	PROJECT DESCRIPTION	1
1.1	<i>Purpose</i>	1
1.2	<i>Site Description</i>	1
2.0	BACKGROUND STUDIES.....	1
3.0	PRE-CONSULTATION SUMMARY	2
4.0	EXISTING SERVICES.....	2
5.0	SERVICING PLAN.....	2
5.1	<i>Proposed Servicing Overview</i>	2
5.2	<i>Proposed Water Design</i>	3
5.3	<i>Proposed Sanitary Design</i>	4
5.4	<i>Proposed Storm Design</i>	5
6.0	PROPOSED STORMWATER MANAGEMENT	6
6.1	<i>Design Criteria and Methodology</i>	6
6.2	<i>Runoff Calculations</i>	6
6.2.1	Pre-Development Drainage.....	7
6.2.2	Post-Development Drainage	7
6.3	<i>Quantity Control</i>	8
6.4	<i>Quality Control</i>	9
7.0	SEDIMENT EROSION CONTROL.....	9
7.1	<i>Temporary Measures</i>	9
8.0	SUMMARY	10
9.0	RECOMMENDATIONS.....	11
10.0	STATEMENT OF LIMITATIONS.....	12

LIST OF TABLES

Table 1: Water Demands.....	3
Table 2: Boundary Conditions Results	4
Table 3: Sanitary Design Criteria.....	5
Table 4: Summary of Estimated Sanitary Flow	5
Table 5 : Pre-Development Runoff Summary.....	7
Table 6 : Post-Development Runoff Summary	7
Table 7: Storage Summary	9

APPENDICES

APPENDIX A: Site Location Map

APPENDIX B: City of Ottawa Pre-Consultation Notes and Correspondence

APPENDIX C: Water Demands and Fire Protection Calculations

APPENDIX D: Sanitary Sewer Calculation

APPENDIX E: Pre-Development Drainage Plan

APPENDIX F: Post-Development Drainage Plan

APPENDIX G: Stormwater Management Calculations

APPENDIX H: City of Ottawa Design Checklist

1.0 PROJECT DESCRIPTION

1.1 Purpose

McIntosh Perry (MP) has been retained by Project 1 Studios to prepare this Servicing and Stormwater Management Report in support of the Site Plan Control process for the proposed mixed use apartment building, located at 294/300 Tremblay Road within the City of Ottawa.

The main purpose of this report is to present a servicing design for the development in accordance with the recommendations and guidelines provided by the City of Ottawa (City), the Rideau Valley Conservation Authority (RVCA), and the Ministry of the Environment, Conservation and Parks (MECP). This report will address the water, sanitary and storm sewer servicing for the development, ensuring that existing and available services will adequately service the proposed development.

This report should be read in conjunction with the following drawings:

- CP-20-0190, C101 – Site Grading, Drainage, and Servicing Plan

1.2 Site Description

The property is located at 294/300 Tremblay Road, within the City of Ottawa. It is described as Lots 79, 80, 81, 82 and 83, Registered Plan No. 320 being all of Pins 04256-0011 (LT) and 04256-0012 (LT). The developable land in question covers approximately 0.11 ha and is located on the south side of Tremblay Road between Avenue L and Belfast Road.

The existing site is currently developed with an asphalt parking lot towards the rear and two small buildings at the corners fronting Tremblay Road. The existing buildings will be demolished to accommodate the proposed development. Adjacent to the property along the south is an asphalt parking lot.

The proposed development consists of a six-storey residential apartment building with retail space on the ground floor at the corner of Tremblay and Avenue L. The limited parking area will be at grade and located off of Avenue L including the garbage area. The parking area will be covered by the stories above the first floor. The total building footprint is approximately 800 m². A site location plan has been provided in Appendix A for reference.

2.0 BACKGROUND STUDIES

Background studies that have been completed for the site include a review of the City of Ottawa as-built drawings, a topographical survey of the site, a geotechnical report and a Phase I Environmental Site Assessment (ESA).

As-built drawings of the existing services within the vicinity of the site were reviewed in order to determine proper servicing and stormwater management schemes for the site.

A topographic survey of the site was completed by J.D.Barnes Ltd. dated August 7th, 2020 and can be found in Appendix 'B'.

The following reports have previously been completed and are available under separate cover:

- Geotechnical Investigation completed by Paterson Group dated August 31, 2023.
- Phase I ESA completed by Paterson Group.

3.0 PRE-CONSULTATION SUMMARY

City of Ottawa Staff have been pre-consulted regarding this proposed development via conference call on April 17th, 2020. Specific design parameters to be incorporated within this design include the following:

- Quantity control to restrict flows from the 100 year post development storm to the 5 year pre development flow rate using a runoff coefficient 'C' of 0.5 or existing (whichever is smaller)
- Time of Concentration (Tc) cannot be less than 10 min;
- Flows to the storm sewer in excess of the allowable release rate, up to and including the 100-year storm event, must be detained on site;
- Best management practices are to be employed on site.

Pre-Consultation notes from the City can be found in Appendix 'B'.

4.0 EXISTING SERVICES

There are existing site services in the surrounding streets which consist of the following:

- Tremblay Road: 305 mm cast iron watermain, 600 mm PVC sanitary and 900 mm concrete storm
- Avenue L: 152 mm cast iron watermain, 225 mm concrete sanitary and roadside ditches for storm
- Belfast Road: 305 mm PVC watermain, 450 mm concrete sanitary and 450 mm concrete storm

There is also a fire hydrant located along Avenue L in front of the property and others within Tremblay Road to provide fire protection.

5.0 SERVICING PLAN

5.1 Proposed Servicing Overview

The overall servicing will be provided via service connections to the mains within Tremblay Road, Belfast Road and Avenue L. A watermain will be extended from the 305 mm diameter watermain within Belfast and the 150 mm diameter from Avenue L. The storm service (for foundation drainage) will be connected to the 900 mm storm sewer within Tremblay. The sanitary service will be connected to the 225 mm sanitary main within Avenue L. Details pertaining to the final proposed servicing locations are shown on the proposed Site Servicing Plan included within the submission package.

5.2 Proposed Water Design

A new 150 mm PVC diameter watermain will be connected to the existing 305 mm watermain within Belfast and to the existing 150 mm diameter watermain within Avenue L, complete with water valves located at the property line. The existing fire hydrants within Avenue L will be used to service the site with fire protection. The water service is designed to have a minimum of 2.4 m of cover.

The Fire Underwriters Survey 2020 (FUS) method was utilized to determine the required fire flow for the site. The 'C' factor (type of construction) for the FUS calculation was determined to be 0.8 (non-combustible). The total effective floor area ('A' value) for the FUS calculation was determined to be 1,844.9 m². The results of the calculations yielded a required fire flow of 3,000 L/min. The detailed calculations for the FUS and OBC can be found in Appendix 'C'.

The water demands for the proposed building have been calculated to adhere to the *Ottawa Design Guidelines – Water Distribution* manual and can be found in Appendix 'C'. The results have been summarized below:

Table 1: Water Demands

Site Area	0.10 ha
Residential and Commercial	350 L/c/d and 28,000 L/ha/day
Average Day Demand (L/s)	0.48
Maximum Daily Demand (L/s)	1.67
Peak Hourly Demand (L/s)	2.51
FUS Fire Flow Requirement (L/s)	50.00
Max Day + Fire Flow (FUS) (L/s)	51.67

The City provided both the estimated minimum and maximum water pressures, as well as the estimated water pressure during fire flow demand for the demands indicated by the correspondence in Appendix 'C'.

Table 2: Boundary Conditions Results

Scenario	Proposed Demands (L/s)	Avenue L. Connection HGL (m H ₂ O)*/kPa	Belfast Road Connection HGL (m H ₂ O)*/kPa
Average Day Demand	0.48	56.4 / 553.3	55.3 / 542.2
Maximum Daily + Fire Flow Demand	51.67	51.6 / 506.2	50.7 / 497.1
Peak Hourly Demand	2.51	38.1 / 373.8	46.7 / 457.8
*Adjusted for an estimated ground elevation of 62.5m above the connection Avenue L connection point and 63.6m above the Belfast Road connection point.			

The normal operating pressure range is anticipated to be 378.8 kPa to 553.3kPa and will not be less than 275 kPa (40 psi). The proposed watermains will meet the minimum required 140 kPa (20 psi) from the *Ottawa Water Guidelines* at the ground level under the maximum daily and fire flow conditions. However, the proposed watermains will exceed 552 kPa (80 psi) during normal operating conditions. Therefore, a pressure check at the completion of construction is required to confirm that pressure control is required.

5.3 Proposed Sanitary Design

A new 200 mm diameter gravity sanitary service will be connected to the existing 225 mm diameter sewer within Avenue L. The sanitary service will be complete with a maintenance manhole (MH1A) just inside the property line as per the City of Ottawa – Sewer Design Guidelines, October 2012, Clause 4.4.4.7 and City of Ottawa Sewer-Use By-Law 2003-514 (14).

The proposed 200mm diameter gravity sanitary service will be installed with a minimum full flow target velocity (cleansing velocity) of 0.6 m/s and a full flow velocity of not more than 3.0 m/s. Design parameters for the site include an infiltration rate of 0.33 L/s/ha. The design parameters have been summarized in Table 3, below.

Table 3: Sanitary Design Criteria

Design Parameter	Value
Residential 1 Bedroom / Bachelor Apartment (100 Units)	1.4 persons/unit
Average Daily Demand	280L/day/person
Commercial / Amenity Space	28,000L/(ha /day)

Table 4, below, summarizes the estimated wastewater flow from the development. Refer to Appendix 'D' for detailed calculations.

Table 4: Summary of Estimated Sanitary Flow

Design Parameter	Total Flow (L/S)
Total Estimated Average Dry Weather Flow	0.48
Total Estimated Peak Dry Weather Flow	1.66
Total Estimated Peak Wet Weather Flow	1.69

The peak design flows for the proposed building were calculated using criteria from the *City of Ottawa – Sewer Design Guidelines, October 2012*. The peak design flow for the proposed site was determined to be 1.69 L/s, therefore the proposed 200 mm diameter lateral has sufficient capacity to convey the flows (See Appendix 'D' for detailed calculations). City Staff were contacted on September 25, 2020 to review proposed design waste water flows of 2.28 L/s. City Staff confirmed there were no concerns for the proposed flows. Revised site statistics have been received after initial consultation, resulting in lower proposed flows for the development. Please See Appendix 'D' for correspondence with City Staff.

5.4 Proposed Storm Design

Stormwater runoff within the parking area will be conveyed by way of overland sheet flow towards Avenue L and to catchbasins within the ROW. There are proposed window wells around the building. It is anticipated

these areas will be drain via perforated pipe and connected to the 150 mm diameter storm service provided. The site will be constructed with adequate grading to ensure that all areas on the site are able to reach a suitable outlet. Please see the Lot Grading, Drainage and Sediment & Erosion Control Plan for detailed locations of the proposed stormwater infrastructure.

Stormwater management (SWM) design for the site will make use of roof storage with 6 roof drains. The intent of the overall stormwater management design is to provide a system capable of capturing runoff, restricting flows to allowable flow rate, and providing the on-site storage necessary to accommodate the reduced runoff rate. The stormwater management design will be further detailed in Section 6.0.

6.0 PROPOSED STORMWATER MANAGEMENT

6.1 Design Criteria and Methodology

Stormwater management for this site will be maintained through positive drainage away from the proposed building or through roof drains. This SWM plan will implement quantity control strategies. The restricted stormwater runoff will be directed to the existing sewer within Tremblay Road. The quantitative and qualitative properties of the storm runoff for both the pre- and post-development flows are further detailed below. Stormwater Best Management Practices (SWM BMP's) will be implemented at the "Lot level" where possible. These concepts will be explained further in Section 6.3.

In summary, the following design criteria have been employed in developing the stormwater management design for the site as directed by the RVCA and the City:

Quantity Control

- Post-development flow (5 & 100 year) is to be restricted to match the 5-year pre-development flow with a C value of 0.5 and time of concentration (Tc) of 10 minutes.

6.2 Runoff Calculations

Runoff calculations presented in this report are derived using the Rational Method, given as:

$$Q = 2.78 CIA \text{ (L/s)}$$

Where	C	= Runoff coefficient
	I	= Rainfall intensity in mm/hr (City of Ottawa IDF curves)
	A	= Drainage area in hectares

It is recognized that the rational method tends to overestimate runoff rates. As a by-product of using extremely conservative prediction method, any facilities that are sized using these results are expected to function as intended in real world conditions.

The following coefficients were used to develop an average C for each area:

	C _{5-Year}	C _{100-Year}
Roofs/Concrete/Asphalt	0.90	1.00
Gravel	0.60	0.75
Undeveloped and Grass	0.20	0.25

As per the City of Ottawa Sewer Design Guidelines, the 5-year 'C' value must be increased by 25% for a 100-year storm event to a maximum of 1.0.

As per the pre-consultation meeting with the City of Ottawa the time of concentration (T_c) used for pre-development shall be calculated using a time of concentration (T_c) not less than 10 minutes and post-development flows shall be calculated using a time of concentration (T_c) of 10 minutes.

6.2.1 Pre-Development Drainage

The existing site has been demonstrated as drainage area A1. The Pre-development Drainage Area Plan indicates the limits of the drainage area, see CP-20-0190 – PRE in Appendix 'E' of this report for more details. A summary of the pre-development runoff calculations can be found below.

Table 5 : Pre-Development Runoff Summary

Area ID	Drainage Area (ha)	5-Year Runoff Coefficient	100-Year Runoff Coefficient	T _c (min)	Unrestricted 5-year Peak Flow (L/s)	Unrestricted 100-year Peak Flow (L/s)
A1	0.10	0.88	0.98	10	26.72	50.92
Total	0.10				26.72	50.92

See CP-20-0190– PRE in Appendix 'E' and Appendix 'G' for calculations

6.2.2 Post-Development Drainage

The proposed site drainage limits are demonstrated on the Post-Development Drainage Area Plan. See CP-20-0190 – POST in Appendix 'F' of this report for more details. A summary of the Post-Development Runoff Calculations can be found below.

Table 6 : Post-Development Runoff Summary

Area ID	Drainage Area (ha)	5-Year Runoff Coefficient	100-Year Runoff Coefficient	T _c (min)	Unrestricted 5-year Peak Flow (L/s)	Unrestricted 100-year Peak Flow (L/s)
B1	0.03	0.68	0.77	10	5.02	9.66
B2	0.07	0.90	1.00	10	20.68	39.38
Total	0.10				25.70	49.04

See CP-20-0190 – POST in Appendix 'F' and Appendix 'G' for calculations

Runoff will be captured and conveyed to a new storm sewer network which will connect to the existing 900 mm storm sewer within Tremblay Road. In order to match pre-development flows, on site storage will be required. Storage will be provided on the roof of the proposed building. All other runoff will be directed to the ROWs. See Appendix 'G' for calculations.

6.3 Quantity Control

After discussing the stormwater management criteria for the site with City staff, the total post-development runoff for this site has been restricted to match the 5-year pre-development flow rates with a C value of 0.5. (See Appendix 'B' for pre-consultation notes). These values create the following allowable release rates and storage volumes for the development site.

Table 5: Allowable Release Rate

Area ID	Drainage Area (ha)	Runoff Coefficient	T _c (min)	Required Restricted Flow 5-year (L/s)
A1	0.10	0.50	10	15.16
Total	0.10			15.16

See Appendix 'G' for calculations

Reducing site flows will be achieved using Accutrol roof drains and will create the need for roof storage. Runoff from area B2 will be restricted as detailed in Table 6, below.

Table 6: Post-Development Restricted Runoff

Area ID	Drainage Area (ha)	5-Year Runoff Coefficient	100-Year Runoff Coefficient	T _c (min)	Restricted 5-year Peak Flow (L/s)	Restricted 100-year Peak Flow (L/s)
B1	0.03	0.68	0.77	10	5.02	9.66
B2	0.07	0.90	1.00	10	2.88	4.80
Total	0.10				7.90	14.46

See Appendix 'G' for calculations

Runoff from Area B2 will be restricted through Accutrol roof drains (or approved equivalent). Area B2 has eight roof drains that will restrict 5 and 100 year flows to 2.88 L/s and 4.80 L/s, respectively, resulting in a roof ponding depths of 30 mm and 50 mm. Table 6 details the required and provided storage volumes for the site. Runoff from area B1 will be unrestricted and will follow offsite toward the ROWs.

In the event that there is rainfall above the 100-year storm event, or a blockage within the storm network occurs, roof scuppers have been provided. The following table summarizes the storage requirements during the 5 and 100-year storm events and the provided storage volumes.

Table 7: Storage Summary

Drainage Area	Depth of Ponding (mm)	Storage Required (m ³)	Storage Available (m ³)	Depth of Ponding (mm)	Storage Required (m ³)	Storage Available (m ³)
	5-Year			100-Year		
B2	30	14.2	17.9	50	28.3	29.8

See Appendix 'G' for calculations

6.4 Quality Control

The development of this lot will employ Best Management Practices (BMP's) wherever possible. The intent of implementing stormwater BMP's is to ensure that water quality and quantity concerns are addressed at all stages of development. Lot level BMP's typically include temporary retention of the parking lot runoff, minimizing ground slopes and maximizing landscaped areas. Some of these BMP's cannot be provided for this site due to site constraints and development requirements.

It is recommended that the parking lot be swept regularly, particularly in the spring to remove sediment deposited from vehicles or winter maintenance. This will help to reduce sediment and salts entering the City storm sewer system.

7.0 SEDIMENT EROSION CONTROL

7.1 Temporary Measures

Before construction begins, temporary silt fence, straw bale or rock flow check dams will be installed at all-natural runoff outlets from the property. It is crucial that these controls be maintained throughout construction and inspection of sediment and erosion control will be facilitated by the Contractor or Contract Administration staff throughout the construction period.

Silt fences will be installed where shown on the final engineering plans, specifically along the downstream property limits. The Contractor, at their discretion or at the instruction of the City of Ottawa, RVCA or the Contract Administrator shall increase the quantity of sediment and erosion controls on-site to ensure that the site is operating as intended and no additional sediment finds its way off site. The rock flow, straw bale & silt fence check dams and barriers shall be inspected weekly and after rainfall events. Care shall be taken to properly remove sediment from the fences and check dams as required. Geosock is to be installed under the grates of all existing structures along the frontage of the site and any new structures immediately upon installation. The Geosock is to be removed only after all areas have been paved. Care shall be taken at the removal stage to ensure that any silt that has accumulated is properly handled and disposed of. Removal of silt fences without prior removal of the sediments shall not be permitted.

Although not anticipated, work through winter months shall be closely monitored for erosion along sloped areas. Should erosion be noted, the Contractor shall be alerted and shall take all necessary steps to rectify the

situation. Should the Contractor's efforts fail at remediating the eroded areas, the Contractor shall contact the RVCA to review the site conditions and determine the appropriate course of action. As the ground begins to thaw, the Contractor shall place silt fencing at all required locations as soon as ground conditions both warrant and permit. Please see the Site Grading and Drainage Plan for additional details regarding the temporary measures to be installed and their appropriate OPSD references.

8.0 SUMMARY

- A new 6 storey commercial and residential building will be constructed on the site located at 294 & 300 Tremblay Road.
- A new 200 mm diameter sanitary service and monitoring manhole will be installed and connected to the existing 225 mm diameter sewer within Avenue L.
- A new 150mm diameter water lateral will be extended from the existing 300 mm diameter main within Belfast Road and from the existing 150 mm diameter main within Avenue L to service the development.
- A storm service will be installed and will connect to the existing 900 mm storm sewer within Tremblay Road.
- As discussed with the City of Ottawa staff, the stormwater management design will ensure that the post-development flow rates are restricted to the 5-year pre-development flow rate calculated with a C value of 0.5.
- Storage for the 5- through 100-year storm events will be provided on the roof.
- BMPs are proposed to be implemented to help improve the quality of storm runoff.

9.0 RECOMMENDATIONS

Based on the information presented in this report, we recommend that City of Ottawa approve this Servicing and Stormwater Management Report in support of the proposed development at 300 Tremblay Road.

The sediment and erosion control plan outlined in Section 7.0 and detailed in the Grading and Drainage Plan notes are to be implemented by the contractor.

This report is respectfully being submitted for approval.



Brent Cuming, P.Eng.
Manager, Land Development
McIntosh Perry Consulting Engineers
T: 343.764.2102
E: b.cuming@mcintoshperry.com

Ryan Robineau
Civil Engineering Technician
McIntosh Perry Consulting Engineers
T: 613.714.6611
E: r.robineau@mcintoshperry.com

10.0 STATEMENT OF LIMITATIONS

This report was produced for the exclusive use of TM Project Management Inc. The purpose of the report is to assess the existing stormwater management system and provide recommendations and designs for the post-construction scenario that are in compliance with the guidelines and standards from the Ministry of the Environment and Climate Change, City of Ottawa and local approval agencies. McIntosh Perry reviewed the site information and background documents listed in Section 2.0 of this report. While the previous data was reviewed by McIntosh Perry and site visits were performed, no field verification/measures of any information were conducted.

Any use of this review by a third party, or any reliance on decisions made based on it, without a reliance report is the responsibility of such third parties. McIntosh Perry accepts no responsibility for damages, if any, suffered by any third party as a result of decisions or actions made based on this review.

The findings, conclusions and/or recommendations of this report are only valid as of the date of this report. No assurance is made regarding any changes in conditions subsequent to this date. If additional information is discovered or becomes available at a future date, McIntosh Perry should be requested to re-evaluate the conclusions presented in this report, and provide amendments, if required.

APPENDIX A
SITE LOCATION MAP

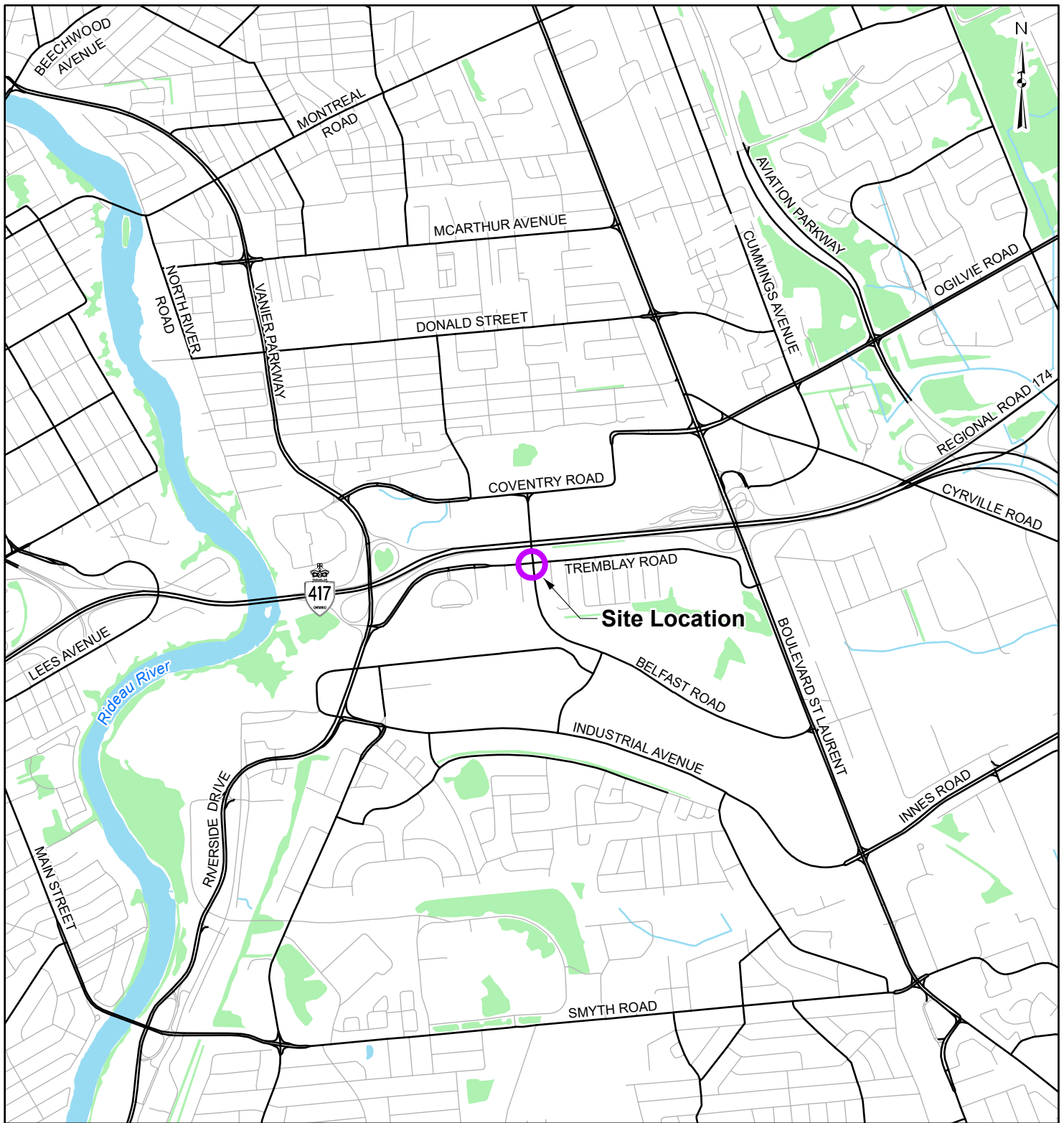

LEGEND

- Site Location
- Waterbody
- Local Road
- Wooded Area
- Major Road
- Watercourse

REFERENCE

GIS data provided by the Ontario Ministry of Natural Resources and Forestry, 2020.

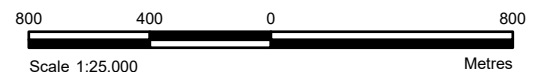

CLIENT:		PROJECT 1 STUDIO	
PROJECT:		300 TREMBLAY ROAD	
TITLE:		SITE LOCATION	
PROJECT NO: CP-20-0190		FIGURE:	
Date	Sep., 29, 2020	1	
GIS	EU		
Checked By	CH		

McINTOSH PERRY
 115 Walgreen Road, RR3, Carp, ON K0A1L0
 Tel: 613-836-2184 Fax: 613-836-3742
 www.mcintoshperry.com

APPENDIX B
CITY OF OTTAWA PRE-CONSULTATION NOTES

Development Review – Pre-application consultation Checklist (Municipal Servicing)

Date: 2020-Apr-30

Site Location: 300 Tremblay

Type of Development: Residential (townhomes, stacked, singles, apartments),
 Office Space, Commercial, Retail, Institutional, Industrial,
Other: N/A

Assigned Planner: Sarah Ezzio/Sean Moore

Project Manager: Adam Baker/Cody Oram

Water

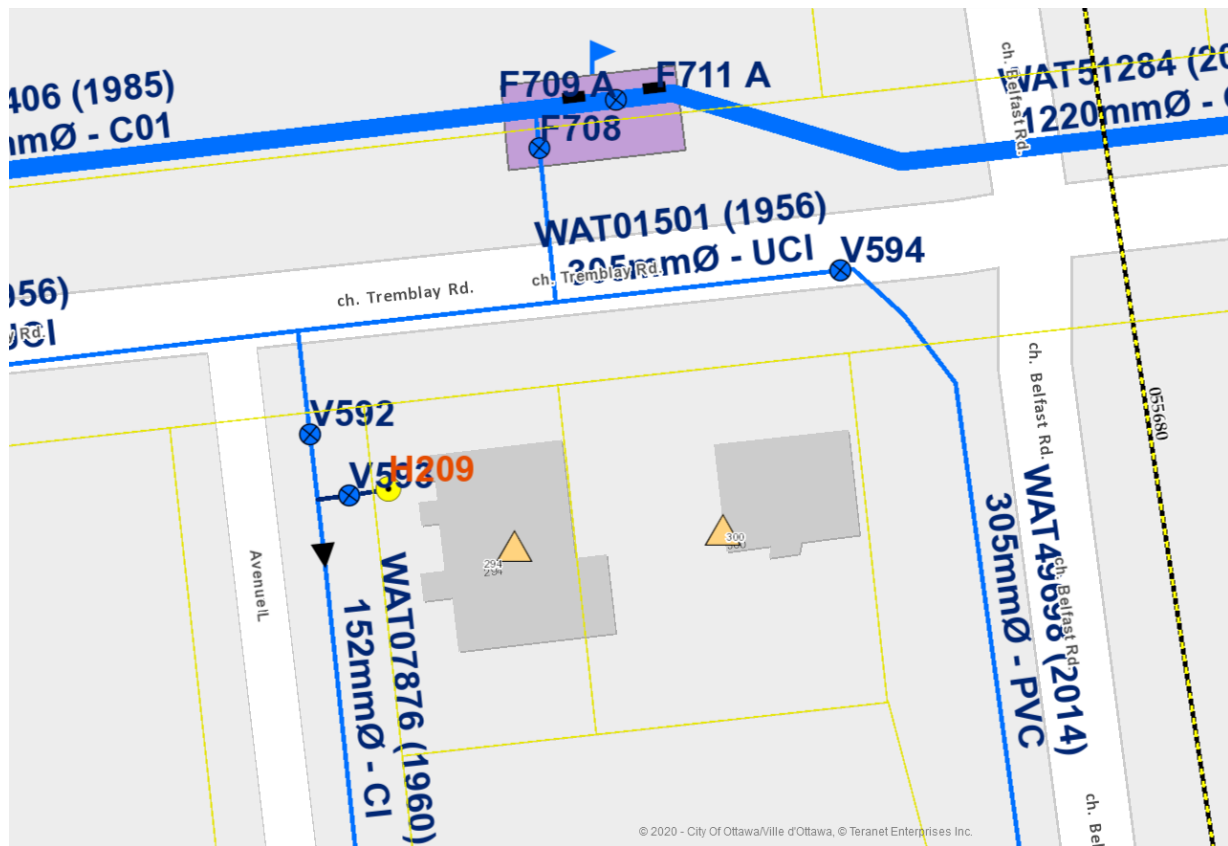

District Plan No. CN2

Water Frontage Fees (\$190.00 per metre) – N/A

Connection Point:

- Tremblay Road – 305mm unlined cast iron watermain
- Avenue L – 152mm cast iron watermain
- Belfast Road – 305mm PVC watermain

Development Review – Pre-application consultation Checklist (Municipal Servicing)

Please note - Service areas with a basic day demand greater than 50 m³/day shall be connected with a minimum of two watermains, separated by an isolation valve, to avoid the creation of a vulnerable service area. Individual residential facilities with a basic day demand greater than 50 m³/day shall be connected with a minimum of two water services, separated by an isolation valve, to avoid the creation of a vulnerable service area.

Sanitary Sewers

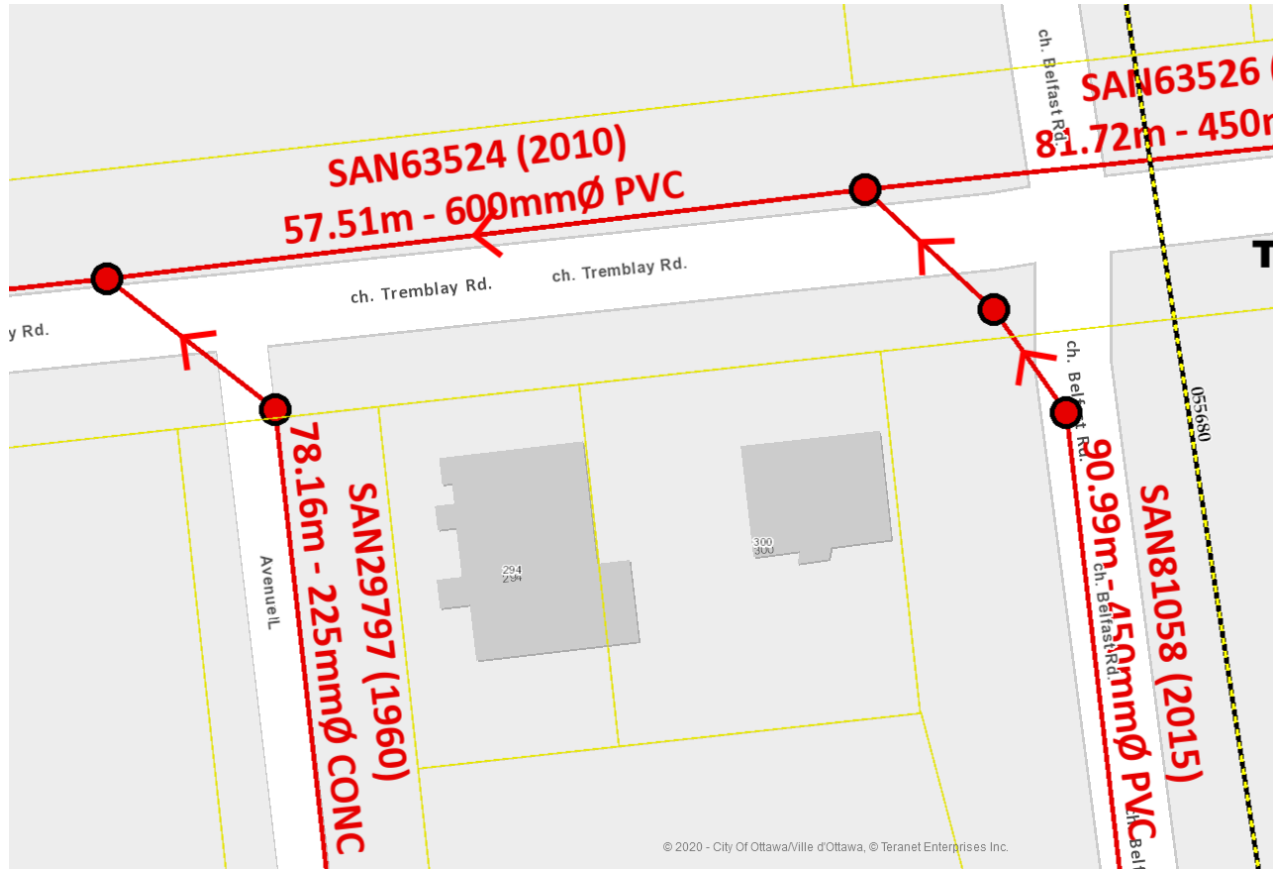

Connection Point:

- Tremblay Road* – 600mm PVC sewer
- Avenue L* – 225mm concrete sewer
- Belfast Road* - 450mm concrete sewer

There are sanitary flow constraints in this sanitary catchment area. The proposed flow calculations have been received and we will follow up directly to confirm the permissible flows for this property.

Due to the age of sewers within Avenue L, condition assessments will be required as part of the submission.

Storm Sewers

Development Review – Pre-application consultation Checklist (Municipal Servicing)

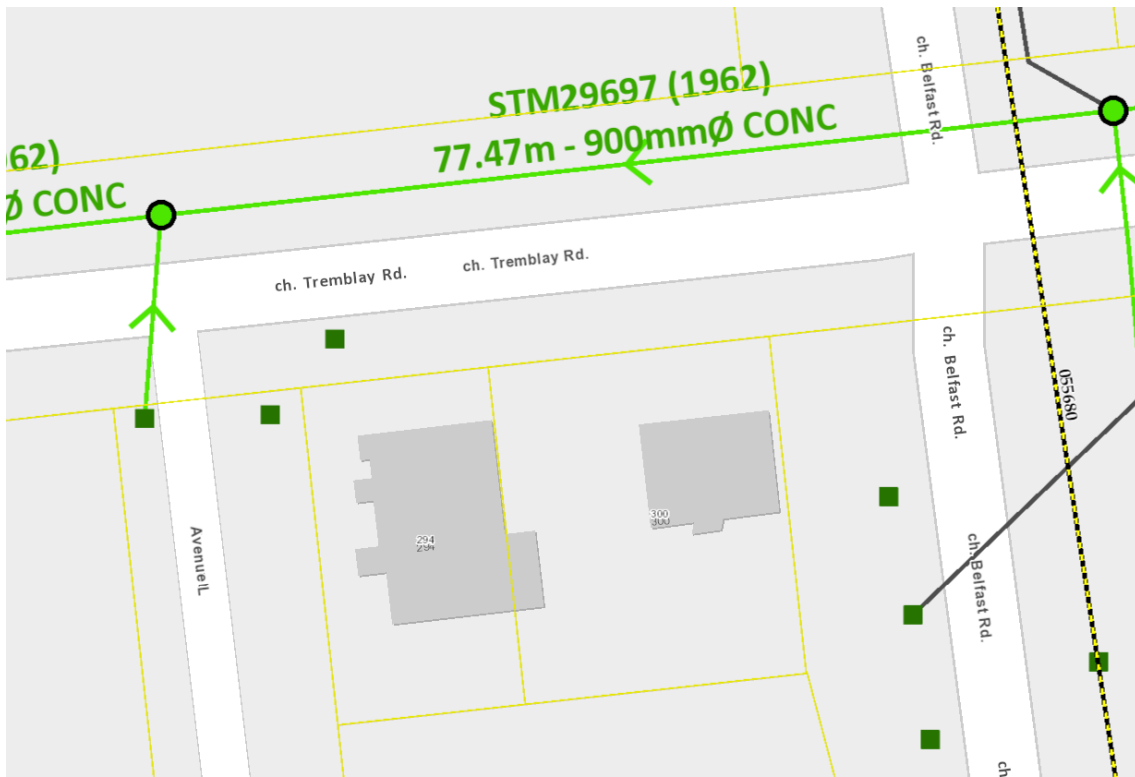

Connection Point:

Tremblay Road – 900mm concrete storm sewer

Sediment and Erosion Control Requirements: This area is located within the Rideau River – Rideau Falls catchment area. As such, lot level sediment and erosion control requirements will be provided by the Rideau Valley Conservation Authority.

The Stormwater Management Criteria, for the subject site, if connecting to public services, is to be based on the following:

- i. The 5-yr storm event using the IDF information derived from the Meteorological Services of Canada rainfall data, taken from the MacDonald Cartier Airport, collected 1966 to 1997.
- ii. The pre-development runoff coefficient or a maximum equivalent **'C' of 0.50** whichever is less (§ 8.3.7.3).
- iii. A calculated time of concentration (Cannot be less than 10 minutes).
- iv. Flows to the storm sewer in excess of the 5-year storm release rate, up to and including the 100-year storm event, must be detained on site.

Submission documents must address/discuss:

Development Review – Pre-application consultation Checklist (Municipal Servicing)

- Boundary conditions (civil consultant must request boundary conditions from the City’s assigned Project Manager, Development Review)
 - Water boundary condition requests must include the location of the service and the expected loads required by the proposed development. Please provide all the following information:
 - Location of service
 - Type of development and the amount of fire flow required (as per FUS, 1999).
 - Average daily demand: ___ l/s.
 - Maximum daily demand: ___ l/s.
 - Maximum hourly daily demand: ___ l/s.
- Fire protection (Fire demand, Hydrant Locations)
- a water meter sizing questionnaire [water card] will have to be completed prior to receiving a water permit (water card will be provided post approval)
- a construction management plan is required if crossing 400mm Ø watermain during construction
 - The temporary watermain support shall be as per City of Ottawa Standards, where applicable. A structural support detail drawing prepared by a Structural Engineer licensed in the Province of Ontario is required in all other cases.
 - The permanent support detail drawing shall be provided.
 - Backfill detail drawing shall be provided.
 - Watermain isolation valve locations shall be provided.
 - The operation status of the watermain must be specified (i.e. operational, throttled, or shutdown). The proposed throttle or shutdown of the watermain shall provide reasoning and approved on exceptional basis only.

Note: The proposed design detail will be coordinated with the Water Distribution Branch for comment.

Ministry of Environment, Conservation and Parks (MECP)

All development applications should be considered for an Environmental Compliance Approval, under MECP regulations.

- a. Consultant determines if an approval for sewage works under Section 53 of OWRA is required. Consultant determines what type of application is required and the City’s project manager confirms. (If the consultant is not clear if an ECA is required, they will work with the City to determine what is required. If unclear or there is a difference of opinion the City Project Manager will coordinate requirements with MECP).
- b. The project will be either transfer of review (standard), transfer of review (additional), direct submission, or exempt as per O. Reg. 525/98.
- c. Pre-consultation is not required if applying for standard or additional works (schedule A of the Agreement) under Transfer Review.
- d. Pre-consultation with local District office of MECP is recommended for direct submission.
- e. Consultant completes an MECP request form for a pre-consultation. Sends request to moeccottawasewage@ontario.ca.

NOTE: Site Plan Approval, or Draft Approval, is required before any Ministry of the Environment and Climate Change (MOECC) application is sent

Are there are Capital Works Projects scheduled that will impact the application? Yes No

Belfast Road – New bike route

Exterior Site Lighting:

If yes, require certification by a licensed professional engineer confirming the design complies with the following:

The location of the fixtures, fixture type (make, model, part number and the mounting height) must be shown on one of the approved plans.

Development Review – Pre-application consultation Checklist (Municipal Servicing)

1. Lighting must be designed only using fixtures that meet the criteria for Full Cut-off classification, as recognized by the Illuminating Engineering Society of North America (IESNA or IES), and
 2. It must result in minimal light spillage onto adjacent properties. As a guideline, 0.5 foot-candle is normally the maximum allowable spillage.
-

Refer to following table for the list of required supporting plans and studies required for the infrastructure component of your submission.

APPLICANT'S STUDY AND PLAN IDENTIFICATION LIST – SPA – MUNICIPAL SERVICING



Legend:

The letter **S** indicates that the study or plan is required with application submission.

The letter **M** indicates that the study or plan may be required with application submission.

For information on preparing required studies and plans refer to:

<http://ottawa.ca/en/development-application-review-process-0/guide-preparing-studies-and-plans>

S/A	ENGINEERING		S/M
S	1. Site Servicing Plan	2. Site Servicing Study	S
S	3. Grade Control and Drainage Plan	4. Geotechnical Study	S
	5. Composite Utility Plan	6. Groundwater Impact Study	
	7. Servicing Options Report (Urban)	8. Wellhead Protection Study	
	9. Community Transportation Study and/or Trans. Impact Study / Brief	10. Erosion and Sediment Control Plan / Brief	S
S	11. Storm water Management Report / Brief	12. Hydro-geological and Terrain Analysis (Not for Commercial/Industrial)	
	13. Hydraulic Water main Analysis	14. Noise Control and Vibration Study	S
	15. Roadway Modification Design Plan	16. Confederation Line Proximity Study	

SURVEYOR'S REAL PROPERTY REPORT WITH TOPOGRAPHIC DETAILS
PART 1 - PLAN SHOWING
LOTS 79, 80, 81, 82, AND 83
REGISTERED PLAN No. 320
CITY OF OTTAWA
J.D. BARNES LIMITED

SITE PLAN SYMBOLS LEGEND

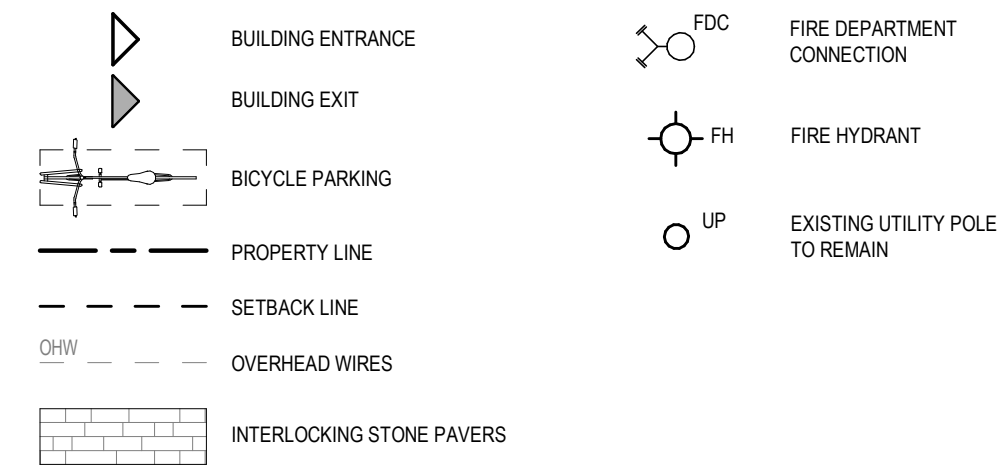

SITE PLAN SYMBOLS
SCALE: N.T.S

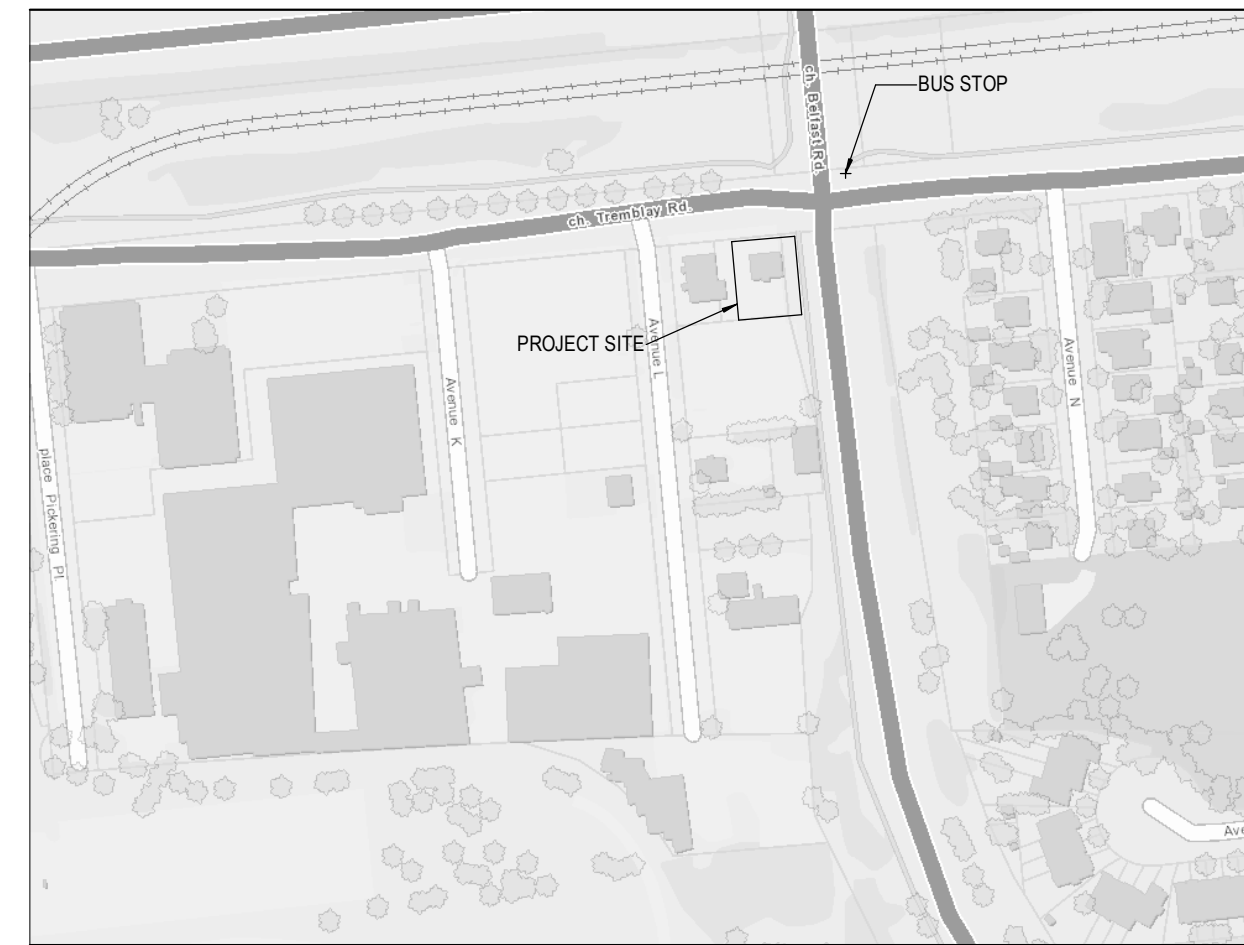

2 LOCATION PLAN
SP-01 SCALE: N.T.S

- GENERAL ARCHITECTURAL NOTES:
- This drawing is the property of the Architect and may not be reproduced or used without the expressed consent of the Architect.
 - Drawings are not to be scaled. The Contractor is responsible for checking and verifying all levels and dimensions and shall report all discrepancies to the Architect and obtain clarification prior to commencing work.
 - Upon notice in writing, the Architect will provide written clarification or supplementary information regarding the intent of the Contract Documents.
 - The Architectural drawings are to be read in conjunction with all other Contract Documents including Project Manuals and the Structural, Mechanical and Electrical Drawings.
 - Positions of exposed or finished Mechanical or Electrical devices, fittings and fixtures are indicated on the Architectural Drawings. Locations shown on the Architectural Drawings shall govern over Mechanical and Electrical Drawings. Mechanical and Electrical items not clearly located will be located as directed by the Architect.
 - These documents are not to be used for construction unless specifically noted for such purpose.

TCU
TC UNITED GROUP

NOTE: SNOW TO BE TRUCKED OFF SITE

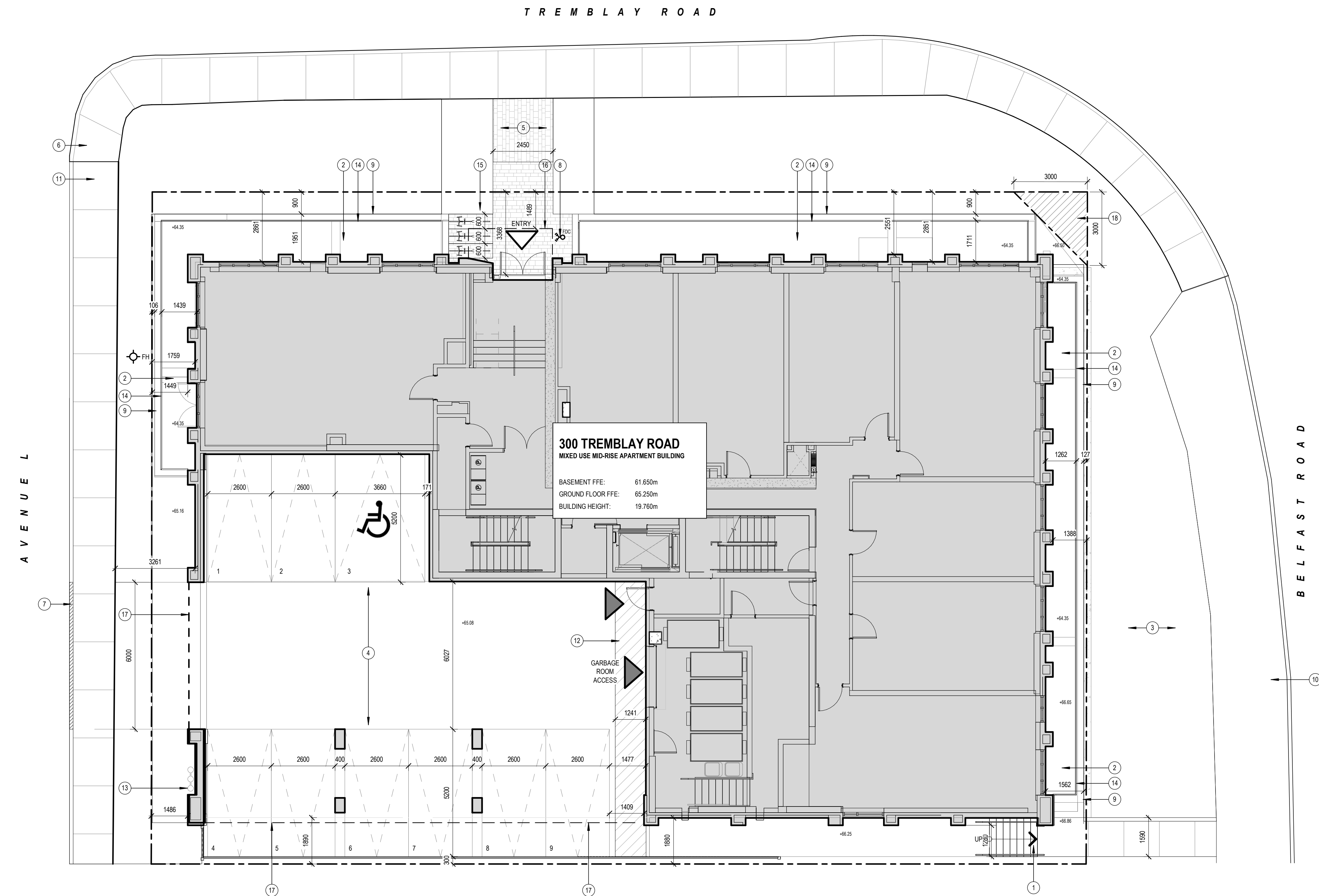

KEYNOTE LEGEND:

- | | |
|--------------------------------|---------------------------|
| 1 CONCRETE WALKWAY | 13 GAS BLOW-OFF STATION |
| 2 WINDOW WELL | 14 PAINTED STEEL GUARD |
| 3 SOFT LANDSCAPING | 15 VISITOR BIKE PARKING |
| 4 ASPHALT | 16 LINE OF CANOPY ABOVE |
| 5 INTERLOCKING CONCRETE PAVERS | 17 LINE OF BUILDING ABOVE |
| 6 EXISTING CONCRETE SIDEWALK | 18 CORNER SITE TRIANGLE |
| 7 DEPRESSED CURB | |
| 8 FIRE DEPARTMENT CONNECTION | |
| 9 RETAINING WALL | |
| 10 EXISTING MULTI-USE PATHWAY | |
| 11 NEW CONCRETE SIDEWALK | |
| 12 PAINTED LINES | |

Site Statistics

Current Zoning Designation:	TD1
Lot Width:	38.16m
Total Lot Area:	1046.6m ²
Gross Floor Area:	3985.36m ²
Building Area:	796.892m ²
Floor Space Index:	3.81
Number of Units:	100 units

Proposed Development - Mixed-Use mid-Rise Apartment Building

Zoning Mechanism	Required	Provided
Minimum Lot Area 195(9)	No Minimum	0.10 ha
Minimum Lot Width 195(9)	No Minimum	38.16m
Min. Front Yard Setback 195(9)(v)	0.5m	2.8m
Corner Side Yard Setback 195(9)(v)	0.5m	1.3m East 1.7m West
Min. Rear Yard Setback 195(9)(ii)	No Minimum	1.9m
Maximum Building Height 199(14)(e)	20m	19.890m
Parking Space Rates (Residents) 101 (Sch. 1A - Area Z)	0 Spaces Section 101(2)	0 Spaces
Minimum Visitor Parking Rates 102 (Sch. 1A - Area Z)	9 Spaces 0 spaces for first 12 units - Section 102(2) 0.1 spaces / unit for 88 units - Table 102	9 Spaces
Parking Space Rates (Retail) 101 (Sch. 1A - Area Z)	0 Spaces Section 101(2)	0 Spaces
Bicycle Parking Rates (Residents) Table 111A (Sch. 1 - Area B)	50 Spaces 0.5 spaces / unit for 100 units [111A(b)] (f)	51 Spaces
Bicycle Parking Rates (Retail) Table 111A (Sch. 1 - Area B)	0 Spaces 1 space / 250m ² x 100m ² [111A(e)]	0 Spaces
Total Amenity Area Table 137(4)(i)	600m ² 6m ² / unit for 100 units	656m ²
Communal Amenity Area Table 137(4)(iii)	300m ² Min. 50% of Total Amenity Area	522m ² Roof Top Terrace

3 SITE & PROJECT STATISTICS
SP-01 SCALE: N.T.S

- 7 ISSUED FOR TENDER 2023-07-05
3 RE-ISSUED FOR BUILDING PERMIT 2023-05-25
2 ISSUED FOR COORDINATION 2023-05-03
1 ISSUED FOR BUILDING PERMIT 2021-06-12

ISSUE RECORD

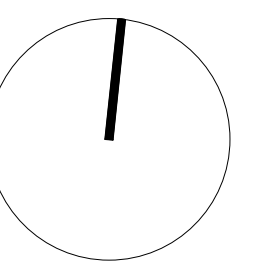

project1
studio

Project1 Studio Incorporated
[613.884.9339] | mail@project1studio.ca

300 TREMBLAY

300 Tremblay Road
Ottawa, ON

PROJ SCALE DRAWN REVIEWED
2008 NOTED DFE RMK

SITE PLAN

SP-01

1 SITE PLAN
SP-01 SCALE: 1 : 100

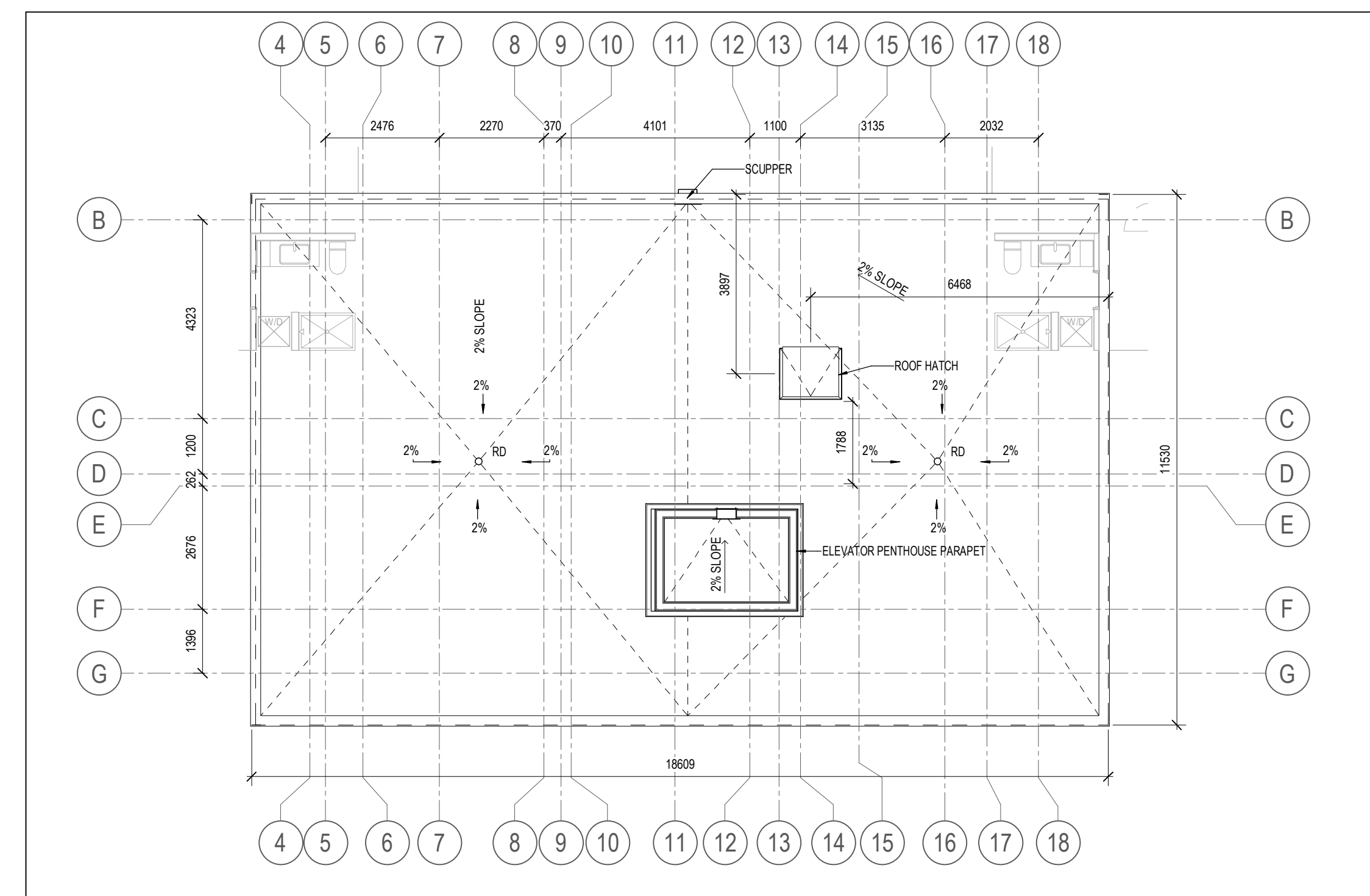

1 T.O. UPPER ROOF
A107 SCALE: 1 : 100

- GENERAL FLOOR PLAN NOTES**
- UNLESS NOTED OTHERWISE, DOOR FRAMES ARE TO BE INSTALLED 100mm FROM THE ADJACENT PERPENDICULAR PARTITION.
 - UNLESS NOTED OTHERWISE, ALL DIMENSIONS MARKED CLEAR OR CLR SHALL BE MAINTAINED AND SHALL ALLOW FOR THICKNESS OF THE COMPLETE WALL ASSEMBLY INCLUDING FINISHES. SHALL BE ACCURATELY MAINTAINED AND SHALL NOT VARY MORE THAN ±3mm WITHOUT WRITTEN CONSENT FROM THE ARCHITECT.
 - UNLESS NOTED OTHERWISE, DOOR FRAMES ARE TO BE INSTALLED 100mm FROM THE ADJACENT PERPENDICULAR PARTITION.
 - UNLESS NOTED OTHERWISE, ALL EQUIPMENT IS SUPPLIED AND INSTALLED BY CONTRACTOR. CONTRACTOR TO COORDINATE AND SUPPLY REQUIRED SERVICES FOR EQUIPMENT.
 - CONTRACTOR RESPONSIBLE TO COORDINATE DIMENSIONS OF OPENINGS WITH SPECIFICATIONS FOR EQUIPMENT SUPPLIED AND INSTALLED BY OTHERS.
 - PROVIDE TILE BACKER BOARD AND WATER-RESISTANT GYPSUM BOARD IN WASHROOMS AS NOTED IN GENERAL NOTES #19 & #20 ON A800 - A804.
 - RESERVED
 - MAXIMUM DISTANCE OF 5100mm BETWEEN CONTROL JOINTS IN GYPSUM SURFACES.
 - CAULK AND SEAL AT ALL MECHANICAL AND ELECTRICAL PENETRATIONS.
 - ALL PARTITIONS THAT EXTEND FROM SLAB TO SLAB ARE TO BE ALIGNED WITH GEOMETRY OF THE SLABS IN ORDER TO ENSURE THAT THE ENTIRE PERIMETER BE APPROPRIATELY SEALED AS REQUIRED TO ATTAIN THE NECESSARY FIRE RESISTANCE RATING AND ACOUSTICAL PERFORMANCE.
 - SUPPLY AND INSTALL NON-COMBUSTIBLE BLOCKING AND NAULERS FOR ALL PARTITIONS SUPPORTING ELECTRICAL PANELS, ELECTRICAL & MECHANICAL DEVICES, MILLWORK, SHELVING, SIGNAGE, ACCESSORIES, EQUIPMENT, ETC.

- GENERAL ARCHITECTURAL NOTES:**
- This drawing is the property of the Architect and may not be reproduced or used without the expressed consent of the Architect.
 - Drawings are not to be scaled. The Contractor is responsible for checking and verifying all levels and dimensions and shall report all discrepancies to the Architect and obtain clarification prior to commencing work.
 - Upon notice in writing, the Architect will provide written clarification or supplementary information regarding the intent of the Contract Documents.
 - The Architectural drawings are to be read in conjunction with all other Contract Documents including Project Manuals and the Structural, Mechanical and Electrical Drawings.
 - Positions of exposed or finished Mechanical or Electrical devices, fittings and fixtures are indicated on the Architectural Drawings. Locations shown on the Architectural Drawings shall govern over Mechanical and Electrical Drawings. Mechanical and Electrical items not clearly located will be located as directed by the Architect.
 - These documents are not to be used for construction unless specifically noted for such purpose.

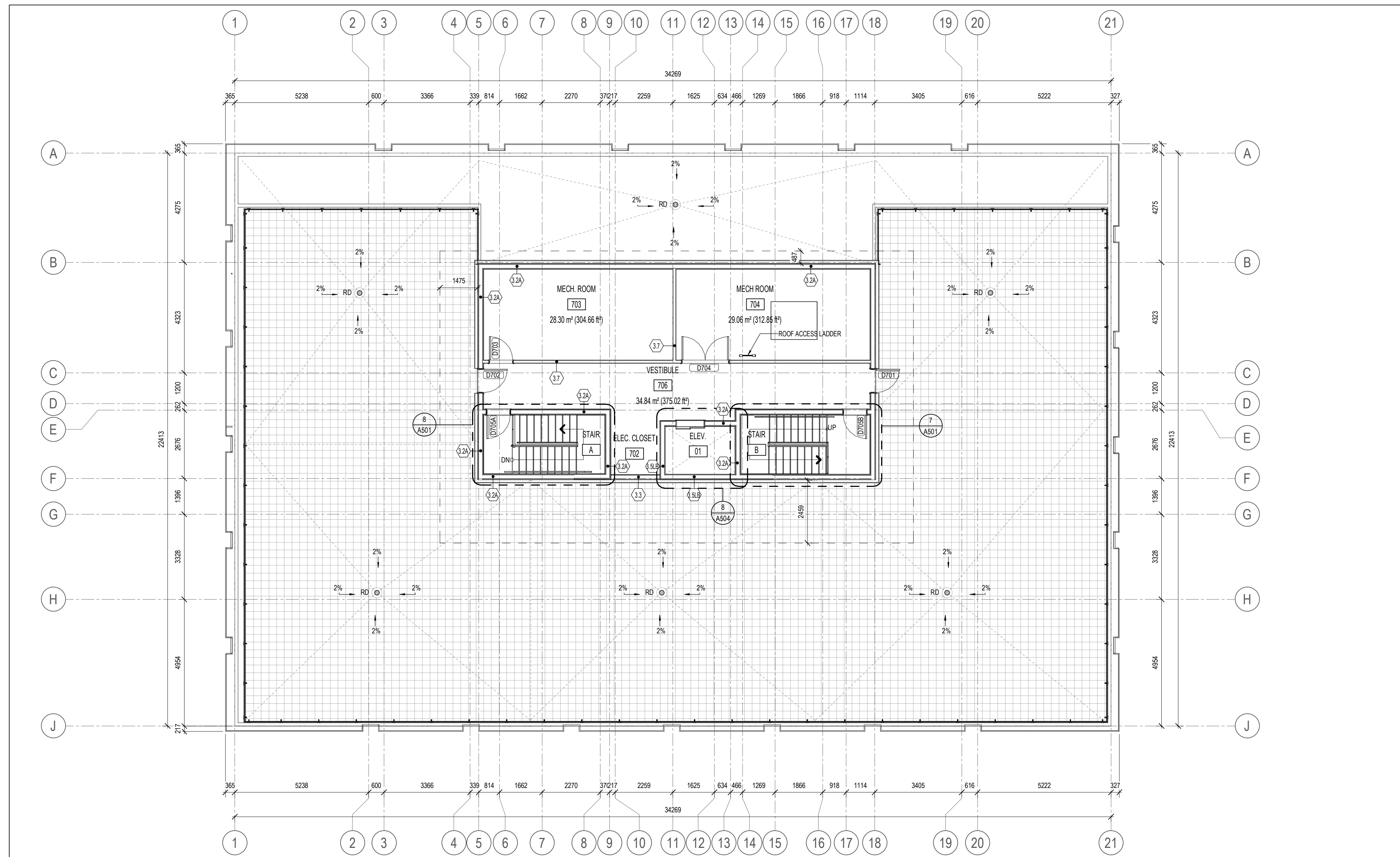

2 T.O. ROOF
A107 SCALE: 1 : 100

- KEYNOTE LEGEND - FLOOR PLANS**
- P5 RECESSED MAIL BOXES, REFER TO SPEC.
 - P6 METAL SHELVING UNITS FOR PARCEL STORAGE, BY CLIENT.
 - P7 PROPERTY LINE
 - P14 FIRE DEPARTMENT CONNECTION, REFER TO MECH.
 - P19 TRI-SORTER, TBC.
 - P28 FLOOR DRAIN, REFER TO MECH.

ISSUE RECORD

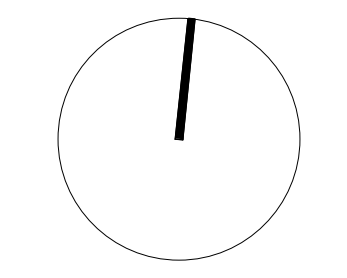

project1 studio
Project1 Studio Incorporated
[613.884.3939] | mail@project1studio.ca

300 TREMBLAY
300 Tremblay Road
Ottawa, ON

PROJ	SCALE	DRAWN	REVIEWED
2008	NOTED	GS	Checker

ROOFTOP TERRACE

A107

NOTES
 BEARINGS ARE WTM GRID, AND DERIVED FROM GLOBAL NAVIGATION SATELLITE SYSTEMS (GNSS) BY REAL TIME NETWORK (RTN) OBSERVATIONS, NAD 83, (CSRS) (2010).
 DISTANCES ARE GROUND.
 COMPLIANCE WITH ONTARIO BUILDING CODE SETBACK REQUIREMENTS ARE NOT VERIFIED BY THIS SURVEY.

PART 2 - SURVEY REPORT
 - DESCRIPTION
 LOTS 79, 80, 81, 82 AND 83 ON REGISTERED PLAN No. 320, BEING ALL OF PINS 04256-0011 (LT) AND 04256-0012 (LT), IN THE CITY OF OTTAWA.
 - REGISTERED EASEMENTS AND/OR RIGHTS-OF-WAY
 NONE
 - BOUNDARY FEATURES
 NOTE LOCATION OF THE OVERHEAD ELECTRICAL CABLE ALONG THE NORTHERLY AND WESTERLY LIMIT OF THE SUBJECT PROPERTY

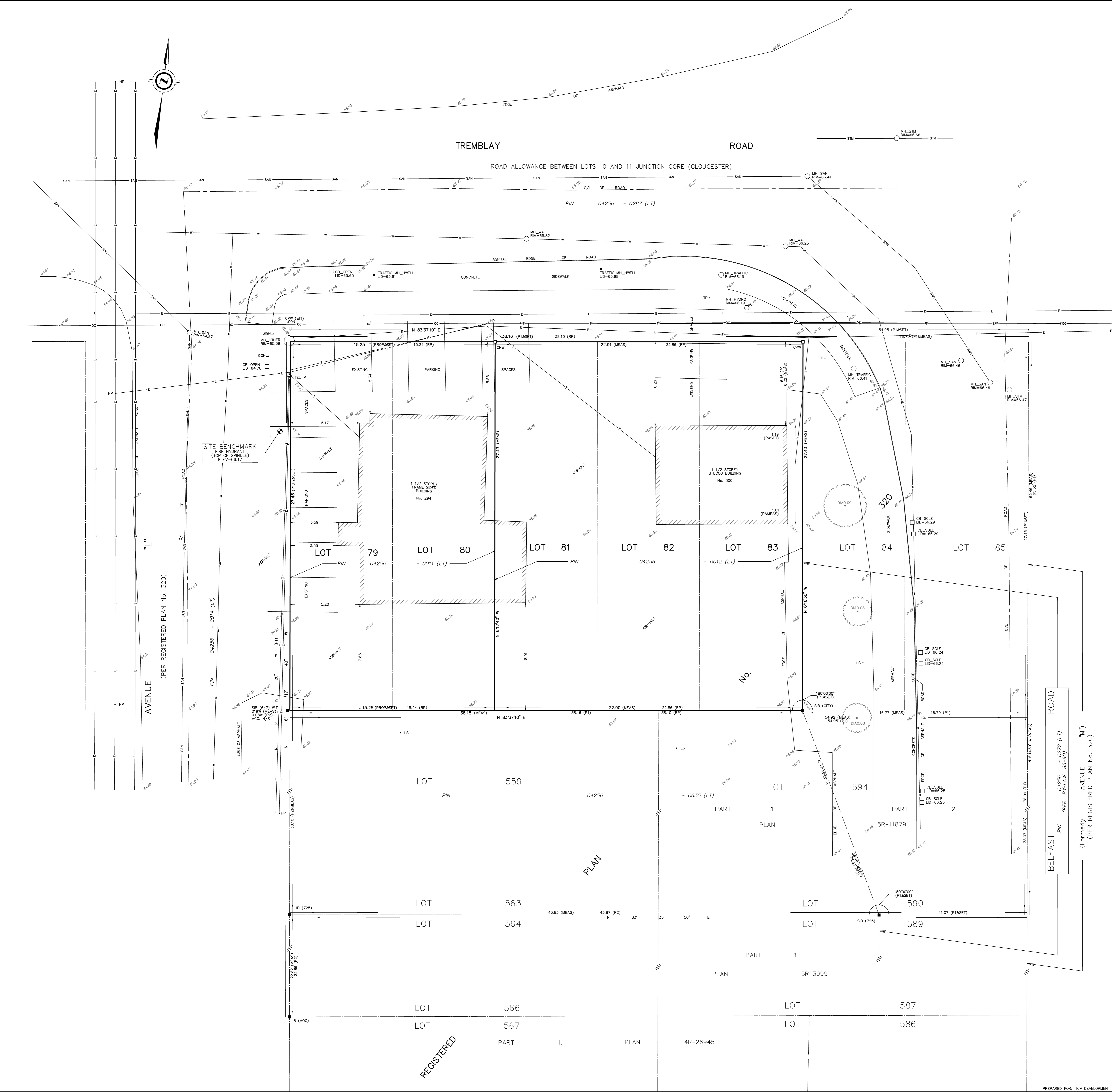

- LEGEND**
- DENOTES SURVEY MONUMENT FOUND
 - DENOTES SURVEY MONUMENT SET
 - SIB DENOTES STANDARD IRON BAR
 - IB DENOTES IRON BAR
 - CPW DENOTES CONCRETE PIN AND WASHER
 - WT DENOTES WITNESS
 - MEAS DENOTES MEASURED
 - ACC DENOTES ACCEPT
 - PROP DENOTES PROPORTION
 - OJ DENOTES ORIGIN UNKNOWN
 - RP DENOTES REGISTERED PLAN 320
 - P DENOTES SURVEYOR'S REAL PROPERTY REPORT BY S.E. & H.R. FARLEY, O.L.S., DATED JUNE 6, 1999
 - P1 DENOTES PLAN 5R-11879
 - P2 DENOTES SURVEYOR'S REAL PROPERTY REPORT BY ANNIS, O'SULLIVAN, VOLLEBEKK LTD., DATED OCTOBER 15, 2004
 - 647 DENOTES H.R. FARLEY, O.L.S.
 - 725 DENOTES R.W. ARNETT, O.L.S.
 - CITY DENOTES CITY OF OTTAWA
 - AOG DENOTES ANNIS, O'SULLIVAN, VOLLEBEKK LTD.
- N=NORTH / S=SOUTH / E=EAST / W=WEST

- TOPOGRAPHIC LEGEND**
- C/L DENOTES CENTERLINE
 - HP DENOTES HYDRO POLE
 - LS DENOTES LIGHT STANDARD
 - TP DENOTES TRAFFIC POLE
 - TEL_P DENOTES TELEPHONE POLE
 - MH_WAT DENOTES WATER MANHOLE
 - MH_HYDRO DENOTES HYDRO MANHOLE
 - MH_STM DENOTES STORM MANHOLE
 - MH_TRAFFIC DENOTES TRAFFIC MANHOLE
 - MH_SAN DENOTES SANITARY MANHOLE
 - TRAFFIC_MH_HWELL DENOTES TRAFFIC HANDWELL
 - CB_SOLE DENOTES SINGLE CATCH BASIN
 - CB_OPEN DENOTES OPEN CATCH BASIN
 - E DENOTES OVERHEAD HYDRO CABLE
 - OC DENOTES OVERHEAD UTILITY CABLE
 - T DENOTES OVERHEAD TELEPHONE CABLE
 - SAN DENOTES UNDERGROUND SANITARY SEWER
 - STM DENOTES UNDERGROUND STORM SEWER
 - W DENOTES UNDERGROUND WATER LINE

ELEVATION NOTE:
 1. ELEVATIONS ARE GEODETIC AND WERE ESTABLISHED USING GLOBAL NAVIGATION SATELLITE SYSTEMS (GNSS) EQUIPMENT TO ESTABLISH ELLIPSOIDAL HEIGHTS. ELLIPSOIDAL HEIGHTS WERE TRANSFORMED TO CANADIAN DATUM (GEODETIC) USING THE FEDERAL HT 2.0 HEIGHT TRANSFORMATION MODEL.
 2. IT IS THE RESPONSIBILITY OF THE USER OF THIS INFORMATION TO VERIFY THAT THE SITE BENCHMARKS HAVE NOT BEEN ALTERED OR DISTURBED AND THAT ITS RELATIVE ELEVATION AND DESCRIPTION AGREES WITH THE INFORMATION SHOWN ON THIS DRAWING.

SURVEYOR'S CERTIFICATE
 I CERTIFY THAT:
 1. THIS SURVEY AND PLAN ARE CORRECT AND IN ACCORDANCE WITH THE SURVEYS ACT, THE SURVEYORS ACT AND THE REGULATIONS MADE UNDER THEM.
 2. THE SURVEY WAS COMPLETED ON JULY 30th, 2020.
 DATE: AUGUST 7th, 2020

 J.D. BARNES LIMITED
 SURVEYOR

J.D. BARNES LIMITED
 SURVEYING MAPPING GIS
 LAND INFORMATION SPECIALISTS
 43 STANICE DRIVE, SUITE 103, KANATA, ON K2K 2A9
 T: (613) 731-7244 F: (613) 354-8609 www.jdbarnes.com

DRAWN BY: RP CHECKED BY: GZ REFERENCE NO.: 20-10-043-00
 PLOTTED: 8/7/2020 DATE: 07/24/20

PREPARED FOR: TCY DEVELOPMENT CORP. FILE: G:\20-10-043\00\Drawings\SRPP-TOPO\201004300SRPP1TOPO.dgn

APPENDIX C
WATERMAIN CALCULATIONS

Ryan Robineau

From: Adams, Reed <reed.adams@ottawa.ca>
Sent: August 18, 2023 10:28 AM
To: Ryan Robineau
Cc: Curtis Melanson
Subject: RE: Pre-Consultation Follow-up - 294 & 300 Tremblay - PC2023-0154
Attachments: 300 Tremblay Road August 2023.pdf

Hi Ryan,

The following are boundary conditions, HGL, for hydraulic analysis at 300 Tremblay Road (zone 1E) assumed to be connected to a new 203 mm watermain that connects Belfast Road and Avenue L (see attached PDF for location).

Min HGL: 110.6 m (Avenue L Connection), 110.3 m (Belfast Connection)

Max HGL: 118.9 m (Both Connections)

Max Day + Fire Flow (50 L/s): 114.1 m (Avenue L Connection), 114.3 m (Belfast Connection)

These are for current conditions and are based on computer model simulation.

Disclaimer: The boundary condition information is based on current operation of the city water distribution system. The computer model simulation is based on the best information available at the time. The operation of the water distribution system can change on a regular basis, resulting in a variation in boundary conditions. The physical properties of watermains deteriorate over time, as such must be assumed in the absence of actual field test data. The variation in physical watermain properties can therefore alter the results of the computer model simulation.

Thanks,

Reed

From: Adams, Reed <reed.adams@ottawa.ca>
Sent: August 11, 2023 9:26 AM
To: Ryan Robineau <r.robineau@mcintoshperry.com>
Cc: Curtis Melanson <c.melanson@mcintoshperry.com>; Shillington, Jeffrey <jeff.shillington@ottawa.ca>
Subject: RE: Pre-Consultation Follow-up - 294 & 300 Tremblay - PC2023-0154

Thanks Ryan, I've passed this along to our water group to be processed.

Reed

From: Ryan Robineau <r.robineau@mcintoshperry.com>
Sent: August 10, 2023 4:22 PM
To: Adams, Reed <reed.adams@ottawa.ca>
Cc: Curtis Melanson <c.melanson@mcintoshperry.com>; Shillington, Jeffrey <jeff.shillington@ottawa.ca>
Subject: RE: Pre-Consultation Follow-up - 294 & 300 Tremblay - PC2023-0154

CAUTION: This email originated from an External Sender. Please do not click links or open attachments unless you recognize the source.

ATTENTION : Ce courriel provient d'un expéditeur externe. Ne cliquez sur aucun lien et n'ouvrez pas de pièce jointe, excepté si vous connaissez l'expéditeur.

Hello Reed,

It appears as though the boundary condition request for 300 Tremblay was not forwarded to you. Can you please provide boundary conditions for connections to the 152mm CI watermain within Avenue L and the 305mm PVC watermain within Belfast Road (see attached connection figure).

- The estimated fire flow is 3,000 L/min based on the 2020 FUS
- Average daily demand: 0.48 L/s
- Maximum daily demand: 1.67 L/s
- Maximum hourly daily: 2.51 /s

Attached is a map showing the proposed connection location along with the calculations prepared for the demands listed above.

Please let me know if you have any questions.

Regards,

Boundary Conditions for 300 Tremblay Road



Legend

Public

Private

Avenue L Connection

Belfast Connection

McINTOSH PERRY

CP-20-0190 - 300 Tremblay - Water Demands

Project:	300 Tremblay
Project No.:	CP-20-0190
Designed By:	RRR
Checked By:	RDF
Date:	July 28, 2023
Site Area:	0.10 gross ha

<u>Residential</u>	NUMBER OF UNITS		UNIT RATE	
Single Family		homes	3.4	persons/unit
Semi-detached		homes	2.7	persons/unit
Townhouse		homes	2.7	persons/unit
Studio Apartment	77	units	1.4	persons/unit
1 Bedroom Apartment	23	units	1.4	persons/unit
2 Bedroom Apartment		units	2.1	persons/unit
3 Bedroom Apartment		units	3.1	persons/unit
Average Apartment		units	1.8	persons/unit

Total Population 140 persons

<u>Commercial/Ammeinty</u>	728 m2
<u>Industrial - Light</u>	m2
<u>Industrial - Heavy</u>	m2

AVERAGE DAILY DEMAND

DEMAND TYPE	AMOUNT	UNITS	
Residential	280	L/c/d	
Industrial - Light	35,000	L/gross ha/d	
Industrial - Heavy	55,000	L/gross ha/d	
Shopping Centres	2,500	L/(1000m ² /d)	
Hospital	900	L/(bed/day)	
Schools	70	L/(Student/d)	
Trailer Park with no Hook-Ups	340	L/(space/d)	
Trailer Park with Hook-Ups	800	L/(space/d)	
Campgrounds	225	L/(campsite/d)	
Mobile Home Parks	1,000	L/(Space/d)	
Motels	150	L/(bed-space/d)	
Hotels	225	L/(bed-space/d)	
Tourist Commercial	28,000	L/gross ha/d	
Other Commercial	28,000	L/gross ha/d	
AVERAGE DAILY DEMAND	Residential	0.45	L/s
	Commercial/Industrial/ Institutional	0.02	L/s

McINTOSH PERRY

MAXIMUM DAILY DEMAND

DEMAND TYPE	AMOUNT		UNITS
Residential	3.6	x avg. day	L/c/d
Industrial	1.5	x avg. day	L/gross ha/d
Commercial	1.5	x avg. day	L/gross ha/d
Institutional	1.5	x avg. day	L/gross ha/d
MAXIMUM DAILY DEMAND	Residential	1.63	L/s
	Commercial/Industrial/ Institutional	0.04	L/s

MAXIMUM HOUR DEMAND

DEMAND TYPE	AMOUNT		UNITS
Residential	5.4	x avg. day	L/c/d
Industrial	1.8	x max. day	L/gross ha/d
Commercial	1.8	x max. day	L/gross ha/d
Institutional	1.8	x max. day	L/gross ha/d
MAXIMUM HOUR DEMAND	Residential	2.45	L/s
	Commercial/Industrial/ Institutional	0.06	L/s

WATER DEMAND DESIGN FLOWS PER UNIT COUNT

CITY OF OTTAWA - WATER DISTRIBUTION GUIDELINES, JULY 2010

AVERAGE DAILY DEMAND	0.48	L/s
MAXIMUM DAILY DEMAND	1.67	L/s
MAXIMUM HOUR DEMAND	2.51	L/s

McINTOSH PERRY

CP-20-0190 - 300 Tremblay - Fire Underwriters Survey

Project: 300 Tremblay
 Project No.: CP-20-0190
 Designed By: RRR
 Checked By: RDF
 Date: July 28, 2023

From the Fire Underwriters Survey (2020)

From Part II – Guide for Determination of Required Fire Flow Copyright I.S.O.:
 City of Ottawa Technical Bulletin ISTB-2018-02 Applied Where Applicable

A. BASE REQUIREMENT (Rounded to the nearest 1000 L/min)

F = 220 x C x vA Where: F = Required fire flow in liters per minute
 C = Coefficient related to the type of construction.
 A = The total effective floor area in square meters (per the 2020 FUS Page 20)

Construction Type Non-Combustible Construction

C	0.8	Gross Floor Area	3,112.6 m ²	
		Total Effective Floor Area (per the 2020 FUS Page 20)	1,844.9 m ²	*Unprotected Vertical Openings

Calculated Fire Flow	7,559.6 L/min
	8,000.0 L/min

B. REDUCTION FOR OCCUPANCY TYPE (No Rounding)

From Page 24 of the Fire Underwriters Survey:
 Limited Combustible -15%

Fire Flow	6,800.0 L/min
-----------	---------------

C. REDUCTION FOR SPRINKLER TYPE (No Rounding)

Fully Supervised Sprinklered -50%

Reduction	-3,400.0 L/min
-----------	----------------

D. INCREASE FOR EXPOSURE (No Rounding)

	Separation Distance (m)	Cons. of Exposed Wall	Length Exposed Adjacent Wall (m)	Height (Stories)	Length-Height Factor	
Exposure 1	Over 30 m	Ordinary - Mass Timber (Unprotected)	20	4	80.0	0%
Exposure 2	Over 30 m	Ordinary - Mass Timber (Unprotected)	20	1	20.0	0%
Exposure 3	Over 30 m	Ordinary - Mass Timber (Unprotected)	20	5	100.0	0%
Exposure 4	Over 30 m	Ordinary - Mass Timber (Unprotected)	20	1	20.0	0%
					% Increase*	0%

Increase*	0.0 L/min
-----------	-----------

E. Total Fire Flow (Rounded to the Nearest 1000 L/min)

Fire Flow	3,400.0 L/min
Fire Flow Required**	3,000.0 L/min

*In accordance with Part II, Section 4, the Increase for separation distance is not to exceed 75%

**In accordance with Section 4 the Fire flow is not to exceed 45,000 L/min or be less than 2,000 L/min

APPENDIX D
SANITARY SEWER CALCULATIONS

McINTOSH PERRY

CCO-20-0190 - 300 Tremblay - Sanitary Demands

Project:	300 Tremblay		
Project No.:	CCO-20-0190		
Designed By:	R.R.R.		
Checked By:	R.R.R.		
Date:	August 18, 2023		

Site Area	0.10	Gross ha		
Bachelor	77		1.40	Persons per unit
1 Bedroom	23		1.40	Persons per unit
Total Population	140	Persons		
Commercial Area	69.40	m ²		
Amenity Space	659.00	m ²		

DESIGN PARAMETERS

Institutional/Commercial Peaking Factor	1.5	*Check technical bulleting (Either use 1.0 or 1.5)
Residential Peaking Factor	3.56	* Using Harmon Formula = $1+(14/(4+P^{0.5}))^{*0.8}$ where P = population in thousands, Harmon's Correction Factor = 0.8
Mannings coefficient (n)	0.013	
Demand (per capita)	280	L/day
Infiltration allowance	0.33	L/s/Ha

EXTRANEOUS FLOW ALLOWANCES

Infiltration / Inflow	Flow (L/s)
Dry	0.01
Wet	0.03
Total	0.03

AVERAGE DAILY DEMAND

DEMAND TYPE	AMOUNT	UNITS	POPULATION / AREA	Flow (L/s)
Residential	280	L/c/d	140	0.45
Industrial - Light**	35,000	L/gross ha/d		0
Industrial - Heavy**	55,000	L/gross ha/d		0
Commercial / Amenity	2,800	L/(1000m ² /d)	728.40	0.02
Hospital	900	L/(bed/day)		0
Schools	70	L/(Student/d)		0
Trailer Parks no Hook-Ups	340	L/(space/d)		0
Trailer Park with Hook-Ups	800	L/(space/d)		0
Campgrounds	225	L/(campsite/d)		0
Mobile Home Parks	1,000	L/(Space/d)		0
Motels	150	L/(bed-space/d)		0
Hotels	225	L/(bed-space/d)		0
Office	75	L/7.0m ² /d		0
Tourist Commercial	28,000	L/gross ha/d		0
Other Commercial	28,000	L/gross ha/d		0

McINTOSH PERRY

AVERAGE RESIDENTIAL FLOW	0.45	L/s
PEAK RESIDENTIAL FLOW	1.62	L/s
AVERAGE ICI FLOW	0.02	L/s
PEAK INSTITUTIONAL/COMMERCIAL FLOW	0.04	L/s
PEAK INDUSTRIAL FLOW	0.00	L/s
TOTAL PEAK ICI FLOW	0.04	L/s

TOTAL SANITARY DEMAND

TOTAL ESTIMATED AVERAGE DRY WEATHER FLOW	0.48	L/s
TOTAL ESTIMATED PEAK DRY WEATHER FLOW	1.66	L/s
TOTAL ESTIMATED PEAK WET WEATHER FLOW	1.69	L/s

** PEAK INDUSTRIAL FLOW PER CITY OF OTTAWA SEWER DESIGN GUIDELINES APPENDIX 4B

SANITARY SEWER DESIGN SHEET

PROJECT: 300 TREMBLAY ROAD
 LOCATION: OTTAWA, ONTARIO
 CLIENT: PROJECT1 STUDIO



LOCATION				RESIDENTIAL								ICI AREAS								INFILTRATION ALLOWANCE			FLOW		SEWER DATA						
1	2	3	4	5	6	7	8	9	10	11	12	13	14	15	16	17	18	19	20	21	22	23	24	25	26	27	28	29	30	31	
LOCATION	AREA ID	FROM MH	TO MH	UNIT TYPES				AREA (ha)	POPULATION		PEAK FACTOR	PEAK FLOW (L/s)	AREA (ha)						PEAK FLOW (L/s)	AREA (ha)		FLOW (L/s)	DESIGN FLOW (L/s)	CAPACITY (L/s)	LENGTH (m)	DIA (mm)	SLOPE (%)	VELOCITY (full) (m/s)	AVAILABLE CAPACITY		
				SF	SD	TH	APT		IND	CUM			INSTITUTIONAL	COMMERCIAL	INDUSTRIAL	IND	CUM	IND		CUM	IND								CUM	IND	CUM
		BLDG	MH1A				100	0.11	140.0	140.0	3.56	1.62		0.00	0.07	0.07		0.00	0.04	0.11	0.11	0.03	1.69	34.22	0.50	200	1.00	1.055	32.53	95.07	
		MH1A	Main						0.0	140.0	3.56	1.62		0.00		0.07		0.00	0.04	0.00	0.11	0.03	1.69	34.22	8.35	200	1.00	1.055	32.53	95.07	
Design Parameters:				Notes:								Designed:								No.			Revision		Date						
Residential				ICI Areas								Peak Factor																			
SF	3.8	p/p/u																													
SD	3.5	p/p/u	INST	50,000	L/Ha/day						1.5																				
TH	2.7	p/p/u	COM	28,000	L/Ha/day						1.5																				
APT	1.4	p/p/u	IND	35,000	L/Ha/day						MOE Chart																				
Other	60	p/p/Ha																													
				1. Mannings coefficient (n) = 0.013								RRR																			
				2. Demand (per capita): 280 L/day								RDF																			
				3. Infiltration allowance: 0.33 L/s/Ha								CP-20-0190																			
				4. Residential Peaking Factor: Harmon Formula = 1+(14/(4+P*0.5)) where P = population in thousands																											
																									Sheet No: 1 of 1						

Charissa Hampel

From: Baker, Adam <adam.baker@ottawa.ca>
Sent: September 25, 2020 9:36 AM
To: Curtis Melanson
Cc: Charissa Hampel
Subject: RE: tremblay

Hi Curtis,

To follow-up, there is no issue with downstream sanitary capacity given the provided calculations.

Thanks,
Adam

Adam Baker, EIT

Project Manager
Planning, Infrastructure and Economic Development Department - Services de la planification, de l'infrastructure et du développement économique
Development Review - South Branch
City of Ottawa | Ville d'Ottawa
110 Laurier Avenue West Ottawa, ON | 110, avenue. Laurier Ouest. Ottawa (Ontario) K1P 1J1
613.580.2424 ext./poste 26552, Adam.Baker@ottawa.ca

From: Baker, Adam
Sent: September 24, 2020 11:39 AM
To: Curtis Melanson <c.melanson@mcintoshperry.com>
Cc: Charissa Hampel <c.hampel@mcintoshperry.com>
Subject: RE: tremblay

Hi Curtis,

I've confirmed some of the points we spoke about, but am still waiting on the confirmation of the sanitary constraints at this property. I'm working on getting those to you as soon as possible. For the time being, please accept the following information:

- Monitoring MH – A standard monitoring MH is required. If you can demonstrate that there will not be enough space for the monitoring MH, using a sampling port can be reviewed. For this, please provide the applicable standard drawings which could be reviewed for this use.
- Storm Sewers – Both the storm sewers on Belfast and Tremblay are available for connection.
- Watermain Looping is required for areas and individual facilities with demand greater than 50m³/day. I've attached the relevant technical bulletin which provides further information regarding Sec. 4.3.1 of the City Water Design Guidelines.

Thanks,
Adam

Adam Baker, EIT

Project Manager
Planning, Infrastructure and Economic Development Department - Services de la planification, de l'infrastructure et du développement économique
Development Review - South Branch

City of Ottawa | Ville d'Ottawa
110 Laurier Avenue West Ottawa, ON | 110, avenue. Laurier Ouest. Ottawa (Ontario) K1P 1J1
613.580.2424 ext./poste 26552, Adam.Baker@ottawa.ca

From: Curtis Melanson <c.melanson@mcintoshperry.com>
Sent: September 24, 2020 9:21 AM
To: Baker, Adam <adam.baker@ottawa.ca>
Cc: Charissa Hampel <c.hampel@mcintoshperry.com>
Subject: RE: tremblay

CAUTION: This email originated from an External Sender. Please do not click links or open attachments unless you recognize the source.

ATTENTION : Ce courriel provient d'un expéditeur externe. Ne cliquez sur aucun lien et n'ouvrez pas de pièce jointe, excepté si vous connaissez l'expéditeur.

Hi Adam,
Just following up on this one. Can you get back to me whenever you get a moment?

Thanks,

Curtis Melanson, C.E.T.

Practice Area Lead, Land Development

T. 613.714.4621 | **F.** 613.836.3742 | **C.** 613.857.0784

McINTOSH PERRY

From: Curtis Melanson <c.melanson@mcintoshperry.com>
Sent: September 23, 2020 11:50 AM
To: Baker, Adam <adam.baker@ottawa.ca>
Cc: Charissa Hampel <c.hampel@mcintoshperry.com>
Subject: RE: tremblay

Hi Adam,
Just following up on this one to see if we can get some answers from our previous phone conversation?

Thanks,

Curtis Melanson, C.E.T.

Practice Area Lead, Land Development

T. 613.714.4621 | **F.** 613.836.3742 | **C.** 613.857.0784

McINTOSH PERRY

From: Curtis Melanson <c.melanson@mcintoshperry.com>
Sent: September 14, 2020 3:20 PM
To: Baker, Adam <adam.baker@ottawa.ca>
Subject: tremblay

Curtis Melanson, C.E.T.

Practice Area Lead, Land Development

115 Walgreen Road, R.R. 3, Carp, ON K0A 1L0
T. 613.714.4621 | F. 613.836.3742 | C. 613.857.0784
c.melanson@mcintoshperry.com | www.mcintoshperry.com

McINTOSH PERRY

Confidentiality Notice – If this email wasn't intended for you, please return or delete it. Click [here](#) to read all of the legal language around this concept.

We have been informed that a number of our clients have received phishing emails from scammers pretending to be McIntosh Perry.

We take information security very seriously and ask that you also be vigilant in order to prevent fraud.

If you have any concerns, please let your contact at McIntosh Perry know or email us at info@mcintoshperry.com



Platinum member

This e-mail originates from the City of Ottawa e-mail system. Any distribution, use or copying of this e-mail or the information it contains by other than the intended recipient(s) is unauthorized. Thank you.

Le présent courriel a été expédié par le système de courriels de la Ville d'Ottawa. Toute distribution, utilisation ou reproduction du courriel ou des renseignements qui s'y trouvent par une personne autre que son destinataire prévu est interdite. Je vous remercie de votre collaboration.

APPENDIX E
PRE-DEVELOPMENT DRAINAGE PLAN

FILENAME: U:\Drawings\019 Project - Proposed\2020\019\CP-20-019\15 - Apartment Building_300 Tremblay Road\12 - Drawing\CP-20-0190_Presentation.dwg
 LAST SAVED: Thursday, October 12, 2023 1:51:54 PM BY: jrobshaw
 LAST PLOTTED: Thursday, October 12, 2023 1:51:54 PM

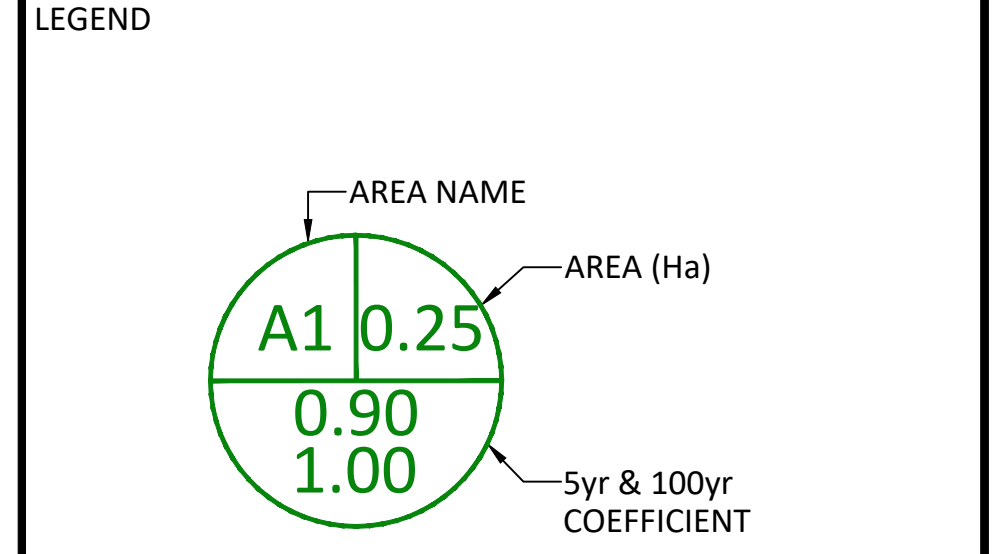
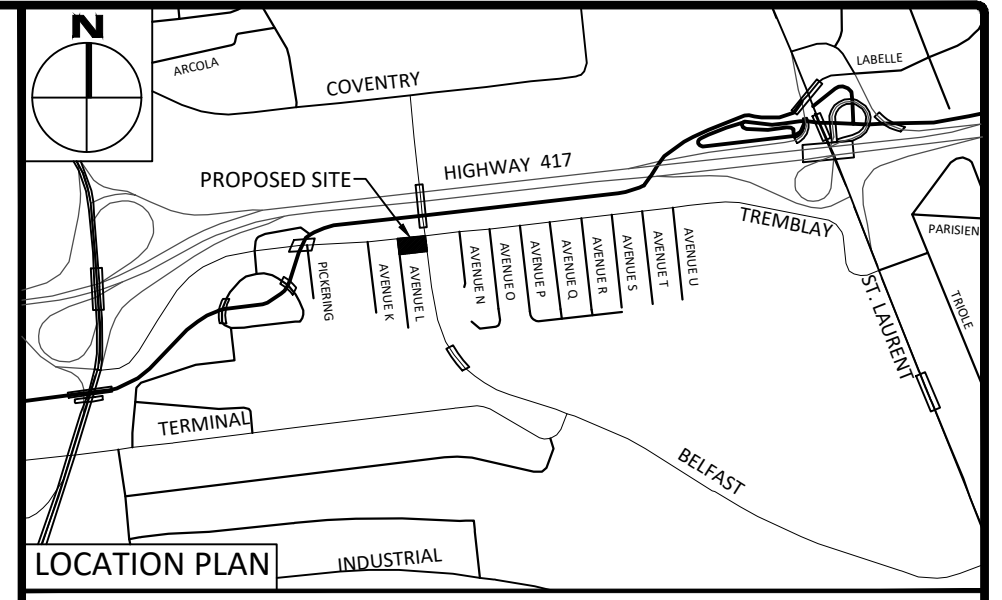
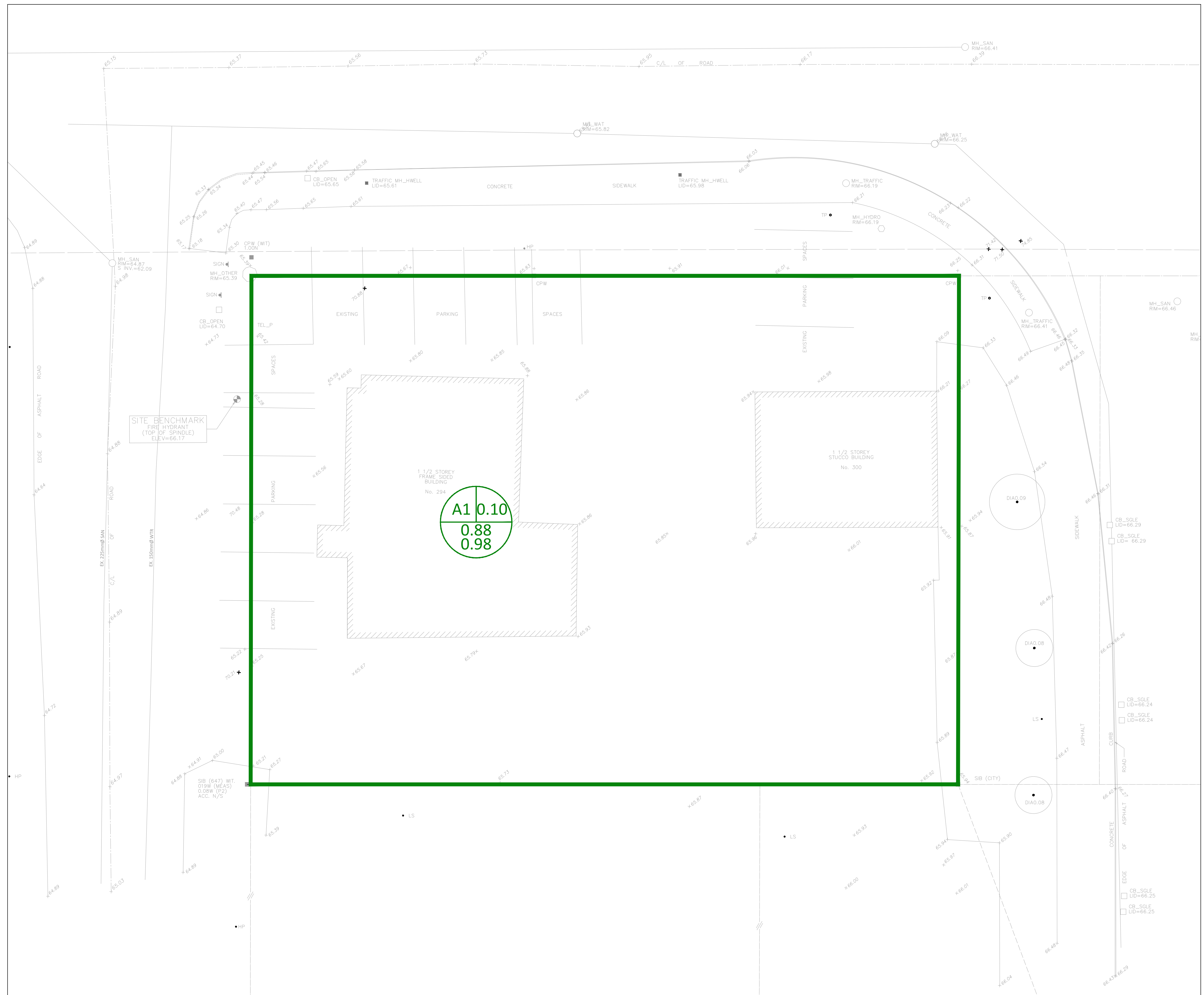

No.	Revisions	Date
2	ISSUED FOR SITE PLAN REVISION	OCT 05, 2023
1	ISSUED FOR APPROVAL	SEP. 30, 2020

Check and verify all dimensions before proceeding with the work. Do not scale drawings.
 SCALE 1 : 100
 0 2 4 6 8 10 Metres

McINTOSH PERRY
 115 Walgreen Road, RR3, Carp, ON K0A 1L0
 Tel: 613-836-2184 Fax: 613-836-3742
 www.mcintoshperry.com

Client: **PROJECT 1 STUDIOS**
 300-260 ST. PATRICK STREET
 OTTAWA, ON K1N 5K5

Project: **300 TREMBLAY**
 300 TREMBLAY ROAD

Drawing Title: **PRE-DEVELOPMENT DRAINAGE AREA PLAN**

Scale: 1:100	Project Number: CP-20-0190
Drawn By: C.D.H.	
Checked By: R.P.K.	Drawing Number: PRE
Designed By: C.D.H.	

D07-12-XX-XXXX

#XXXXX

APPENDIX F
POST-DEVELOPMENT DRAINAGE PLAN

FILENAME: \\C:\Users\p1\OneDrive - Personal\Documents\2023\Projects\300 Tremblay Road\12 - Drawing\CP-20-0190 - Post-development.dwg
 DATE SAVED: Thursday, October 12, 2023 1:51:54 PM
 LAST PLOTTED: Thursday, October 12, 2023 1:51:54 PM

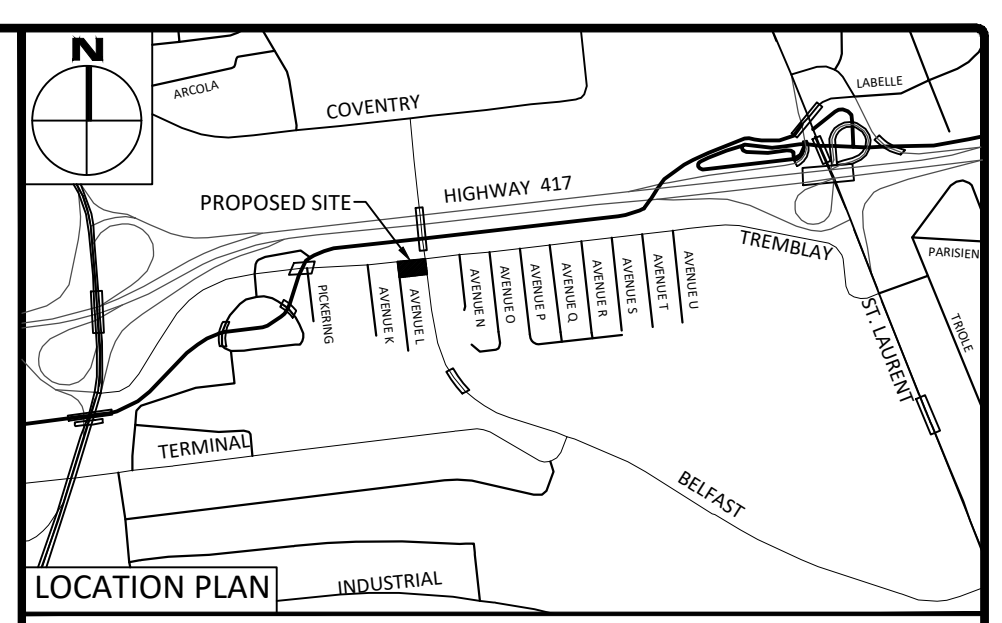
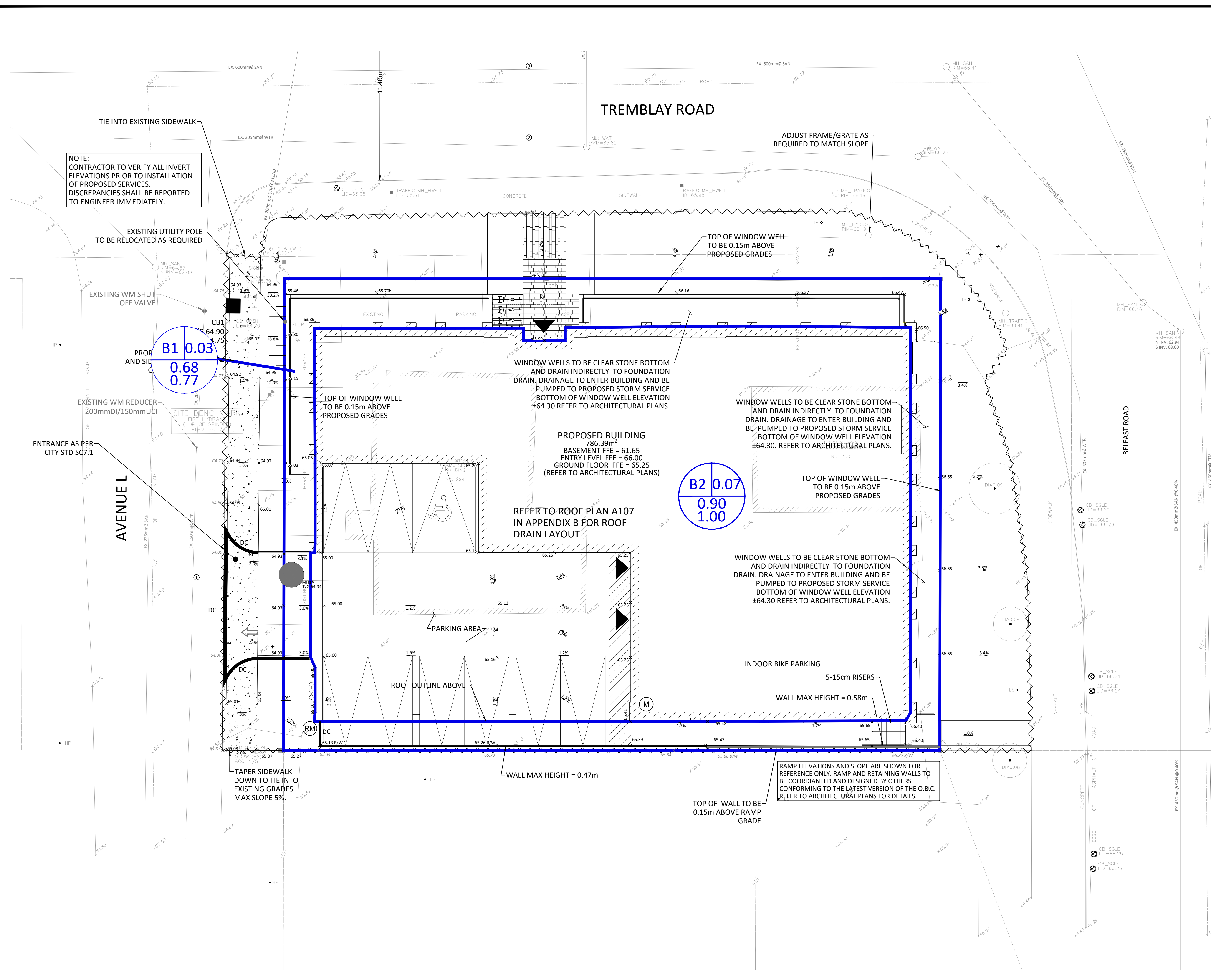

LEGEND

AREA NAME	AREA (Ha)	5yr & 100yr COEFFICIENT
B1	0.25	0.90 / 1.00
B2	0.07	0.90 / 1.00
B3	0.03	0.68 / 0.77

No.	Revisions	Date
2	ISSUED FOR SITE PLAN REVISION	OCT 05, 2023
1	ISSUED FOR APPROVAL	SEP. 30, 2020

Check and verify all dimensions before proceeding with the work. Do not scale drawings.

SCALE 1:100

McINTOSH PERRY
 115 Walgreen Road, RR3, Carp, ON K0A 1L0
 Tel: 613-836-2184 Fax: 613-836-3742
 www.mcintoshperry.com

	Stamp:

Client: PROJECT 1 STUDIOS
 300-260 ST. PATRICK STREET
 OTTAWA, ON K1N 5K5

Project: 300 TREMBLAY
 300 TREMBLAY ROAD

Drawing Title: POST-DEVELOPMENT DRAINAGE AREA PLAN

Scale: 1:100	Project Number: CP-20-0190
Drawn By: R.R.R.	Checked By: B.S.C.
Designed By: R.R.R.	Drawing Number: POST

D07-12-XX-XXXX

#XXXX

APPENDIX G
STORMWATER MANAGEMENT CALCULATIONS

McINTOSH PERRY

CP-20-0190 - 300 TREMBLAY ROAD - Stormwater Management

1 of 3

C-Values		
	5-Year	100-Year
Impervious	0.90	1.00
Gravel	0.60	0.75
Pervious	0.20	0.25

$$C_{100\text{YEAR}} = C_{5\text{YEAR}} * 1.25$$

Note, $C_{100\text{Year}}$ is not to exceed 1.0

Pre-Development Runoff Coefficient

Drainage Area	Area (ha)	Impervious Area (m ²)	Gravel Area (m ²)	C Gravel	Pervious Area (m ²)	C Pervious	C _{AVG} 2&5-Year	C _{AVG} 100-Year
A1	0.10	1,018.78	0.00	0.60	27.81	0.20	0.88	0.98

Pre-Development Runoff Calculations

Drainage Area	Area (ha)	C 2&5-Year	C 100-Year	Tc (min)	I (mm/hr)			Q (L/s)	
					2-Year	5-Year	100-Year	5-Year	100-Year
					A1	0.10	0.88	0.98	10
Total	0.10							26.72	50.92

Post-Development Runoff Coefficient

Drainage Area	Area (ha)	Impervious Area (m ²)	Gravel Area (m ²)	Pervious Area (m ²)	C _{AVG} 2&5-Year	C _{AVG} 100-Year
B1	0.03	175.11	0.00	78.21	0.68	0.77
B2	0.08	793.28	0.00	0	0.90	1.00

Post-Development Runoff Calculations

Drainage Area	Area (ha)	C 5-Year	C 100-Year	Tc (min)	I (mm/hr)		Q (L/s)	
					5-Year	100-Year	5-Year	100-Year
					B1	0.03	0.68	0.77
B2	0.08	0.90	1.00	10	104.2	178.6	20.68	39.38
Total	0.10						25.70	49.04

Required Restricted Flow

Drainage Area	Area (ha)	C 5-Year	Tc (min)	I (mm/hr) 5-Year	Q (L/s) 5-Year
A1	0.10	0.50	10	104.2	15.16

100-year restricted flow to match 5-year pre-development flow at a C = 0.50

Post-Development Restricted Runoff Calculations

Drainage Area	Unrestricted Flow (L/s)		Restricted Flow (L/s)	
	5-Year	100-Year	5-Year	100-Year
B1	5.02	9.66	5.02	9.66
B2	20.68	39.38	2.88	4.80
Total	25.70	49.04	7.90	14.46

Roof Drain Flow (B2)

Roof Drains Summary		
Type of Control Device	Watts Drainage - Accutrol Weir	
Number of Roof Drains	8	
	5-Year	100 Year
Rooftop Storage Provided (m ³)	17.85	29.75
Storage Depth (mm)	0.030	0.050
Flow (Per Roof Drain) (L/s)	0.36	0.60
Total Flow (L/s)	2.88	4.80

Flow Rate Vs. Depth (One Weir Fully Exposed)	
Depth (mm)	Flow (L/s)
15	0.18
20	0.24
25	0.30
30	0.36
35	0.42
40	0.48
45	0.54
50	0.60
55	0.66

*Roof Drain model to be Accutrol Weirs, See attached sheets
 *Roof Drain Flow information taken from Watts Drainage website

CALCULATING ROOF FLOW EXAMPLES

1 roof drain during a 5 year storm
 elevation of water = 25mm
 Flow leaving 1 roof drain = (1 x 0.30 L/s) = 0.30 L/s

1 roof drain during a 100 year storm
 elevation of water = 50mm
 Flow leaving 1 roof drain = (1 x 0.60 L/s) = 0.60 L/s

4 roof drains during a 5 year storm
 elevation of water = 25mm
 Flow leaving 4 roof drains = (4 x 0.30 L/s) = 1.20 L/s

4 roof drains during a 100 year storm
 elevation of water = 50mm
 Flow leaving 4 roof drains = (4 x 0.60 L/s) = 2.40 L/s

Roof Drain Flow		
Flow (L/s)	Storage Depth (mm)	Roof Drains Flow (L/s)
0.18	15	1.44
0.24	20	1.92
0.30	25	2.40
0.36	30	2.88
0.42	35	3.36
0.48	40	3.84
0.54	45	4.32
0.60	50	4.80
0.66	55	5.28
0.72	60	5.76
0.78	65	6.24
0.84	70	6.72
0.90	75	7.20
0.96	80	7.68
1.02	85	8.16
1.08	90	8.64
1.14	95	9.12
1.20	100	9.60
1.26	105	10.08
1.32	110	10.56
1.38	115	11.04
1.44	120	11.52
1.50	125	12.00
1.56	130	12.48
1.62	135	12.96
1.68	140	13.44
1.74	145	13.92
1.80	150	14.40

McINTOSH PERRY

300 TREMBLAY ROAD STORAGE REQUIREMENTS

Storage Requirements for Area B2

5-Year Storm Event

Tc (min)	I (mm/hr)	B2 Runoff (L/s)	Allowable Outflow (L/s)	Runoff to be Stored (L/s)	Storage Required (m ³)
10	104.2	20.68	2.88	17.80	10.68
15	83.6	16.58	2.88	13.70	12.33
20	70.3	13.94	2.88	11.06	13.28
25	60.9	12.09	2.88	9.21	13.81
30	53.9	10.70	2.88	7.82	14.08
35	48.5	9.63	2.88	6.75	14.17
40	44.2	8.77	2.88	5.89	14.14
45	40.6	8.06	2.88	5.18	14.00
50	37.7	7.47	2.88	4.59	13.78
55	35.1	6.97	2.88	4.09	13.50
60	32.9	6.54	2.88	3.66	13.17

Maximum Storage Required 5-Year (m ³) =	14.17
---	-------

100-Year Storm Event

Tc (min)	I (mm/hr)	B2 Runoff (L/s)	Allowable Outflow (L/s)	Runoff to be Stored (L/s)	Storage Required (m ³)
10	178.6	39.38	4.80	34.58	20.75
15	142.9	31.51	4.80	26.71	24.04
20	120.0	26.45	4.80	21.65	25.98
25	103.8	22.90	4.80	18.10	27.15
30	91.9	20.26	4.80	15.46	27.83
35	82.6	18.21	4.80	13.41	28.16
40	75.1	16.57	4.80	11.77	28.25
45	69.1	15.23	4.80	10.43	28.15
50	64.0	14.10	4.80	9.30	27.91
55	59.6	13.15	4.80	8.35	27.55
60	55.9	12.33	4.80	7.53	27.10

Maximum Storage Required 100-Year (m ³) =	28.25
---	-------

STORAGE OCCUPIED IN AREA B2

5-Year Storm Event

Location	T/G	INV. (out)	75% of Area (m ²)	Depth (m)	Volume (m ³)
ROOF	N/A	N/A	595.0	0.030	17.8
				Total	17.8

Storage Available (m ³) =	17.8
Storage Required (m ³) =	14.2

100-YEAR STORM EVENT

Location	T/G	INV. (out)	75% of Area (m ²)	Depth (m)	Volume (m ³)
ROOF	N/A	N/A	595.0	0.050	29.7
				Total	29.7

Storage Available (m ³) =	29.7
Storage Required (m ³) =	28.3



Adjustable Accutrol Weir

Tag: _____

Adjustable Flow Control for Roof Drains

ADJUSTABLE ACCUTROL (for Large Sump Roof Drains only)

For more flexibility in controlling flow with heads deeper than 2", Watts Drainage offers the Adjustable Accutrol. The Adjustable Accutrol Weir is designed with a single parabolic opening that can be covered to restrict flow above 2" of head to less than 5 gpm per inch, up to 6" of head. To adjust the flow rate for depths over 2" of head, set the slot in the adjustable upper cone according to the flow rate required. Refer to Table 1 below.
 Note: Flow rates are directly proportional to the amount of weir opening that is exposed.

EXAMPLE:

For example, if the adjustable upper cone is set to cover 1/2 of the weir opening, flow rates above 2" of head will be restricted to 2-1/2 gpm per inch of head.

Therefore, at 3" of head, the flow rate through the Accutrol Weir that has 1/2 the slot exposed will be:
 [5 gpm (per inch of head) x 2 inches of head] + 2-1/2 gpm (for the third inch of head) = 12-1/2 gpm.

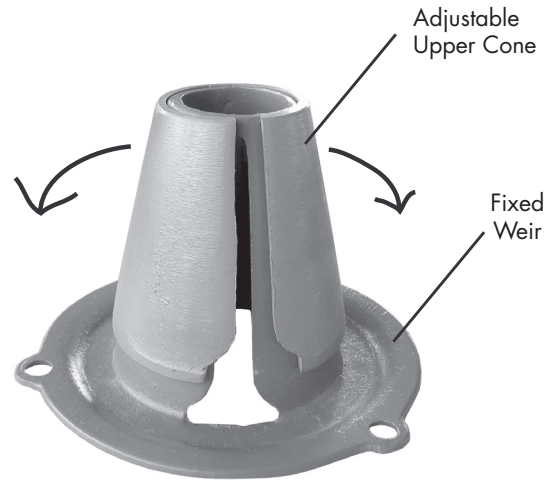
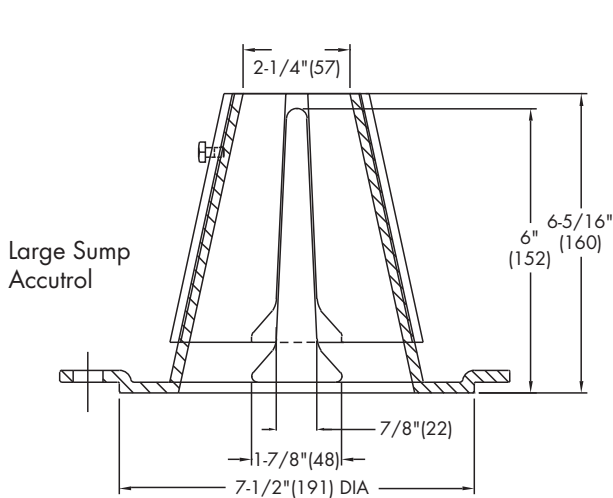

1/2 Weir Opening Exposed Shown Above

TABLE 1. Adjustable Accutrol Flow Rate Settings

Weir Opening Exposed	1"	2"	3"	4"	5"	6"
	Flow Rate (gallons per minute)					
Fully Exposed	5	10	15	20	25	30
3/4	5	10	13.75	17.5	21.25	25
1/2	5	10	12.5	15	17.5	20
1/4	5	10	11.25	12.5	13.75	15
Closed	5	5	5	5	5	5

Job Name _____
 Job Location _____
 Engineer _____

Contractor _____
 Contractor's P.O. No. _____
 Representative _____

Watts product specifications in U.S. customary units and metric are approximate and are provided for reference only. For precise measurements, please contact Watts Technical Service. Watts reserves the right to change or modify product design, construction, specifications, or materials without prior notice and without incurring any obligation to make such changes and modifications on Watts products previously or subsequently sold.

USA: Tel: (800) 338-2581 • Fax: (828) 248-3929 • Watts.com
 Canada: Tel: (905) 332-4090 • Fax: (905) 332-7068 • Watts.ca
 Latin America: Tel: (52) 81-1001-8600 • Fax: (52) 81-8000-7091 • Watts.com



APPENDIX I
CITY OF OTTAWA DESIGN CHECKLIST

City of Ottawa

4. Development Servicing Study Checklist

The following section describes the checklist of the required content of servicing studies. It is expected that the proponent will address each one of the following items for the study to be deemed complete and ready for review by City of Ottawa Infrastructure Approvals staff.

The level of required detail in the Servicing Study will increase depending on the type of application. For example, for Official Plan amendments and re-zoning applications, the main issues will be to determine the capacity requirements for the proposed change in land use and confirm this against the existing capacity constraint, and to define the solutions, phasing of works and the financing of works to address the capacity constraint. For subdivisions and site plans, the above will be required with additional detailed information supporting the servicing within the development boundary.

4.1 General Content

Criteria	Location (if applicable)
<ul style="list-style-type: none"> Executive Summary (for larger reports only). 	N/A
<ul style="list-style-type: none"> Date and revision number of the report. 	On Cover
<ul style="list-style-type: none"> Location map and plan showing municipal address, boundary, and layout of proposed development. 	Appendix A
<ul style="list-style-type: none"> Plan showing the site and location of all existing services. 	Plan (C101)
<ul style="list-style-type: none"> Development statistics, land use, density, adherence to zoning and official plan, and reference to applicable subwatershed and watershed plans that provide context to which individual developments must adhere. 	1.1 Purpose 1.2 Site Description 6.0 Stormwater Management
<ul style="list-style-type: none"> Summary of pre-consultation meetings with City and other approval agencies. 	Appendix B
<ul style="list-style-type: none"> Reference and confirm conformance to higher level studies and reports (Master Servicing Studies, Environmental Assessments, Community Design Plans), or in the case where it is not in conformance, the proponent must provide justification and develop a defensible design criteria. 	1.1 Purpose 1.2 Site Description 6.0 Stormwater Management
<ul style="list-style-type: none"> Statement of objectives and servicing criteria. 	3.0 Pre-Consultation Summary

<ul style="list-style-type: none"> ● Identification of existing and proposed infrastructure available in the immediate area. 	N/A
<ul style="list-style-type: none"> ● Identification of Environmentally Significant Areas, watercourses and Municipal Drains potentially impacted by the proposed development (Reference can be made to the Natural Heritage Studies, if available). 	Site Grading, Drainage, Sediment & Erosion Control Plan (C101)
<ul style="list-style-type: none"> ● Concept level master grading plan to confirm existing and proposed grades in the development. This is required to confirm the feasibility of proposed stormwater management and drainage, soil removal and fill constraints, and potential impacts to neighbouring properties. This is also required to confirm that the proposed grading will not impede existing major system flow paths. 	Site Grading, Drainage, Sediment & Erosion Control Plan (C101)
<ul style="list-style-type: none"> ● Identification of potential impacts of proposed piped services on private services (such as wells and septic fields on adjacent lands) and mitigation required to address potential impacts. 	N/A
<ul style="list-style-type: none"> ● Proposed phasing of the development, if applicable. 	N/A
<ul style="list-style-type: none"> ● Reference to geotechnical studies and recommendations concerning servicing. 	Section 2.0 Background Studies
<ul style="list-style-type: none"> ● All preliminary and formal site plan submissions should have the following information: <ul style="list-style-type: none"> ○ Metric scale ○ North arrow (including construction North) ○ Key plan ○ Name and contact information of applicant and property owner ○ Property limits including bearings and dimensions ○ Existing and proposed structures and parking areas ○ Easements, road widening and rights-of-way ○ Adjacent street names 	Site Grading, Drainage, Sediment & Erosion Control Plan (C101)

4.2 Development Servicing Report: Water

Criteria	Location (if applicable)
<ul style="list-style-type: none"> Confirm consistency with Master Servicing Study, if available 	N/A
<ul style="list-style-type: none"> Availability of public infrastructure to service proposed development 	N/A
<ul style="list-style-type: none"> Identification of system constraints 	N/A
<ul style="list-style-type: none"> Identify boundary conditions 	N/A
<ul style="list-style-type: none"> Confirmation of adequate domestic supply and pressure 	N/A
<ul style="list-style-type: none"> Confirmation of adequate fire flow protection and confirmation that fire flow is calculated as per the Fire Underwriter's Survey. Output should show available fire flow at locations throughout the development. 	Appendix C
<ul style="list-style-type: none"> Provide a check of high pressures. If pressure is found to be high, an assessment is required to confirm the application of pressure reducing valves. 	N/A
<ul style="list-style-type: none"> Definition of phasing constraints. Hydraulic modeling is required to confirm servicing for all defined phases of the project including the ultimate design 	N/A
<ul style="list-style-type: none"> Address reliability requirements such as appropriate location of shut-off valves 	N/A
<ul style="list-style-type: none"> Check on the necessity of a pressure zone boundary modification. 	N/A
<ul style="list-style-type: none"> Reference to water supply analysis to show that major infrastructure is capable of delivering sufficient water for the proposed land use. This includes data that shows that the expected demands under average day, peak hour and fire flow conditions provide water within the required pressure range 	N/A

<ul style="list-style-type: none"> Description of the proposed water distribution network, including locations of proposed connections to the existing system, provisions for necessary looping, and appurtenances (valves, pressure reducing valves, valve chambers, and fire hydrants) including special metering provisions. 	N/A
<ul style="list-style-type: none"> Description of off-site required feeder mains, booster pumping stations, and other water infrastructure that will be ultimately required to service proposed development, including financing, interim facilities, and timing of implementation. 	N/A
<ul style="list-style-type: none"> Confirmation that water demands are calculated based on the City of Ottawa Design Guidelines. 	Appendix C
<ul style="list-style-type: none"> Provision of a model schematic showing the boundary conditions locations, streets, parcels, and building locations for reference. 	N/A

4.3 Development Servicing Report: Wastewater

Criteria	Location (if applicable)
<ul style="list-style-type: none"> Summary of proposed design criteria (Note: Wet-weather flow criteria should not deviate from the City of Ottawa Sewer Design Guidelines. Monitored flow data from relatively new infrastructure cannot be used to justify capacity requirements for proposed infrastructure). 	N/A
<ul style="list-style-type: none"> Confirm consistency with Master Servicing Study and/or justifications for deviations. 	N/A
<ul style="list-style-type: none"> Consideration of local conditions that may contribute to extraneous flows that are higher than the recommended flows in the guidelines. This includes groundwater and soil conditions, and age and condition of sewers. 	N/A
<ul style="list-style-type: none"> Description of existing sanitary sewer available for discharge of wastewater from proposed development. 	Section 5.2 Sanitary Sewer

<ul style="list-style-type: none"> • Verify available capacity in downstream sanitary sewer and/or identification of upgrades necessary to service the proposed development. (Reference can be made to previously completed Master Servicing Study if applicable) 	N/A
<ul style="list-style-type: none"> • Calculations related to dry-weather and wet-weather flow rates from the development in standard MOE sanitary sewer design table (Appendix 'C') format. 	N/A
<ul style="list-style-type: none"> • Description of proposed sewer network including sewers, pumping stations, and forcemains. 	Section 5.2 Sanitary Sewer
<ul style="list-style-type: none"> • Discussion of previously identified environmental constraints and impact on servicing (environmental constraints are related to limitations imposed on the development in order to preserve the physical condition of watercourses, vegetation, soil cover, as well as protecting against water quantity and quality). 	N/A
<ul style="list-style-type: none"> • Pumping stations: impacts of proposed development on existing pumping stations or requirements for new pumping station to service development. 	N/A
<ul style="list-style-type: none"> • Forcemain capacity in terms of operational redundancy, surge pressure and maximum flow velocity. 	N/A
<ul style="list-style-type: none"> • Identification and implementation of the emergency overflow from sanitary pumping stations in relation to the hydraulic grade line to protect against basement flooding. 	N/A
<ul style="list-style-type: none"> • Special considerations such as contamination, corrosive environment etc. 	N/A

4.4 Development Servicing Report: Stormwater Checklist

Criteria	Location (if applicable)
<ul style="list-style-type: none"> Description of drainage outlets and downstream constraints including legality of outlets (i.e. municipal drain, right-of-way, watercourse, or private property) 	Section 6.0 Stormwater Management
<ul style="list-style-type: none"> Analysis of available capacity in existing public infrastructure. 	N/A
<ul style="list-style-type: none"> A drawing showing the subject lands, its surroundings, the receiving watercourse, existing drainage patterns, and proposed drainage pattern. 	Pre & Post-Development Plans
<ul style="list-style-type: none"> Water quantity control objective (e.g. controlling post-development peak flows to pre-development level for storm events ranging from the 2 or 5-year event (dependent on the receiving sewer design) to 100-year return period); if other objectives are being applied, a rationale must be included with reference to hydrologic analyses of the potentially affected subwatersheds, taking into account long-term cumulative effects. 	Section 6.0 Stormwater Management
<ul style="list-style-type: none"> Water Quality control objective (basic, normal or enhanced level of protection based on the sensitivities of the receiving watercourse) and storage requirements. 	Section 6.0 Stormwater Management
<ul style="list-style-type: none"> Description of the stormwater management concept with facility locations and descriptions with references and supporting information. 	Section 6.0 Stormwater Management
<ul style="list-style-type: none"> Set-back from private sewage disposal systems. 	N/A
<ul style="list-style-type: none"> Watercourse and hazard lands setbacks. 	N/A
<ul style="list-style-type: none"> Record of pre-consultation with the Ontario Ministry of Environment and the Conservation Authority that has jurisdiction on the affected watershed. 	N/A
<ul style="list-style-type: none"> Confirm consistency with sub-watershed and Master Servicing Study, if applicable study exists. 	N/A
<ul style="list-style-type: none"> Storage requirements (complete with calculations) and conveyance capacity for minor events (1:5-year return period) and major events (1:100-year return period). 	Appendix F

<ul style="list-style-type: none"> • Identification of watercourses within the proposed development and how watercourses will be protected, or, if necessary, altered by the proposed development with applicable approvals. 	Site Grading, Drainage, Sediment & Erosion Control Plan
<ul style="list-style-type: none"> • Calculate pre-and post development peak flow rates including a description of existing site conditions and proposed impervious areas and drainage catchments in comparison to existing conditions. 	Section 6.0 Stormwater Management Appendix F
<ul style="list-style-type: none"> • Any proposed diversion of drainage catchment areas from one outlet to another. 	Section 6.0 Stormwater Management
<ul style="list-style-type: none"> • Proposed minor and major systems including locations and sizes of stormwater trunk sewers, and stormwater management facilities. 	Section 6.0 Stormwater Management
<ul style="list-style-type: none"> • If quantity control is not proposed, demonstration that downstream system has adequate capacity for the post-development flows up to and including the 100-year return period storm event. 	Appendix A
<ul style="list-style-type: none"> • Identification of potential impacts to receiving watercourses 	N/A
<ul style="list-style-type: none"> • Identification of municipal drains and related approval requirements. 	N/A
<ul style="list-style-type: none"> • Descriptions of how the conveyance and storage capacity will be achieved for the development. 	Section 6.0 Stormwater Management
<ul style="list-style-type: none"> • 100-year flood levels and major flow routing to protect proposed development from flooding for establishing minimum building elevations (MBE) and overall grading. 	Site Grading, Drainage, Sediment & Erosion Control Plan (C101)
<ul style="list-style-type: none"> • Inclusion of hydraulic analysis including hydraulic grade line elevations. 	N/A

<ul style="list-style-type: none"> • Description of approach to erosion and sediment control during construction for the protection of receiving watercourse or drainage corridors. 	Section 7.0 Sediment & Erosion Control
<ul style="list-style-type: none"> • Identification of floodplains – proponent to obtain relevant floodplain information from the appropriate Conservation Authority. The proponent may be required to delineate floodplain elevations to the satisfaction of the Conservation Authority if such information is not available or if information does not match current conditions. 	N/A
<ul style="list-style-type: none"> • Identification of fill constraints related to floodplain and geotechnical investigation. 	N/A

4.5 Approval and Permit Requirements: Checklist

The Servicing Study shall provide a list of applicable permits and regulatory approvals necessary for the proposed development as well as the relevant issues affecting each approval. The approval and permitting shall include but not be limited to the following:

Criteria	Location (if applicable)
<ul style="list-style-type: none"> • Conservation Authority as the designated approval agency for modification of floodplain, potential impact on fish habitat, proposed works in or adjacent to a watercourse, cut/fill permits and Approval under Lakes and Rivers Improvement Act. The Conservation Authority is not the approval authority for the Lakes and Rivers Improvement Act. Where there are Conservation Authority regulations in place, approval under the Lakes and Rivers Improvement Act is not required, except in cases of dams as defined in the Act. 	N/A
<ul style="list-style-type: none"> • Application for Certificate of Approval (CofA) under the Ontario Water Resources Act. 	N/A
<ul style="list-style-type: none"> • Changes to Municipal Drains. 	N/A
<ul style="list-style-type: none"> • Other permits (National Capital Commission, Parks Canada, Public Works and Government Services Canada, Ministry of Transportation etc.) 	N/A

4.6 Conclusion Checklist

Criteria	Location (if applicable)
<ul style="list-style-type: none">Clearly stated conclusions and recommendations	Section 8.0 Summary Section 9.0 Recommendations
<ul style="list-style-type: none">Comments received from review agencies including the City of Ottawa and information on how the comments were addressed. Final sign-off from the responsible reviewing agency.	All are stamped
<ul style="list-style-type: none">All draft and final reports shall be signed and stamped by a professional Engineer registered in Ontario	All are stamped