

## Engineering

Land/Site  
Development  
Municipal  
Infrastructure  
Environmental/  
Water Resources  
Traffic/  
Transportation  
Recreational

## Planning

Land/Site  
Development  
Planning Application  
Management  
Municipal Planning  
Urban Design  
Expert Witness  
(LPAT)  
Wireless Industry

## Landscape Architecture

Streetscapes &  
Public Amenities  
Open Space, Parks &  
Recreation  
Community &  
Residential  
Commercial &  
Institutional  
Environmental  
Restoration

## Rhythm Apartments

### 3080 Navan Road

### Servicing and Stormwater Management Report



**Rhythm Apartments**  
**3080 Navan Road**  
**City of Ottawa**  
**Servicing and Stormwater Management Report**

Prepared By:

**NOVATECH**  
Suite 200, 240 Michael Cowpland Drive  
Ottawa, Ontario  
K2M 1P6

Issued: April / 26 / 2023  
Revised: September / 07 / 2023

Novatech File: 122180  
Ref: R-2023-077

September 07, 2023

City of Ottawa  
Planning, Infrastructure and Economic Development Department  
Planning and Infrastructure Approvals Branch  
110 Laurier Avenue West, 4<sup>th</sup> Floor  
Ottawa ON, K1P 1J1

**Attention: Lucy Ramirez, Planner, Development Review**

**Reference: Rhythm Apartments  
Servicing and Stormwater Management Report  
Our File No.: 122180**

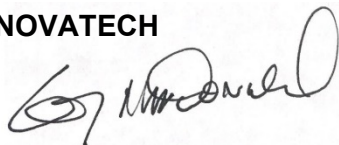
---

Please find enclosed the 'Servicing and Stormwater Management Report' for the above noted development located in the City of Ottawa. This report is being submitted in support of the site plan application for the proposed development.

Should you have any questions or require additional information, please contact the undersigned.

Yours truly,

**NOVATECH**



Greg MacDonald, P. Eng.  
Director, Land Development and Public Sector Infrastructure

**Table of Contents**

**1.0 INTRODUCTION..... 1**

    1.1 Existing Conditions ..... 1

    1.2 Proposed Development ..... 1

**2.0 SITE CONSTRAINTS..... 2**

**3.0 WATER SERVICING..... 3**

**4.0 SANITARY SERVICING ..... 4**

**5.0 STORM SERVICING..... 5**

**6.0 STORM DRAINAGE AND STORMWATER MANAGEMENT ..... 5**

    6.1 Design Criteria ..... 5

    6.2 Quantity Control..... 6

    6.3 Major Overland Flow Route ..... 9

    6.4 Cistern Operation and Maintenance..... 9

**7.0 EROSION AND SEDIMENT CONTROL ..... 9**

**8.0 CONCLUSIONS AND RECOMMENDATIONS .....10**

**9.0 CLOSURE.....11**

**Appendices**

    Appendix A Pre - Consultation Meeting Minutes ..... 12

    Appendix B Water Servicing ..... 13

    Appendix C Sanitary Servicing..... 14

    Appendix D Storm Servicing ..... 15

**Tables**

Table 3.1: Domestic Water Demand Summary ..... 3

Table 3.2: Water Boundary Conditions and Hydraulic Analysis Summary ..... 3

Table 5.1: Storm Sewer Design Parameters ..... 5

Table 6.1: Stormwater Management Summary ..... 8

Table 6.2: Cistern Routine Inspection List..... 9

**Figures**

Figure 1      Key Plan

Figure 2      Existing Conditions

Figure 3      Proposed Site Plan

Figure 4      Existing Drainage Ditch



## 1.0 INTRODUCTION

Novatech has been retained to prepare a Servicing and Stormwater Management Report for the proposed site plan located at 3080 Navan Road within the City of Ottawa. The proposed site is denoted as Block 64 of the Caivan Rhythm residential development and is presently named Rhythm Apartments. The purpose of this report is to support the site plan application for the subject development. **Figure 1** Key Plan shows the site location.

### 1.1 Existing Conditions

The subject site is approximately 0.67 hectares (ha.) in size and is denoted as Block 64 of the Caivan Rhythm residential development. Presently the site consists of a temporary gravel construction staging area for the neighboring subdivision. Historically the site contained two (2) one (1) storey buildings, with individual accesses from Navan Road.

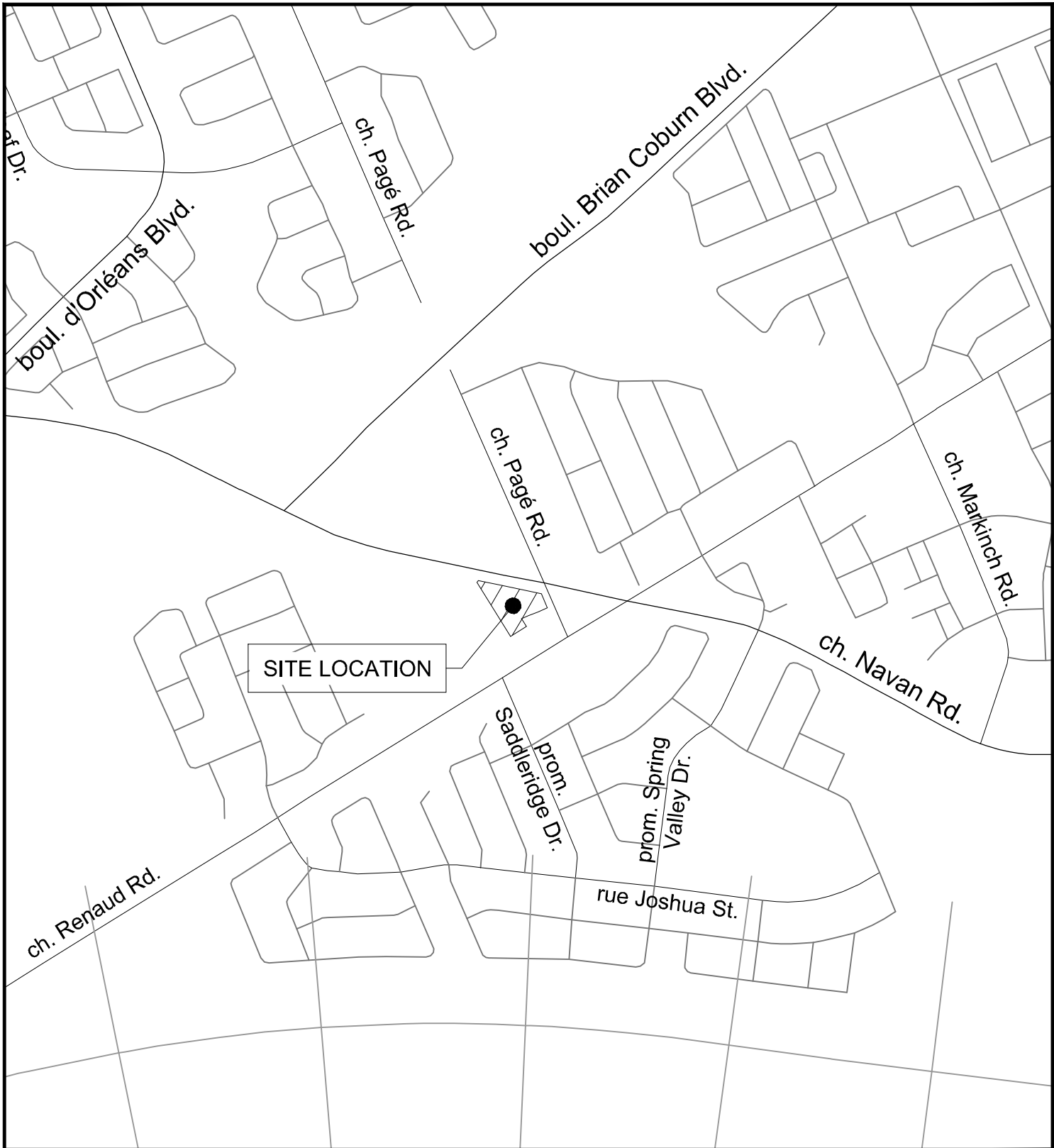
The site is bound by Navan Road to the north, Paige Road to the east, existing residential dwellings, and Renaud Road to the south, and Falsetto Street and the Caivan Rhythm development to the west. The site primarily drains from the north-east to the south-west with a +/- 1.4m grade differential across the site. **Figure 2** shows the existing site conditions.

The Caivan Rhythm residential development was designed by Urbantech Consulting. (Urbantech) and design information is provided in the following report:

- 'Design Report and Stormwater Management Brief Caivan Rhythm Residential Development, 2980, 3048, 3054 and 3080 Navan Rd. and 6101 Renaud Rd, prepared By Urbantech dated August 2022 – 7<sup>th</sup> Submission (Referenced as Urbantech Report).

### 1.2 Proposed Development

It is proposed to develop the site with a six (6) storey apartment building complete with above ground parking and an underground parking structure. The building will have a footprint of 1892.62m<sup>2</sup>, with a total of 119 residential units, and a 100m<sup>2</sup> site rental office on the ground floor. Vehicular access to the site will be provided from Falsetto Street while pedestrian access will be provided from both Falsetto Street and Navan Road. **Figure 3** shows the concept plan for the proposed development. Correspondence from the City pre-consultation meeting for the proposed development is also included in **Appendix A** for reference.



SITE LOCATION



Engineers, Planners & Landscape Architects  
 Suite 200, 240 Michael Cowpland Drive  
 Ottawa, Ontario, Canada K2M 1P6

Telephone (613) 254-9643  
 Facsimile (613) 254-5867  
 Website www.novatech-eng.com



CITY OF OTTAWA  
 3080 NAVAN ROAD

KEY PLAN

SCALE N.T.S

DATE	JAN 2023	JOB	122180	FIGURE	FIGURE 1
------	----------	-----	--------	--------	----------





**LEGEND**

--- SITE BOUNDARY

**NOVATECH**

Engineers, Planners & Landscape Architects  
Suite 200, 240 Michael Cowpland Drive  
Ottawa, Ontario, Canada K2M 1P6

Telephone (613) 254-9643  
Facsimile (613) 254-5867  
Website www.novatech-eng.com

CITY OF OTTAWA  
3080 NAVAN ROAD

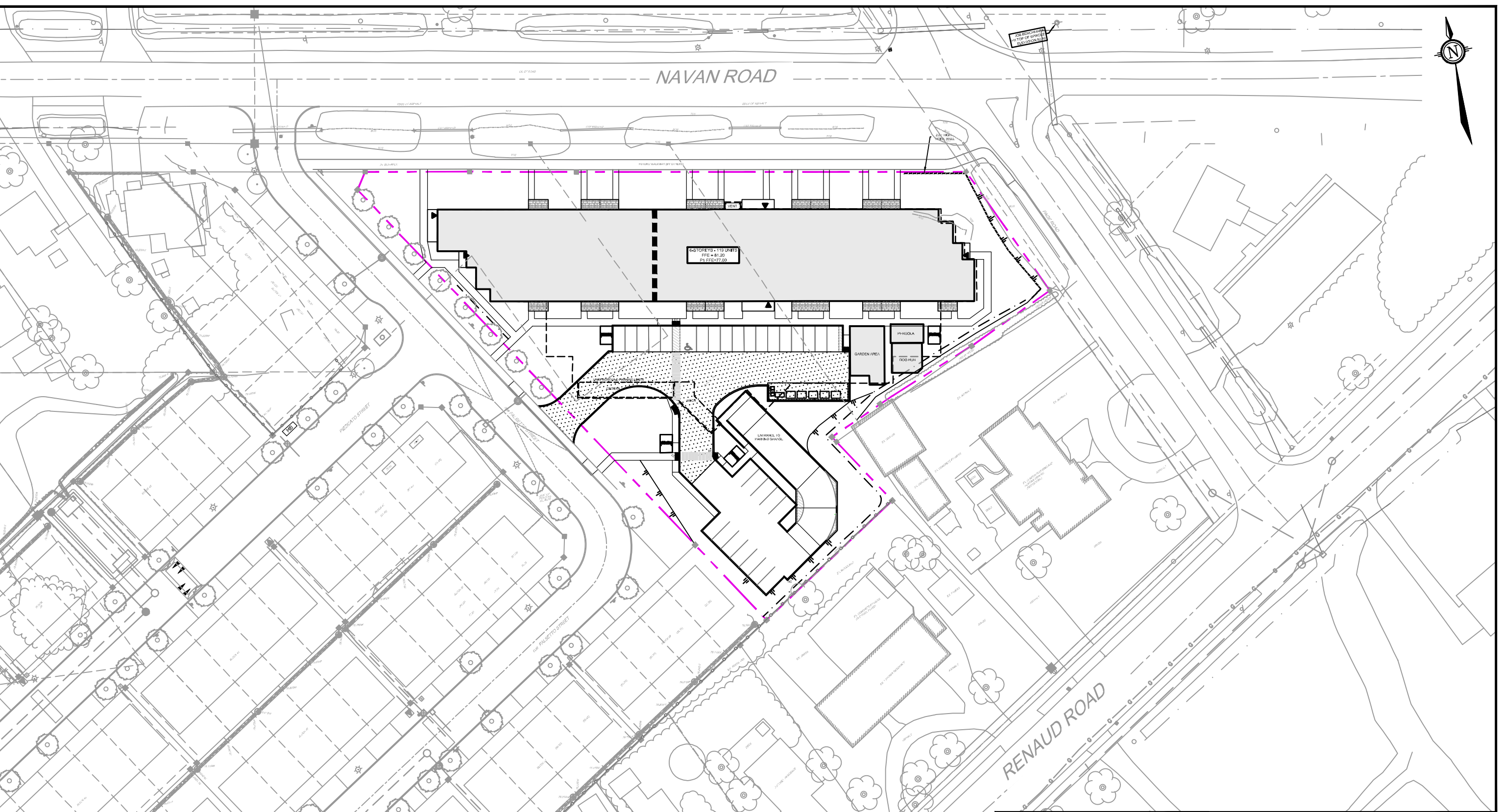
**EXISTING CONDITIONS**

SCALE 1 : 500 0 5m 10m 20m


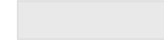

DATE JAN 2023 JOB 122180 FIGURE FIGURE 2



M:\2022\122180\CAD\Civil\Figures\Design Brief\122180-Siteplan Figure.dwg, SP, Apr 26, 2023 - 3:18pm, amestwarp




**LEGEND**

	SITE BOUNDARY
	BUILDING HATCH
	PATIO HATCH

**NOVATECH**  
 Engineers, Planners & Landscape Architects  
 Suite 200, 240 Michael Cowpland Drive  
 Ottawa, Ontario, Canada K2M 1P6  
 Telephone (613) 254-9643  
 Facsimile (613) 254-5867  
 Website www.novatech-eng.com

CITY OF OTTAWA  
 3080 NAVAN ROAD

**SITE PLAN**

SCALE	1 : 750		
DATE	AUGUST 2023	JOB	122180
FIGURE	FIGURE 3		

## 2.0 SITE CONSTRAINTS

A geotechnical investigation was completed for the Caivan Rhythm development, and a report prepared entitled 'Geotechnical Investigation', Proposed Apartment Building Development, 3080 Navan Road, Ottawa Ontario prepared by Paterson Group Inc. dated March 22, 2023 (PG6527-1,). The following is a summary of the findings of the report:

- The long-term groundwater table can be expected at a depth of approximately 2 to 3 m throughout the subject site. It should be noted that groundwater levels are subject to seasonal fluctuations. Therefore, the groundwater levels could vary at the time of construction.
- Existing foundation walls and other construction debris should be entirely removed from within the building perimeter. Under paved areas, existing construction remnants, such as foundation walls, should be excavated to a minimum of 1 m below final grade.
- It is expected the site will be underlain by a deposit of silty clay. Therefore, a permissible grade raise restriction of 80.70 is recommended for the North half of the site and 81.0 m is recommended for the south half of the site.
- The excavation side slopes above the groundwater level extending to a maximum depth of 3 m should be cut back at 1H:1V or flatter. The flatter slope is required for excavation below groundwater level. The subsurface soil is considered to be mainly a Type 2 and Type 3 soil according to the Occupational Health and Safety Act and Regulations for Construction Projects.
- To reduce long-term lowering of the groundwater level at this site, clay seals should be provided in the service trenches.
- A temporary Ministry of Environment, Conservation and Parks (MECP) permit to take water (PTTW) may be required if more than 400,000 L/day of ground and/or surface water are to be pumped during the construction phase.
- For typical ground or surface water volumes being pumped during the construction phase, typically between 50,000 to 400,000 L/day, it is required to register on the Environmental Activity and Sector Registry (EASR).
- Based on the results of the Atterberg limit testing, the plasticity index was found to be greater than 40% in all the tested clay samples. Based on this, the clay is considered to be a clay of high potential for soil volume change. Refer to the Geotechnical Report for tree planting recommendations.
- The annual probability of a large catastrophic landslide occurring at or directly impacting the subject site was determined to be less than 1:10,000 per annum.
- Due to the low permeability of the subgrade materials consideration should be given to installing subdrains during the pavement construction as per City of Ottawa standards.

### 3.0 WATER SERVICING

There are existing City watermains in all rights-of-way fronting the proposed site. There is an existing 300mm diameter (dia.) watermain within Paige Road, a 300mm dia. watermain in Navan Road, and a 300mm dia. watermain within Falsetto Street that was installed as part of the Caivan Subdivision. As part of the Caivan subdivision construction two (2) 200mm diameter water services were installed near the south-west corner of Block 64 from the Falsetto Street watermain.

It is proposed to service the proposed development with the two (2) 200mm diameter services that were installed as part of the Caivan Subdivision. The proposed building will be sprinklered and equipped with a Siamese connection located near the front entrance within 45m of a fire hydrant. Refer to the General Plan of Services drawing (122120-GP) for servicing details.

Water demand calculations have been calculated using criteria from Section 4 of the City of Ottawa Water Distribution Guidelines and the Ontario Building Code. The required fire demand was calculated using the Fire Underwriters Survey (FUS) Guidelines. The water demand and fire flow calculations are provided in **Appendix B** for reference. A summary of the water demand and fire flows are provided in **Table 3.1**.

**Table 3.1: Domestic Water Demand Summary**

Population	Commercial Area (m <sup>2</sup> )	Ave. Daily Demand (L/s)	Max. Daily Demand (L/s)	Peak Hour Demand (L/s)	Fire Flow (L/s)
252	100	0.83	2.06	4.51	300

The above water demand information was submitted to the City for boundary conditions from the City’s water model. These boundary conditions were used for analyzing the performance of the proposed and existing watermain systems for three theoretical conditions:

- 1) High Pressure check under Average Day conditions
- 2) Peak Hour demand
- 3) Maximum Day + Fire Flow demand.

Refer to **Table 3.2** for a summary of the proposed boundary conditions and hydraulic analysis.

**Table 3.2: Water Boundary Conditions and Hydraulic Analysis Summary**

Criteria	Head (m)	Pressure <sup>1</sup> (psi)	Pressure Requirements (psi)
<b>Connection (300mm dia. Falsetto Street)</b>			
Max HGL	130.7	70.4	< 80psi
Min HGL	126.8	64.8	> 40psi
Max Day + Fire Flow	112.4	44.4	> 20psi

<sup>1</sup>Pressure based on a Finished Floor elevation of 81.20m

The hydraulic analysis indicates that the system can provide adequate pressures and flow to meet the domestic and fire flow requirements for the site. Refer to **Appendix B** for detailed water demand calculations, and City of Ottawa boundary conditions.

#### 4.0 SANITARY SERVICING

There is an existing 250mm diameter sanitary sewer, and a 300mm and 400mm diameter Sanitary forcemain within the Paige Road right-of-way, and a 200mm diameter sanitary sewer within Falsetto Street that was installed as part of the Caivan Subdivision. As part of the subdivision construction a 200mm diameter sanitary service was installed near the south-west corner of Block 64 from the Falsetto Street Sanitary Sewer.

It is proposed to service the proposed development with the service that was installed as part of the Caivan Subdivision.

Sanitary flows for the proposed development were calculated using criteria from Section 4 of the City of Ottawa Sewer Design Guidelines and the Ontario Building Code as follows:

- Residential Average Flow = 280 L/capita/day
- 1 Bed apartment = 1.4 Person/unit
- 2 Bed apartment = 2.1 Person/unit
- Commercial flow = 75 L/9.3m<sup>3</sup>/day
- Residential Peaking Factor = Harmon Equation (max peaking factor = 4.0)
- Commercial Peaking Factor = 1.0
- Peak Extraneous Flows (Infiltration) = 0.33L/s/ha

The peak sanitary flow including infiltration for the development was calculated to be 3.10 L/s. Detailed sanitary flow calculations are provided in **Appendix C** for reference.

As noted previously, the detailed design of the Caivan Subdivision was completed by Urbantec with details provided within the Urbantec Report. The Subdivision design assumed that block 64 was to be a residential development with 150 units, and no commercial area for a total assumed population of 285. The design criteria are summarized below, and excerpts from the report are included within **Appendix C** for reference.

- Average Daily Flow = 280 L/capita/day
- Residential Peaking Factor = Harmon Equation (max peaking factor = 4.0)
- Commercial/ Institutional Peaking Factor = 1.0
- Peak Extraneous Flows (Infiltration) = 0.33L/s/ha

The resultant assumed flow for block 64 was 3.4L/s. The assumed design flow was higher than currently proposed, thus the existing infrastructure within the Caivan Subdivision has capacity to service the proposed development.

## 5.0 STORM SERVICING

There is a 450m storm sewer located within the Falsetto Street right-of-way fronting to the proposed development. From the Falsetto Street right of way there is a 375mm diameter stub in the south-west corner of the development that was installed as part of the Caivan Subdivision. The remaining rights-of-ways surrounding the development are serviced by open-ditch systems.

It is proposed to service the proposed development with the service that was installed as part of the Caivan Subdivision. From the existing stub a private storm system will be installed that will provide two (2) 250mm diameter building connections. One (1) storm service will convey the uncontrolled foundation drain, and the controlled roof drain flows, while the second service will convey the controlled flows from the internal stormwater cistern within the parking garage. The existing HGL within Falsetto Street is 77.60m during the 100-yr storm event, and both services have been designed to be above this elevation at the building connection. Refer to the General Plan of Services drawing (122180 - GP) for more details.

The design criteria used in sizing the storm sewers are summarized below in **Table 5.1**.

**Table 5.1: Storm Sewer Design Parameters**

Parameter	Design Criteria
Local Roads	2 Year Return Period
Storm Sewer Design	Rational Method
IDF Rainfall Data	Ottawa Sewer Design Guidelines
Initial Time of Concentration (Tc)	10 min
Minimum Velocity	0.8 m/s
Maximum Velocity	3.0 m/s
Minimum Diameter	250 mm

Refer to **Appendix D** for detailed storm drainage area plans and storm sewer design sheets.

## 6.0 STORM DRAINAGE AND STORMWATER MANAGEMENT

The stormwater management strategy for the site is based on the established criteria from the City of Ottawa, and the Urbantech Report.

### 6.1 Design Criteria

Through correspondence with the City of Ottawa, the Urbantech Report and our knowledge of development requirements in the area, the following criteria have been adopted to control post-development stormwater discharge from the site:

- Control proposed development flows, up to and including the 100-year storm event, to an allowable release rate of 85L/s/ha



- Provide source controls which are in conformity with the City of Ottawa requirements, where possible;
- Limit ponding to 0.15 m for all rooftop storage areas and 0.30 m for all parking storage areas;
- Ensure no surface ponding during the 2-year Storm event; and
- Provide guidelines to ensure that site preparation and construction is in accordance with the current Best Management Practices for Erosion and Sediment Control.

The approach to the stormwater management design is to determine the allowable release rate for the site, calculate the uncontrolled flow, and ensure that the remaining flow, in combination with the uncontrolled flow, does not exceed the allowable release rate. All proposed development runoff in excess of the allowable release rate, will be attenuated on-site prior to being released into the storm sewers within Falsetto Street.

## 6.2 Quantity Control

The allowable release rate for the 0.67 ha site was calculated to be 56.9 L/s based on the SWM criteria provided by the City of Ottawa, and the Urbantech Report.

### Design Storms

The design storms are based on City of Ottawa design storms. Design storms were used for the 5, 100, and 100+20%-year return periods (i.e. storm events).

### Model Parameters

Post-development catchments were modelled based on the proposed site plan and grading as shown on **Drawing 122180-SWM** within **Appendix D**. The building roofs were assumed to have no depression storage.

The site has been divided into sixteen (16) drainage areas for the post development condition. The drainage areas are as follows:

#### **Area A-01**

- Flows from the proposed garage access, central parking area and outdoor amenity areas will be conveyed to the existing storm sewer in Falsetto Street. These flows will be captured by area drains, and a trench drain which will be conveyed to the proposed cistern located within the underground parking structure. Flows from the cistern to the existing sewer in Falsetto Street will be controlled by an inlet control device (ICD), and the flows will drain by gravity to the existing sewer system. The storm service will be equipped with a backflow prevention device to protect the building from any potential sewer back-ups. Storage will be provided for storms up to and including the 100-year event within the cistern. A 150mm internal overflow is provided at the 100-yr water elevation, and a vented lid is proposed on the tank for maintenance access and emergencies which will convey flows directly to the Falsetto Street right-of-way.

**Area R-01-08:**

- Stormwater from the building roof will be captured and controlled by flow control roof drains prior to releasing to the storm sewer in Falsetto Street. The ponding will be limited to 0.15m in depth with overflow scuppers provided for emergencies. Storage of stormwater will be provided for storms up to and including the 100-year event. Further details will be provided once a mechanical consultant is retained for the subject development.

**Area A-02:**

- Stormwater from the parking area not over the underground parking structure will be captured and controlled by a proposed catch basin manhole. Flows from the catch basin to the existing sewer in Falsetto Street will be controlled by an inlet control device (ICD), and the flows will drain by gravity to the existing sewer system.

**Area D-01:**

- The drainage along the north frontage of the property will flow uncontrolled to the Navan Road right-of-way, where it will be captured by the existing open ditch system.

**Area D-02:**

- The drainage along the east frontage of the property will flow uncontrolled to the Page Road right-of-way, where it will be captured by the existing open ditch system.

**Area D-03**

- The drainage along the west frontage of the property will flow uncontrolled to the Falsetto Street right-of-way, where it will be captured by the existing storm system.

**Area D-04, Ex-01:**

- The drainage along the south frontage of the property, and the neighboring external drainage area will flow uncontrolled to the proposed Catch basin 01, where it will be conveyed to the existing storm system within Falsetto Street.

**Area Ex-02:**

- The external drainage area to the south-east of the property as noted within the Urbantech report will be directed along the property line to the existing ditch system on page road. After a review of the site topographic data and historic street images it was determined that the existing drainage flows along the property line beneath the existing hedge to the existing open ditch system on Page Road, and not through the subject property as noted in the Urbantech Report. Refer to **Figure 4** for details.

Table **6.1 below** summarizes the flow, storage required, and storage provided for each of the site drainage areas.



# Existing Drainage Swale

FIGURE 4

**Legend**  
📍 Marcel Brazeau





Table 6.1: Stormwater Management Summary

Area ID	Area (ha)	1:5 Year Weighted Cw	1:100 Year Weighted Cw	Control Device		Outlet Location	2 Year Storm Event				5 Year Storm Event				100 Year Storm Event			
							Release (L/s)	Ponding Depth* (m)	Req'd Vol (cu.m)	Max. Vol. Provided (cu.m.)	Release (L/s)	Ponding Depth* (m)	Req'd Vol (cu.m)	Max. Vol. Provided (cu.m.)	Release (L/s)	Ponding Depth* (m)	Req'd Vol (cu.m)	Max. Vol. Provided (cu.m.)
D-01	0.092	0.30	0.35	N/A		Navan Road	5.9	N/A	N/A	N/A	8.0	N/A	N/A	N/A	16.20	N/A	N/A	N/A
D-02	0.006	0.20	0.25	N/A		Page Road	0.3	N/A	N/A	N/A	0.4	N/A	N/A	N/A	0.80	N/A	N/A	N/A
D-03	0.024	0.39	0.46	N/A		Falsetto Street	2.0	N/A	N/A	N/A	2.7	N/A	N/A	N/A	5.40	N/A	N/A	N/A
D-04	0.026	0.20	0.25	N/A		Falsetto Street	1.1	N/A	N/A	N/A	1.5	N/A	N/A	N/A	3.20	N/A	N/A	N/A
R-01	0.013	0.90	1.00	Accutrol RD-100-A-ADJ	1/4 Open	Falsetto Street	0.73	0.08	1.16	6.24	0.78	0.10	1.82	6.24	0.89	0.13	4.43	6.24
R-02	0.033	0.90	1.00	Accutrol RD-100-A-ADJ	3/4 Open	Falsetto Street	1.07	0.10	4.00	13.73	1.12	0.11	6.04	13.73	1.57	0.15	12.81	13.73
R-03	0.033	0.90	1.00	Accutrol RD-100-A-ADJ	1/2 Open	Falsetto Street	0.93	0.10	4.36	14.98	1.01	0.11	6.41	14.98	1.23	0.15	14.22	14.98
R-04	0.028	0.90	1.00	Accutrol RD-100-A-ADJ	1/4 Open	Falsetto Street	0.77	0.10	3.69	13.66	0.81	0.11	5.49	13.66	0.92	0.14	12.41	13.66
R-05	0.028	0.90	1.00	Accutrol RD-100-A-ADJ	1/4 Open	Falsetto Street	0.77	0.10	3.69	13.66	0.81	0.11	5.49	13.66	0.92	0.14	12.41	13.66
R-06	0.036	0.90	1.00	Accutrol RD-100-A-ADJ	1/4 Open	Falsetto Street	0.78	0.10	5.31	17.34	0.83	0.11	7.82	17.34	0.91	0.15	17.33	17.34
R-07	0.038	0.90	1.00	Accutrol RD-100-A-ADJ	3/4 Open	Falsetto Street	1.09	0.10	5.00	16.56	1.21	0.11	7.31	16.56	1.54	0.15	16.00	16.56
R-08	0.009	0.90	1.00	Accutrol RD-100-A-ADJ	1/4 Open	Falsetto Street	0.71	0.08	0.62	4.39	0.75	0.09	1.03	4.39	0.86	0.13	2.62	4.39
A-02	0.058	0.76	0.85	Tempest LMF 75		Falsetto Street	6.30	1.600	1.92	20.10	6.85	1.860	3.56	20.10	7.00	1.950	11.36	20.10
Cistern	0.243	0.64	0.72	LMF 105		Falsetto Street	6.60	0.450	26.44	95.69	7.14	0.535	38.38	95.69	11.00	1.225	78.81	95.69
<b>Post-Development Flow</b>							<b>29.0</b>	<b>-</b>	<b>56.2</b>	<b>120.7</b>	<b>33.9</b>	<b>-</b>	<b>83.3</b>	<b>120.7</b>	<b>52.4</b>	<b>-</b>	<b>182.4</b>	<b>120.7</b>
<b>Total Allowable Release Rate</b>							<b>56.9</b>				<b>56.9</b>				<b>56.9</b>			

\* Ponding depth is measured from the control device

Refer to **Appendix D** for Rational Method calculations and **Drawing SWM**-Stormwater Management Plan.

**6.3 Major Overland Flow Route**

A major overland flow route will be provided for storms greater than the 100-year storm event. Stormwater will be directed to the surrounding rights-of-way, and the rear yard swale of the adjoining subdivision. The major overland system is shown on the Grading Plan (drawing 122180-GR).

**6.4 Cistern Operation and Maintenance**

The cistern will need to undergo regular inspections (yearly) for maintenance verification. Access will be from the clean-out lid located on the south-east portion of the cistern. Below is suggested list of items to inspect during yearly maintenance verification.

**Table 6.2: Cistern Routine Inspection List**

Parameter	Inspection
Roof Drains	Remove any natural debris blocking flow to drains.
Sump	Remove all debris and sediment.
Inlet	Check for obstructions and remove debris and sediment.
Access Lid	Inspect for damage, obstruction, and accessibility
Cistern Structure	Inspect for damage or leaking.
Overflow Outlet	Check for obstructions and remove debris and sediment.

**7.0 EROSION AND SEDIMENT CONTROL**

Temporary erosion and sediment control measures will be implemented on-site during construction in accordance with the Best Management Practices for Erosion and Sediment Control. This includes the following temporary measures:

- Filter socks (catchbasin inserts) will be placed in existing and proposed catchbasins and catchbasin manholes, and will remain in place until vegetation has been established and construction is completed;
- Silt fencing will be placed along the surrounding construction limits;
- Mud mats will be installed at the site entrances;
- Strawbale or rock check dams will be installed in swales and ditches;
- The contractor will be required to perform regular street sweeping and cleaning as required, to suppress dust and to provide safe and clean roadways adjacent to the construction site;

Erosion and sediment control measures should be inspected daily and after every rain event to determine maintenance, repair or replacement requirements. Sediments or granulars that enter site sewers shall be removed immediately by the contractor. These measures will be implemented prior to the commencement of construction and maintained in good order until vegetation has been established. Refer to the Erosion and Sediment Control Plan (drawing 122180-ESC) for additional information.

## 8.0 CONCLUSIONS AND RECOMMENDATIONS

### Watermain

The analysis of the existing and proposed watermain network confirms the following:

- The proposed 200mm dia. watermain service which connects to the existing 200mm watermain stubs from Falsetto Street can service the proposed development.
- There are adequate pressures in the existing watermain infrastructure to meet the required domestic demands for the development.
- There is adequate flow to service the proposed fire protections system.

### Sanitary Servicing

The analysis of the existing and proposed sanitary system confirms the following:

- It is proposed to service the development with a proposed 200mm Sanitary service which will connect to existing sewers within the Falsetto Street Avenue right-of-way.
- It is anticipated there is adequate capacity within the existing sanitary infrastructure to service.

### Stormwater Management

The following provides a summary of the storm sewer and stormwater management system:

- The proposed storm sewer system is to connect to the storm sewers within in the Falsetto Street Avenue right-of-way.
- Stormwater control is to be provided by rooftop storage, parking lot storage, and a cistern within the P1 parking level.
- Storm flows will be attenuated through the implementation of inlet control devices.
- As per existing conditions a major overland flow routes have been provided to the surrounding rights-of-way.

### Erosion and Sediment control

- Erosion and sediment control measures (i.e. filter fabric, catch basin inserts, silt fences, etc.) will be implemented prior to construction and are to remain in place until vegetation is established.

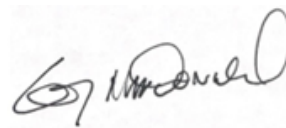
**9.0 CLOSURE**

The preceding report is respectfully submitted for review and approval. Please contact the undersigned should you have questions or require additional information.

**NOVATECH**

**Prepared by:**

**Reviewed by:**



**Anthony Mestwarp, P.Eng  
Project Manager  
Land Development Engineering**

**Greg MacDonald, P.Eng  
Director, Land Development and Public  
Sector Infrastructure**

**Appendix A**  
**Pre - Consultation Meeting Minutes**



3080 Navan Road (Block 64 on Draft 4M-Plan) – Pre-application Consultation Notes  
(Ward 2– Innes)

Meeting Date: Tuesday, May 12, 2022

Attendees	Phil Castro, Parks Planner, City of Ottawa Will Curry, Project Manager (Infrastructure), City of Ottawa Mike Giampa, Project Manager (Transportation), City of Ottawa Ann O’Connor, Planner (Urban Design), City of Ottawa Lucy Ramirez, Planner (Development Review), City of Ottawa Virginia Johnson, LRL Engineering Marcus Joseph, Seymour Pacific Eric Forhan, JLR Richards Trevor Dickie, Broadstreet Rachel Ricard, Seymour Pacific
Regrets	Jamie Batchelor, Planner, RVCA Mark Richardson, Forester – Planning, City of Ottawa Evode Rwagasore, Planner Sami Rehman, Environmental Planner, City of Ottawa

Contents

Proposal Summary ..... 2

Planning..... 2

    Minor Variance..... 4

    Applications Fees – Site Plan Complex ..... 5

    High Performance Development Standard..... 5

    ADS Site Plan Checklist..... 6

Engineering Comments ..... 6

Rideau Valley Conservation Authority (RVCA) ..... 7

Transportation Comments ..... 8

Forestry Comments ..... 8

Parkland Dedication..... 11

Urban Design..... 11

Attachments:..... 13

## Proposal Summary



The proposal is for six storey apartment building (107 units) with an underground podium parkade and surface parking (163 spaces). Please note where the bicycle parking is located and how many spaces are provided.

The Applicant is encouraged to review and incorporate design elements from the City's Bird Safe Design Guidelines into the proposal.

### Planning

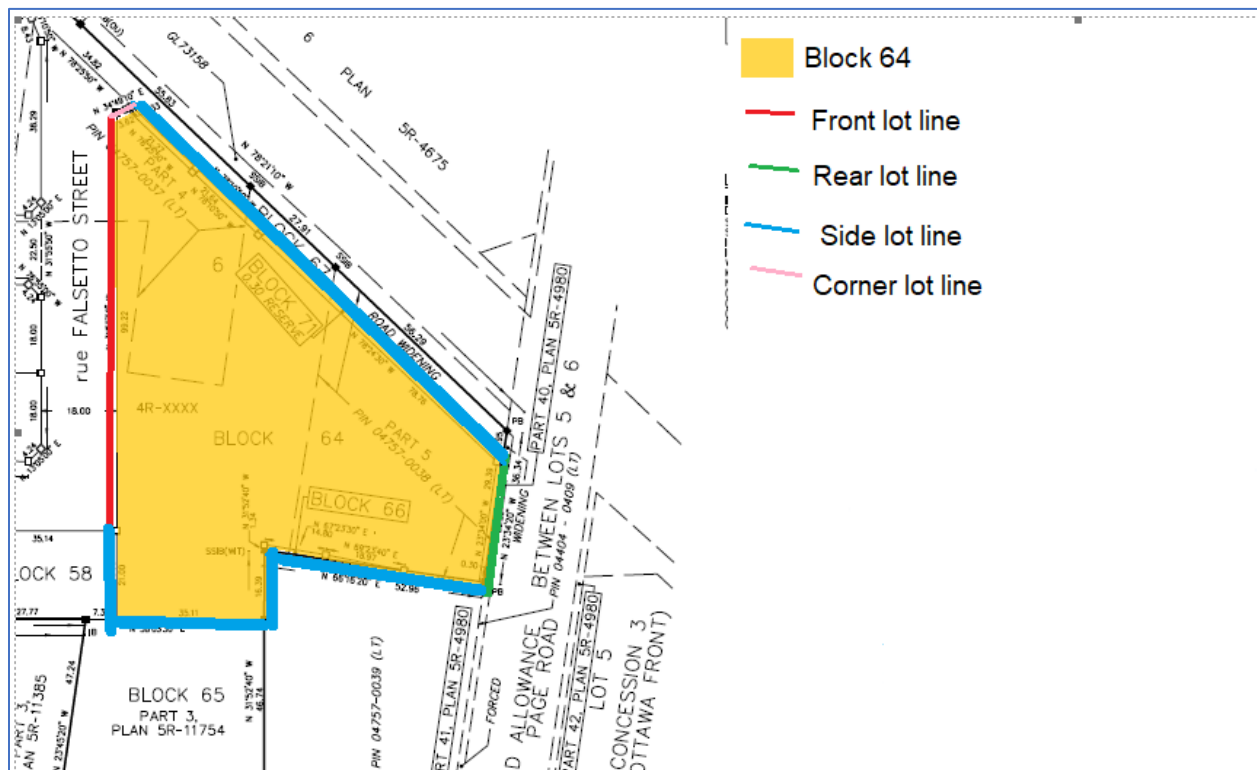
The subject property (Block 64 of Draft 4M Plan of Subdivision) is designated General Urban Area on Schedule B of the existing *Official Plan* (2003 consolidation). In the new *Official Plan* is in the Suburban Transect per schedule A and Neighbourhood Designation per Schedule B8. The Property is within the limits of the East Urban Community Phase 1 Community Design Plan. The property is identified as "Existing Residential" (Figure 14, Demonstration Plan). The property is Block 64 on a draft plan of subdivision (application [D07-16-20-003](#)). The property is within 600 metre of the Chapel Hill rapid transit station. Block 64 is irregularly shaped and there are 30 cm reserves along Navan and Page Road, which impact the lot lines.

## Zoning

The site is zoned R5N [2744] H20 which currently permits mid-rise residential buildings with a max height of 20 metres

There are 30 cm reserves showing abutting Navan and Page. This changes which line is considered the front lot line. Below is my interpretation regarding the lot lines, Zoning Interpretation Staff have confirmed my interpretation.

- The front lot line would be Falsetto Street,
- The rear lot line would be Page Road, which may be closed in the future.
- The lot line abutting Navan would be a side lot line, as would the lot lines abutting Block 65 and the existing dwelling on the adjacent parcel.



Lot line means the boundary of a lot, and includes:

- a. front lot line which means that lot line, not including a corner lot line, which abuts a street for the shortest distance, whether or not that line jogs or curves, and extending between the side lot lines, more or less for the full width of the lot, and where more than one such lot line exists, means a lot line which abuts the same street as the front lot line of an abutting lot; (By-law 2008-462)
- b. rear lot line which means the lot line furthest from and opposite the front lot line but if there is no such line, that point furthest from and opposite the front lot line; and
- c. side lot line which means a lot line other than a front lot line, a corner lot line, or a rear lot line. (By-law 2008-462)
- d. corner lot line which means that lot line that abuts a street and is also one line of a conveyed corner sight triangle, or a sight triangle included as part of a road on a plan of subdivision. (ligne de lot) (By-law 2008-462)

## Minor Variance

---

As proposed, a minor variance is required for the rear yard setback, which abuts Pagé Road. Staff view this as a technical minor variance and has no concern with a minor variance to permit a 3 metres setback, whereas the By-law requires 7.5 metres.

### *Four Tests*

The Committee of Adjustment is authorized to grant a minor variance if all of the following criteria, commonly referred to as the 'four tests', are met:

- a. The variance is minor;
- b. The variance is desirable for the appropriate development or use of the property;
- c. The general intent and purpose of the Zoning By-law is maintained;
- d. The general intent and purpose of the Official Plan is maintained.

A requirement of a minor variance application is a detailed cover letter and/or report explaining the nature of the application and addressing the four tests of the *Planning Act*. In the rationale, in addition to the first two tests you should also explain how you are meeting the general intent and purpose of the Zoning By-law as well as the *Official Plan*.

### *Committee of Adjustment*

Please note that Minor Variance applications are handled by the Committee of Adjustment. The Planning Department provides comments on Committee of Adjustment applications; however, the Committee of Adjustment makes the decision.

For minor variance applications that are tied to Site Plan Applications, the Committee likes to see the applications once the Site Plan process is well underway and the application is through a few rounds of comments.

For more information on the Committee of Adjustment, including application forms and fees, please visit: <https://ottawa.ca/en/city-hall/planning-and-development/committee-adjustment>. For questions pertaining to forms and fees, please contact the Committee of Adjustment directly at [cofa@ottawa.ca](mailto:cofa@ottawa.ca) or at (613)-580-2436. The application form contains the mandatory submission requirements such as a Survey Plan, Site Plan, Elevations.

I've attached a high-level backgrounder on the minor variance process.

### *Timelines*

I can shed some light on typical Committee of Adjustment timelines. The Committee of Adjustment process typically takes approximately 12 to 14 weeks from application submission to the end of the appeal period. My understanding is that once your application has been deemed complete it takes four to six weeks before the application is heard at a Committee meeting. The Committee meeting is the official public meeting; however, the Committee strongly recommends

applicants consult with the public beforehand. As of June 3, 2020, meetings have been taking place via Zoom. I'll note that discussions are underway regarding a return to in person meetings.

#### *Public Consultation*

Please speak to the neighbours regarding your plans. We recommend that you contact the neighbours and let them know what you are proposing. Neighbours within 60m of the property receive a public notice. Anyone from the public is permitted to voice their comments or concerns at the Committee of Adjustment meeting regarding your application, so it is a good idea to speak to neighbours in advance.

#### Applications Fees – Site Plan Complex

---

Please see additional information related to the City's [Development Application Fees](#) including information related to reductions for multiple applications, on-site signs, re-circulations, Ontario Land Tribunal City Legal Costs as well as refunds.

##### 1. [Site Plan Control Approval – Complex](#)

\$46,782.80 Complex + legal fees (\$2,816.00 + HST) = **\$ 49,964.88**  
+ Initial Engineering Design Review and Inspection Fee, Ranges from \$1000 to \$10,000 dependent on value of hard and soft servicing + Conservation Authority Fee (\$1,065.00).

**Note 1:** Additional Engineering Design Review and Inspection Fees of 4.5 % of the value of the hard servicing (road, sewers, watermains, sidewalks, curbs, stormwater, etc.) and 2.25 % of the soft servicing (lot grading, sodding, driveway treatment etc.) are payable prior to the registration and should be forwarded to the Assigned Staff. The Engineering Design Review and Inspection Flat Rate Fee collected at submission will be credited to these fees. If the Site Plan process does not involve an agreement the Engineering Design Review and Inspection Fee is required prior to Site Plan Approval.

**Please note these are the 2022 fees, fees increase every year.**

#### High Performance Development Standard

---

The High Performance Development Standards (HPDS) were passed by Council on April 13, 2022. The HPDS will set performance targets for new construction to achieve sustainable development and climate change goals.

The High-Performance Development Standard (HPDS) is a collection of mandatory and voluntary standards or “metrics” that raise the performance of new building projects to achieve “sustainable and resilient design” objectives. The HPDS consists of three tiers of performance.

Once the new Official Plan is provincially approved and in effect, they apply to new site plan and plan of subdivision applications.

I'm attaching a handout for your information (Attachment 3).

ADS Site Plan Checklist

---

I've attached the City of Ottawa Accessible Design Standards (ADS) Site Plan Checklist (Attachment 4), the City recommends development be in accordance with these standards on private property and development has to be in accordance with these standards for any land that will be conveyed to the City as part of a development application. Please ensure the accessibility requirements are implemented (where applicable).

Engineering Comments

**Required Request:**

Water Boundary condition requests must include the location of the service and the expected loads required by the proposed development. Please provide the following information:

Location of service connections (**MAP**)

Type of development and the amount of fire flow required (as per FUS).

Average daily demand: \_\_\_ l/s.

Maximum daily demand: \_\_\_ l/s.

Maximum hourly daily demand: \_\_\_ l/s.

---

**Submission:**

Site Plan

Topographical Plan of Survey Plan with a published Benchmark

Demolition Plan (if required)

Grading & Drainage Plan

General Plan of Services

Erosion & Sediment Control Plan

Catchment Plan (post)

Stormwater Management & Design Brief Report

Geotechnical Report (updated)

TCR & Landscape Plan

---

**Minimum Drawing and File Requirements- All Plans**

Plans are to be submitted on standard **A1 size** (594mm x 841mm) sheets, utilizing an appropriate Metric scale (1:200, 1:250, 1:300, 1:400, or 1:500).

With all submitted hard copies provide individual PDF of the DWGs and for reports please provide one PDF file of the reports.

All PDF documents are to be unlocked and flattened. No reports submitted to be older than 5 years.

---

Design Criteria - Civil Engineer to contact me directly if need be William Curry  
[william.curry@ottawa.ca](mailto:william.curry@ottawa.ca)

Site Target Release Rate is 85 L/s/ha, actual to be calculated.

Onsite; No 2-year ponding on site. Store up to 100-year onsite.

Permissible ponding of 350mm for 100-year. No spilling to adjacent sites.

At 100-year ponding elevation you must spill to City ROW

100-year Spill elevation must be 300mm lower than any building opening

Water servicing requires looping as you are over 50 units.

---

The City reserves the right to make changes to any decisions made herein should new information or data present other information.

[Rideau Valley Conservation Authority \(RVCA\)](#)

### **Natural Hazards**

Conservation Authorities were delegated natural hazard responsibilities by the Minister of Natural Resources (now known as Ministry of Natural Resources and Forestry). This includes flood plain management, hazardous slopes, Great Lakes shorelines, unstable soils and erosion which are now encompassed by Section 3.1 "Natural Hazards" of the Provincial Policy Statement.

The proposed development is adjacent a slope and in some instances is proposed within a slope which forms part of an existing escarpment. The site has been identified as having the potential for "Unstable Slopes" on Schedule K of the City's Official Plan. The site has also been identified as being within a historical landslide scar based on information documented by the Geological Survey of Canada. Based on the information available, it would appear that the landslide extended over 200 metres beyond the original escarpment face with portions of the debris field within this site. A second historical landslide has been documented along the same escarpment approximately 1 km from this site, while several former landslides and smaller landslides have been documented along the same escarpment within 2 km from the site. Therefore, there is a well documented history of landslides occurring along the escarpment within this site and adjacent this site.

We note that this site plan is for a block within an approved draft plan of subdivision. As part of the draft plan of subdivision, the applicant had provided a landslide risk assessment. The report has been per reviewed by BGC Engineering. While the peer



review agreed with the ultimate conclusion, the rationale provided to substantiate the conclusion was not accepted. This led to a condition of draft approval requiring that a revised landslide hazard assessment be submitted and approved prior to registration. It is our understanding that the applicant is working towards satisfying this condition. Therefore, as long as this condition is satisfied prior to the site plan control application, the Conservation Authority would have no additional requirements as it relates to landslide risk for this property. However, if it is the intention that this site plan control application move forward prior to the condition related to the revised landslide risk assessment being addressed, then we would ask that the proper documentation for landslide risk be submitted as part of this application.

### **Stormwater Management**

The stormwater management plan for this site must conform to the ultimate detailed stormwater management plan approved for registration of the draft plan of subdivision. Should the site plan move forward on an interim basis, then additional discussion is warranted.

If you have any questions, do not hesitate to contact me, Jamie Batchelor, MCIP, RPP

### **Transportation Comments**

1. A Traffic Impact Assessment (TIA) is warranted so please proceed to step 2 (scoping). Steps 3 and 4 can eventually be combined.
2. A road noise study is warranted (within 100m of Navan Road).
3. Navan Road has a right of protection of 37.5m.

### **Forestry Comments**

#### **Tree Conservation Report (TCR) requirements:**

1. a Tree Conservation Report (TCR) must be supplied for review along with the suite of other plans/reports required by the City
  - a. an approved TCR is a requirement of Site Plan approval.
  - b. The TCR may be combined with the EIS provided all information is supplied
2. Any removal of privately-owned trees 10cm or larger in diameter, or city-owned trees of any diameter requires a tree permit issued under the Tree Protection Bylaw (Bylaw 2020 – 340); the permit will be based on an approved TCR and made available at or near plan approval.
3. The Planning Forester from Planning and Growth Management as well as foresters from Forestry Services will review the submitted TCR
  - a. If tree removal is required, both municipal and privately-owned trees will be addressed in a single permit issued through the Planning Forester
  - b. Compensation may be required for city owned trees – if so, it will need to be paid prior to the release of the tree permit



4. the TCR must list all trees on site, as well as off-site trees if the Critical Root Zone extends into the developed area, by species, diameter and health condition
5. please identify trees by ownership – private onsite, private on adjoining site, city owned, co-owned (trees on a property line)
6. If trees are to be removed, the TCR must clearly show where they are, and document the reason they cannot be retained
7. All retained trees must be shown, and all retained trees within the area impacted by the development process must be protected as per City guidelines available at [Tree Protection Specification](#) or by searching Ottawa.ca
  - a. the location of tree protection fencing must be shown on the plan
  - b. show the critical root zone of the retained trees
  - c. if excavation will occur within the critical root zone, please show the limits of excavation
8. the City encourages the retention of healthy trees; if possible, please seek opportunities for retention of trees that will contribute to the design/function of the site.
9. For more information on the process or help with tree retention options, contact Mark Richardson [mark.richardson@ottawa.ca](mailto:mark.richardson@ottawa.ca) or on [City of Ottawa](#)

**LP tree planting requirements:**

For additional information on the following please contact [tracy.smith@Ottawa.ca](mailto:tracy.smith@Ottawa.ca)

**Minimum Setbacks**

- Maintain 1.5m from sidewalk or Multi Use Pathway/cycle track.
- Maintain 2.5m from curb
- Coniferous species require a minimum 4.5m setback from curb, sidewalk or MUP/cycle track/pathway.
- Maintain 7.5m between large growing trees, and 4m between small growing trees. Park or open space planting should consider 10m spacing, except where otherwise approved in naturalization / afforestation areas. Adhere to Ottawa Hydro's planting guidelines (species and setbacks) when planting around overhead primary conductors.

**Tree specifications**

- Minimum stock size: 50mm tree caliper for deciduous, 200cm height for coniferous.
- Maximize the use of large deciduous species wherever possible to maximize future canopy coverage
- Tree planting on city property shall be in accordance with the City of Ottawa's Tree Planting Specification; and include watering and

warranty as described in the specification (can be provided by Forestry Services).

- Plant native trees whenever possible
- No root barriers, dead-man anchor systems, or planters are permitted.
- No tree stakes unless necessary (and only 1 on the prevailing winds side of the tree)

**Hard surface planting**

- Curb style planter is highly recommended
- No grates are to be used and if guards are required, City of Ottawa standard (which can be provided) shall be used.
- Trees are to be planted at grade

**Soil Volume**

- Please note that the City is now requiring that minimum soil volumes be met/exceeded for all new plantings
- Please document on the Landscape Plan that adequate soil volumes can be met:

Tree Type/Size	Single Tree Soil Volume (m3)	Multiple Tree Soil Volume (m3/tree)
Ornamental	15	9
Columnar	15	9
Small	20	12
Medium	25	15
Large	30	18
Conifer	25	15

Please note that these soil volumes are not applicable in cases with Sensitive Marine Clay.

**Sensitive Marine Clay**

- Please follow the City’s 2017 Tree Planting in Sensitive Marine Clay guidelines

**Tree Canopy Cover**

- The landscape plan shall show how the proposed tree planting will replace and increase canopy cover on the site over time, to support the City’s 40% urban forest canopy cover target.
- At a site level, efforts shall be made to provide as much canopy cover as possible, through tree planting and tree retention, with an aim of 40% canopy cover at 40 years, as appropriate.

- Indicate on the plan the projected future canopy cover at 40 years for the site.

**Mark Richardson R.P.F.** ☎ 613.580.2424 ext./poste 23839

### Parkland Dedication

1. The amount of parkland dedication that is required is to be calculated as per the City of Ottawa Parkland Dedication By-law No.2009-95 (or equivalent).

Section 13 (1) of the By-law states that *“The conveyance of land for park purposes or the payment of money in-lieu of accepting the conveyance is not required for development, redevelopment, subdivisions or consents, where it is known, or can be demonstrated that the required parkland conveyance or money in-lieu thereof has been previously satisfied in accordance with the Planning Act”*

If parkland dedication for the parcel has been satisfied previously, please provide Parks and Facilities Planning with the supporting documentation.

Otherwise, the owner will be responsible for providing parkland dedication.

Parkland dedication will be a condition of site plan approval, the owner will be responsible in providing cash-in-lieu of parkland.

2. The value of the land will be determined by the City's Realty Services Branch. The owner is responsible for any appraisal costs incurred by the City.
3. Please provide the City with a surveyor's area certificate/memo which specifies the exact gross land area of the property parcel being developed.
4. Please note that the park comments are preliminary and will be finalized (and subject to change) upon receipt of the requested supporting documentation

### Urban Design

1. A design brief that follows the provided Terms of Reference is required upon submission of the application.
2. Support the orientation of the building to front onto Navan Road and the location of the vehicular access from Falsetto Street. This rear vehicular access helps to minimize the impact of driveways and parking on the pedestrian environment and avoids rear lotting.
3. Ensure adequate screening of the parking lot and parking garage entrance from the western lot line, which abuts a public road as well as from the southern lot line, which abuts the rear and interior yards of residential dwellings.
4. Consider opportunities for architectural treatments, or even massing adjustments, to respond to the two corner conditions at the intersection of Navan Rd and Page Rd as well as at the intersection of Navan Rd and Falsetto St. Strong corner treatments create a focal point and address both street fronts.
5. As the elevations and renderings develop, ensure the principal entries are clearly identifiable, visible from the street. Trees can be used to frame these entrances. Staff support the direct pathways leading to Navan Road.

6. Explore providing a direct pathway to the development from Page Rd as well. Consider the proximity and location of the bus stop and the Canada Post mailboxes on Page Rd when designing pathways onsite. Staff support the pedestrian pathway leading to Falsetto St.
7. As a long six-storey building, explore opportunities to break up the massing.
  - a. To address the horizontal length of the building mass along Navan Rd, create variation at-grade. The continuous massing can be broken down to smaller parts using vertical breaks, different materials or colours, architectural elements such as bays and porches. It appears from the concept that there are multiple at-grade entrances to individual units; this is supported and encouraged to be retained.
  - b. To address the 6-storey height of the building, explore a stepbacks in massing and architectural façade treatments to create a datum line. Careful articulation of the lower levels is necessary as these have the greatest impact on the pedestrian environment. The mid-rise building should have a base that relates to the pedestrian realm, a middle portion that relates to the future streetwall/adjacent buildings along Navan Rd, and a top that incorporates stepbacks. Be aware of required setbacks from the Hydro wires on Navan Rd.
8. Consider opportunities to retain trees and incorporate new trees and soft landscaping
  - a. Note that Section 5.1 of the *East Urban Community CDP Phase 1* has guidelines to establish minimum planting requirements. It states “*Plant...one tree for every two...apartment units*”. It also states “*where there is insufficient room on a site plan application...to plant the required number of trees, the ‘owed’ trees will contribute to a ‘tree bank’ and will be planted within the community*”.
  - b. It appears from aerial images and streetview that there is substantial existing landscaping at the rear of the residential development which fronts on to Renaud Rd and backs onto this property. Be cognizant of these adjacently owned trees and take measures to protect them through the excavation and construction process.
  - c. Clarify the setbacks of the trees from the foundation of the building and the extent of the underground parking garage.
  - d. Try to retain as many trees as possible and provide landscape treatment that contributes to all lot lines abutting public Rights-Of-Way (Navan Rd, Page Rd, and Falsetto St) and provides visual buffers to parking from interior lot lines.
  - e. The Geotechnical report should address the plasticity of the soil. A Tree Conservation Report and Landscape Plan should be provided.
9. All other provisions of the *East Urban Community CDP Phase 1*, particularly Section 5.1 and 5.2, and *Transit-Oriented Development Guidelines* (the property is within 600m of the Chapel Hill transit station) for should be complied with where possible.

If you have any comments or questions, please do not hesitate to reach out to Ann O'Connor

Attachments:

1. Required Plans and Report Submission
2. Design Brief
3. High Performance Development Standards – Pre-application Consultation Handout
4. City of Ottawa Accessible Design Standards (ADS) Site Plan Checklist
5. Backgrounder on the minor variance process
6. Email Correspondence between Engineers
7. Email from Will Curry dated May 19, 2022

**From:** [Curry, William](#)  
**To:** [Eric Forhan](#)  
**Cc:** [Ramirez, Lucy](#); [Karla Ferrey](#); [Trevor Dickie](#); [Tim F. Chadder](#); [Marcus Joseph](#); [Guy Forget](#)  
**Subject:** Re: 31856-000.0 - 3080 Navan Road - Pre-consultation follow-up  
**Date:** May 13, 2022 11:00:37 AM  
**Attachments:** [0.png](#)

---

**below**

---

**From:** Eric Forhan <eforhan@jlrichards.ca>  
**Sent:** Friday, May 13, 2022 10:43 AM  
**To:** Curry, William <William.Curry@ottawa.ca>  
**Cc:** Ramirez, Lucy <lucy.ramirez@ottawa.ca>; Karla Ferrey <kferrey@jlrichards.ca>; Trevor Dickie <trevor.dickie@broadstreet.ca>; Tim F. Chadder <tchadder@jlrichards.ca>; Marcus Joseph <marcus.joseph@seymourpacific.ca>; Guy Forget <gforget@jlrichards.ca>  
**Subject:** 31856-000.0 - 3080 Navan Road - Pre-consultation follow-up

**CAUTION: This email originated from an External Sender. Please do not click links or open attachments unless you recognize the source.**

**ATTENTION : Ce courriel provient d'un expéditeur externe. Ne cliquez sur aucun lien et n'ouvrez pas de pièce jointe, excepté si vous connaissez l'expéditeur.**

Hello William,

Thank you for taking time out of your day to attend our pre-consultation meeting for 3080 Navan Road.

Here are the comments/ questions related to (Engineering) Design Confirmation that Trevor and I briefly mentioned yesterday. We hope these will help with the preparation of your pre-con comments.

If you have any questions, comments or concerns, please contact Karla Ferrey (cc'd) directly.

### **Storm/SWM**

1. The Subject Lands are currently tributary to and serviced by the East Urban Community Stormwater Management Pond 3 (Pond 3), which provides quantity, quality and erosion control service to an approximate total drainage area of 200 ha (2005 ISSU) within the Mud Creek Subwatershed. **In accordance with the ISSU, the Caivan Functional Servicing Report (April 2021-3<sup>rd</sup> submission) and the Caivan – Rhythm Development- Design Report (May 2022) the Maximum allowable flow rate from this block is 85L/s/ha. Therefore the site will have a Maximum Flow Rate of 57 L/s (0.67ha \*85L/s/ha = 57L/s), please confirm this allowance. No, that is the target RR, 85 L/s/ha. If you have uncontrolled areas, they are subtracted from the target RR and that is the New Permitted Release Rate and Volume storage is based upon that permitted RR.**
2. Block to provide 100-year onsite capture. Onsite storage to be determine at detailed design and will be combination of possible roof top storage, subsurface storage and parking /landscaped area surface storage. **Fine**
3. As noted in the Caivan -Rhythm Development - April 2021 FSR, the subject lands are not

suitable for application of LID measures. Urbantech is proposing LID everywhere with the Caivan Subdivision. It is all LID

LID implementation on the Subject Lands is severely constrained due to underlying soil conditions and shallow groundwater depth. 3-4 metres deep as per the geotech  
Therefore, given the limited potential benefit of LID implementation below the escarpment in general, and the poor suitability of the Subject Lands, LID measures are not recommended for the Proposed Development. Whatever, if you don't want them then don't provide them. You're the one who must provide storage, so it is your call. You have no soft area on site to provide a small Bio-swale and intend to provide all storage in the parking area.....100% fine.

**Please confirm LIDs will not be required for this site.**

4. According to the Pond 3 design details (Stantec, 2005), the required permanent pool of 10,887m<sup>3</sup> was based on assuming 55% imperviousness for the subject lands and the provided permanent pool was 18,986m

There is more than sufficient quality control volume in the pond to manage the drainage from the subject lands. Therefore, no additional measures are required. Fine, but Quality requirements are provided by the RVCA and not the City. They will comment with the City circulation.

**Please confirm no additional measures are required.**

5. Similarly, Erosion control is provided by Pond 3, therefore no additional measures are required for this site. RVCA to confirm with the City circulation

**Please confirm no additional measures are required.**

#### **ECA Requirement**

6. Given that this will most likely be one property owned by one owner (i.e., one corporation) then no SAN or ST ECA is required for this site plan. Correct, if it does not share/service stormwater over multiple parcels. Does not service more than one parcel.

**Please confirm this is the City's assumption as well.**

#### **Sanitary**

7. We understand from the sanitary sewer design sheets presented in the Caivan – Rhythm Development- Design Report (May 2022) the allowable wastewater flow for this site is:  
From Sanitary Design Sheet: Area=0.67, units assumed 150 units, Density 1.9 ppu, 285 population, infiltration 0.2 L/s, peaking factor 3.47, Res Flow 3.2L/s = TOTAL FLOW 3.4 L/s

**Please confirm this is the allowable flow rate for the site, please note it is currently proposed to construct a building with 107 units. I will confirm you have capacity.**

#### **Water,**

Most likely there will be a requirement by the City to provide dual connections since we exceed 50 units and that the average day demand will exceed 50 m<sup>3</sup>. Rather than to provide dual

connection side by side with an isolation valve, the system would be more robust if the two connections were independent is there an opportunity to ask the proponent (Caivan Development) to add another connection along the site frontage.

The site currently only has one stub to service this site, can another stub be provided for this site plan development **I will ask them to provide another beside the existing (side by side)**

**I will provide their latest plans. Should arrive today**

**Eric Forhan, MScPI**  
Planner

J.L. Richards & Associates Limited  
700 - 1565 Carling Avenue, Ottawa, ON K1Z 8R1  
Direct: 343-804-5364





**Appendix B**  
**Water Servicing**

**RHYTHM APARTMENTS**  
**Water Demand**

Table 1 Water Demand									
Occupancy	Unit Type					Total Population	Total Demand (L/s)		
	Office Area (Area m <sup>2</sup> )	1 Bed Apartment	2 Bed Apartment	3 Bed Apartment	Total Units		Avg Day	Max. Daily	Peak Hour
<b>Rhythm Apartments</b>									
Residential		32	63	24	119	252	0.82	2.04	4.49
Commercial	100						0.01	0.01	0.02
<b>Total</b>							<b>0.83</b>	<b>2.06</b>	<b>4.51</b>

**Design Parameters:**

- 1 Bed Apartment                               **1.4 persons/unit**
- 2 Bed Apartment                               **2.1 persons/unit**
- 3 Bed Apartment                               **3.1 persons/unit**

City of Ottawa Water Distribution Guidelines

- Average Domestic Flow                               280     L/c/day

Daily Demands from OBC Table 8.2.1.3

- Commerical Space                               75     L/9.3m<sup>2</sup>/day

Residential Peaking Factors City of Ottawa Water Distrubution Guidelines:

Conditions	Peaking Factor	Units
Maximum Day	2.5     x avg day	L/c/day
Peak Hour	2.2     x max day	L/c/day

Commercial Peaking Factors City of Ottawa Water Distribution Guidelines

Conditions	Peaking Factor	Units
Maximum Day	1.5     x avg day	L/c/day
Peak Hour	1.8     x max day	L/c/day

**From:** Patrick Darcey <patrick.darcey@seymourpacific.ca>

**Sent:** Thursday, December 15, 2022 2:27 PM

**To:** Anthony Mestwarp <a.mestwarp@novatech-eng.com>

**Cc:** Greg MacDonald <g.Macdonald@novatech-eng.com>; Trevor Dickie <trevor.dickie@broadstreet.ca>; Rachel Ricard <rachel.ricard@seymourpacific.ca>

**Subject:** RE: Set Backs

Hi Anthony,

There is no plan to have tenants access the roof at this time.

Amenity area.

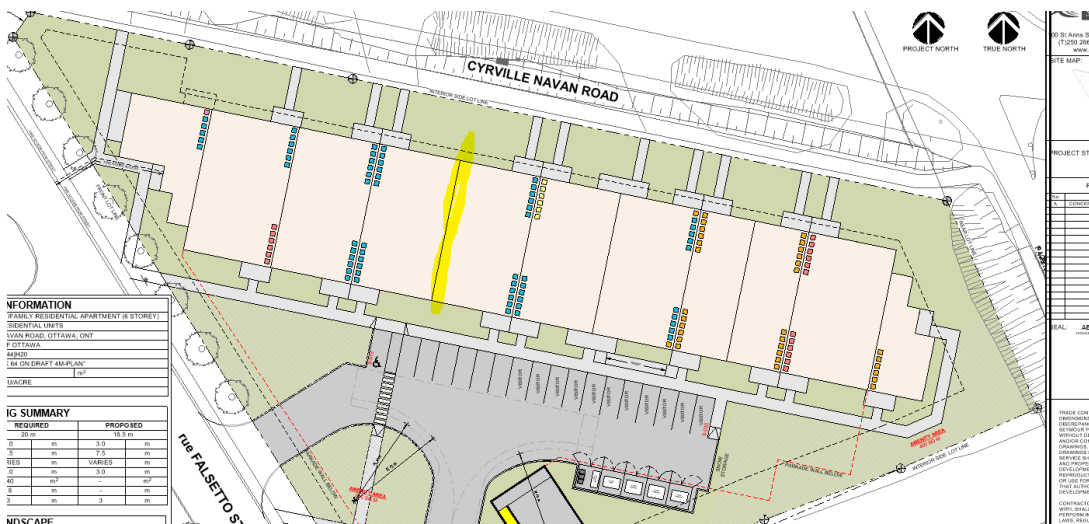
This will be confirmed once BSP reviews the site plan but would assume some hardscape.

**Sprinkler System**

This is a fully supervised sprinkler system which is monitored by a third party. This is typical of all our Apartment projects.

Firewall will be 2 hours separation.

Located here:



Thanks,  
Patrick Darcey  
*BIM Specialist*

BROADSTREET PROPERTIES LTD.  
SEYMOUR PACIFIC DEVELOPMENTS LTD.  
100 St. Ann's Rd, Campbell River, BC V9W 4C4  
T. 250.850.3244 | C. | F. 250.286.8047  
W. [www.broadstreet.ca](http://www.broadstreet.ca) | [www.seymourpacific.ca](http://www.seymourpacific.ca)

**From:** Anthony Mestwarp <[a.mestwarp@novatech-eng.com](mailto:a.mestwarp@novatech-eng.com)>

**Sent:** December 15, 2022 10:43 AM

**To:** Patrick Darcey <[patrick.darcey@seymourpacific.ca](mailto:patrick.darcey@seymourpacific.ca)>

**Cc:** Greg MacDonald <[g.Macdonald@novatech-eng.com](mailto:g.Macdonald@novatech-eng.com)>; Trevor Dickie <[trevor.dickie@broadstreet.ca](mailto:trevor.dickie@broadstreet.ca)>; Rachel Ricard <[rachel.ricard@seymourpacific.ca](mailto:rachel.ricard@seymourpacific.ca)>

**Subject:** RE: Set Backs

**CAUTION: External Email**

Hi Patrick,

Thanks for the plans.

Will there be any restrictions preventing rooftop storage on this site that currently are not detailed on the roof plans?  
Eg. Terraces that are accessible by the tenants?

Also for the amenity areas will they be mostly landscape, or should I assume some hardscaping will be placed in those areas when calculating the stormwater run-off.

A fully supervised sprinkler system is defined as follows:

**Fully Supervised System (10%)**

To qualify to apply an additional 10% reduction, an automatic sprinkler system should be fully supervised. The purpose of the supervisory signal is to ensure that malfunctions of the automatic sprinkler system will be discovered and corrected promptly, while the water flow alarm serves to notify emergency services of the fire as soon as the automatic sprinkler system activates.

- a distinctive supervisory signal to indicate conditions that could impair the satisfactory operation of the sprinkler system (a fault alarm), which is to sound and be displayed, either at a location within the building that is constantly attended by qualified personnel (such as a security room), or at an approved remotely located receiving facility (such as a monitoring facility of the sprinkler system manufacturer); and
- a water flow alarm to indicate that the sprinkler system has been activated, which is to be transmitted to an approved, proprietary alarm-receiving facility, a remote station, a central station or the fire department.

Can you also confirm the location and rating of the firewall.

Sorry for all of the questions, but once I have the above information I should be able to determine the required site fire flows, and approximate cistern size requirements.

Thanks,

**Anthony Mestwarp, P.Eng.**, Project Engineer | Land Development Engineering

**NOVATECH** Engineers, Planners & Landscape Architects

240 Michael Cowpland Drive, Suite 200, Ottawa, ON, K2M 1P6 | Tel: 613.254.9643 Ext. 216 | Fax: 613.254.5867

The information contained in this email message is confidential and is for exclusive use of the addressee.

**From:** Patrick Darcey <[patrick.darcey@seymourpacific.ca](mailto:patrick.darcey@seymourpacific.ca)>

**Sent:** Thursday, December 15, 2022 11:57 AM

**To:** Anthony Mestwarp <[a.mestwarp@novatech-eng.com](mailto:a.mestwarp@novatech-eng.com)>

**Cc:** Greg MacDonald <[g.Macdonald@novatech-eng.com](mailto:g.Macdonald@novatech-eng.com)>; Trevor Dickie <[trevor.dickie@broadstreet.ca](mailto:trevor.dickie@broadstreet.ca)>; Rachel Ricard <[rachel.ricard@seymourpacific.ca](mailto:rachel.ricard@seymourpacific.ca)>

**Subject:** RE: Set Backs

See attached for parkade and roof plan.

I have also attached the latest site plan with the entryway that was proposed. Small tweaks have occurred and still need final approval on the garbage layout.

Please note that there will be a small revision to the roof plan in regard to the roof over the decks.

- The typical floor areas.
  - Level 1
    - 1892.618m<sup>2</sup>
    - Left Side 530.286 m<sup>2</sup>
    - Right Side 1362.32 m<sup>2</sup>
    - This is split into two areas because of the fire wall.
  - Level 2 - 6
    - This area increase because of bump outs.
    - 1919.149
    - Left Side 737.746 m<sup>2</sup>
    - Right Side 1181.403 m<sup>2</sup>
    -
- The type of Building Construction
  - Concrete construction for parkade and wood framing for the level 1 – 6.
- Confirm if the building is to be sprinklered
  - Yes sprinklered
- Confirm if the sprinkler system is fully supervised
  - Can you please clarify.
    - This will be on a fire alarm system.
- Area of commercial development
  - This will be the site rental office

I have some work to revised the elevation / floor plan with removal of a closet on the decks but will get those revised shortly.

Thanks,

Patrick Darcey  
*BIM Specialist*

BROADSTREET PROPERTIES LTD.

SEYMOUR PACIFIC DEVELOPMENTS LTD.

100 St. Ann's Rd, Campbell River, BC V9W 4C4

**T.** 250.850.3244 | **C.** | **F.** 250.286.8047

**W.** [www.broadstreet.ca](http://www.broadstreet.ca) | [www.seymourpacific.ca](http://www.seymourpacific.ca)

**From:** Anthony Mestwarp <[a.mestwarp@novatech-eng.com](mailto:a.mestwarp@novatech-eng.com)>

**Sent:** December 15, 2022 8:29 AM

**To:** Patrick Darcey <[patrick.darcey@seymourpacific.ca](mailto:patrick.darcey@seymourpacific.ca)>

**Cc:** Greg MacDonald <[g.Macdonald@novatech-eng.com](mailto:g.Macdonald@novatech-eng.com)>; Trevor Dickie <[trevor.dickie@broadstreet.ca](mailto:trevor.dickie@broadstreet.ca)>; Rachel Ricard <[rachel.ricard@seymourpacific.ca](mailto:rachel.ricard@seymourpacific.ca)>

**Subject:** RE: Set Backs

**CAUTION: External Email**

Hi Patrick,

Any progress on the plans? For the noise study we will require the elevation views, and typical floor plans once available.

Are you also able to provide an email confirming the following:

- The typical floor areas.
- The type of Building Construction
- Confirm if the building is to be sprinklered
- Confirm if the sprinkler system is fully supervised
- Area of commercial development

Thanks,

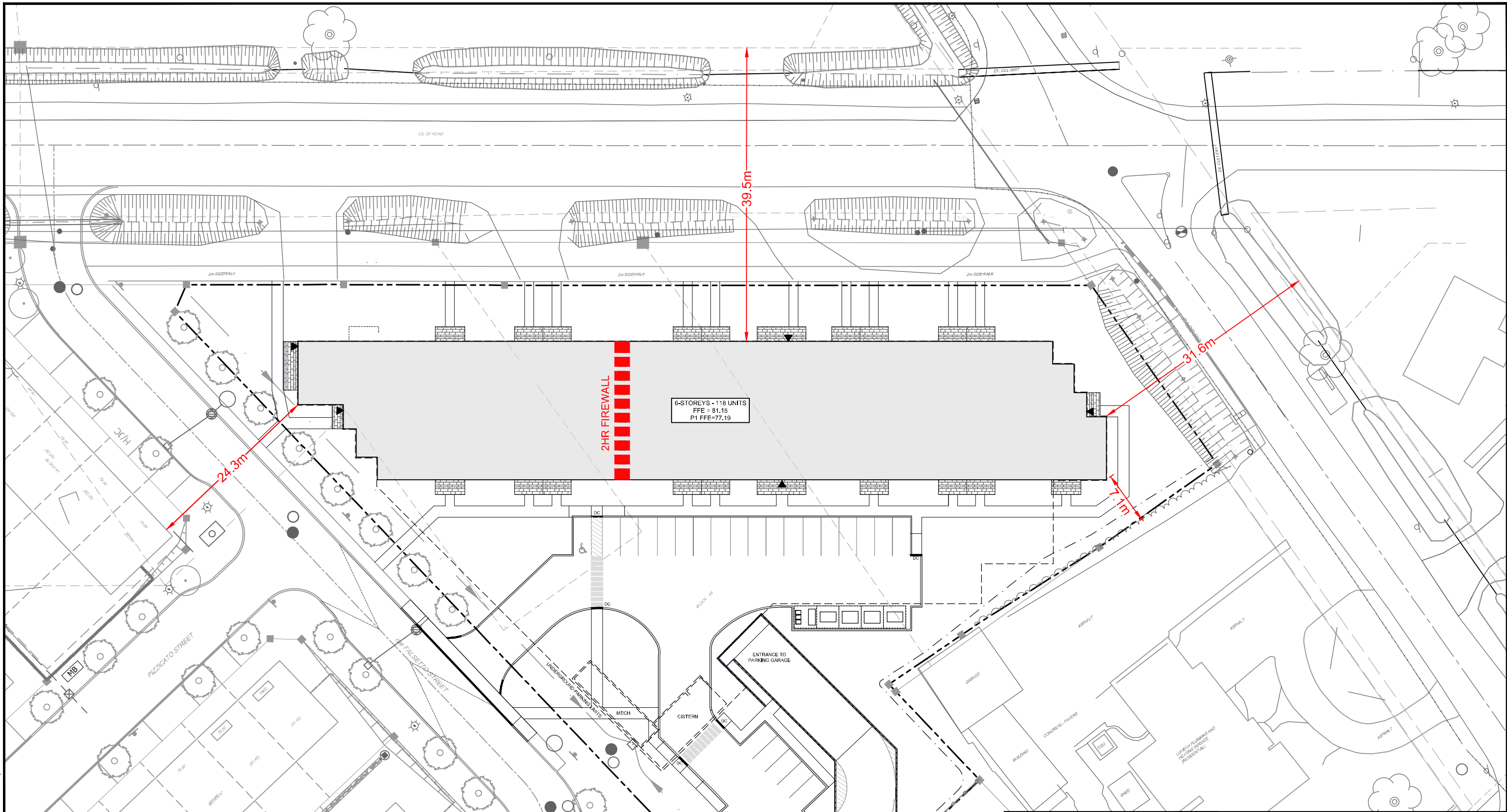
**Anthony Mestwarp, P.Eng.**, Project Engineer | Land Development Engineering

**NOVATECH** Engineers, Planners & Landscape Architects




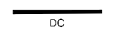

240 Michael Cowpland Drive, Suite 200, Ottawa, ON, K2M 1P6 | Tel: 613.254.9643 Ext. 216 | Fax: 613.254.5867

The information contained in this email message is confidential and is for exclusive use of the addressee.

M:\2022\122180\CAD\Civil\Figures\FUS\122180-FUS Sep.dwg, SEP, Jan 19, 2023 - 4:18pm, amestwarp



### LEGEND

-  PROPERTY LINE
-  PROPOSED TACTILE INDICATOR
-  PROPOSED ENTRANCE
-  PROPOSED DEPRESSED CURB
-  2HR FIREWALL



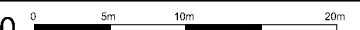
**NOVATECH**

Engineers, Planners & Landscape Architects  
 Suite 200, 240 Michael Cowpland Drive  
 Ottawa, Ontario, Canada K2M 1P6

Telephone (613) 254-9643  
 Facsimile (613) 254-5867  
 Website [www.novatech-eng.com](http://www.novatech-eng.com)

CITY OF OTTAWA  
 RHYTHM APARTMENTS

### FUS SEPARATION

SCALE 1 : 500 

DATE JAN 2023 JOB 122180 FIGURE FUS

# FUS - Fire Flow Calculations

As per 2020 Fire Underwriter's Survey Guidelines



Engineers, Planners & Landscape Architects

Novatech Project #: 122180  
 Project Name: Rythem Apartments  
 Date: 1/19/2023  
 Input By: Curtis Ferguson, E.I.T.  
 Reviewed By: Anthony Mestwarp, P.Eng

Legend

Input by User

No Information or Input Required

Building Description: 6 Storey Multifamily Residential Apartment (EAST)  
 Type V - Wood frame

Step	Input		Value Used	Total Fire Flow (L/min)		
<b>Base Fire Flow</b>						
1	<b>Construction Material</b>		<b>Multiplier</b>	1.5		
	<b>Coefficient related to type of construction C</b>	Type V - Wood frame	Yes		1.5	
		Type IV - Mass Timber			Varies	
		Type III - Ordinary construction			1	
		Type II - Non-combustible construction			0.8	
Type I - Fire resistive construction (2 hrs)			0.6			
2	<b>Floor Area</b>			28,000		
	<b>A</b>	Building Footprint (m <sup>2</sup> )	1164		6,984	
		Number of Floors/Storeys	6			
		Area of structure considered (m <sup>2</sup> )				
	<b>F</b>	<b>Base fire flow without reductions</b>				
$F = 220 C (A)^{0.5}$						
<b>Reductions or Surcharges</b>						
3	<b>Occupancy hazard reduction or surcharge</b>		<b>FUS Table 3</b>	<b>Reduction/Surcharge</b>		
	<b>(1)</b>	Non-combustible		-25%	-15%	
		Limited combustible	Yes	-15%		
		Combustible		0%		
		Free burning		15%		
Rapid burning			25%			
4	<b>Sprinkler Reduction</b>		<b>FUS Table 4</b>	<b>Reduction</b>		
	<b>(2)</b>	Adequately Designed System (NFPA 13)	Yes	-30%	-30%	
		Standard Water Supply	Yes	-10%	-10%	
		Fully Supervised System	Yes	-10%	-10%	
		<b>Cumulative Sub-Total</b>			<b>-50%</b>	
<b>Area of Sprinklered Coverage (m<sup>2</sup>)</b>		5587.2	80%			
		<b>Cumulative Total</b>	<b>-40%</b>			
5	<b>Exposure Surcharge</b>		<b>FUS Table 5</b>	<b>Surcharge</b>		
	<b>(3)</b>	North Side	>30m	0%	15%	
		East Side	>30m	0%		
		South Side	10.1 - 20 m	15%		
		West Side	Firewall-2hr	0%		
<b>Cumulative Total</b>			<b>15%</b>			
<b>Results</b>						
6	<b>(1) + (2) + (3)</b>	<b>Total Required Fire Flow, rounded to nearest 1000L/min</b>		<b>L/min</b>	<b>18,000</b>	
		(2,000 L/min < Fire Flow < 45,000 L/min)		or	<b>L/s</b>	<b>300</b>
				or	<b>USGPM</b>	<b>4,756</b>



# FUS - Fire Flow Calculations

As per 2020 Fire Underwriter's Survey Guidelines



Engineers, Planners & Landscape Architects

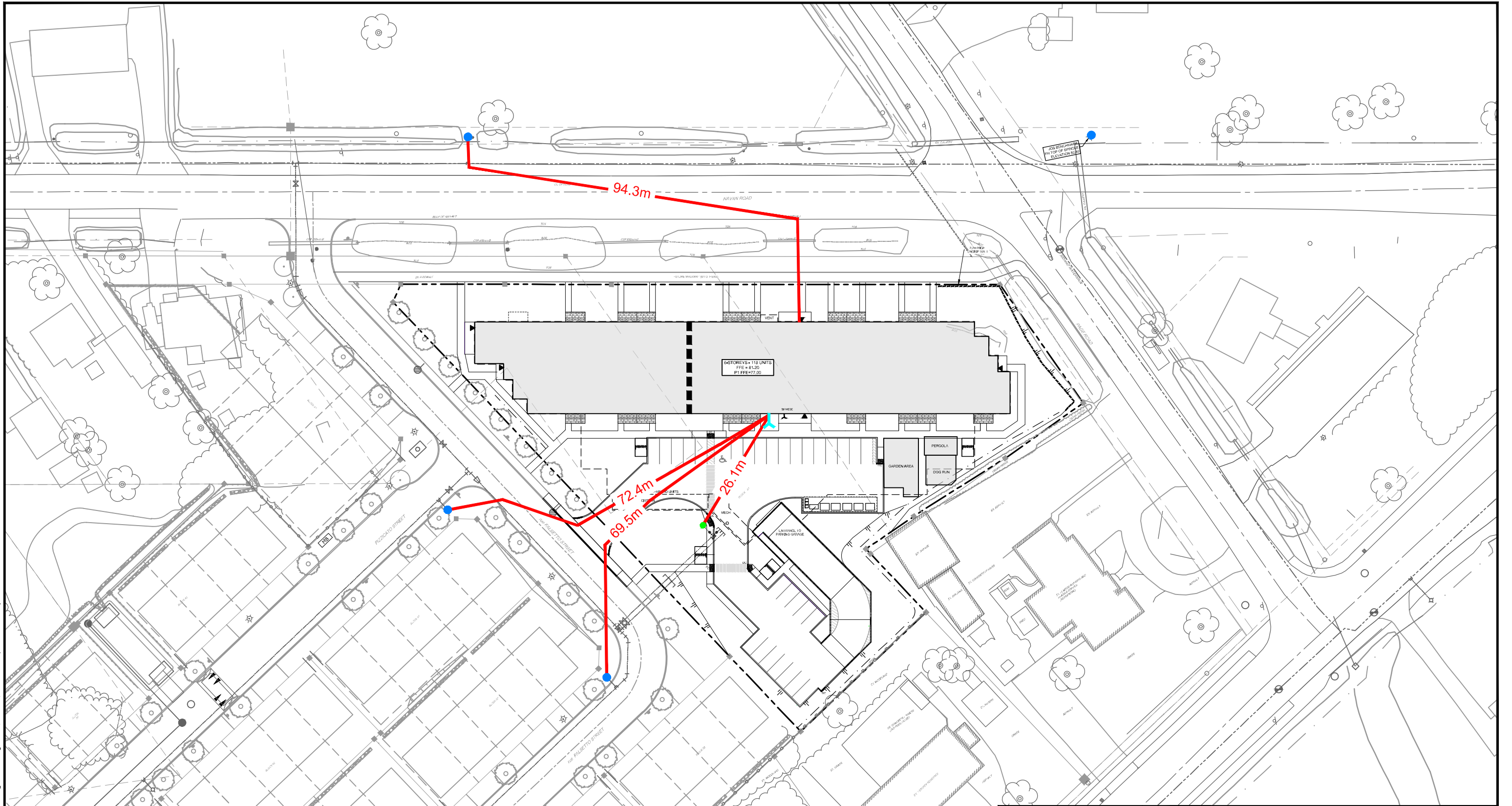
**Novatech Project #:** 122180  
**Project Name:** Rythem Apartments  
**Date:** 1/19/2023  
**Input By:** Curtis Ferguson, E.I.T.  
**Reviewed By:** Anthony Mestwarp, P.Eng

Legend	Input by User
	No Information or Input Required

**Building Description:** 6 Storey Multifamily Residential Apartment (WEST)  
**Type V - Wood frame**

Step	Input		Value Used	Total Fire Flow (L/min)		
<b>Base Fire Flow</b>						
1	<b>Construction Material</b>		<b>Multiplier</b>	1.5		
	<b>Coefficient related to type of construction</b> <b>C</b>	Type V - Wood frame	Yes		1.5	
		Type IV - Mass Timber			Varies	
		Type III - Ordinary construction			1	
		Type II - Non-combustible construction			0.8	
Type I - Fire resistive construction (2 hrs)			0.6			
2	<b>Floor Area</b>			22,000		
	<b>A</b>	Building Footprint (m <sup>2</sup> )	738		4,428	
		Number of Floors/Storeys	6			
		Area of structure considered (m <sup>2</sup> )				
	<b>F</b>	<b>Base fire flow without reductions</b>				
<b>F = 220 C (A)<sup>0.5</sup></b>						
<b>Reductions or Surcharges</b>						
3	<b>Occupancy hazard reduction or surcharge</b>		<b>FUS Table 3</b>	<b>Reduction/Surcharge</b>		
	<b>(1)</b>	Non-combustible		-25%	-15%	
		Limited combustible	Yes	-15%		
		Combustible		0%		
		Free burning		15%		
Rapid burning			25%			
4	<b>Sprinkler Reduction</b>		<b>FUS Table 4</b>	<b>Reduction</b>		
	<b>(2)</b>	Adequately Designed System (NFPA 13)	Yes	-30%	-30%	
		Standard Water Supply	Yes	-10%	-10%	
		Fully Supervised System	Yes	-10%	-10%	
		<b>Cumulative Sub-Total</b>			<b>-50%</b>	
<b>Area of Sprinklered Coverage (m<sup>2</sup>)</b>		<b>3542.4</b>	80%			
		<b>Cumulative Total</b>	<b>-40%</b>			
5	<b>Exposure Surcharge</b>		<b>FUS Table 5</b>	<b>Surcharge</b>		
	<b>(3)</b>	North Side	>30m		0%	
		East Side	Firewall-2hr		0%	
		South Side	20.1 - 30 m		10%	
		West Side	20.1 - 30 m		10%	
		<b>Cumulative Total</b>	<b>20%</b>			
<b>Results</b>						
6	<b>(1) + (2) + (3)</b>	<b>Total Required Fire Flow, rounded to nearest 1000L/min</b>		<b>L/min</b>	<b>15,000</b>	
		(2,000 L/min < Fire Flow < 45,000 L/min)		or	<b>L/s</b>	<b>250</b>
				or	<b>USGPM</b>	<b>3,963</b>

M:\2022\122180\CAD\Civil\Figures\FUS122180-Coverage Plan.dwg, COV, Jan 19, 2023 - 4:35pm, amestwarp



**LEGEND**

- PROPERTY LINE
- PROPOSED SIAMESE CONNECTION
- EXISTING CLASS AA HYDRANT
- PROPOSED HYDRANT
- DISTANCE FROM HYDRANT TO SIAMESE CONNECTION/ BUILDING ENTRANCE



**NOVATECH**  
 Engineers, Planners & Landscape Architects  
 Suite 200, 240 Michael Cowpland Drive  
 Ottawa, Ontario, Canada K2M 1P6

Telephone (613) 254-9643  
 Facsimile (613) 254-5867  
 Website www.novatech-eng.com

**CITY OF OTTAWA  
 RHYTHM APARTMENTS**

**COVERAGE PLAN**

SCALE 1 : 750

DATE	JOB	FIGURE
MARCH 2023	122180	COV





**From:** Rasool, Rubina <Rubina.Rasool@ottawa.ca>  
**Sent:** Wednesday, January 18, 2023 9:08 AM  
**To:** Anthony Mestwarp <a.mestwarp@novatech-eng.com>  
**Cc:** Curtis Ferguson <c.ferguson@novatech-eng.com>; Greg MacDonald <g.Macdonald@novatech-eng.com>  
**Subject:** RE: 3080 Navan Road - Water Boundary Conditions

Hi Anthony,

Please find attached the WBC and IPU comments related to a looped connection.

“A second watermain feed off Renaud Road is required to provide developments north of Renaud and South of Navan with a reliable water supply (see below). The second feed must be built as part of this application. Furthermore, I have attached an update to the FUS guidelines. I would ask Novatech to review their calculations with the 2020 FUS update in order to reduce their required fire flow of 400 l/s.”



**Figure 1 – Proposed Watermain Sizing & Layout**

**Rubina**

-----  
**Rubina Rasool**  
Project Manager  
Planning, Infrastructure and Economic Development Department  
Development Review – East Branch  
City of Ottawa  
110 Laurier Avenue West Ottawa, ON K1P 1J1  
[rubina.rasool@ottawa.ca](mailto:rubina.rasool@ottawa.ca)

**From:** Anthony Mestwarp <[a.mestwarp@novatech-eng.com](mailto:a.mestwarp@novatech-eng.com)>  
**Sent:** January 9, 2023 11:11  
**To:** Surprenant, Eric <[Eric.Surprenant@ottawa.ca](mailto:Eric.Surprenant@ottawa.ca)>  
**Cc:** Curtis Ferguson <[c.ferguson@novatech-eng.com](mailto:c.ferguson@novatech-eng.com)>; Greg MacDonald <[g.Macdonald@novatech-eng.com](mailto:g.Macdonald@novatech-eng.com)>  
**Subject:** FW: 3080 Navan Road - Water Boundary Conditions

**CAUTION: This email originated from an External Sender. Please do not click links or open attachments unless you recognize the source.**

**ATTENTION : Ce courriel provient d'un expéditeur externe. Ne cliquez sur aucun lien et n'ouvrez pas de pièce jointe, excepté si vous connaissez l'expéditeur.**

I tried emailing William Curry regrading Boundary conditions for the site at 3080 Navan Road , but I received a bounce back. Can you please direct me to the appropriate contact for the East end?

Thanks,

**Anthony Mestwarp, P.Eng.**, Project Engineer | Land Development Engineering

**NOVATECH** Engineers, Planners & Landscape Architects

240 Michael Cowpland Drive, Suite 200, Ottawa, ON, K2M 1P6 | Tel: 613.254.9643 Ext. 216 | Fax: 613.254.5867

The information contained in this email message is confidential and is for exclusive use of the addressee.

**From:** Anthony Mestwarp  
**Sent:** Monday, January 9, 2023 10:26 AM  
**To:** [william.curry@ottawa.ca](mailto:william.curry@ottawa.ca)  
**Cc:** Curtis Ferguson <[c.ferguson@novatech-eng.com](mailto:c.ferguson@novatech-eng.com)>; Greg MacDonald <[g.Macdonald@novatech-eng.com](mailto:g.Macdonald@novatech-eng.com)>  
**Subject:** 3080 Navan Road - Water Boundary Conditions

Hi William,

Please find attached the supporting documents for the boundary conditions request for 3080 Navan.

The proposed site will have a total of 118 units (31 1-bed, 63 2-bed, & 24 3-Bed), and 100m<sup>2</sup> of commercial area.

Total demands and fire flows are summarized below;

- Average Daily Demand: 0.82 L/s
- Max Daily Demand: 2.05 L/s
- Peak Hour Demand: 4.49 L/s
- Fire Flow (FUS): 367 L/s

It is proposed to service the development from the stubs provided from the neighboring subdivision.

Please let us know if you have any questions.

Regards,

**Anthony Mestwarp, P.Eng.**, Project Engineer | Land Development Engineering

**NOVATECH** Engineers, Planners & Landscape Architects

240 Michael Cowpland Drive, Suite 200, Ottawa, ON, K2M 1P6 | Tel: 613.254.9643 Ext. 216 | Fax: 613.254.5867

The information contained in this email message is confidential and is for exclusive use of the addressee.

This e-mail originates from the City of Ottawa e-mail system. Any distribution, use or copying of this e-mail or the information it contains by other than the intended recipient(s) is unauthorized. Thank you.

Le présent courriel a été expédié par le système de courriels de la Ville d'Ottawa. Toute distribution, utilisation ou reproduction du courriel ou des renseignements qui s'y trouvent par une personne autre que son destinataire prévu est interdite. Je vous remercie de votre collaboration.





## **Notes**

- Second feed off Renauld Road is required to avoid the creation of a vulnerable service area.

*The boundary condition information is based on current operation of the city water distribution system. The computer model simulation is based on the best information available at the time. The operation of the water distribution system can change on a regular basis, resulting in a variation in boundary conditions. The physical properties of watermains deteriorate over time, as such must be assumed in the absence of actual field test data. The variation in physical watermain properties can therefore alter the results of the computer model simulation. Fire Flow analysis is a reflection of available flow in the watermain; there may be additional restrictions that occur between the watermain and the hydrant that the model cannot take into account.*

**CALCULATED WATER DEMANDS:**

**Water Demands**

Average Day (Maximum HGL)= 0.83 L/s  
Maximum Day = 2.06 L/s  
Peak Hour (Minimum HGL) = 4.51 L/s  
Fire Flow (FUS) = 300.00 L/s

**City of Ottawa Boundary Conditions:**

Average Day (Maximum HGL)= 130.7 m  
Peak Hour (Minimum HGL) = 126.8 m  
Max Day + Fire = 112.4 m

**Watermain Analysis**

Finished Floor Elevation = 81.20 m

High Pressure Test = Max. HGL - Finished Floor Elevation x 1.42197 PSI/m < 80 PSI

**High Pressure = 70.4 PSI**

Low Pressure Test = Min. HGL - Finished Floor Elevation x 1.42197 PSI/m > 40 PSI

**Low Pressure = 64.8 PSI**

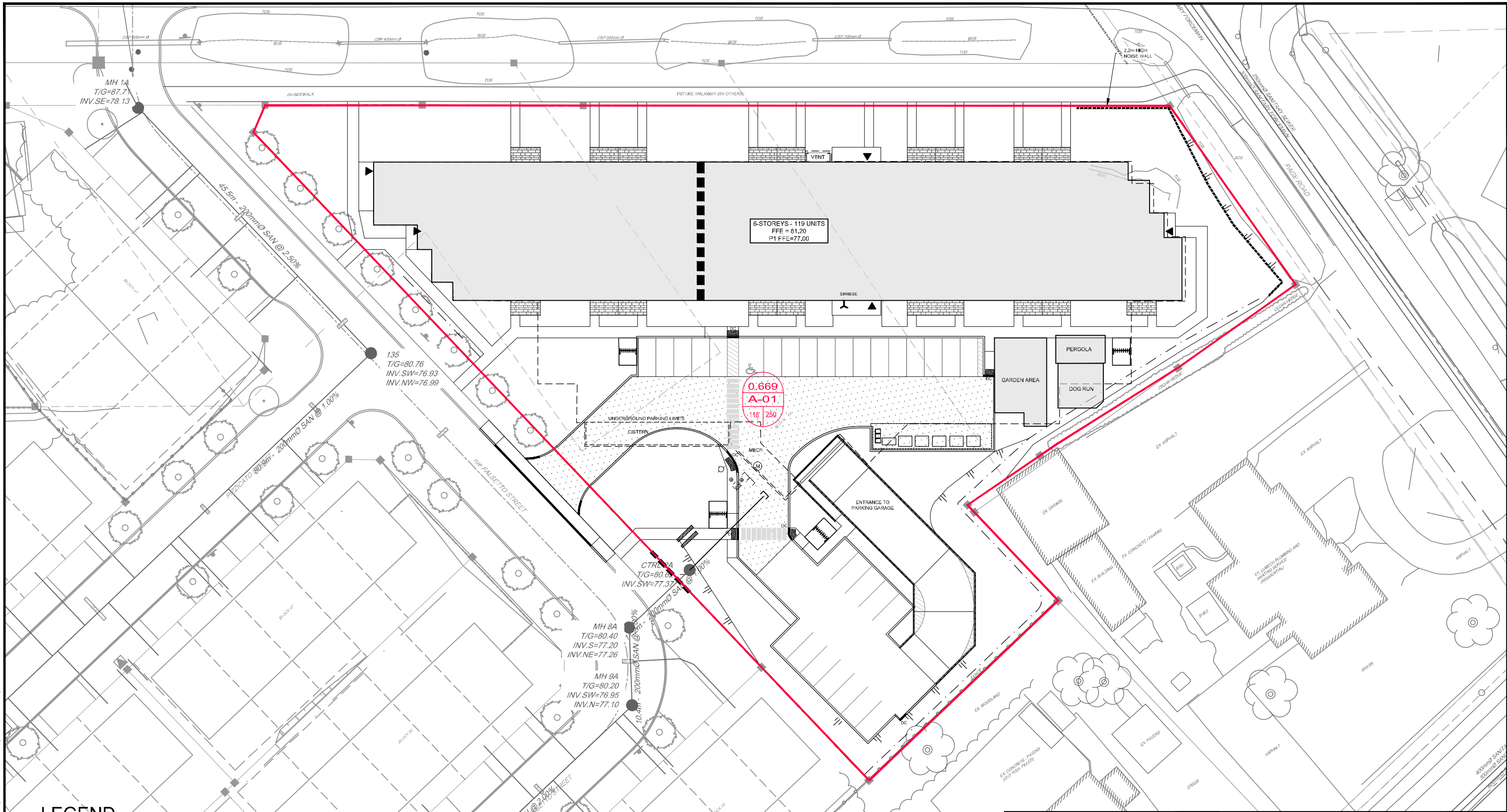
Max Day + Fire Test = Max Day + Fire Flow - Finished Floor Elevation x 1.42197 PSI/m > 20 PSI

**Max Day + Fire (Connection #1) = 44.4 PSI**



**Appendix C**  
**Sanitary Servicing**

M:\2022\122180\CAD\Civil\122180-SAN.dwg, SAN, Apr 26, 2023 - 3:20pm, amestwarp



**LEGEND**

- PROPERTY LINE
- PROPOSED SANITARY SEWER AND MANHOLE
- EXISTING SANITARY MANHOLE & SEWER
- SANITARY SEWER DRAINAGE AREA BOUNDARY
- DRAINAGE AREA (ha)  
SAN SEWER PIPE RUN  
NO. UNITS/POPULATION



**NOVATECH**  
 Engineers, Planners & Landscape Architects  
 Suite 200, 240 Michael Cowpland Drive  
 Ottawa, Ontario, Canada K2M 1P6  
 Telephone (613) 254-9643  
 Facsimile (613) 254-5867  
 Website www.novatech-eng.com

CITY OF OTTAWA  
 3080 NAVAN ROAD  
 (RHYTHM APARTMENTS)

**SANITARY DRAINAGE  
 AREA PLAN**

SCALE	1 : 500	
DATE	AUGUST 2023	JOB
	122180	FIGURE
		SAN

Novatech Project #: 122180  
 Project Name: Rhythm  
 Date Prepared: 3/6/2023  
 Date Revised:  
 Input By: Anthony Mestwarp, P.Eng  
 Reviewed By: Greg MacDonald, P.Eng  
 Drawing Reference: 122180- SAN

Legend: PROJECT SPECIFIC INFO  
 USER DESIGN INPUT  
 CUMULATIVE CELL  
 CALCULATED DESIGN CELL OUTPUT

LOCATION			DEMAND													DESIGN CAPACITY											
AREA	FROM MH	TO MH	RESIDENTIAL FLOW					COMMERCIAL FLOW					EXTRANEIOUS FLOW			PROPOSED SEWER PIPE SIZING / DESIGN											
			1 Bed Apartment	2 Bed Apartment	3 Bed Apartment	POPULATION (in 1000's)	CUMULATIVE POPULATION (in 1000's)	PEAK FACTOR M	AVG POPULATION FLOW (L/s)	PEAKED DESIGN POP FLOW (L/s)	AREA (m <sup>2</sup> )	CUMULATIVE AREA (m <sup>2</sup> )	DESIGN COMMERCIAL FLOW (L/s)	COMMERICAL PEAK FACTOR	PEAKED COMMERCIAL FLOW	Total Area (ha.)	Accum. Area (ha.)	DESIGN EXTRAN. FLOW (L/s)	TOTAL DESIGN FLOW (L/s)	PIPE LENGTH (m)	PIPE SIZE (mm) AND MATERIAL	PIPE ID ACTUAL (m)	ROUGH. (n)	DESIGN GRADE (%)	CAPACITY (L/s)	FULL FLOW VELOCITY (m/s)	Qpeak Design / Qcap
A-01	BLDG	MAIN	32	63	24	0.252	0.252	3.49	0.82	2.84	100.000	100.000	0.04	1.00	0.04	0.67	0.67	0.22	3.10		200 PVC	0.203	0.013	1.00	34.2	1.06	9.1%

Design Parameters:			
<b>1. Residential Flows</b>			
-1 Bed Apartment	1.4	Person/ Unit	As per City of Ottawa Sewer Design Guidelines, 2012
-2 Bed Apartment	2.1	Person/ Unit	
-3 Bed Apartment	3.1	Person/ Unit	
<b>2. Commercial Flow</b>			
-Retail Area (451.95m <sup>2</sup> )	125	L/seat/day	As per OBC Section 8.2
3. Q Avg capita flow	280	L/capita/day	As per City of Ottawa - Technical Bulletin ISTB-2018-01
4. M = Harmon Formula (maximum of 4.0)			As per Harmon Formula
5. K =	0.8		
6. Commercial Peak Factor	1.0		As per City of Ottawa - Technical Bulletin ISTB-2018-01
7. Peak Extraneous Flow =	0.33	L/sec/ha	

(\*assumed 1 seat/4m<sup>2</sup>)

**CAPACITY EQUATION**  
 $Q_{full} = (1/n) A R^{2/3} S_o^{1/2}$

Where : Q full = Capacity (L/s)

n = Manning coefficient of roughness (0.013)  
 A = Flow area (m<sup>2</sup>)  
 R = Wetted perimeter (m)  
 So = Pipe Slope/gradient




**SANITARY SEWER DESIGN SHEET**

**CAIVAN RHYTHM**

City of Ottawa

**PROJECT DETAILS**

Project No: 20-647-0  
 Date: 8-Aug-22  
 Designed by: T.L.  
 Checked by: J.O.



**DESIGN CRITERIA**

Min Diameter = 200 mm	Avg. Domestic Flow = 280.0 l/c/d
Mannings 'n' = 0.013	Infiltration = 0.330 l/s/ha
Min. Velocity = 0.60 m/s	Max. Peaking Factor = 4.00
Max. Velocity = 3.00 m/s	Min. Peaking Factor = 2.00

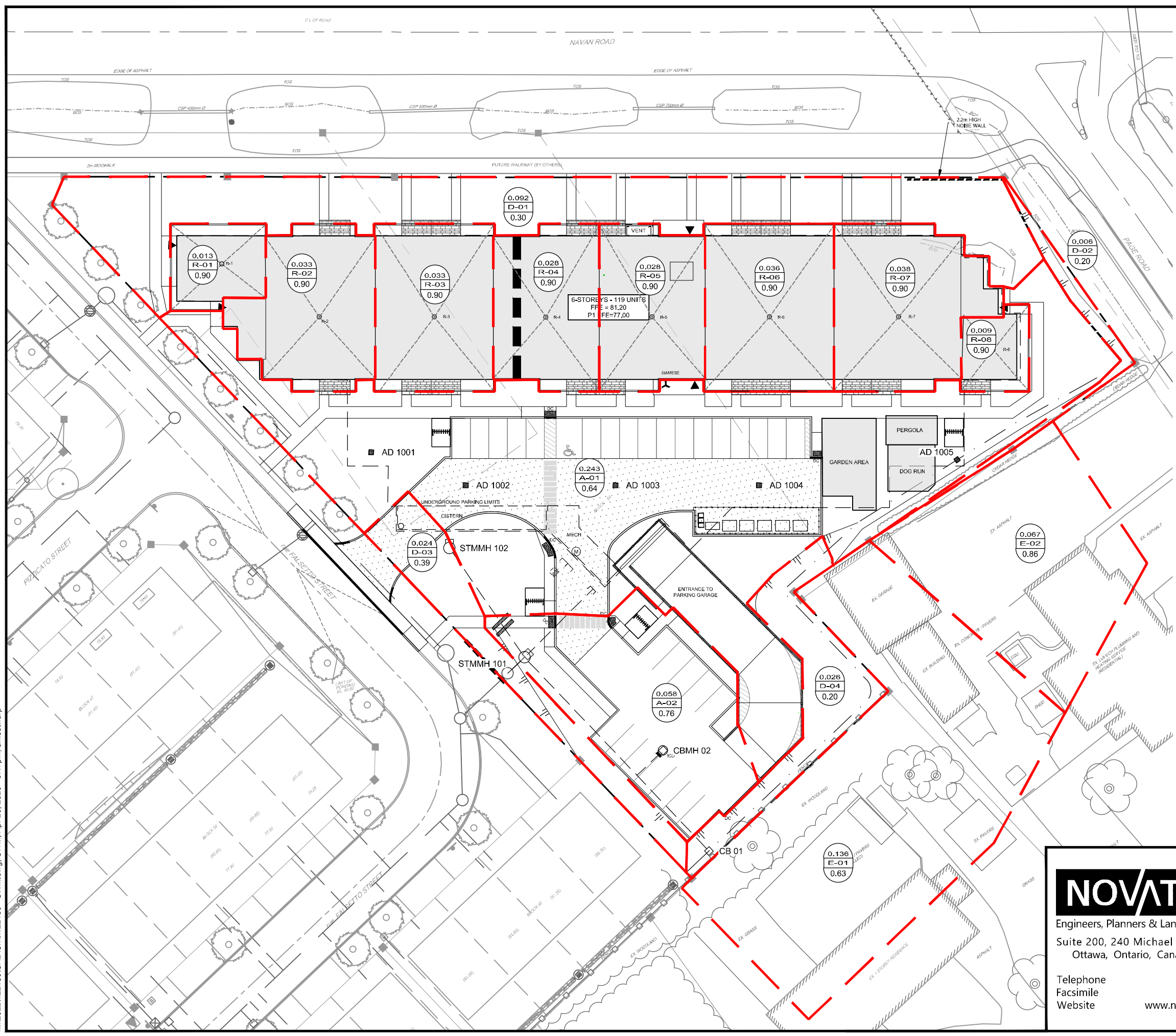
**NOMINAL PIPE SIZE USED**

STREET	FROM MH	TO MH	RESIDENTIAL							COMMERCIAL/INDUSTRIAL/INSTITUTIONAL							FLOW CALCULATIONS							PIPE DATA					
			AREA (ha)	ACC. AREA (ha)	UNITS (#)	DENISTY (P/ha)	DENSITY (P/unit)	POP	ACCUM. RES. POP.	AREA (ha)	ACC. AREA (ha)	EQUIV. POP. (p/ha)	FLOW RATE (l/s/ha)	EQUIV. POP.	ACCUM. EQUIV. POP.	INFILTRATION (l/s)	TOTAL ACCUM. POP.	PEAKING FACTOR	RES. FLOW (l/s)	COMM. FLOW (l/s)	ACCUM. COMM. FLOW (l/s)	TOTAL FLOW (l/s)	SLOPE (%)	PIPE DIAMETER (mm)	FULL FLOW CAPACITY (l/s)	FULL FLOW VELOCITY (m/s)	ACTUAL VELOCITY (m/s)	PERCENT FULL (%)	
rue FALSETTO STREET	1A	2A	0.23	0.23	5		2.7	14	14								0.1	14	4.00	0.2			0.3	2.50	200	51.9	1.65	0.43	0%
rue PIZZICATO STREET	2A	3A	0.34	0.57	12		2.7	33	47								0.2	47	4.00	0.6			0.8	2.00	200	46.4	1.48	0.46	2%
FUTURE DEVELOPMENT		CTRL 1A	2.08	2.08		60		125	125								0.7	125	3.57	1.4			2.1						
	CTRL 1A	3A	0.02	2.10					125								0.7	125	3.57	1.4			2.1	1.00	200	32.8	1.04	0.60	7%
rue PIZZICATO STREET		3A			13		2.7	36	36									36	3.67	0.4			0.4						
rue PIZZICATO STREET	3A	4A	0.38	3.05	1		3.4	4	212								1.0	212	3.51	2.4			3.4	2.00	200	46.4	1.48	0.84	7%
rue PIZZICATO STREET	4A	5A	0.16	3.21	4		3.4	14	226								1.1	226	3.50	2.6			3.6	1.00	200	32.8	1.04	0.69	11%
rue PIZZICATO STREET		5A			2		2.7	6	6									6	3.75	0.1			0.1						
rue PIZZICATO STREET	5A	6A	0.12	3.33	1		3.4	4	236								1.1	236	3.50	2.7			3.8	1.00	200	32.8	1.04	0.70	12%
rue PIZZICATO STREET	6A	7A	0.45	3.78	15		2.7	41	277								1.2	277	3.47	3.1			4.4	0.70	200	27.4	0.87	0.64	16%
BLOCK 64	CTRL 2A	8A	0.67	0.67	150		1.9	285	285								0.2	285	3.47	3.2			3.4	1.00	200	32.8	1.04	0.67	10%
rue FALSETTO STREET	8A	9A	0.13	0.80	1		2.7	3	288								0.3	288	3.47	3.2			3.5	1.00	200	32.8	1.04	0.69	11%
rue FALSETTO STREET	9A	10A	0.43	1.23	17		2.7	46	334								0.4	334	3.45	3.7			4.1	2.00	200	46.4	1.48	0.92	9%
rue FALSETTO STREET	10A	11A	0.41	1.64	16		2.7	44	378								0.5	378	3.43	4.2			4.7	2.00	200	46.4	1.48	0.94	10%
ruelle TENUTO LANE	12A	11A	0.19	0.19	5		2.7	14	14								0.1	14	3.72	0.2			0.2	2.00	200	46.4	1.48	0.38	0%
rue FALSETTO STREET	11A	7A	0.21	2.04	7		2.7	19	411								0.7	411	3.41	4.5			5.2	1.00	200	32.8	1.04	0.76	16%
rue FALSETTO STREET	7A	13A	0.09	5.91	1		2.7	3	691								2.0	691	3.32	7.4			9.4	1.00	200	32.8	1.04	0.89	29%
rue FALSETTO STREET		13A		5.91					691								2.0	691	3.32	7.4			9.4	1.00	200	32.8	1.04	0.89	29%
ruelle MARCATO LANE	14A	15A	0.26	0.26	7		2.7	19	19								0.1	19	3.71	0.2			0.3	2.00	200	46.4	1.48	0.38	1%
rue FALSETTO STREET	15A	16A		6.17					710								2.0	710	3.31	7.6			9.7	1.00	200	32.8	1.04	0.89	29%
rue FALSETTO STREET		17A			13		2.7	36	36									36	3.67	0.4			0.4						
	17A	18A	0.79	0.79	9		3.4	31	67								0.3	67	3.63	0.8			1.0	3.50	200	61.4	1.95	0.61	2%
rue FALSETTO STREET		18A			10		2.7	27	27									27	3.69	0.3			0.3						
rue FALSETTO STREET	18A	19A	0.54	1.33	8		3.4	28	122								0.4	122	3.58	1.4			1.9	1.00	200	32.8	1.04	0.56	6%
rue FALSETTO STREET	19A	20A	0.65	1.98	25		2.7	68	190								0.7	190	3.52	2.2			2.8	0.50	200	23.2	0.74	0.49	12%
rue FALSETTO STREET	20A	16A	0.07	2.05	1		2.7	3	193								0.7	193	3.52	2.2			2.9	1.00	200	32.8	1.04	0.65	9%
BLOCK 62	16A	21A	0.03	8.25					903								2.7	903	3.26	9.5			12.3	1.00	200	32.8	1.04	0.94	37%

**Appendix D**  
**Storm Servicing**



M:\2022\122180\CAD\Civil\122180 - SWM.dwg, SWM, Apr 26, 2023 - 3:47pm, amestwarp



### LEGEND

- DRAINAGE AREA LIMITS
- 0.085  
A-16  
0.78 DRAINAGE AREA (ha)  
DRAINAGE AREA ID  
RUNOFF COEFFICIENT
- PROPERTY LINE
- PROPOSED CURB
- DC PROPOSED DEPRESSED CURB
- FC PROPOSED FLUSH CURB
- PROPOSED RETAINING WALL C/W GUARD RAIL
- PROPOSED CAP
- PROPOSED STORM SEWER AND MANHOLE
- PROPOSED CATCHBASIN MANHOLE
- PROPOSED CATCHBASIN
- PROPOSED AREA DRAIN
- PROPOSED TRENCH DRAIN
- ICD PROPOSED INLET CONTROL DEVICE
- PROPOSED BUILDING ENTRANCE
- PROPOSED FIREWALL
- ▶ DIRECTION OF FLOW
- STMMH EXISTING STORM MANHOLE & SEWER
- CB 1 EXISTING CATCHBASIN

**NOVATECH**  
 Engineers, Planners & Landscape Architects  
 Suite 200, 240 Michael Cowpland Drive  
 Ottawa, Ontario, Canada K2M 1P6  
 Telephone (613) 254-9643  
 Facsimile (613) 254-5867  
 Website www.novatech-eng.com

CITY OF OTTAWA  
 3080 NAVAN ROAD  
 (RHYTHM APARTMENTS)

### STORMWATER MANAGEMENT PLAN

SCALE	1 : 500	
DATE	AUGUST 2022	FIGURE
JOB	122180	SWM

STORM SEWER DESIGN SHEET

Novatech Project #: 122180  
 Project Name:  
 Date Prepared: 3/8/2023  
 Date Revised:  
 Input By: Anthony Mestwarp, P.Eng  
 Reviewed By: Greg MacDonald, P.Eng  
 Drawing Reference: 122180-SWM

Legend: PROJECT SPECIFIC INFO  
 USER DESIGN INPUT  
 CUMILATIVE CELL  
 CALCULATED DESIGN CELL OUTPUT  
 USER AS-BUILT INPUT

LOCATION		DEMAND										CAPACITY																
From MH	To MH	Area ID	AREA			Weighted Runoff Coefficient	Indivi 2.78 AR	Accum 2.78 AR	Time of Concentration (min.)	Rain Intensity (mm/hr)			Peak Flow (L/s)	TOTAL UNRESTRICTED PEAK FLOW (QDesign) (L/s)	PIPE PROPERTIES					CAPACITY (L/s)	FULL FLOW VELOCITY (m/s)	TIME OF FLOW (min.)	QPEAK DESIGN / QFULL (%)					
			Hardscape	Landscaping	Total Area (ha)					2yr	5yr	100yr			LENGTH (m)	SIZE / MATERIAL (mm / type)	ID ACTUAL (m)	ROUGHNESS	DESIGN GRADE (%)									
Private Storm Sewer																												
CB-01	STMMH 103	EX-01	0.000				0.00																					
			0.000				0.00																					
			0.082	0.053	0.136	0.75	0.28																					
		A-02	0.046	0.012	0.058	0.76	0.12																					
			0.000				0.00																					
			0.000				0.00																					
D-04	0.000	0.026	0.026	0.20	0.01	0.01	10.00	76.81			1.10	51.6	34.6	375 PVC	0.381	0.013	0.50	129.3	1.13	0.51	39.9%							
	0.000				0.00	0.00	10.00			0.00																		
	0.000				0.00	0.28	10.00			178.56	50.53																	
CISTERN	STMMH 102	A-01	0.152	0.091	0.243	0.64	0.43	0.43	10.00	76.81		33.18	33.2	1.1	250 PVC	0.254	0.013	1.00	62.0	1.22	0.01	53.5%						
			0.000				0.00	0.00	10.00		0.00																	
			0.000				0.00	0.00	10.00		0.00																	
STMMH 102	STMMH 101		0.000				0.00	0.43	10.01	76.75		33.15	33.2	17.2	250 PVC	0.254	0.013	0.50	43.9	0.87	0.33	75.6%						
			0.000				0.00	0.00	10.01		0.00																	
			0.000				0.00	0.00	10.01		0.00																	
BUILDING	STMMH 101	ROOF	0.219	0.000	0.219	0.90	0.55	0.55	10.00	76.81		42.08	42.1	12.5	250 PVC	0.254	0.013	1.00	62.0	1.22	0.17	67.8%						
			0.000				0.00	0.00	10.00		0.00																	
			0.000				0.00	0.00	10.00		0.00																	
STMMH 101	EX STM		0.000				0.00	0.99	10.51	74.91		74.48	123.7	3.0	375 PVC	0.381	0.013	1.00	182.9	1.60	0.03	67.6%						
			0.000				0.00	0.00	10.51		0.00																	
			0.000				0.00	0.28	10.51		174.04	49.25																

**DEMAND EQUATION**  
 $Q = 2.78 \text{ AIR}$

Where : Q = Peak flow in litres per second (L/s)  
 A = Area in hectares (ha)  
 R = Weighted runoff coefficient (increased by 25% for 100-year)  
 I = Rainfall intensity in millimeters per hour (mm/hr)  
 Rainfall Intensity (I) is based on City of Ottawa IDF data presented in the City of Ottawa Sewer Design Guidelines (Oct. 2012)

**CAPACITY EQUATION**  
 $Q_{full} = (1/n) A R^{(2/3)} S_o^{(1/2)}$

Where : Q full = Capacity (L/s)  
 n = Manning coefficient of roughness (0.013)  
 A = Flow area (m<sup>2</sup>)  
 R = Wetted perimeter (m)  
 S<sub>o</sub> = Pipe Slope/gradient



**TABLE 1A: Allowable Runoff Coefficient "C"**

Drainage Area	Area (HA)	"C"
Block 64	0.67	0.20
Total	0.67	0.20

Site Constraints	85	L/s/ha
------------------	----	--------

\* Constraints as per Design Report and SWM Brief, Caivan Rhythm Residential Development, 7th Submission, Aug 2022, Prepared by Urbantech

**TABLE 1B: Allowable Flows**

Outlet Options	Area (ha)	Q <sub>ALLOW</sub> (L/s)
Caivan Rhythm Residential Development	0.669	<b>56.9</b>

**TABLE 2A: Post-Development Runoff Coefficient "C" - D-01**

Area	Surface	Ha	"C"	C <sub>avg</sub>	*C <sub>100</sub>
Total	Hard	0.013	0.90	0.30	0.35
0.092	Soft	0.080	0.20		

Runoff Coefficient Equation  
 $C = (A_{hard} \times 0.9 + A_{soft} \times 0.2) / A_{Tot}$   
 \* Runoff Coefficient increases by 25% up to a maximum value of 1.00 for the 100-Year event

**TABLE 2B: Post-Development D-01 Flows**

Outlet Options	Area (ha)	C <sub>avg</sub>	Tc (min)	Q <sub>2 Year</sub> (L/s)	Q <sub>5 Year</sub> (L/s)	Q <sub>100 Year</sub> (L/s)
Navan Road	0.092	0.30	10	5.9	8.0	16.2

Time of Concentration T<sub>c</sub>= 10 min  
 Intensity (2 Year Event) I<sub>2</sub>= 76.81 mm/hr  
 Intensity (5 Year Event) I<sub>5</sub>= 104.19 mm/hr  
 Intensity (100 Year Event) I<sub>100</sub>= 178.56 mm/hr

Equations:  
 Flow Equation  
 $Q = 2.78 \times C \times I \times A$   
 Where:

C is the runoff coefficient  
 I is the rainfall intensity, City of Ottawa IDF  
 A is the total drainage area

100 year Intensity =  $1735.688 / (\text{Time in min} + 6.014)^{0.820}$   
 5 year Intensity =  $998.071 / (\text{Time in min} + 6.053)^{0.814}$   
 2 year Intensity =  $732.951 / (\text{Time in min} + 6.199)^{0.810}$

**TABLE 3A: Post-Development Runoff Coefficient "C" - D-02**

Area	Surface	Ha	"C"	C <sub>avg</sub>	*C <sub>100</sub>
Total	Hard	0.000	0.90	0.20	0.25
0.006	Soft	0.006	0.20		

Runoff Coefficient Equation  
 $C = (A_{hard} \times 0.9 + A_{soft} \times 0.2) / A_{Tot}$   
 \* Runoff Coefficient increases by 25% up to a maximum value of 1.00 for the 100-Year event

**TABLE 3B: Post-Development D-02 Flows**

Outlet Options	Area (ha)	C <sub>avg</sub>	Tc (min)	Q <sub>2 Year</sub> (L/s)	Q <sub>5 Year</sub> (L/s)	Q <sub>100 Year</sub> (L/s)
Page Road	0.006	0.20	10	0.3	0.4	0.8

Time of Concentration Tc= 10 min  
 Intensity (2 Year Event) I<sub>2</sub>= 76.81 mm/hr  
 Intensity (5 Year Event) I<sub>5</sub>= 104.19 mm/hr  
 Intensity (100 Year Event) I<sub>100</sub>= 178.56 mm/hr

Equations:  
 Flow Equation  
 $Q = 2.78 \times C \times I \times A$   
 Where:

C is the runoff coefficient  
 I is the rainfall intensity, City of Ottawa IDF  
 A is the total drainage area

100 year Intensity =  $1735.688 / (\text{Time in min} + 6.014)^{0.820}$   
 5 year Intensity =  $998.071 / (\text{Time in min} + 6.053)^{0.814}$   
 2 year Intensity =  $732.951 / (\text{Time in min} + 6.199)^{0.810}$

**TABLE 4A: Post-Development Runoff Coefficient "C" - D-03**

Area	Surface	Ha	"C"	C <sub>avg</sub>	*C <sub>100</sub>
Total	Hard	0.007	0.90	0.39	0.46
0.024	Soft	0.017	0.20		

Runoff Coefficient Equation  
 $C = (A_{hard} \times 0.9 + A_{soft} \times 0.2) / A_{Tot}$   
 \* Runoff Coefficient increases by 25% up to a maximum value of 1.00 for the 100-Year event

**TABLE 4B: Post-Development D-03 Flows**

Outlet Options	Area (ha)	C <sub>avg</sub>	Tc (min)	Q <sub>2 Year</sub> (L/s)	Q <sub>5 Year</sub> (L/s)	Q <sub>100 Year</sub> (L/s)
Falsetto Street	0.024	0.39	10	2.0	2.7	5.4

Time of Concentration Tc= 10 min  
 Intensity (2 Year Event) I<sub>2</sub>= 76.81 mm/hr  
 Intensity (5 Year Event) I<sub>5</sub>= 104.19 mm/hr  
 Intensity (100 Year Event) I<sub>100</sub>= 178.56 mm/hr

Equations:  
 Flow Equation  
 $Q = 2.78 \times C \times I \times A$   
 Where:

C is the runoff coefficient  
 I is the rainfall intensity, City of Ottawa IDF  
 A is the total drainage area

100 year Intensity =  $1735.688 / (\text{Time in min} + 6.014)^{0.820}$   
 5 year Intensity =  $998.071 / (\text{Time in min} + 6.053)^{0.814}$   
 2 year Intensity =  $732.951 / (\text{Time in min} + 6.199)^{0.810}$

**TABLE 5A: Post-Development Runoff Coefficient "C" - D-04**

Area	Surface	Ha	"C"	C <sub>avg</sub>	*C <sub>100</sub>
Total	Hard	0.000	0.90	0.20	0.25
0.026	Soft	0.026	0.20		

Runoff Coefficient Equation  
 $C = (A_{hard} \times 0.9 + A_{soft} \times 0.2) / A_{Tot}$   
 \* Runoff Coefficient increases by 25% up to a maximum value of 1.00 for the 100-Year event

**TABLE 5B: Post-Development D-04 Flows**

Outlet Options	Area (ha)	C <sub>avg</sub>	Tc (min)	Q <sub>2 Year</sub> (L/s)	Q <sub>5 Year</sub> (L/s)	Q <sub>100 Year</sub> (L/s)
Falsetto Street	0.026	0.20	10	1.1	1.5	3.2

Time of Concentration Tc= 10 min  
 Intensity (2 Year Event) I<sub>2</sub>= 76.81 mm/hr  
 Intensity (5 Year Event) I<sub>5</sub>= 104.19 mm/hr  
 Intensity (100 Year Event) I<sub>100</sub>= 178.56 mm/hr

Equations:  
 Flow Equation  
 $Q = 2.78 \times C \times I \times A$   
 Where:

C is the runoff coefficient  
 I is the rainfall intensity, City of Ottawa IDF  
 A is the total drainage area

100 year Intensity =  $1735.688 / (\text{Time in min} + 6.014)^{0.820}$   
 5 year Intensity =  $998.071 / (\text{Time in min} + 6.053)^{0.814}$   
 2 year Intensity =  $732.951 / (\text{Time in min} + 6.199)^{0.810}$

**TABLE 6A: Post-Development Runoff Coefficient "C" - R-01**

Area	Surface	Ha	5 Year Event		100 Year Event	
			"C"	C <sub>avg</sub>	"C" + 25%	*C <sub>avg</sub>
Total	Hard	0.000	0.90	0.90	1.00	1.00
0.013	Roof	0.013	0.90		1.00	
	Soft	0.000	0.20		0.25	

**TABLE 6B: 2 YEAR EVENT QUANTITY STORAGE REQUIREMENT - R-01**

0.013 =Area (ha)  
 0.90 = C

Return Period	Time (min)	Intensity (mm/hr)	Flow Q (L/s)	Allowable Runoff (L/s)	Net Flow to be Stored (L/s)	Storage Req'd (m <sup>3</sup> )
2 YEAR	10	76.81	2.51	0.728	1.78	1.07
	15	61.77	2.02	0.728	1.29	1.16
	<b>20</b>	<b>52.03</b>	<b>1.70</b>	<b>0.728</b>	<b>0.97</b>	<b>1.16</b>
	25	45.17	1.47	0.728	0.75	1.12
	30	40.04	1.31	0.728	0.58	1.04

**TABLE 6C: 5 YEAR EVENT QUANTITY STORAGE REQUIREMENT - R-01**

0.0130436 =Area (ha)  
 0.90 = C

Return Period	Time (min)	Intensity (mm/hr)	Flow Q (L/s)	Allowable Runoff (L/s)	Net Flow to be Stored (L/s)	Storage Req'd (m <sup>3</sup> )
5 YEAR	15	83.56	2.73	0.776	1.95	1.76
	20	70.25	2.29	0.776	1.52	1.82
	<b>25</b>	<b>60.90</b>	<b>1.99</b>	<b>0.776</b>	<b>1.21</b>	<b>1.82</b>
	30	53.93	1.76	0.776	0.98	1.77
	35	48.52	1.58	0.776	0.81	1.70

**TABLE 6D: 100 YEAR EVENT QUANTITY STORAGE REQUIREMENT - R-01**

0.0130436 =Area (ha)  
 1.00 = C

Return Period	Time (min)	Intensity (mm/hr)	Flow Q (L/s)	Allowable Runoff (L/s)	Net Flow to be Stored (L/s)	Storage Req'd (m <sup>3</sup> )
100 YEAR	25	103.85	3.77	0.886	2.88	4.32
	30	91.87	3.33	0.886	2.45	4.40
	<b>35</b>	<b>82.58</b>	<b>2.99</b>	<b>0.886</b>	<b>2.11</b>	<b>4.43</b>
	40	75.15	2.72	0.886	1.84	4.41
	45	69.05	2.50	0.886	1.62	4.37

Equations:

Flow Equation

$$Q = 2.78 \times C \times I \times A$$

Where:

C is the runoff coefficient

I is the rainfall intensity, City of Ottawa IDF

A is the total drainage area

Runoff Coefficient Equation

$$C_s = (A_{\text{hard}} \times 0.9 + A_{\text{soft}} \times 0.2) / A_{\text{Tot}}$$

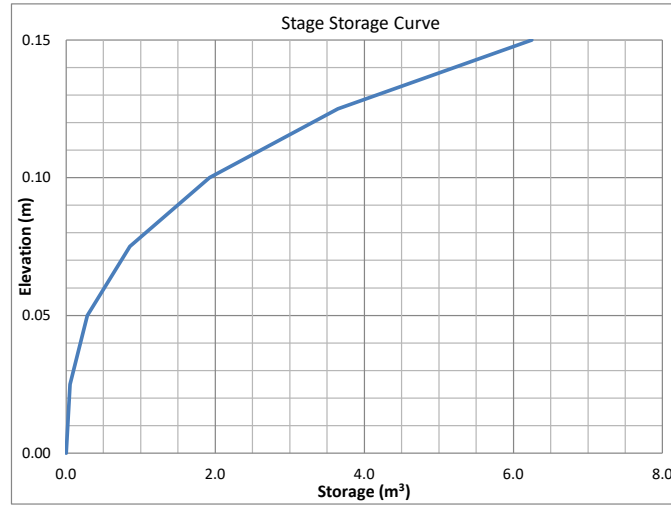
$$C_{100} = (A_{\text{hard}} \times 1.0 + A_{\text{soft}} \times 0.25) / A_{\text{Tot}}$$



**TABLE 6E: Storage Provided - R-01**

Area R-01: Storage Table			
Head (m)	Area* (m <sup>2</sup> )	Storage Volume (m <sup>3</sup> )	
0.000	0.062	0.00	
0.025	4.105	0.05	
0.050	14.481	0.28	
0.075	31.191	0.86	
0.100	54.234	1.92	
0.125	83.611	3.65	
0.150	124.288	6.24	

\* Area of ponding based on preliminary roof plans. Areas and storage will be updated once a mechanical engineer is retained



**Table 6F: Roof Drain Flows**

Roof Drains		
Roof Area	130.436	m <sup>2</sup>
Qty	1	
Type	Accutrol RD-100-A-ADJ	
Setting	1/4 Open	
Design Head	0.05-0.15	m
Design Flow 1" of head	0.32	L/s (ea)
Design Flow 2" of head	0.63	L/s (ea)
Design Flow 3" of head	0.71	L/s (ea)
Design Flow 4" of head	0.79	L/s (ea)
Design Flow 5" of head	0.87	L/s (ea)
Design Flow 6" of head	0.95	L/s (ea)

**Table 6G: Total Roof Storage**

Design Event	Roof Drain ID	Flow (L/S)	Head m	Required Volume
2 Year	R-01	0.728	0.082	1.16
5 Year		0.776	0.098	1.82
100 Year		0.886	0.133	4.43

**TABLE 7A: Post-Development Runoff Coefficient "C" - R-02**

Area	Surface	Ha	5 Year Event		100 Year Event	
			"C"	C <sub>avg</sub>	"C" + 25%	*C <sub>avg</sub>
Total	Hard	0.000	0.90	0.90	1.00	1.00
0.033	Roof	0.033	0.90		1.00	
	Soft	0.000	0.20		0.25	

**TABLE 7B: 2 YEAR EVENT QUANTITY STORAGE REQUIREMENT - R-02**

0.033 =Area (ha)  
 0.90 = C

Return Period	Time (min)	Intensity (mm/hr)	Flow Q (L/s)	Allowable Runoff (L/s)	Net Flow to be Stored (L/s)	Storage Req'd (m <sup>3</sup> )
2 YEAR	20	52.03	4.28	1.070	3.21	3.85
	25	45.17	3.71	1.070	2.64	3.96
	<b>30</b>	<b>40.04</b>	<b>3.29</b>	<b>1.070</b>	<b>2.22</b>	<b>4.00</b>
	35	36.06	2.96	1.070	1.89	3.98
	40	32.86	2.70	1.070	1.63	3.92

**TABLE 7C: 5 YEAR EVENT QUANTITY STORAGE REQUIREMENT - R-02**

0.0328533 =Area (ha)  
 0.90 = C

Return Period	Time (min)	Intensity (mm/hr)	Flow Q (L/s)	Allowable Runoff (L/s)	Net Flow to be Stored (L/s)	Storage Req'd (m <sup>3</sup> )
5 YEAR	30	53.93	4.43	1.117	3.32	5.97
	35	48.52	3.99	1.117	2.87	6.03
	<b>40</b>	<b>44.18</b>	<b>3.63</b>	<b>1.117</b>	<b>2.51</b>	<b>6.04</b>
	45	40.63	3.34	1.117	2.22	6.00
	50	37.65	3.10	1.117	1.98	5.93

**TABLE 7D: 100 YEAR EVENT QUANTITY STORAGE REQUIREMENT - R-02**

0.0328533 =Area (ha)  
 1.00 = C

Return Period	Time (min)	Intensity (mm/hr)	Flow Q (L/s)	Allowable Runoff (L/s)	Net Flow to be Stored (L/s)	Storage Req'd (m <sup>3</sup> )
100 YEAR	40	75.15	6.86	1.572	5.29	12.70
	45	69.05	6.31	1.57	4.73	12.78
	<b>50</b>	<b>63.95</b>	<b>5.84</b>	<b>1.57</b>	<b>4.27</b>	<b>12.81</b>
	55	59.62	5.45	1.57	3.87	12.78
	60	55.89	5.10	1.57	3.53	12.72

Equations:

Flow Equation

$$Q = 2.78 \times C \times I \times A$$

Where:

C is the runoff coefficient

I is the rainfall intensity, City of Ottawa IDF

A is the total drainage area

Runoff Coefficient Equation

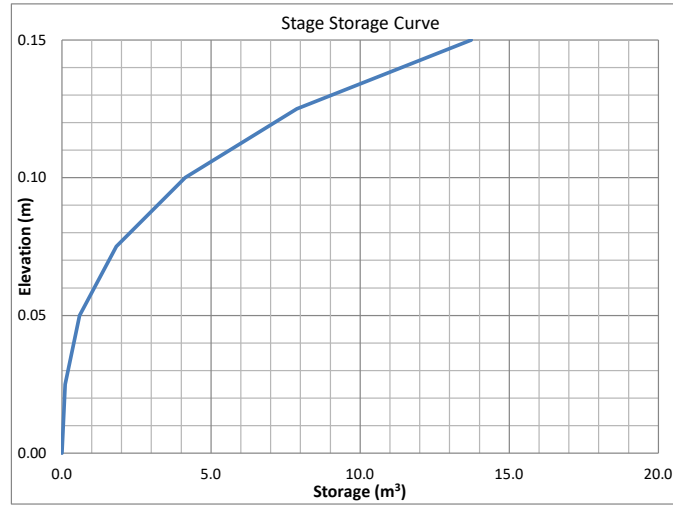
$$C_s = (A_{\text{hard}} \times 0.9 + A_{\text{soft}} \times 0.2) / A_{\text{Tot}}$$

$$C_{100} = (A_{\text{hard}} \times 1.0 + A_{\text{soft}} \times 0.25) / A_{\text{Tot}}$$

**TABLE 7E: Storage Provided - R-02**

Area R-02: Storage Table		
Head (m)	Area* (m <sup>2</sup> )	Storage Volume (m <sup>3</sup> )
0.000	0.062	0.00
0.025	8.415	0.11
0.050	30.805	0.60
0.075	67.233	1.82
0.100	117.698	4.13
0.125	182.201	7.88
0.150	285.375	13.73

\* Area of ponding based on preliminary roof plans. Areas and storage will be updated once a mechanical engineer is retained



**Table 7F: Roof Drain Flows**

Roof Drains	
Roof Area	328.533 m <sup>2</sup>
Qty	1
Type	Accutrol RD-100-A-ADJ
Setting	3/4 Open
Design Head	0.05-0.15 m
Design Flow 1" of head	0.32 L/s (ea)
Design Flow 2" of head	0.63 L/s (ea)
Design Flow 3" of head	0.87 L/s (ea)
Design Flow 4" of head	1.10 L/s (ea)
Design Flow 5" of head	1.34 L/s (ea)
Design Flow 6" of head	1.58 L/s (ea)

**Table 7G: Total Roof Storage**

Design Event	Roof Drain ID	Flow (L/S)	Head (m)	Required Volume
2 Year	R-02	1.070	0.098	4.00
5 Year		1.117	0.113	6.04
100 Year		1.572	0.146	12.81

**TABLE 8A: Post-Development Runoff Coefficient "C" - R-03**

Area	Surface	Ha	5 Year Event		100 Year Event	
			"C"	C <sub>avg</sub>	"C" + 25%	*C <sub>avg</sub>
Total	Hard	0.000	0.90	0.90	1.00	1.00
0.033	Roof	0.033	0.90		1.00	
	Soft	0.000	0.20		0.25	

**TABLE 8B: 2 YEAR EVENT QUANTITY STORAGE REQUIREMENT - R-03**

0.033 =Area (ha)  
 0.90 = C

Return Period	Time (min)	Intensity (mm/hr)	Flow Q (L/s)	Allowable Runoff (L/s)	Net Flow to be Stored (L/s)	Storage Req'd (m <sup>3</sup> )
2 YEAR	25	45.17	3.76	0.930	2.83	4.25
	30	40.04	3.34	0.930	2.41	4.33
	<b>35</b>	<b>36.06</b>	<b>3.01</b>	<b>0.930</b>	<b>2.08</b>	<b>4.36</b>
	40	32.86	2.74	0.930	1.81	4.34
	45	30.24	2.52	0.930	1.59	4.29

**TABLE 8C: 5 YEAR EVENT QUANTITY STORAGE REQUIREMENT - R-03**

0.0333088 =Area (ha)  
 0.90 = C

Return Period	Time (min)	Intensity (mm/hr)	Flow Q (L/s)	Allowable Runoff (L/s)	Net Flow to be Stored (L/s)	Storage Req'd (m <sup>3</sup> )
5 YEAR	30	53.93	4.49	1.011	3.48	6.27
	35	48.52	4.04	1.011	3.03	6.37
	<b>40</b>	<b>44.18</b>	<b>3.68</b>	<b>1.011</b>	<b>2.67</b>	<b>6.41</b>
	45	40.63	3.39	1.011	2.37	6.41
	50	37.65	3.14	1.011	2.13	6.38

**TABLE 8D: 100 YEAR EVENT QUANTITY STORAGE REQUIREMENT - R-03**

0.0333088 =Area (ha)  
 1.00 = C

Return Period	Time (min)	Intensity (mm/hr)	Flow Q (L/s)	Allowable Runoff (L/s)	Net Flow to be Stored (L/s)	Storage Req'd (m <sup>3</sup> )
100 YEAR	55	59.62	5.52	1.2280	4.29	14.17
	60	55.89	5.18	1.2280	3.95	14.21
	<b>65</b>	<b>52.65</b>	<b>4.87</b>	<b>1.2280</b>	<b>3.65</b>	<b>14.22</b>
	70	49.79	4.61	1.2280	3.38	14.21
	75	47.26	4.38	1.2280	3.15	14.17

Equations:

Flow Equation

$$Q = 2.78 \times C \times I \times A$$

Where:

C is the runoff coefficient

I is the rainfall intensity, City of Ottawa IDF

A is the total drainage area

Runoff Coefficient Equation

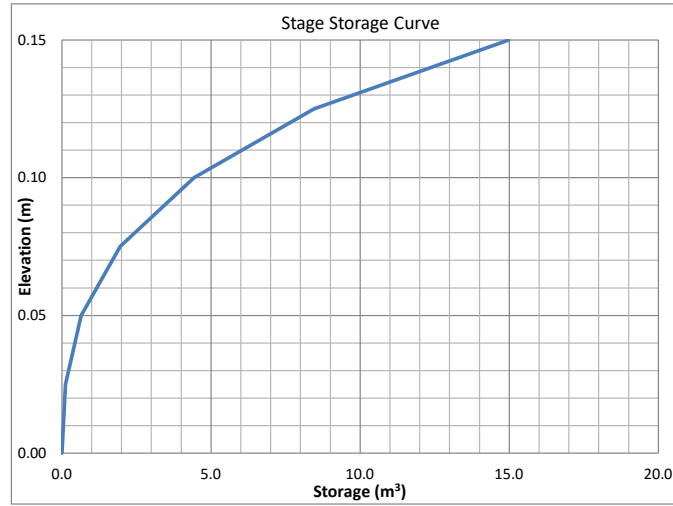
$$C_s = (A_{\text{hard}} \times 0.9 + A_{\text{soft}} \times 0.2) / A_{\text{Tot}}$$

$$C_{100} = (A_{\text{hard}} \times 1.0 + A_{\text{soft}} \times 0.25) / A_{\text{Tot}}$$

**TABLE 8E: Storage Provided - R-03**

Area R-03: Storage Table		
Head (m)	Area* (m <sup>2</sup> )	Storage Volume (m <sup>3</sup> )
0.000	0.610	0.00
0.025	8.983	0.12
0.050	32.985	0.64
0.075	72.071	1.96
0.100	126.238	4.44
0.125	195.489	8.46
0.150	326.374	14.98

\* Area of ponding based on preliminary roof plans. Areas and storage will be updated once a mechanical engineer is retained



**Table 8F: Roof Drain Flows**

Roof Drains		
Roof Area	333.088	m <sup>2</sup>
Qty	1	
Type	Accutrol RD-100-A-ADJ	
Setting	1/2 Open	
Design Head	0.05-0.15	m
Design Flow 1" of head	0.32	L/s (ea)
Design Flow 2" of head	0.63	L/s (ea)
Design Flow 3" of head	0.79	L/s (ea)
Design Flow 4" of head	0.95	L/s (ea)
Design Flow 5" of head	1.10	L/s (ea)
Design Flow 6" of head	1.26	L/s (ea)

**Table 8G: Total Roof Storage**

Design Event	Roof Drain ID	Flow (L/S)	Head m	Required Volume
2 Year	R-04	0.930	0.099	4.36
5 Year		1.011	0.112	6.41
100 Year		1.228	0.147	14.22

**TABLE 9A: Post-Development Runoff Coefficient "C" - R-04**

Area	Surface	Ha	5 Year Event		100 Year Event	
			"C"	C <sub>avg</sub>	"C" + 25%	*C <sub>avg</sub>
Total	Hard	0.000	0.90	0.90	1.00	1.00
0.028	Roof	0.028	0.90		1.00	
	Soft	0.000	0.20		0.25	

**TABLE 9B: 2 YEAR EVENT QUANTITY STORAGE REQUIREMENT - R-04**

0.028 =Area (ha)  
 0.90 = C

Return Period	Time (min)	Intensity (mm/hr)	Flow Q (L/s)	Allowable Runoff (L/s)	Net Flow to be Stored (L/s)	Storage Req'd (m <sup>3</sup> )
2 YEAR	25	45.17	3.16	0.768	2.40	3.59
	30	40.04	2.80	0.768	2.04	3.67
	<b>35</b>	<b>36.06</b>	<b>2.53</b>	<b>0.768</b>	<b>1.76</b>	<b>3.69</b>
	40	32.86	2.30	0.768	1.53	3.68
	45	30.24	2.12	0.768	1.35	3.64

**TABLE 9C: 5 YEAR EVENT QUANTITY STORAGE REQUIREMENT - R-04**

0.0279937 =Area (ha)  
 0.90 = C

Return Period	Time (min)	Intensity (mm/hr)	Flow Q (L/s)	Allowable Runoff (L/s)	Net Flow to be Stored (L/s)	Storage Req'd (m <sup>3</sup> )
5 YEAR	35	48.52	3.40	0.811	2.59	5.43
	40	44.18	3.09	0.811	2.28	5.48
	<b>45</b>	<b>40.63</b>	<b>2.85</b>	<b>0.811</b>	<b>2.03</b>	<b>5.49</b>
	50	37.65	2.64	0.811	1.83	5.48
	55	35.12	2.46	0.811	1.65	5.44

**TABLE 9D: 100 YEAR EVENT QUANTITY STORAGE REQUIREMENT - R-04**

0.0279937 =Area (ha)  
 1.00 = C

Return Period	Time (min)	Intensity (mm/hr)	Flow Q (L/s)	Allowable Runoff (L/s)	Net Flow to be Stored (L/s)	Storage Req'd (m <sup>3</sup> )
100 YEAR	60	55.89	4.35	0.920	3.43	12.35
	65	52.65	4.10	0.92	3.18	12.39
	<b>70</b>	<b>49.79</b>	<b>3.87</b>	<b>0.92</b>	<b>2.95</b>	<b>12.41</b>
	75	47.26	3.68	0.92	2.76	12.41
	80	44.99	3.50	0.92	2.58	12.39

Equations:

Flow Equation

$$Q = 2.78 \times C \times I \times A$$

Where:

C is the runoff coefficient

I is the rainfall intensity, City of Ottawa IDF

A is the total drainage area

Runoff Coefficient Equation

$$C_s = (A_{\text{hard}} \times 0.9 + A_{\text{soft}} \times 0.2) / A_{\text{Tot}}$$

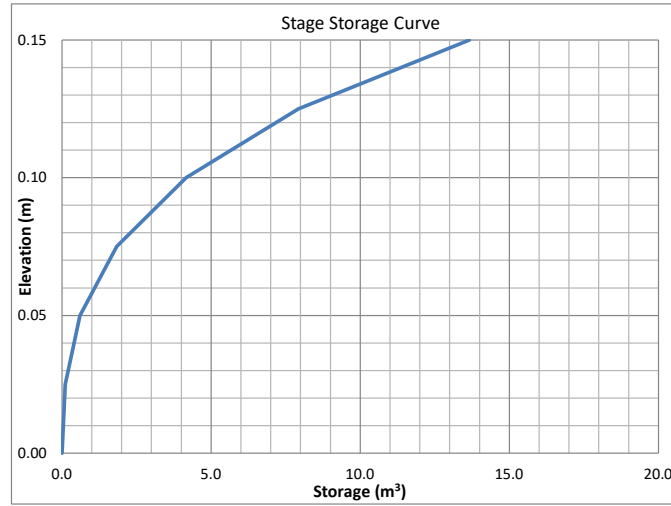
$$C_{100} = (A_{\text{hard}} \times 1.0 + A_{\text{soft}} \times 0.25) / A_{\text{Tot}}$$



**TABLE 9E: Storage Provided - R-04**

Area R-04: Storage Table		
Head (m)	Area* (m <sup>2</sup> )	Storage Volume (m <sup>3</sup> )
0.000	0.062	0.00
0.025	8.450	0.11
0.050	30.988	0.60
0.075	67.674	1.83
0.100	118.509	4.16
0.125	183.494	7.93
0.150	274.265	13.66

\* Area of ponding based on preliminary roof plans. Areas and storage will be updated once a mechanical engineer is retained



**Table 9F: Roof Drain Flows**

Roof Drains		
Roof Area	279.937	m <sup>2</sup>
Qty	1	
Type	Accutrol RD-100-A-ADJ	
Setting	1/4 Open	
Design Head	0.05-0.15	m
Design Flow 1" of head	0.32	L/s (ea)
Design Flow 2" of head	0.63	L/s (ea)
Design Flow 3" of head	0.71	L/s (ea)
Design Flow 4" of head	0.79	L/s (ea)
Design Flow 5" of head	0.87	L/s (ea)
Design Flow 6" of head	0.95	L/s (ea)

**Table 9G: Total Roof Storage**

Design Event	Roof Drain ID	Flow (L/S)	Head m	Required Volume
2 Year	R-04	0.768	0.095	3.69
5 Year		0.811	0.109	5.49
100 Year		0.920	0.144	12.41

**TABLE 10A: Post-Development Runoff Coefficient "C" - R-05**

Area	Surface	Ha	5 Year Event		100 Year Event	
			"C"	C <sub>avg</sub>	"C" + 25%	*C <sub>avg</sub>
Total	Hard	0.000	0.90	0.90	1.00	1.00
0.028	Roof	0.028	0.90		1.00	
	Soft	0.000	0.20		0.25	

**TABLE 10B: 2 YEAR EVENT QUANTITY STORAGE REQUIREMENT - R-05**

0.028 =Area (ha)  
 0.90 = C

Return Period	Time (min)	Intensity (mm/hr)	Flow Q (L/s)	Allowable Runoff (L/s)	Net Flow to be Stored (L/s)	Storage Req'd (m <sup>3</sup> )
2 YEAR	25	45.17	3.16	0.768	2.40	3.59
	30	40.04	2.80	0.768	2.04	3.67
	<b>35</b>	<b>36.06</b>	<b>2.53</b>	<b>0.768</b>	<b>1.76</b>	<b>3.69</b>
	40	32.86	2.30	0.768	1.53	3.68
	45	30.24	2.12	0.768	1.35	3.65

**TABLE 10C: 5 YEAR EVENT QUANTITY STORAGE REQUIREMENT - R-05**

0.0279961 =Area (ha)  
 0.90 = C

Return Period	Time (min)	Intensity (mm/hr)	Flow Q (L/s)	Allowable Runoff (L/s)	Net Flow to be Stored (L/s)	Storage Req'd (m <sup>3</sup> )
5 YEAR	35	48.52	3.40	0.811	2.59	5.43
	40	44.18	3.09	0.811	2.28	5.48
	<b>45</b>	<b>40.63</b>	<b>2.85</b>	<b>0.811</b>	<b>2.03</b>	<b>5.49</b>
	50	37.65	2.64	0.811	1.83	5.48
	55	35.12	2.46	0.811	1.65	5.44

**TABLE 10D: 100 YEAR EVENT QUANTITY STORAGE REQUIREMENT - R-05**

0.0279961 =Area (ha)  
 1.00 = C

Return Period	Time (min)	Intensity (mm/hr)	Flow Q (L/s)	Allowable Runoff (L/s)	Net Flow to be Stored (L/s)	Storage Req'd (m <sup>3</sup> )
100 YEAR	60	55.89	4.35	0.920	3.43	12.35
	65	52.65	4.10	0.92	3.18	12.39
	<b>70</b>	<b>49.79</b>	<b>3.88</b>	<b>0.92</b>	<b>2.96</b>	<b>12.41</b>
	75	47.26	3.68	0.92	2.76	12.41
	80	44.99	3.50	0.92	2.58	12.39

Equations:

Flow Equation

$$Q = 2.78 \times C \times I \times A$$

Where:

C is the runoff coefficient

I is the rainfall intensity, City of Ottawa IDF

A is the total drainage area

Runoff Coefficient Equation

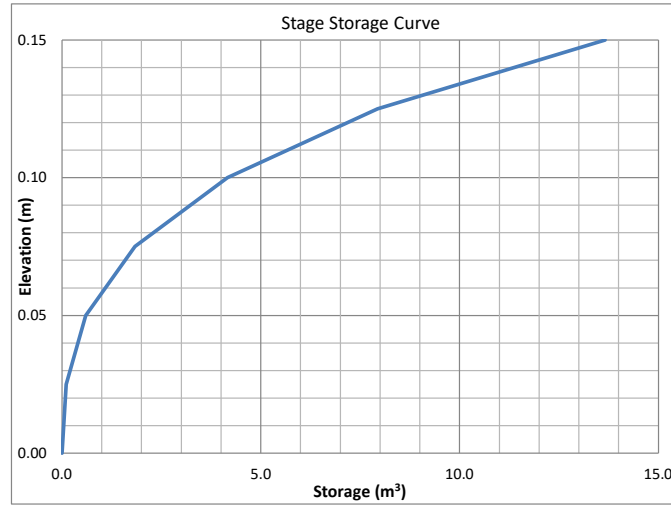
$$C_5 = (A_{\text{hard}} \times 0.9 + A_{\text{soft}} \times 0.2) / A_{\text{Tot}}$$

$$C_{100} = (A_{\text{hard}} \times 1.0 + A_{\text{soft}} \times 0.25) / A_{\text{Tot}}$$

**TABLE 10E: Storage Provided - R-04**

Area R-04: Storage Table		
Head (m)	Area* (m <sup>2</sup> )	Storage Volume (m <sup>3</sup> )
0.000	0.062	0.00
0.025	8.450	0.11
0.050	30.988	0.60
0.075	67.674	1.83
0.100	118.509	4.16
0.125	183.494	7.93
0.150	274.265	13.66

\* Area of ponding based on preliminary roof plans. Areas and storage will be updated once a mechanical engineer is retained



**Table 10F: Roof Drain Flows**

Roof Drains		
Roof Area	279.961	m <sup>2</sup>
Qty	1	
Type	Accutrol RD-100-A-ADJ	
Setting	1/4 Open	
Design Head	0.05-0.15	m
Design Flow 1" of head	0.32	L/s (ea)
Design Flow 2" of head	0.63	L/s (ea)
Design Flow 3" of head	0.71	L/s (ea)
Design Flow 4" of head	0.79	L/s (ea)
Design Flow 5" of head	0.87	L/s (ea)
Design Flow 6" of head	0.95	L/s (ea)

**Table 10G: Total Roof Storage**

Design Event	Roof Drain ID	Flow (L/S)	Head m	Required Volume
2 Year	R-04	0.768	0.095	3.69
5 Year		0.811	0.109	5.49
100 Year		0.920	0.144	12.41

**TABLE 11A: Post-Development Runoff Coefficient "C" - R-06**

Area	Surface	Ha	5 Year Event		100 Year Event	
			"C"	C <sub>avg</sub>	"C" + 25%	*C <sub>avg</sub>
Total	Hard	0.000	0.90	0.90	1.00	1.00
0.036	Roof	0.036	0.90		1.00	
	Soft	0.000	0.20		0.25	

**TABLE 11B: 2 YEAR EVENT QUANTITY STORAGE REQUIREMENT - R-06**

0.036 =Area (ha)  
 0.90 = C

Return Period	Time (min)	Intensity (mm/hr)	Flow Q (L/s)	Allowable Runoff (L/s)	Net Flow to be Stored (L/s)	Storage Req'd (m <sup>3</sup> )
2 YEAR	35	36.06	3.28	0.784	2.50	5.24
	40	32.86	2.99	0.784	2.21	5.29
	<b>45</b>	<b>30.24</b>	<b>2.75</b>	<b>0.784</b>	<b>1.97</b>	<b>5.31</b>
	50	28.04	2.55	0.784	1.77	5.30
	55	26.17	2.38	0.784	1.60	5.27

**TABLE 11C: 5 YEAR EVENT QUANTITY STORAGE REQUIREMENT - R-06**

0.0363611 =Area (ha)  
 0.90 = C

Return Period	Time (min)	Intensity (mm/hr)	Flow Q (L/s)	Allowable Runoff (L/s)	Net Flow to be Stored (L/s)	Storage Req'd (m <sup>3</sup> )
5 YEAR	45	40.63	3.70	0.827	2.87	7.75
	50	37.65	3.43	0.827	2.60	7.80
	<b>55</b>	<b>35.12</b>	<b>3.20</b>	<b>0.827</b>	<b>2.37</b>	<b>7.82</b>
	60	32.94	3.00	0.827	2.17	7.81
	65	31.04	2.82	0.827	2.00	7.79

**TABLE 11D: 100 YEAR EVENT QUANTITY STORAGE REQUIREMENT - R-06**

0.0363611 =Area (ha)  
 1.00 = C

Return Period	Time (min)	Intensity (mm/hr)	Flow Q (L/s)	Allowable Runoff (L/s)	Net Flow to be Stored (L/s)	Storage Req'd (m <sup>3</sup> )
100 YEAR	80	44.99	4.55	0.946	3.60	17.29
	85	42.95	4.34	0.95	3.40	17.32
	<b>90</b>	<b>41.11</b>	<b>4.16</b>	<b>0.95</b>	<b>3.21</b>	<b>17.33</b>
	95	39.43	3.99	0.95	3.04	17.33
	100	37.90	3.83	0.95	2.88	17.31

Equations:

Flow Equation

$$Q = 2.78 \times C \times I \times A$$

Where:

C is the runoff coefficient

I is the rainfall intensity, City of Ottawa IDF

A is the total drainage area

Runoff Coefficient Equation

$$C_s = (A_{\text{hard}} \times 0.9 + A_{\text{soft}} \times 0.2) / A_{\text{Tot}}$$

$$C_{100} = (A_{\text{hard}} \times 1.0 + A_{\text{soft}} \times 0.25) / A_{\text{Tot}}$$

**TABLE 10E: Storage Provided - R-06**

Area R-04: Storage Table		
Head (m)	Area* (m <sup>2</sup> )	Storage Volume (m <sup>3</sup> )
0.000	0.062	0.00
0.025	10.468	0.13
0.050	38.807	0.75
0.075	85.080	2.30
0.100	149.287	5.23
0.125	231.428	9.98
0.150	356.960	17.34

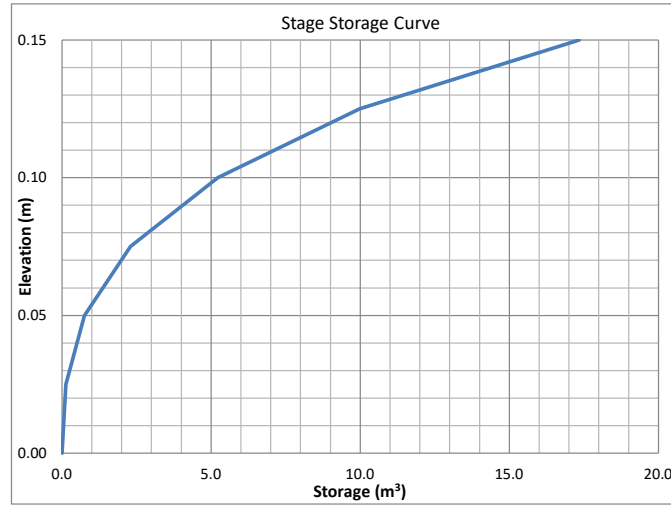
\* Area of ponding based on preliminary roof plans. Areas and storage will be updated once a mechanical engineer is retained

**Table 10F: Roof Drain Flows**

Roof Drains		
Roof Area	363.611	m <sup>2</sup>
Qty	1	
Type	Accutrol RD-100-A-ADJ	
Setting	1/4 Open	
Design Head	0.05-0.15	m
Design Flow 1" of head	0.32	L/s (ea)
Design Flow 2" of head	0.63	L/s (ea)
Design Flow 3" of head	0.71	L/s (ea)
Design Flow 4" of head	0.79	L/s (ea)
Design Flow 5" of head	0.87	L/s (ea)
Design Flow 6" of head	0.95	L/s (ea)

**Table 10G: Total Roof Storage**

Design Event	Roof Drain ID	Flow (L/S)	Head m	Required Volume
2 Year	R-04	0.784	0.100	5.31
5 Year		0.827	0.114	7.82
100 Year		0.914	0.150	17.33



**TABLE 11A: Post-Development Runoff Coefficient "C" - R-07**

Area	Surface	Ha	5 Year Event		100 Year Event	
			"C"	C <sub>avg</sub>	"C" + 25%	*C <sub>avg</sub>
Total	Hard	0.000	0.90	0.90	1.00	1.00
0.038	Roof	0.038	0.90		1.00	
	Soft	0.000	0.20		0.25	

**TABLE 11B: 2 YEAR EVENT QUANTITY STORAGE REQUIREMENT - R-07**

0.038 =Area (ha)  
 0.90 = C

Return Period	Time (min)	Intensity (mm/hr)	Flow Q (L/s)	Allowable Runoff (L/s)	Net Flow to be Stored (L/s)	Storage Req'd (m <sup>3</sup> )
2 YEAR	25	45.17	4.35	1.089	3.26	4.89
	30	40.04	3.86	1.089	2.77	4.98
	<b>35</b>	<b>36.06</b>	<b>3.47</b>	<b>1.089</b>	<b>2.38</b>	<b>5.00</b>
	40	32.86	3.16	1.089	2.08	4.98
	45	30.24	2.91	1.089	1.82	4.92

**TABLE 11C: 5 YEAR EVENT QUANTITY STORAGE REQUIREMENT - R-07**

0.0384864 =Area (ha)  
 0.90 = C

Return Period	Time (min)	Intensity (mm/hr)	Flow Q (L/s)	Allowable Runoff (L/s)	Net Flow to be Stored (L/s)	Storage Req'd (m <sup>3</sup> )
5 YEAR	30	53.93	5.19	1.210	3.98	7.17
	35	48.52	4.67	1.210	3.46	7.27
	<b>40</b>	<b>44.18</b>	<b>4.25</b>	<b>1.210</b>	<b>3.04</b>	<b>7.31</b>
	45	40.63	3.91	1.210	2.70	7.30
	50	37.65	3.63	1.210	2.42	7.25

**TABLE 11D: 100 YEAR EVENT QUANTITY STORAGE REQUIREMENT - R-07**

0.0384864 =Area (ha)  
 1.00 = C

Return Period	Time (min)	Intensity (mm/hr)	Flow Q (L/s)	Allowable Runoff (L/s)	Net Flow to be Stored (L/s)	Storage Req'd (m <sup>3</sup> )
100 YEAR	50	63.95	6.84	1.536	5.31	15.92
	55	59.62	6.38	1.54	4.84	15.98
	<b>60</b>	<b>55.89</b>	<b>5.98</b>	<b>1.54</b>	<b>4.44</b>	<b>16.00</b>
	65	52.65	5.63	1.54	4.10	15.98
	70	49.79	5.33	1.54	3.79	15.92

Equations:

Flow Equation

$$Q = 2.78 \times C \times I \times A$$

Where:

C is the runoff coefficient

I is the rainfall intensity, City of Ottawa IDF

A is the total drainage area

Runoff Coefficient Equation

$$C_s = (A_{\text{hard}} \times 0.9 + A_{\text{soft}} \times 0.2) / A_{\text{Tot}}$$

$$C_{100} = (A_{\text{hard}} \times 1.0 + A_{\text{soft}} \times 0.25) / A_{\text{Tot}}$$

**TABLE 11E: Storage Provided - R-07**

Area R-04: Storage Table		
Head (m)	Area* (m <sup>2</sup> )	Storage Volume (m <sup>3</sup> )
0.000	0.062	0.00
0.025	10.038	0.13
0.050	37.110	0.72
0.075	81.279	2.20
0.100	142.545	4.99
0.125	220.907	9.54
0.150	341.123	16.56

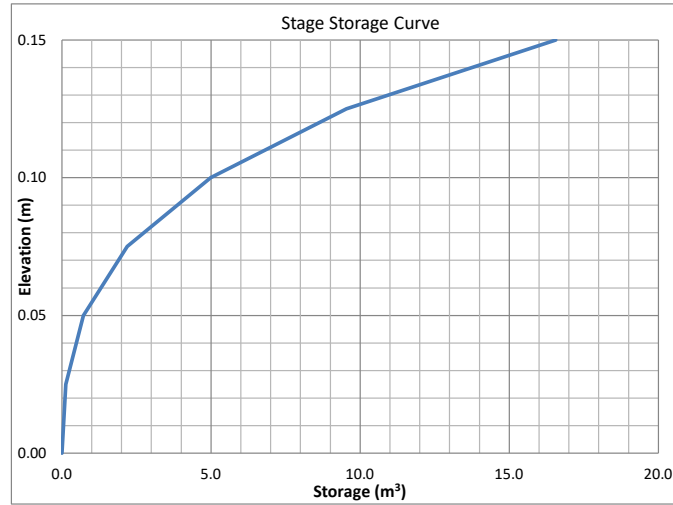
\* Area of ponding based on preliminary roof plans. Areas and storage will be updated once a mechanical engineer is retained

**Table 11F: Roof Drain Flows**

Roof Drains		
Roof Area	384.864	m <sup>2</sup>
Qty	1	
Type	Accutrol RD-100-A-ADJ	
Setting	3/4 Open	
Design Head	0.05-0.15	m
Design Flow 1" of head	0.32	L/s (ea)
Design Flow 2" of head	0.63	L/s (ea)
Design Flow 3" of head	0.87	L/s (ea)
Design Flow 4" of head	1.10	L/s (ea)
Design Flow 5" of head	1.34	L/s (ea)
Design Flow 6" of head	1.58	L/s (ea)

**Table 11G: Total Roof Storage**

Design Event	Roof Drain ID	Flow (L/S)	Head m	Required Volume
2 Year	R-04	1.089	0.100	5.00
5 Year		1.210	0.113	7.31
100 Year		1.536	0.148	16.00





**TABLE 12A: Post-Development Runoff Coefficient "C" - R-05**

Area	Surface	Ha	5 Year Event		100 Year Event	
			"C"	C <sub>avg</sub>	"C" + 25%	*C <sub>avg</sub>
Total	Hard	0.000	0.90	0.90	1.00	1.00
0.009	Roof	0.009	0.90		1.00	
	Soft	0.000	0.20		0.25	

**TABLE 12B: 2 YEAR EVENT QUANTITY STORAGE REQUIREMENT - R-05**

0.009 =Area (ha)  
 0.90 = C

Return Period	Time (min)	Intensity (mm/hr)	Flow Q (L/s)	Allowable Runoff (L/s)	Net Flow to be Stored (L/s)	Storage Req'd (m <sup>3</sup> )
2 YEAR	5	103.57	2.34	0.706	1.64	0.49
	10	76.81	1.74	0.706	1.03	0.62
	<b>15</b>	<b>61.77</b>	<b>1.40</b>	<b>0.706</b>	<b>0.69</b>	<b>0.62</b>
	20	52.03	1.18	0.706	0.47	0.57
	25	45.17	1.02	0.706	0.32	0.47

**TABLE 12C: 5 YEAR EVENT QUANTITY STORAGE REQUIREMENT - R-05**

0.0090454 =Area (ha)  
 0.90 = C

Return Period	Time (min)	Intensity (mm/hr)	Flow Q (L/s)	Allowable Runoff (L/s)	Net Flow to be Stored (L/s)	Storage Req'd (m <sup>3</sup> )
5 YEAR	5	141.18	3.20	0.749	2.45	0.73
	10	104.19	2.36	0.749	1.61	0.97
	<b>15</b>	<b>83.56</b>	<b>1.89</b>	<b>0.749</b>	<b>1.14</b>	<b>1.03</b>
	20	70.25	1.59	0.749	0.84	1.01
	25	60.90	1.38	0.749	0.63	0.94

**TABLE 12D: 100 YEAR EVENT QUANTITY STORAGE REQUIREMENT - R-05**

0.0090454 =Area (ha)  
 1.00 = C

Return Period	Time (min)	Intensity (mm/hr)	Flow Q (L/s)	Allowable Runoff (L/s)	Net Flow to be Stored (L/s)	Storage Req'd (m <sup>3</sup> )
100 YEAR	15	142.89	3.59	0.864	2.73	2.46
	20	119.95	3.02	0.86	2.15	2.58
	<b>25</b>	<b>103.85</b>	<b>2.61</b>	<b>0.86</b>	<b>1.75</b>	<b>2.62</b>
	30	91.87	2.31	0.86	1.45	2.60
	35	82.58	2.08	0.86	1.21	2.55

Equations:

Flow Equation

$$Q = 2.78 \times C \times I \times A$$

Where:

C is the runoff coefficient

I is the rainfall intensity, City of Ottawa IDF

A is the total drainage area

Runoff Coefficient Equation

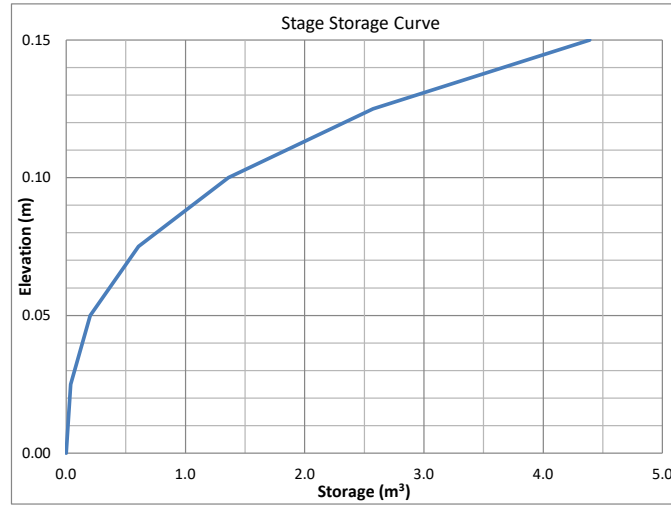
$$C_5 = (A_{\text{hard}} \times 0.9 + A_{\text{soft}} \times 0.2) / A_{\text{Tot}}$$

$$C_{100} = (A_{\text{hard}} \times 1.0 + A_{\text{soft}} \times 0.25) / A_{\text{Tot}}$$

**TABLE 12E: Storage Provided - R-08**

Area R-04: Storage Table		
Head (m)	Area* (m <sup>2</sup> )	Storage Volume (m <sup>3</sup> )
0.000	0.062	0.00
0.025	2.949	0.04
0.050	10.271	0.20
0.075	22.030	0.61
0.100	38.226	1.36
0.125	58.857	2.57
0.150	86.354	4.39

\* Area of ponding based on preliminary roof plans. Areas and storage will be updated once a mechanical engineer is retained



**Table 12F: Roof Drain Flows**

Roof Drains		
Roof Area	90.454	m <sup>2</sup>
Qty	1	
Type	Accutrol RD-100-A-ADJ	
Setting	1/4 Open	
Design Head	0.05-0.15	m
Design Flow 1" of head	0.315	L/s (ea)
Design Flow 2" of head	0.631	L/s (ea)
Design Flow 3" of head	0.710	L/s (ea)
Design Flow 4" of head	0.789	L/s (ea)
Design Flow 5" of head	0.868	L/s (ea)
Design Flow 6" of head	0.946	L/s (ea)

**Table 12G: Total Roof Storage**

Design Event	Roof Drain ID	Flow (L/S)	Head m	Required Volume
2 Year	R-04	0.706	0.075	0.62
5 Year		0.749	0.089	1.03
100 Year		0.864	0.126	2.62

**TABLE 13A: Post-Development Runoff Coefficient "C" - A-02**

Area	Surface	Ha	5 Year Event		100 Year Event	
			"C"	C <sub>avg</sub>	"C" + 25%	*C <sub>avg</sub>
Total	Hard	0.046	0.90	0.76	1.00	0.85
0.058	Roof	0.000	0.90		1.00	
	Soft	0.012	0.20		0.25	

**TABLE 13B: 2 YEAR EVENT QUANTITY STORAGE REQUIREMENT - A-02**

0.058 =Area (ha)  
 0.76 = C

Return Period	Time (min)	Intensity (mm/hr)	Flow Q (L/s)	Allowable Runoff (L/s)	Net Flow to be Stored (L/s)	Storage Req'd (m <sup>3</sup> )
2 YEAR	-5	632.75	77.67	6.3	71.37	-21.41
	0	167.22	20.53	6.3	14.23	0.00
	<b>5</b>	<b>103.57</b>	<b>12.71</b>	<b>6.3</b>	<b>6.41</b>	<b>1.92</b>
	10	76.81	9.43	6.3	3.13	1.88
	15	61.77	7.58	6.3	1.28	1.15

**TABLE 13C: 5 YEAR EVENT QUANTITY STORAGE REQUIREMENT - A-02**

0.0583086 =Area (ha)  
 0.76 = C

Return Period	Time (min)	Intensity (mm/hr)	Flow Q (L/s)	Allowable Runoff (L/s)	Net Flow to be Stored (L/s)	Storage Req'd (m <sup>3</sup> )
5 YEAR	0	230.48	28.29	6.850	21.44	0.00
	5	141.18	17.33	6.850	10.48	3.14
	<b>10</b>	<b>104.19</b>	<b>12.79</b>	<b>6.850</b>	<b>5.94</b>	<b>3.56</b>
	15	83.56	10.26	6.850	3.41	3.07
	20	70.25	8.62	6.850	1.77	2.13

**TABLE 13D: 100 YEAR EVENT QUANTITY STORAGE REQUIREMENT - A-02**

0.0583086 =Area (ha)  
 0.85 = C

Return Period	Time (min)	Intensity (mm/hr)	Flow Q (L/s)	Allowable Runoff (L/s)	Net Flow to be Stored (L/s)	Storage Req'd (m <sup>3</sup> )
100 YEAR	5	242.70	33.33	7.000	26.33	7.90
	10	178.56	24.52	7.00	17.52	10.51
	<b>15</b>	<b>142.89</b>	<b>19.62</b>	<b>7.00</b>	<b>12.62</b>	<b>11.36</b>
	20	119.95	16.47	7.00	9.47	11.36
	25	103.85	14.26	7.00	7.26	10.89

**TABLE 13E: 100 YEAR + 20% EVENT QUANTITY STORAGE REQUIREMENT - A-02**

0.058 =Area (ha)  
 0.85 = C

Return Period	Time (min)	Intensity (mm/hr)	Flow Q (L/s)	Allowable Runoff (L/s)	Net Flow to be Stored (L/s)	Storage Req'd (m <sup>3</sup> )
100 YEAR + 20%	10	214.27	29.42	7.1	22.32	13.39
	15	171.47	23.54	7.1	16.44	14.80
	<b>20</b>	<b>143.94</b>	<b>19.76</b>	<b>7.1</b>	<b>12.66</b>	<b>15.20</b>
	25	124.62	17.11	7.1	10.01	15.02
	30	110.24	15.14	7.1	8.04	14.47

Equations:

Flow Equation

$$Q = 2.78 \times C \times I \times A$$

Where:

C is the runoff coefficient

I is the rainfall intensity, City of Ottawa IDF

A is the total drainage area

Runoff Coefficient Equation

$$C_5 = (A_{\text{hard}} \times 0.9 + A_{\text{soft}} \times 0.2) / A_{\text{Tot}}$$

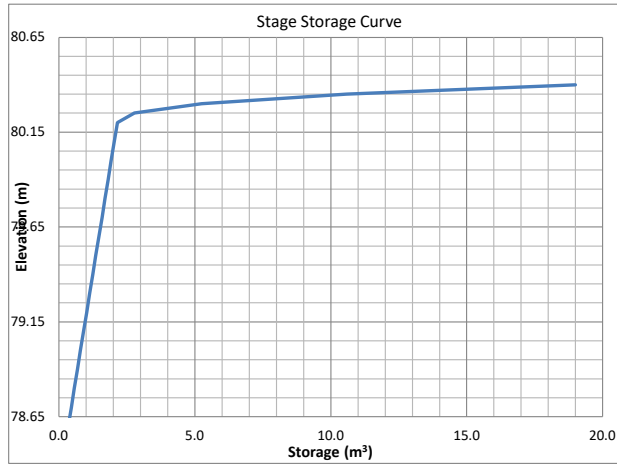
$$C_{100} = (A_{\text{hard}} \times 1.0 + A_{\text{soft}} \times 0.25) / A_{\text{Tot}}$$

TABLE 13F: Storage Provided - A-02

Area a-02: Storage Table			
Head (m)	Area* (m <sup>2</sup> )	Volume (m <sup>3</sup> )	Cumulative Volume (m <sup>3</sup> )
80.200	1.000	0.00	0.00
80.250	24.247	0.63	0.63
80.300	74.356	2.47	3.10
80.350	139.029	5.33	8.43
80.400	197.639	8.42	16.85

TABLE 13G: Catchbasin

Structures	Size Dia.(mm)	Area (m <sup>2</sup> )	T/G	Inv OUT
CBMH-02	1200	1.13	80.20	78.30



Storage Table					
Elevation (m)	System Depth (m)	CBMH-02 Volume (m <sup>3</sup> )	Underground Volume (m <sup>3</sup> )*	Ponding Volume (m <sup>3</sup> )	Total Volume (m <sup>3</sup> )
78.3	0	0.00	0.00	0.00	0.00
78.400	0.1	0.11	0.11	0.00	0.11
78.500	0.2	0.23	0.23	0.00	0.23
78.600	0.3	0.34	0.34	0.00	0.34
78.700	0.4	0.45	0.45	0.00	0.45
78.800	0.5	0.57	0.57	0.00	0.57
78.900	0.6	0.68	0.68	0.00	0.68
79.000	0.70	0.79	0.79	0.00	0.79
79.100	0.80	0.90	0.90	0.00	0.90
79.200	0.90	1.02	1.02	0.00	1.02
79.300	1.00	1.13	1.13	0.00	1.13
79.400	1.10	1.24	1.24	0.00	1.24
79.500	1.20	1.36	1.36	0.00	1.36
79.600	1.30	1.47	1.47	0.00	1.47
79.700	1.40	1.58	1.58	0.00	1.58
79.800	1.50	1.70	1.70	0.00	1.70
79.900	1.60	1.81	1.81	0.00	1.81
80.000	1.70	1.92	1.92	0.00	1.92
80.100	1.80	2.04	2.04	0.00	2.04
80.200	1.90	2.15	2.15	0.00	2.15
80.250	1.95			0.63	2.78
80.300	2.00			3.10	5.25
80.350	2.05			8.43	10.58
80.400	2.10			16.85	19.00

TABLE 13H: Orifice Sizing information - A-02

Control Device Tempest LMF 75					
Design Event	Flow (L/S)	Head (m)	Elev (m)	Outlet dia. (mm)	Volume (m <sup>3</sup> )
1:2 Year	6.3	1.60	80.00	200.00	1.92
1:5 Year	6.9	1.86	80.26	200.00	3.56
1:100 Year	7.0	1.95	80.35	200.00	11.36
1:100 Year + 20%	7.1	1.97	80.37	200.00	15.20

\*\*The design Head is calculated based on the centre of the pipe

**TABLE 14A: Post-Development Runoff Coefficient "C" - A-01**

Area	Surface	Ha	5 Year Event		100 Year Event	
			"C"	C <sub>avg</sub>	"C" + 25%	*C <sub>avg</sub>
Total	Hard	0.152	0.90	0.64	1.00	0.72
0.243	Roof	0.000	0.90		1.00	
		Soft	0.091	0.20	0.25	

**TABLE 14B: 2 YEAR EVENT QUANTITY STORAGE REQUIREMENT - A-01**

0.243 =Area (ha)  
 0.64 = C

Return Period	Time (min)	Intensity (mm/hr)	Flow Q (L/s)	Allowable Runoff (L/s)*	Net Flow to be Stored (L/s)	Storage Req'd (m <sup>3</sup> )
2 YEAR	40	32.86	14.20	3.3	10.90	26.15
	45	30.24	13.06	3.3	9.76	26.36
	<b>50</b>	<b>28.04</b>	<b>12.11</b>	<b>3.3</b>	<b>8.81</b>	<b>26.44</b>
	55	26.17	11.31	3.3	8.01	26.42
	60	24.56	10.61	3.3	7.31	26.31

**TABLE 14C: 5 YEAR EVENT QUANTITY STORAGE REQUIREMENT - A-01**

0.243 =Area (ha)  
 0.64 = C

Return Period	Time (min)	Intensity (mm/hr)	Flow Q (L/s)	Allowable Runoff (L/s)*	Net Flow to be Stored (L/s)	Storage Req'd (m <sup>3</sup> )
5 YEAR	55	35.12	15.17	3.6	11.60	38.29
	60	32.94	14.23	3.6	10.66	38.38
	<b>65</b>	<b>31.04</b>	<b>13.41</b>	<b>3.6</b>	<b>9.84</b>	<b>38.38</b>
	70	29.37	12.69	3.6	9.12	38.30
	75	27.89	12.05	3.6	8.48	38.15

**TABLE 14D: 100 YEAR EVENT QUANTITY STORAGE REQUIREMENT - A-01**

0.243 =Area (ha)  
 0.72 = C

Return Period	Time (min)	Intensity (mm/hr)	Flow Q (L/s)	Allowable Runoff (L/s)*	Net Flow to be Stored (L/s)	Storage Req'd (m <sup>3</sup> )
100 YEAR	65	52.65	25.64	5.5	20.14	78.54
	70	49.79	24.25	5.5	18.75	78.74
	<b>75</b>	<b>47.26</b>	<b>23.01</b>	<b>5.5</b>	<b>17.51</b>	<b>78.81</b>
	80	44.99	21.91	5.5	16.41	78.77
	85	42.95	20.92	5.5	15.42	78.64

Equations:

Flow Equation  
 $Q = 2.78 \times C \times I \times A$

Where:

C is the runoff coefficient

I is the rainfall intensity, City of Ottawa IDF

A is the total drainage area

Runoff Coefficient Equation

$$C_5 = (A_{\text{hard}} \times 0.9 + A_{\text{soft}} \times 0.2) / A_{\text{Tot}}$$

$$C_{100} = (A_{\text{hard}} \times 1.0 + A_{\text{soft}} \times 0.25) / A_{\text{Tot}}$$

\* Allowable run-off is 50% of the actual flow to calculate the required volume as per city of Ottawa Guidelines for underground storage

TABLE 14F: Structure information - A-01

Structures	Size Dia.(mm)	Area (m <sup>2</sup> )	T/G	Bottom of Tank
Tank	-	58.53	80.64	78.02

TABLE 14G: Storage Provided - A-01

Storage Table		
Elevation (m)	System Depth (m)	Tank Volume (m <sup>3</sup> )
78.02	0.00	0.00
78.120	0.10	5.85
78.220	0.20	11.71
78.320	0.30	17.56
78.420	0.40	23.41
78.520	0.50	29.26
78.620	0.60	35.12
78.720	0.70	40.97
78.820	0.80	46.82
78.920	0.90	52.68
79.020	1.00	58.53
79.120	1.10	64.38
79.220	1.20	70.23
79.320	1.30	76.09
79.420	1.40	81.94
79.520	1.50	87.79
79.620	1.60	93.65
79.650	1.63	95.40
79.720	1.70	95.43
79.820	1.80	95.46
79.920	1.90	95.49
80.020	2.00	95.52
80.120	2.10	95.54
80.220	2.20	95.57
80.320	2.30	95.60
80.420	2.40	95.63
80.520	2.50	95.66
80.620	2.60	95.69
80.640	2.62	95.69

Top of Tank

Top of Grate

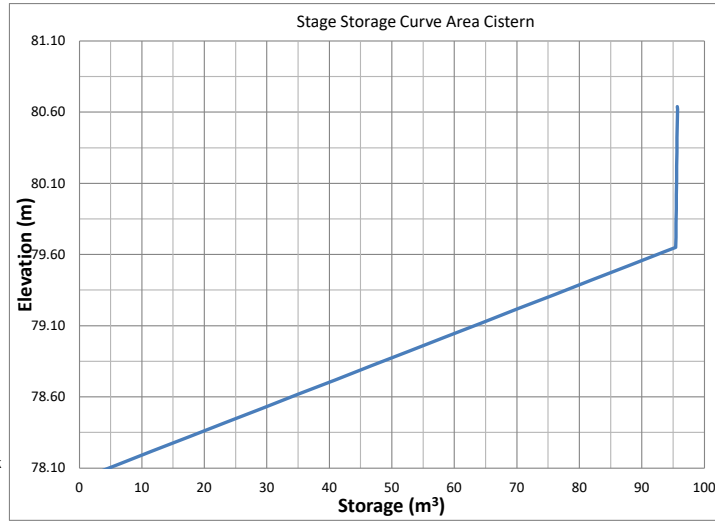


TABLE 14H: Orifice Sizing information - A-01

Control Device					
LMF 105					
Design Event	Flow (L/S)	Head (m)	Elev (m)	Outlet dia. (mm)	Volume (m <sup>3</sup> )
1:2 Year	6.6	0.45	78.47	250.00	26.44
1:5 Year	7.1	0.54	78.68	250.00	38.38
1:100 Year	11.0	1.23	79.37	250.00	78.81

\*\*The design Head is calculated based on the centre of the pipe



**Table 15: Post-Development Stormwater Management Summary**

Area ID	Area (ha)	1:5 Year Weighted Cw	1:100 Year Weighted Cw	Control Device		Outlet Location	2 Year Storm Event				5 Year Storm Event				100 Year Storm Event				
							Release (L/s)	Ponding Depth* (m)	Req'd Vol (cu.m)	Max. Vol. Provided (cu.m.)	Release (L/s)	Ponding Depth* (m)	Req'd Vol (cu.m)	Max. Vol. Provided (cu.m.)	Release (L/s)	Ponding Depth* (m)	Req'd Vol (cu.m)	Max. Vol. Provided (cu.m.)	
D-01	0.092	0.30	0.35		N/A	Navan Road	5.9	N/A	N/A	N/A	8.0	N/A	N/A	N/A	16.20	N/A	N/A	N/A	
D-02	0.006	0.20	0.25		N/A	Page Road	0.3	N/A	N/A	N/A	0.4	N/A	N/A	N/A	0.80	N/A	N/A	N/A	
D-03	0.024	0.39	0.46		N/A	Falseetto Street	2.0	N/A	N/A	N/A	2.7	N/A	N/A	N/A	5.40	N/A	N/A	N/A	
D-04	0.026	0.20	0.25		N/A	Falseetto Street	1.1	N/A	N/A	N/A	1.5	N/A	N/A	N/A	3.20	N/A	N/A	N/A	
R-01	0.013	0.90	1.00	Accutrol RD-100-A-ADJ	1/4 Open	Falseetto Street	0.73	0.08	1.16	6.24	0.78	0.10	1.82	6.24	0.89	0.13	4.43	6.24	
R-02	0.033	0.90	1.00	Accutrol RD-100-A-ADJ	3/4 Open	Falseetto Street	1.07	0.10	4.00	13.73	1.12	0.11	6.04	13.73	1.57	0.15	12.81	13.73	
R-03	0.033	0.90	1.00	Accutrol RD-100-A-ADJ	1/2 Open	Falseetto Street	0.93	0.10	4.36	14.98	1.01	0.11	6.41	14.98	1.23	0.15	14.22	14.98	
R-04	0.028	0.90	1.00	Accutrol RD-100-A-ADJ	1/4 Open	Falseetto Street	0.77	0.10	3.69	13.66	0.81	0.11	5.49	13.66	0.92	0.14	12.41	13.66	
R-05	0.028	0.90	1.00	Accutrol RD-100-A-ADJ	1/4 Open	Falseetto Street	0.77	0.10	3.69	13.66	0.81	0.11	5.49	13.66	0.92	0.14	12.41	13.66	
R-06	0.036	0.90	1.00	Accutrol RD-100-A-ADJ	1/4 Open	Falseetto Street	0.78	0.10	5.31	17.34	0.83	0.11	7.82	17.34	0.91	0.15	17.33	17.34	
R-07	0.038	0.90	1.00	Accutrol RD-100-A-ADJ	3/4 Open	Falseetto Street	1.09	0.10	5.00	16.56	1.21	0.11	7.31	16.56	1.54	0.15	16.00	16.56	
R-08	0.009	0.90	1.00	Accutrol RD-100-A-ADJ	1/4 Open	Falseetto Street	0.71	0.08	0.62	4.39	0.75	0.09	1.03	4.39	0.86	0.13	2.62	4.39	
A-02	0.058	0.76	0.85	Tempest LMF 75		Falseetto Street	6.30	1.600	1.92	19.00	6.85	1.860	3.56	19.00	7.00	1.952	11.36	19.00	
Cistern	0.243	0.64	0.72	LMF 105		Falseetto Street	6.60	0.450	26.44	95.69	7.14	0.535	38.38	95.69	11.00	1.225	78.81	95.69	
<b>Post-Development Flow</b>							<b>29.0</b>	<b>-</b>			<b>33.9</b>	<b>-</b>			<b>52.4</b>	<b>-</b>	<b>182.4</b>		
<b>Total Allowable Release Rate</b>							<b>56.9</b>				<b>56.9</b>				<b>56.9</b>				

\* Ponding depth is measured from the control device

Note Roof storage and flows are based on preliminary roof plans. Areas and storage will be updated once a mechanical engineer is retained, and final drawings are prepared.

# Volume III: TEMPEST INLET CONTROL DEVICES

Municipal Technical  
Manual Series



SECOND EDITION

LMF (Low to Medium Flow) ICD

HF (High Flow) ICD

MHF (Medium to High Flow) ICD



**IPEX**

by aliaxis

# IPEX Tempest™ Inlet Control Devices

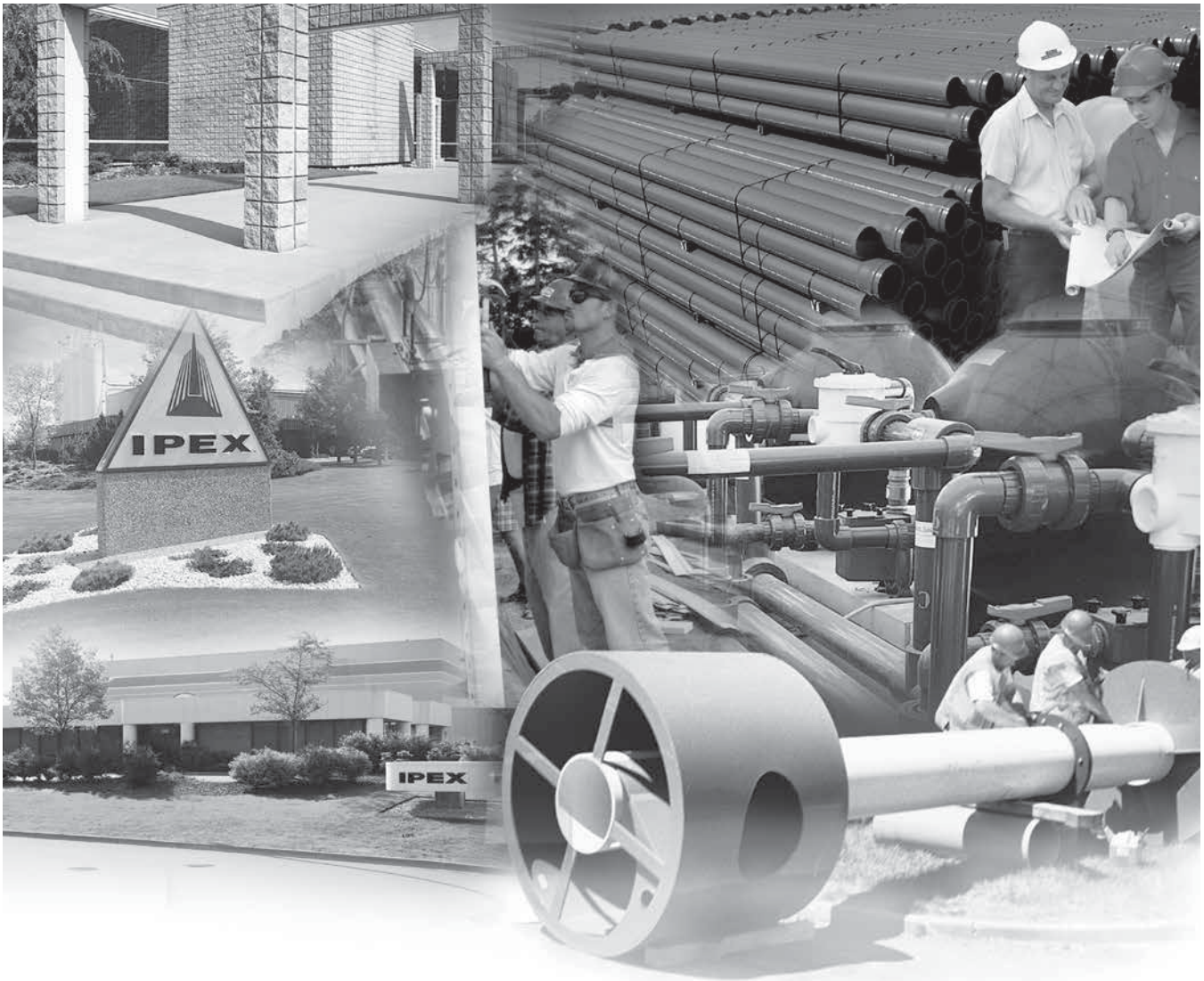
Municipal Technical Manual Series

Vol. I, 2nd Edition

© 2022 by IPEX. All rights reserved. No part of this book may be used or reproduced in any manner whatsoever without prior written permission.

For information contact: IPEX, Marketing,  
1425 North Service Road East, Oakville, Ontario, Canada, L6H 1A7

The information contained here within is based on current information and product design at the time of publication and is subject to change without notification. IPEX does not guarantee or warranty the accuracy, suitability for particular applications, or results to be obtained therefrom.



## ABOUT IPEX

At IPEX, we have been manufacturing non-metallic pipe and fittings since 1951. We formulate our own compounds and maintain strict quality control during production. Our products are made available for customers thanks to a network of regional stocking locations throughout North America. We offer a wide variety of systems including complete lines of piping, fittings, valves and custom-fabricated items.

More importantly, we are committed to meeting our customers' needs. As a leader in the plastic piping industry, IPEX continually develops new products, modernizes manufacturing facilities and acquires innovative process technology. In addition, our staff take pride in their work, making available to customers their extensive thermoplastic knowledge and field experience. IPEX personnel are committed to improving the safety, reliability and performance of thermoplastic materials. We are involved in several standards committees and are members of and/or comply with the organizations listed on this page.

For specific details about any IPEX product, contact our customer service department.

---

# CONTENTS

## TEMPEST INLET CONTROL DEVICES Technical Manual

### About IPEX

<b>Section One:</b>	<b>Product Information: TEMPEST Low, Medium Flow (LMF) ICD</b>	
	Purpose .....	4
	Product Description .....	4
	Product Function .....	4
	Product Construction .....	4
	Product Applications .....	4
	Chart 1: LMF 14 Preset Flow Curves .....	5
	Chart 2: LMF Flow Vs. ICD Alternatives .....	5
	<b>Product Installation</b>	
	Instructions to assemble a TEMPEST LMF ICD into a square catch basin: .....	6
	Instructions to assemble a TEMPEST LMF ICD into a round catch basin: .....	6
	<b>Product Technical Specification</b>	
	General .....	7
	Materials .....	7
	Dimensioning .....	7
	Installation .....	7
<b>Section Two:</b>	<b>Product Information: TEMPEST High Flow (HF) &amp; Medium, High Flow (MHF) ICD</b>	
	Product Description .....	8
	Product Function .....	8
	Product Construction .....	8
	Product Applications .....	8
	Chart 3: HF & MHF Preset Flow Curves .....	9
	<b>Product Installation</b>	
	Instructions to assemble a TEMPEST HF or MHF ICD into a square catch basin: .....	10
	Instructions to assemble a TEMPEST HF or MHF ICD into a round catch basin: .....	10
	Instructions to assemble a TEMPEST HF Sump into a square or round catch basin: ...	11
	<b>Product Technical Specification</b>	
	General .....	11
	Materials .....	11
	Dimensioning .....	11
	Installation .....	11



**PRODUCT INFORMATION: TEMPEST LOW, MEDIUM FLOW (LMF) ICD**

**Purpose**

To control the amount of storm water runoff entering a sewer system by allowing a specified flow volume out of a catch basin or manhole at a specified head. This approach conserves pipe capacity so that catch basins downstream do not become uncontrollably surcharged, which can lead to basement floods, flash floods and combined sewer overflows.

**Product Description**

Our LMF ICD is designed to accommodate catch basins or manholes with sewer outlet pipes 6" in diameter and larger. Any storm sewer larger than 12" may require custom modification. However, IPEX can custom build a TEMPEST device to accommodate virtually any storm sewer size.

Available in 14 preset flow curves, the LMF ICD has the ability to provide flow rates: 2lps – 17lps (31gpm – 270gpm)

**Product Function**

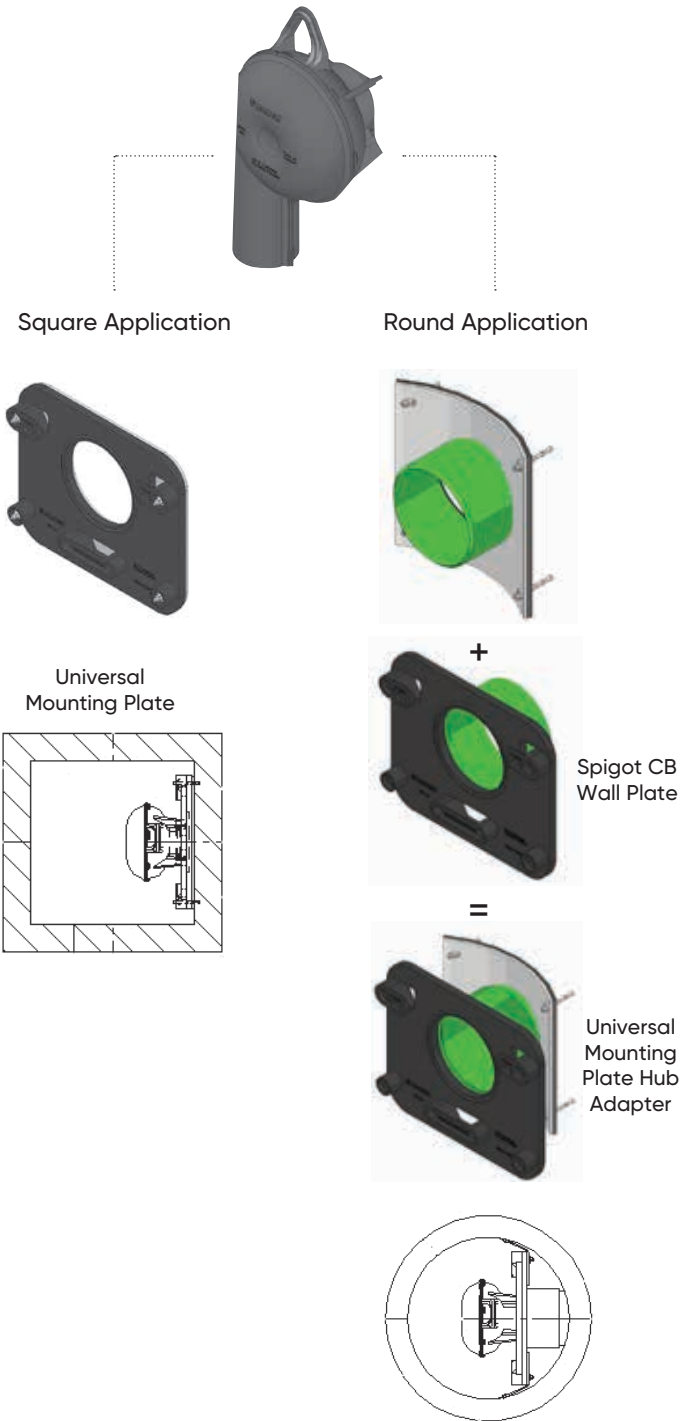
The LMF ICD vortex flow action allows the LMF ICD to provide a narrower flow curve using a larger orifice than a conventional orifice plate ICD, making it less likely to clog. When comparing flows at the same head level, the LMF ICD has the ability to restrict more flow than a conventional ICD during a rain event, preserving greater sewer capacity.

**Product Construction**

Constructed from durable PVC, the LMF ICD is light weight 8.9 Kg (19.7 lbs).

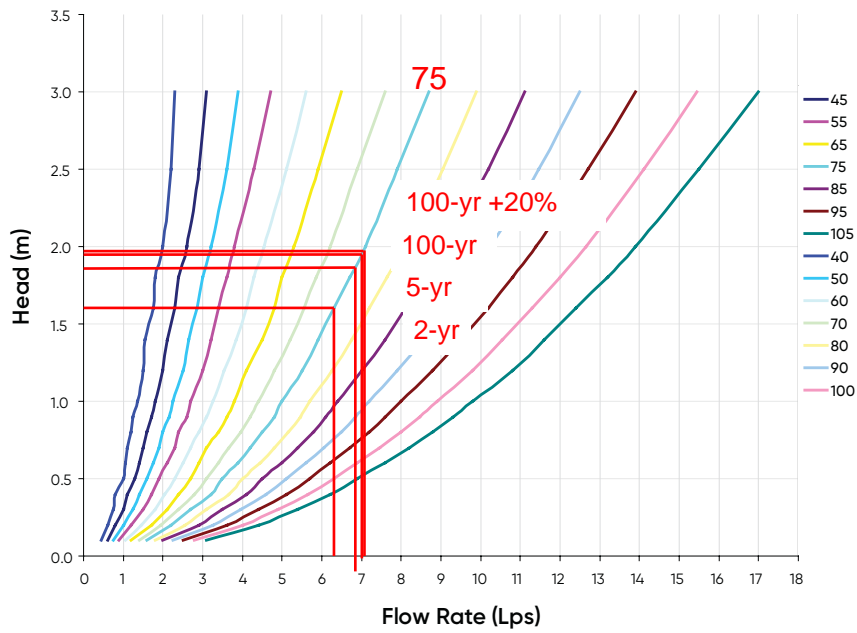
**Product Applications**

Will accommodate both square and round applications:

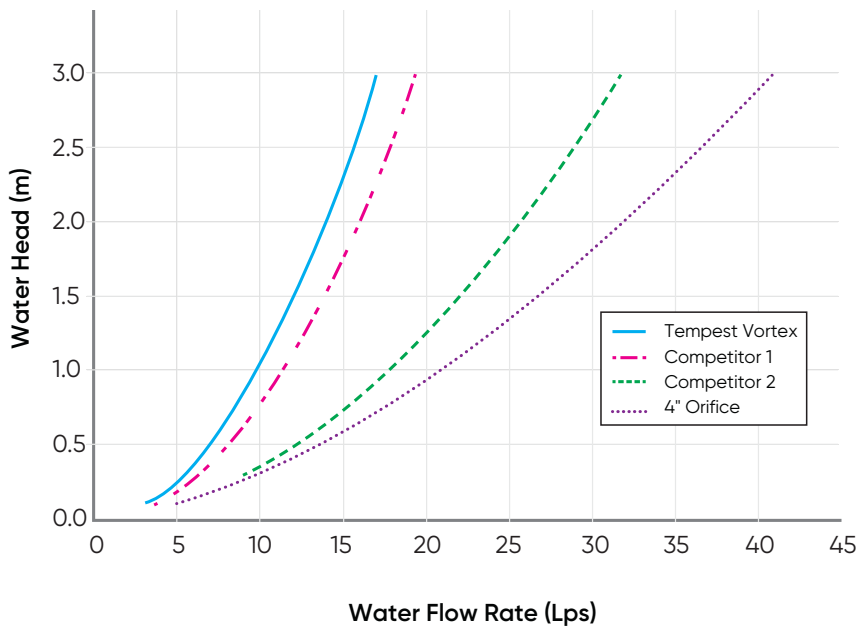




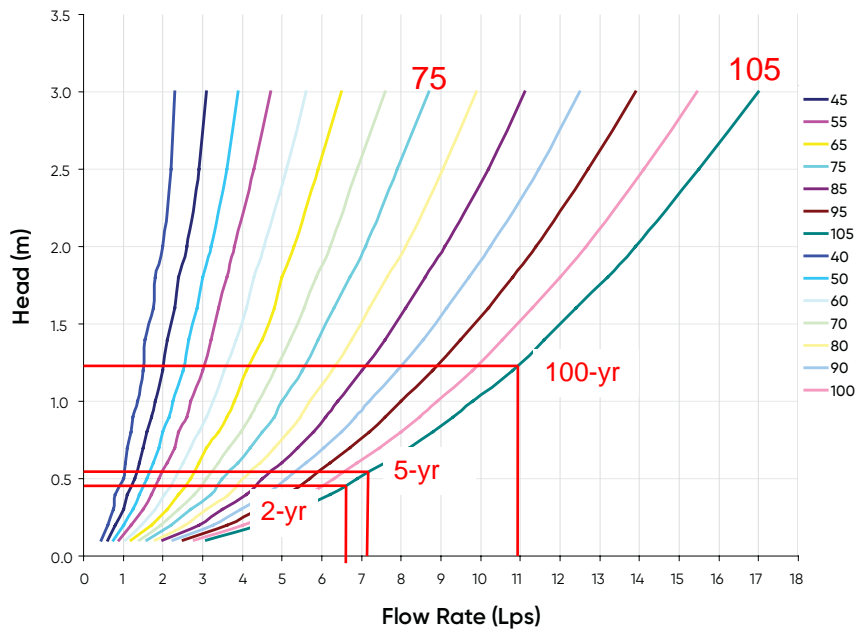
**Chart 1: LMF 14 Preset Flow Curves AREA A-02**



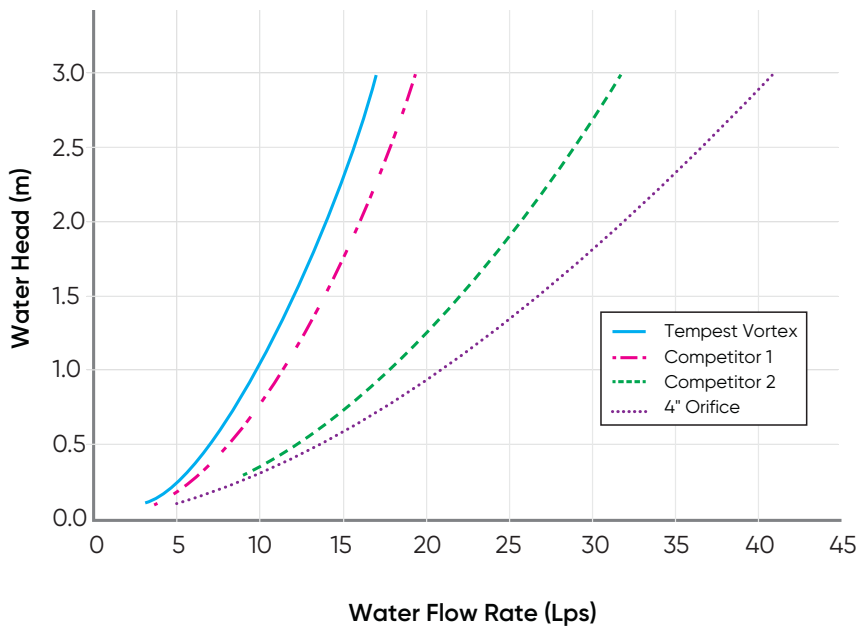
**Chart 2: LMF Flow vs. ICD Alternatives**



**Chart 1: LMF 14 Preset Flow Curves CISTERN**



**Chart 2: LMF Flow vs. ICD Alternatives**



## PRODUCT INSTALLATION

### Instructions to assemble a TEMPEST LMF ICD into a Square Catch Basin:

#### STEPS:

1. Materials and tooling verification:
  - Tooling: impact drill, 3/8" concrete bit, torque wrench for 9/16" nut, hand hammer, level, and marker.
  - Material: (4) concrete anchor 3/8 x 3-1/2, (4) washers, (4) nuts, universal mounting plate, ICD device.
2. Use the mounting wall plate to locate and mark the hole (4) pattern on the catch basin wall. You should use a level to ensure that the plate is at the horizontal.
3. Use an impact drill with a 3/8" concrete bit to make the four holes at a minimum of 1-1/2" depth up to 2-1/2". Clean the concrete dust from the holes.
4. Install the anchors (4) in the holes by using a hammer. Thread the nuts on the top of the anchors to protect the threads when you hit the anchors with the hammer. Remove the nuts from the ends of the anchors.
5. Install the universal mounting plate on the anchors and screw the 4 nuts in place with a maximum torque of 40 N.m (30 lbf-ft). There should be no gap between the wall mounting plate and the catch basin wall.
6. From the ground above using a reach bar, lower the ICD device by hooking the end of the reach bar to the handle of the ICD device. Align the triangular plate portion into the mounting wall plate. Push down the device to be sure it has centered in to the universal mounting plate and has created a seal.



#### WARNING

- Verify that the outlet pipe doesn't protrude into the catch basin. If it does, cut down the pipe flush to the catch basin wall.
- Call your IPEX representative for more information or if you have any questions about our products.

### Instructions to assemble a TEMPEST LMF ICD into a Round Catch Basin:

#### STEPS:

1. Materials and tooling verification.
  - Tooling: impact drill, 3/8" concrete bit, torque wrench for 9/16" nut, hand hammer, level and marker.
  - Material: (4) concrete anchor 3/8 x 3-1/2, (4) washers and (4) nuts, spigot CB wall plate, universal mounting plate hub adapter, ICD device.
2. Use the spigot catch basin wall plate to locate and mark the hole (4) pattern on the catch basin wall. You should use a level to ensure that the plate is at the horizontal.
3. Use an impact drill with a 3/8" concrete bit to make the four holes at a depth between 1-1/2" to 2-1/2". Clean the concrete dust from the holes.
4. Install the anchors (4) in the holes by using a hammer. Thread the nuts on the top of the anchors to protect the threads when you hit the anchors with the hammer. Remove the nuts from the ends of the anchors.
5. Install the CB spigot wall plate on the anchors and screw the 4 nuts in place with a maximum torque of 40 N.m (30 lbf-ft). There should be no gap between the spigot wall plate and the catch basin wall.
6. Apply solvent cement on the hub of the universal mounting plate, hub adapter and the spigot of the CB wall plate, then slide the hub over the spigot. Make sure the universal mounting plate is at the horizontal and its hub is completely inserted onto the spigot. Normally, the corners of the universal mounting plate hub adapter should touch the catch basin wall.
7. From ground above using a reach bar, lower the ICD device by hooking the end of the reach bar to the handle of the ICD device. Align the triangular plate portion into the mounting wall plate. Push down the device to be sure it has centered in to the mounting plate and has created a seal.



#### WARNING

- Verify that the outlet pipe doesn't protrude into the catch basin. If it does, cut back the pipe flush to the catch basin wall.
- The solvent cement which is used in this installation is to be approved for PVC.
- The solvent cement should not be used below 0°C (32°F) or in a high humidity environment. Refer to the IPEX solvent cement guide to confirm the required curing time or visit the IPEX Online Solvent Cement Training Course available at [ipexna.com](http://ipexna.com).
- Call your IPEX representative for more information or if you have any questions about our products.

## PRODUCT TECHNICAL SPECIFICATION

### General

Inlet control devices (ICD's) are designed to provide flow control at a specified rate for a given water head level and also provide odour and floatable control. All ICD's will be IPEX Tempest or approved equal.

All devices shall be removable from a universal mounting plate. An operator from street level using only a T-bar with a hook will be able to retrieve the device while leaving the universal mounting plate secured to the catch basin wall face. The removal of the TEMPEST devices listed above must not require any unbolting or special manipulation or any special tools.

High Flow (HF) Sump devices will consist of a removable threaded cap which can be accessible from street level with out entry into the catchbasin (CB). The removal of the threaded cap shall not require any special tools other than the operator's hand.

ICD's shall have no moving parts.

### Materials

ICD's are to be manufactured from Polyvinyl Chloride (PVC) or Polyurethane material, designed to be durable enough to withstand multiple freeze-thaw cycles and exposure to harsh elements.

The inner ring seal will be manufactured using a Buna or Nitrile material with hardness between Duro 50 and Duro 70.

The wall seal is to be comprised of a 3/8" thick Neoprene Closed Cell Sponge gasket which is attached to the back of the wall plate.

All hardware will be made from 304 stainless steel.

### Dimensioning

The Low Medium Flow (LMF), High Flow (HF) and the High Flow (HF) Sump shall allow for a minimum outlet pipe diameter of 200mm with a 600mm deep Catch Basin sump.

### Installation

Contractor shall be responsible for securing, supporting and connecting the ICD's to the existing influent pipe and catchbasin/manhole structure as specified and designed by the Engineer.

## PRODUCT INFORMATION: TEMPEST HF & MHF ICD

### Product Description

Our HF, HF Sump and MHF ICD's are designed to accommodate catch basins or manholes with sewer outlet pipes 6" in diameter or larger. Any storm sewer larger than 12" may require custom modification. However, IPEX can custom build a TEMPEST device to accommodate virtually any storm sewer size.

Available in 5 preset flow curves, these ICDs have the ability to provide constant flow rates: 9lps (143 gpm) and greater

### Product Function

**TEMPEST HF (High Flow):** designed to manage moderate to higher flows 15 L/s (240 gpm) or greater and prevent the propagation of odour and floatables. With this device, the cross-sectional area of the device is larger than the orifice diameter and has been designed to limit head losses. The HF ICD can also be ordered without flow control when only odour and floatable control is required.



**TEMPEST HF (High Flow) Sump:** The height of a sewer outlet pipe in a catch basin is not always conveniently located. At times it may be located very close to the catch basin floor, not providing enough sump for one of the other TEMPEST ICDs with universal back plate to be installed. In these applications, the HF Sump is offered. The HF Sump offers the same features and benefits as the HF ICD; however, is designed to raise the outlet in a square or round catch basin structure. When installed, the HF sump is fixed in place and not easily removed. Any required service to the device is performed through a clean-out located in the top of the device which can be often accessed from ground level.



**TEMPEST MHF (Medium to High Flow):** The MHF plate or plug is designed to control flow rates 9 L/s (143 gpm) or greater. It is not designed to prevent the propagation of odour and floatables.

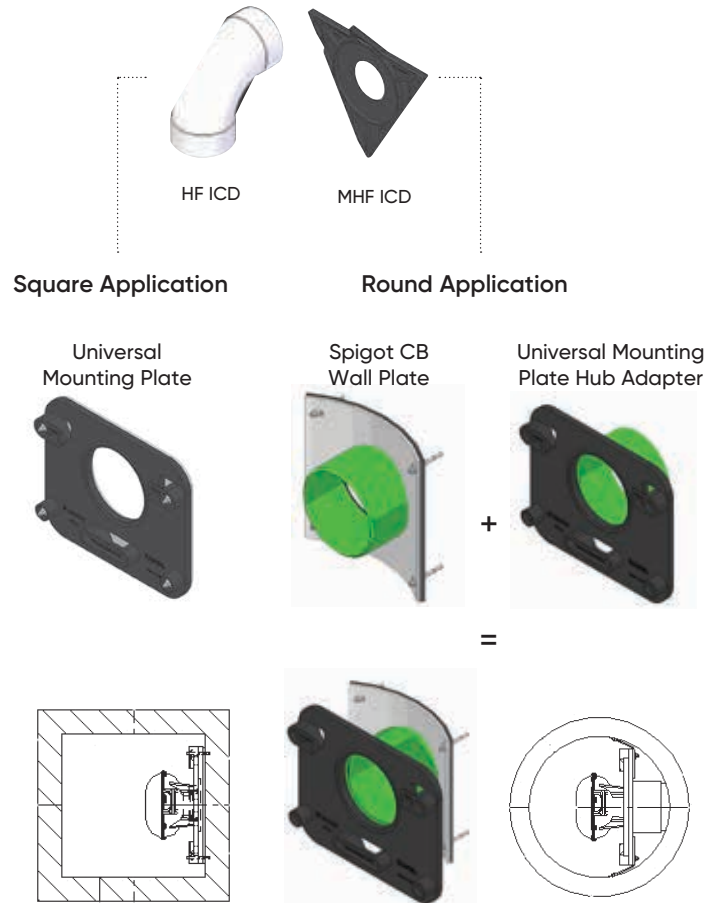


### Product Construction

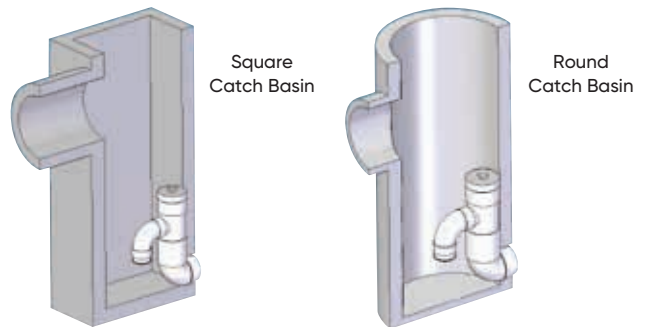
The HF, HF Sump and MHF ICDs are built to be light weight at a maximum weight of 6.8 Kg (14.6 lbs).

### Product Applications

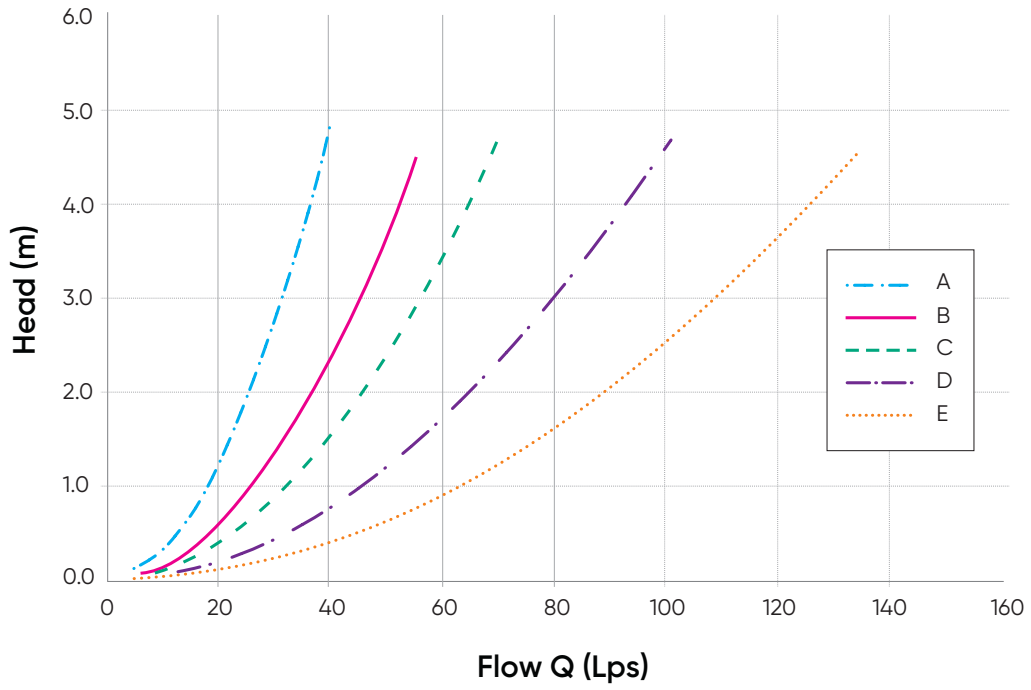
The HF and MHF ICD's are available to accommodate both square and round applications:



The HF Sump is available to accommodate low to no sump applications in both square and round catch basins:



**Chart 3: HF & MHF Preset Flow Curves**





## PRODUCT INSTALLATION

### Instructions to assemble a TEMPEST HF or MHF ICD into a Square Catch Basin:

1. Materials and tooling verification:
  - Tooling: impact drill, 3/8" concrete bit, torque wrench for 9/16" nut, hand hammer, level, and marker.
  - Material: (4) concrete anchor 3/8 x 3-1/2, (4) washers, (4) nuts, universal mounting plate, ICD device
2. Use the mounting wall plate to locate and mark the hole (4) pattern on the catch basin wall. You should use a level to ensure that the plate is at the horizontal.
3. Use an impact drill with a 3/8" concrete bit to make the four holes at a minimum of 1-1/2" depth up to 2-1/2". Clean the concrete dust from the holes.
4. Install the anchors (4) in the holes by using a hammer. Thread the nuts on the top of the anchors to protect the threads when you hit the anchors with the hammer. Remove the nuts from the ends of the anchors.
5. Install the universal wall mounting plate on the anchors and screw the 4 nuts in place with a maximum torque of 40 N.m (30 lbf-ft). There should be no gap between the wall mounting plate and the catch basin wall.
6. From the ground above using a reach bar, lower the device by hooking the end of the reach bar to the handle of the ICD device. Align the triangular plate portion into the mounting wall plate. Push down the device to be sure it has centered in to the universal wall mounting plate and has created a seal.

#### WARNING

- Verify that the outlet pipe doesn't protrude into the catch basin. If it does, cut down the pipe flush to the catch basin wall.
- Call your IPEX representative for more information or if you have any questions about our products.

### Instructions to assemble a TEMPEST HF or MHF ICD into a Round Catch Basin:

#### STEPS:

1. Materials and tooling verification.
  - Tooling: impact drill, 3/8" concrete bit, torque wrench for 9/16" nut, hand hammer, level and marker.
  - Material: (4) concrete anchor 3/8 x 3-1/2, (4) washers and (4) nuts, spigot CB wall plate, universal mounting plate hub adapter, ICD device.
2. Use the round catch basin spigot adaptor to locate and mark the hole (4) pattern on the catch basin wall. You should use a level to ensure that the plate is at the horizontal.
3. Use an impact drill with a 3/8" concrete bit to make the four holes at a depth between 1-1/2" to 2-1/2". Clean the concrete dust from the holes.
4. Install the anchors (4) in the holes by using a hammer. Thread the nuts on the top of the anchors to protect the threads when you hit the anchors with the hammer. Remove the nuts from the ends of the anchors.
5. Install the spigot CB wall plate on the anchors and screw the 4 nuts in place with a maximum torque of 40 N.m (30 lbf-ft). There should be no gap between the spigot CB wall plate and the catch basin wall.
6. Put solvent cement on the hub of the universal mounting plate, hub adapter and the spigot of the CB wall plate, then slide the hub over the spigot. Make sure the universal mounting plate is at the horizontal and its hub is completely inserted onto the spigot. Normally, the corners of the hub adapter should touch the catch basin wall.
7. From ground above using a reach bar, lower the device by hooking the end of the reach bar to the handle of the ICD device. Align the triangular plate portion into the mounting wall plate. Push down the device to be sure it has centered in to the wall mounting plate and has created a seal.

#### WARNING

- Verify that the outlet pipe doesn't protrude into the catch basin. If it does, cut down the pipe flush to the catch basin wall.
- The solvent cement which is used in this installation is to be approved for PVC.
- The solvent cement should not be used below 0°C (32°F) or in a high humidity environment. Refer to the IPEX solvent cement guide to confirm the required curing time or visit the IPEX Online Solvent Cement Training Course available at [www.ipexinc.com](http://www.ipexinc.com).
- Call your IPEX representative for more information or if you have any questions about our products.

## Instructions to assemble a TEMPEST HF Sump into a Square or Round Catch Basin:

### STEPS:

1. Materials and tooling verification:
  - Tooling: impact drill, 3/8" concrete bit, torque wrench for 9/16" nut, hand hammer, level, mastic tape and metal strapping
  - Material: (2) concrete anchor 3/8 x 3-1/2, (2) washers, (2) nuts, HF Sump pieces (2).
2. Apply solvent cement to the spigot end of the top half of the sump. Apply solvent cement to the hub of the bottom half of the sump. Insert the spigot of the top half of the sump into the hub of the bottom half of the sump.
3. Install the 8" spigot of the device into the outlet pipe. Use the mastic tape to seal the device spigot into the outlet pipe. You should use a level to be sure that the fitting is standing at the vertical.
4. Use an impact drill with a 3/8" concrete bit to make a series of 2 holes along each side of the body throat. The depth of the hole should be between 1-1/2" to 2-1/2". Clean the concrete dust from the 2 holes.
5. Install the anchors (2) in the holes by using a hammer. Put the nuts on the top of the anchors to protect the threads when you hit the anchors. Remove the nuts from the ends of the anchors.
6. Cut the metal strapping to length and connect each end of the strapping to the anchors. Screw the nuts in place with a maximum torque of 40 N.m (30 lbf-ft). The device should be completely flush with the catch basin wall.



### WARNING

- Verify that the outlet pipe doesn't protrude into the catch basin. If it does, cut down the pipe flush to the catch basin wall.
- The solvent cement which is used in this installation is to be approved for PVC.
- The solvent cement should not be used below 0°C (32°F) or in a high humidity environment. Refer to the IPEX solvent cement guide to confirm the required curing time or visit the IPEX Online Solvent Cement Training Course available at [www.ipexinc.com](http://www.ipexinc.com).
- Call your IPEX representative for more information or if you have any questions about our products.

## PRODUCT TECHNICAL SPECIFICATION

### General

Inlet control devices (ICD's) are designed to provide flow control at a specified rate for a given water head level and also provide odour and floatable control where specified. All ICD's will be IPEX Tempest or approved equal.

All devices shall be removable from a universal mounting plate. An operator from street level using only a T-bar with a hook shall be able to retrieve the device while leaving the universal mounting plate secured to the catch basin wall face. The removal of the TEMPEST devices listed above shall not require any unbolting or special manipulation or any special tools.

High Flow (HF) Sump devices shall consist of a removable threaded cap which can be accessible from street level with out entry into the catchbasin (CB). The removal of the threaded cap shall not require any special tools other than the operator's hand.

ICD's shall have no moving parts.

### Materials

ICD's are to be manufactured from Polyvinyl Chloride (PVC) or Polyurethane material, designed to be durable enough to withstand multiple freeze-thaw cycles and exposure to harsh elements.

The inner ring seal will be manufactured using a Buna or Nitrile material with hardness between Duro 50 and Duro 70.

The wall seal is to be comprised of a 3/8" thick Neoprene Closed Cell Sponge gasket which is attached to the back of the wall plate.

All hardware will be made from 304 stainless steel.

### Dimensioning

The Low Medium Flow (LMF), High Flow (HF) and the High Flow (HF) Sump shall allow for a minimum outlet pipe diameter of 200mm with a 600mm deep Catch Basin sump.

### Installation

Contractor shall be responsible for securing, supporting and connecting the ICD's to the existing influent pipe and catchbasin/manhole structure as specified and designed by the Engineer.

---

NOTES

# SALES AND CUSTOMER SERVICE

IPEX Inc.

Toll Free: (866) 473-9462

[ipexna.com](http://ipexna.com)

## About the IPEX Group of Companies

As leading suppliers of thermoplastic piping systems, the IPEX Group of Companies provides our customers with some of the largest and most comprehensive product lines. All IPEX products are backed by more than 50 years of experience. With state-of-the-art manufacturing facilities and distribution centers across North America, we have established a reputation for product innovation, quality, end-user focus and performance.

Markets served by IPEX group products are:

- Electrical systems
- Telecommunications and utility piping systems
- PVC, CPVC, PP, ABS, PEX, FR-PVDF and PE pipe and fittings (1/4" to 48")
- Industrial process piping systems
- Municipal pressure and gravity piping systems
- Plumbing and mechanical piping systems
- PE Electrofusion systems for gas and water
- Industrial, plumbing and electrical cements
- Irrigation systems

Products manufactured by IPEX Inc.

Tempest™ is a trademark of IPEX Branding Inc.

This literature is published in good faith and is believed to be reliable. However it does not represent and/or warrant in any manner the information and suggestions contained in this brochure. Data presented is the result of laboratory tests and field experience.

A policy of ongoing product improvement is maintained. This may result in modifications of features and/or specifications without notice.



Name	Invert Elevation (m)	Rim Elevation	Max. HGL 100-yr	Max. HGL Stress Test	Footing Level, USF	Freeboard (Footing – 100-yr HGL) (m)	Freeboard (Footing – stress test HGL) (m)
		(m)	(m)	(m)	(m)		
MH_16	71.05	76.43	71.83	71.83	N/A	N/A	N/A
MH_17	76.88	80.68	76.94	76.94	78.70	1.76	1.76
MH_18	72.43	77.09	72.63	72.63	75.80	3.17	3.17
MH_19	71.83	75.63	72.19	72.19	74.25	2.06	2.06
MH_2	77.55	80.73	77.55	77.55	78.50	0.95	0.95
MH_20	71.23	75.39	71.74	71.74	73.35	1.61	1.61
MH_21	70.68	74.97	71.22	71.22	73.35	2.13	2.13
MH_21B	69.96	73.40	70.9	70.90	N/A	N/A	N/A
MH_3	76.03	79.28	76.13	76.13	77.10	0.97	0.97
MH_3-1	76.16	79.23	77.18	77.24	N/A	N/A	N/A
MH_4	74.59	78.10	74.69	74.69	75.50	0.81	0.81
MH_5	72.73	77.05	73.03	73.04	74.85	1.82	1.81
<b>MH_6</b>	<b>77.42</b>	<b>80.32</b>	<b>77.60</b>	<b>77.60</b>	<b>78.40</b>	<b>0.80</b>	<b>0.80</b>
MH_7	76.66	80.14	76.81	76.81	78.05	1.24	1.24
MH_8	75.55	79.11	75.73	75.73	77.05	1.32	1.32
MH_9	71.86	75.70	72.25	72.26	73.90	1.65	1.64
MH90	69.54	71.44	70.83	70.83	N/A	N/A	N/A

As the preceding table shows, in all locations the proposed HGL is at least 0.80 m below the USF elevations within the subject lands.

In summary, the proposed major and minor systems within the subject site are capable of safely conveying the post-development flows. It was also determined that the existing major system downstream of the Ziegler Street outfall from the subject site also has adequate capacity to convey the post-development major flows. Please refer to **Appendix B** for the detailed digital model files

Urbantech confirms that the modelling methodologies are consistent with the current edition of the City of Ottawa Design Guideline (and any subsequent Technical Bulletins and takes responsibility for overall model correctness and results. JF Sabourin & Associates have also completed a peer review of the dual drainage model for the subject site and have concluded that the revised design approach taken meets the SWM objectives for the subject site.

### 4.3.3 Block 64

Block 64 is proposed to have an R5 zoning which supports a variety of uses including mid-rise apartment buildings. Based on the zoning provisions set out in the Ottawa Zoning By-law 2008-250 Consolidation, 30% of the lot area must be provided as landscaped area for a lot containing a mid rise apartment. Based on the above, an average runoff coefficient of 0.72 (equivalent to 70% imperviousness) shall be assumed for the developed condition of this block.

Since the block will provide 100-year on-site capture and the proposed runoff coefficient (0.72) is greater than the target (0.30), on-site quantity control will be required. A preliminary estimate based on controlling the 100-year to target release rate of 85 L/s/ha (modelled as 74 L/s) indicates that approximately 291 m<sup>3</sup> of on-site storage volume would be required. Actual storage volume configuration is to be determined through Site Plan Control.

The above demonstrates that Block 64 can adequately provide the necessary on-site storage volume (~291 m<sup>3</sup>) and quantity control to support the target release rates upon development. This storage target may be refined through the Site Plan Control process, but the proposed drainage plan for the site plan block should be tested / verified with the dual-drainage model for the subject lands.

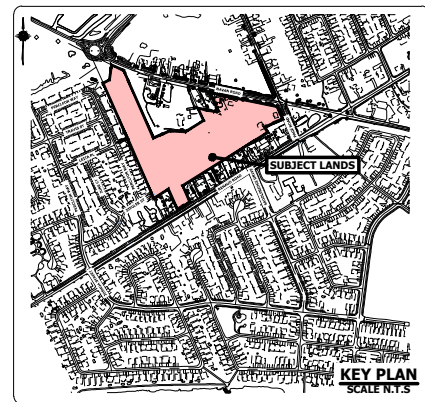
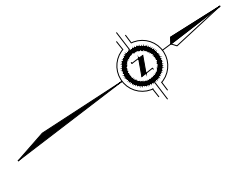
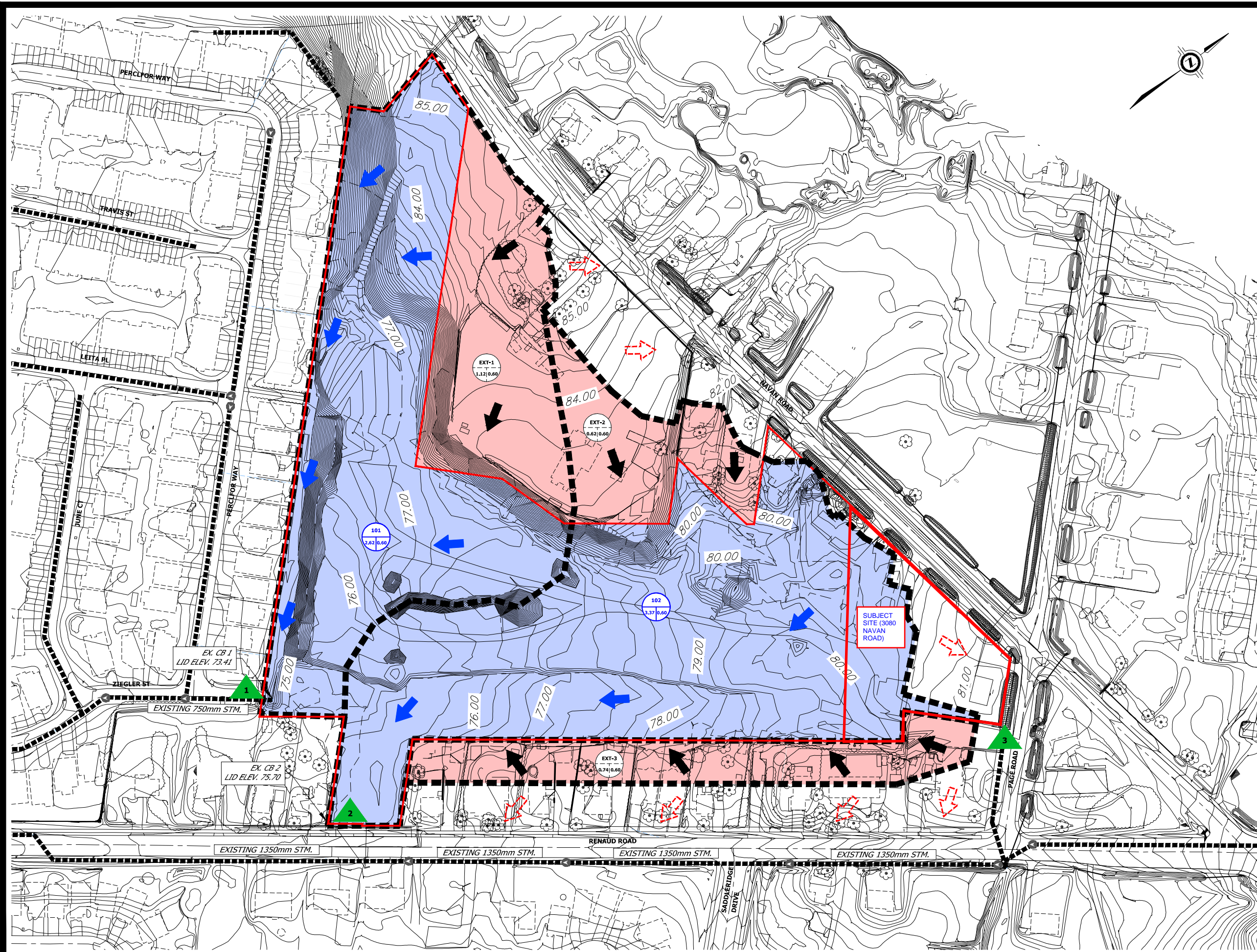
It should be noted that until Block 64 is developed, a temporary ICD (Type IPEX D) will be required at manhole CTRL1 under interim conditions in order to control the existing Block 64 area to the target flow of 85 L/s/ha, as per the ICD sizing calculations provided in **Appendix B**.

### 4.3.4 Erosion & Quality Control

Erosion and water quality control is provided by Pond 3 which was designed assuming a 55% imperviousness drainage area. As noted in **Table 4-1** in **Section 4.3.1**, the combined drainage catchment for the subject site and external area to the north is 55% impervious.

According to the Pond 3 design details (Stantec, 2005), the required permanent pool of 10,887m<sup>3</sup> was based on assuming 55% imperviousness for the subject lands and the provided permanent pool was 18,986m<sup>3</sup>. There is more than sufficient quality control volume in the pond to manage the drainage from the subject lands. Therefore, no additional measures are required. As noted in the April 2021 FSR, the subject lands are not suitable for application of LID measures.





**LEGEND**

- SUBJECT PROPERTY
- EXISTING CONTOUR
- INTERNAL DRAINAGE AREA ID
- INTERNAL DRAINAGE AREA (ha)
- RUNOFF COEFFICIENT
- EXTERNAL DRAINAGE AREA ID
- EXTERNAL DRAINAGE AREA (ha)
- RUNOFF COEFFICIENT
- ▲ DRAINAGE OUTLET & ID
- EXISTING DRAINAGE BOUNDARY
- EXISTING INTERNAL DRAINAGE AREA
- EXISTING EXTERNAL DRAINAGE AREA FLOWING TOWARDS SITE
- ➔ EXISTING INTERNAL FLOW DIRECTION
- ➔ EXISTING EXTERNAL FLOW DIRECTION
- ➔ EXISTING FLOW DIRECTION FLOWING AWAY FROM SITE
- EXISTING STORM SEWER AND FLOW DIRECTION

**Urbantech® Consulting**  
 A Division of Leighton-Zec Ltd.  
 3750 14th Avenue, Suite 301,  
 Markham, ON, L3R 3T7  
 TEL 905.946.9461 • urbantech.com

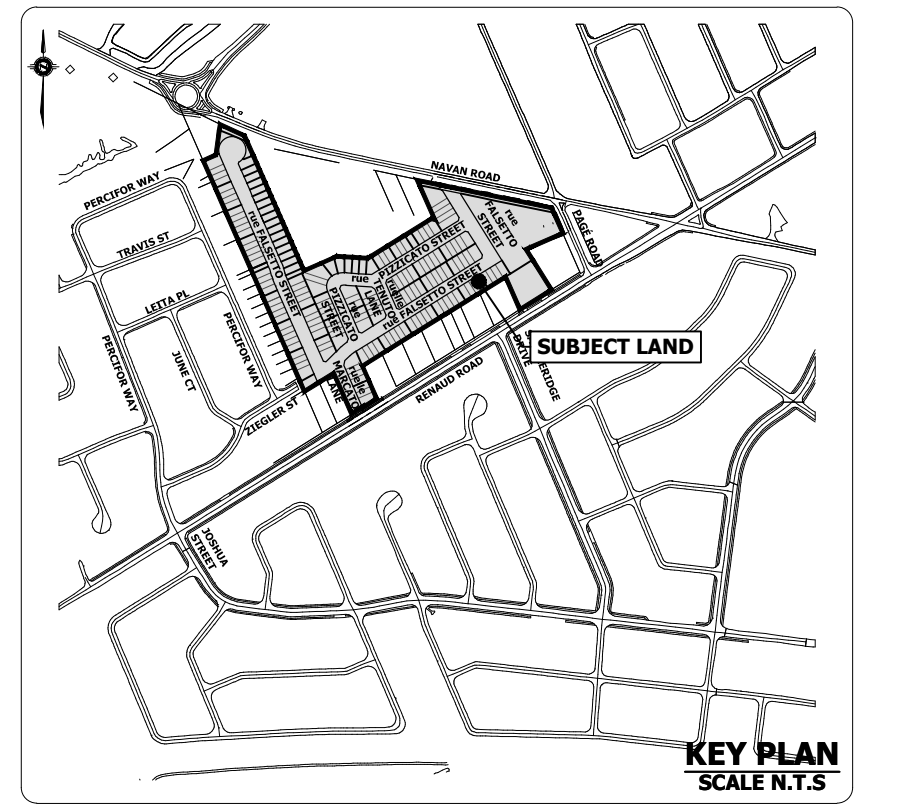
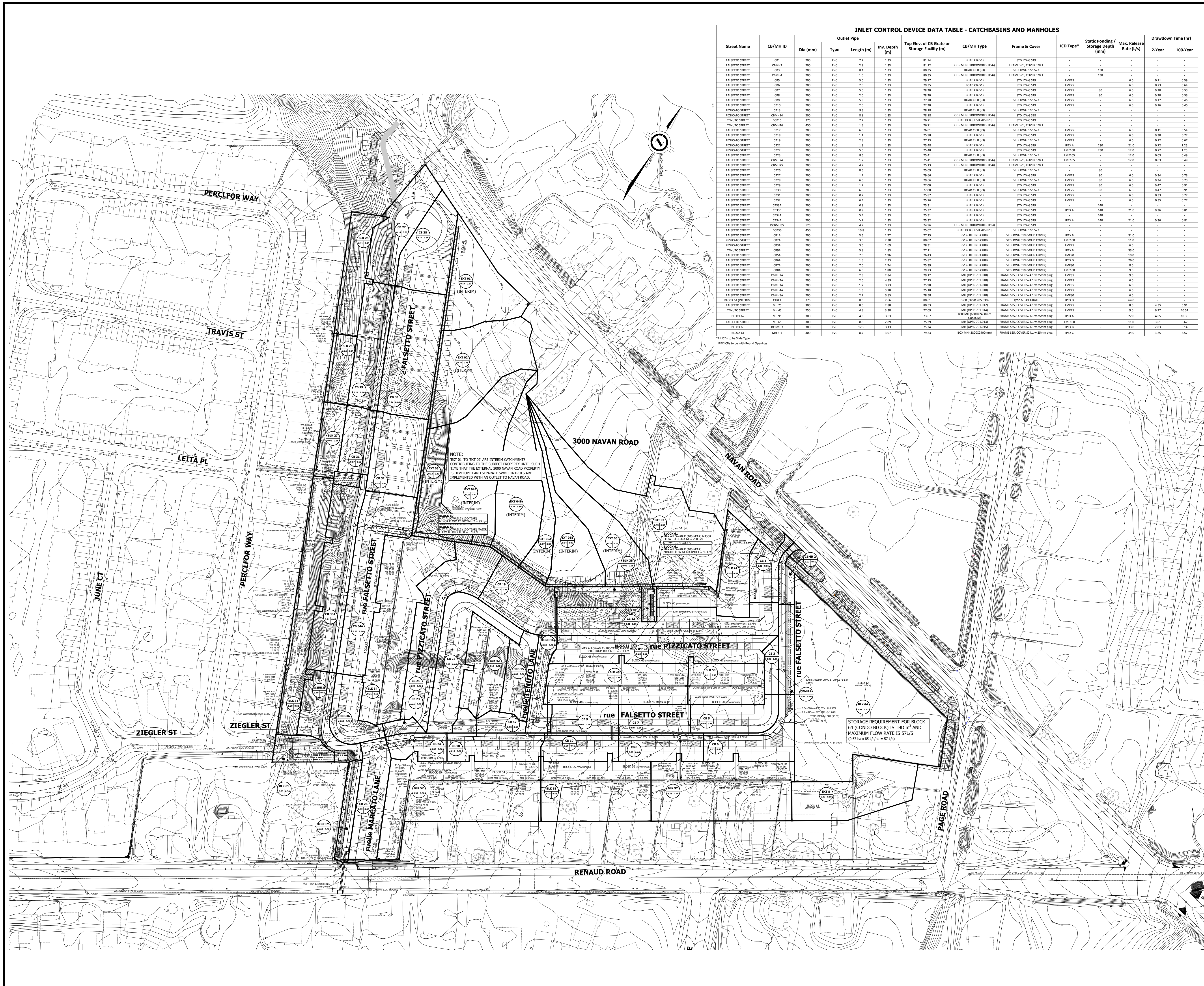
**Caivan Renaud Inc.**  
 CITY OF OTTAWA

PRE-DEVELOPMENT  
 DRAINAGE PLAN

PROJECT No.	DATE	SCALE	FIGURE No.
20-647-O	APR 2021	1:2000	<b>3</b>

File: T:\Projects\20-647-O\_Caivan - Brazeau East\Reports\Final\Functional Servicing Report\Drawings & Figures\20-647-O-STM-2\_Existing Storm Drainage Plan.dwg - Revised by <RBAGHER> : Tue, Aug 11, 2020 - 9:43am





**INLET CONTROL DEVICE DATA TABLE - CATCHBASINS AND MANHOLES**

Street Name	CB/MH ID	Outlet Pipe			Top Elev. of CB Grate or Storage Facility (m)	CB/MH Type	Frame & Cover	ICD Type*	Static Ponding / Storage Depth (mm)	Max. Release Rate (L/s)	Drawdown Time (hr)	
		Dia (mm)	Type	Length (m)							2-Year	100-Year
FALSETTO STREET	CB1	200	PVC	7.2	81.34	ROAD CB (S1)	STD. DWS 519	-	-	-	-	-
FALSETTO STREET	CBM02	200	PVC	2.9	81.12	OGS MH (HYDROWORKS 1648)	FRAME S25, COVER 128.1	-	-	-	-	-
FALSETTO STREET	CB3	200	PVC	8.1	81.33	ROAD CCB (S3)	STD. DWS 522, S23	-	150	-	-	-
FALSETTO STREET	CBM04	200	PVC	3.0	80.35	OGS MH (HYDROWORKS 1648)	FRAME S25, COVER 128.1	-	-	-	-	-
FALSETTO STREET	CB4	200	PVC	5.0	79.57	ROAD CB (S1)	STD. DWS 519	LMP75	-	6.0	0.31	0.59
FALSETTO STREET	CB5	200	PVC	2.0	79.35	ROAD CB (S1)	STD. DWS 519	LMP75	-	6.0	0.23	0.44
FALSETTO STREET	CB7	200	PVC	5.0	79.20	ROAD CB (S1)	STD. DWS 519	LMP75	80	6.0	0.20	0.33
FALSETTO STREET	CB8	200	PVC	2.0	79.20	ROAD CB (S1)	STD. DWS 519	LMP75	80	6.0	0.20	0.33
FALSETTO STREET	CB9	200	PVC	5.8	77.28	ROAD CCB (S3)	STD. DWS 522, S23	LMP75	-	6.0	0.17	0.46
FALSETTO STREET	CB10	200	PVC	2.0	77.20	ROAD CB (S1)	STD. DWS 519	LMP75	-	6.0	0.18	0.45
FALSETTO STREET	CB11	200	PVC	5.9	79.18	ROAD CCB (S3)	STD. DWS 522, S23	LMP75	-	-	-	-
FALSETTO STREET	CBM14	200	PVC	8.8	79.18	OGS MH (HYDROWORKS 1648)	STD. DWS 528	-	-	-	-	-
FALSETTO STREET	CB15	375	PVC	7.7	79.71	ROAD CCB (S3)	STD. DWS 528	-	-	-	-	-
FALSETTO STREET	CBM16	450	PVC	1.3	79.71	OGS MH (HYDROWORKS 1648)	FRAME S25, COVER 128.1	-	-	-	-	-
FALSETTO STREET	CB17	200	PVC	6.6	79.61	ROAD CCB (S3)	STD. DWS 522, S23	LMP75	-	6.0	0.11	0.54
FALSETTO STREET	CB18	200	PVC	1.1	79.98	ROAD CB (S1)	STD. DWS 519	LMP75	-	6.0	0.38	0.72
FALSETTO STREET	CB19	200	PVC	2.8	77.23	ROAD CCB (S3)	STD. DWS 522, S23	LMP75	-	6.0	0.22	0.67
FALSETTO STREET	CB21	200	PVC	1.3	79.48	ROAD CB (S1)	STD. DWS 519	IPXA 1	230	23.0	0.72	1.25
FALSETTO STREET	CB22	200	PVC	5.6	79.48	ROAD CB (S1)	STD. DWS 519	LMP100	230	12.0	0.72	1.25
FALSETTO STREET	CB23	200	PVC	8.5	79.41	ROAD CCB (S3)	STD. DWS 522, S23	LMP100	-	12.0	0.03	0.49
FALSETTO STREET	CBM08	200	PVC	3.3	79.41	OGS MH (HYDROWORKS 1648)	FRAME S25, COVER 128.1	LMP100	-	-	-	-
FALSETTO STREET	CBM05	200	PVC	4.2	79.13	OGS MH (HYDROWORKS 1648)	STD. DWS 528	LMP100	-	12.0	0.03	0.49
FALSETTO STREET	CB20	200	PVC	8.6	79.29	ROAD CCB (S3)	STD. DWS 522, S23	LMP75	80	6.0	0.34	0.73
FALSETTO STREET	CB27	200	PVC	1.2	79.66	ROAD CB (S1)	STD. DWS 519	LMP75	80	6.0	0.34	0.73
FALSETTO STREET	CB28	200	PVC	6.0	79.66	ROAD CCB (S3)	STD. DWS 522, S23	LMP75	80	6.0	0.34	0.73
FALSETTO STREET	CB29	200	PVC	1.2	79.60	ROAD CB (S1)	STD. DWS 519	LMP75	80	6.0	0.47	0.91
FALSETTO STREET	CB30	200	PVC	6.0	79.60	ROAD CCB (S3)	STD. DWS 522, S23	LMP75	80	6.0	0.47	0.91
FALSETTO STREET	CB31	200	PVC	0.2	79.87	ROAD CB (S1)	STD. DWS 519	LMP75	-	6.0	0.33	0.72
FALSETTO STREET	CB37	200	PVC	6.4	79.76	ROAD CB (S1)	STD. DWS 519	LMP75	-	6.0	0.35	0.77
FALSETTO STREET	CB35A	200	PVC	0.9	79.11	ROAD CB (S1)	STD. DWS 519	LMP75	140	6.0	0.35	0.77
FALSETTO STREET	CB38	200	PVC	0.9	79.32	ROAD CB (S1)	STD. DWS 519	IPXA 1	140	23.0	0.36	0.81
FALSETTO STREET	CB36A	200	PVC	5.4	79.51	ROAD CB (S1)	STD. DWS 519	LMP75	140	23.0	0.36	0.81
FALSETTO STREET	CB34B	200	PVC	5.4	79.32	ROAD CB (S1)	STD. DWS 519	IPXA 1	140	23.0	0.36	0.81
FALSETTO STREET	CBM03	325	PVC	4.7	79.95	OGS MH (HYDROWORKS 1648)	STD. DWS 519	-	-	-	-	-
FALSETTO STREET	CB32	450	PVC	28.8	79.62	ROAD CCB (S3)	STD. DWS 522, S23	-	-	-	-	-
FALSETTO STREET	CB34	200	PVC	3.5	77.25	(S1) - BERINO CURB	STD. DWS 519 (SOLID COVER)	IPXA 8	-	31.0	-	-
FALSETTO STREET	CB34A	200	PVC	3.5	80.07	(S1) - BERINO CURB	STD. DWS 519 (SOLID COVER)	LMP100	-	11.0	-	-
FALSETTO STREET	CB34B	200	PVC	3.5	79.81	(S1) - BERINO CURB	STD. DWS 519 (SOLID COVER)	LMP75	-	6.0	-	-
FALSETTO STREET	CB34C	200	PVC	5.8	77.11	(S1) - BERINO CURB	STD. DWS 519 (SOLID COVER)	IPXA 8	-	33.0	-	-
FALSETTO STREET	CB34D	200	PVC	3.0	78.41	(S1) - BERINO CURB	STD. DWS 519 (SOLID COVER)	LMP80	-	20.0	-	-
FALSETTO STREET	CB34E	200	PVC	1.3	79.82	(S1) - BERINO CURB	STD. DWS 519 (SOLID COVER)	IPXA 0	-	26.0	-	-
FALSETTO STREET	CB34F	200	PVC	7.0	79.39	(S1) - BERINO CURB	STD. DWS 519 (SOLID COVER)	LMP80	-	8.0	-	-
FALSETTO STREET	CB34G	200	PVC	6.5	79.23	(S1) - BERINO CURB	STD. DWS 519 (SOLID COVER)	LMP100	-	9.0	-	-
FALSETTO STREET	CBM01A	200	PVC	2.8	79.12	MH (OPFD 701.020)	FRAME S25, COVER 124.1 w/ 25mm phg	LMP85	-	9.0	-	-
FALSETTO STREET	CBM01B	200	PVC	2.0	77.13	MH (OPFD 701.020)	FRAME S25, COVER 124.1 w/ 25mm phg	LMP75	-	6.0	-	-
FALSETTO STREET	CBM01C	200	PVC	1.7	79.90	MH (OPFD 701.020)	FRAME S25, COVER 124.1 w/ 25mm phg	LMP85	-	6.0	-	-
FALSETTO STREET	CBM01D	200	PVC	1.3	79.18	MH (OPFD 701.020)	FRAME S25, COVER 124.1 w/ 25mm phg	LMP75	-	6.0	-	-
FALSETTO STREET	CBM01E	200	PVC	2.7	78.18	MH (OPFD 701.020)	FRAME S25, COVER 124.1 w/ 25mm phg	LMP80	-	6.0	-	-
FALSETTO STREET	CBM01F	200	PVC	6.5	80.05	DICS (OPFD 701.020)	Type A - 3" GRATE	IPXA 0	-	64.0	-	-
FALSETTO STREET	MH 25	300	PVC	8.0	80.13	MH (OPFD 701.020)	FRAME S25, COVER 124.1 w/ 25mm phg	LMP75	-	8.0	4.35	5.81
FALSETTO STREET	MH 30	300	PVC	4.8	79.98	MH (OPFD 701.020)	FRAME S25, COVER 124.1 w/ 25mm phg	LMP75	-	9.0	6.27	8.51
FALSETTO STREET	MH 35	300	PVC	4.6	79.67	BOX MH (SDOCD000000)	FRAME S25, COVER 124.1 w/ 25mm phg	IPXA 1	-	22.0	4.05	10.35
FALSETTO STREET	MH 40	300	PVC	8.5	79.39	MH (OPFD 701.020)	FRAME S25, COVER 124.1 w/ 25mm phg	LMP100	-	11.0	3.61	3.87
FALSETTO STREET	CBM01H	200	PVC	12.0	79.74	MH (OPFD 701.020)	FRAME S25, COVER 124.1 w/ 25mm phg	IPXA 8	-	39.0	2.89	1.58
FALSETTO STREET	MH 31	300	PVC	8.7	80.07	BOX MH (SDOCD000000)	FRAME S25, COVER 124.1 w/ 25mm phg	IPXA C	-	34.0	3.25	3.17

- LEGEND:**
- STORM DRAINAGE BOUNDARY
  - STORM MANHOLE
  - EXISTING STORM MANHOLE
  - STORM SERVICE CONNECTION
  - AREA ID
  - RUNOFF COEFFICIENT AREA (HA)
  - SINGLE CATCH BASIN
  - CATCH BASIN WITH WATERTIGHT COVER
  - DOUBLE CATCH BASIN
  - CATCH BASIN 'ELBOW' (S31)
  - 90° TEE CATCH BASIN
  - 3-WAY TEE CATCH BASIN
  - CATCH BASIN 'T' (S30)
  - PROPOSED OVERLAND FLOW DIRECTION
  - EXISTING OVERLAND FLOW DIRECTION

NOTE: EXT 01 TO EXT 07 ARE INTERIM CATCHMENTS CONTRIBUTING TO THE SUBJECT PROPERTY UNTIL SUCH TIME THAT THE EXISTING 3000 NAVAN ROAD PROJECT IS DEVELOPED AND SEPARATE SWM CONTROLS ARE IMPLEMENTED WITH AN OUTLET TO NAVAN ROAD.

STORAGE REQUIREMENT FOR BLOCK 64 (CONDO BLOCK) IS TBD m<sup>3</sup> AND MAXIMUM FLOW RATE IS 57 L/S (0.67 m<sup>3</sup> x 85 L/m<sup>2</sup> x 87 L/S)

**NOTES**  
 RUNOFF COEFFICIENT CALCULATIONS PROVIDED IN APPENDIX B OF THE DESIGN REPORT AND SWM BIPREPARED BY URBANTECH CONSULTING, DATED MAY 2022.

**TOPOGRAPHIC INFORMATION**  
 TOPOGRAPHIC INFORMATION PROVIDED BY J.D. BARNES LIMITED, PROJECT No. 20-10-078-00, SURVEY DATED FEBRUARY 21, 2022.

**LEGAL INFORMATION**  
 DRAFT PLAN PROVIDED BY J.D. BARNES LIMITED, PROJECT No. 20-10-078-00, DATED MAY 02, 2022.

**BENCHMARK**  
 1. ELEVATIONS ARE GEODETIC AND WERE ESTABLISHED USING GLOBAL NAVIGATION SATELLITE SYSTEMS (GNSS) EQUIPMENT TO ESTABLISH ELLIPSOIDAL HEIGHTS. ELLIPSOIDAL HEIGHTS WERE TRANSFORMED TO CGVD-1928: 78 DATUM (GEODETIC) USING THE FEDERAL HT 2.0 HEIGHT TRANSFORMATION MODEL.  
 2. IT IS THE RESPONSIBILITY OF THE USER OF THIS INFORMATION TO VERIFY THAT THE SITE BENCHMARKS HAVE NOT BEEN ALTERED OR DISTURBED AND THAT ITS RELATIVE ELEVATION AND DESCRIPTION AGREES WITH THE INFORMATION SHOWN ON THIS DRAWING.  
 3. PROJECT BENCHMARK IS A MAG NAIL SET IN HYDRO POLE HAVING AN ELEVATION OF 81.92m (REFER TO DRAWING 601).

7	SEVENTH ENGINEERING SUBMISSION	AUG. 2022	J.O.	J.O.
6	SIXTH ENGINEERING SUBMISSION	JUNE 2022	J.O.	J.O.
5	FIFTH ENGINEERING SUBMISSION	MAY 2022	J.O.	J.O.
4	FOURTH ENGINEERING SUBMISSION	FEB. 2022	J.O.	J.O.
No.	REVISIONS	DATE	BY	APP'D

**CITY OF OTTAWA**  
**CAIVAN RHYTHM SUBDIVISION**  
 (6101 Renaud Road (3060 Navan Road) & 2980, 3000, 3048, 3054 & 3080 Navan Road)

**CATCHBASIN DRAINAGE CAPTURE & ICD PLAN**

**CAIVAN COMMUNITIES**

Urbantech® Consulting  
 A Division of Leighton-Zec Ltd.  
 813-2706 Alta Vista Drive  
 Ottawa, ON, K1V 7T4  
 TEL 613.714.8626 • urbantech.com

URBANTECH®

DRAWN BY: J.M. CHECKED BY: J.O. FIGURE No.:  
 DESIGNED BY: T.L. CHECKED BY: J.O.  
 SCALE: 1:1000 DATE: AUGUST 2022

**802**