



*Stormwater Management - Grading & Drainage - Storm & Sanitary Sewers - Watermains*

700 Long Point Circle  
Ottawa, Ontario K1T 4E9

613-425-8044  
d.gray@dbgrayengineering.com

## SITE SERVICING STUDY & STORMWATER MANAGEMENT REPORT

2167 MCGEE SIDE ROAD  
OTTAWA, ONTARIO

REPORT No. 23024

JUNE 27, 2023  
REVISED AUGUST 10, 2023

# **CONTENTS**

- 1.0 INTRODUCTION**
- 2.0 WATER SERVICING**
  - 2.1 WATER SUPPLY FOR FIREFIGHTING
  - 2.2 DOMESTIC WATER SUPPLY
- 2.0 SANITARY SERVICING**
- 4.0 STORMWATER MANAGEMENT**
  - 4.1 QUALITY CONTROL
  - 4.2 QUANTITY CONTROL
- 5.0 CONCLUSIONS**

# **LIST OF APPENDICES**

- A WATER SERVICING
- B SANITARY SERVICING
- C STORMWATER MANAGEMENT & STORM SERVICING
- D CITY OF OTTAWA SERVICING STUDY CHECKLIST

## 1.0 INTRODUCTION

This Servicing Study & Stormwater Management Report is a description of the servicing for a 1,635 m<sup>3</sup> office / warehouse building and addresses the stormwater management requirements of 7,621 m<sup>3</sup> of land located at 2167 McGee Side Road, at the corner of John Cavanaugh Drive, in Ottawa. A 12 m drainage easement, 922 m<sup>2</sup> in area, located adjacent to the north property line will remain wooded and undeveloped. The remaining developable area (6,699 m<sup>2</sup>) is currently vacant with approximately 70% of the area covered with compacted granular material. (An application for Site Plan Control was previously submitted for a different proposed development on the subject property; the application was close to being approved in 2021.)

This report forms part of the stormwater management design for the proposed development. Also refer to drawings C-1 to C-7 prepared by D. B. Gray Engineering Inc.

## 2.0 WATER SERVICING

### 2.1 WATER SUPPLY FOR FIREFIGHTING

As per City of Ottawa Technical Bulletin ISTB-2021-03 the requirement for the level of fire protection on private property in rural areas is based on the Fire Underwriters Survey (FUS) method. Using the FUS method the required fire flow for the proposed building is calculated to be 9,000 L/min, and the volume is calculated to be 1,080,000 L for a 2.0 hour water supply (as per Required Duration of Fire Flow (FUS 2020 Table 1)). However, as per the Ontario Building Code (OBC) method, the required flow rate for firefighting for the proposed building is calculated to be 2,700 L/min or a 81,000 L volume for 30-minute (as required by OBC) water supply; and in the City of Ottawa, the fire department typically only requires 10,000 to 20,000 gallons ( $\pm 45,000$  to  $\pm 90,000$  L). Therefore, two 10,000 gallon (45,460 L) tanks, totaling 20,000 gallons (90,920 L) tanks are proposed. Since this meets the OBC requirements, it is expected that the Ottawa Fire Services and Ottawa Building Code Services will consider the volume of the proposed tanks an adequate water supply for firefighting. Refer to calculations in Appendix A.

### 2.2 DOMESTIC WATER SUPPLY

An existing drilled well, constructed approximately 20 m west of the southwest corner of the proposed building, will provide the domestic water supply. As stated in the Hydrogeological Assessment and Terrain Analysis, prepared by Paterson Group (File: PH4146-LET.01, dated June 2, 2021): *"The pumping test results show that TW1 [the existing well] has a high yield to support the water demands for the proposed building. ... The total volume of water pumped during the 9.5 hour pumping test was approximately 6,840 L. This is approximately 1.3 times the maximum total daily design volume of water required to support the proposed commercial development (maximum 5,150 L/day). The total daily design sewage flow (TDDSF) volume was provided by D.B. Gray Engineering ..."* (Paterson's statement was based in an earlier design; the proposed building has a lower TDDSF of 4,327 L/day. Therefore, the total volume of water pumped during the pumping test is about 1.6 times the maximum total daily design volume of water required to support the proposed commercial development.)

As concluded in the Hydrogeological Assessment and Terrain Analysis, prepared by Paterson Group (File: PH4146-LET.01, dated June 2, 2021): *"The results of the water supply assessment have provided satisfactory evidence that the water supply aquifer underlying the subject site can support the proposed commercial development from both a quality and quantity perspective. ... The preferred water supply aquifer intercepted by TW1 [the existing well] contains a water supply that is potable, and contains only elevated concentrations of hardness, TDS, and turbidity. The above noted parameters can be treated with current readily available water conditioning equipment. ... It is anticipated that further development of the onsite well will reduce turbidity levels to below 1 NTU."*

### 3.0 SANITARY SERVICING

An on-site septic system is proposed. As stated in the Hydrogeological Assessment and Terrain Analysis, prepared by Paterson Group (File: PH4146-LET.01, dated June 2, 2021): *“A total daily design sewage flow (TDDSF) of 5,150 L/day was provided by D.B. Gray Engineering ... Typical commercial developments will have lower actual loading compared to the conservative design loads as per the OBC. Based on the results of the predicted nitrate impact assessment, it is our opinion that the proposed property can adequately support the proposed commercial development without having an adverse impact on the underlying bedrock aquifer. ... The predicted nitrate concentrations at the property boundaries are predicted to be near the required 10 mg/L threshold with a standard double pass Waterloo Biofilter treatment system based on a maximum volume of 5,150 L/day. If additional denitrification is deemed necessary, a standard system such as the Waterloo Biofilter WaterNOx system would easily provide the required treatment necessary.”* (Paterson’s statement was based in an earlier design; the proposed building has a lower TDDSF of 4,327 L/day; therefore, Paterson’s conclusions should still be valid.)

The total daily design sewage flow (TDDSF) of 4,327 L/day was calculated for the proposed building in accordance with the OBC as follows:

Offices Areas:

The greater of:

36 employees x 75 L/day per employees = 2,827 L/day

or

350.5 m<sup>2</sup> of offices x 75 L/day per 9.3 m<sup>2</sup> = 2,700 L/day

Warehouse Areas:

10 loading bays = 10 x 150 l/day = 1,500 L/day

Total:

Office areas (2,827 l/day) + Warehouse Areas (1,500 L/day) = 4,327 L/day

The proposed on-site septic system will be a Class 4 system sized for a daily design sanitary sewage flow of 4,327 L/day; consisting of a minimum 12,980 L (3 x TDDSF) septic tank; a minimum 3,000 L time-dosing pump tank; two ECOFLO 650BR biofilter treatment units (each having a 2,500 L capacity – with time dosing) with an ECOFLO Denitrification Unit certified for 50% reduction in nitrates as per NSF/ANSI Standard 245); and a Type ‘A’ dispersal bed. To prevent having an adverse effect on the bacterial action in the septic system, floor drains will drain to the John Cavanaugh Drive roadside ditch via an oil interceptor. The proposed floor drains will have a sump below the outlet designed to trap sand and grit in the sump so that they do not enter the oil interceptor. The oil interceptor will be sized for design flow rate of 35 l/gpm or 132 L/min (which is almost 3 times the 12 L/min pumping rate during Paterson’s pumping test): CAPTEURS GR Model GR-5035 oil interceptor having an oil capacity of 90 litres or approved equal. Refer to Appendix B.

An application for a septic permit will be submitted to the Ottawa Septic System Office (OSSO) shortly.

### 4.0 STORMWATER MANAGEMENT

#### 4.1 QUALITY CONTROL

For the previous application, the Mississippi Valley Conservation Authority (MVCA) advised that the property is within the Carp River watershed area and that a normal water quality protection which is 70% TSS (total suspended solids) removal; and an infiltration target of 104 mm/yr are required for the site development. However, the City of Ottawa requires that 80% TSS removal be achieved. An infiltration trench located at the bottom a stormwater detention area is proposed meet these requirements.

Rainfall runoff from 90% of the developable portion of the property and virtually all of the hard surfaces (96%) will drain to the infiltration trench. As per the MOE Stormwater Management Planning and Design Manual; if an infiltration trench is being used to treat stormwater runoff from roads and parking lots, pre-treatment is necessary to minimize the potential for suspended sediments to clog the trench; and sand filters, vegetated filter strips, grassed swales and/or oil/grit separators may be used. Over 90% of the hard surfaces draining to the stormwater detention area will drain to it via 18 m to 36 m of grassed swales. These grassed swales will have minimal longitudinal slopes (0.5% to 1.5%) that will keep flow velocities low making them effective for pre-treatment and they will tend to increase the removal of TSS. The low flow conditions in these grassed areas will aid in filtering out coarse sediment from runoff and the grass will take up nutrients. For the infiltration trench to function adequately, the trench and detention area requires regular maintenance: the grass needs to be maintained at a minimum 75mm height; and annually, in the spring (and more frequently if necessary), any accumulated sediment needs to be removed from the grass and infiltration trench. Also, about once every five years (more frequently if ponding is observed during non-freezing conditions), the top 50 mm of clear stone (above the geotextile fabric) should be removed and replaced; and any geotextile material that has been damaged also be replaced.

As per the MOE Stormwater Management Planning and Design Manual, to remove 80% TSS an infiltration trench with a storage volume of 21.3 m<sup>3</sup> is required. An infiltration trench, with 21.8 m<sup>3</sup> storage volume is proposed (refer to calculations in Appendix C). Based on the geotechnical report the underlying soil is silty sand, with gravel, cobbles and boulders. This type of soil has an estimated infiltration rate of 30 to 75 mm/hr. However, as per the City of Ottawa LID Technical Guidance Report a factor of safety should be considered; and so a conservative safety correction factor of 2.5 has been applied to the estimated infiltration rates. Therefore, the design infiltration rates used are 12 to 30 mm/hr; and the trench, having a depth of 0.5 m, will have a drawdown time of 6.7 hours to 16.7 hours (as per the MOE Design Manual a maximum drawdown time of 24 to 48 hours is recommended). (An underlying soil having a design infiltration rates as low as 4.2 mm/hr (48-hour drawdown) would be acceptable.) As per the geotechnical report the long-term groundwater level is expected to be 2 to 3 m depth or 1 to 2 m below the bottom of the infiltration trench. The auger refusal at borehole closest to the proposed infiltration trench was at 2.7 m depth or about 1.7 m below the bottom of the infiltration trench. Therefore, since bedrock and groundwater are at least 1 m below the bottom of the infiltration trench neither are expected to be an issue.

More than half of the property is currently covered with compacted granular material, and has been that way for over 20 years, and since the granular material is considered impervious in water balance and infiltration calculations, the pre-development (existing) conditions has a calculated annual infiltration of only 95 mm/yr. The infiltration trench will promote water infiltration into the ground. In eastern Ontario, on hard surfaces approximately 150 mm of the 943 mm annual precipitation (or 16%) is lost to evapotranspiration (Eastern Ontario Water Resources Management Study (2001) & Carp River Watershed / Subwatershed Study). Therefore, 84% of the precipitation on hard surfaces is available for infiltration. As per Environment Canada's records at the Ottawa International Airport (1981-2010), there are on average 58.4 days per year where the precipitation is greater than 5 mm. Conservatively assuming only 5 mm of precipitation on each of the 58.4 days (and assuming 84% available for infiltration), 1,050 m<sup>3</sup> is available for infiltration from the runoff from the 4278 m<sup>2</sup> of the hard surfaces draining to the infiltration trench. Therefore, about 18.0 m<sup>3</sup> is available for infiltration for each of the 58.4 days. The infiltration trench, having a storage volume of 21.8 m<sup>3</sup> has the capacity to capture and infiltrate into the ground 100% of this volume or about 1,050 m<sup>3</sup> annually. Inserting the 1,050 m<sup>3</sup> into the water balance calculations, the post development annual infiltration for the property is 241 mm/year; which is 255% of the annual infiltration of the current condition and 234% of minimum 104 mm/year target. Refer to calculations in Appendix C.

As per the Ministry of Environment, Conservation and Parks' (MECP's) Source Protection Information Atlas, the source protection plan for the subject property is the Mississippi-Rideau Source Protection Plan; and as per this plan the subject property is within a Significant Groundwater Recharge Area with a score of 6 and within an area that has a Highly Vulnerable Aquifer with a score of 6. Therefore, spills potentially entering the groundwater via an infiltration trench can be a concern. Within the building; any spills caused by equipment maintenance will drain to the previously described oil interceptor located inside the building. Outside the building fluids leaking from vehicles may be possible. Regardless, as is required by the Environmental Compliance Approval (ECA – see page 6), within six months from the issuance of an ECA,

the owner is required to implement a spill contingency plan that includes a set of procedures describing how to mitigate the impacts of a spill. Among other items, the spill contingency plan would include:

- a site plan showing buildings, streets, drainage patterns, the infiltration trench and any other feature that could potentially be significantly impacted by a spill;
- physical obstructions and location of response and clean-up equipment;
- steps to be taken to report, contain, clean up and dispose of contaminants following a spill;
- a listing of telephone numbers for local clean-up company(ies) who may be called upon to assist in responding to spills; local emergency responders including health institution(s); and Ministry Spills Action Centre 1-800-268-6060;
- Safety Data Sheets (SDS) for each hazardous material which may be transported or stored within the area;
- the means (internal corporate procedures) by which the spill contingency plan is activated;
- a description of the spill response training provided to employees and the date(s) on which the training was provided and by whom; and
- an inventory of response and clean-up equipment available to implement the spill.

The spill contingency plan has to be kept in a conspicuous, readily accessible location on-site; and the plan needs to be amended as required by changes in the operation of the facility.

An erosion and sediment control plan has been developed to be implemented during construction, (see drawing C-4 and notes 2.1 to 2.6 on drawing C-6). In summary: to filter out construction sediment a silt fence barrier will be installed around the perimeter of the site where runoff will drain off the site; straw bale check dams will be installed at culverts; and any material deposited on a public road will be removed.

#### 4.2 QUANTITY CONTROL

As per the pre-consultation meeting with City staff (on December 17, 2020) for the previous stormwater management design, the stormwater quantity control measures were based on the post development release rate for the 5 and 100-year storm events being controlled to the flow produced by the pre-development conditions. However, since that time, the quantity control criterion, now typically required City, is to control the post development peak flows for the 5-year and 100-year storm events to peak flows during the 2-year storm event using a pre-development runoff coefficient or 0.50 (whichever is less); and a calculated time of concentration (but not less than 10 minutes). Since the drainage easement at the north end of the property is undevelopable it is not included in the calculations; and although 70% of the area is covered with granular material and has been that way for over 20 years, the City requires that the pre-development conditions be the conditions that existed prior to the placement of the granular material (sometime in the 1990s), which was a grassed field. Based on this City requirement, it is determined that pre-development condition reflected a runoff coefficient of 0.30 (as per City of Ottawa Sewer Design Guidelines, Table 5.7 – a pasture); and, using the Airport Formula, the time of concentration was 21.3 minutes. Using the Rational Method, and a time of concentration of 21.3 minutes, the pre-development 2-year peak flow is 27.98 L/s. Therefore, the maximum allowable release rate is 27.98 L/s for all storm events up to the 100-year event. Refer to calculations in Appendix C.

Stormwater will be stored within the development in a stormwater detention area. The stormwater released from the detention area will discharge to the roadside ditch. The Modified Rational Method is used to calculate the required storage volume. The runoff coefficients for the 100-year event are increased by 25% to maximum 1.00.

#### Drainage Area I (Uncontrolled Flow Off Site – 686 m<sup>2</sup>)

Areas around the perimeter of the property will drain uncontrolled off site. The flow rates are calculated at a time of concentration of 10 minutes.

	100-Year Event	5-Year Event
Maximum Flow Rate	14.42 L/s	7.16 L/s

### Drainage Area II (6,013 m<sup>2</sup>)

An inlet control device (ICD) located in the inlet of the culvert in the stormwater detention area will control the release of stormwater from the property and will discharge to the roadside ditch near the southeast corner of the property. The ICD will restrict the flow and force the stormwater to rise in the detention area. The ICD shall be a plug style with a round orifice design manufactured by Pedro Plastics (or approved equal) and each shall be sized by the manufacturer for a discharge rate of 13.56 L/s at 0.81 m head. It is calculated that an orifice area of 5,585 mm<sup>2</sup> ( $\pm$ 84 mm diameter) and a discharge coefficient of 0.61 will restrict the outflow rate to 13.56 L/s at a head of 0.81 m. Based on this orifice the maximum outflow rate for the 5-year storm event is calculated to be 10.15 L/s at 0.45 m. A broad-crested weir will control the release of stormwater to the roadside ditch in the event that the 100-year storm is exceeded (or if there is blockage). The broad-crested weir will be a concrete curb with a 2.00 m long depressed section set at the 100-year ponding elevation of 117.15. The weir, for example, would release 30.22 L/s (the 100-year ICD outflow rate) at 0.025 m water depth above the weir.

	100-Year Event	5-Year Event
Maximum ICD Release Rate	13.56 L/s	10.15 L/s
Maximum Ponding Elevation	117.15 m	116.79 m
Maximum Volume Stored	216.81 m <sup>3</sup>	101.00 m <sup>3</sup>

### Entire Site

	100-Year Event	5-Year Event
Pre-Development Flow Rate	270.92 L/s	140.12 L/s
Maximum Allowable Release Rate	27.98 L/s	27.98 L/s
Maximum Release Rate	27.98 L/s	17.30 L/s
Maximum Volume Required & Stored	216.81 m <sup>3</sup>	101.00 m <sup>3</sup>

The maximum post-development release rate during the 100-year event was calculated to be 27.98 L/s, which is 90% less than the pre-development flow rate and equal to the maximum allowable release rate. To achieve the maximum allowable release rate, a maximum storage volume of 216.81 m<sup>3</sup> is required and provided. The maximum post-development release rate during the 5-year event was calculated to be 17.30 L/s, which is 88% less than the pre-development flow rate and 38% less than the maximum allowable release rate.

It is expected that the Ministry of Environment, Conservation and Parks (MECP) will consider the property "industrial lands" and an Environmental Compliance Approval (ECA) will be required for the proposed stormwater management facility.

Pre and post development flows off the site outlets to the McGee Side Road roadside ditch. The existing culvert crossing John Cavanaugh Drive has capacity of approximately 500 L/s before overtopping the road. Upstream and downstream of this culvert the roadside ditches have greater capacities. As mentioned above, the proposed stormwater management quantity control measures will significantly reduce the existing (pre-development flow) by almost 88 to 90% during the 5-year and 100-year events, respectively. The post development flowrates from the subject site will represent only about 6% of the capacity of the culvert during the 100-year event (reduced from about 54%) and only about 3% during the 5-year event (reduced from about 28%). Therefore, post development the residual capacity of the roadside ditches will increase. Refer to calculations in Appendix C.

## 5.0 CONCLUSIONS

1. It is expected that the two proposed tanks, totaling 20,000 gallons (90,920 L) in volume will provide an adequate water supply for firefighting, since the volume meets the OBC requirements.
2. As concluded in the Hydrogeological Assessment and Terrain Analysis, prepared by Paterson Group (File: PH4146-LET.01, dated June 2, 2021): *"The results of the water supply assessment have provided satisfactory evidence that the water supply aquifer underlying the subject site can support the proposed commercial development from both a quality and quantity perspective."*
3. An on-site septic system is proposed. An application for a septic permit will be submitted to the Ottawa Septic System Office (OSSO) shortly.
4. To achieve quality control as part of the stormwater management design, an infiltration trench, designed to remove 80% TSS, is proposed.
5. As per water balance calculations the infiltration trench will help achieve a post development annual infiltration for the property of 241 mm/year; greater than the minimum 104 mm/year target.
6. An Erosion & Sediment Control Plan has been developed to be implemented during construction.
7. The maximum post-development release rate during the 100-year event was calculated to be 90% less than the pre-development flow rate and equal to the maximum allowable release rate. The maximum post-development release rate during the 5-year event was calculated to be 88% less than the pre-development flow rate and 38% less than the maximum allowable release rate.
8. It is expected that the Ministry of Environment, Conservation and Parks (MECP) will consider the property "industrial lands" and an Environmental Compliance Approval (ECA) will be required for the proposed stormwater management facility.

Prepared by D.B. Gray Engineering Inc.

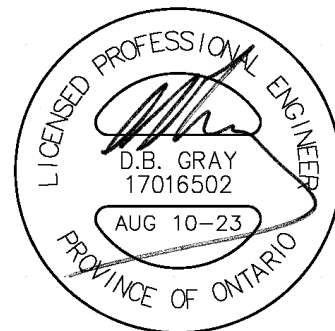

NOT VALID UNLESS  
SIGNED & DATED



## **APPENDIX A**

### WATER SERVICING



# D.B. Gray Engineering Inc.

*Stormwater Management - Grading & Drainage - Storm & Sanitary Sewers - Watermains*

700 Long Point Circle  
Ottawa, Ontario K1T 4E9

613-425-8044  
d.gray@dbgrayengineering.com

June 14, 2023

2167 McGee Side Road  
Office / Warehouse Building  
Ottawa, Ontario

## FIRE FLOW CALCULATIONS FUS Method

RFF = Required Fire flow in litres per minutes  
=  $220CA^{0.5}$

C = Coefficient related to the type of construction  
= 0.8 Noncombustible Construction

A = Total floor area in square meters (excluding basements at least 50% below grade)

Mezzanine:	218	sq.m
Ground Floor:	1,635	sq.m
	<u>1,853</u>	sq.m

RFF = 7,576 L/min  
= 8,000 L/min (rounded to nearest 1,000 L/min)

Occupancy and Contents Adjustment Factor

15% Free Burning Contents

RFF = 9,200 L/min

Exposure Adjustment Charge

Charge	Side	Separation	Construction	Length	Storeys	Length • Height
0%	North	>30 m				0
0%	East	>30 m				0
0%	South	>30 m				0
0%	West	>30 m				0
0%	Total Exposure Charge					
0	L/min Exposure Increase					

RFF = 9,200 L/min  
= 9,000 L/min (rounded to nearest 1000 L/min)

Required duration of fire flow in hours

= 2.0 h as per Required Duration of Fire Flow (FUS 2020 Table 1)

Required water supply in litres

= 1,080,000 L



# D.B. Gray Engineering Inc.

*Stormwater Management - Grading & Drainage - Storm & Sanitary Sewers - Watermains*

700 Long Point Circle  
Ottawa, Ontario K1T 4E9

613-425-8044  
d.gray@dbgrayengineering.com

June 14, 2023

2167 McGee Side Road  
Office / Warehouse Building  
Ottawa, Ontario

## FIRE FLOW CALCULATIONS OBC Method

As per "Required Minimum Water Supply Flow Rate" as calculated using the Ontario Building Code - Appendix A - Article A-3.2.5.7 "Water Supply For Fire Fighting".

K = Water supply coefficient as per OBC A-3.2.5.7. Table 1  
= 12 Group F, Division 3 Occupancy, Building is of noncombustible construction with fire separations without fire resistance ratings.

V = Building volume in cubic meters

Floor Area (sq.m)	Average Height (m)	Volume (cu.m)
1,635	4.35	7,120

S<sub>Total</sub> = Total of spatial coefficients from exposure distances

$$= 1.0 + S_{\text{Side 1}} + S_{\text{Side 2}} + S_{\text{Side 3}} + S_{\text{Side 4}}$$

	Spatial Coefficient	Exposure Distance (m)	
S <sub>Side 1</sub>	0.0	33.3	(to NW property line)
S <sub>Side 2</sub>	0.0	32.3	(to centerline John Cavanaugh Dr)
S <sub>Side 3</sub>	0.0	29.7	(to centerline McGee Side Rd)
S <sub>Side 4</sub>	0.0	19.6	(to SW adjacent building)
S <sub>Total</sub>	1.0		

Q = KVS<sub>Tot</sub> (required water supply in litres)

$$Q = 85,435 \text{ L}$$

$$= 2,700 \text{ L/min as per OBC A-3.2.5.7. Table 2}$$

$$= 45 \text{ L/s}$$

Required duration of fire flow in minutes

$$= 30 \text{ min}$$

Required water supply in litres

$$= 81,000 \text{ L}$$

## **APPENDIX B**

### SANITARY SERVICING

## GR-5000 SERIES

### Certified oil interceptor

For occasional automobile mechanics, such as body workshops, car windows, aesthetics, etc.

The interceptor is made of steel coated with enamel antirust paint, including a flow rate regulator, a 2" blowhole at the entrance and exit, a non-skid cover bolted airtight. A warning signal is built in a PVC case ULC + CSA approved to be fixed to the workshop wall (pre-fabricated at factory) and is connected to the interceptor using a 10 foot teck that is buried underground.

A 115 Volt – 15 Amp outlet is required at the workshop for the warning signal. The oil interceptor must be drained at least once a year.

Note: A sand interceptor is required upstream the oil interceptor, with an appropriate capacity (GR-520 series) and has to be drained more frequently to avoid any overflow. (4.7.6)

### OPTIONS(SUFFIX)

- E:** Extension (dim. 'C' specify)
- LP:** Thermal epoxy coated
- SS:** Stainless steel
- XH:** Extra heavy traffic cover
- GRP:** Made of polypropylene
- SB:** Steel sediment basket
- TECK:** Total length wire

### TECHNICAL DRAWINGS

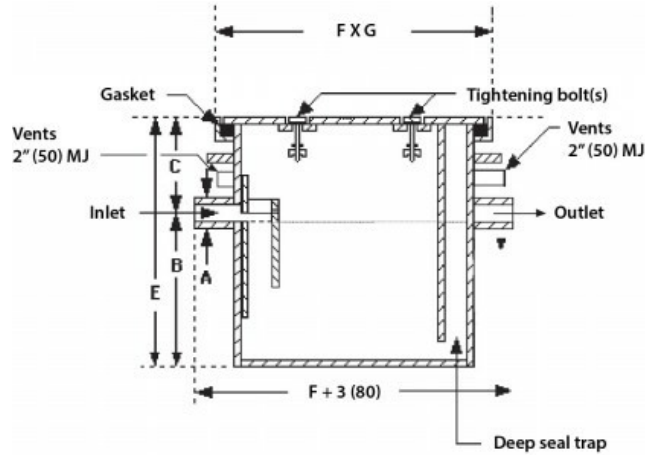

### SPECIFICATIONS

	Model	GPM	Nom. Dia. M.J.			Dimension			Used oil	Weight	Car Unit
			A	B	C	height	length	width			
						E	F	G			
Unit			<i>in (mm)</i>	<i>in (mm)</i>	<i>in (mm)</i>	<i>in (mm)</i>	<i>in (mm)</i>	<i>in (mm)</i>	<i>gallons (litres)</i>	<i>lbs (kg)</i>	
<input type="checkbox"/>	GR-5020	20	3 (75)	14 (360)	6 (150)	20 (500)	32 (810)	24 (610)	20 (90)	190 (86)	1
<input type="checkbox"/>	GR-5025	25	3 (75)	16 (405)	6 (150)	22 (550)	32 (810)	24 (610)	20 (90)	200 (91)	2
<input checked="" type="checkbox"/>	GR-5035	35	3 (75)	19 (480)	6 (150)	25 (635)	32 (810)	24 (610)	20 (90)	215 (98)	3
<input type="checkbox"/>	GR-5050	50	4 (100)	24 (610)	6 (150)	30 (760)	32 (810)	24 (610)	20 (90)	240 (109)	4
<input type="checkbox"/>	GR-5060	60	4 (100)	35 (890)	6 (150)	41 (1040)	32 (810)	24 (610)	20 (90)	295 (134)	5
<input type="checkbox"/>	GR-5075	75	4 (100)	24 (610)	6 (150)	30 (760)	44 (1120)	32 (810)	50 (225)	375 (170)	6

## **APPENDIX C**

### STORMWATER MANAGEMENT

## STORMWATER MANAGEMENT CALCULATIONS

The orifice calculations are based on the following formula:

$$Q = C_d \times A_o \sqrt{2gh} \times 1000$$

where:

Q = flowrate in litres per second

$C_d$  = coefficient of discharge

$A_o$  = orifice area in sq.m.

g = 9.81 m/s<sup>2</sup>

h = head above orifice in meters

The length of the broad-crested weir is based on the following formula:

$$L = Q / (1.705 \times H^{3/2})$$

where:

L = the length of the weir in m

Q = the flow rate in m<sup>3</sup>/s

H = the depth of water above the top of the weir

Storage calculations for the stormwater detention area are based on the following formula for volume of a prismatic shape (the formula is accurate if both length and width are changing proportionally):

$$V = (A_{top} + A_{bottom} + (A_{top} \times A_{bottom}))^{0.5} / 3 \times d$$

where:

V = volume in cu.m.

$A_{top}$  = area of pond in sq.m.

$A_{bottom}$  = area of bottom of depressed area

d = ponding depth in meters

2167 McGee Side Road  
Ottawa, Ontario

## INFILTRATION CALCULATIONS

### DRAINAGE AREA II

Roof Area:	1635	sq.m
Asphalt/Concrete Area:	2514	sq.m
Gravel Area:	129	sq.m
Landscaped Area:	<u>1735</u>	sq.m

Total Catchment Area 6013 sq.m.

Pervious (Landscaped) Area:	1735	sq.m.
Total Catchment Area:	6013	sq.m.
Percentage Pervious:	29%	
Percentage Impervious:	71%	

Require Storage Volume \*: 71% Impervious Level 35.4 cu.m./ha (extrapolated from Table 3.2 \*)  
(for 80% TSS removal) 21.3 cu.m. ( 6013 ) sq.m.

\* As per MOE Stormwater Management Planning and Design Manual, March 2003

#### Infiltration Trench

Depth	Area	Total Volume	Void Volume
m	sq.m.	cu.m.	40% cu.m.
0.50	109	54.5	21.8

---

Silty sand, with gravel, cobbles and boulders

---

#### Infiltration Rate

75 mm/hr High End of Range

30 mm/hr Low End of Range

#### Design Infiltration Rate (2.5 safety factor)

30 mm/hr High End of Range

Time to Draw Down: 6.7 Hours

12 mm/hr Low End of Range

Time to Draw Down: 16.7 Hours



# 2167 McGee Side Road Ottawa, Ontario

## INFILTRATION CALCULATIONS

### DRAINAGE AREA II

			C
Roof Area:	1635	sq.m.	0.90
Asphalt/Concrete Area:	2514	sq.m.	0.90
Gravel Area:	129	sq.m.	0.80
Landscaped:	<u>1735</u>	<u>sq.m.</u>	<u>0.20</u>
Total Catchment Area	6013	sq.m.	0.70

Required Volume Required to Capture: 5 mm rain event: 20.9 cu.m.

64% of days with precipitation are 5mm or less

\* Ottawa International Airport (1981-2010)

Infiltration Trench			
		Total	Void
Depth	Area	Volume	40%
m	sq.m.	cu.m.	cu.m.
0.50	109	54.5	21.8

Silty sand, with gravel, cobbles and boulders

Infiltration Rate		
	75 mm/hr	High End of Range
	30 mm/hr	Low End of Range
Design Infiltration Rate (2.5 safety factor)		
	30 mm/hr	High End of Range
Time to Draw Down:	6.7 Hours	
	12 mm/hr	Low End of Range
Time to Draw Down:	16.7 Hours	

2167 McGee Side Road  
Ottawa, Ontario

Water Balance and Infiltration Calculations

Water Balance is based on the equation: Mean Annual Precipitation - Change in Groundwater Storage - Evapotranspiration = Runoff + Infiltration

Where: Long term changes to groundwater storage are assumed to be negligible and  
Short term or seasonal changes to groundwater are assumed to balance out over the year.

Therefore: Mean Annual Precipitation - Evapotranspiration = Runoff + Infiltration

Infiltration is based on the equations: Surplus (available for infiltration) = Mean Annual Precipitation - Evapotranspiration and  
Infiltration = Surplus x Infiltration Coefficient and  
Infiltration Coefficient = Topography Factor + Soil Factor + Vegetation Factor  
(as per the MOE SWM Planning & Design Manual, 2003 - see below)

Pre-Development  
(assume agricultural pasture - prior to circa 1990)

	Area (sq.m.)	Precipitation + (mm/yr)	Evapo-transpiration ++ (mm/yr)	Surplus (mm/yr)	Topography Factor *	Soil Factor **	Vegetation Factor ***	Infiltration Coefficient	Infiltration (mm/yr)
*Forest" (Ravine)	922	943	560	383	0.1	0.4	0.2	0.70	268
"Meadows"	6699	943	390	553	0.15	0.4	0.1	0.65	359
Total:	7621							Weighted Average:	348

Pre (Existing) Development

	Area (sq.m.)	Precipitation + (mm/yr)	Evapo-transpiration ++ (mm/yr)	Surplus (mm/yr)	Topography Factor *	Soil Factor **	Vegetation Factor ***	Infiltration Coefficient	Infiltration (mm/yr)
*Forest" (Ravine)	922	943	560	383	0.1	0.4	0.2	0.70	268
Landscaped	1986	943	575	368	0.15	0.4	0.1	0.65	239
Hard Surfaces	4713	943	150	793				0.00	0
Total:	7621							Weighted Average:	95

Post Development

	Area (sq.m.)	Precipitation + (mm/yr)	Evapo-transpiration ++ (mm/yr)	Surplus (mm/yr)	Topography Factor *	Soil Factor **	Vegetation Factor ***	Infiltration Coefficient	Infiltration (mm/yr)	Volume Including Infiltration Trench (cu.m.)	Infiltration (mm/yr)
Undeveloped	922	943	560	383	0.1	0.4	0.2	0.70	268	247	268
Landscaped	2260	943	575	368	0.15	0.4	0.1	0.65	239	541	239
Hard Surfaces	4278	943	150	793				0.00	0	1050	246
Total:	7621							Weighted Average:	103	1838	241

	mm	Days with Precipitation +	Hard Surfaces Surplus / Precipitation	Hard Surfaces Area (sq.m.)	Hard Surfaces Available Annual Volume (cu.m.)	Hard Surfaces Annual Percentage Captured	Hard Surfaces Annual Volume Captured (cu.m.)	Required Volume of Infiltration Trench (cu.m.)
>=	0.2	163.6	0.84	4278	118	100%	118	0.7
>=	5	58.4	0.84	4278	1050	100%	1050	18.0
>=	10	30.0	0.84	4278	1079	100%	1079	36.0
>=	25	5.5	0.84	4278	495	100%	495	89.9

+ Ottawa International Airport (1981-2010)  
++ Eastern Ontario Water Resources Management Study (2001) & Carp River Watershed / Subwatershed Study

\* Topography: Flat Land, average slope < 0.6m/km (<.06%)  
Rolling Land, average slope 2.8 to 3.8m/km (0.28% to 0.38%)  
Hilly Land, average slope 28 to 47m/km (2.8 to 4.7%)

\*\* Soil: Tight impervious clay  
Medium combination of clay and loam  
Open sandy loam

\*\*\* Cover: Cultivated Lands  
Woodland

Factor	Subject Property
0.3	
0.2	= 0.15 (pre-development)
0.1	= .1 (post development)
0.1	
0.2	= 0.15 for silt
0.4	
0.1	= 0.1 (post-development)
0.2	= 0.15 (meadows / woodland - pre-development)

# Summary Tables

ONE HUNDRED YEAR EVENT					
Drainage Area	Pre Development Flow Rate (L/s)	Maximum Allowable Release Rate (L/s)	Maximum Release Rate (L/s)	Maximum Volume Required (cu.m)	Maximum Volume Stored (cu.m)
AREA I (Uncontrolled Flow Off Site)	-	-	14.42	-	-
AREA II	-	-	13.56	216.81	216.81
TOTAL	270.92	27.98	27.98	216.81	216.81

FIVE YEAR EVENT					
Drainage Area	Pre Development Flow Rate (L/s)	Maximum Allowable Release Rate (L/s)	Maximum Release Rate (L/s)	Maximum Volume Required (cu.m)	Maximum Volume Stored (cu.m)
AREA I (Uncontrolled Flow Off Site)	-	-	7.16	-	-
AREA II	-	-	10.15	101.00	101.00
TOTAL	140.12	27.98	17.30	101.00	101.00

## 2167 McGee Side Road

Ottawa, Ontario

## STORMWATER MANAGEMENT CALCULATIONS

## Rational Method &amp; Modified Rational Method

## 100-Year Pre (Existing) Development Flow Rate

			C	
Roof Area:	0	sq.m	1.00	
Asphalt/Concrete Area:	0	sq.m	1.00	
Gravel Area:	4713	sq.m	1.00	(City of Ottawa Sewer Design Guidelines - Table 5.7) x 1.25
Flat Woodland / Pasture Area:	1986	sq.m	0.375	
Total Catchment Area:	6699	sq.m	0.81	

Bransby Williams Formula (Used when  $C \geq 0.40$ )

$$T_c = \frac{0.057 \cdot L}{S_w^{0.2} \cdot A^{0.1}} \text{ min}$$

Sheet Flow Distance (L):	105	m
Slope of Land (Sw):	2	%
Area (A):	0.6699	ha
Time of Concentration (Sheet Flow):	5	min
Time of Concentration:	10	min
Rainfall Intensity (i):	179	mm/hr (100-year event)

100-Year Pre-development Flow Rate (2.78AiC): 270.92 L/s

## 5-Year Pre (Existing) Development Flow Rate

			C	
Roof Area:	0	sq.m	0.90	
Asphalt/Concrete Area:	0	sq.m	0.90	
Gravel Area:	4713	sq.m	0.90	(City of Ottawa Sewer Design Guidelines - Table 5.7)
Flat Woodland / Pasture Area:	1986	sq.m	0.30	
Total Catchment Area:	6699	sq.m	0.72	

Bransby Williams Formula (Used when  $C \geq 0.40$ )

$$T_c = \frac{0.057 \cdot L}{S_w^{0.2} \cdot A^{0.1}} \text{ min}$$

Sheet Flow Distance (L):	105	m
Slope of Land (Sw):	2	%
Area (A):	0.6699	ha
Time of Concentration (Sheet Flow):	5	min
Time of Concentration:	10	min
Rainfall Intensity (i):	104	mm/hr (5-year event)

5-Year Pre-development Flow Rate (2.78AiC): 140.12 L/s

## 2-Year Pre-Development Flow Rate

(assuming a grassed field i.e. prior to the placement of the granular material)

### and Maximum Allowable Release Rate

			C	
Roof Area:	0	sq.m	0.90	
Asphalt/Concrete Area:	0	sq.m	0.90	
Gravel Area:	0	sq.m	0.80	
Flat Woodland / Pasture Area:	6699	sq.m	0.30	(City of Ottawa Sewer Design Guidelines - Table 5.7)
 Total Catchment Area:	 6699	 sq.m	 0.30	

Airport Formula (Used when C < 0.40)

$$T_c = \frac{3.26 \cdot (1.1 - C) \cdot L^{1/2}}{S_w^{0.33}} \text{ min}$$

Sheet Flow Distance (L):	105	m
Slope of Land (Sw):	2	%
Time of Concentration (Sheet Flow):	21.3	min

Rainfall Intensity (i): 50 mm/hr (2-year event)

Maximum Allowable Release Rate (2.78AiC): 27.98 L/s

# DRAINAGE AREA I (Uncontrolled Flow Off Site)

(ONE HUNDRED YEAR EVENT)

			C
Roof Area:	0	sq.m	1.00
Asphalt/Concrete Area:	147	sq.m	1.00
Gravel Area:	14	sq.m	0.875
Landscaped Area:	<u>525</u>	<u>sq.m</u>	<u>0.25</u>
Total Catchment Area:	686	sq.m	0.42
Area (A):	686	sq.m	
Time of Concentration:	10	min	
Rainfall Intensity (i):	179	mm/hr	
Runoff Coeficient (C):	0.42		
Release Rate (2.78AiC):	14.42	L/s	

# DRAINAGE AREA II

(ONE HUNDRED YEAR EVENT)

			C
Roof Area:	1635	sq.m	1.00
Asphalt/Concrete Area:	2514	sq.m	1.00
Gravel Area:	129	sq.m	0.875
Landscaped Area:	<u>1735</u>	<u>sq.m</u>	<u>0.25</u>

Total Catchment Area: 6013 sq.m 0.78

Water Elevation: 117.15 m

Invert of Inlet of Culvert: 116.30 m

Centroid of ICD Orifice: 116.34 m  
(ICD in Inlet of Culvert)

Head: 0.81 m

Orifice Diameter: 84 mm

Orifice Area: 5585 sq.mm

Coefficient of Discharge: 0.61

Maximum Release Rate: 13.56 L/s

Bottom Area (sq.m)	Top Area (sq.m)	Avg. Depth (m)	Volume
109	203	0.85	130.45 cu.m
70	166	0.75	86.36 cu.m

Achieved Volume: 216.81 cu.m

Maximum Volume Required: 216.81 cu.m

DRAINAGE AREA II  
 (ONE HUNDRED YEAR EVENT)  
 (Continued)

Time (min)	i (mm/hr)	2.78AiC (L/s)	Release Rate (L/s)	Stored Rate (L/s)	Stored Volume (cu.m)
5	243	316.82	13.56	303.26	90.98
10	179	233.09	13.56	219.53	131.72
15	143	186.53	13.56	172.97	155.67
20	120	156.58	13.56	143.02	171.62
25	104	135.56	13.56	122.00	183.00
30	92	119.92	13.56	106.36	191.45
35	83	107.80	13.56	94.24	197.89
40	75	98.09	13.56	84.53	202.88
45	69	90.14	13.56	76.58	206.75
50	64	83.48	13.56	69.92	209.77
55	60	77.83	13.56	64.27	212.09
60	56	72.96	13.56	59.40	213.85
65	53	68.72	13.56	55.16	215.13
70	50	64.99	13.56	51.43	216.02
75	47	61.69	13.56	48.12	216.56
80	45	58.73	13.56	45.17	216.81
85	43	56.07	13.56	42.51	216.80
90	41	53.67	13.56	40.10	216.56
95	39	51.48	13.56	37.92	216.12
100	38	49.48	13.56	35.92	215.50
105	36	47.64	13.56	34.08	214.71
110	35	45.95	13.56	32.39	213.78
115	34	44.39	13.56	30.83	212.72
120	33	42.94	13.56	29.38	211.53
125	32	41.59	13.56	28.03	210.23
130	31	40.33	13.56	26.77	208.82
135	30	39.16	13.56	25.60	207.33
140	29	38.05	13.56	24.49	205.74
145	28	37.02	13.56	23.46	204.07
150	28	36.04	13.56	22.48	202.33
180	24	31.20	13.56	17.64	190.52
210	21	27.60	13.56	14.04	176.90
240	19	24.81	13.56	11.25	161.97
270	17	22.58	13.56	9.01	146.03
300	16	20.74	13.56	7.18	129.29
330	15	19.21	13.56	5.65	111.90
360	14	17.91	13.56	4.35	93.97
390	13	16.79	13.56	3.23	75.58
420	12	15.82	13.56	2.25	56.80
450	11	14.96	13.56	1.40	37.68
480	11	14.20	13.56	0.63	18.26
510	10	13.52	13.52	0.00	0.00
540	10	12.90	12.90	0.00	0.00
570	9	12.35	12.35	0.00	0.00
600	9	11.85	11.85	0.00	0.00



# FIVE YEAR EVENT

## DRAINAGE AREA I (Uncontrolled Flow Off Site)

(FIVE YEAR EVENT)

			C
Roof Area:	0	sq.m	0.90
Asphalt/Concrete Area:	147	sq.m	0.90
Gravel Area:	14	sq.m	0.70
Landscaped Area:	525	sq.m	0.20
Total Catchment Area:	686	sq.m	0.36
Area (A):	686	sq.m	
Time of Concentration:	10	min	
Rainfall Intensity (i):	104	mm/hr	
Runoff Coeficient (C):	0.36		
Release Rate (2.78AiC):	7.16	L/s	

# DRAINAGE AREA II

(FIVE YEAR EVENT)

			C
Roof Area:	1635	sq.m	0.90
Asphalt/Concrete Area:	2514	sq.m	0.90
Gravel Area:	129	sq.m	0.70
Landscaped Area:	<u>1735</u>	<u>sq.m</u>	<u>0.20</u>
Total Catchment Area:	6013	sq.m	0.69

Water Elevation: 116.79 m

Invert of Inlet of Culvert: 116.30 m

Centroid of ICD Orifice: 116.34 m  
(ICD in Inlet of Culvert)

Head: 0.45 m

Orifice Diameter: 84 mm

Orifice Area: 5585 sq.mm

Coefficient of Discharge: 0.61

Maximum Release Rate: 10.15 L/s

Bottom Area (sq.m)	Top Area (sq.m)	Avg. Depth (m)	Volume
109	150	0.49	63.65 cu.m
70	119	0.40	37.35 cu.m

Achieved Volume: 101.00 cu.m

Maximum Volume Required: 101.00 cu.m

# DRAINAGE AREA II

(FIVE YEAR EVENT)

(Continued)

Time (min)	i (mm/hr)	2.78AiC (L/s)	Release Rate (L/s)	Stored Rate (L/s)	Stored Volume (cu.m)
5	141	163.72	10.15	153.57	46.07
10	104	120.83	10.15	110.68	66.41
15	84	96.90	10.15	86.75	78.08
20	70	81.47	10.15	71.32	85.58
25	61	70.62	10.15	60.47	90.71
30	54	62.54	10.15	52.39	94.30
35	49	56.26	10.15	46.12	96.85
40	44	51.24	10.15	41.09	98.62
45	41	47.11	10.15	36.97	99.82
50	38	43.66	10.15	33.52	100.56
55	35	40.73	10.15	30.58	100.93
60	33	38.20	10.15	28.06	101.00
65	31	36.00	10.15	25.85	100.83
70	29	34.06	10.15	23.92	100.44
75	28	32.34	10.15	22.19	99.88
80	27	30.80	10.15	20.66	99.15
85	25	29.42	10.15	19.27	98.29
90	24	28.17	10.15	18.02	97.31
95	23	27.03	10.15	16.88	96.22
100	22	25.98	10.15	15.84	95.03
105	22	25.03	10.15	14.88	93.76
110	21	24.15	10.15	14.00	92.41
115	20	23.33	10.15	13.19	90.98
120	19	22.58	10.15	12.43	89.49
125	19	21.87	10.15	11.73	87.94
130	18	21.22	10.15	11.07	86.34
135	18	20.60	10.15	10.46	84.69
140	17	20.03	10.15	9.88	82.99
145	17	19.48	10.15	9.34	81.24
150	16	18.97	10.15	8.83	79.46
180	14	16.44	10.15	6.30	68.02
210	13	14.56	10.15	4.41	55.62
240	11	13.10	10.15	2.95	42.50
270	10	11.93	10.15	1.78	28.85
300	9	10.97	10.15	0.82	14.76
330	9	10.16	10.15	0.02	0.32
360	8	9.48	9.48	0.00	0.00
390	8	8.89	8.89	0.00	0.00
420	7	8.38	8.38	0.00	0.00
450	7	7.93	7.93	0.00	0.00
480	6	7.53	7.53	0.00	0.00
510	6	7.17	7.17	0.00	0.00
540	6	6.85	6.85	0.00	0.00
570	6	6.55	6.55	0.00	0.00
600	5	6.29	6.29	0.00	0.00

2167 McGee Side Road  
Ottawa, Ontario

## BROAD CRESTED WEIR CALCULATIONS

### 1:100 YEAR EVENT

#### DRAINAGE AREA II

(ONE HUNDRED YEAR EVENT)

Length of Weir based on an assumed coefficient of discharge (Cd):

if Q =	13.56	L/s (maximum 100-year release rate)	assumes Cd= 0.577
=	0.01356	cu.m/s	(assumes P/H is large)
& H =	0.025	m (max. depth of water above top of weir)	
then L =	2.00	m (length of weir)	$L = Q / ((1.705) \times H^{(3/2)})$

Length of Weir based on a calculated coefficient of discharge (Cd):

if P =	0.76	m (depth of pond)	
& Lp =	10.0	m (width of pond perpendicular to direction of flow)	
then Vp =	0.00	m/s (velocity in pond)	$Vp = Q / ((P+H) / Lp)$
& E =	0.025	m (energy)	$E = H + V^2/2g$
& Cd =	0.577		$= 0.577 \times (E/H)^{(3/2)}$
if Q =	13.56	L/s (maximum permitted flow)	
=	0.01356	cu.m/s	
& H =	0.025	m (depth of water above top of weir)	
then L =	2.00	m (length of weir)	$L = Q / (Cd^{(2/3)} \times (2 \times 9.81)^{(1/2)} \times H^{(3/2)})$

# HY-8 Analysis Results

## Culvert Summary Table - Existing 23m - 800mm

Culvert Crossing: 2267 McGee Side Rd

Total Discharge (cms)	Culvert Discharge (cms)	Headwater Elevation (m)	Inlet Control Depth (m)	Outlet Control Depth (m)	Flow Type	Normal Depth (m)	Critical Depth (m)	Outlet Depth (m)	Tailwater Depth (m)	Outlet Velocity (m/s)	Tailwater Velocity (m/s)
0.00	0.00	115.31	0.00	0.0	0-NF	0.00	0.00	0.00	0.00	0.00	0.00
0.05	0.05	115.46	0.11	0.15	3-M1t	0.10	0.07	0.25	0.25	0.26	0.26
0.10	0.10	115.55	0.16	0.24	3-M1t	0.15	0.12	0.33	0.33	0.40	0.32
0.15	0.15	115.62	0.22	0.31	3-M1t	0.20	0.16	0.38	0.38	0.52	0.35
0.20	0.20	115.69	0.26	0.38	3-M1t	0.24	0.19	0.42	0.42	0.63	0.37
0.25	0.25	115.76	0.31	0.45	3-M1t	0.29	0.22	0.46	0.46	0.74	0.40
0.30	0.30	115.82	0.35	0.51	3-M1t	0.33	0.25	0.49	0.49	0.85	0.41
0.35	0.35	115.89	0.38	0.58	7-M1t	0.39	0.27	0.52	0.52	0.96	0.43
0.40	0.40	115.98	0.42	0.67	3-M2t	0.56	0.29	0.55	0.55	1.07	0.45
0.45	0.45	116.08	0.46	0.77	4-FFf	0.56	0.32	0.56	0.57	1.20	0.46
0.50	0.50	116.19	0.50	0.88	4-FFf	0.56	0.34	0.56	0.59	1.34	0.47

# Crossing - 2267 McGee Side Rd, Design Discharge - 0.50 cms

Culvert - Existing 23m - 800mm, Culvert Discharge - 0.50 cms

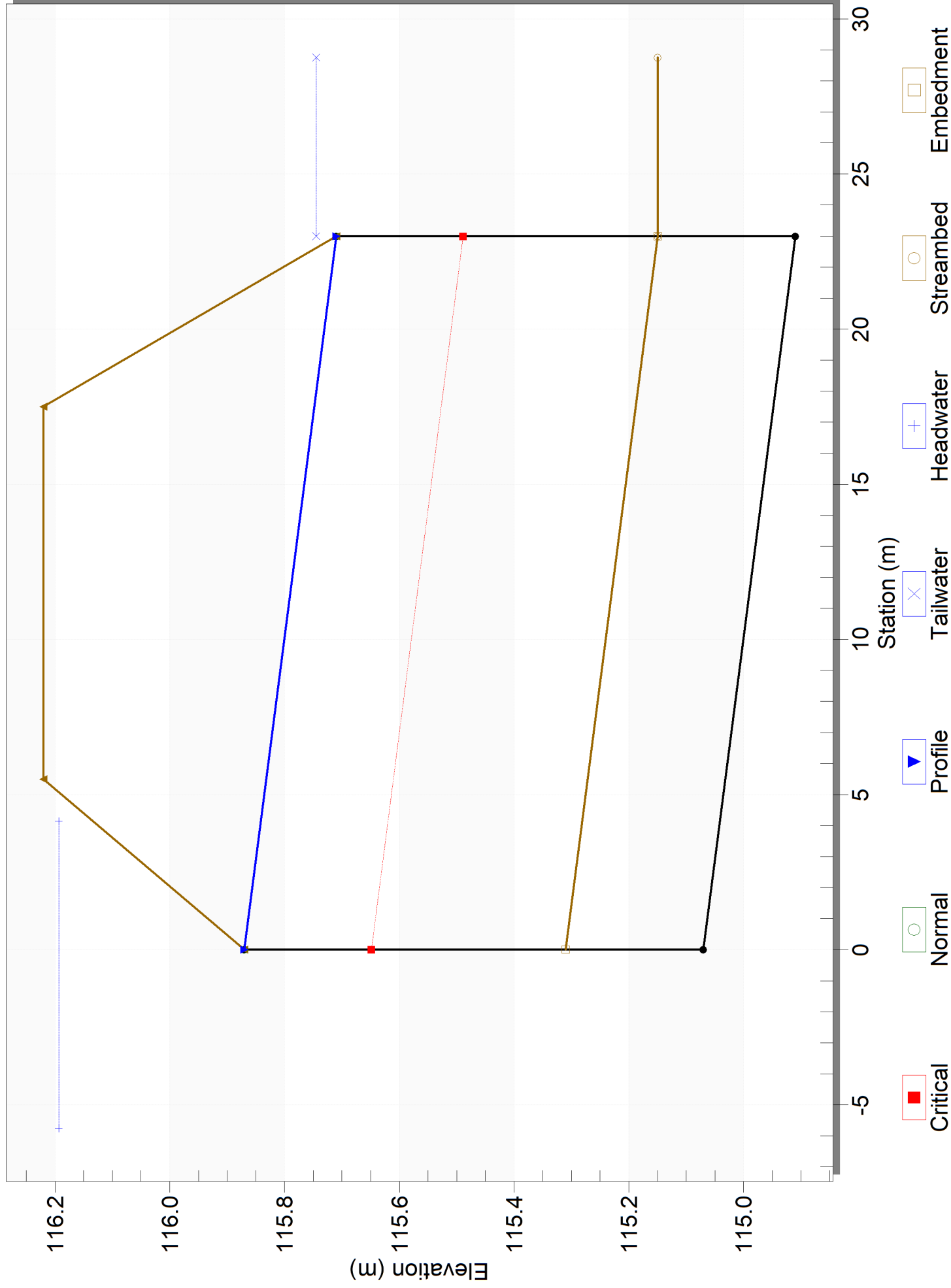

## 2167 McGee Side Road Ottawa, Ontario

### McGee Roadside Ditch Upstream of Existing Culvert Crossing John Cavanaugh Drive

Culvert capacity: 0.5 cu.m./s

Ditch Slope: 3.9%

Ditch Manning Roughness Coefficient n: 0.10 dense weeds as high as flow

Road Side Slope: 3 :1

Lot Side Slope: 3 :1

Ditch Bottom Width: - m

Water Depth: 0.48 m

Water Top Width: 2.87

Water Cross-Section Area: 0.69 sq.m.

Wetted Perimeter: 3.02 m

Hydraulic Radius: 0.23 m

Velocity: 0.73 m/s

Based on water depth

Velocity: 0.73 m/s

Using Manning's Formula:

### McGee Roadside Ditch Downstream of Existing Culvert Crossing John Cavanaugh Drive

Culvert capacity: 0.5 cu.m./s

Ditch Slope: 1.2%

Ditch Manning Roughness Coefficient n: 0.10 dense weeds as high as flow

Road Side Slope: 3 :1

Lot Side Slope: 3 :1

Ditch Bottom Width: - m

Water Depth: 0.60 m

Water Top Width: 3.57

Water Cross-Section Area: 1.06 sq.m.

Wetted Perimeter: 3.76 m

Hydraulic Radius: 0.28 m

Velocity: 0.47 m/s

Based on water depth

Velocity: 0.47 m/s

Using Manning's Formula:

## **APPENDIX D**

### **PRE-CONSULTATION MEETING NOTES & CITY OF OTTAWA SERVICING STUDY CHECKLIST**



# Site Plan Pre-consultation

Meeting Date: December 17, 2020

2167 McGee Side Road

---

**Applicant:** Paul Robinson  
P H Robinson Consulting

**Owner:** 11840398 Canada Inc.  
Attn: Christopher Simon

**Ward** 5—West Carleton

**Councillor** Eli El-Chantiry

**Proposal Summary:** Construct a 599 square metre industrial building containing office and warehouse space

**Attendees:** Paul Robinson, P H Robinson Consulting  
Tessa Di Iorio, Hydrogeologist, PIEDD, City of Ottawa  
Seana Turkington, Planner, PIEDD, City of Ottawa  
Erica Ogden, Environmental Planner, Mississippi Conservation Authority  
Sami Rehman, Environmental Planner, PIEDD, City of Ottawa (Regrets)  
Brian Morgan, Project Manager, PIEDD, City of Ottawa  
Mike Giampa, Senior Transportation Engineer, PIEDD, City of Ottawa

## Meeting Minutes

---

### Proposal details

- Proposed warehouse in an industrial subdivision
- Proposed 2-storey office and warehouse building (1 unit in warehouse may be leased to a commercial tenant)
- Site Plan only (no variances anticipated/ proposed at this point in time)
- Existing 12m drainage easement at rear of property
- Most of site is currently gravel
- There are no existing utilities on the site
- A sight triangle has been taken previously
- There is a 30cm reserve along John Cavanaugh Drive
- Existing well in front yard
- 2 potential stormwater management areas being considered
- 2 accesses to the site proposed (one off of McGee Side Road, another off of John Cavanaugh Drive)

### Planning Comments (Provided by Seana Turkington)

- Site connected via an existing access to 2171 McGee Side Road. Please discuss if this access will be removed as part of the required **Planning Rationale**.
- Please consider converting some of the site that is currently gravel to grass to assist with stormwater retention and to encourage additional soft landscaping as opposed to hardscape.
- Please plant trees to assist with the screening of the site as per policies in the Carp Road Corridor CDP.
- Please note that the draft version of the City's New Official plan was released in November 2020. Applicants are encouraged to review the draft Official Plan prior to formal application submission.
- There is currently a 30cm reserve on this property along the eastern property line. The applicant should examine its origins prior to submitting a formal application.
- If the additional access to John Cavanaugh Drive is not required, staff would suggest keeping one access off of McGee Side road.

#### Environmental Comments (Provided by Sami Rehman)

- It is suggested that the applicant plant as much vegetation (trees and shrubs) as possible on the south side of the watercourse that runs along the northwestern boundary of the property and along John Cavanaugh. Ideally, between the gravel edge of the parking lot and the slope of the watercourse.
- It is also recommended that as many trees as possible along the property line (shared with 2171 McGee Side Road) are retained.

#### Transportation Engineering Comments (Provided by Mike Giampa)

- A **Road Noise Study** is required for the office space.
- A TIA is not warranted but a **screening form** is still required.
- Verify that the sightlines at the McGee access are adequate for a 70km/h speed.

#### Engineering Comments (Provided by Brian Morgan)

- Exterior light fixtures must be indicated on plan and elevation drawings. All site plan applications require a **Site Plan Lighting Design**.
- Please identify and label the easements along the rear and from of the property, shown as parts 4 and 6 on plan 5R-12610.
- City records indicate the presence of a catch-basin or other drainage feature in the north-west corner of the lot. Please provide more information on this feature on your **Grading Plan**.
- Please detail how the two separate stormwater ponds will function in your **Stormwater Management Report**.
- The Stormwater management 'C' value must be calculated using the predevelopment value (trees/farmland to gravel).
- If the gravel access road at 2171 McGee Side Road is retained a **Joint Use Agreement** will be required.
- If any of these units will involve vehicle maintenance or repair floor drains will require an oil/grit separator, which must then outlet to a Legal and Sufficient outlet. An ECA approval from the MECP would also be required.
- The 30cm reserve along the eastern property line prevents access to John Cavanaugh Drive. You will need to apply to lift the reserve.
- Indicate the location(s) for temporary snow storage on the **Site Plan** and **Grading Plan**. These areas must not interfere with site drainage, septic system functionality, or traffic flow.
- Indicate fire routes on the **Site Plan**. This will require approval from Allan Evans in Fire Services.
- The **Geotechnical Report** and the **Hydrogeological Report** should identify if thin soils are present on this site.
- The City cannot accept the gravel as the pre-existing condition for Stormwater Management purposes.

#### Hydrogeology Comments (Provided by Tessa Di Iorio)

- Technical pre-consultation is highly recommended prior to initiating the field program and installing the well.
- The supply well needs to be established and fully tested for water quantity and water quality. This information must be assessed and provided in the **Hydrogeological Report**.
  - Water quantity- pump rate must be equal or greater than the maximum daily demand, and the demand must be justified in the report. Typically, the pump test length should mimic the working day (8 hours), but this can be discussed during the technical pre-consultation.
  - Water quality- test to confirm Ontario Drinking Water Standards, Objectives and Guidelines can be met.
- City of Ottawa mapping indicates that the site may be hydrogeologically sensitive due to thin soil cover on bedrock (i.e. less than 2m of soil over bedrock), which means the well may be at greater risk of contamination from sources at the surface. Soil thickness can be confirmed through an onsite test pit program.
  - If the site is hydrogeologically sensitive, then mitigative measures will be required to ensure the water supply is protected in the long term. Mitigative measures may include: increased separation distance between the well and septic system (and other sources of contamination); it is recommended that the well casing length be extended (at least doubles, i.e. 12m) to increase the lateral separation between the productive aquifer zone and the surface, placement of well and septic system should consider groundwater flow direction and natural soil thickness, and additional construction standards could be incorporated for the septic system (i.e. clay seal, advanced septic treatment).
- The **Hydrogeological Report** should also include a **Terrain Analysis and Septic System Impact Assessment** (as per MECP Guideline D-5-4 Section 5.6.3 – Predictive Assessment – Industrial/Commercial Developments). The result of the septic system impact assessment will identify a maximum allowable flow which should be compared to the proposed flow to confirm that impact is acceptable.
  - It is understood that the proposed septic flow is likely less than 10,000L/day. Please note that if flow is greater than 10,000L/day, then an ECA will be required from the MECP.
  - It is also understood that the majority of the site is currently compact gravel which does not allow water to infiltrate, this may be an issue in terms of providing sufficient infiltration to dilute the septic effluent and meeting dilution targets. At the pre-consultation meeting, it was discussed that part of the gravel area may be revegetated (or naturalized), this would help provide more infiltration on the site.

- The **Hydrogeological Report** should also discuss potential sources of contamination and how the well will be protected in the long term (i.e. snow storage, septic, stormwater, etc.). If the well is located in an area where it can be accessed by a car, snowplow or landscaping vehicle, then bollards are recommended to protect the well structure from damage.
- The **Grading Plan** should show how the grading around the well meets the requirements of the Wells Regulation, this can be shown with grades or clearly indicated in the notes section of the plan. To summarize, the casing must be a minimum of 0.4m above ground (after grade changes, if any), and the ground must slope away from the well to prevent water pooling around the well casing (minimum of 3 meters around the well).
- It was identified by the consultant at the pre-consultation meeting that the site is part of a previously approved industrial subdivision. If this is the case then if possible, the original **Hydrogeological Report** prepared to support the subdivision should be reviewed to confirm if there are any recommendations related to well or septic construction. However, it is understood that the subdivision approval was many years ago and if the report cannot be located, then the proposal will be assessed based on current standards without reviewing the previous report. Staff at the City can be contacted to review City records for the previous report.

Comments provided by MVCA (Provided by Erica Ogden)

- The subject property is not regulated by MVCA under Ontario Regulation 153/06.
- MVCA will review the proposed **Stormwater Management Plan** for the development.
  - The Carp River Watershed Subwatershed Study identified the property as a moderate groundwater recharge area which has an annual infiltration target of 104mm/year.
  - The water quality requirement for the Carp River is a normal level of protection which requires 70% total suspended solids removal.
- Maintaining vegetation along the drainage easement is recommended.

## ADDITIONAL COMMENTS

### Planning Comments

**Official Plan:** Rural Employment Area

**Secondary Plan and/or Community Design Plan:** Carp Road Corridor

**Zoning By-law:** Rural General Industrial Zone Subzone 5 (RG5)

1. Parking:  
All parking must comply with Part 4 (Sections 100-114) of the Zoning By-law.
2. Garbage Enclosure:  
Any outdoor refuse collection areas must comply with Section 110(3) of the Zoning By-law.

### Transportation Comments:

- Please submit a TIA screening form prior to submission of a formal application.

### Engineering and Hydrogeology Comments:

#### Water and Sanitary:

- No municipal services are adjacent/near the proposed development and the site will be serviced with an on-site well and septic system.
- The **Septic Permit** should be provided as part of the application.
- A **Groundwater Impact Study** and an **Environmental Compliance Agreement (ECA)** will be required for sewage design flows exceeding 10,000 L/day.
- An oil and grit separator should be used where vehicles are maintained, cleaned, or potential for discharge of contaminants.

#### Fire Protection:

- The applicant should have their consultant contact Ottawa Fire Services to determine if fire protection is required.  
Contact Information:  
Allan Evans

Engineer, Fire Protection  
City of Ottawa  
613-580-2424 x24119  
[Allan.Evans@ottawa.ca](mailto:Allan.Evans@ottawa.ca)

Storm Water Management:

- Overland flows should be directed to the roadside ditch.
- Water quality design requirements will be determined by the Mississippi Valley Conservation Authority.
- All stormwater management determinations shall have supporting rationale.
- If an oil and grit is provided the discharge of the wastewater shall be directed towards the roadside ditch.

Easement:

- The applicant shall identify all easements on site and provide the legal easement agreement as part of their submission.

Snow Storage:

- Any portion of the subject property which is intended to be used for permanent or temporary snow storage shall be as shown on the site plan and grading plan. Snow storage shall not interfere with grading and drainage patterns. Snow storage areas shall be setback from the property lines, foundations, fencing or landscaping a minimum of 1.5m. Snow storage areas shall not occupy driveways, aisles, required parking spaces or any portion of a road allowance.

Permits and Approvals:

- Please contact the Ministry of the Environment, Conservation, and Parks (MECP) and Mississippi Valley Conservation Authority (MVCA), amongst other federal and provincial departments/agencies, to identify all the necessary permits and approvals required to facilitate the development: responsibility rests with the developer and their consultant for obtaining all external agency approvals. The address shall be in good standing with all approval agencies. Copies of confirmation of correspondence will be required by the City of Ottawa from all approval agencies that a form of assent is given. No construction shall commence until after a commence work notification is given.

Ministry of the Environment, Conservation, and Parks

Mississippi Valley Conservation Authority

Contact Information:

[moeccottawasewage@ontario.ca](mailto:moeccottawasewage@ontario.ca)

Contact Information:

Erica Ogden, Environmental Planner

[eogden@mvc.on.ca](mailto:eogden@mvc.on.ca)

Environmental Compliance Agreement:

An **Environmental Compliance Agreement** (ECA) shall be obtained by the MECP for the proposed sewage works under the Ontario Resources Act if required. Typically, approval timelines for direct submission to the MECP are between 9 – 11 months.

**Site Plan Control Engineering Reports:**

- Geotechnical Report
  - The geotechnical report shall adequately discuss the fill requirements, grade raise restrictions, and other limitations and earthworks required for development within a floodplain or adjacent to a watercourse, and wetland.
  - Atterberg limits, consolidation testing, shear strength testing, grade raise restriction, sieve analysis, and discussion thereof, amongst other data, will be required in if sensitive marine clay, or similar conditions are found.
  - The geotechnical consultant will need to provide full copies of any published and peer reviewed papers relied on to determine results and conclusions.
- Hydrogeology and Terrain Analysis

- The hydrogeology report should follow the recommendations prescribed in the subdivision hydrogeology and terrain analysis if determined to be part of the industrial subdivision. “Hydrogeological Investigation and Terrain Evaluation, Propose Rural Industrial Subdivision”, prepared by Golder Associates Ltd, dated Mar 1994, project no. 931-2820.
- The hydrogeology analysis should provide a pump test duration in accordance to MECP requirements. All calculations shall be clearly provided.
- The report shall demonstrate the quality of drinking water and provide a water sample test. The report should clearly discuss the treatment methods to achieve acceptable water quality to MECP standards.
- The terrain analysis shall clearly demonstrate the suitability of the soils to adequately support a septic system at this location and the capacity of dilution. Based on superficial geological maps thin soils may be present on the property.
- Servicing Report
- Stormwater Management Report

**Site Plan Control Engineering Plans:**

- Grading and Drainage Plan
- Servicing Plan
- Sediment and Erosion Control Plan
  - The Erosion and Sediment Control Plan should manage all loose material from being transported into adjacent properties and waterways. The Conservation Authority should be consulted to determine any additional measures that may be required.

To request City of Ottawa plan(s) or report information please contact the City of Ottawa Information Centre:

[InformationCentre@ottawa.ca](mailto:InformationCentre@ottawa.ca) <<mailto:InformationCentre@ottawa.ca>> OR (613) 580-2424 ext. 44455

As per section 53 of the Professional Engineers Act, O. Reg 941/40, R.S.O. 1990, all documents prepared by engineers must be signed and dated on the seal.

Application Submission Information

Application Type: **Site Plan Control-Rural, Standard**

For information on Zoning By-law Amendment Applications and Site Plan Control Applications, including fees, please visit: <https://ottawa.ca/en/city-hall/planning-and-development/information-developers/development-application-review-process/development-application-submission/fees-and-funding-programs/development-application-fees>

The application processing timeline generally depends on the quality of the submission. For more information on standard processing timelines, please visit: <https://ottawa.ca/en/city-hall/planning-and-development/information-developers/development-application-review-process/development-application-submission/development-application-forms#site-plan-control>

Prior to submitting a formal application, it is recommended that you pre-consult with the Ward Councillor.

Application Submission Requirements

For information on the preparation of Studies and Plans and the City’s requirements, please visit: <https://ottawa.ca/en/city-hall/planning-and-development/information-developers/development-application-review-process/development-application-submission/guide-preparing-studies-and-plans>

**Please provide electronic copy (PDF) of all plans and studies required.**

**All plans and drawings must be produced on A1-sized paper and folded to 21.6 cm x 27.9 cm (8½“x 11”).**

**Note that many of the plans and studies collected with this application must be signed, sealed and dated by a qualified engineer, architect, surveyor, planner or designated specialist.**



Douglas Gray <d.gray@dbgrayengineering.com>

---

**RE: 2167 McGee Side Road**

1 message

---

**Whittaker, Damien** <Damien.Whittaker@ottawa.ca>

Mon, Jul 19, 2021 at 3:14 PM

To: Douglas Gray <d.gray@dbgrayengineering.com>

Cc: Chris Vaughan <chris@mbford.ca>, "L5 Impact Design & Management Inc. (Steve Lajeunesse)" <steve@l5impact.com>, Paul Robinson <probinson@probinsonconsulting.com>, Ryan Faith <r.fait@dbgrayengineering.com>, "Morgan, Brian" <Brian.Morgan@ottawa.ca>

Hello Doug,

I am open to your clarification of issues improved from my limited experience with it, however Brian is away and I suggest that the file would not like to wait his absence.

I see from the pre-consultation meeting minutes attached that the quantity criteria was not recorded. I see from the 1<sup>st</sup> submission and 2<sup>nd</sup> submission comments that Brian, on both occasions had mentioned the quantity criteria.

I disagree with the statement below that the City "will now require" the post-development to pre-development; I suggest it is standard, based on the criteria at the location. My memory is that I had made it clear, a number of times, the following- that 8.3.6.1 allows post-development to pre-development in rural areas. It is not explicitly stated, however it is applied, as Brian stated, for those lots that are in a truly rural situation, with no other development nearby. However, the Sewer Design Guidelines, Second Edition, Document SDG002, October 2012, City of Ottawa (Guidelines) including technical bulletins, states where there is an existing sewer (reminder that a sewer is referred to in Appendix 1 as a conduit, open channel, ditch watercourse or pipe) and it is an existing area and it is a commercial application that 100-year post-development must be controlled to the 2-year, or 5-year, (usually 5-year) pre-development rate. The 100-year post-development to 100-year pre-development together with 5-year post-development to 5-year pre-development is the exception that has been used often in the past; now that subsequent development is occurring it is anticipated that development, in the rural area, will shift to the 100-year post-development must be controlled to the 2-year or 5-year (usually 5-year) pre-development rate style of SWM.

The examples referred to, without addresses, are noted, but do not appear to be established as a form of precedent, and they are not precedent.

The concern with comment 12 is that the coefficient used by the consultant appears to take the grass as 0.3 when it should be taken as 0.2 for a 5-year event as taken by consultants from a synthesis of the information in Table 5.7 (section 5.4.5.2.1).

I will assume, for comment 13, that the drawings referred to as C-5 and C-6 are satisfactory to respond to the City comment, but I will leave that review for Brian to confirm.

Please feel free to ask for clarification, or further information, on any of the comments above.

Thank you,

Damien Whittaker, P.Eng

Senior Engineer - Infrastructure Applications | Ingénieur principal - applications d'infrastructure

Development Review, Rural Services Unit | Examen des projets d'aménagement, Unité des services ruraux

Planning, Infrastructure and Economic Development Department | Services de la planification, de l'infrastructure et du développement économique

City of Ottawa | ville d'Ottawa ▪ 🏢 110 Laurier Avenue West | 110, avenue, Laurier ouest, Ottawa, Ontario K1P 1J1, Ontario

[damien.whittaker@ottawa.ca](mailto:damien.whittaker@ottawa.ca) ▪ 📞 01-14

\*\*\* Please note that I will be on vacation on the following dates \*\*\*

August 9, 10, 11, 12, 13, 16, 17, 18, 19, 20

---

**From:** Douglas Gray <[d.gray@dbgrayengineering.com](mailto:d.gray@dbgrayengineering.com)>

**Sent:** July 19, 2021 10:26 AM

**To:** Morgan, Brian <[Brian.Morgan@ottawa.ca](mailto:Brian.Morgan@ottawa.ca)>

**Cc:** Whittaker, Damien <[Damien.Whittaker@ottawa.ca](mailto:Damien.Whittaker@ottawa.ca)>; Chris Vaughan <[chris@mbford.ca](mailto:chris@mbford.ca)>; L5 Impact Design & Management Inc. (Steve Lajeunesse <[steve@l5impact.com](mailto:steve@l5impact.com)>; Paul Robinson <[probinson@probinsonconsulting.com](mailto:probinson@probinsonconsulting.com)>; Ryan Faith <[r.fairh@dbgrayengineering.com](mailto:r.fairh@dbgrayengineering.com)>

**Subject:** 2167 McGee Side Road

**CAUTION: This email originated from an External Sender. Please do not click links or open attachments unless you recognize the source.**

**ATTENTION : Ce courriel provient d'un expéditeur externe. Ne cliquez sur aucun lien et n'ouvrez pas de pièce jointe, excepté si vous connaissez l'expéditeur.**

Hi Brian

With reference to the attached Comments, Item 11 states: *"The Stormwater requirements for this site requires a SWM Design using the 100-year post to 5-year pre design criteria. Reference sections 8.3.6 and 8.3.7.3 of the 'Ottawa Design Guidelines (Sewer) 2012'. This holds true for the urban, suburban, and rural areas. An allowance can be made in the rural area if the proposed site is on a truly rural, isolated lot, with no other development within a reasonable distance. As this site is within a fairly developed area, we can confirm that the stormwater requirement for this site will be 100-year post to 5-year pre. This has been confirmed with the department's Senior Engineer."*

After the discussions and exchange of emails after the [2026 Carp Rd](#) pre-consult meeting last month I understand that the City will now require that we design the SWM to 100-year post to 5-year pre in some rural projects. This is in spite of the fact we have worked on about a dozen or so projects along Carp Rd and adjacent properties none are 100-yr post to 5-year pre. We have worked on a few dozen more in similar areas in the City where there are no storm sewers and none of those projects are designed 100-yr post to 5-year pre. All projects we have worked on, where there are

no storm sewers, the SWM requirements are the 100-yr post to pre and the 5-year post to pre. Regardless, I understand that the City has changed their policy.

However, with this project, this new requirement directly contradicts the information you provided in the December 17, 2020 pre-consult meeting, in which you stated that we are to design Pre=Post, 100-year post to 100-year pre and 5-year post to 5-year pre. For the City to change the criteria we are to follow at this late stage of the approval process is not reasonable as it will require a significant amount of time to revise and may have a significant effect on the site plan. Please reconsider.

The last sentence of comment 12 states: *"Please note that the C values for the areas covered by gravel cannot be used in the pre-development calculations."* On page 4 of our report we state; *"However, although 70% of the area is covered with granular material and has been that way for over 20 years, the City requires that the pre-development conditions be the conditions that existed prior to the placement of the granular material (sometime in the 1990s), which was a grassed field. It is calculated that this pre-development condition reflects a 5-year runoff coefficient of 0.30 and 0.375 for the 100-year."* 7. Refer to conclusion 7 on page 5: *"The post development release rate for the 5 and 100-year storm events are controlled to be equal to or less than the flow produced by the pre-development conditions. Although 70% of the area is covered with compacted granular material and has been that way for over 20 years, the City requires that the pre-development conditions be considered to be a grassed field. The maximum post-development release rate for both the 100-year and 5-year storm event is calculated to be equal to the maximum allowable; and 48% lower than the existing conditions."* Also refer to the Summary on page 9 and calculation on pages 10 and 13. Is this comment a result of an oversight or are there any issues with our report and design?

Comment 13 states: *"Please include two plans indicating the pre-development and post-development runoff zones and coefficients."* These were already included on drawings C-5 and C-6. Again, is this an oversight or is there an issue?

Regards, Doug

Stormwater Management - Grading & Drainage - Storm & Sanitary Sewers - Watermains

700 Long Point Circle

Tel: 613-425-8044

Ottawa, Ontario K1T 4E9

[d.gray@dbgrayengineering.com](mailto:d.gray@dbgrayengineering.com)

This e-mail originates from the City of Ottawa e-mail system. Any distribution, use or copying of this e-mail or the information it contains by other than the intended recipient(s) is unauthorized. Thank you.

Le présent courriel a été expédié par le système de courriels de la Ville d'Ottawa. Toute distribution, utilisation ou reproduction du courriel ou des renseignements qui s'y trouvent par une personne autre que son destinataire prévu est interdite. Je vous remercie de votre collaboration.

**3 attachments**





**2167 McGee Side Road\_ Meeting Minutes.pdf**  
200K



**2167 McGee Side Road-1st Submission Comments.doc**  
301K



**2167 McGee Side Road - 2nd Submission Comments.docx**  
106K

## **GENERAL**

Executive Summary: **N/A**

Date and revision number of report: **Included**

Location map and plan showing municipal address, boundary and layout of proposed development: **Included**

Plan showing site and location of all existing services: **Included**

Development statistics, land use, density, adherence to zoning and Official Plan and reference to applicable watershed and subwatershed plans: **N/A**

Summary of Pre-Application Consultation meetings with City of Ottawa and other approval agencies: **Included**

Confirmation of conformance with higher level studies: **N/A**

Statement of objectives and servicing criteria: **Included**

Identification of existing and proposed infrastructure available in the immediate area: **Included**

Identification of Environmentally Significant Areas, watercourses and Municipal Drains potentially impacted by the proposed development: **N/A**

Concept level master grading plan to confirm existing and proposed grades in the proposed development: **Included**

Identification of potential impacts of proposed piped services on private services on adjacent lands: **N/A**

Proposed phasing of proposed development: **N/A**

Reference to geotechnical studies: **Included**

All preliminary and formal site plan submissions should have the following information:

Metric scale: **Included**

North arrow: **Included**

Key plan: **Included**

Property limits: **Included**

Existing and proposed structures and parking areas: **Included**

Easements, road widenings and right-of-ways: **Included**

Street names: **Included**

## **WATER SERVICING**

Confirmation of conformance with Master Servicing Study: **N/A**

Availability of public infrastructure to service proposed development: **Included**

Identification of system constraints: **Included**

Identification of boundary conditions: **Included**

Confirmation of adequate domestic supply: **Included**

Confirmation of adequate fire flow: **Included**

Check of high pressures: **Included**

Definition of phasing constraints: **N/A**

Address reliability requirements: **N/A**

Check on necessity of a pressure zone boundary modification: **N/A**

Reference to water supply analysis to show that major infrastructure is capable of delivering sufficient water for proposed development: **Included**

Description of proposed water distribution network: **Included**

Description of required off-site infrastructure to service proposed development: **N/A**

Confirmation that water demands are calculated based on the City of Ottawa Water Design Guidelines: **Included**

Provision of a model schematic showing the boundary conditions locations, streets, parcels and building locations: **Included**

## **SANITARY SERVICING**

Summary of proposed design criteria: **Included**

Confirmation of conformance with Master Servicing Study: **N/A**

Consideration of local conditions that may contribute to extraneous flows that are higher than the recommended flows in the City of Ottawa Sewer Design Guidelines: **N/A**

Description of existing sanitary sewer available for discharge of wastewater from proposed development: **Included**

Verification of available capacity in downstream sanitary sewer and/or identification of upgrades necessary to service proposed development: **N/A**

Calculations related to dry-weather and wet-weather flow rates: **Included**

Description of proposed sewer network: **Included**

Discussion of previously identified environmental constraints and impact on servicing: **N/A**

Impacts of proposed development on existing pumping stations or requirements for new pumping station: **N/A**

Forcemain capacity in terms of operational redundancy, surge pressure and maximum flow velocity: **N/A**

Identification and implementation of emergency overflow from sanitary pumping stations in relation to the hydraulic grade line to protect against basement flooding: **N/A**

Special considerations (e.g. contamination, corrosive environment): **N/A**

## **STORMWATER MANAGEMENT & STORM SERVICING**

Description of drainage outlets and downstream constraints: **Included**

Analysis of available capacity in existing public infrastructure: **N/A**

Plan showing subject lands, its surroundings, receiving watercourse, existing drainage pattern and proposed drainage pattern: **Included**

Water quantity control objective: **Included**

Water quality control objective: **Included**

Description of the stormwater management concept: **Included**

Setback from private sewage disposal systems: **N/A**

Watercourse and hazard lands setbacks: **N/A**

Record of pre-consultation with the Ministry of the Environment, Conservation and Parks and the Conservation Authority having jurisdiction on the affected watershed: **N/A**

Confirmation of conformance with Master Servicing Study: **N/A**

Storage requirements and conveyance capacity for minor events (5-year return period) and major events (100-year return period): **Included**

Identification of watercourses within the proposed development and how watercourses will be protected or if necessary altered by the proposed development: **N/A**

Calculation of pre-development and post-development peak flow rates: **Included**

Any proposed diversion of drainage catchment areas from one outlet to another: **N/A**

Proposed minor and major systems: **Included**

If quantity control is not proposed, demonstration that downstream system has adequate capacity for the post-development flows up to and including the 100-year return period storm event: **N/A**

Identification of potential impacts to receiving watercourses: **N/A**

Identification of municipal drains: **N/A**

Description of how the conveyance and storage capacity will be achieved for the proposed development: **Included**

100-year flood levels and major flow routing: **Included**

Inclusion of hydraulic analysis including hydraulic grade line elevations: **N/A**

Description of erosion and sediment control during construction: **Included**

Obtain relevant floodplain information from Conservation Authority: **N/A**

Identification of fill constraints related to floodplain and geotechnical investigation: **N/A**

## **APPROVAL AND PERMIT REQUIREMENTS**

Conservation Authority as the designated approval agency for modification of floodplain, potential impact on fish habitat, proposed works in or adjacent to a watercourse, cut/fill permits and Approval under Lakes and Rivers Improvement Act. The Conservation Authority is not the approval authority for the Lakes and Rivers Improvement Act. Where there are Conservation Authority regulations in place, approval under the Lakes and Rivers Improvement Act is not required, except in cases of dams as defined in the Act: **N/A**

Application for Certificate of Approval (CofA) under the Ontario Water Resources Act: **N/A**

Changes to Municipal Drains: **N/A**

Other permits (e.g. National Capital Commission, Parks Canada, Public Works and Government Services Canada, Ministry of Transportation): **N/A**

## **CONCLUSIONS**

Clearly stated conclusions and recommendations: **Included**

Comments received from review agencies: **N/A**

Signed and stamped by a professional Engineer registered in Ontario: **Included**